

# PCM5252 Purepath™ 智能放大器 4.2V<sub>RMS</sub> DirectPath™、114dB 音频立体声差分输出 DAC

## 1 特性

- 差分 DirectPath™ 接地偏置输出
- 智能放大器技术
- 市场领先的低带外噪声
- 可选数字滤波器延迟与性能
- 无需隔离直流电流的电容器
- 集成的负电荷泵
- 智能静音系统：软斜升或斜降搭配模拟静音，实现 120dB 静音信噪比 (SNR)
- 具有 BCK 基准的集成高性能音频锁相环 (PLL)，可在内部生成 SCK
- 接收 16 位、24 位和 32 位音频数据
- PCM 数据样式：I<sup>2</sup>S，左对齐
- 通用串行接口 (SPI) 或者 I<sup>2</sup>C 控制
- 硬件配置
- 当 LRCK 和 BCK 被置为无效时，自动进入省电模式
- 1.8V 或 3.3V 故障安全低电压互补金属氧化物半导体 (LVCMOS) 数字输入
- 单电源运算：
  - 3.3V 模拟电源、1.8V 或 3.3V 数字电源
- 集成型加电复位
- 小型 32-pin VQFN 封装

## 2 应用

- HiFi 智能手机
- A/V 接收器
- DVD, BD 播放器
- HDTV 接收器

## 3 说明

PCM5252 是一款单片互补金属氧化物半导体 (CMOS) 集成电路，由立体声数模转换器 (DAC) 和采用薄型小外形尺寸 (TSSOP) 封装的附加支持电路组成。

PCM5252 使用 TI 最新一代高级分段 DAC 架构产品，可实现出色的动态性能并提升针对时钟抖动的耐受度。

PCM5252 集成了一个完全可编程的 miniDSP 内核，允许开发人员将滤波器、动态范围控件、定制插值器等各类功能集成到相关产品中。

PCM5252 集成了德州仪器 (TI) PurePath™ 智能放大器技术的 ROM 组件，可更多地以峰值功率（而非平均额定功率）驱动扬声器，同时不必担心扬声器因音圈偏移或热过载而受损。

PCM5252 提供 4.2 V<sub>RMS</sub> 中央接地差分输出（设计人员无需在输出端连接隔直电容）以及传统意义上与单电源线路驱动器相关的外部静音电路。”

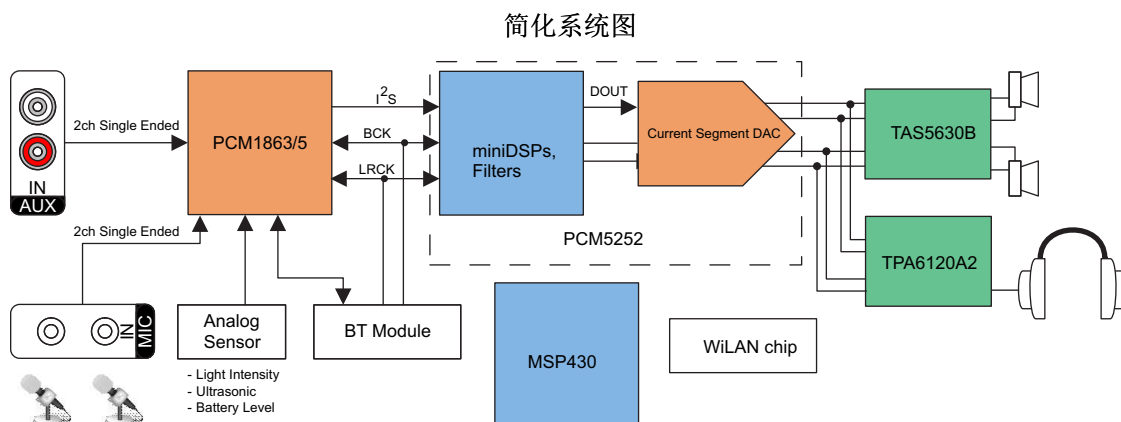
器件上集成的 PLL 免除了对于系统时钟（通常称为主时钟）的需要，从而实现一个 3 线制 I<sup>2</sup>C 连接并减少了系统电磁干扰 (EMI)。

相关框图请参见 [Functional Block Diagram](#)。

器件信息(1)

部件名称	封装	封装尺寸 (标称值)
PCM5252	VQFN (32)	5.00mm x 5.00mm

(1) 要了解所有可用封装，请参见数据表末尾的可订购产品附录。



## 目录

1	特性 .....	1	8.4	Device Functional Modes .....	48
2	应用 .....	1	<b>9</b>	<b>Application and Implementation .....</b>	<b>54</b>
3	说明 .....	1	9.1	Application Information .....	54
4	修订历史记录 .....	2	9.2	Typical Application .....	54
5	<b>Device Comparison .....</b>	<b>3</b>	<b>10</b>	<b>Power Supply Recommendations .....</b>	<b>56</b>
6	<b>Pin Configuration and Functions .....</b>	<b>4</b>	10.1	Power Supply Distribution and Requirements .....	56
6.1	Control Mode Effect On Pin Assignments .....	4	10.2	Recommended Powerdown Sequence .....	57
6.2	Pin Assignments .....	4	10.3	External Power Sense Undervoltage Protection Mode .....	60
7	<b>Specifications .....</b>	<b>7</b>	10.4	Power-On Reset Function .....	62
7.1	Absolute Maximum Ratings .....	7	10.5	PCM5252 Power Modes .....	63
7.2	ESD Ratings .....	7	<b>11</b>	<b>Layout .....</b>	<b>65</b>
7.3	Recommended Operating Conditions .....	7	11.1	Layout Guidelines .....	65
7.4	Thermal Information .....	7	11.2	Layout Example .....	65
7.5	Electrical Characteristics .....	8	<b>12</b>	<b>Programming .....</b>	<b>66</b>
7.6	Switching Characteristics .....	11	12.1	Coefficient Data Formats .....	66
7.7	Timing Requirements: SCK Input .....	11	12.2	Power Down and Reset Behavior .....	66
7.8	Timing Requirements: PCM Audio Data .....	12	<b>13</b>	<b>Register Maps .....</b>	<b>67</b>
7.9	Timing Requirements: I <sup>2</sup> S Master, See <a href="#">Figure 6</a> ...	12	13.1	PCM5252 Register Map .....	67
7.10	Timing Requirements: XSMT .....	13	<b>14</b>	<b>器件和文档支持 .....</b>	<b>115</b>
7.11	Typical Characteristics .....	14	14.1	社区资源 .....	115
<b>8</b>	<b>Detailed Description .....</b>	<b>16</b>	14.2	商标 .....	115
8.1	Overview .....	16	14.3	静电放电警告 .....	115
8.2	Functional Block Diagram .....	17	<b>15</b>	<b>机械、封装和可订购信息 .....</b>	<b>115</b>
8.3	Feature Description .....	17			

## 4 修订历史记录

注：之前版本的页码可能与当前版本有所不同。

日期	修订版本	注释
2014 年 11 月	*	最初发布。

## 5 Device Comparison

**Table 1. Typical Performance (3.3-V Power Supply)**

PARAMETER	PCM5252
SNR	114 dB
Dynamic range	114 dB
THD+N at -1 dBFS	-93 dB
Full-scale single-ended output	4.2 V <sub>RMS</sub> (GND center)
Normal 8x oversampling digital filter latency	20/fS
Low latency 8x oversampling digital filter latency	3.5/fS
Sampling frequency	8 kHz to 384 kHz
System clock multiples (f <sub>SCK</sub> ): 64, 128, 192, 256, 384, 512, 768, 1024, 1152, 1536, 2048, 3072	Up to 50 MHz

## 6 Pin Configuration and Functions

### 6.1 Control Mode Effect On Pin Assignments

The PCM5252 supports control from I<sup>2</sup>C, SPI and Hardware Modes (referred to as HW mode). Selection of modes is done using MODE1 and MODE2 pins. (See the *PCM5252 Pin Functions* table.

SPI Mode is selected by pulling MODE1 to DVDD.

I<sup>2</sup>C Mode is selected by pulling MODE1 to DGND and MODE2 to DVDD.

Hardware Control Mode is selected by pulling both MODE1 and MODE2 pins to DGND.

### 6.2 Pin Assignments

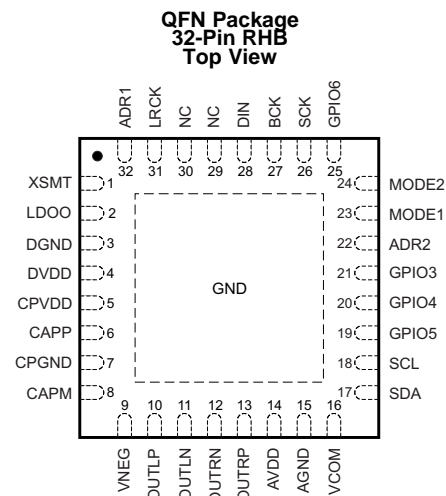


Figure 1. I<sup>2</sup>C Control

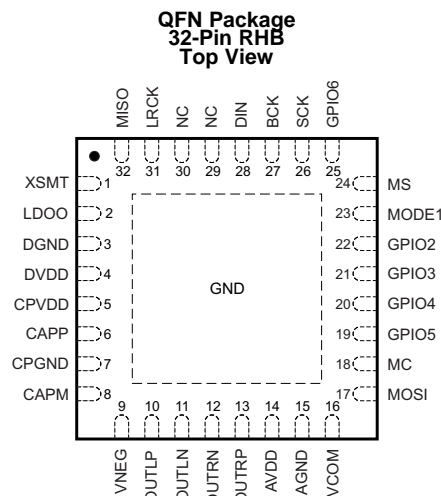


Figure 2. SPI Control

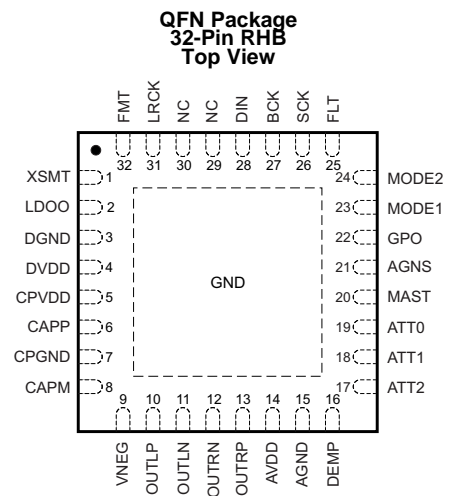


Figure 3. Hardware Control

### PCM5252 Pin Functions

PIN			I/O	DESCRIPTION
MODE, NAME		PIN		
I <sup>2</sup> C	SPI			
	XSMT	1	I	Soft mute control <sup>(1)</sup> Soft mute (Low) / soft un-mute (High)
	LDOO	2	-	Internal logic supply rail pin for decoupling, 1.8V
	DGND	3	-	Digital ground
	DVDD	4	-	Digital power supply, 3.3V or 1.8V
	CPVDD	5	-	Charge pump power supply, 3.3V
	CAPP	6	O	Charge pump flying capacitor pin for positive rail
	CPGND	7	-	Charge pump ground
	CAPM	8	O	Charge pump flying capacitor pin for negative rail
	VNEG	9	O	Negative charge pump rail pin for decoupling, -3.3V
	OUTLP	10		Positive Differential Analog output from DAC left channel
	OUTLN	11		Negative Differential Analog output from DAC left channel
	OUTRN	12		Negative Differential Analog output from DAC right channel
	OUTRP	13		Positive Differential Analog output from DAC right channel.
	AVDD	14	-	Analog power supply, 3.3V
	AGND	15	-	Analog ground
	VCOM	16	O	VCOM output (Optional mode selected by register; default setting is VREF mode.) When in VREF mode (default), this pin ties to GND. When in VCOM mode, decoupling capacitor to GND is required.
	DEMP		I	HW

(1) Failsafe LVCMOS Schmitt trigger input.

**Pin Assignments (continued)**
**PCM5252 Pin Functions (continued)**

PIN			PIN	I/O	DESCRIPTION
MODE, NAME					
I <sup>2</sup> C	SPI	HW			
SDA	MOSI	ATT2	17	I/O	I <sup>2</sup> C Data for I <sup>2</sup> C <sup>(2)(1)</sup>
				I	SPI Input data for SPI <sup>(1)</sup>
					HW Digital gain and attenuation control pin
SCL	MC	ATT1	18	I	I <sup>2</sup> C Input clock for I <sup>2</sup> C <sup>(1)</sup>
					SPI Input clock for SPI <sup>(1)</sup>
					HW Digital gain and attenuation control pin
GPIO5		ATT0	19	I/O	I <sup>2</sup> C, SPI General purpose digital input and output port <sup>(3)</sup>
					HW Digital gain and attenuation control pin
GPIO4		MAST	20	I/O	I <sup>2</sup> C, SPI General purpose digital input and output port <sup>(3)</sup>
					HW I <sup>2</sup> S Master clock select pin : Master (High) BCK/LRCK outputs, Slave (Low) BCK/LRCK inputs
GPIO3		AGNS	21	I/O	I <sup>2</sup> C, SPI General purpose digital input and output port <sup>(3)</sup>
					HW Analog gain selector : 0dB 2V <sub>RMS</sub> output (Low), -6dB 1V <sub>RMS</sub> output (High)
ADR2	GPIO2	GPO	22	I/O	I <sup>2</sup> C 2nd LSB address select bit for I <sup>2</sup> C <sup>(3)</sup>
					SPI General purpose digital input and output port <sup>(3)</sup>
				O	HW General Purpose Output (Low level)
MODE1			23	I	Mode control selection pin <sup>(1)</sup> MODE1 = Low, MODE2 = Low : <b>Hardwired</b> mode Reserved MODE1 = Low, MODE2 = High: <b>I<sup>2</sup>C</b> mode MODE1 = High: <b>SPI</b> mode
MODE2	MS	MODE2			I/O
		FLT	25	I/O	I <sup>2</sup> C, SPI General purpose digital input and output port
					I
SCK			26	I	System clock input <sup>(1)</sup>
BCK			27	I/O	Audio data bit clock input (slave) or output (master) <sup>(1)</sup>
DIN			28	I	Audio data input <sup>(1)</sup>
NC			29	-	No connect
			30	-	
LRCK			31	I/O	Audio data word clock input (slave) or output (master) <sup>(1)</sup>
ADR1	MISO (GPIO1)	FMT	32	I/O	I <sup>2</sup> C LSB address select bit for I <sup>2</sup> C
					SPI Primary output data for SPI readback. Secondary; general purpose digital input/output port controlled by register
					HW Audio format selection : I <sup>2</sup> S (Low) / Left justified (High)

(2) Open-drain configuration in out mode.

(3) Internal Pulldown

**Table 2. Gain and Attenuation in Hardwired Mode**

<b>ATT PIN CONDITION (ATT2 : ATT1 : ATT0)</b>	<b>GAIN AND ATTENUATION LEVEL</b>
( 0 0 0 )	0 dB
( 0 0 1 )	+ 3 dB
( 0 1 0 )	+ 6 dB
( 0 1 1 )	+ 9 dB
( 1 0 0 )	+ 12 dB
( 1 0 1 )	+ 15 dB
( 1 1 0 )	- 6 dB
( 1 1 1 )	- 3 dB

## 7 Specifications

### 7.1 Absolute Maximum Ratings

over operating free-air temperature range (unless otherwise noted)

		MIN	MAX	UNIT
Supply voltage	AVDD, CPVDD, DVDD	-0.3	3.9	V
	LDO with DVDD at 1.8 V	-0.3	2.25	
Digital input voltage	DVDD at 1.8 V	-0.3	2.25	V
	DVDD at 3.3 V	-0.3	3.9	
Analog input voltage		-0.3	3.9	V
Storage temperature, T <sub>stg</sub>		-40	125	°C

### 7.2 ESD Ratings

			VALUE	UNIT
V <sub>(ESD)</sub>	Electrostatic discharge	Human-body model (HBM), per ANSI/ESDA/JEDEC JS-001 <sup>(1)</sup>	±2500	V
		Charged-device model (CDM), per JEDEC specification JESD22-C101 <sup>(2)</sup>	±1500	

(1) JEDEC document JEP155 states that 500-V HBM allows safe manufacturing with a standard ESD control process.

(2) JEDEC document JEP157 states that 250-V CDM allows safe manufacturing with a standard ESD control process.

### 7.3 Recommended Operating Conditions

				MIN	NOM	MAX	UNIT
A <sub>VDD</sub>	Analog power supply voltage	Referenced to AGND <sup>(1)</sup>	VCOM mode	3	3.3	3.46	V
			VREF mode	3.2	3.3	3.46	
D <sub>VDD</sub>	Digital power supply voltage	Referenced to DGND <sup>(1)</sup>	1.8 V DVDD	1.65	1.8	1.95	V
			3.3 V DVDD	3.1	3.3	3.46	
CPVDD	Charge pump supply voltage	Referenced to CPGND <sup>(1)</sup>		3.1	3.3	3.46	V
MCLK	Master clock frequency					50	MHz
LOL, LOR	Stereo line output load resistance			2	10		kΩ
C <sub>LOUT</sub>	Digital output load capacitance				10		pF
T <sub>J</sub>	Operating junction temperature			-25		85	°C

(1) All grounds on board are tied together; they must not differ in voltage by more than 0.2-V maximum, for any combination of ground signals.

### 7.4 Thermal Information

THERMAL METRIC <sup>(1)</sup>			PW	UNIT
			20 PINS	
R <sub>θJA</sub>	Junction-to-ambient thermal resistance		91.2	°C/W
R <sub>θJC(top)</sub>	Junction-to-case (top) thermal resistance		25.3	°C/W
R <sub>θJB</sub>	Junction-to-board thermal resistance		42	°C/W
ψ <sub>JT</sub>	Junction-to-top characterization parameter		1	°C/W
ψ <sub>JB</sub>	Junction-to-board characterization parameter		41.5	°C/W
R <sub>θJC(bot)</sub>	Junction-to-case (bottom) thermal resistance		—	°C/W

(1) For more information about traditional and new thermal metrics, see the [Semiconductor and IC Package Thermal Metrics](#) application report.

## 7.5 Electrical Characteristics

All specifications at  $T_A = 25^\circ\text{C}$ ,  $AV_{DD} = CPV_{DD} = DV_{DD} = 3.3\text{V}$ ,  $f_S = 48\text{kHz}$ , system clock =  $512 f_S$  and 24-bit data unless otherwise noted.

PARAMETER	TEST CONDITIONS	MIN	TYP	MAX	UNIT
Resolution		16	24	32	Bits
<b>Digital Input/Output</b>					
<i>Logic family: 3.3 V LVCMOS compatible</i>					
$V_{IH}$	Input logic level, high	$0.7 \times DV_{DD}$			V
$V_{IL}$	Input logic level, low			$0.3 \times DV_{DD}$	V
$I_{IH}$	Input logic current, high	$V_{IN} = V_{DD}$		10	$\mu\text{A}$
$I_{IL}$	Input logic current, low	$V_{IN} = 0\text{ V}$		-10	$\mu\text{A}$
$V_{OH}$	Output logic level, high	$I_{OH} = -4\text{ mA}$	$0.8 \times DV_{DD}$		V
$V_{OL}$	Output logic level, low	$I_{OL} = 4\text{ mA}$	$0.22 \times DV_{DD}$		V
<i>Logic family 1.8 V LVCMOS compatible</i>					
$V_{IH}$	Input logic level, high	$0.7 \times DV_{DD}$			V
$V_{IL}$	Input logic level, low			$0.3 \times DV_{DD}$	V
$I_{IH}$	Input logic current, high	$V_{IN} = V_{DD}$		10	$\mu\text{A}$
$I_{IL}$	Input logic current, low	$V_{IN} = 0\text{ V}$		-10	$\mu\text{A}$
$V_{OH}$	Output logic level, high	$I_{OH} = -2\text{ mA}$	$0.8 \times DV_{DD}$		V
$V_{OL}$	Output logic level, low	$I_{OL} = 2\text{ mA}$	$0.22 \times DV_{DD}$		V
<b>Dynamic Performance (PCM Mode)<sup>(1)(2)</sup></b>					
THD+N at -1 dBFS <sup>(2)</sup>	$f_S = 48\text{ kHz}$		-93	-83	dB
	$f_S = 96\text{ kHz}$		-93		
	$f_S = 192\text{ kHz}$		-93		
Dynamic range <sup>(2)</sup>	EIAJ, A-weighted, $f_S = 48\text{ kHz}$	108	114		dB
	EIAJ, A-weighted, $f_S = 96\text{ kHz}$		114		
	EIAJ, A-weighted, $f_S = 192\text{ kHz}$		114		
Signal-to-noise ratio <sup>(2)</sup>	EIAJ, A-weighted, $f_S = 48\text{ kHz}$		114		dB
	EIAJ, A-weighted, $f_S = 96\text{ kHz}$		114		
	EIAJ, A-weighted, $f_S = 192\text{ kHz}$		114		
Signal to noise ratio with analog mute <sup>(2)(3)</sup>	EIAJ, A-weighted, $f_S = 48\text{ kHz}$	113	123		dB
	EIAJ, A-weighted, $f_S = 96\text{ kHz}$	113	123		
	EIAJ, A-weighted, $f_S = 192\text{ kHz}$	113	123		
Channel separation	$f_S = 48\text{ kHz}$	100 / 95	109 / 103		dB
	$f_S = 96\text{ kHz}$	100 / 95	109 / 103		
	$f_S = 192\text{ kHz}$	100 / 95	109 / 103		

- (1) Filter condition: THD+N: 20-Hz HPF, 20-kHz AES17 LPF; Dynamic range: 20-Hz HPF, 20-kHz AES17 LPF; A-weighted signal-to-noise ratio: 20-Hz HPF, 20-kHz AES17 LPF; A-weighted channel separation: 20-Hz HPF, 20-kHz AES17 LPF. Analog performance specifications are measured using the System Two Cascade™ audio measurement system by Audio Precision™ in the RMS mode.
- (2) Output load is 10 k $\Omega$ , with 470- $\Omega$  output resistor and a 2.2-nF shunt capacitor (see recommended output filter).
- (3) Assert XSMT or both L-ch and R-ch PCM data are Bipolar Zero.



## Electrical Characteristics (continued)

All specifications at  $T_A = 25^\circ\text{C}$ ,  $AV_{DD} = CPV_{DD} = DV_{DD} = 3.3\text{V}$ ,  $f_S = 48\text{kHz}$ , system clock =  $512 f_S$  and 24-bit data unless otherwise noted.

PARAMETER		TEST CONDITIONS	MIN	TYP	MAX	UNIT
<b>Analog Output</b>						
Single Ended Output voltage				2.1		$V_{RMS}$
Differential Output Voltage				4.2		$V_{RMS}$
Gain error			-6	$\pm 2$	6	% of FSR
Gain mismatch, channel-to-channel			-6	$\pm 2$	6	% of FSR
Bipolar zero error (per pin)	At bipolar zero		-2	$\pm 1$	2	mV
Load impedance			5			k $\Omega$
<b>Filter Characteristics–1: Normal (8x)</b>						
Pass band					$0.45f_S$	
Stop band			$0.55f_S$			
Stop band attenuation			-60			dB
Pass-band ripple					$\pm 0.02$	dB
Delay time				$20f_S$		s
<b>Filter Characteristics–2: Low Latency (8x)</b>						
Pass band					$0.47f_S$	
Stop band			$0.55f_S$			
Stop band attenuation			-52			dB
Pass-band ripple					$\pm 0.0001$	dB
Delay time				$3.5f_S$		s
<b>Filter Characteristics–3: Asymmetric FIR (8x)</b>						
Pass band					$0.40f_S$	
Stop band			$0.72f_S$			
Stop band attenuation			-52			dB
Pass-band ripple					$\pm 0.05$	dB
Delay time				$1.2f_S$		s
<b>Filter Characteristics–4: High-Attenuation (8x)</b>						
Pass band					$0.45f_S$	
Stop band			$0.45f_S$			
Stop band attenuation			-100			dB
Pass-band ripple					$\pm 0.0005$	dB
Delay time				$33.7f_S$		s
<b>Power Supply Requirements</b>						
$DV_{DD}$	Digital supply voltage	Target $DV_{DD} = 1.8\text{V}$	1.65	1.8	1.95	VDC
$DV_{DD}$	Digital supply voltage	Target $DV_{DD} = 3.3\text{V}$	3	3.3	3.6	VDC
$AV_{DD}$	Analog supply voltage		3	3.3	3.6	VDC
$CPV_{DD}$	Charge-pump supply voltage		3	3.3	3.6	VDC
$I_{DD}$	$DV_{DD}$ supply current at 1.8 V	$f_S = 48\text{kHz}$ , Input is Bipolar Zero data		11	14	mA
		$f_S = 96\text{kHz}$ , Input is Bipolar Zero data		12		
		$f_S = 192\text{kHz}$ , Input is Bipolar Zero data		14		
$I_{DD}$	$DV_{DD}$ supply current at 1.8 V	$f_S = 48\text{kHz}$ , Input is 1kHz -1dBFS data		11	14	mA
		$f_S = 96\text{kHz}$ , Input is 1kHz -1dBFS data		12		
		$f_S = 192\text{kHz}$ , Input is 1kHz -1dBFS data		14		
$I_{DD}$	$DV_{DD}$ supply current at 1.8 V <sup>(4)</sup>	$f_S = \text{N/A}$ , Power Down Mode		0.3	0.6	mA
$I_{DD}$	$DV_{DD}$ supply current at 3.3 V	$f_S = 48\text{kHz}$ , Input is Bipolar Zero data		12	15	mA
		$f_S = 96\text{kHz}$ , Input is Bipolar Zero data		13		
		$f_S = 192\text{kHz}$ , Input is Bipolar Zero data		15		

(4) Power Down Mode, with LRCK, BCK, and SCK halted at Low level.

**Electrical Characteristics (continued)**

All specifications at  $T_A = 25^\circ\text{C}$ ,  $AV_{DD} = CPV_{DD} = DV_{DD} = 3.3\text{V}$ ,  $f_S = 48\text{kHz}$ , system clock =  $512 f_S$  and 24-bit data unless otherwise noted.

PARAMETER		TEST CONDITIONS	MIN	TYP	MAX	UNIT
$I_{DD}$	DV <sub>DD</sub> supply current at 3.3 V	$f_S = 48\text{ kHz}$ , Input is 1kHz -1dBFS data		12	15	mA
		$f_S = 96\text{ kHz}$ , Input is 1kHz -1dBFS data		13		
		$f_S = 192\text{ kHz}$ , Input is 1kHz -1dBFS data		15		
$I_{DD}$	DV <sub>DD</sub> supply current at 3.3 V <sup>(4)</sup>	$f_S = \text{N/A}$ , Power Down Mode		0.5	0.8	mA
$I_{CC}$	AV <sub>DD</sub> / CPV <sub>DD</sub> supply current	$f_S = 48\text{ kHz}$ , Input is Bipolar Zero data		11	16	mA
		$f_S = 96\text{ kHz}$ , Input is Bipolar Zero data		11		
		$f_S = 192\text{ kHz}$ , Input is Bipolar Zero data		11		
$I_{CC}$	AV <sub>DD</sub> / CPV <sub>DD</sub> supply current	$f_S = 48\text{ kHz}$ , Input is 1kHz -1dBFS data		24	32	mA
		$f_S = 96\text{ kHz}$ , Input is 1kHz -1dBFS data		24		
		$f_S = 192\text{ kHz}$ , Input is 1kHz -1dBFS data		24		
$I_{CC}$	AV <sub>DD</sub> / CPV <sub>DD</sub> supply current <sup>(4)</sup>	$f_S = \text{N/A}$ , Power Down Mode		0.2	0.4	mA
	Power dissipation, DV <sub>DD</sub> = 1.8 V	$f_S = 48\text{ kHz}$ , Input is Bipolar Zero data		59.4	78	mW
		$f_S = 96\text{ kHz}$ , Input is Bipolar Zero data		61.2		
		$f_S = 192\text{ kHz}$ , Input is Bipolar Zero data		64.8		
	Power dissipation, DV <sub>DD</sub> = 1.8 V	$f_S = 48\text{ kHz}$ , Input is 1kHz -1dBFS data		99	130.8	mW
		$f_S = 96\text{ kHz}$ , Input is 1kHz -1dBFS data		100.8		
		$f_S = 192\text{ kHz}$ , Input is 1kHz -1dBFS data		104.4		
	Power dissipation, DV <sub>DD</sub> = 1.8 V <sup>(4)</sup>	$f_S = \text{N/A}$ (Power Down Mode)		1.2		mW
	Power dissipation, DV <sub>DD</sub> = 3.3 V	$f_S = 48\text{ kHz}$ , Input is Bipolar Zero data		79.2	103	mW
		$f_S = 96\text{ kHz}$ , Input is Bipolar Zero data		82.5		
		$f_S = 192\text{ kHz}$ , Input is Bipolar Zero data		89.1		
	Power dissipation, DV <sub>DD</sub> = 3.3 V	$f_S = 48\text{ kHz}$ , Input is 1kHz -1dBFS data		118.8	155	mW
		$f_S = 96\text{ kHz}$ , Input is 1kHz -1dBFS data		122.1		
		$f_S = 192\text{ kHz}$ , Input is 1kHz -1dBFS data		128.7		
	Power dissipation, DV <sub>DD</sub> = 3.3 V <sup>(4)</sup>	$f_S = \text{N/A}$ (Power Down Mode)		2.3	4	mW

## 7.6 Switching Characteristics

over operating free-air temperature range (unless otherwise noted)

PARAMETER	TEST CONDITIONS	MIN	TYP	MAX	UNIT
<b>DATA FORMAT (PCM MODE)</b>					
Audio data interface format		I <sup>2</sup> S, left-justified, right-justified, and TDM			
Audio data bit length		16, 20, 24, 32-bit acceptable			
Audio data format		MSB first, twos-complement			
f <sub>S</sub> Sampling frequency <sup>(1)</sup>		8		384	kHz
<b>CLOCKS</b>					
System clock frequency		64, 128, 192, 256, 384, 512, 768, 1024, 1152, 1536, 2048, or 3072 f <sub>SCK</sub> , up to 50 MHz			
PLL input frequency <sup>(2)</sup>	Clock divider uses fractional divide D > 0, P=1	6.7		20	MHz
	Clock divider uses integer divide D = 0, P=1	1		20	MHz

(1) One sample time is defined as the reciprocal of the sampling frequency.  $1 \times t_s = 1 / f_s$

(2) With the appropriate P coefficient setting, the PLL accepts up to 50 MHz. This clock is then divided to meet the ≤ 20-MHz requirement. See [PLL Calculation](#).

## 7.7 Timing Requirements: SCK Input

Figure 4 shows the timing requirements for the system clock input. For optimal performance, use a clock source with low phase jitter and noise.

		MIN	NOM	MAX	UNIT
t <sub>SCY</sub>	System clock pulse cycle time	20		1000	ns
t <sub>SCKH</sub>	System clock pulse width, high	DVDD = 1.8 V	8		ns
		DVDD = 3.3 V	9		
t <sub>SCKL</sub>	System clock pulse width, low	DVDD = 1.8 V	8		ns
		DVDD = 3.3 V	9		

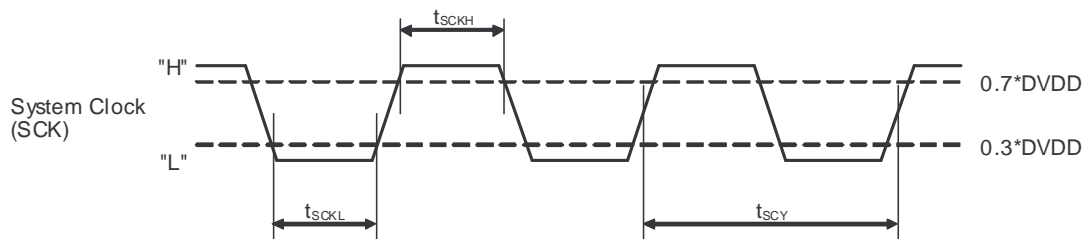


Figure 4. Timing Requirements for SCK Input

### 7.8 Timing Requirements: PCM Audio Data

		MIN	NOM	MAX	UNIT
$t_{BCY}$	BCK Pulse Cycle Time	40			ns
$t_{BCL}$	BCK Pulse Width LOW	16			ns
$t_{BCH}$	BCK Pulse Width HIGH	16			ns
$t_{BL}$	BCK Rising Edge to LRCK Edge	8			ns
$t_{BCK}$	BCK frequency at DVDD = 3.3V			24.576	MHz
$t_{BCK(1.8V)}$	BCK frequency at DVDD = 1.8V			12.288	MHz
$t_{LB}$	LRCK Edge to BCK Rising Edge	8			ns
$t_{DS}$	DATA Set Up Time	8			ns
$t_{DH}$	DATA Hold Time	8			ns
$t_{DOD}$	DATA delay time from BCK falling edge			15	ns

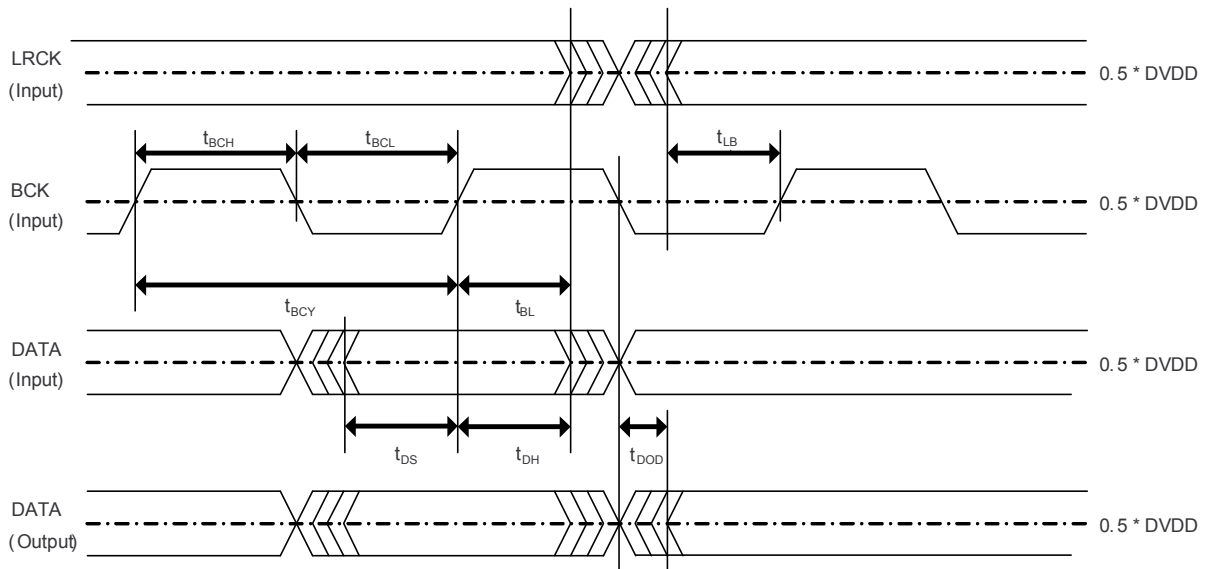


Figure 5. PCM5252 Serial Audio Timing - Slave

In software mode, The PCM5252 can act as an I<sup>2</sup>S master, generating BCK and LRCK as outputs from the SCK input.

Table 3. I<sup>2</sup>S Master Mode Registers

Register	Function
Page0, Register 9, D(0), D(4), and D(5)	I <sup>2</sup> S Master mode select
Register 32, D(6:0)	
Register 33, D(7:0)	BCK divider and LRCK divider

### 7.9 Timing Requirements: I<sup>2</sup>S Master, See Figure 6

		MIN	NOM	MAX	UNIT
$t_{BCY}$	BCK Pulse Cycle Time	40			ns
$t_{BCL}$	BCK Pulse Width LOW	16			ns
$t_{BCH}$	BCK Pulse Width HIGH	16			ns
$t_{BCK}$	BCK frequency at DVDD = 3.3 V			24.576	MHz
$t_{BCK(1.8V)}$	BCK frequency at DVDD = 1.8 V			12.288	MHz
$t_{LRD}$	LRCKx delay time from BCKx falling edge	-10		20	ns
$t_{DS}$	DATA Set Up Time	8			ns

Timing Requirements: I<sup>2</sup>S Master, See Figure 6 (continued)

		MIN	NOM	MAX	UNIT
t <sub>DH</sub>	DATA Hold Time	8			ns
t <sub>DOD</sub>	DATA delay time from BCK falling edge at DVDD = 3.3 V			15	ns
t <sub>DOD(1.8V)</sub>	DATA delay time from BCK falling edge at DVDD = 1.8 V			20	ns

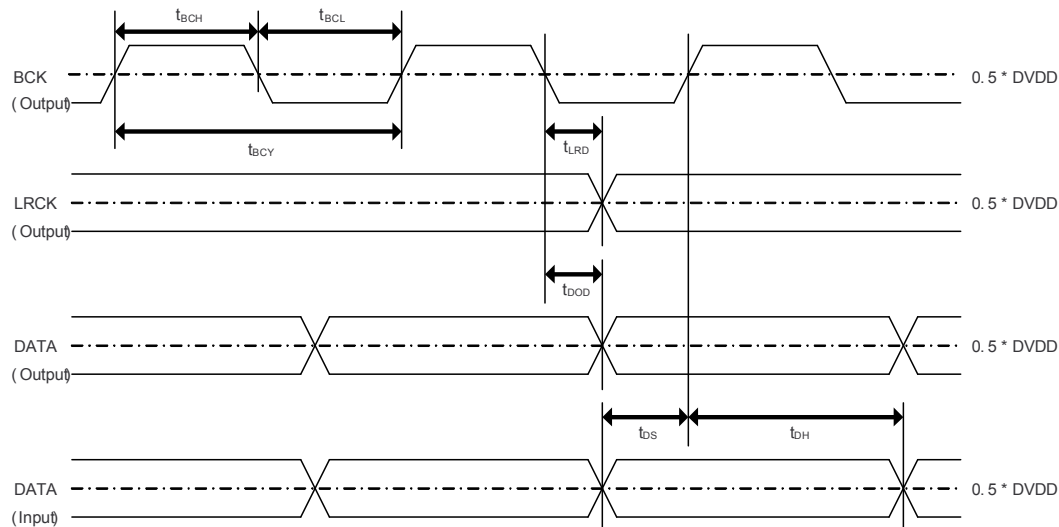


Figure 6. PCM5252 Serial Audio Timing - I<sup>2</sup>S Master

7.10 Timing Requirements: XSMT

		MIN	NOM	MAX	UNIT
t <sub>r</sub>	Rise time			20	ns
t <sub>f</sub>	Fall time			20	ns

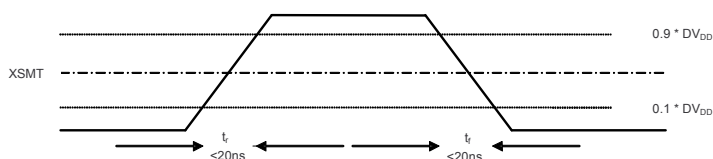
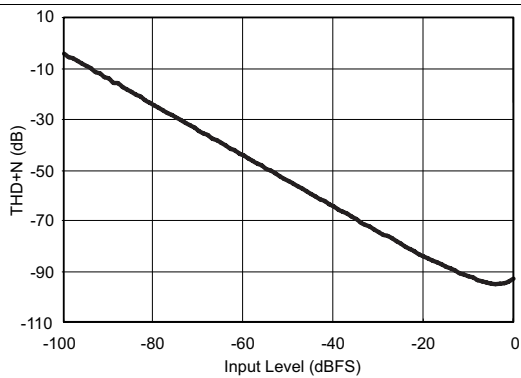


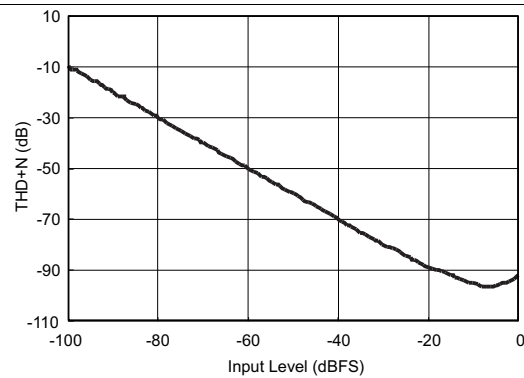
Figure 7. XSMT Timing for Soft Mute and Soft Un-Mute

## 7.11 Typical Characteristics

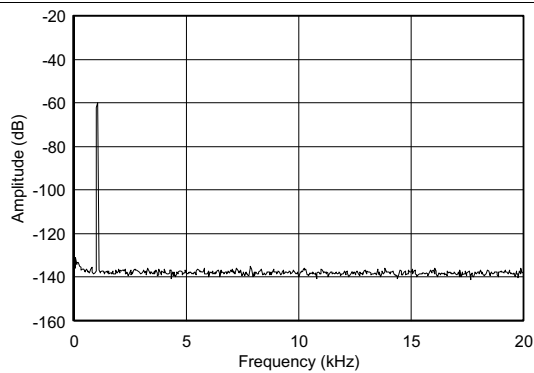
All specifications at  $T_A = 25^\circ\text{C}$ ,  $AV_{DD} = CPV_{DD} = DV_{DD} = 3.3\text{V}$ ,  $f_S = 48\text{kHz}$ , system clock =  $512 f_S$  and 24-bit data unless otherwise noted.



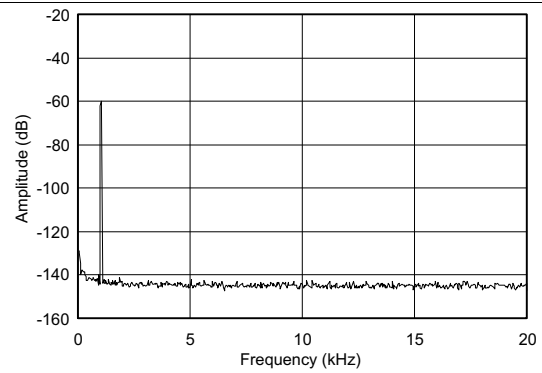
**Figure 8. THD+N vs Input Level**



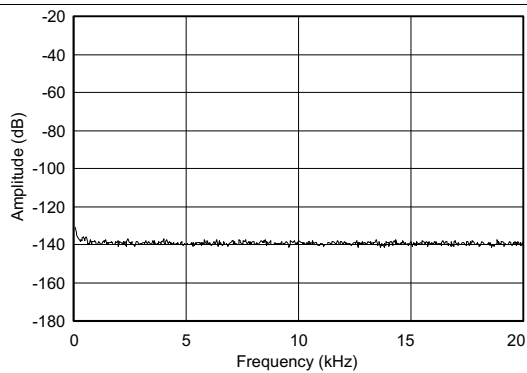
**Figure 9. THD+N vs Input Level**



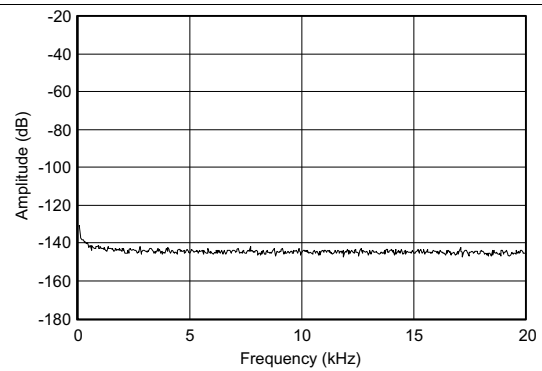
**Figure 10. FFT Plot At -60 db Input**



**Figure 11. FFT Plot At -60 db Input**



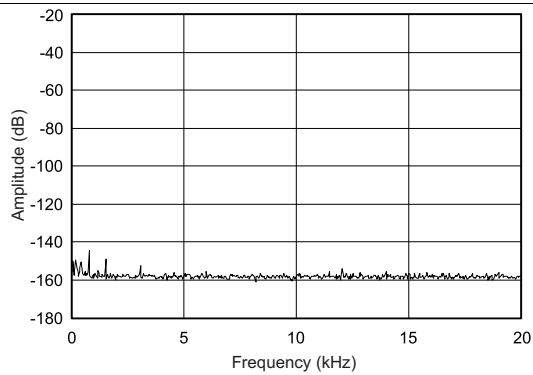
**Figure 12. FFT Plot at Bipolar Zero Data (BPZ)**



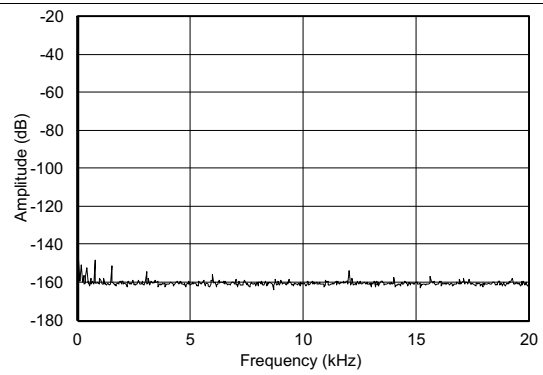
**Figure 13. FFT Plot at BPZ**

**Typical Characteristics (continued)**

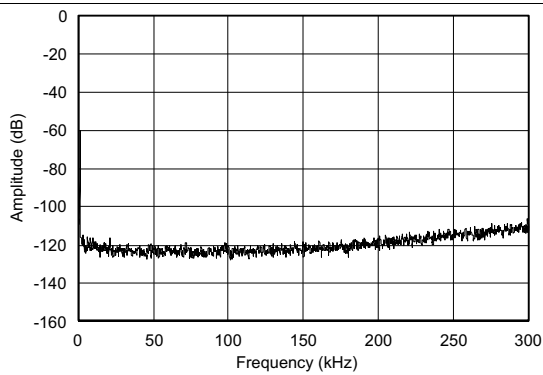
All specifications at  $T_A = 25^\circ\text{C}$ ,  $AV_{DD} = CPV_{DD} = DV_{DD} = 3.3\text{V}$ ,  $f_s = 48\text{kHz}$ , system clock =  $512 f_s$  and 24-bit data unless otherwise noted.



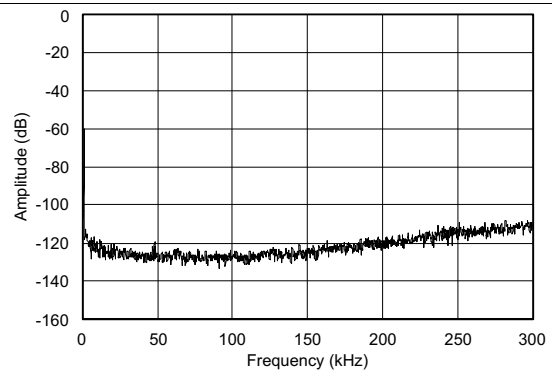
**Figure 14. FFT Plot at BPZ With Analog Mute (AMUTE)**



**Figure 15. FFT Plot at BPZ With Analog Mute (AMUTE)**



**Figure 16. FFT Plot at -60 dB to 300 khz**



**Figure 17. FFT Plot at -60 dB to 300 khz**

## 8 Detailed Description

### 8.1 Overview

The PCM5252 PurePath™ Smart Amp enhances the bass, sound fidelity and increased loudness by driving the speaker to its thermal and mechanical limits.

TI's PurePath™ Smart Amp technology allows speakers to be driven with more peak power than their average-power rating, without damage to the speaker by voice coil over excursion or thermal overload.

Sophisticated speaker models (electro-mechanical-thermal) are used as a foundation for the protection and enhancement of the system. This is done by modeling the loudspeaker in the on-chip miniDSP and running an adaptive algorithm that modifies the output based on the modeled conditions of the speaker.

TI provides a PurePath™ Console (PPC) GUI, including a TI learning board that measures the loudspeaker parameters. The PPC GUI generates the code for download to the device on boot-up.

Smart Amp technology in the PCM5252 devices use information from the SOA (Safe Operating Area) characterization details for the loudspeaker, as well as real-world temperature, and uses this data in an adaptive control algorithm in order to control Smart Bass and Smart DRP (Dynamic Range Preservation). The protection side of the algorithm is also used for thermal protection and mechanical voice coil excursion protection.

The integrated PLL on the device provided adds the flexibility to remove the system clock (commonly known as master clock), allowing a 3-wire I<sup>2</sup>S connection and reducing system EMI. In addition, the PLL is completely programmable, allowing the device to become the I<sup>2</sup>S clock master and drive a DSP serial port as a slave. The PLL also accepts a non-standard clock (up to 50 MHz) as a source to generate the audio related clock (for example, 24.576 MHz).

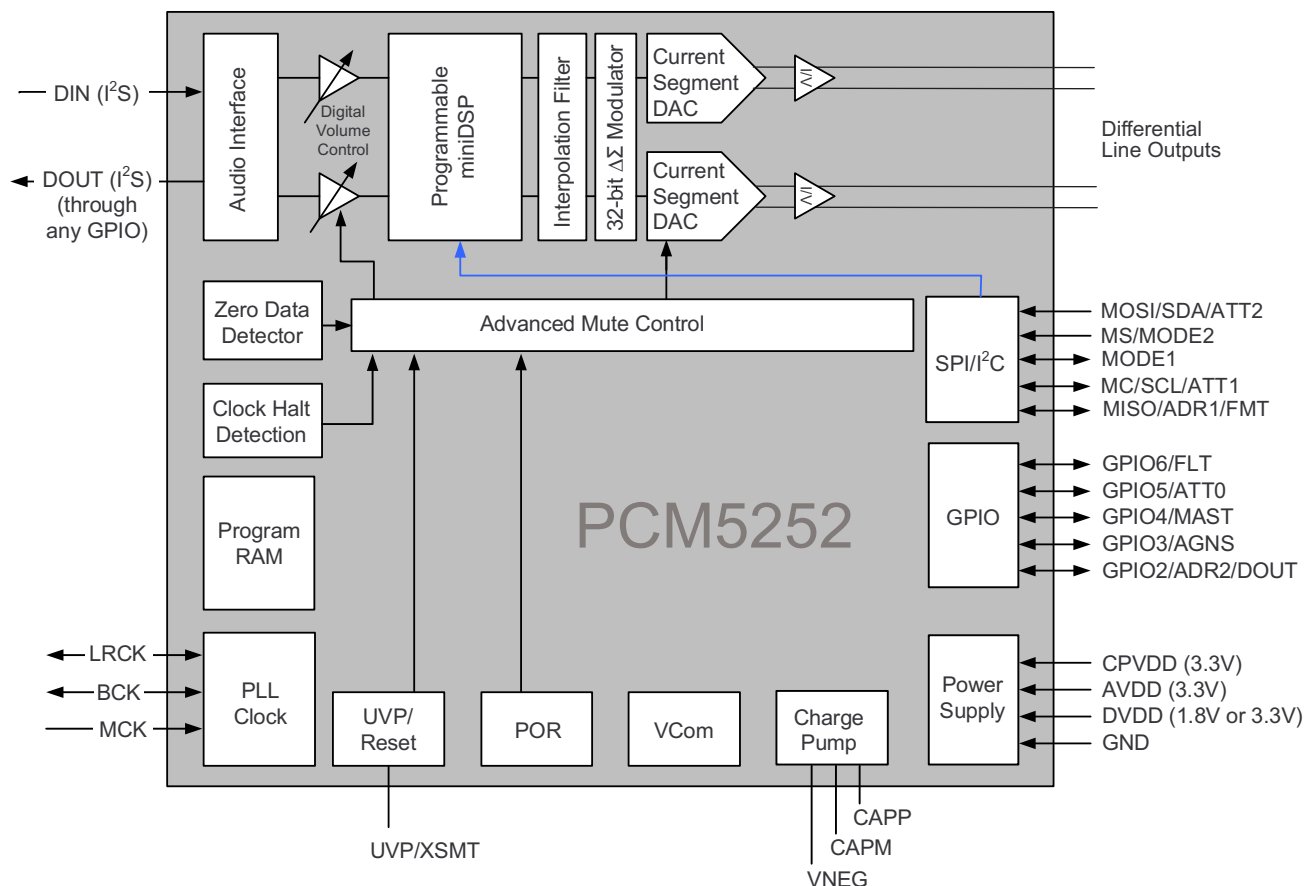
Powersense undervoltage protection utilizes a two-level mute system. Upon clock error or system power failure, the device digitally attenuates the data (or last known good data) and then mutes the analog circuit.

Compared with existing DAC technology, the PCM5252 devices offer up to 20 dB of lower out-of-band noise, reducing EMI and aliasing in downstream amplifiers/ADCs (from traditional 100-kHz OBN measurements to 3 MHz).

The PCM5252 devices accept industry-standard audio data formats with 16-bit to 32-bit data. Sample rates up to 384 kHz are supported.



## 8.2 Functional Block Diagram



## 8.3 Feature Description

### 8.3.1 Terminology

Control registers in this data sheet are given by **REGISTER BIT/BYTE NAME (Page.x HEX ADDRESS)**. SE refers to *single-ended* analog inputs, DIFF refers to *Differential* analog inputs. SCK (System Clock) and MCLK (Master Clock) are used interchangeably. Sampling frequency is symbolized by  $f_s$ . Full scale is symbolized by FS. Sample time as a unit is symbolized by  $t_s$ .

## Feature Description (continued)

### 8.3.2 Audio Data Interface

#### 8.3.2.1 Audio Serial Interface

The audio interface port is a 3-wire serial port with the signals LRCK, BCK, and DIN. BCK is the serial audio bit clock, used to clock the serial data present on DIN into the serial shift register of the audio interface. Serial data is clocked into the PCM5252 on the rising edge of BCK. LRCK is the serial audio left/right word clock. LRCK polarity for left/right is given by the format selected.

**Table 4. PCM5252 Audio Data Formats, Bit Depths and Clock Rates**

CONTROL MODE	FORMAT	DATA BITS	MAX LRCK FREQUENCY [ $f_s$ ]	SCK RATE [ $\times f_s$ ]	BCK RATE [ $\times f_s$ ]
Software Control (SPI or I <sup>2</sup> S)	I <sup>2</sup> S/LJ	32, 24, 20, 16	Up to 192 kHz	128 – 3072	64, 48, 32
			384 kHz	64, 128	64, 48, 32
	TDM/DSP	32, 24, 20, 16	Up to 48 kHz	128 – 3072	128, 256
			96 kHz	128 – 512	128, 256
Hardware Control	I <sup>2</sup> S/LJ	32, 24, 20, 16	Up to 192 kHz	128 – 3072	64, 48, 32
			384 kHz	64, 128	64, 48, 32
			192 kHz	128, 192, 256	128

The PCM5252 requires the synchronization of LRCK and system clock, but does not need a specific phase relation between LRCK and system clock.

If the relationship between LRCK and system clock changes more than  $\pm 5$  SCK, internal operation (using an onchip oscillator) is initialized within one sample period and analog outputs are forced to the bipolar zero level until resynchronization between LRCK and system clock is completed.

If the relationship between LRCK and BCK are invalid more than 4 LRCK periods, internal operation (using an onchip oscillator) is initialized within one sample period and analog outputs are forced to the bipolar zero level until resynchronization between LRCK and BCK is completed.

### 8.3.2.2 PCM Audio Data Formats

The PCM5252 supports industry-standard audio data formats, including standard I<sup>2</sup>S and left-justified. Data formats are selected via Register (Pg0Reg40). All formats require binary twos-complement, MSB-first audio data; up to 32-bit audio data is accepted.

The PCM5252 also supports right-justified and TDM/DSP in software control mode. I<sup>2</sup>S, LJ, RJ, and TDM/DSP are selected using Register (Pg0Reg40). All formats require binary twos-complement, MSB-first audio data. Up to 32 bits are accepted. Default setting is I<sup>2</sup>S and 24-bit word length.

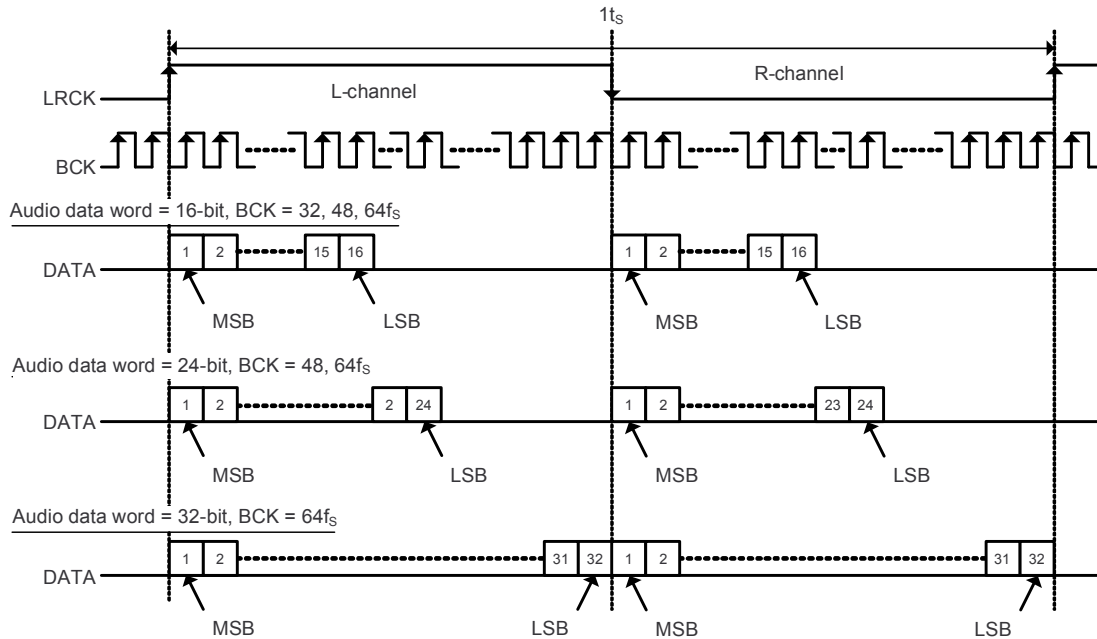
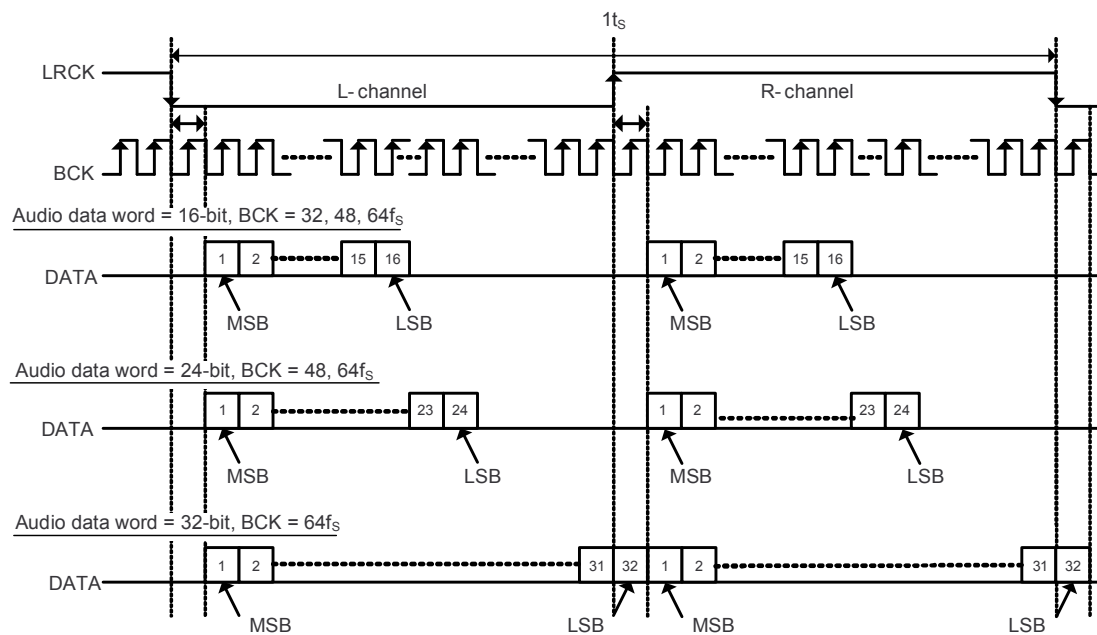


Figure 18. Left-Justified Audio Data Format

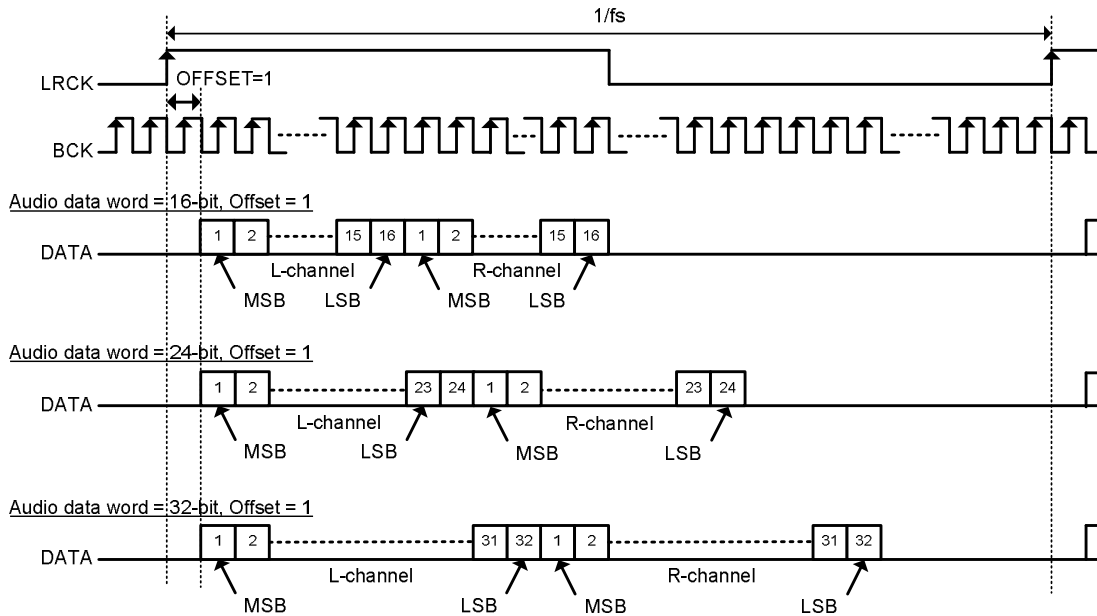


I<sup>2</sup>S Data Format; L-channel = LOW, R-channel = HIGH

Figure 19. I<sup>2</sup>S Audio Data Format

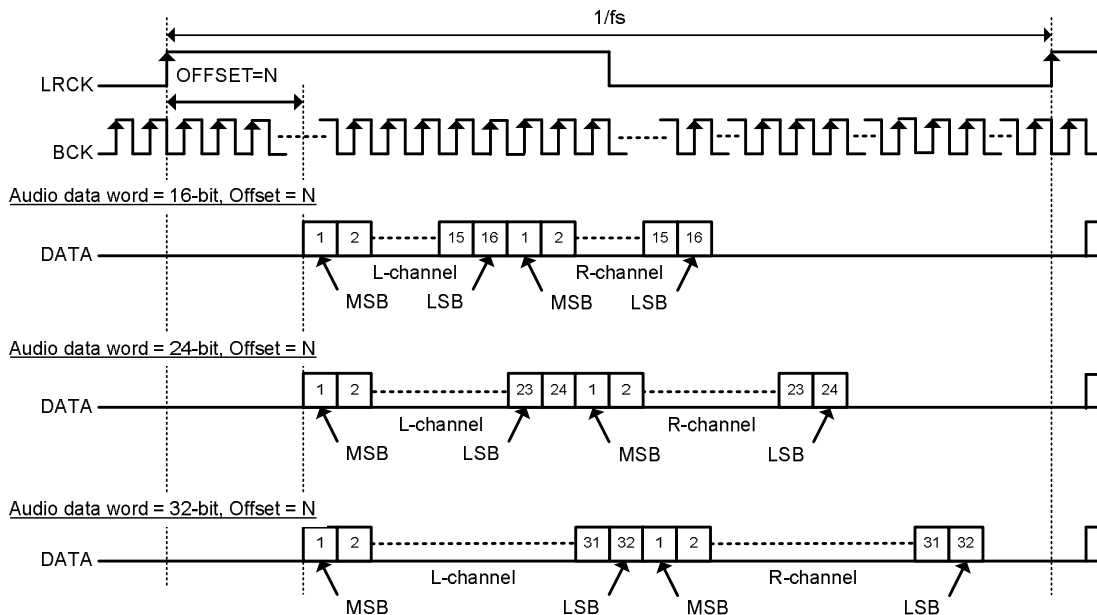
**NOTE**

In TDM Modes, Duty Cycle of LRCK should be 1x BCK at minimum. Rising edge is considered frame start.



TDM/DSP Data Format; L-channel = FIRST, R-channel = LAST with OFFSET = 1

**Figure 20. TDM/DSP 2 Audio Data Format**



TDM/DSP Data Format; L-channel = FIRST, R-channel = LAST with OFFSET = N

**Figure 21. TDM/DSP 3 Audio Data Format**

### 8.3.2.3 Zero Data Detect

The PCM5252 has a zero-detect function. When the device detects the continuous zero data for both left and right channels, or separate channels, Analog mutes are set to both OUTL and OUTR, or separate OUTL and OUTR. These are controlled by Page 0, Register 65, D(2:1) as shown in [Table 5](#).

**Table 5. Zero Data Detection Mode**

ATMUTECTL	VALUE	FUNCTION
Bit : 2	0	Independently L-ch or R-ch are zero data for zero data detection
	1 (Default)	Both L-ch and R-ch have to be zero data for zero data detection
Bit : 1	0	Zero detection and analog mute are disabled for R-ch
	1 (Default)	Zero detection analog mute are enabled for R-ch
Bit : 0	0	Zero detection analog mute are disabled for L-ch
	1 (Default)	Zero detection analog mute are enabled for L-ch

**Table 6. Zero Data Detection Time**

ATMUTETIML / ATMUTETIMR	NUMBER OF LRCKs	TIME AT 48 kHz
0 0 0	1024	21 ms
0 0 1	5120	106 ms
0 1 0	10240	213 ms
0 1 1	25600	533 ms
1 0 0	51200	1.066 sec
1 0 1	102400	2.133 sec
1 1 0	256000	5.333 sec
1 1 1	512000	10.66 sec

### 8.3.3 XSMT Pin (Soft Mute / Soft Un-Mute)

An external digital host controls the PCM5252 soft mute function by driving the XSMT pin with a specific minimum rise time ( $t_r$ ) and fall time ( $t_f$ ) for soft mute and soft un-mute. The PCM5252 requires  $t_r$  and  $t_f$  times of less than 20 ns. In the majority of applications, this is no problem; however, traces with high capacitance may have issues.

When the XSMT pin is shifted from high to low (3.3 V to 0 V), a soft digital attenuation ramp begins. –1-dB attenuation is then applied every sample time from 0 dBFS to  $-\infty$ . The soft attenuation ramp takes 104 samples.

When the XSMT pin is shifted from low to high (0 V to 3.3 V), a soft digital *un-mute* is started. 1-dB gain steps are applied every sample time from  $-\infty$  to 0 dBFS. The un-mute takes 104 samples.

In systems where XSMT is not required, it can be directly connected to AVDD.

### 8.3.4 Audio Processing

#### 8.3.4.1 PCM5252 Audio Processing Options

##### 8.3.4.1.1 Overview

The PCM5252 features a programmable miniDSP core that offers Hybrid-Flows which are a RAM/ROM combination of code. Common functions are embedded in ROM, and custom RAM flows, created by TI can be run on the miniDSP core. The algorithms for the miniDSP must be loaded into the device after power up. The miniDSP can run up to 1024 instructions on every audio sample at a 48kHz sample rate. Development is done using Purepath™ Console software.

---

#### NOTE

At higher sampling frequencies, fewer instruction cycles are available. (For example, 512 instructions can be done in a 96-kHz frame.)

---

The PCM5252 supports two different code sources. ROM based process flow (See the next section for how to select) and RAM based process flow. In program 31 (RAM based), different algorithms can be called from ROM - such as EQ, DRC and Zero Crossing volume control. Please see the PurePath Studio Development Environment for more details.

Smart Amplifier is another process flow that is available for use. Program 5 integrates a 2.1 Smart Amplifier system, without Smart Bass enhancement. A mixed RAM/ROM Mode is available using program 31 that can do a 2.0 Stereo Smart Amplifier with Smart Bass enhancement. However, the MIPS requirements for Smart Amplifier allow the process flow to work up to 48kHz sampling rate. Any higher sampling rates will require a custom process flow with limited processing (such as a simpler EQ and Dynamic Range Control),

##### 8.3.4.1.2 miniDSP Instruction Register

Registers on Page 152-169 are 25-bit instructions for the miniDSP engine. For details, see [Table 43](#). 7 bits of Instr(32:25) in Base register +0 are reserved bits. 1 bit of Instr(24) - (LSB) in Base register +0 is MSB bit of 25 bit instruction. These instructions control miniDSP operation. When the fully programmable miniDSP mode is enabled and the DAC channel is powered up, the read and write access to these registers is disabled.

##### 8.3.4.1.3 Digital Output

The PCM5252 supports an SDOUT output. This can be selected within the process flow, and driven out of a GPIO pin selected in the register map (for example, Page 0 / Register 80). Users should note that the I<sup>2</sup>S output will be attenuated by 0.5 dB. A full scale (FS) output will actually be FS-0.5dB. This can be compensated for within the process flow using PurePath Studio. The I<sup>2</sup>S output can be a separate audio stream to the analog DAC output, allowing 2.1 and 2.2 systems to be implemented. By default, the SDOUT is not linked to the volume control registers on Page 0 / Register 60, 61, 62. However, it is possible to configure the SDOUT component in Purepath studio to mirror that register.

##### 8.3.4.1.4 Software

Software development for the PCM5252 is supported through TI's comprehensive PurePath Console; a powerful, easy-to-use tool designed specifically to simplify software development on the PCM5252 miniDSP audio platform. The Graphical Development Environment consists of number of Hybrid Flows that can be downloaded to the device and run on the miniDSP.

Please visit the PCM5252 product folder on [www.ti.com](http://www.ti.com) to learn more about PurePath Console and the latest status on available, ready-to-use DSP algorithms.

### 8.3.4.2 Interpolation Filter

The PCM5252 provides 4 types of interpolation filters, selectable by writing to Page 0, Register 43, D(4:0).

Additional RAM based Hybrid Flows can be implemented by selecting Program 31, and downloading instructions and coefficients to the device.

**Table 7. ROM Preset Programs**

PROGRAM NUMBER	D(4:0)	DESCRIPTION	MINIMUM CYCLES
0	0 0000	Reserved	
1	0 0001	Normal x8/x4/x2/x1 Interpolation Filter <sup>(1)</sup>	256
2	0 0010	Low Latency x8/x4/x2/x1 Interpolation Filter <sup>(1)</sup>	256
3	0 0011	High Attenuation x8/x4/x2 Interpolation Filter <sup>(1)</sup>	512
4	0 0100	Reserved	
5	0 0101	Reserved	
6	0 0110	Reserved	
7	0 0111	Asymmetric FIR Interpolation Filter <sup>(1)</sup>	512
:	:	Reserved	
31	1 1111	RAM Process flow (e.g. can be used to implement Smart Amplifier 2.1 Mode)	

(1) At  $f_s=44.1$  kHz, de-emphasis filter is supported.

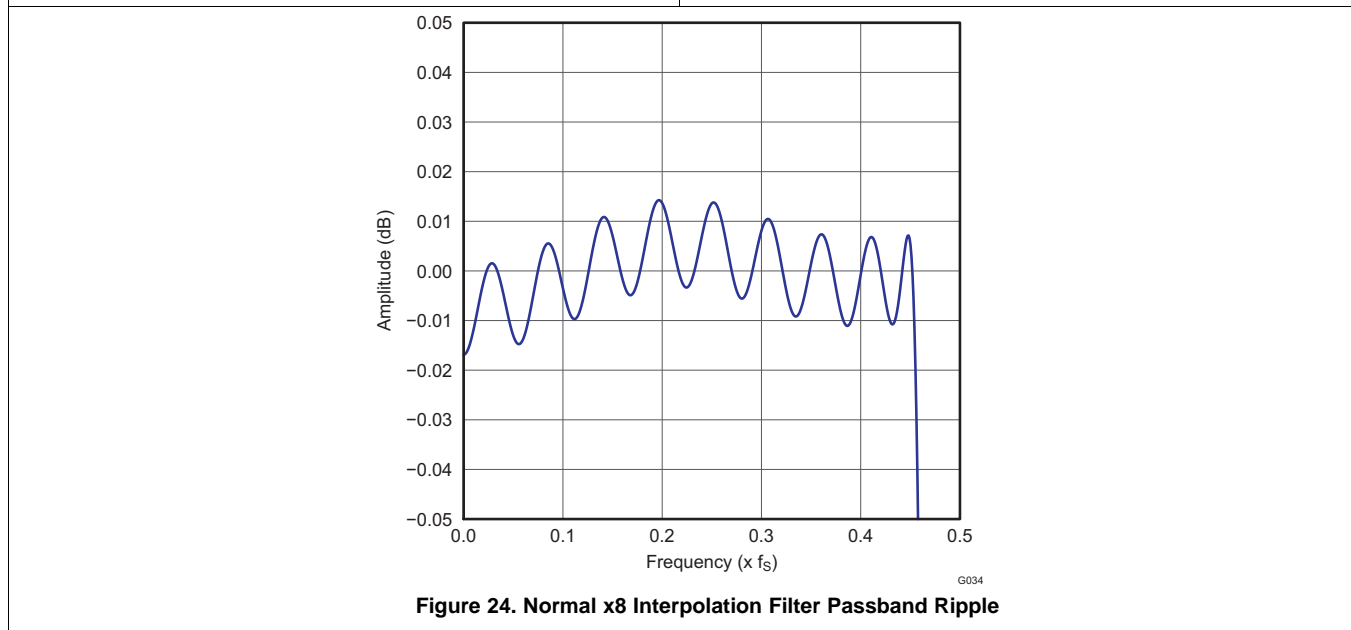
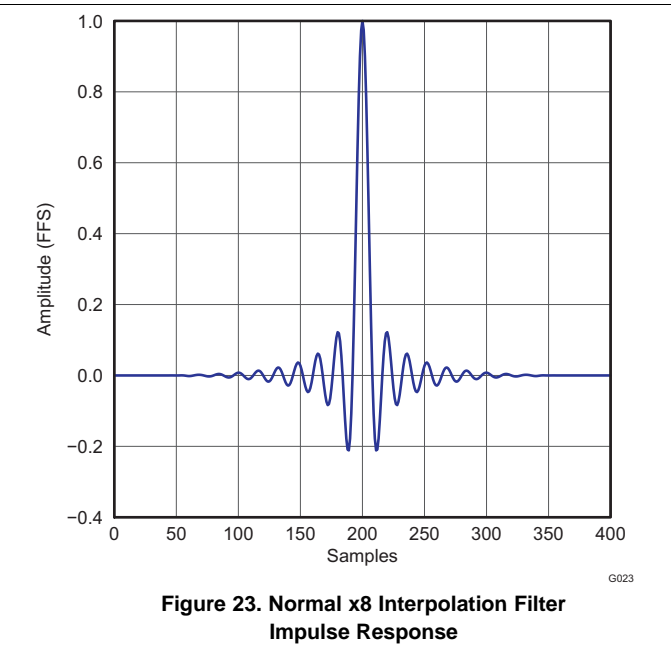
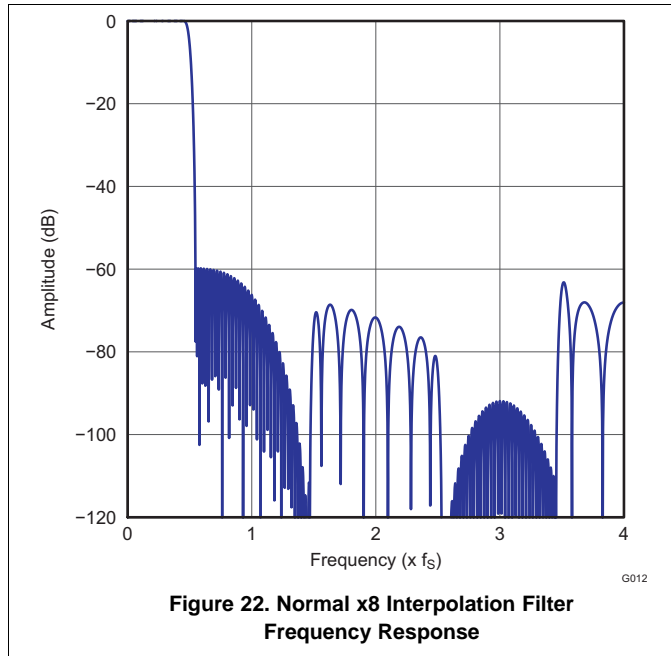
The PCM5252 supports four sampling modes (single rate, dual rate, quad rate, and octal rate) which produce different oversampling rates (OSR) in the interpolation digital filter operation. These are shown in [Table 8](#).

**Table 8. Sampling Modes and Oversampling Rates**

SAMPLING MODE	SAMPLING FREQUENCY ( $f_s$ ) kHz	OVERSAMPLING RATE (OSR)
Single Rate	8	8 or 16
	16	
	32	
	44.1	
	48	
Dual Rate	88.2	4
	96	
Quad Rate	176.4	2
	192	
Octal Rate	384	1 (Bypass)

**Table 9. Normal x8 Interpolation Filter, Single Rate**

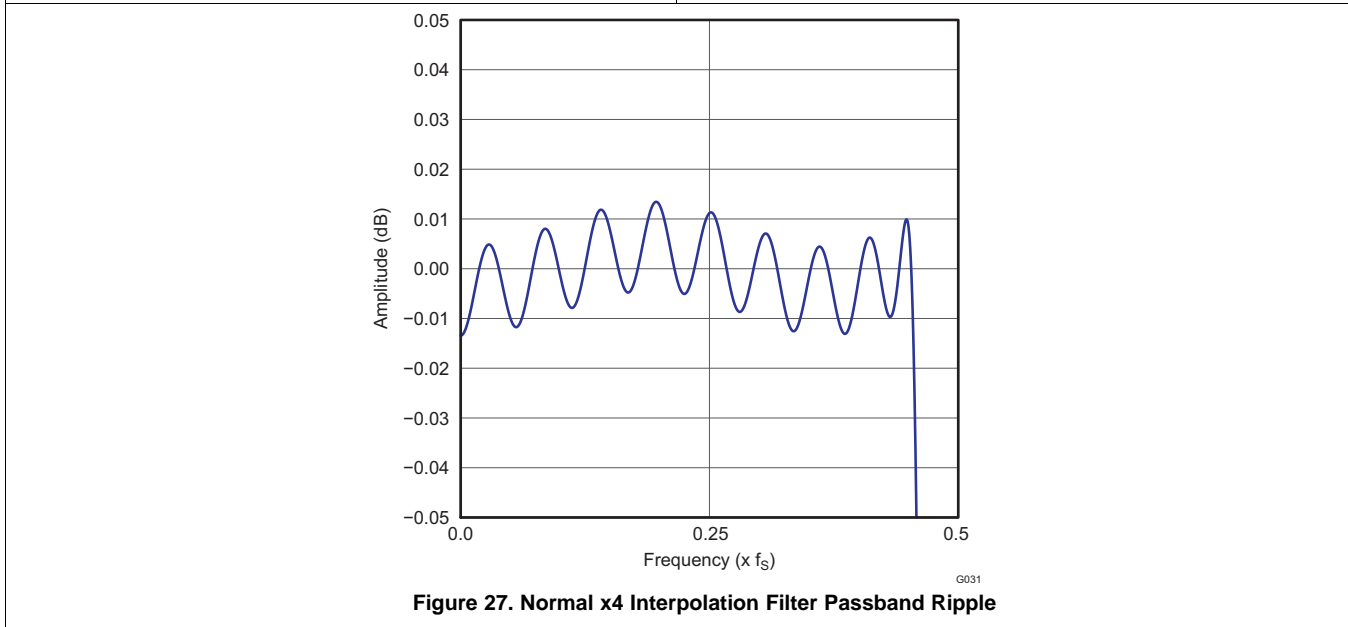
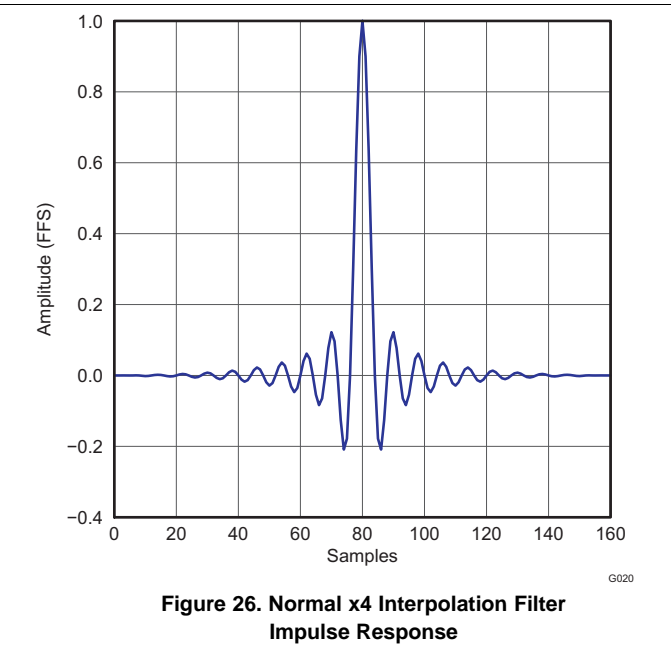
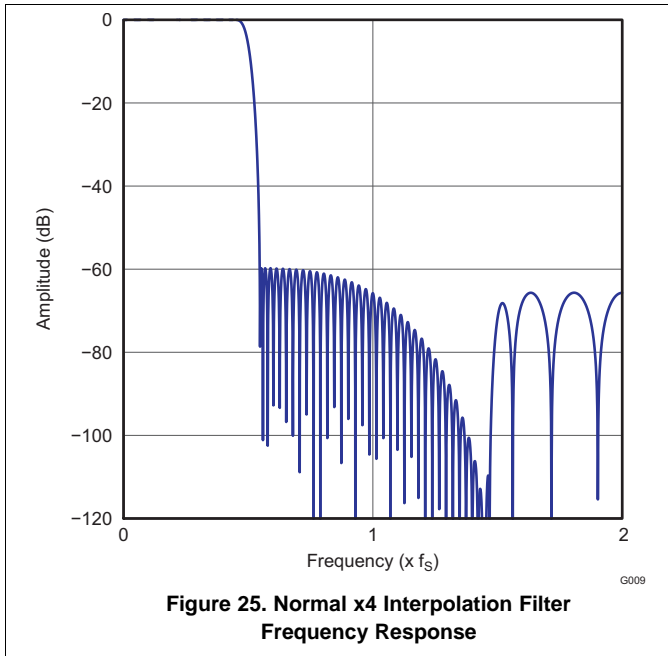
PARAMETER	CONDITION	VALUE (TYP)	VALUE (MAX)	UNIT
Filter Gain Pass Band	0 ..... $0.45 \times f_s$		$\pm 0.01$	dB
Filter Gain Stop Band	$0.55 \times f_s$ ..... $7.455 \times f_s$	-60		dB
Filter Group Delay		$20 / f_s$		S





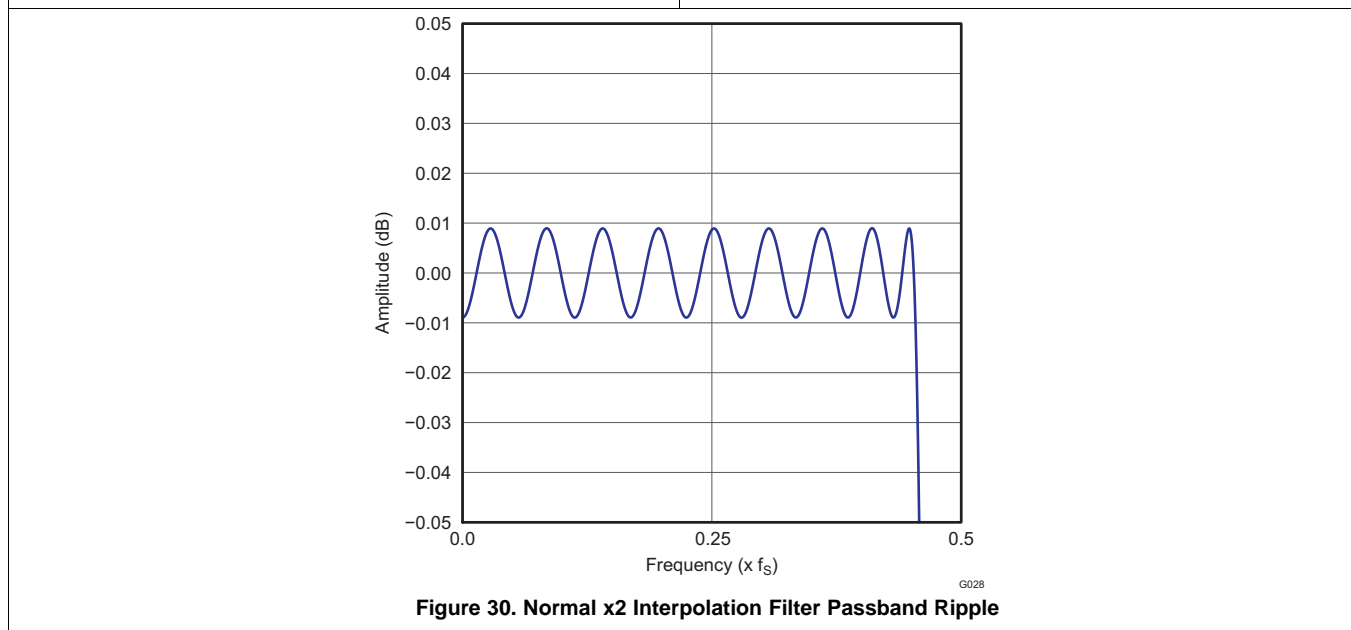
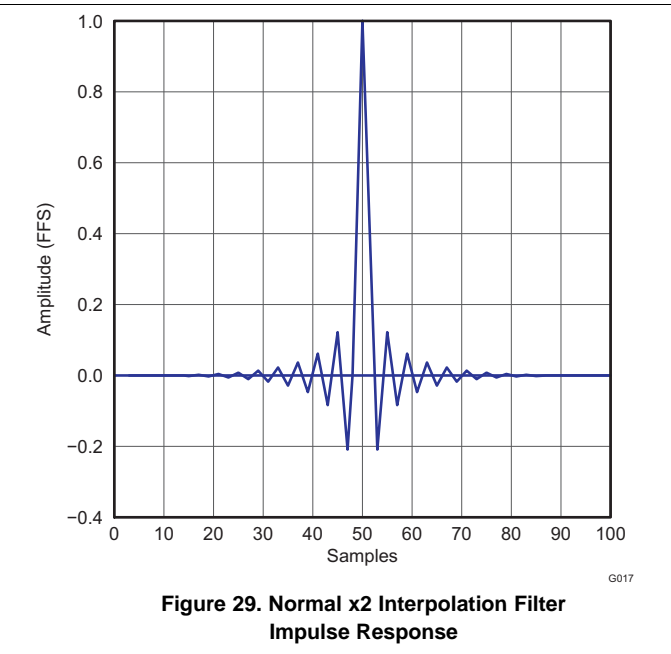
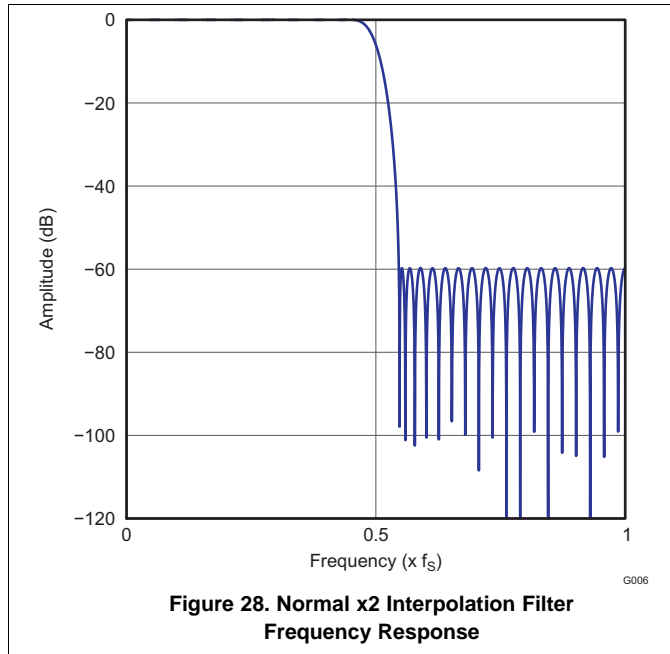
**Table 10. Normal x4 Interpolation Filter, Dual Rate**

PARAMETER	CONDITION	VALUE (TYP)	VALUE (MAX)	UNIT
Filter Gain Pass Band	0 ..... 0.45 × f <sub>S</sub>		±0.01	dB
Filter Gain Stop Band	0.55 × f <sub>S</sub> ..... 3.455 × f <sub>S</sub>	-60		dB
Filter Group Delay		20 / f <sub>S</sub>		S



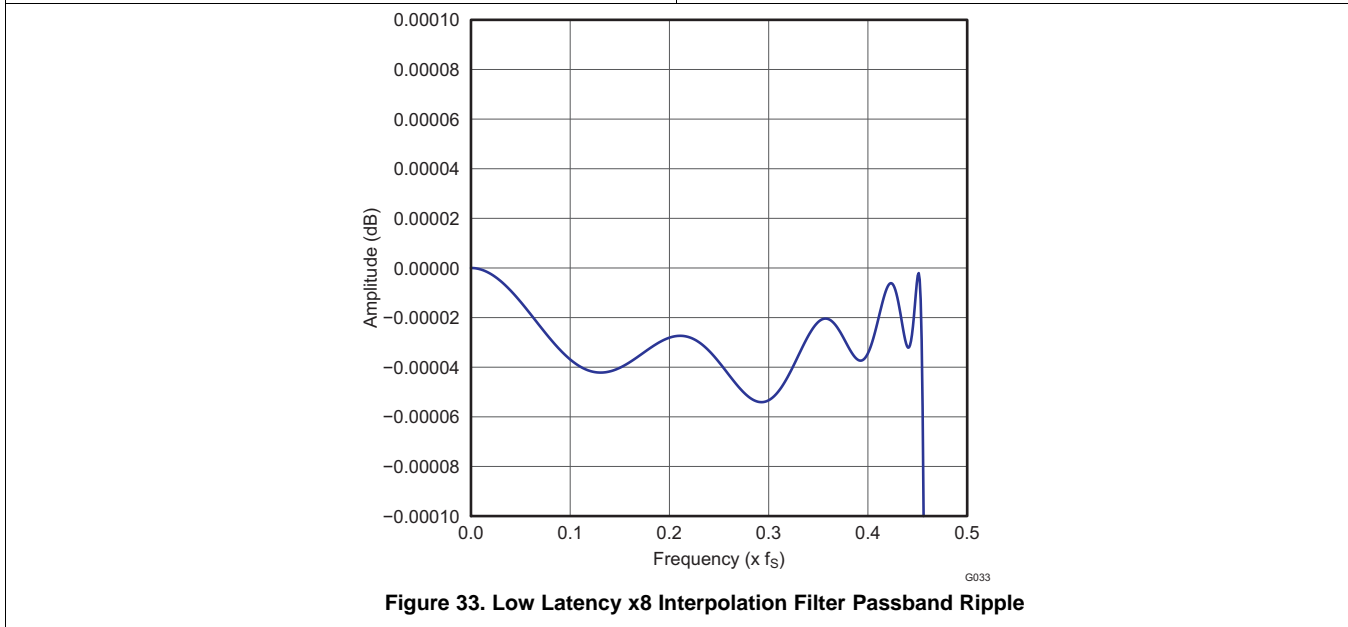
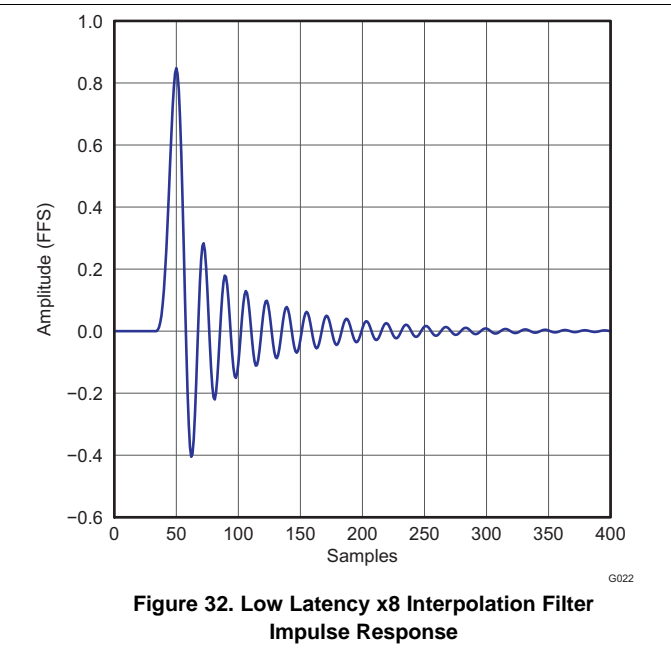
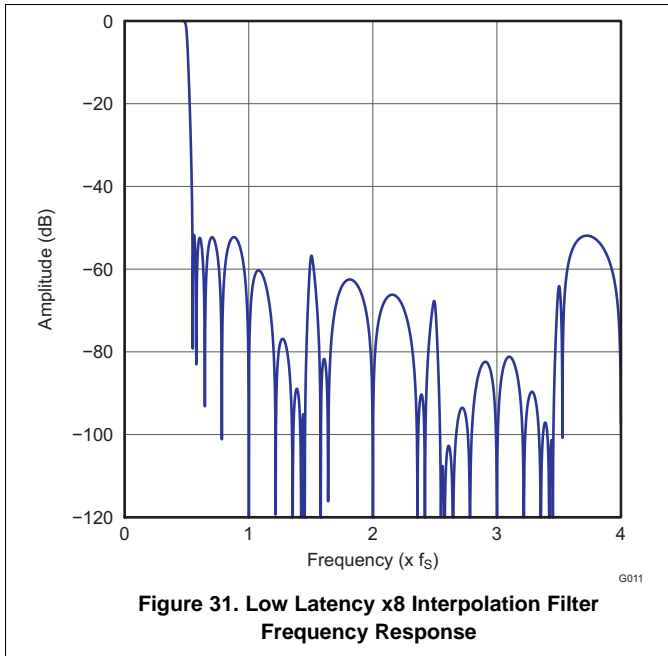
**Table 11. Normal x2 Interpolation Filter, Quad Rate**

PARAMETER	CONDITION	VALUE (TYP)	VALUE (MAX)	UNIT
Filter Gain Pass Band	0 ..... 0.45 × $f_s$		±0.01	dB
Filter Gain Stop Band	0.55 × $f_s$ ..... 1.455 × $f_s$	-60		dB
Filter Group Delay		20 / $f_s$		S



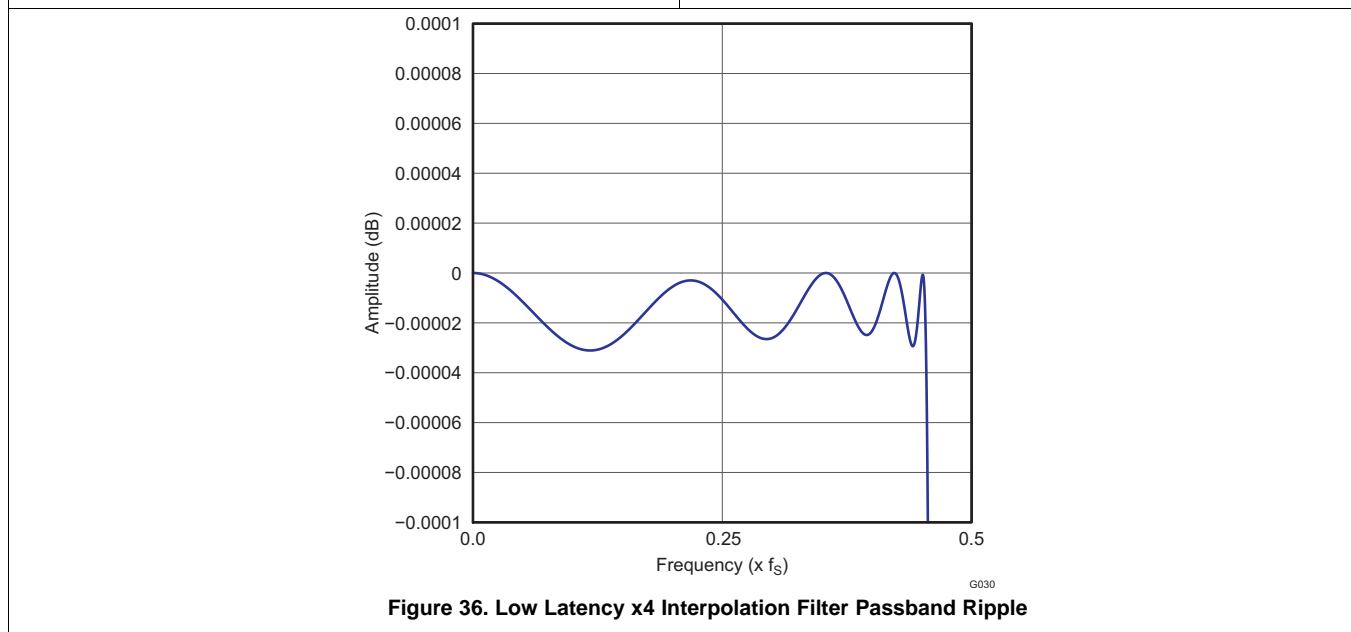
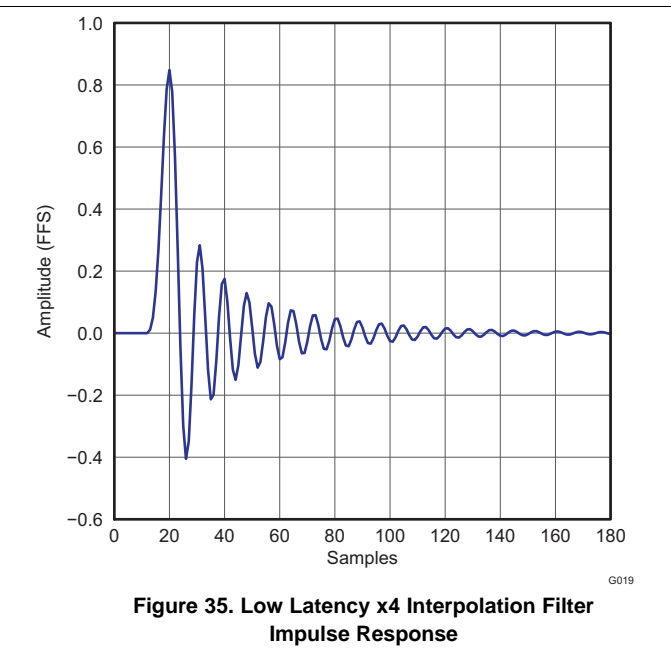
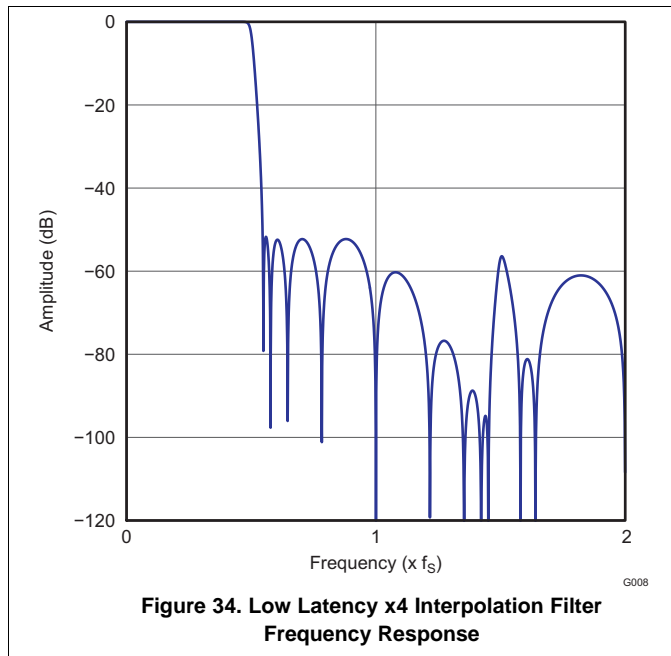
**Table 12. Low Latency x8 Interpolation Filter, Single Rate**

PARAMETER	CONDITION	VALUE (TYP)	VALUE (MAX)	UNIT
Filter Gain Pass Band	0 ..... 0.45 × f <sub>S</sub>		±0.001	dB
Filter Gain Stop Band	0.55 × f <sub>S</sub> ..... 7.455 × f <sub>S</sub>	-52		dB
Filter Group Delay		3.5 × t <sub>S</sub>		S



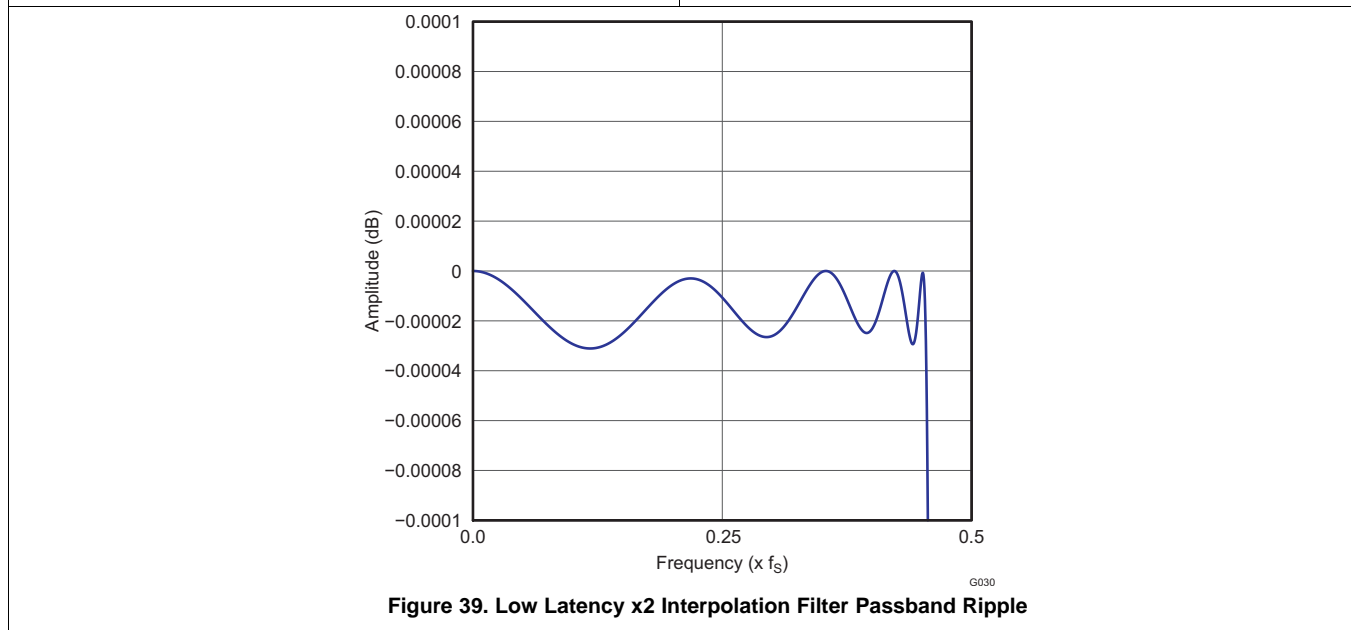
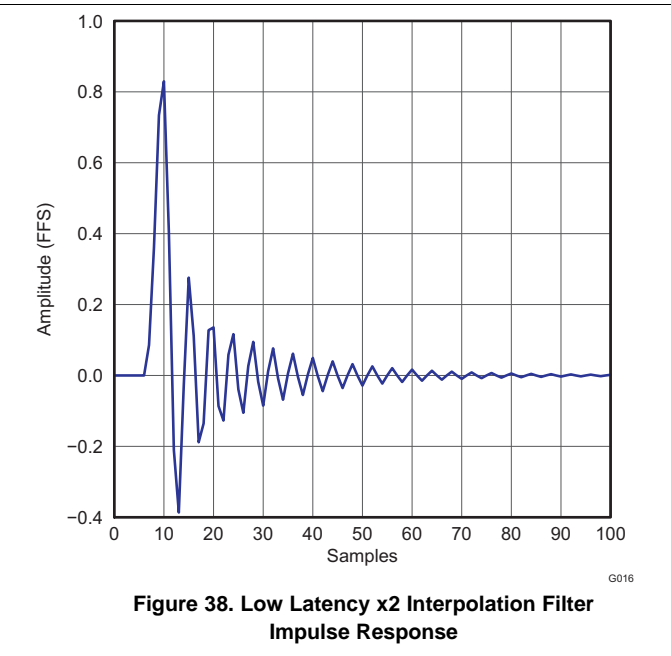
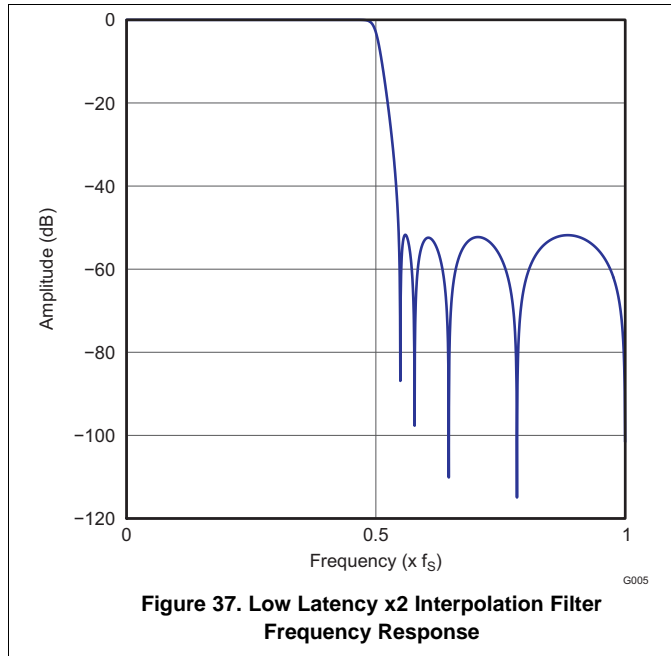
**Table 13. Low Latency x4 Interpolation Filter, Dual Rate**

PARAMETER	CONDITION	VALUE (TYP)	VALUE (MAX)	UNIT
Filter Gain Pass Band	0 ..... 0.45 × f <sub>S</sub>		±0.001	dB
Filter Gain Stop Band	0.55 × f <sub>S</sub> ..... 3.455 × f <sub>S</sub>	-52		dB
Filter Group Delay		3.5 × t <sub>S</sub>		S



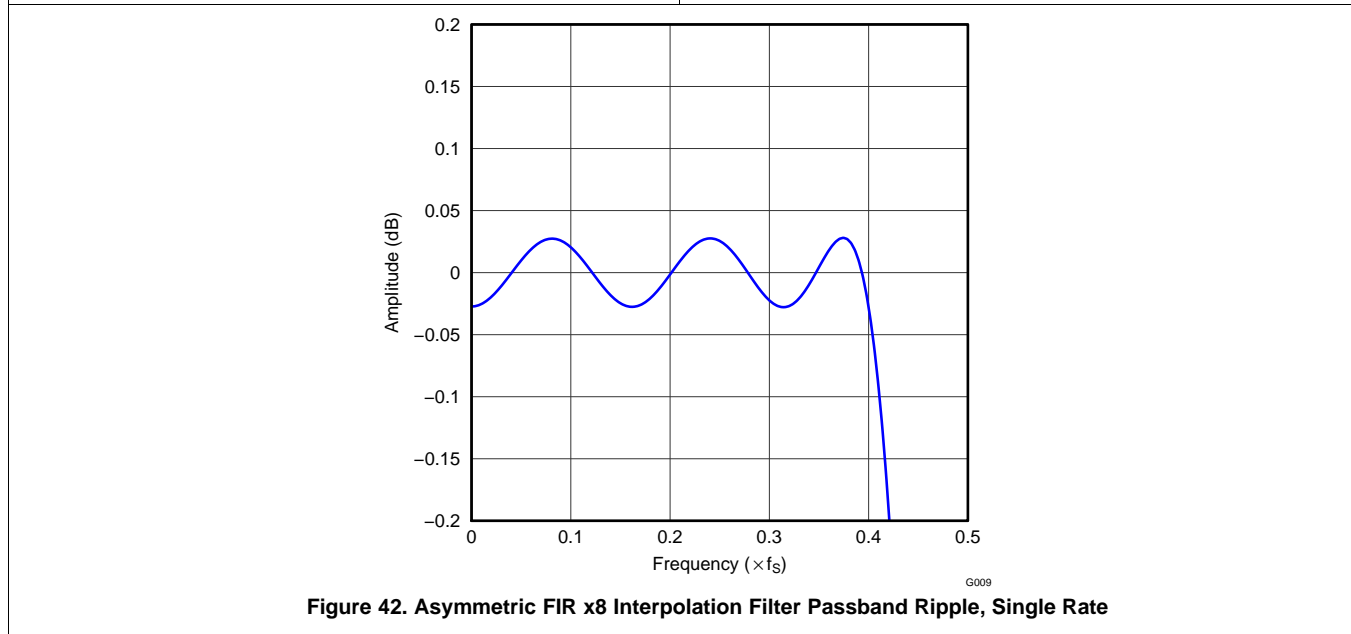
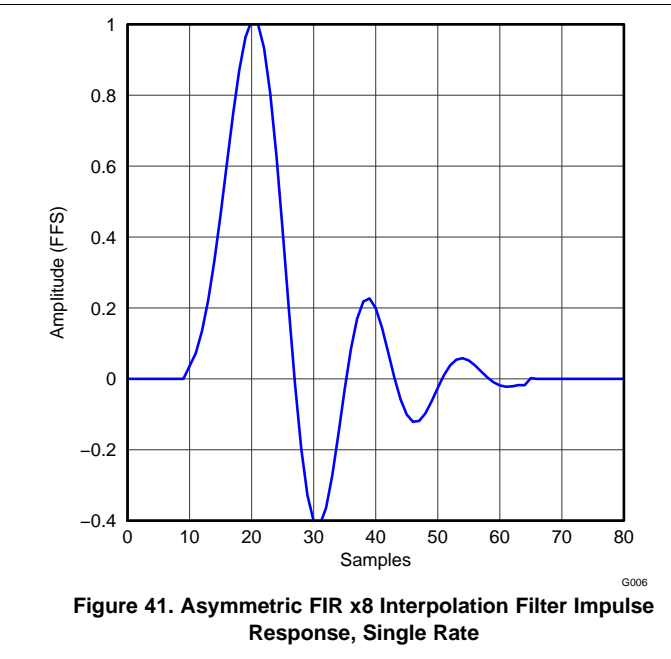
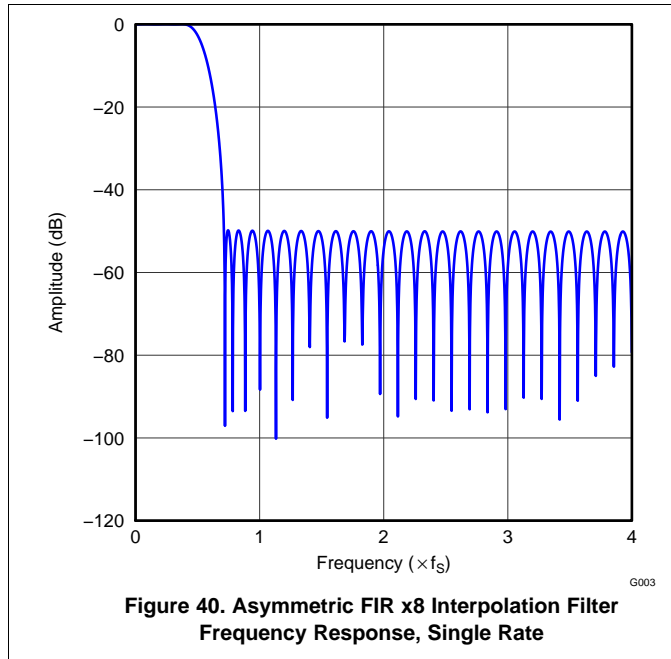
**Table 14. Low Latency x2 Interpolation Filter, Quad Rate**

PARAMETER	CONDITION	VALUE (TYP)	VALUE (MAX)	UNIT
Filter Gain Pass Band	0 ..... 0.45 × f <sub>S</sub>		±0.001	dB
Filter Gain Stop Band	0.55 × f <sub>S</sub> ..... 1.455 × f <sub>S</sub>	-52		dB
Filter Group Delay		3.5 × t <sub>S</sub>		S



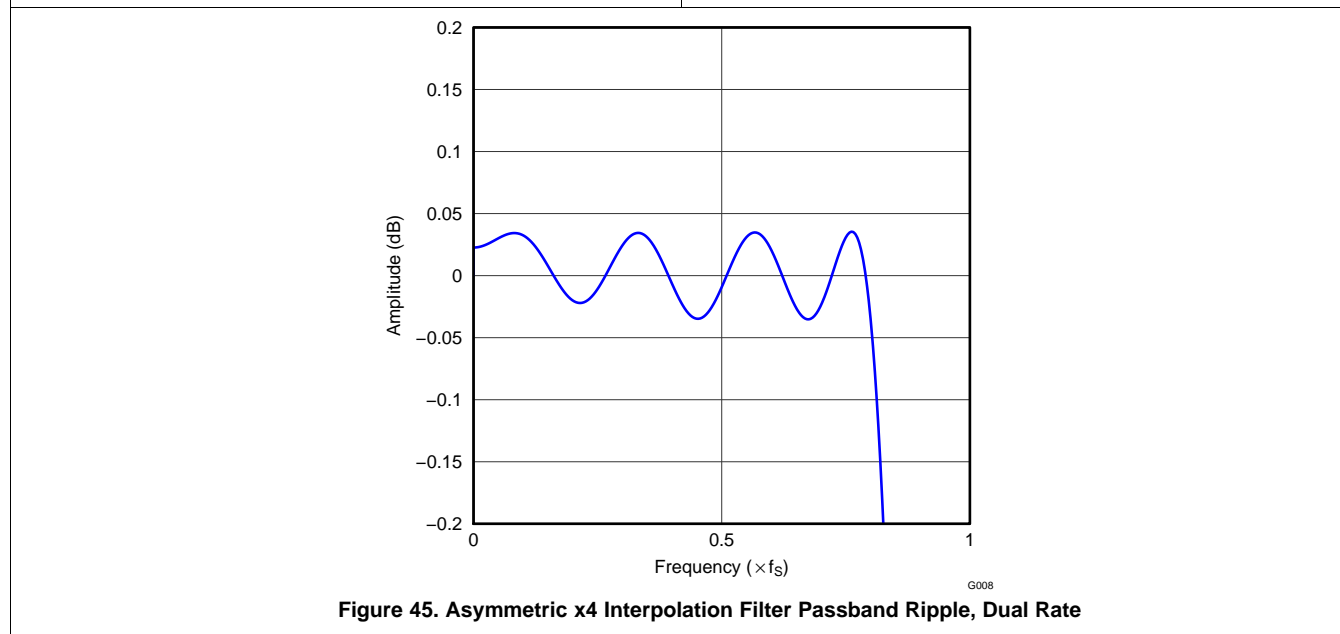
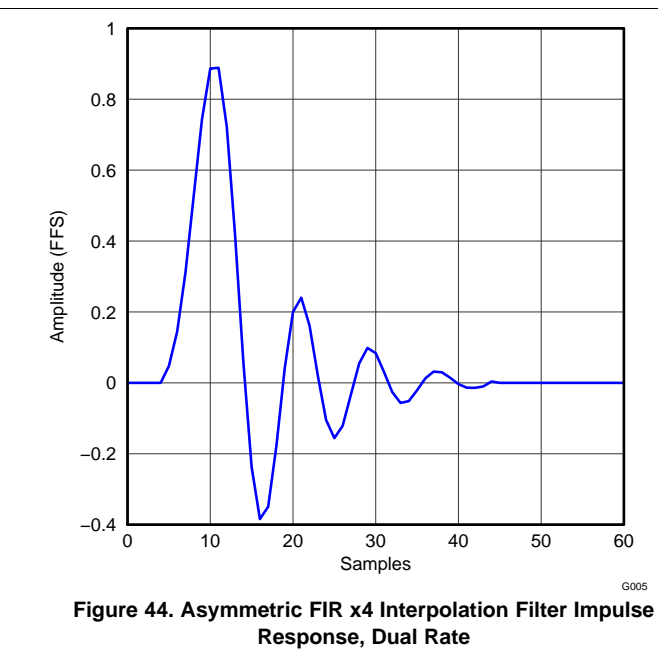
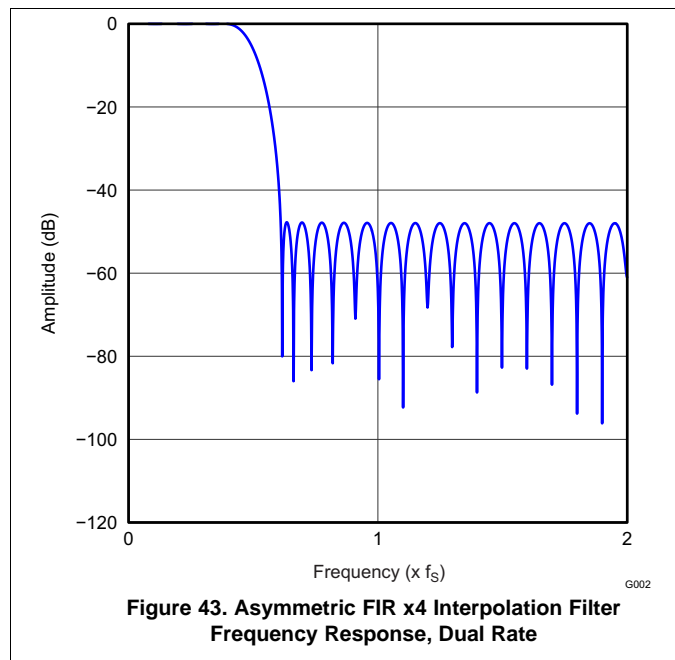
**Table 15. Asymmetric FIR x8 Interpolation Filter, Single Rate**

PARAMETER	CONDITION	VALUE (TYP)	VALUE (MAX)	UNIT
Filter Gain Pass Band	0 ..... 0.40 × f <sub>S</sub>		±0.05	dB
Filter Gain Stop Band	0.72 × f <sub>S</sub> ..... 7.28 × f <sub>S</sub>	-50		dB
Filter Group Delay		1.2 × t <sub>S</sub>		S



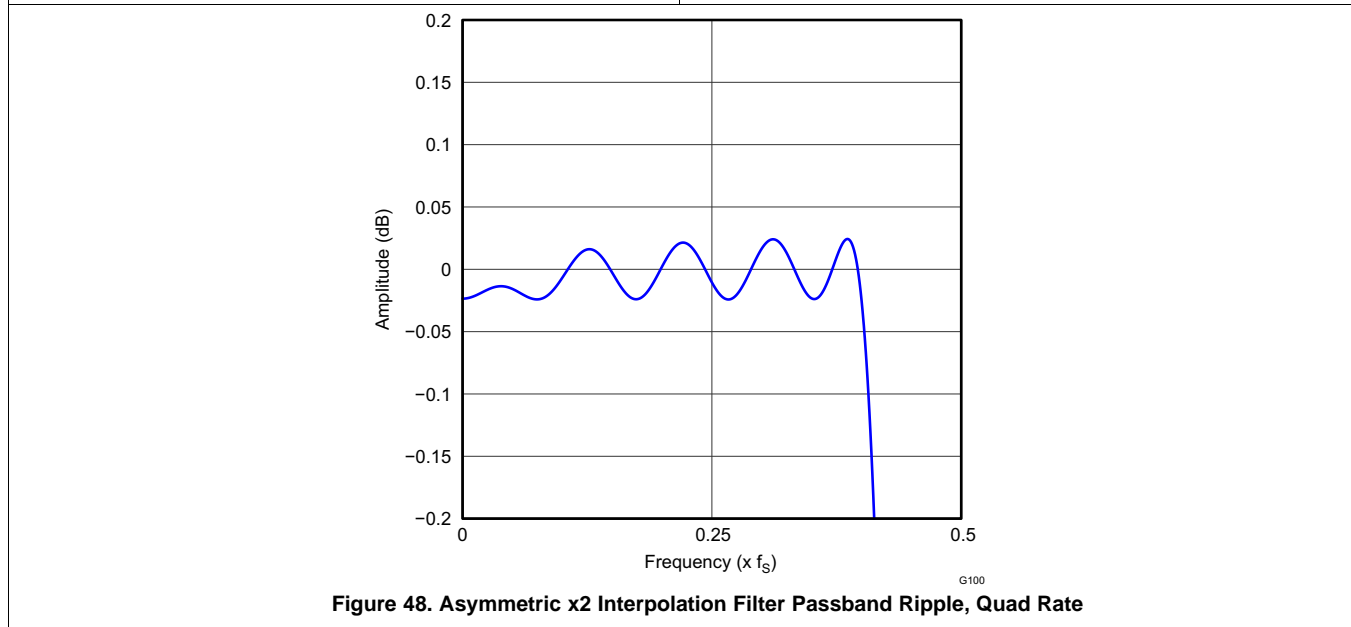
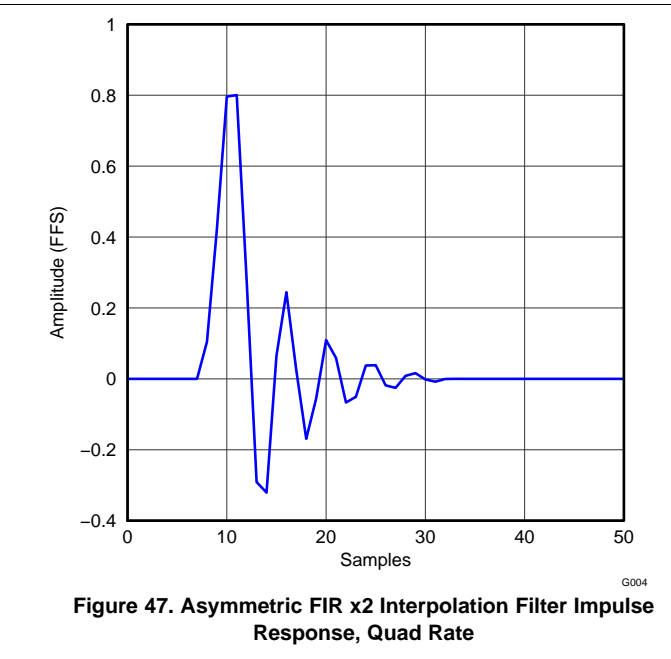
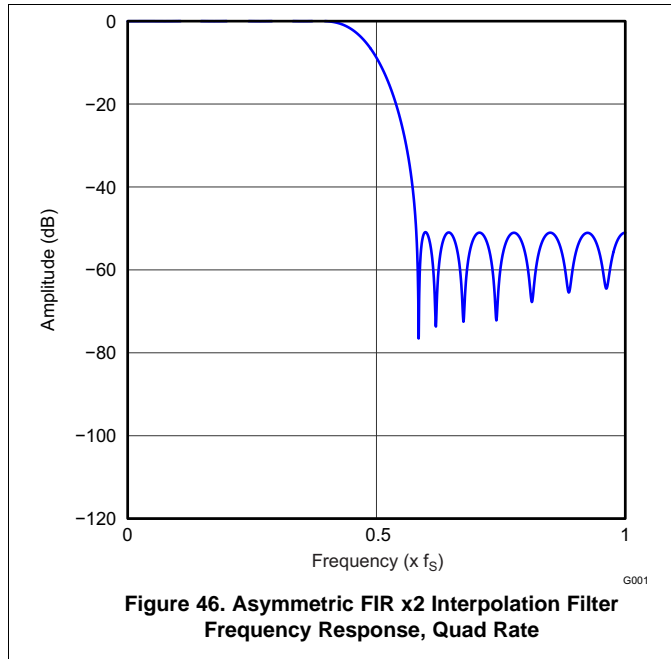
**Table 16. Asymmetric FIR x4 Interpolation Filter, Dual Rate**

PARAMETER	CONDITION	VALUE (TYP)	VALUE (MAX)	UNIT
Filter Gain Pass Band	0 ..... 0.40 × f <sub>S</sub>		±0.05	dB
Filter Gain Stop Band	0.72 × f <sub>S</sub> ..... 3.28 × f <sub>S</sub>	-50		dB
Filter Group Delay		1.2 × t <sub>S</sub>		S



**Table 17. Asymmetric FIR x2 Interpolation Filter, Quad Rate**

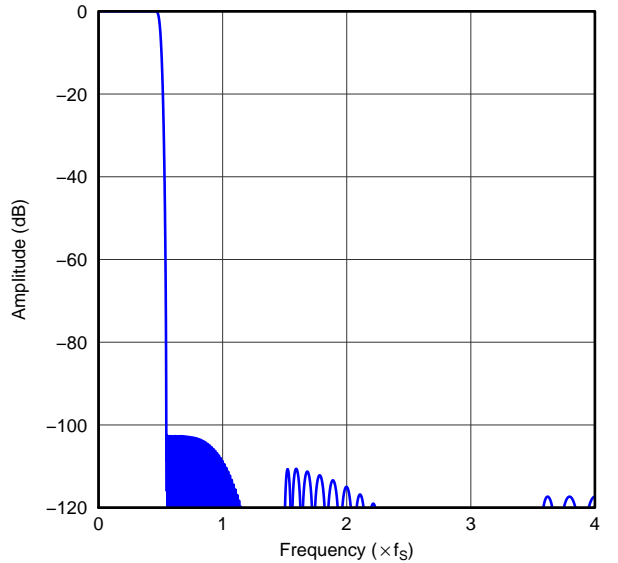
PARAMETER	CONDITION	VALUE (TYP)	VALUE (MAX)	UNIT
Filter Gain Pass Band	0 ..... 0.40 × f <sub>S</sub>		±0.05	dB
Filter Gain Stop Band	0.72 × f <sub>S</sub> ..... 1.28 × f <sub>S</sub>	-50		dB
Filter Group Delay		1.2 × t <sub>S</sub>		S



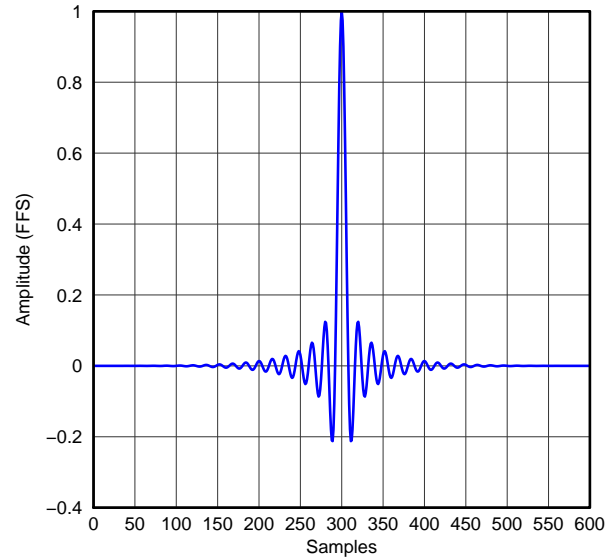


**Table 18. High-Attenuation x8 Interpolation Filter, Single Rate**

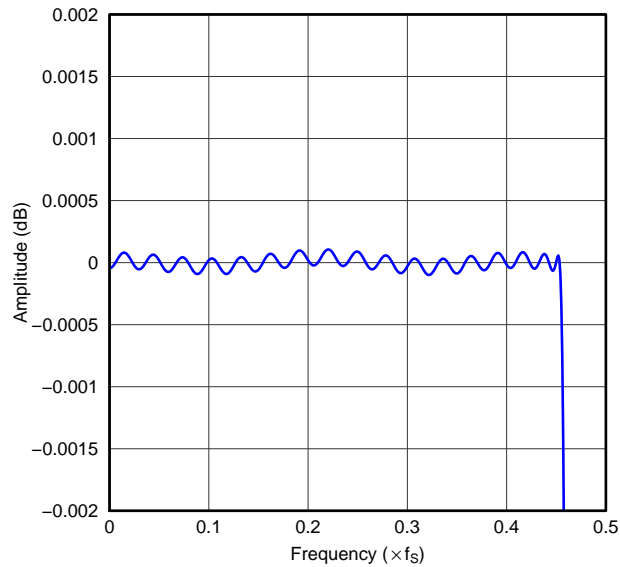
PARAMETER	CONDITION	VALUE (TYP)	VALUE (MAX)	UNIT
Filter Gain Pass Band	0 ..... 0.45 × f <sub>S</sub>		±0.0005	dB
Filter Gain Stop Band	0.55 × f <sub>S</sub> ..... 7.455 × f <sub>S</sub>	-100		dB
Filter Group Delay		33.7 × f <sub>S</sub>		S



**Figure 49. High-Attenuation x8 Interpolation Filter Frequency Response, Single Rate**



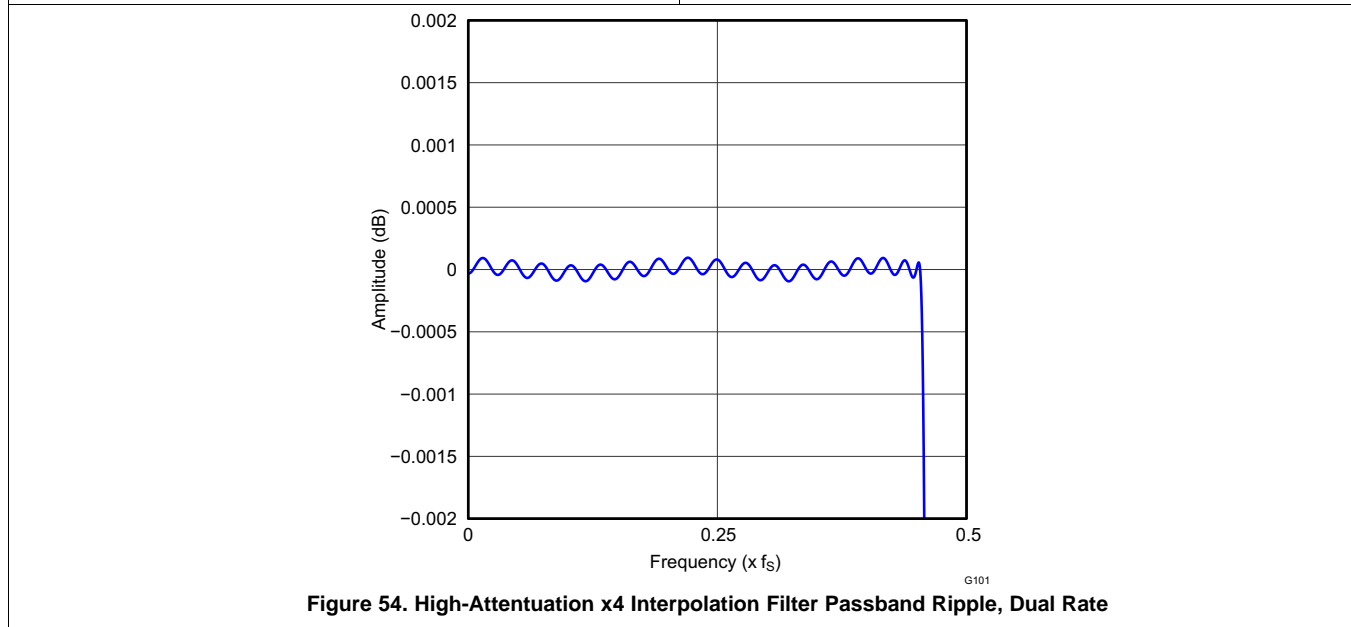
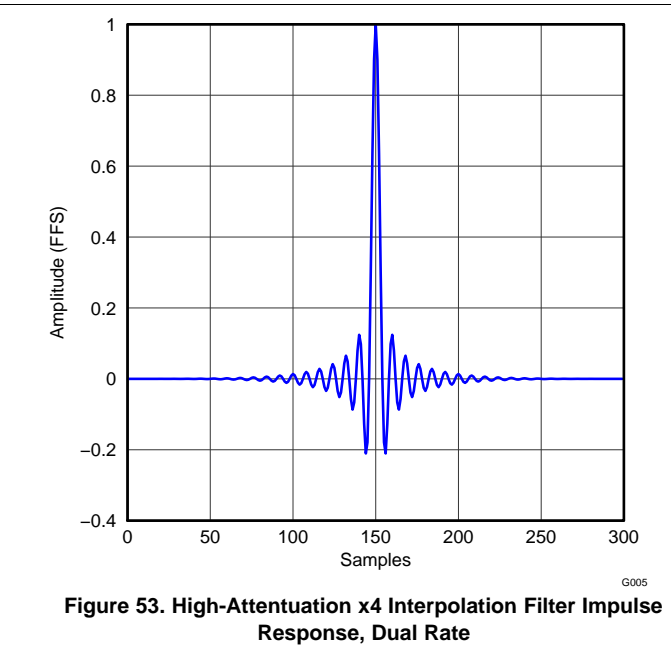
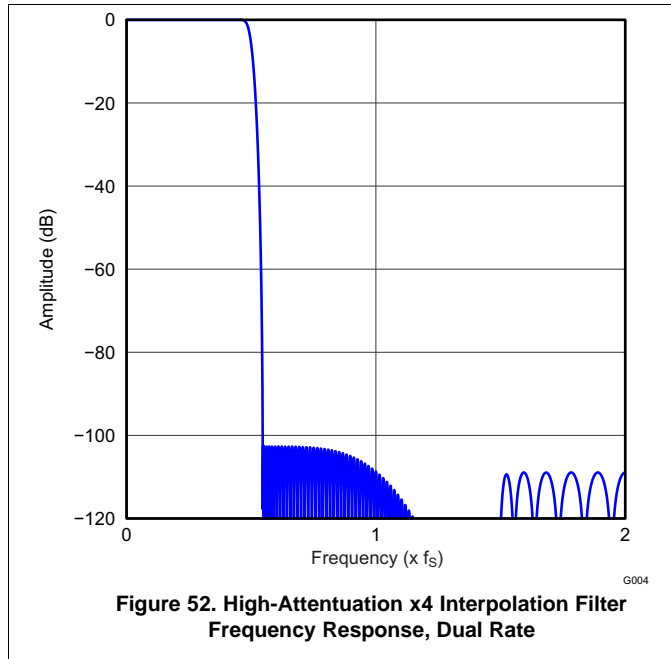
**Figure 50. High-Attenuation x8 Interpolation Filter Impulse Response, Single Rate**



**Figure 51. High-Attenuation x8 Interpolation Filter Passband Ripple, Single Rate**

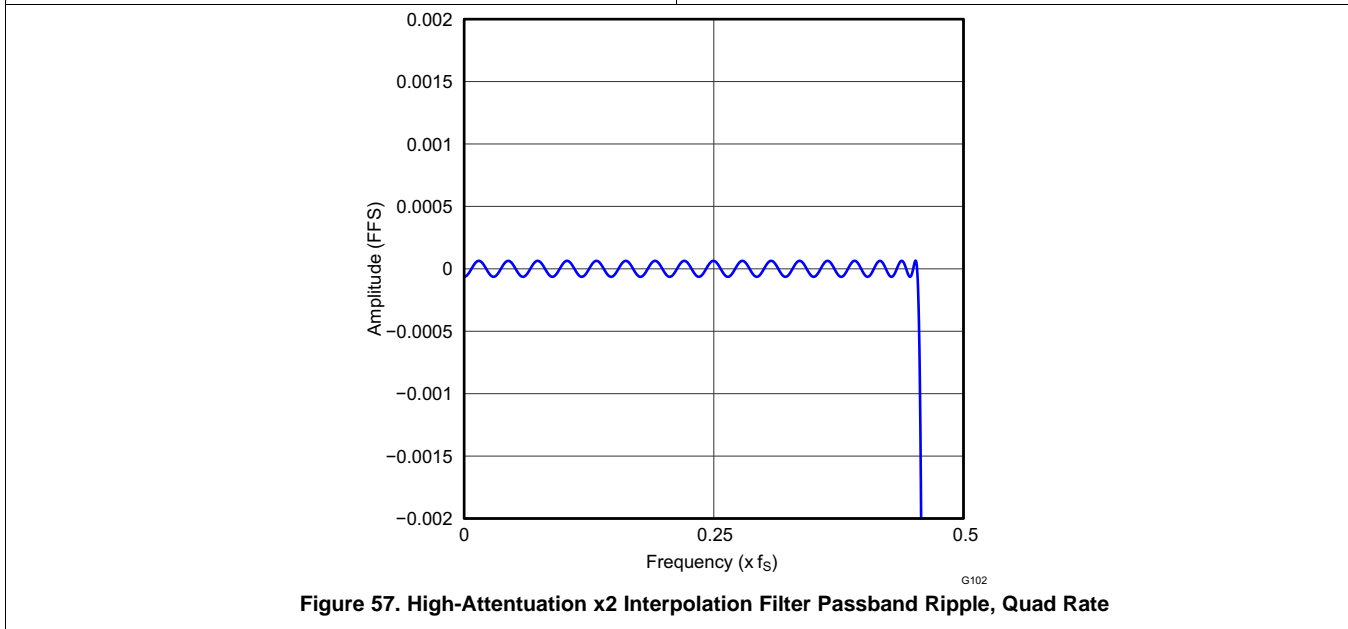
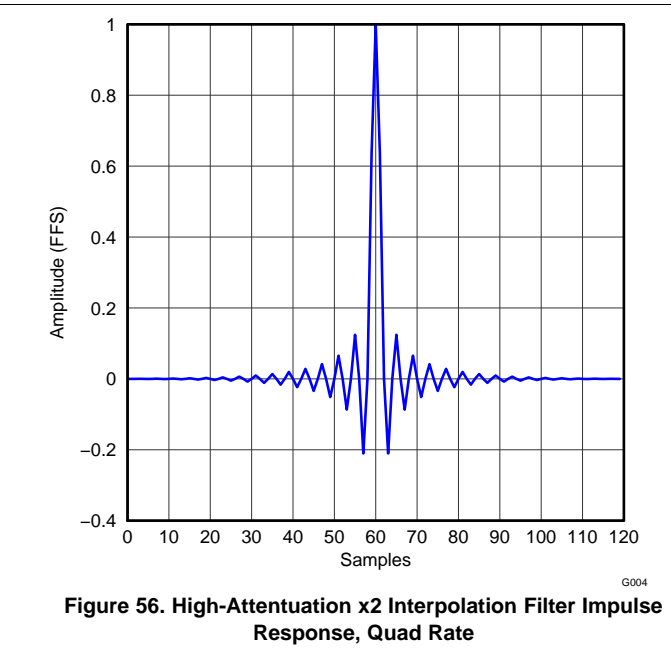
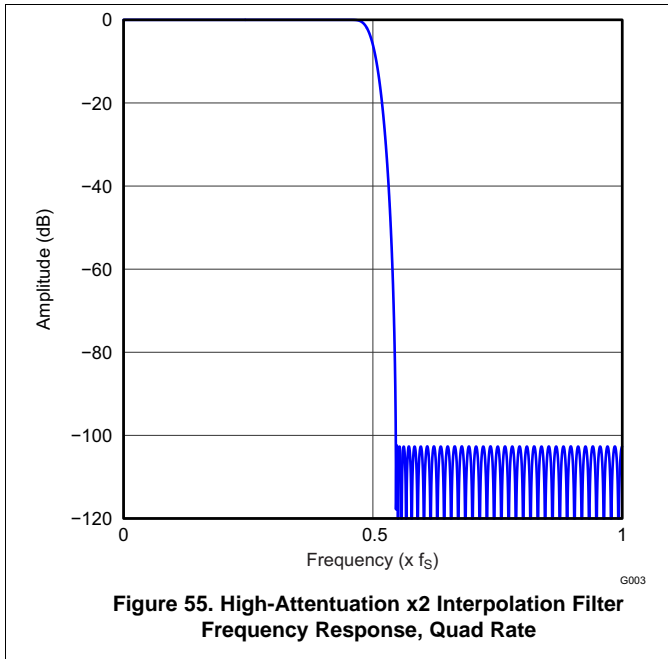
**Table 19. High-Attenuation x4 Interpolation Filter, Dual Rate**

PARAMETER	CONDITION	VALUE (TYP)	VALUE (MAX)	UNIT
Filter Gain Pass Band	0 ..... 0.45 × f <sub>S</sub>		±0.0005	dB
Filter Gain Stop Band	0.55 × f <sub>S</sub> ..... 3.455 × f <sub>S</sub>	-100		dB
Filter Group Delay		33.7 × t <sub>S</sub>		S



**Table 20. High-Attenuation x2 Interpolation Filter, Quad Rate**

PARAMETER	CONDITION	VALUE (TYP)	VALUE (MAX)	UNIT
Filter Gain Pass Band	0 ..... 0.45 × f <sub>S</sub>		±0.0005	dB
Filter Gain Stop Band	0.55 × f <sub>S</sub> ..... 1.455 × f <sub>S</sub>	–100		dB
Filter Group Delay		33.7 × t <sub>S</sub>		S



### 8.3.4.3 Overview

The PCM5252 features a configurable miniDSP core. The algorithms for the miniDSP are loaded into the device after power up. The miniDSP has direct access to the digital stereo audio stream, offering the possibility for advanced DSP algorithms with very low group delay. The miniDSP can run up to 1024 instructions on every audio sample at a 48 kHz sample rate.

The PCM5252 Smart Amplifier uses a mix of code sources. ROM based process flow and RAM based process flow. In the program, different algorithms are called from ROM – such as EQ, DRC and Zero Crossing volume control enabling a faster program load.

### 8.3.4.4 Smart SOA

The "Safe Operating Area" (SOA) for a loudspeaker is based on its electro-mechanical-thermal model. Depending on a speaker's inefficiency, some of the power is dissipated as heat rather than mechanical/acoustic energy. By understanding the characteristics of the speaker, Smart Amp is able to drive the speaker harder, without causing the speaker to thermally overload; or, suffer voice coil over-excitation and fail. SMART SOA are parameters that are differentiated by a PPC GUI into coefficients that the algorithm uses.

### 8.3.4.5 Smart BASS

Smart Bass is an intelligent True Bass Alignment algorithm. Smart Bass uses the combination of the speaker model and a desired target response selected by the user to equalize the speaker in the bass region. This target response is critical for the sound character and the user can apply the same target response to very different speakers and get the same sound.

In conventional adaptive Bass Boost Algorithms, designers need to vary the amount of bass boost whenever the output volume is changed. This approach is very much an "open loop" process. Smart Bass is a new proprietary algorithm that combines: True bass extension (in bandwidth and amplitude) and Psycho-acoustic bass extension, with a smart adaptive control.

Smart Bass varies the mix of True Bass extension and Psycho-acoustic bass extension in real time, depending on the loudspeakers position in its SOA.

Smart Bass dynamically switches between True Bass and Psycho-acoustic extension based on a number of parameters such as:

- Capabilities and properties of the speaker, including Q compensation
- Music type
- Volume setting
- Temperature
- User preferences
- Designer preferences

### 8.3.4.6 Smart Protection

The two main failure mechanisms for loudspeakers are over temperature and over excursion. By modeling the current state of the speaker, Smart Protection adaptively changes various settings in Smart Amplifier to avoid over temperature and over excursion. Design engineers must first provide details of the loudspeaker (driver and enclosure) into the GUI. From there the appropriate coefficients are generated for the algorithm.

### 8.3.4.7 Implementing a Real World Design

Traditionally, system developers and hardware engineers use graphic equalizers in trial-and-error fashion to boost the bass for each new speaker until the sound is right (or "good enough" in many cases). However, this typically results in a strange combined response with too much phase shift. This process must be repeated every time a new speaker is selected. The Smart Bass concept uses the GUI to select a desired target response takes the speaker out of the equation. By this approach users can obtain a target response with minimum phase warp and time domain ringing which gives a speedy and tight bass. Conversely, users can select a target response that has lots of ringing to give a classical heavy 'oomph' bass.

### 8.3.4.8 Digital Output

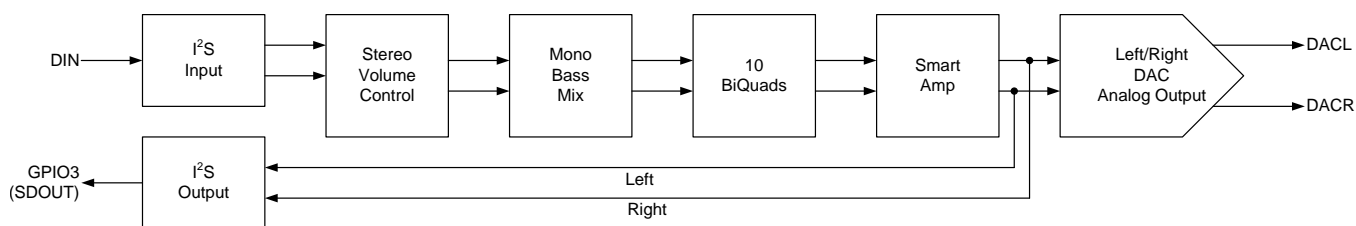
The PCM5252 supports an SDOOUT output. This can be selected within the process flow, and driven out of a GPIO pin selected in the register map (e.g. Page 0 / Register 80). The I2S output can be fed back to the signal host and used for echo cancellation.

### 8.3.4.9 Software

Software selection for the PCM5252 is supported through TI's comprehensive PurePath™ Console Development Environment; a powerful, easy-to-use tool designed specifically to simplify development on the PCM5252 platform. Visit the PCM5252 product folder on [www.ti.com](http://www.ti.com) to learn more about PurePath™ Console and the latest status on available, ready-to-use DSP algorithms.

### 8.3.4.10 Process Flow

An example of the default Process Flow available for the PCM5252 in the PurePath™ Console target is shown below:



**Figure 58. Example Processflow**

This process flow has from input to output:

- Volume block, from -110 db to +6 dB with 0.5 dB steps, including a fixed gain block of 0dB to 12 dB gain
- monobass mixer – mixes the bass into mono below the set frequency, useful for systems where left and right speaker shares the same cabinet volume, bypassed when not needed
- 10 Biquads for filtering and EQ. The PPC GUI have an advanced biquad control where various filter and eq options can be set and controlled.
- SmartAmp block, containing all the blocks for bass Q compensation, bass alignment, excursion control and power limited
- Digital monitor output enabled on GPIO3

### 8.3.5 DAC and Differential Analog Outputs

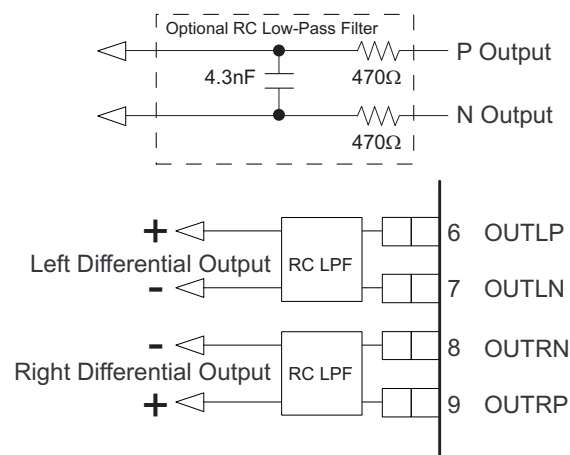
#### 8.3.5.1 Analog Outputs

The PCM5252 devices include a two-channel DAC, with differential outputs. Each pin has a full-scale output voltage is  $2.1 V_{rms}$  with ground center output. This equates to a  $4.2 V_{rms}$  differential output. A DC-coupled load is supported in addition to an AC-coupled load, if the load resistance conforms to the specification. The PCM5252 DAC outputs on the OUTLP, OUTLN, OUTRP, and OUTRN terminals have market-leading low out-of-band noise, which offer up to 20-dB lower out-of-band noise compared with existing DAC technology.

Many applications require an external low-pass RC filter ( $470 \Omega + 1.2 \text{ nF}$ ) to provide sufficient out-of-band noise rejection. This RC filter provides the added advantage of improved protection against ESD damage.

The PCM5252 can also support single ended outputs, using OUTLP and OUTRP respectively. A single  $470\text{-}\Omega$  and  $2.2\text{-nF}$  capacitor can be used on each pin in single ended mode.

The choice between VREF and VCOM modes affects the maximum output level. This is explained in [Recommended Operating Conditions](#).



**Figure 59. Optional Low Pass Filters**

#### 8.3.5.2 Choosing Between VREF and VCOM Modes

VREF mode is the default configuration. This mode allows full  $2.1\text{-}V_{rms}$  signal output. As shown in [Recommended Operating Conditions](#), the minimum AVDD to avoid clipping is  $3.2 \text{ V}$ .

VCOM mode allows setting a custom common-mode voltage when required by the application. This somewhat limits the output signal swing before clipping.

##### 8.3.5.2.1 Voltage Reference and Output Levels

The PCM5252 devices have an internal, fixed band-gap reference voltage, with default operation in VREF mode. No external decoupling capacitor is required for this mode.

The PCM5252 devices can be operated with a common-mode voltage output (VCOM mode) at the VCOM pin by setting Page 1, Register 1, D(0) to 1. In this mode, an external decoupling capacitor is required.

When using this DAC in VREF mode, the output-signal voltage is independent of the power-supply voltage: The D/A conversion gain in VREF mode yields a  $2.1\text{-}V_{rms}$  output voltage with a digital full-scale input. However, in VREF mode, an output waveform may clip due to the limitations that may be present in the analog power supply voltage. On the other hand, the full-scale output voltage in VCOM mode is proportional to the analog power supply AVDD (for example,  $(2.1 \times AVDD / 3.3) V_{rms}$ ).

### 8.3.5.2.2 Mode Switching Sequence, from VREF Mode to VCOM Mode

Following register setting sequence is recommended for changing VREF mode to VCOM mode.

- |                        |   |
|------------------------|---|
| 1. Page 0 / Register 2 | RQST = 1: Standby mode                        |
| 2. Page 1 / Register 8 | RCMF = 1: Fast ramp up → on                   |
| 3. Page 1 / Register 9 | VCPD = 0: VCOM is power on                    |
| 4.                     | Wait 3 ms with external capacitor = 1 $\mu$ F |
| 5. Page 1 / Register 8 | RCMF = 0: Fast ramp up → off                  |
| 6. Page 1 / Register 1 | OSEL = 1: VCOM mode                           |
| 7. Page 0 / Register 2 | RQST = 0: Normal mode                         |

### 8.3.5.3 Digital Volume Control

A basic digital volume control with range from 24 dB to –103 dB and mute is available on each channels by Page 0, Register 61, D(7:0) for L-ch and Register 62, D(7:0) for R-ch. These volume controls all have 0.5-dB step programmability over most gain and attenuation ranges. [Table 21](#) lists the detailed gain versus programmed setting for this basic volume control. Volume can be changed for both L-ch and R-ch at the same time or independently by Page 0, Register 60, D(1:0). When D(1:0) set 00 (default), independent control is selected. When D(1:0) set 01, R-ch accords with L-ch volume. When D(1:0) set 10, L-ch accords with R-ch volume. To set D(1:0) to 11 is prohibited.

#### NOTE

This volume control is done externally to the miniDSP and only influences the analog DAC output. Any changes to the SDOOUT data should be done in the miniDSP process flow.

**Table 21. Digital Volume Control Settings**

GAIN SETTING	BINARY DATA	GAIN (dB)	COMMENTS
0	0000-0000	24.0	Positive maximum
1	0000-0001	23.5	
:	:	—	
46	0010-1110	1.0	
47	0010-1111	0.5	
48	0011-0000	0.0	No attenuation (default)
49	0011-0001	–0.5	
50	0011-0010	–1.0	
51	0011-0011	–1.5	
:	:	—	
253	1111-1101	–102.5	
254	1111-1110	–103	Negative maximum
255	1111-1111	– $\infty$	Negative infinite (Mute)

Ramp-up frequency and ramp-down frequency can be controlled by Page 0, Register 63, D(7:6) and D(3:2) as shown in [Table 22](#). Also Ramp-up step and ramp-down step can be controlled by Page 0, Register 63 D(5:4) and D(1:0) as shown in [Table 23](#).

**Table 22. Ramp-Up or Down Frequency**

RAMP-UP SPEED	EVERY N $f_s$	COMMENTS	RAMP-DOWN FREQUENCY	EVERY N $f_s$	COMMENTS
00	1	Default	00	1	Default
01	2		01	2	
10	4		10	4	
11	Direct change		11	Direct change	

**Table 23. Ramp-Up or Down Step**

RAMP-UP STEP	STEP dB	COMMENTS	RAMP-DOWN STEP	STEP dB	COMMENTS
00	4.0		00	-4.0	
01	2.0		01	-2.0	
10	1.0	Default	10	-1.0	Default
11	0.5		11	-0.5	

#### 8.3.5.3.1 Emergency Ramp-Down

Digital volume emergency ramp-down by is provided for situations such as I<sup>2</sup>S clock error and power supply failure. Ramp-down speed is controlled by Page 0, Register 64, D(7:6). Ramp-down step can be controlled by Page 0 Register 64, D(5:4). Default is ramp-down by every  $f_s$  cycle with  $-4$ -dB step.

#### 8.3.5.4 Analog Gain Control

Analog gain control can be selected between  $2-V_{rms}$  FS (0 dB) or  $1-V_{rms}$  FS ( $-6$  dB). Gain is controlled through hardware by the AGNS pin, and through software (SPI/I<sup>2</sup>C), Page 1, Register 2, D4(L-ch) / D0(R-ch).



### 8.3.6 Reset and System Clock Functions

#### 8.3.6.1 Clocking Overview

The PCM5252 devices have flexible systems for clocking. Internally, the device requires a number of clocks, mostly at related clock rates to function correctly. All of these clocks can be derived from the serial audio interface in one form or another.

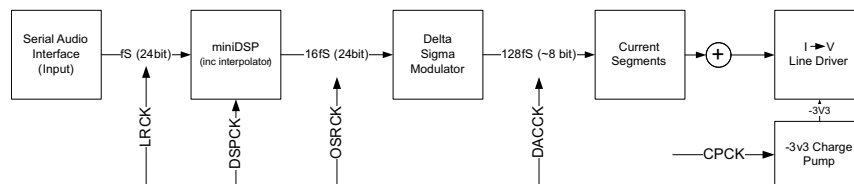


Figure 60. Audio Flow with Respective Clocks

As shown in Figure 60 the data flows at the sample rate ( $f_s$ ). Once the data is brought into the serial audio interface, it gets processed, interpolated and modulated all the way to  $128 \times f_s$  before arriving at the current segments for the final digital to analog conversion.

The clock tree is shown in Figure 61.

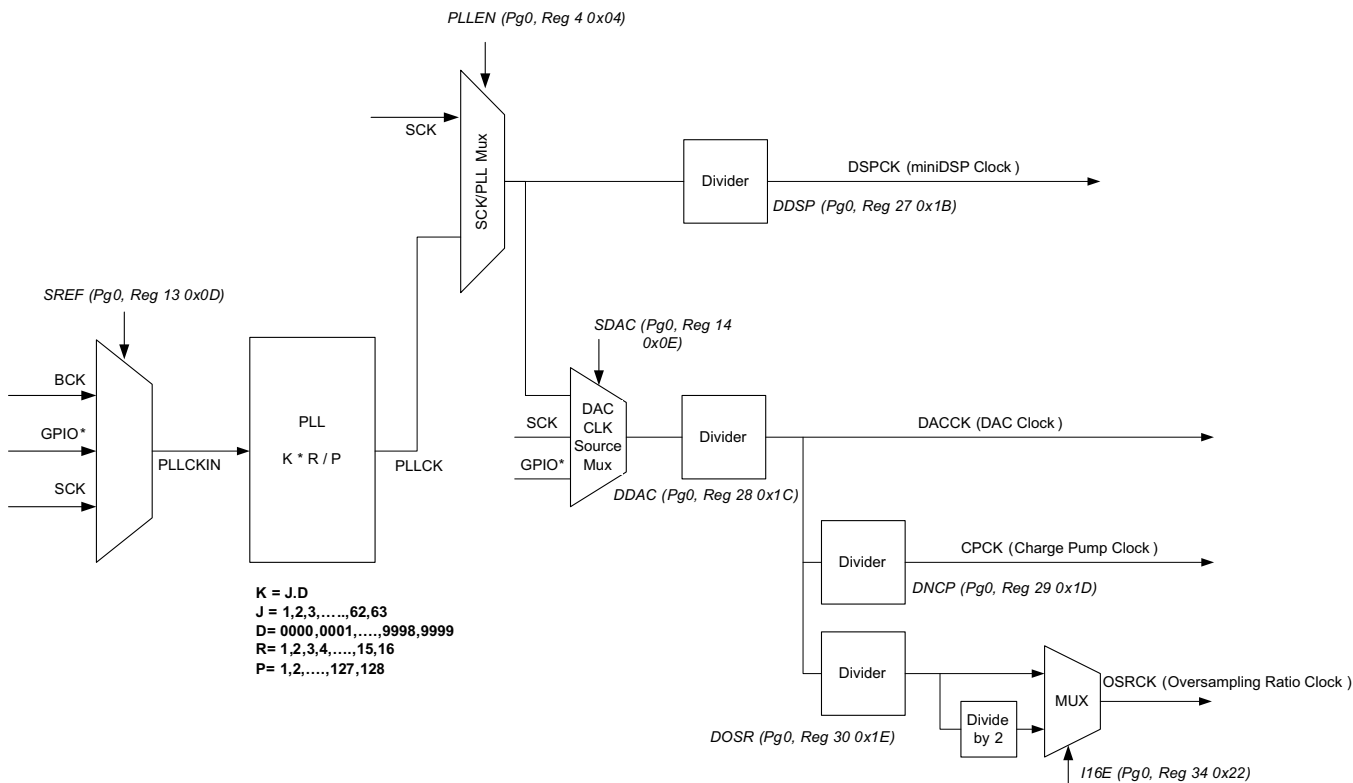


Figure 61. PCM5252 Clock Distribution Tree

The serial audio interface typically has 4 connections: SCK (system master clock), BCK (bit clock), LRCK (left right word clock), and DIN (data). The device has an internal PLL that is used to take either SCK or BCK and create the higher rate clocks required by the interpolating processor and the DAC clock. This allows the device to operate with or without an external SCK.

In situations where the highest audio performance is required, it is suggested that the SCK is brought to the device, along with BCK and LRCK. The device should be configured so that the PLL is only providing a clock source to the miniDSP. By ensuring that the DACCK (DAC Clock) is being driven by the external SCK source, jitter evident in the PLL (in all PLLs) is kept out of the DAC, charge pump, and oversampling system.

Everything else should be a division of the incoming SCK. This is done by setting DAC CLK Source Mux (SDAC in [Figure 61](#)) to use SCK as a source, rather than the output of the SCK/PLL Mux. Code examples for this are available in [SLASE12](#).

When the Auto Clock Configuration bit is set (Page 0/ Register 0x25), no additional clocks configuration is required. However, when setting custom PLL values and so forth, the target output rates should match those shown in the recommended PLL values of [Table 122](#).

### 8.3.6.2 Clock Slave Mode With Master and System Clock (SCK) Input (4 Wire $\dot{P}$ S)

The PCM5252 requires a system clock to operate the digital interpolation filters and advanced segment DAC modulators. The system clock is applied at the SCK input and supports up to 50 MHz. The PCM5252 system-clock detection circuit automatically senses the system-clock frequency. Common audio sampling frequencies in the bands of 8 kHz, 16 kHz, (32 kHz - 44.1 kHz - 48 kHz), (88.2kHz - 96kHz), (176.4 kHz - 192 kHz), and 384 kHz with  $\pm 4\%$  tolerance are supported. Values in the parentheses are grouped when detected, (for example, 88.2 kHz and 96 kHz are detected as *double rate*, and 32 kHz, 44.1 kHz and 48 kHz are detected as *single rate*.)

In the presence of a valid bit SCK, BCK and LRCK in software mode, the device will auto-configure the clock tree and PLL to drive the miniDSP as required.

The sampling frequency detector sets the clock for the digital filter, Delta Sigma Modulator (DSM) and the Negative Charge Pump (NCP) automatically. [Table 24](#) shows examples of system clock frequencies for common audio sampling rates.

SCK rates that are not common to standard audio clocks, between 1 MHz and 50 MHz, are only supported in software mode by configuring various PLL and clock-divider registers. This programmability allows the device to become a clock master and drive the host serial port with LRCK and BCK, from a non-audio related clock (for example, using 12 MHz to generate 44.1 kHz [LRCK] and 2.8224 MHz [BCK]).

**Table 24. System Master Clock Inputs for Audio Related Clocks**

SAMPLING FREQUENCY	SYSTEM CLOCK FREQUENCY ( $f_{SCK}$ ) (MHz)											
	64 $f_s$	128 $f_s$	192 $f_s$	256 $f_s$	384 $f_s$	512 $f_s$	768 $f_s$	1024 $f_s$	1152 $f_s$	1536 $f_s$	2048 $f_s$	3072 $f_s$
8 kHz	– <sup>(1)</sup>	1.024 <sup>(2)</sup>	1.536 <sup>(2)</sup>	2.048	3.072	4.096	6.144	8.192	9.216	12.288	16.384	24.576
16 kHz	– <sup>(1)</sup>	2.048 <sup>(2)</sup>	3.072 <sup>(2)</sup>	4.096	6.144	8.192	12.288	16.384	18.432	24.576	36.864	49.152
32 kHz	– <sup>(1)</sup>	4.096 <sup>(2)</sup>	6.144 <sup>(2)</sup>	8.192	12.288	16.384	24.576	32.768	36.864	49.152	– <sup>(1)</sup>	– <sup>(1)</sup>
44.1 kHz	– <sup>(1)</sup>	5.6488 <sup>(2)</sup>	8.4672 <sup>(2)</sup>	11.2896	16.9344	22.5792	33.8688	45.1584	– <sup>(1)</sup>	– <sup>(1)</sup>	– <sup>(1)</sup>	– <sup>(1)</sup>
48 kHz	– <sup>(1)</sup>	6.144 <sup>(2)</sup>	9.216 <sup>(2)</sup>	12.288	18.432	24.576	36.864	49.152	– <sup>(1)</sup>	– <sup>(1)</sup>	– <sup>(1)</sup>	– <sup>(1)</sup>
88.2 kHz	– <sup>(1)</sup>	11.2896 <sup>(2)</sup>	16.9344	22.5792	33.8688	45.1584	– <sup>(1)</sup>	– <sup>(1)</sup>	– <sup>(1)</sup>	– <sup>(1)</sup>	– <sup>(1)</sup>	– <sup>(1)</sup>
96 kHz	– <sup>(1)</sup>	12.288 <sup>(2)</sup>	18.432	24.576	36.864	49.152	– <sup>(1)</sup>	– <sup>(1)</sup>	– <sup>(1)</sup>	– <sup>(1)</sup>	– <sup>(1)</sup>	– <sup>(1)</sup>
176.4 kHz	– <sup>(1)</sup>	22.579	33.8688	45.1584	– <sup>(1)</sup>	– <sup>(1)</sup>	– <sup>(1)</sup>	– <sup>(1)</sup>	– <sup>(1)</sup>	– <sup>(1)</sup>	– <sup>(1)</sup>	– <sup>(1)</sup>
192 kHz	– <sup>(1)</sup>	24.576	36.864	49.152	– <sup>(1)</sup>	– <sup>(1)</sup>	– <sup>(1)</sup>	– <sup>(1)</sup>	– <sup>(1)</sup>	– <sup>(1)</sup>	– <sup>(1)</sup>	– <sup>(1)</sup>
384 kHz	24.576	49.152	– <sup>(1)</sup>	– <sup>(1)</sup>	– <sup>(1)</sup>	– <sup>(1)</sup>	– <sup>(1)</sup>	– <sup>(1)</sup>	– <sup>(1)</sup>	– <sup>(1)</sup>	– <sup>(1)</sup>	– <sup>(1)</sup>

(1) This system clock rate is not supported for the given sampling frequency.

(2) This system clock rate is supported by PLL mode.

See [Timing Requirements: PCM Audio Data](#) for clock timing requirements.

### 8.3.6.3 Clock Slave Mode With BCK PLL to Generate Internal Clocks (3-Wire PCM)

The system clock PLL mode allows designers to use a simple 3-wire I<sup>2</sup>S audio source. The 3-wire source reduces the need for a high frequency SCK, making PCB layout easier, and reduces high frequency electromagnetic interference.

In hardwired mode, the internal PLL is disabled as soon as an external SCK is supplied.

In hardwired mode, the device starts up expecting an external SCK input, but if BCK and LRCK start correctly while SCK remains at ground level for 16 successive LRCK periods, then the internal PLL starts, automatically generating an internal SCK from the BCK reference. Specific BCK rates are required to generate an appropriate master clock. [Table 25](#) describes the minimum and maximum BCK per LRCK for the integrated PLL to automatically generate an internal SCK.

In software mode, the user must set all the PLL registers and clock divider registers for referencing BCK. See [Clock Generation Using the PLL](#) for more information. Recommended values can be found in [Table 122](#).

**Table 25. BCK Rates (MHz) by LRCK Sample Rate for PCM5252 PLL Operation**

SAMPLE F (kHz)	BCK (f <sub>s</sub> )	
	32	64
8	–	–
16	–	1.024
32	1.024	2.048
44.1	1.4112	2.8224
48	1.536	3.072
96	3.072	6.144
192	6.144	12.288
384	12.288	24.576

### 8.3.6.4 Clock Generation Using the PLL

The PCM5252 supports a wide range of options to generate the required clocks for the DAC section as well as interface and other control blocks as shown in [Figure 61](#).

The clocks for the PLL require a source reference clock. This clock is sourced as the incoming BCK or SCK. In software mode, a GPIO can also be used.

The source reference clock for the PLL reference clock is selected by programming the SRCREF value on Page 0, Register 13, D(6:4). The PCM5252 provides several programmable clock dividers to achieve a variety of sampling rates for the DAC and clocks for the NCP, OSR and the miniDSP. OSRCK for OSR must be set at 16 f<sub>s</sub> frequency by DOSR on Page0, Register 30, D(6:0). See [Figure 61](#).

If PLL functionality is not required, set the PLEN value on Page 0, Register 4, D(0) to 0. In this situation, an external SCK is required.

**Table 26. PLL Configuration Registers**

CLOCK MULTIPLEXER	FUNCTION	BITS
SRCREF	PLL reference	Page 0, Register 13, D(6:4)
DIVIDER	FUNCTION	BITS
DDSP	miniDSP clock divider	Page 0, Register 27, D(6:0)
DACCK	DAC clock divider	Page 0, Register 28, D(6:0)
CPCCK	NCP clock divider	Page 0, Register 29, D(6:0)
OSRCK	OSR clock divider	Page 0, Register 30, D(6:0)
DBCK	External BCK Div	Page 0, Register 32, D(6:0)
DLRK	External LRCK Div	Page 0, Register 33, D(7:0)

### 8.3.6.5 PLL Calculation

The PCM5252 has an on-chip PLL with fractional multiplication to generate the clock frequency needed by the audio DAC, Negative Charge Pump, Modulator and Digital Signal Processing blocks. The programmability of the PLL allows operation from a wide variety of clocks that may be available in the system. The PLL input (PLLCKIN) supports clock frequencies from 1 MHz to 50 MHz and is register programmable to enable generation of required sampling rates with fine precision.

The PLL is enabled by default. The PLL can be turned on by writing to Page 0, Register 4, D(0). When the PLL is enabled, the PLL output clock PLLCK is given by [Equation 1](#).

$$\text{PLLCK} = \frac{\text{PLLCKIN} \times \text{R} \times \text{J.D}}{\text{P}} \quad \text{or} \quad \text{PLLCK} = \frac{\text{PLLCKIN} \times \text{R} \times \text{K}}{\text{P}}$$

where

- R = 1, 2, 3,4, ... , 15, 16
  - J = 4,5,6, . . . 63, and D = 0000, 0001, 0002, . . . 9999
  - K = [J value].[D value]
  - P = 1, 2, 3, ... 15
- (1)

R, J, D, and P are programmable. J is the integer portion of K (the numbers to the left of the decimal point), while D is the fractional portion of K (the numbers to the right of the decimal point, assuming four digits of precision).

#### 8.3.6.5.1 Examples:

- If K = 8.5, then J = 8, D = 5000
- If K = 7.12, then J = 7, D = 1200
- If K = 14.03, then J = 14, D = 0300
- If K = 6.0004, then J = 6, D = 0004

When the PLL is enabled and D = 0000, the following conditions must be satisfied:

- 1 MHz ≤ ( PLLCKIN / P ) ≤ 20 MHz
- 64 MHz ≤ (PLLCKIN x K x R / P ) ≤ 100 MHz (in VREF mode)
- 72 MHz ≤ (PLLCKIN x K x R / P ) ≤ 86 MHz (in VCOM mode)
- 1 ≤ J ≤ 63

When the PLL is enabled and D ≠ 0000, the following conditions must be satisfied:

- 6.667 MHz ≤ PLLCKIN / P ≤ 20 MHz
- 64 MHz ≤ (PLLCKIN x K x R / P ) ≤ 100 MHz (in VREF mode)
- 72 MHz ≤ (PLLCKIN x K x R / P ) ≤ 86 MHz (in VCOM mode)
- 4 ≤ J ≤ 11
- R = 1

When the PLL is enabled,

- $f_s = (\text{PLLCKIN} \times \text{K} \times \text{R}) / (2048 \times \text{P})$
- The value of N is selected so that  $f_s \times \text{N} = \text{PLLCKIN} \times \text{K} \times \text{R} / \text{P}$  is in the allowable range.

**Example:** MCLK = 12 MHz and  $f_s = 44.1$  kHz, (N=2048)

Select P = 1, R = 1, K = 7.5264, which results in J = 7, D = 5264

**Example:** MCLK = 12 MHz and  $f_s = 48.0$  kHz, (N=2048)

Select P = 1, R = 1, K = 8.192, which results in J = 8, D = 1920

Values are written to the registers in [Table 27](#).

### 8.3.6.5.1.1 Recommended PLL Settings

Recommended values for the PLL can be found after the register descriptions in this data sheet. Different values are defined based on the device configuration for VREF or VCOM mode.

Other configurations are possible, at your own risk.

Table 27 show the details of the register locations, as well as the nomenclature for the table of registers found at the end of this document.

**Table 27. PLL Registers**

DIVIDER	FUNCTION	BITS
PLLE	PLL enable	Page 0, Register 4, D(0)
PPDV	PLL P	Page 0, Register 20, D(3:0)
PJDV	PLL J	Page 0, Register 21, D(5:0)
PDDV	PLL D	Page 0, Register 22, D(5:0)
		Page 0, Register 23, D(7:0)
PRDV	PLL R	Page 0, Register 24, D(3:0)

**Table 28. PLL Configuration Recommendations**

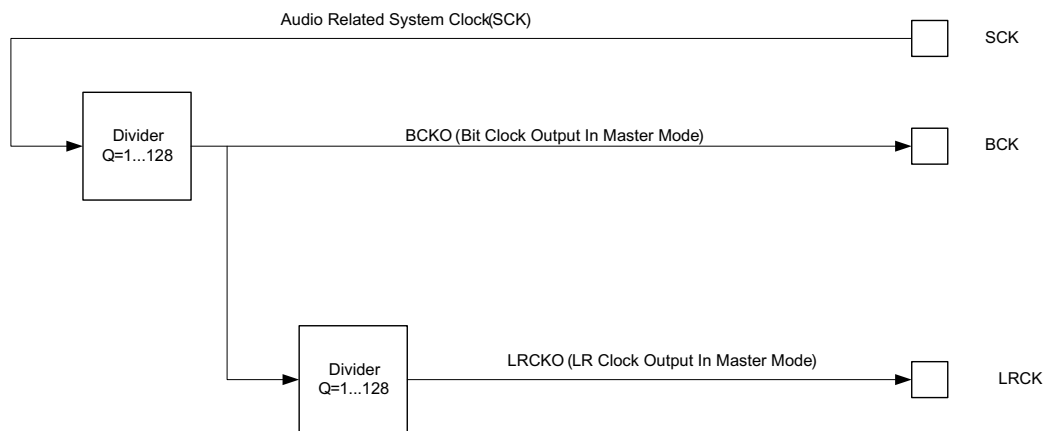
COLUMN	DESCRIPTION
$f_s$ (kHz)	Sampling frequency
RSCK	Ratio between sampling frequency and SCK frequency (SCK frequency = RSCK $\times$ sampling frequency)
SCK (MHz)	System master clock frequency at SCK input (pin 20)
PLL VCO (MHz)	PLL VCO frequency as PLLCK in <a href="#">Figure 61</a>
P	One of the PLL coefficients in <a href="#">Equation 1</a>
PLL REF (MHz)	Internal reference clock frequency which is produced by SCK / P
$M = K * R$	The final PLL multiplication factor computed from K and R as described in <a href="#">Equation 1</a>
$K = J.D$	One of the PLL coefficients in <a href="#">Equation 1</a>
R	One of the PLL coefficients in <a href="#">Equation 1</a>
PLL $f_s$	Ratio between $f_s$ and PLL VCO frequency (PLL VCO / $f_s$ )
DSP $f_s$	Ratio between miniDSP operating clock rate and $f_s$ (PLL $f_s$ / NMAC)
NMAC	The miniDSP clock divider value in <a href="#">Table 26</a>
DSP CLK (MHz)	The miniDSP operating frequency as DSPCK in <a href="#">Figure 61</a>
MOD $f_s$	Ratio between DAC operating clock frequency and $f_s$ (PLL $f_s$ / NDAC)
MOD f (kHz)	DAC operating frequency as DACCK in <a href="#">Figure 61</a>
NDAC	DAC clock divider value in <a href="#">Table 26</a>
DOSR	OSR clock divider value in <a href="#">Table 26</a> for generating OSRCK in <a href="#">Figure 61</a> . DOSR must be chosen so that MOD $f_s$ / DOSR = 16 for correct operation.
NCP	NCP (negative charge pump) clock divider value in <a href="#">Table 26</a>
CP f	Negative charge pump clock frequency ( $f_s \times \text{MOD } f_s / \text{NCP}$ )
% Error	Percentage of error between PLL VCO / PLL $f_s$ and $f_s$ (mismatch error). <ul style="list-style-type: none"> <li>This number is typically zero but can be non-zero especially when K is not an integer (D is not zero).</li> <li>This number may be non-zero only when the PCM5252 acts as a master.</li> </ul>

### 8.3.6.6 Clock Master Mode from Audio Rate Master Clock

In Master Mode, the device generates bit clock (BCK) and left-right clock (LRCK) and outputs them on the appropriate pins. To configure the device in this mode, first put the device into reset, then use registers BCKO and LRKO (Pg 0, Reg 9 0x09). Then reset the LRCK and BCK divider counters using bits RBCK and RLRK (Pg 0, Reg 12 0x0C). Finally, exit reset.

An example of this is given in register programming examples in the PCM5242 data sheet ([SLASE12](#).)

[Figure 62](#) shows a simplified serial port clock tree for the device in master mode.



**Figure 62. Simplified Clock Tree for SCK Sourced Master Mode**

In master mode, SCK is an input and BCK/LRCK are outputs. BCK and LRCK are integer divisions of SCK. Master mode with a non-audio rate master clock source will require external GPIOs to use the PLL in standalone mode.

The PLL will also need to be configured to ensure that the onchip miniDSP processor can be driven at its maximum clock rate.

Register changes that need to be done include switching the device into master mode, and setting the divider ratio.

Here is an example of using 24.576 MCLK as a master clock source and driving the BCK and LRCK with integer dividers to create 48 kHz.

In this mode, the DAC section of the device is also running from the PLL output. While the PLL inside the PCM5252 is one that has been specified to achieve the stated performance, using the SCK CMOS Oscillator source will have less jitter.

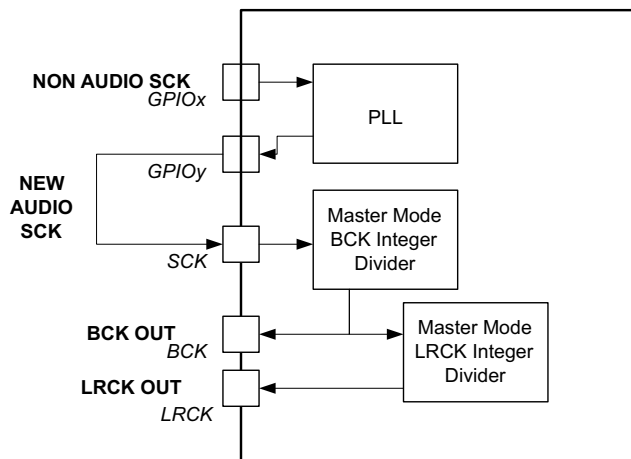
To switch the DAC clocks (SDAC in the [Figure 61](#)) the following registers should be modified.

- Clock Tree Flex Mode (Page 253, Registers 0x3F and 0x40)
- DAC and OSR Source Clock Register (Page 0, Reg 14) – set to 0x30 (SCK input, and OSR is set to whatever the DAC source is)
- The DAC clock divider should be  $16 F_S$ .
  - $16 \times 48 \text{ kHz} = 768 \text{ kHz}$
  - $24.576 \text{ MHz (SCK in)} / 768 \text{ kHz} = 32$
  - Therefore, divide ratio for register DDAC (Page 0, Reg 28 0x1C) should be set to 32. The may the register is mapped gives  $0x00 = 1$ , so 32 must be converted to 0x1F.

An example configuration can be found in the PCM5242 data sheet ([SLASE12](#)).

### 8.3.6.7 Clock Master from a Non-Audio Rate Master Clock

The classic example here is running a 12-MHz Master clock for a 48-kHz sampling system. Given the clock tree for the device (shown in Figure 61), a non-audio clock rate cannot be brought into the SCK to the PLL in master mode. Therefore, the PLL source must be configured to be a GPIO pin, and the output brought back into another GPIO pin.



**Figure 63. Application Diagram for Using Non-Audio Clock Sources to Generate Audio Clocks**

The clock flow through the system is shown in Figure 63. The newly-generated SCK must be brought out of the device on a GPIO pin, then brought into the SCK pin for integer division to create BCK and LRCK outputs.

**NOTE**

Pullup resistors must be used on BCK and LRCK in this mode to ensure the device does not go into sleep mode.

A code example for configuring this mode is provided in the PCM5242 data sheet ([SLASE12](#)).

## 8.4 Device Functional Modes

### 8.4.1 Choosing a Control Mode

**SPI** Mode is selected by connecting MODE1 to DVDD. SPI Mode uses four signal lines and allows higher-speed full-duplex communication between the host and the PCM5252 device.

**I<sup>2</sup>C** Mode is selected by connecting MODE1 to DGND and Mode2 to DVDD. I<sup>2</sup>C uses two signal lines for half-duplex communication, and is widely used in a variety of devices.

**Hardware** Control Mode is selected by connecting both MODE1 and MODE2 pins to DGND. Hardware control is useful in applications that do not require on-the-fly device-reconfiguration changes in operating features such as gain or filter latency selection.

See [Pin Assignments](#) for a comparison of pin assignments for the 32-pin VQFN.

#### 8.4.1.1 Software Control

##### 8.4.1.1.1 SPI Interface

The SPI interface is a 4-wire synchronous serial port which operates asynchronously to the serial audio interface and the system clock (SCK). The serial control interface is used to program and read the on-chip mode registers.

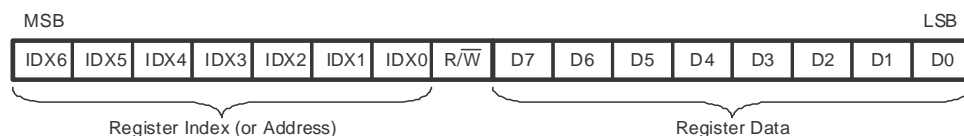
The control interface includes MISO (pin 24), MOSI (pin 11), MC (pin 12), and MS (pin 18). MISO (Master In Slave Out) is the serial data output, used to read back the values of the mode registers; MOSI (Master Out Slave In) is the serial data input, used to program the mode registers.

MC is the serial bit clock, used to shift data in and out of the control port by falling edge of MC, and MS is the mode control enable with LOW active, used to enable the internal mode register access. If feedback from the device is not required, the MISO pin can be assigned to GPIO1 by register control.

##### 8.4.1.1.1.1 Register Read and Write Operation

All read/write operations for the serial control port use 16-bit data words. [Figure 64](#) shows the control data word format. The most significant bit is the read/write bit. For write operations, the bit must be set to 0. For read operations, the bit must be set to 1. There are seven bits, labeled IDX[6:0], that hold the register index (or address) for the read and write operations. The least significant eight bits, D[7:0], contain the data to be written to, or the data that was read from, the register specified by IDX[6:0].

[Figure 64](#) and [Figure 65](#) show the functional timing diagram to write or read through the serial control port. MS is held at a logic-1 state until a register access. To start the register write or read cycle, set MS to logic 0. Sixteen clocks are then provided on MC, corresponding to the 16 bits of the control data word on MOSI and read-back data on MISO. After the eighth clock cycle has completed, the data from the indexed-mode control register appears on MISO during the read operation. After the sixteenth clock cycle has completed, the data is latched into the indexed-mode control register during the write operation. To write or read subsequent data, MS is set to logic 1 once (see  $t_{MHH}$  in [Figure 69](#)).



**Figure 64. Control Data Word Format; MDI**

#### NOTE

B8 is used for selection of *Write* or *Read*. Setting = 0 indicates a *Write*, while = 1 indicates a *Read*. Bits 15–9 are used for register address. Bits 7–0 are used for register data. Multiple-byte write or read (up to 8 bytes) is supported while MS is kept low. The address field becomes the initial address, automatically incrementing for each byte.



Device Functional Modes (continued)

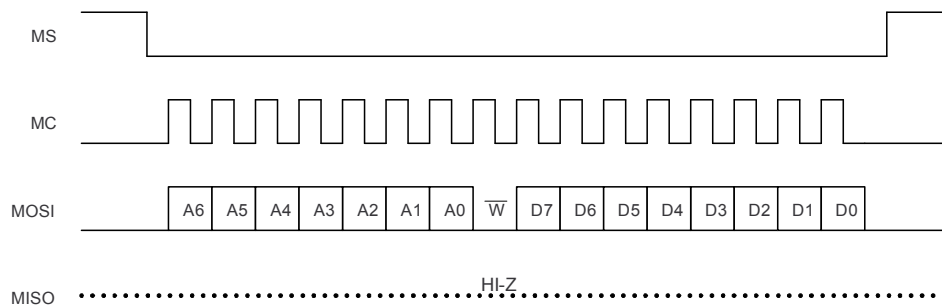


Figure 65. Serial Control Format; Write, Single Byte

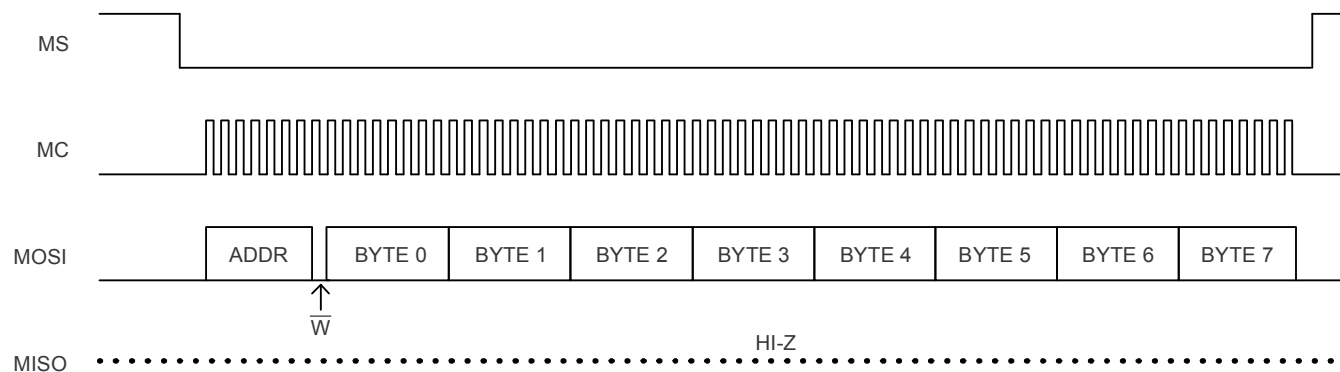


Figure 66. Serial Control Format; Write, Multiple Byte

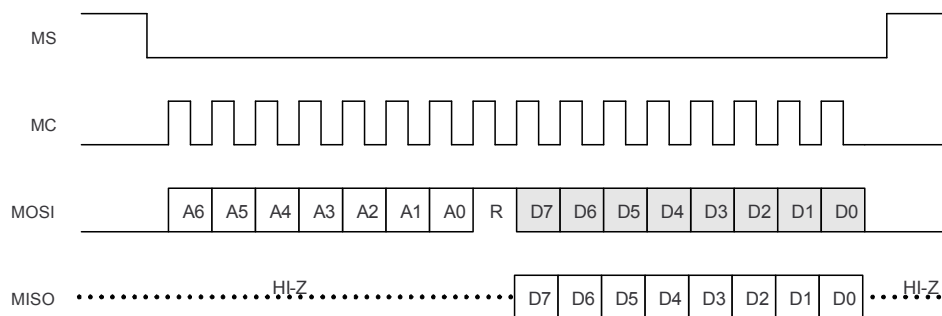
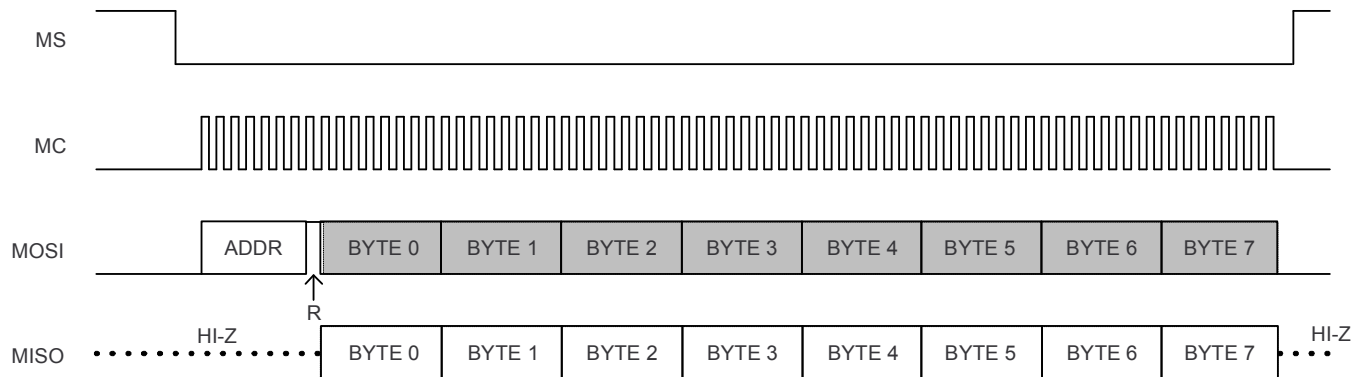
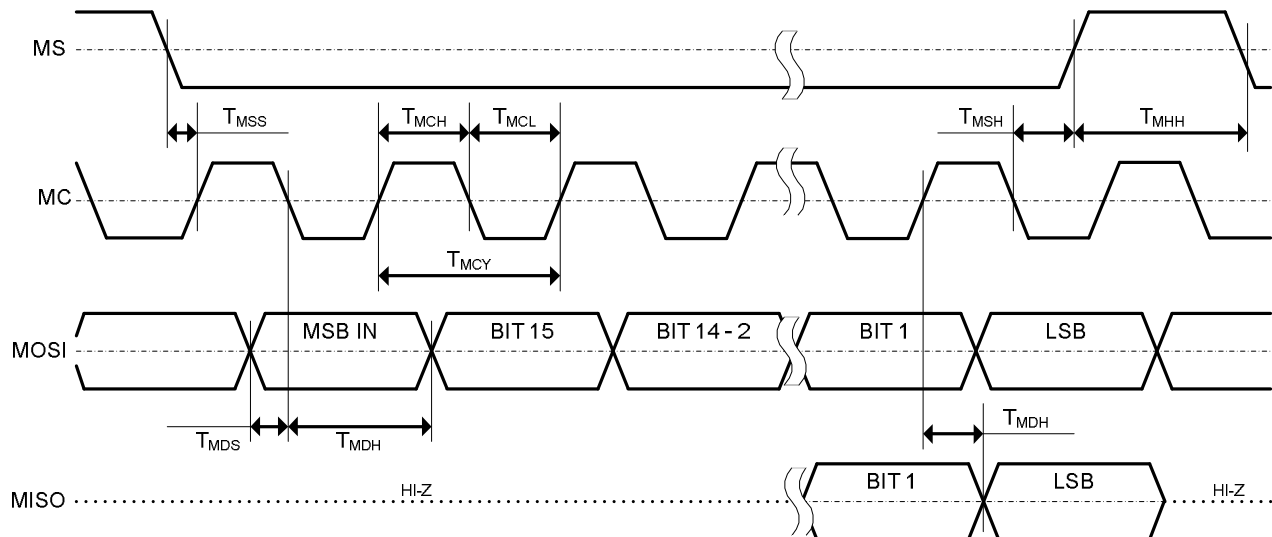


Figure 67. Serial Control Format; Read

**Device Functional Modes (continued)**

**Figure 68. Serial Control Format; Read, Multiple Byte**

**Figure 69. Control Interface Timing**
**Table 29. Control Interface Timing**

		MIN	MAX	UNIT
$t_{MCY}$	MC Pulse Cycle Time	100		ns
$t_{MCL}$	MC Low Level Time	40		ns
$t_{MCH}$	MC High Level Time	40		ns
$t_{MHH}$	$\overline{MS}$ High Level Time	20		ns
$t_{MSS}$	$\overline{MS}$ $\downarrow$ Edge to MC $\uparrow$ Edge	30		ns
$t_{MSH}$	$\overline{MS}$ Hold Time <sup>(1)</sup>	30		ns
$t_{MDH}$	MDI Hold Time	15		ns
$t_{MDS}$	MDI Set-up Time	15		ns
$t_{MOS}$	MC Rise Edge to MDO Stable		20	ns

(1) MC falling edge for LSB to MS rising edge.

8.4.1.1.2 I<sup>2</sup>C Interface

The PCM5252 supports the I<sup>2</sup>C serial bus and the data transmission protocol for standard and fast mode as a slave device.

In I<sup>2</sup>C mode, the control terminals are changed as follows.

Table 30. I<sup>2</sup>C Pins and Functions

SIGNAL	PIN	I/O	DESCRIPTION
SDA	11	I/O	I <sup>2</sup> C data
SCL	12	I	I <sup>2</sup> C clock
ADR2	16	I	I <sup>2</sup> C address 2
ADR1	24	I	I <sup>2</sup> C address 1

8.4.1.1.2.1 Slave Address

Table 31. I<sup>2</sup>C Slave Address

MSB							LSB
1	0	0	1	1	ADR2	ADR1	R/ $\bar{W}$

The PCM5252 has 7 bits for its own slave address. The first five bits (MSBs) of the slave address are factory preset to 10011 (0x9x). The next two bits of the address byte are the device select bits which can be user-defined by the ADR1 and ADR0 terminals. A maximum of four devices can be connected on the same bus at one time. This gives a range of 0x98, 0x9A, 0x9C and 0x9E. Each PCM5252 responds when it receives its own slave address.

8.4.1.1.2.2 Register Address Auto-Increment Mode

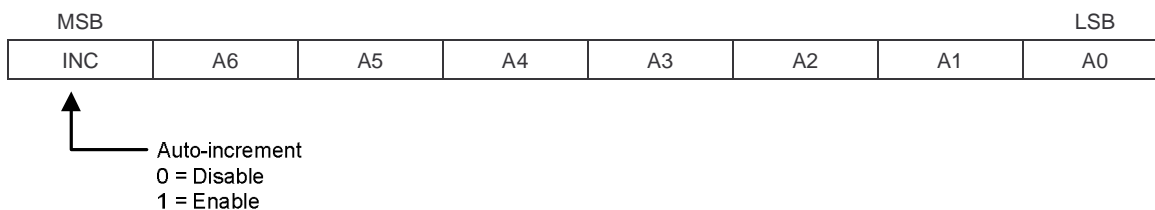


Figure 70. Auto Increment Mode

Auto-increment mode allows multiple sequential register locations to be written to or read back in a single operation, and is especially useful for block write and read operations.

8.4.1.1.2.3 Packet Protocol

A master device must control packet protocol, which consists of start condition, slave address, read/write bit, data if write or acknowledge if read, and stop condition. The PCM5252 supports only slave receivers and slave transmitters.

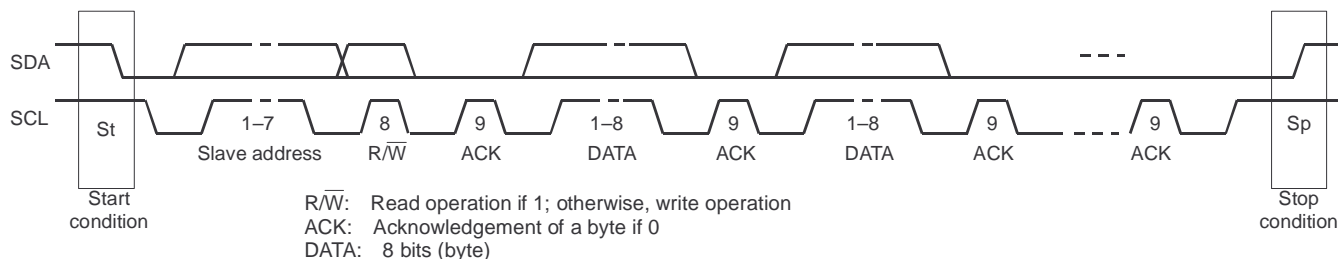


Figure 71. Packet Protocol

**Table 32. Write Operation - Basic I<sup>2</sup>C Framework**

Transmitter	M	M	M	S	M	S	M	S		S	M
Data Type	St	slave address	R/	ACK	DATA	ACK	DATA	ACK		ACK	Sp

**Table 33. Read Operation - Basic I<sup>2</sup>C Framework**

Transmitter	M	M	M	S	S	M	S	M		M	M
Data Type	St	slave address	R/	ACK	DATA	ACK	DATA	ACK		NACK	Sp

M = Master Device; S = Slave Device; St = Start Condition; Sp = Stop Condition

#### 8.4.1.1.2.4 Write Register

A master can write to any PCM5252 registers using single or multiple accesses. The master sends a PCM5252 slave address with a write bit, a register address with auto-increment bit, and the data. If auto-increment is enabled, the address is that of the starting register, followed by the data to be transferred. When the data is received properly, the index register is incremented by 1 automatically. When the index register reaches 0x7F, the next value is 0x0. [Table 34](#) shows the write operation.

**Table 34. Write Operation**

Transmitter	M	M	M	S	M	S	M	S	M	S		S	M	
Data Type	St	slave addr	W	ACK	inc	reg addr	ACK	write data 1	ACK	write data 2	ACK		ACK	Sp

M = Master Device; S = Slave Device; St = Start Condition; Sp = Stop Condition; W = Write; ACK = Acknowledge

#### 8.4.1.1.2.5 Read Register

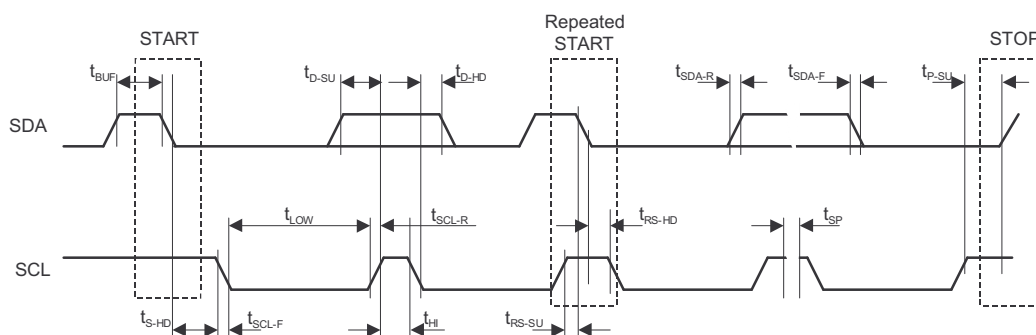
A master can read the PCM5252 register. The value of the register address is stored in an indirect index register in advance. The master sends a PCM5252 slave address with a read bit after storing the register address. Then the PCM5252 transfers the data which the index register points to. When auto-increment is enabled, the index register is incremented by 1 automatically. When the index register reaches 0x7F, the next value is 0x0. [Table 35](#) shows the read operation.

**Table 35. Read Operation**

Transmitter	M	M	M	S	M	S	M	M	M	S	S	M		M	M	
Data Type	St	slave addr	W	ACK	inc	reg addr	ACK	Sr	slave addr	R	ACK	data	ACK		NACK	Sp

M = Master Device; S = Slave Device; St = Start Condition; Sr = Repeated Start Condition; Sp = Stop Condition; W = Write; R = Read; NACK = Not acknowledge

#### 8.4.1.1.2.6 Timing Characteristics


**Figure 72. Register Access Timing**

**Table 36. I<sup>2</sup>C Bus Timing**

			MIN	MAX	UNIT
f <sub>SCL</sub>	SCL clock frequency	Standard		100	kHz
		Fast		400	kHz
t <sub>BUF</sub>	Bus free time between a STOP and START condition	Standard	4.7		μs
		Fast	1.3		
t <sub>LOW</sub>	Low period of the SCL clock	Standard	4.7		μs
		Fast	1.3		
t <sub>HI</sub>	High period of the SCL clock	Standard	4.0		μs
		Fast	600		ns
t <sub>RS-SU</sub>	Setup time for (repeated)START condition	Standard	4.7		μs
		Fast	600		ns
t <sub>S-HD</sub>	Hold time for (repeated)START condition	Standard	4.0		μs
t <sub>RS-HD</sub>		Fast	600		ns
t <sub>D-SU</sub>	Data setup time	Standard	250		ns
		Fast	100		
t <sub>D-HD</sub>	Data hold time	Standard	0	900	ns
		Fast	0	900	
t <sub>SCL-R</sub>	Rise time of SCL signal	Standard	20 + 0.1C <sub>B</sub>	1000	ns
		Fast	20 + 0.1C <sub>B</sub>	300	
t <sub>SCL-R1</sub>	Rise time of SCL signal after a repeated START condition and after an acknowledge bit	Standard	20 + 0.1C <sub>B</sub>	1000	ns
		Fast	20 + 0.1C <sub>B</sub>	300	
t <sub>SCL-F</sub>	Fall time of SCL signal	Standard	20 + 0.1C <sub>B</sub>	1000	ns
		Fast	20 + 0.1C <sub>B</sub>	300	
t <sub>SDA-R</sub>	Rise time of SDA signal	Standard	20 + 0.1C <sub>B</sub>	1000	ns
		Fast	20 + 0.1C <sub>B</sub>	300	
t <sub>SDA-F</sub>	Fall time of SDA signal	Standard	20 + 0.1C <sub>B</sub>	1000	ns
		Fast	20 + 0.1C <sub>B</sub>	300	
t <sub>P-SU</sub>	Setup time for STOP condition	Standard	4.0		μs
		Fast	600		ns
C <sub>B</sub>	Capacitive load for SDA and SCL line			400	pF
t <sub>SP</sub>	Pulse width of spike suppressed	Fast		50	ns
V <sub>NH</sub>	Noise margin at High level for each connected device (including hysteresis)		0.2 × V <sub>DD</sub>		V

#### 8.4.2 VREF and VCOM Modes

See [Choosing Between VREF and VCOM Modes](#) for information on configuring these modes.

## 9 Application and Implementation

### NOTE

Information in the following applications sections is not part of the TI component specification, and TI does not warrant its accuracy or completeness. TI's customers are responsible for determining suitability of components for their purposes. Customers should validate and test their design implementation to confirm system functionality.

### 9.1 Application Information

### 9.2 Typical Application

Differential outputs DAC's are regularly used where higher performance is required from them compared to single ended output DACs. They offer twice as much output voltage for the same power supply, along with noise cancelling effect of differential signaling. The PCM5252 makes an ideal front end for both analog input speaker amplifiers and headphone amplifiers with its higher voltage differential output and low noise floor.

#### 9.2.1 High Fidelity Smartphone Application

A new trend in portable applications are termed "Hifi Smartphones". In these systems, a standard portable audio codec continues to be used for telephony, while a separate, higher performance DAC and Headphone Amplifier is used for music playback.

Figure 73 shows a complete circuit schematic for such a system. The digital audio is fed into a high performance DAC. The PCM5252 is a 32-bit, stereo DAC. The PCM5252 is pin to pin and register set compatible with the PCM5242. The PCM5252 contains an expanded ROM that contains the Smart Amplifier Algorithm components.

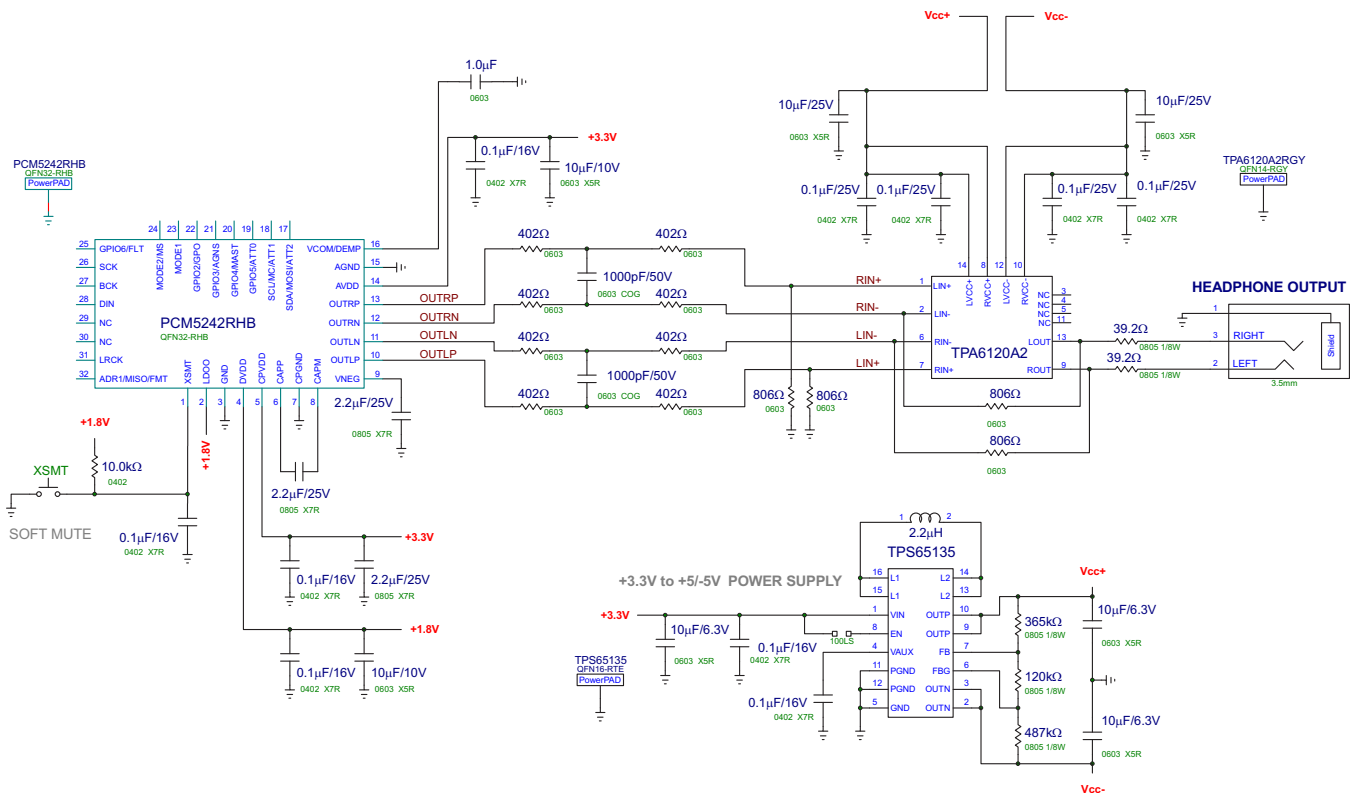


Figure 73. High Fidelity Smartphone Application

## Typical Application (continued)

### 9.2.1.1 Design Requirements

- Directpath output to headphone amplifier
- 1VRMS output, as 2VRMS may cause hearing damage into low impedance headphones
- Stereo differential inputs (DAC is differential)
- Be transparent to the user. (DAC SNR and THD+N performance all the way to the headphone)
- Automatic  $f_s$  switching up to 384kHz
- 3-wire I<sup>2</sup>S source

### 9.2.1.2 Detailed Design Procedure

For optimal performance, the TPA6120A2 is configured for use with differential inputs, stereo use, and a gain of 1V/V.

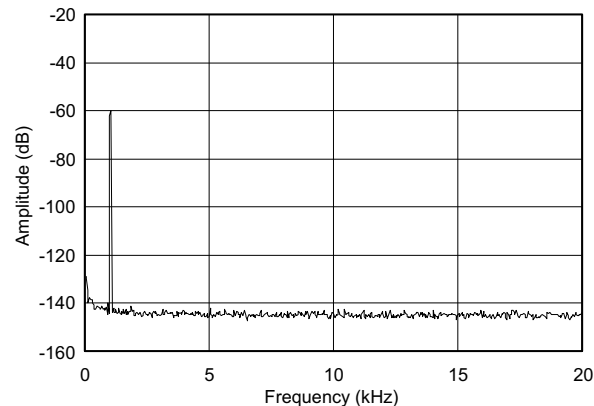
The TPA6120A2 requires a bipolar power supply to drive a ground centered output. The application employs a TPS65135 DC-DC converter that generates  $\pm 5V$  from a single 3.3V supply.

The PCM5252 DAC is configured for a 1VRMS output so that clipping is avoided should the 3.3V power supply sag. The PCM5252 offers a ground centered output, so that no DC blocking capacitors are required between it and the TPA6120A2. (Page 1, Register 2)

#### 9.2.1.2.1 Initialization Script

```
w 98 00 01 # PCM5252 to Page 1
w 98 02 11 # PCM5252 output to 1 Vrms
w 98 00 00 # PCM5252 back to page 0
w 98 3B 66 # set auto mute time to six seconds of audio zero.
w 98 3C 01 # Left Vol register controls both
w 98 3D 4F # Change left channel volume, right will follow.
w 98 3F BB # set vol changes for every 4 samples, 0.5 sample steps.
```

### 9.2.1.3 Application Performance Plot



**Figure 74. 2 FFT Plot At -60db Input**

In this particular application, the TPA6120A2's performance is transparent and the performance of the system is dictated by the PCM5252 DAC, even into a 32- $\Omega$  headphone load.

## 10 Power Supply Recommendations

### 10.1 Power Supply Distribution and Requirements

The PCM5252 devices are powered through the pins shown in [Figure 75](#).

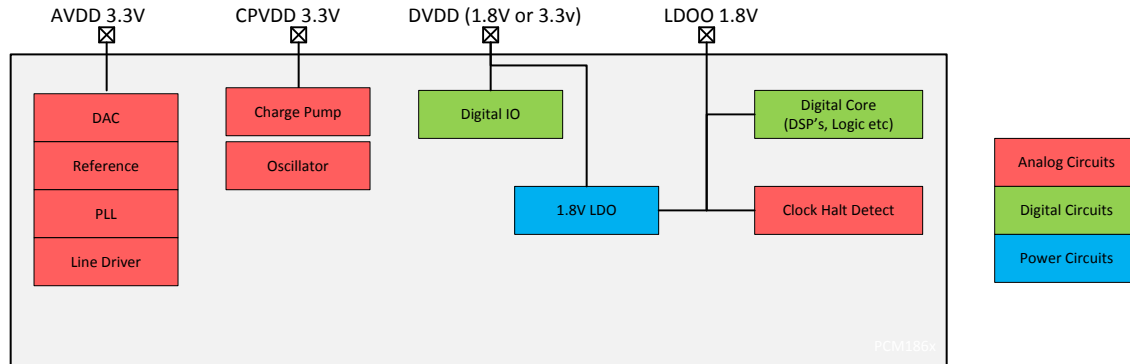


Figure 75. Power Distribution Tree Within PCM5252

Table 37. Power Supply Pin Descriptions

NAME	USAGE / DESCRIPTION
AVDD	Analog voltage supply; must be 3.3 V. This powers all analog circuitry that the DAC runs on.
DVDD	Digital voltage supply. This is used as the I/O voltage control and the input to the onchip LDO.
CPVDD	Charge Pump Voltage Supply - must be 3.3 V
LDOO	Output from the onchip LDO. Should be used with a 0.1- $\mu$ F decoupling cap. Can be driven (used as power input) with a 1.8-V supply to bypass the onchip LDO for lower power consumption.
AGND	Analog ground
DGND	Digital ground



## 10.2 Recommended Powerdown Sequence

Under certain conditions, the PCM5252 devices can exhibit some pops on power down. Pops are caused by a device not having enough time to detect power loss and start the muting process.

The PCM5252 devices have two auto-mute functions to mute the device upon power loss (intentional or unintentional).

### 10.2.1 XSMT = 0

When the XSMT pin is pulled low, the incoming PCM data is attenuated to 0, closely followed by a hard analog mute. This process takes  $150 \text{ sample times } (t_s) + 0.2 \text{ ms}$ .

Because this mute time is mainly dominated by the sampling frequency, systems sampling at 192 kHz will mute much faster than a 48-kHz system.

### 10.2.2 Clock Error Detect

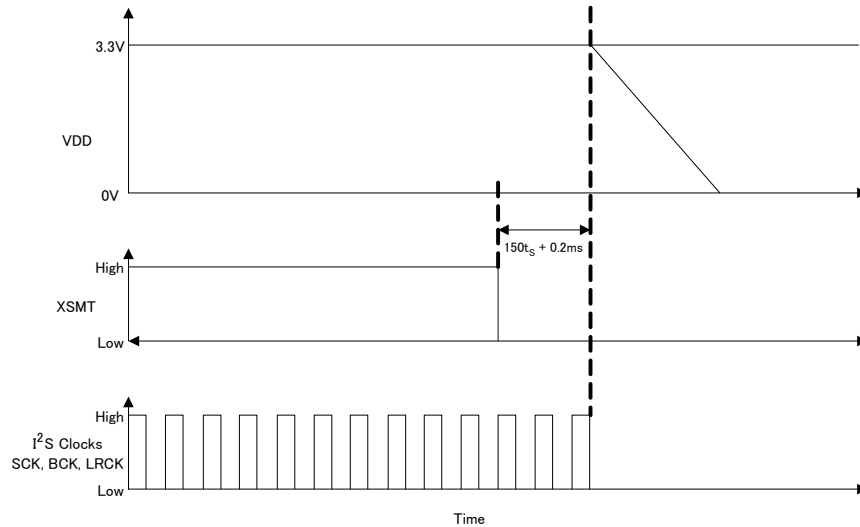
When clock error is detected on the incoming data clock, the PCM5252 devices switch to an internal oscillator, and continue to drive the output, while attenuating the data from the last known value. Once this process is complete, the PCM5252 outputs are hard muted to ground.

## Recommended Powerdown Sequence (continued)

### 10.2.3 Planned Shutdown

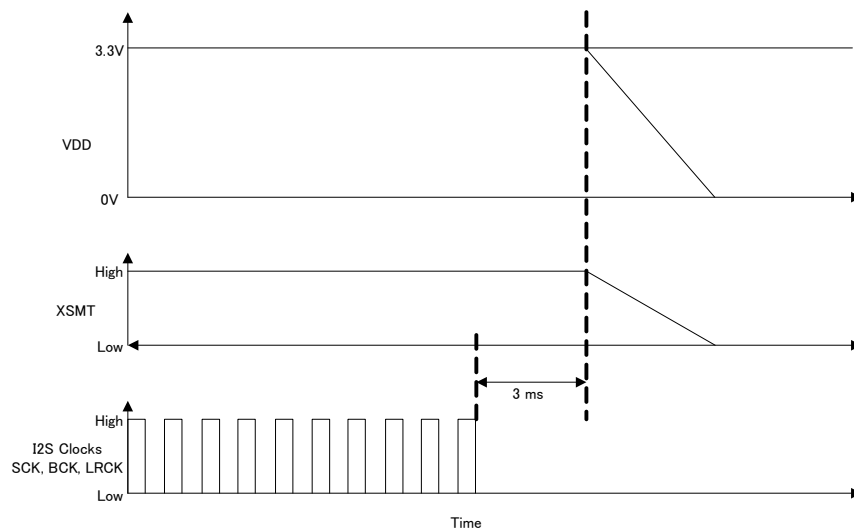
These auto-muting processes can be manipulated by system designs to mute before power loss in the following ways:

1. Assert XSMT low  $150t_s + 0.2\text{ ms}$  before power is removed.



**Figure 76. Assert XSMT**

2. Stop I<sup>2</sup>S clocks (SCK, BCK, LRCK) 3 ms before powerdown as shown in [Figure 77](#).



**Figure 77. Stop I<sup>2</sup>C Clocks**

### 10.2.4 Unplanned Shutdown

Many systems use a low-noise regulator to provide an AVDD 3.3-V supply for the DAC. The XSMT Pin can take advantage of such a feature to measure the pre-regulated output from the system SMPS to mute the output before the entire SMPS discharges. [Figure 78](#) shows how to configure such a system to use the XSMT pin. The XSMT pin can also be used in parallel with a GPIO pin from the system microcontroller/DSP or power supply.

Recommended Powerdown Sequence (continued)

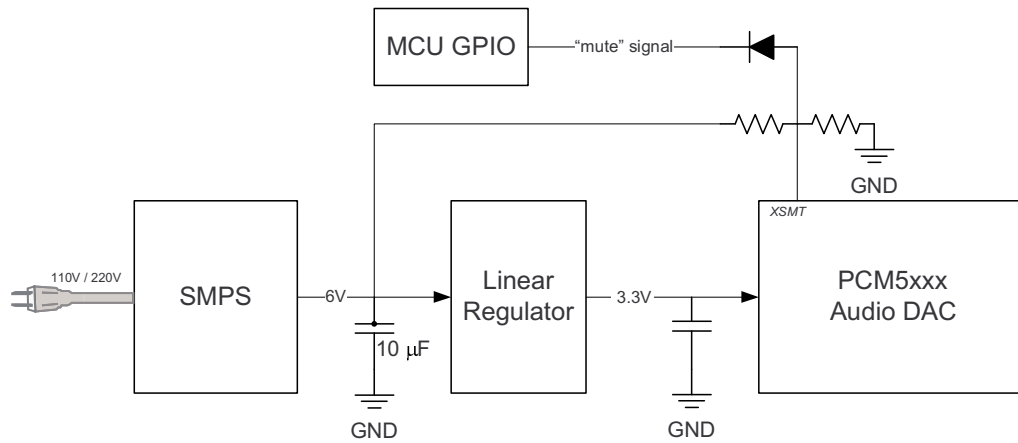


Figure 78. Using the XSMT Pin

### 10.3 External Power Sense Undervoltage Protection Mode

---

#### NOTE

External Power Sense Undervoltage Protection Mode is supported only when  $DV_{DD} = 3.3\text{ V}$ .

---

The XSMT pin can also be used to monitor a system voltage, such as the 24-VDC LCD TV backlight, or 12-VDC system supply using a voltage divider created with two resistors. (See [Figure 79](#).)

- If the XSMT pin makes a transition from 1 to 0 over 6 ms or more, the device switches into external undervoltage protection mode. This mode uses two trigger levels:
  - When the XSMT pin level reaches 2 V, soft mute process begins.
  - When the XSMT pin level reaches 1.2 V, analog mute engages, regardless of digital audio level, and shutdown begins. (DAC and related circuitry powers down).

A timing diagram to show this is shown in [Figure 80](#).

---

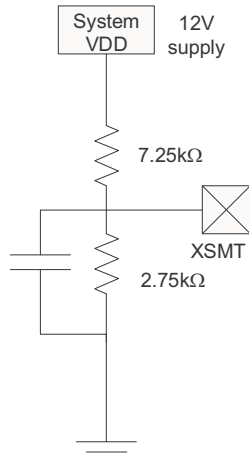
#### NOTE

The XSMT input pin voltage range is from  $-0.3\text{ V}$  to  $DV_{DD} + 0.3\text{ V}$ . The ratio of external resistors must produce a voltage within this input range. Any increase in power supply (such as power supply positive noise or ripple) can pull the XSMT pin higher than  $DV_{DD} + 0.3\text{ V}$ .

---

For example, if the PCM5252 is monitoring a 12-V input, and dividing the voltage by 4, then the voltage at XSMT during ideal power supply conditions is 3.3 V. A voltage spike higher than 14.4 V causes a voltage greater than 3.6 V ( $DV_{DD} + 0.3$ ) on the XSMT pin, potentially damaging the device.

Providing the divider is set appropriately, any DC voltage can be monitored.



**Figure 79. XSMT in External UVP Mode**

External Power Sense Undervoltage Protection Mode (continued)

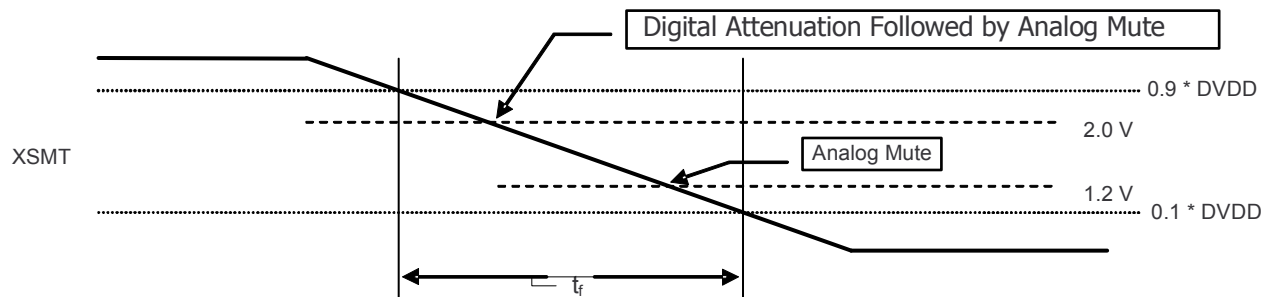
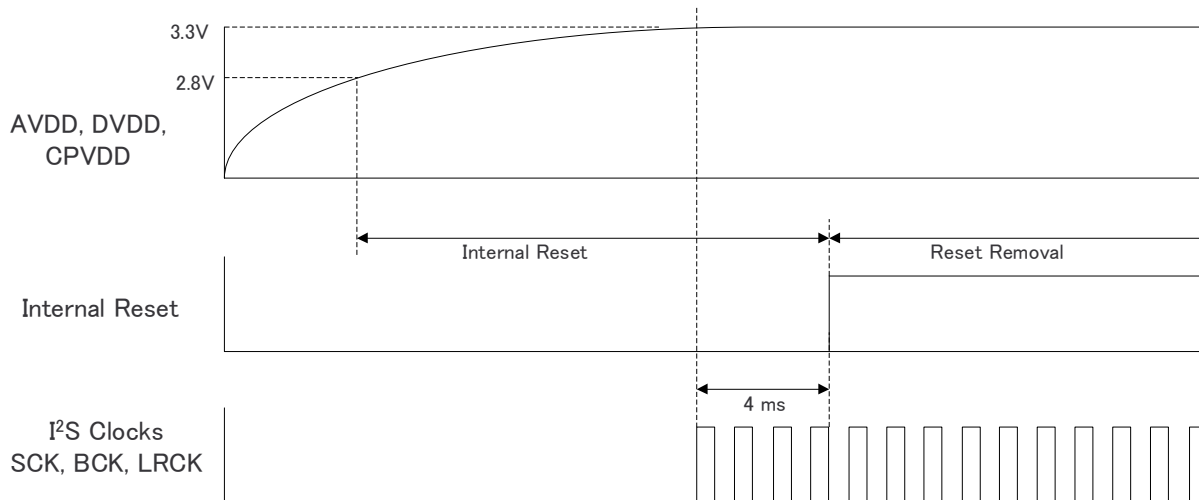


Figure 80. XSMT Timing for Undervoltage Protection

## 10.4 Power-On Reset Function

### 10.4.1 Power-On Reset, DVDD 3.3-V Supply

The PCM5252 includes a power-on reset function, as shown in [Figure 81](#). With  $V_{DD} > 2.8$  V, the power-on reset function is enabled. After the initialization period, the PCM5252 is set to its default reset state. Analog output will begin ramping after valid data has been passing through the device for the given group delay given by the digital interpolation filter selected.



**Figure 81. Power-On Reset Timing, DVDD = 3.3 V**

## Power-On Reset Function (continued)

### 10.4.2 Power-On Reset, DVDD 1.8-V Supply

The PCM5252 includes a power-on reset function, as shown in Figure 82. With AVDD greater than approximately 2.8 V, CPVDD greater than approximately 2.8 V, and DVDD greater than approximately 1.5 V, the power-on reset function is enabled. After the initialization period, the PCM5252 is set to its default reset state.

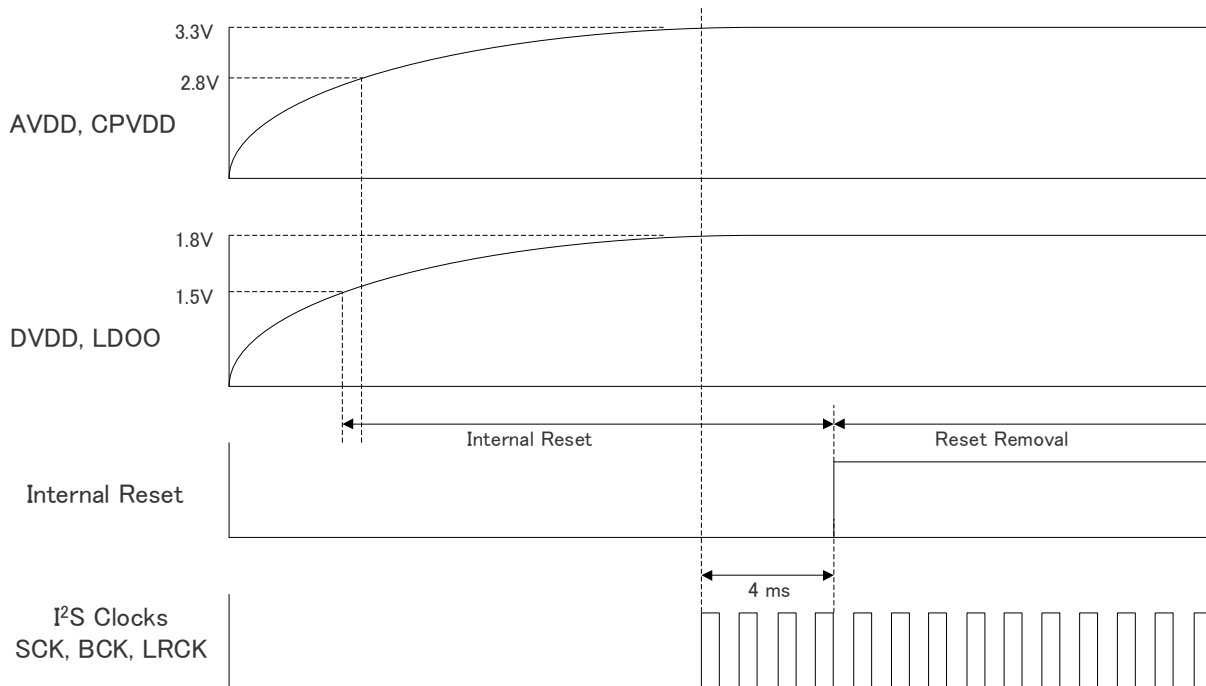


Figure 82. Power-On Reset Timing, DVDD = 1.8 V

## 10.5 PCM5252 Power Modes

### 10.5.1 Setting Digital Power Supplies and I/O Voltage Rails

The internal digital core of the PCM5252 devices run from a 1.8-V supply. This can be generated by the internal LDO, or by an external 1.8-V supply.

DVDD is used to set the I/O voltage, and to be used as the input to the onchip LDO that creates the 1.8 V required by the digital core.

For systems that require 3.3-V I/O support, but lower power consumption, DVDD should be connected to 3.3 V and LDOO can be connected to an external 1.8-V source. Doing so will disable the onchip LDO.

When setting I/O voltage to be 1.8 V, both DVDD and LDOO must be provided with an external 1.8-V supply.

### 10.5.2 Power Save Modes

The PCM5252 devices offer two power-save modes: standby and power-down.

When a clock error (SCK, BCK, and LRCK) or clock halt is detected, the PCM5252 device automatically enters standby mode. The DAC and line driver are also powered down. The device can also be placed in standby mode via software command.

When BCK and LRCK remain at a low level for more than 1 second, the PCM5252 device automatically enters powerdown mode. Power-down mode disables the negative charge pump and bias/reference circuit, in addition to those disabled in standby mode. The device can also be placed in power-down mode via software command.

The detection time of BCK and LRCK halt can be controlled by Page 0, Register 44, D(2:0).

### PCM5252 Power Modes (continued)

When expected audio clocks (SCK, BCK, LRCK) are applied to the PCM5252 device, or if BCK and LRCK start correctly while SCK remains at ground level for 16 successive LRCK periods, the device starts its powerup sequence automatically.

#### 10.5.3 Power Save Parameter Programming

**Table 38. Power Save Registers**

REGISTER	DESCRIPTION
Page 0, Register 2, D(4)	Software standby mode command
Page 0, Register 2, D(0)	Software power-down command
Page 0, Register 2, D(4) and D(0)	Software power-up sequence command (required after software standby or power-down)
Page 0, Register 44, D(2:0)	Detection time of BCK and LRCK halt



## 11 Layout

### 11.1 Layout Guidelines

- The PCM5252 family of devices are simple to layout. Most engineers use a shared common ground for an entire device. GND can consider AGND and DGND connected.
- Good system partitioning should keep digital clock and interface traces away from the differential analog outputs for highest analog performance. This reduces any high-speed clock return currents influencing the analog outputs.
- Power supply and charge pump decoupling capacitors should be placed as close as possible to the device.
- The thermal pad on the underside of the package should be connected to GND.
- The top layer should be used for routing signals, whilst the bottom layer can be used for GND.

### 11.2 Layout Example

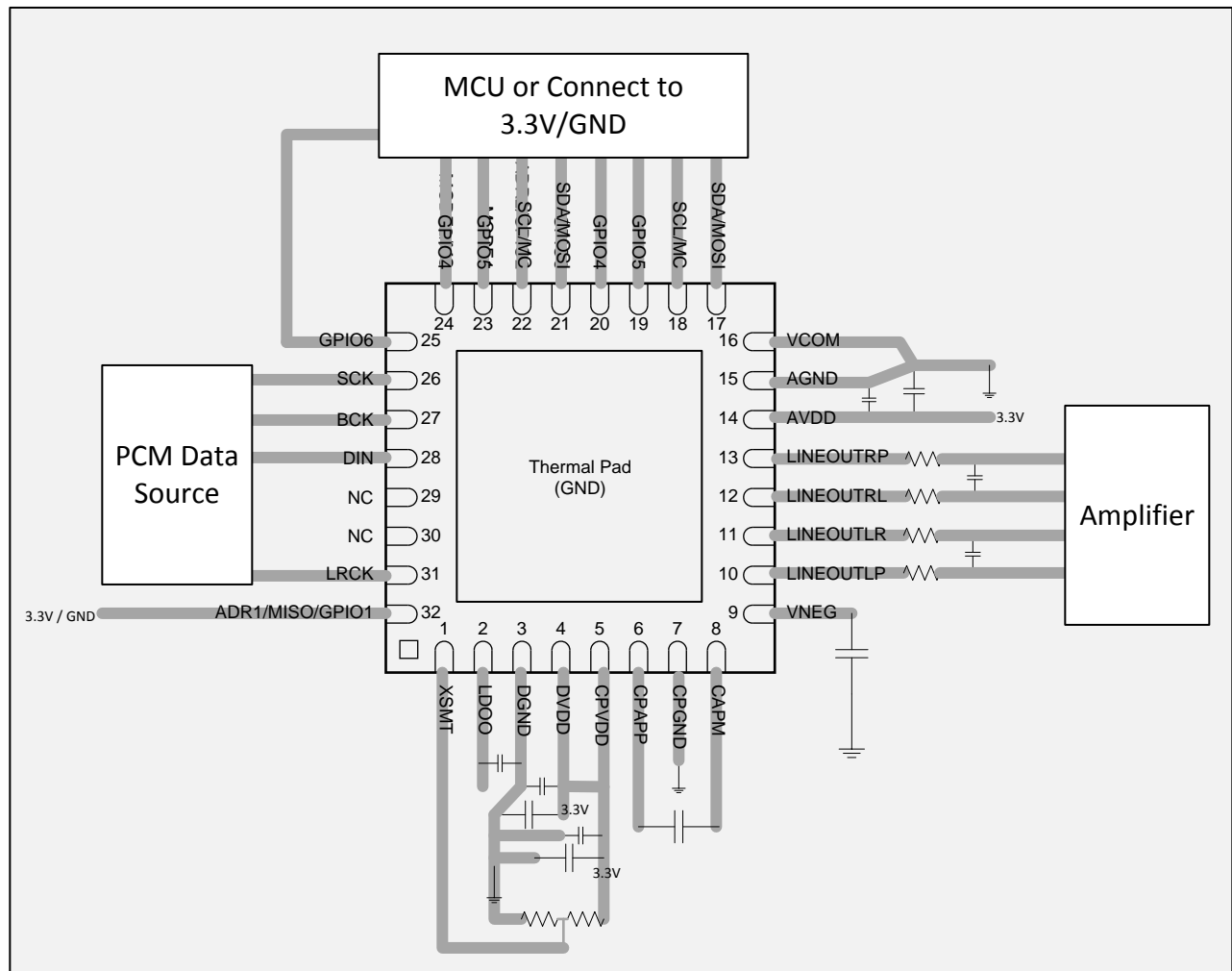


Figure 83. PCM5252 Layout Example

## 12 Programming

### 12.1 Coefficient Data Formats

All mixer gain coefficients are 24-bit coefficients using a 4.20 number format. Numbers formatted as 4.20 numbers have 4 bits to the left of the binary point and 20 bits to the right of the binary point. If the most significant bit is logic 0, the number is a positive number. If the most significant bit is a logic 1, then the number is a negative number. In this case, every bit must be inverted, a 1 added to the result.

### 12.2 Power Down and Reset Behavior

Register values including those in the Coefficient Memory and Instruction Memory should remain when the device is put into power down mode. (PG0 Reg 0x02).

Register values in the device are reset to defaults when bit 0 or 4 of (Pg0, Reg 0x01) is set to 1. Please see the register description for more information.

## 13 Register Maps

### 13.1 PCM5252 Register Map

In any page, register 0 is the Page Select Register. The register value selects the Register Page from 0 to 255 for next read or write command.

**Table 39. Register Map Overview**

REGISTER NUMBER	DESCRIPTION
<b>Page 0</b>	
0	Page select register
1	Analog control register
2	Standby, Powerdown requests
3	Mute
4	PLL Lock Flag, PLL enable
5	Reserved
6	SPI MISO function select
7	De-emphasis enable, SDOOUT select
8	GPIO enables
9	BCK, LRCLK configuration
10	DSP GPIO Input
11	Reserved
12	Master mode BCK, LRCLK reset
13	PLL clock source select
14 - 19	Reserved
20 - 24	PLL dividers
25, 26	Reserved
27	DSP clock divider
28	DAC clock divider
29	NCP clock divider
30	OSR clock divider
31	Reserved
32, 33	Master mode dividers
34	$f_s$ speed mode
35, 36	IDAC (number of DSP clock cycles available in one audio frame)
37	Ignore various errors
38,39	Reserved
40, 41	I <sup>2</sup> S configuration
42	DAC data path
43	DSP program selection
44	Clock missing detection period
59	Auto mute time
60 - 64	Digital volume

**Table 39. Register Map Overview (continued)**

REGISTER NUMBER	DESCRIPTION
65	Auto mute
75 - 79	Reserved
80 - 85	GPIO output selection
86, 87	GPIO control
88, 89	Reserved
90	DSP overflow
91 - 94	Sample rate status
95 - 107	Reserved
108	Analog mute monitor
109 - 118	Reserved
119	GPIO input
120	Auto Mute flags
121	Reserved
<b>Page 1</b>	
1	Output amplitude type
2	Analog gain control
3, 4	Reserved
5	Undervoltage protection
6	Analog mute control
7	Analog gain boost
8, 9	VCOM configuration
<b>Page 44</b>	
1	Coefficient memory (CRAM) control
Pages 44 - 52	Coefficient buffer - A (256 coeffs x 24 bits) : See <a href="#">Table 41</a>
Pages 62 - 70	Coefficient buffer - B (256 coeffs x 24 bits) : See <a href="#">Table 42</a>
71 - 252	Reserved
Pages 152 - 186	Instruction buffer (1024 instruction x 25 bits), I512 - I1023 are reserved.: See <a href="#">Table 43</a>
Pages 187 - 252	Reserved
<b>Page 253</b>	
63, 64	Clock Flex Mode
Pages 254 - 255	Reserved

The PCM5252 has a register map split into multiple pages. Pages 0 and 1 control of the DAC and other on-chip peripherals. Pages 44 through 52 are used for Coefficient A memory, while Pages 62-70 are coefficient B memory. Pages 152-186 contain the miniDSP instruction memory. Page 253 is where the Clock Flex Mode register is located.

**Table 40. PCM5252 Register Page Structure**

Page:	0	1	2-43	44-52	53-61	62-70	71-151	152-186	187-252	253	254-255
Func:	Control	Analog Control	Reserved	Coefficient A	Reserved	Coefficient B	Reserved	Instruction	Reserved	Clock Flex	Clock Flex Mode
Desc:	General Control and Configuration	Analog Control		256 24-bit coefficients, 30 coefficients per page, 4 registers per coefficient		256 24-bit coefficients, 30 coefficients per page, 4 registers per coefficient		1024 24-bit instructions, 30 instructions per page, 4 registers per instruction			

**Table 41. Coefficient Buffer-A Map**

COEFF NO	PAGE NO	BASE REGISTER	BASE REGISTER + 0	BASE REGISTER + 1	BASE REGISTER + 2	BASE REGISTER + 3
C0	44	8	Coef(23:16)	Coef(15:8)	Coef(7:0)	Reserved.
C1	44	12	Coef(23:16)	Coef(15:8)	Coef(7:0)	Reserved.
..	..	..	..	..	..	..
C29	44	124	Coef(23:16)	Coef(15:8)	Coef(7:0)	Reserved.
C30	45	8	Coef(23:16)	Coef(15:8)	Coef(7:0)	Reserved.
..	..	..	..	..	..	..
C59	45	124	Coef(23:16)	Coef(15:8)	Coef(7:0)	Reserved.
C60	46	8	Coef(23:16)	Coef(15:8)	Coef(7:0)	Reserved.
..	..	..	..	..	..	..
C89	46	124	Coef(23:16)	Coef(15:8)	Coef(7:0)	Reserved.
C90	47	8	Coef(23:16)	Coef(15:8)	Coef(7:0)	Reserved.
..	..	..	..	..	..	..
C119	47	124	Coef(23:16)	Coef(15:8)	Coef(7:0)	Reserved.
C120	48	8	Coef(23:16)	Coef(15:8)	Coef(7:0)	Reserved.
..	..	..	..	..	..	..
C149	48	124	Coef(23:16)	Coef(15:8)	Coef(7:0)	Reserved.
C150	49	8	Coef(23:16)	Coef(15:8)	Coef(7:0)	Reserved.
..	..	..	..	..	..	..
C179	49	124	Coef(23:16)	Coef(15:8)	Coef(7:0)	Reserved.
C180	50	8	Coef(23:16)	Coef(15:8)	Coef(7:0)	Reserved.
..	..	..	..	..	..	..
C209	50	124	Coef(23:16)	Coef(15:8)	Coef(7:0)	Reserved.
C210	51	8	Coef(23:16)	Coef(15:8)	Coef(7:0)	Reserved.
..	..	..	..	..	..	..
C239	51	124	Coef(23:16)	Coef(15:8)	Coef(7:0)	Reserved.
C240	52	8	Coef(23:16)	Coef(15:8)	Coef(7:0)	Reserved.
..	..	..	..	..	..	..
C255	52	68	Coef(23:16)	Coef(15:8)	Coef(7:0)	Reserved.

**Table 42. Coefficient Buffer-B Map**

COEFF NO	PAGE NO	BASE REGISTER	BASE REGISTER + 0	BASE REGISTER + 1	BASE REGISTER + 2	BASE REGISTER + 3
C0	62	8	Coef(23:16)	Coef(15:8)	Coef(7:0)	Reserved.
C1	62	12	Coef(23:16)	Coef(15:8)	Coef(7:0)	Reserved.
..	..	..	..	..	..	..
C29	62	124	Coef(23:16)	Coef(15:8)	Coef(7:0)	Reserved.
C30	63	8	Coef(23:16)	Coef(15:8)	Coef(7:0)	Reserved.
..	..	..	..	..	..	..
C59	63	124	Coef(23:16)	Coef(15:8)	Coef(7:0)	Reserved.
C60	64	8	Coef(23:16)	Coef(15:8)	Coef(7:0)	Reserved.
..	..	..	..	..	..	..
C89	64	124	Coef(23:16)	Coef(15:8)	Coef(7:0)	Reserved.
C90	65	8	Coef(23:16)	Coef(15:8)	Coef(7:0)	Reserved.
..	..	..	..	..	..	..
C119	65	124	Coef(23:16)	Coef(15:8)	Coef(7:0)	Reserved.
C120	66	8	Coef(23:16)	Coef(15:8)	Coef(7:0)	Reserved.
..	..	..	..	..	..	..
C149	66	124	Coef(23:16)	Coef(15:8)	Coef(7:0)	Reserved.
C150	67	8	Coef(23:16)	Coef(15:8)	Coef(7:0)	Reserved.
..	..	..	..	..	..	..
C179	67	124	Coef(23:16)	Coef(15:8)	Coef(7:0)	Reserved.
C180	68	8	Coef(23:16)	Coef(15:8)	Coef(7:0)	Reserved.
..	..	..	..	..	..	..
C209	68	124	Coef(23:16)	Coef(15:8)	Coef(7:0)	Reserved.
C210	69	8	Coef(23:16)	Coef(15:8)	Coef(7:0)	Reserved.
..	..	..	..	..	..	..
C239	69	124	Coef(23:16)	Coef(15:8)	Coef(7:0)	Reserved.
C240	70	8	Coef(23:16)	Coef(15:8)	Coef(7:0)	Reserved.
..	..	..	..	..	..	..
C255	70	68	Coef(23:16)	Coef(15:8)	Coef(7:0)	Reserved.

**Table 43. miniDSP Instruction Map**

COEFF NO	PAGE NO	BASE REGISTER	BASE REGISTER + 0	BASE REGISTER + 1	BASE REGISTER + 2	BASE REGISTER + 3
I0	152	8	Instr(31:24)	Instr(23:16)	Instr(15:8)	Instr(7:0)
I1	152	12	Instr(31:24)	Instr(23:16)	Instr(15:8)	Instr(7:0)
..	..	..	..	..	..	..
I29	152	124	Instr(31:24)	Instr(23:16)	Instr(15:8)	Instr(7:0)
I30	153	8	Instr(31:24)	Instr(23:16)	Instr(15:8)	Instr(7:0)
..	..	..	..	..	..	..
I59	153	124	Instr(31:24)	Instr(23:16)	Instr(15:8)	Instr(7:0)
I60	154	8	Instr(31:24)	Instr(23:16)	Instr(15:8)	Instr(7:0)
..	..	..	..	..	..	..
I89	154	124	Instr(31:24)	Instr(23:16)	Instr(15:8)	Instr(7:0)
I90	155	8	Instr(31:24)	Instr(23:16)	Instr(15:8)	Instr(7:0)
..	..	..	..	..	..	..
I119	155	124	Instr(31:24)	Instr(23:16)	Instr(15:8)	Instr(7:0)
I120	156	8	Instr(31:24)	Instr(23:16)	Instr(15:8)	Instr(7:0)
..	..	..	..	..	..	..
I149	156	124	Instr(31:24)	Instr(23:16)	Instr(15:8)	Instr(7:0)
I150	157	8	Instr(31:24)	Instr(23:16)	Instr(15:8)	Instr(7:0)
..	..	..	..	..	..	..
I179	157	124	Instr(31:24)	Instr(23:16)	Instr(15:8)	Instr(7:0)
I180	158	8	Instr(31:24)	Instr(23:16)	Instr(15:8)	Instr(7:0)
..	..	..	..	..	..	..
I209	158	124	Instr(31:24)	Instr(23:16)	Instr(15:8)	Instr(7:0)
I210	159	8	Instr(31:24)	Instr(23:16)	Instr(15:8)	Instr(7:0)
..	..	..	..	..	..	..

**Table 43. miniDSP Instruction Map (continued)**

COEFF NO	PAGE NO	BASE REGISTER	BASE REGISTER + 0	BASE REGISTER + 1	BASE REGISTER + 2	BASE REGISTER + 3
I239	159	124	Instr(31:24)	Instr(23:16)	Instr(15:8)	Instr(7:0)
I240	160	8	Instr(31:24)	Instr(23:16)	Instr(15:8)	Instr(7:0)
..	..	..	..	..	..	..
I269	160	124	Instr(31:24)	Instr(23:16)	Instr(15:8)	Instr(7:0)
I270	161	8	Instr(31:24)	Instr(23:16)	Instr(15:8)	Instr(7:0)
..	..	..	..	..	..	..
I299	161	124	Instr(31:24)	Instr(23:16)	Instr(15:8)	Instr(7:0)
I300	162	8	Instr(31:24)	Instr(23:16)	Instr(15:8)	Instr(7:0)
..	..	..	..	..	..	..
I329	162	124	Instr(31:24)	Instr(23:16)	Instr(15:8)	Instr(7:0)
I330	163	8	Instr(31:24)	Instr(23:16)	Instr(15:8)	Instr(7:0)
..	..	..	..	..	..	..
I359	163	124	Instr(31:24)	Instr(23:16)	Instr(15:8)	Instr(7:0)
I360	164	8	Instr(31:24)	Instr(23:16)	Instr(15:8)	Instr(7:0)
..	..	..	..	..	..	..
I389	164	124	Instr(31:24)	Instr(23:16)	Instr(15:8)	Instr(7:0)
I390	165	8	Instr(31:24)	Instr(23:16)	Instr(15:8)	Instr(7:0)
..	..	..	..	..	..	..
I419	165	124	Instr(31:24)	Instr(23:16)	Instr(15:8)	Instr(7:0)
I420	166	8	Instr(31:24)	Instr(23:16)	Instr(15:8)	Instr(7:0)
..	..	..	..	..	..	..
I449	166	124	Instr(31:24)	Instr(23:16)	Instr(15:8)	Instr(7:0)
I450	167	8	Instr(31:24)	Instr(23:16)	Instr(15:8)	Instr(7:0)
..	..	..	..	..	..	..
I479	167	124	Instr(31:24)	Instr(23:16)	Instr(15:8)	Instr(7:0)
I480	168	8	Instr(31:24)	Instr(23:16)	Instr(15:8)	Instr(7:0)
..	..	..	..	..	..	..
I509	168	124	Instr(31:24)	Instr(23:16)	Instr(15:8)	Instr(7:0)
I510	169	8	Instr(31:24)	Instr(23:16)	Instr(15:8)	Instr(7:0)
I511	169	12	Instr(31:24)	Instr(23:16)	Instr(15:8)	Instr(7:0)
..	..	..	..	..	..	..
I539	169	124	Reserved.	Reserved.	Reserved.	Reserved.
I540	170	8	Reserved.	Reserved.	Reserved.	Reserved.
..	..	..	..	..	..	..
I569	170	124	Reserved.	Reserved.	Reserved.	Reserved.
I570	171	8	Reserved.	Reserved.	Reserved.	Reserved.
..	..	..	..	..	..	..
I599	171	124	Reserved.	Reserved.	Reserved.	Reserved.
I600	172	8	Reserved.	Reserved.	Reserved.	Reserved.
..	..	..	..	..	..	..
I629	172	124	Reserved.	Reserved.	Reserved.	Reserved.
I630	173	8	Reserved.	Reserved.	Reserved.	Reserved.
..	..	..	..	..	..	..
I659	173	124	Reserved.	Reserved.	Reserved.	Reserved.
I660	174	8	Reserved.	Reserved.	Reserved.	Reserved.
..	..	..	..	..	..	..
I689	174	124	Reserved.	Reserved.	Reserved.	Reserved.
I690	175	8	Reserved.	Reserved.	Reserved.	Reserved.
..	..	..	..	..	..	..
I719	175	124	Reserved.	Reserved.	Reserved.	Reserved.
I720	176	8	Reserved.	Reserved.	Reserved.	Reserved.
..	..	..	..	..	..	..
I749	176	124	Reserved.	Reserved.	Reserved.	Reserved.
I750	177	8	Reserved.	Reserved.	Reserved.	Reserved.
..	..	..	..	..	..	..
I779	177	124	Reserved.	Reserved.	Reserved.	Reserved.

**Table 43. miniDSP Instruction Map (continued)**

COEFF NO	PAGE NO	BASE REGISTER	BASE REGISTER + 0	BASE REGISTER + 1	BASE REGISTER + 2	BASE REGISTER + 3
I780	178	8	Reserved.	Reserved.	Reserved.	Reserved.
..	..	..	..	..	..	..
I809	178	124	Reserved.	Reserved.	Reserved.	Reserved.
I810	179	8	Reserved.	Reserved.	Reserved.	Reserved.
..	..	..	..	..	..	..
I839	179	124	Reserved.	Reserved.	Reserved.	Reserved.
I840	180	8	Reserved.	Reserved.	Reserved.	Reserved.
..	..	..	..	..	..	..
I869	180	124	Reserved.	Reserved.	Reserved.	Reserved.
I870	181	8	Reserved.	Reserved.	Reserved.	Reserved.
..	..	..	..	..	..	..
I899	181	124	Reserved.	Reserved.	Reserved.	Reserved.
I900	182	8	Reserved.	Reserved.	Reserved.	Reserved.
..	..	..	..	..	..	..
I929	182	124	Reserved.	Reserved.	Reserved.	Reserved.
I930	183	8	Reserved.	Reserved.	Reserved.	Reserved.
..	..	..	..	..	..	..
I959	183	124	Reserved.	Reserved.	Reserved.	Reserved.
I960	184	8	Reserved.	Reserved.	Reserved.	Reserved.
..	..	..	..	..	..	..
I989	184	124	Reserved.	Reserved.	Reserved.	Reserved.
I990	185	8	Reserved.	Reserved.	Reserved.	Reserved.
..	..	..	..	..	..	..
I1019	185	124	Reserved.	Reserved.	Reserved.	Reserved.
I1020	186	8	Reserved.	Reserved.	Reserved.	Reserved.
..	..	..	..	..	..	..
I1023	186	20	Reserved.	Reserved.	Reserved.	Reserved.

**13.1.1 Detailed Register Descriptions**
**13.1.1.1 Register Map Summary**
**Table 44. Register Map Summary**

DEC	HEX	B7	B6	B5	B4	B3	B2	B1	B0
<b>Page 0</b>									
1	01	RSV	RSV	RSV	RSTM	RSV	RSV	RSV	RSTR
2	02	RSV	RSV	RSV	RQST	RSV	RSV	RSV	RQPD
3	03	RSV	RSV	RSV	RQML	RSV	RSV	RSV	RQMR
4	04	RSV	RSV	RSV	PLCK	RSV	RSV	RSV	PLLE
6	06	RSV	RSV	RSV	RSV	RSV	RSV	FSMI1	FSMI0
7	07	RSV	RSV	RSV	DEMP	RSV	RSV	RSV	SDSL
8	08	RSV	RSV	G6OE	G5OE	G4OE	G3OE	G2OE	G1OE
9	09	RSV	RSV	BCKP	BCKO	RSV	RSV	RSV	LRKO
10	0A	DSPG7	DSPG6	DSPG5	DSPG4	DSPG3	DSPG2	DSPG1	DSPG0
12	0C	RSV	RSV	RSV	RSV	RSV	RSV	RBCK	RLRK
13	0D	RSV	SREF2	SREF1	SREF0	RSV	RSV	RSV	RSV
14	0E	RSV	SDAC2	SDAC1	SDAC0	RSV	RSV	RSV	RSV
18	12	RSV	RSV	RSV	RSV	RSV	GRAF2	GRAF1	GRAF0
19	13	RSV	RSV	RSV	RSV	RSV	RSV	RSV	RQSY
20	14	RSV	RSV	RSV	RSV	PPDV3	PPDV2	PPDV1	PPDV0
21	15	RSV	RSV	PJDV5	PJDV4	PJDV3	PJDV2	PJDV1	PJDV0
22	16	RSV	RSV	PDDV13	PDDV12	PDDV11	PDDV10	PDDV9	PDDV8
23	17	PDDV7	PDDV6	PDDV5	PDDV4	PDDV3	PDDV2	PDDV1	PDDV0
24	18	RSV	RSV	RSV	RSV	PRDV3	PRDV2	PRDV1	PRDV0
27	1B	RSV	DDSP6	DDSP5	DDSP4	DDSP3	DDSP2	DDSP1	DDSP0
28	1C	RSV	DDAC6	DDAC5	DDAC4	DDAC3	DDAC2	DDAC1	DDAC0
29	1D	RSV	DNCP6	DNCP5	DNCP4	DNCP3	DNCP2	DNCP1	DNCP0
30	1E	RSV	DOSR6	DOSR5	DOSR4	DOSR3	DOSR2	DOSR1	DOSR0
32	20	RSV	DBCK6	DBCK5	DBCK4	DBCK3	DBCK2	DBCK1	DBCK0
33	21	DLRK7	DLRK6	DLRK5	DLRK4	DLRK3	DLRK2	DLRK1	DLRK0
34	22	RSV	RSV	RSV	I16E	RSV	RSV	FSSP1	FSSP0
35	23	IDAC15	IDAC14	IDAC13	IDAC12	IDAC11	IDAC10	IDAC9	IDAC8
36	24	IDAC7	IDAC6	IDAC5	IDAC4	IDAC3	IDAC2	IDAC1	IDAC0
37	25	RSV	IDFS	IDBK	IDSK	IDCH	IDCM	DCAS	IPLK
40	28	RSV	RSV	AFMT1	AFMT0	RSV	RSV	ALEN1	ALEN0
41	29	AOFS7	AOFS6	AOFS5	AOFS4	AOFS3	AOFS2	AOFS1	AOFS0
42	2A	RSV	RSV	AUPL1	AUPL0	RSV	RSV	AUPR1	AUPR0
43	2B	RSV	RSV	RSV	PSEL4	PSEL3	PSEL2	PSEL1	PSEL0
44	2C	RSV	RSV	RSV	RSV	RSV	CMDP2	CMDP1	CMDP0
59	3B	RSV	AMTL2	AMTL1	AMTL0	RSV	AMTR2	AMTR1	AMTR0
60	3C	RSV	RSV	RSV	RSV	RSV	RSV	PCTL1	PCTL0
61	3D	VOLL7	VOLL6	VOLL5	VOLL4	VOLL3	VOLL2	VOLL1	VOLL0
62	3E	VOLR7	VOLR6	VOLR5	VOLR4	VOLR3	VOLR2	VOLR1	VOLR0
63	3F	VNDF1	VNDF0	VNDS1	VNDS0	VNUF1	VNUF0	VNUS1	VNUS0
64	40	VEDF1	VEDF0	VEDS1	VEDS0	RSV	RSV	RSV	RSV
65	41	RSV	RSV	RSV	RSV	RSV	ACTL2	AMLE1	AMRE0
80	50	RSV	RSV	RSV	G1SL4	G1SL3	G1SL2	G1SL1	G1SL0
81	51	RSV	RSV	RSV	G2SL4	G2SL3	G2SL2	G2SL1	G2SL0



**Table 44. Register Map Summary (continued)**

DEC	HEX	B7	B6	B5	B4	B3	B2	B1	B0
82	52	RSV	RSV	RSV	G3SL4	G3SL3	G3SL2	G3SL1	G3SL0
83	53	RSV	RSV	RSV	G4SL4	G4SL3	G4SL2	G4SL1	G4SL0
84	54	RSV	RSV	RSV	G5SL4	G5SL3	G5SL2	G5SL1	G5SL0
85	55	RSV	RSV	RSV	G6SL4	G6SL3	G6SL2	G6SL1	G6SL0
86	56	RSV	RSV	GOUT5	GOUT4	GOUT3	GOUT2	GOUT1	GOUT0
87	57	RSV	RSV	GINV5	GINV4	GINV3	GINV2	GINV1	GINV0
90	5A	RSV	RSV	RSV	L1OV	R1OV	L2OV	R2OV	SFOV
91	5B	RSV	DTFS2	DTFS1	DTFS0	DTSR3	DTSR2	DTSR1	DTSR0
92	5C	RSV	RSV	RSV	RSV	RSV	RSV	RSV	DTBR8
93	5D	DTBR7	DTBR6	DTBR5	DTBR4	DTBR3	DTBR2	DTBR1	DTBR0
94	5E	RSV	CDST	PLL-L	LrckBck	fS-SCKr	SCKval	BCKval	fSval
95	5F	RSV	RSV	RSV	LTSH	RSV	CKMF	CSRF	CERF
108	6C	RSV	RSV	RSV	RSV	RSV	RSV	AMLM	AMRM
109	6D	RSV	RSV	RSV	SDTM	RSV	RSV	RSV	SHTM
114	72	RSV	RSV	RSV	RSV	RSV	RSV	MTST1	MTST0
115	73	RSV	RSV	RSV	RSV	RSV	RSV	FSMM1	FSMM0
118	76	BOTM	RSV	RSV	RSV	PSTM3	PSTM2	PSTM1	PSTM0
119	77	RSV	RSV	GPIN5	GPIN4	GPIN3	GPIN2	GPIN1	RSV
120	78	RSV	RSV	RSV	AMFL	RSV	RSV	RSV	AMFR
121	79	RSV	RSV	RSV	RSV	RSV	RSV	RSV	DAMD
122	7A	RSV	RSV	RSV	RSV	RSV	RSV	RSV	EIFM
123	7B	RSV	G1MC2	G1MC1	G1MC0	RSV	G2MC2	G2MC1	G2MC0
124	7C	RSV	G3MC2	G3MC1	G3MC0	RSV	G4MC2	G4MC1	G4MC0
125	7D	RSV	G5MC2	G5MC1	G5MC0	RSV	G6MC2	G6MC1	G6MC0

**Page 1**

Dec	Hex	b7	b6	b5	b4	b3	b2	b1	b0
1	01	RSV	RSV	RSV	RSV	RSV	RSV	RSV	OSEL
2	02	RSV	RSV	RSV	LAGN	RSV	RSV	RSV	RAGN
5	05	RSV	RSV	RSV	RSV	RSV	RSV	UEPD	UIPD
6	06	RSV	RSV	RSV	RSV	RSV	RSV	RSV	AMCT
7	07	RSV	RSV	RSV	AGBL	RSV	RSV	RSV	AGBR
8	08	RSV	RSV	RSV	RSV	RSV	RSV	RSV	RCMF
9	09	RSV	RSV	RSV	RSV	RSV	RSV	RSV	PCPD

**Page 44**

Dec	Hex	b7	b6	b5	b4	b3	b2	b1	b0
1	01	RSV	RSV	RSV	RSV	ACRM	AMDC	ACRS	ACSW

**Page 253**

Dec	Hex	b7	b6	b5	b4	b3	b2	b1	b0
63	3F	PLLFLEX17	PLLFLEX16	PLLFLEX15	PLLFLEX14	PLLFLEX13	PLLFLEX12	PLLFLEX11	PLLFLEX10
64	40	PLLFLEX27	PLLFLEX26	PLLFLEX25	PLLFLEX24	PLLFLEX23	PLLFLEX22	PLLFLEX21	PLLFLEX20

**13.1.1.2 Page 0 Registers**
**Table 45. Page 0 / Register 1**

Dec	Hex	b7	b6	b5	b4	b3	b2	b1	b0
1	01	RSV	RSV	RSV	RSTM	RSV	RSV	RSV	RSTR
Reset Value					0				0

<b>RSV</b>	<b>Reserved</b> Reserved. Do not access.
<b>RSTM</b>	<b>Reset Modules</b> This bit resets the interpolation filter and the DAC modules. Since the DSP is also reset, the coefficient RAM content will also be cleared by the DSP. This bit is auto cleared and can be set only in standby mode.  Default value: 0 0: Normal 1: Reset modules
<b>RSTR</b>	<b>Reset Registers</b> This bit resets the mode registers back to their initial values. The RAM content is not cleared, but the execution source will be back to ROM. This bit is auto cleared and must be set only when the DAC is in standby mode (resetting registers when the DAC is running is prohibited and not supported).  Default value: 0 0: Normal 1: Reset mode registers

**Table 46. Page 0 / Register 2**

Dec	Hex	b7	b6	b5	b4	b3	b2	b1	b0
<b>2</b>	<b>02</b>	<b>RSV</b>	<b>RSV</b>	<b>RSV</b>	<b>RQST</b>	<b>RSV</b>	<b>RSV</b>	<b>RSV</b>	<b>RQPD</b>
Reset Value					0				0

<b>RSV</b>	<b>Reserved</b> Reserved. Do not access.
<b>RQST</b>	<b>Standby Request</b> When this bit is set, the DAC will be forced into a system standby mode, which is also the mode the system enters in the case of clock errors. In this mode, most subsystems will be powered down but the charge pump and digital power supply.  Default value: 0 0: Normal operation 1: Standby mode
<b>RQPD</b>	<b>Powerdown Request</b> When this bit is set, the DAC will be forced into powerdown mode, in which the power consumption would be minimum as the charge pump is also powered down. However, it will take longer to restart from this mode. This mode has higher precedence than the standby mode, that is, setting this bit along with bit 4 for standby mode will result in the DAC going into powerdown mode.  Default value: 0 0: Normal operation 1: Powerdown mode

**Table 47. Page 0 / Register 3**

Dec	Hex	b7	b6	b5	b4	b3	b2	b1	b0
<b>3</b>	<b>03</b>	<b>RSV</b>	<b>RSV</b>	<b>RSV</b>	<b>RQML</b>	<b>RSV</b>	<b>RSV</b>	<b>RSV</b>	<b>RQMR</b>
Reset Value					0				0

<b>RSV</b>	<b>Reserved</b> Reserved. Do not access.
<b>RQML</b>	<b>Mute Left Channel</b> This bit issues soft mute request for the left channel. The volume will be smoothly ramped down/up to avoid pop/click noise.  Default value: 0 0: Normal volume 1: Mute

<b>RQMR</b>	<p><b>Mute Right Channel</b></p> <p>This bit issues soft mute request for the right channel. The volume will be smoothly ramped down/up to avoid pop/click noise.</p> <p style="padding-left: 40px;">Default value: 0</p> <p style="padding-left: 40px;">0: Normal volume</p> <p style="padding-left: 40px;">1: Mute</p>
-------------	--

**Table 48. Page 0 / Register 4**

Dec	Hex	b7	b6	b5	b4	b3	b2	b1	b0
4	04	RSV	RSV	RSV	PLCK	RSV	RSV	RSV	PLLE
Reset Value									1

<b>RSV</b>	<p><b>Reserved</b></p> <p>Reserved. Do not access.</p>
<b>PLCK</b>	<p><b>PLL Lock Flag (Read Only)</b></p> <p>This bit indicates whether the PLL is locked or not. When the PLL is disabled this bit always shows that the PLL is not locked.</p> <p style="padding-left: 40px;">0: The PLL is locked</p> <p style="padding-left: 40px;">1: The PLL is not locked</p>
<b>PLLE</b>	<p><b>PLL Enable</b></p> <p>This bit enables or disables the internal PLL. When PLL is disabled, the master clock will be switched to the SCK.</p> <p style="padding-left: 40px;">Default value: 1</p> <p style="padding-left: 40px;">0: Disable PLL</p> <p style="padding-left: 40px;">1: Enable PLL</p>

**Table 49. Page 0 / Register 6**

Dec	Hex	b7	b6	b5	b4	b3	b2	b1	b0
6	06	RSV	RSV	RSV	RSV	RSV	RSV	FSMI1	FSMI0
Reset Value								0	0

<b>RSV</b>	<p><b>Reserved</b></p> <p>Reserved. Do not access.</p>
<b>FSMI[1:0]</b>	<p><b>SPI MISO function sel</b></p> <p>These bits select the function of the SPI_MISO pin when in SPI mode. If the pin is set as GPIO, register readout via SPI is not possible.</p> <p style="padding-left: 40px;">Default value: 00</p> <p style="padding-left: 40px;">00: SPI_MISO</p> <p style="padding-left: 40px;">01: GPIO1</p> <p style="padding-left: 40px;">Others: Reserved (Do not set)</p>

**Table 50. Page 0 / Register 7**

Dec	Hex	b7	b6	b5	b4	b3	b2	b1	b0
7	07	RSV	RSV	RSV	DEMP	RSV	RSV	RSV	SDSL
Reset Value					0				0

<b>RSV</b>	<p><b>Reserved</b></p> <p>Reserved. Do not access.</p>
<b>DEMP</b>	<p><b>De-Emphasis Enable</b></p> <p>This bit enables or disables the de-emphasis filter. The default coefficients are for 44.1kHz sampling rate, but can be changed by reprogramming the appropriate coefficients in RAM.</p>

	Default value: 0 0: De-emphasis filter is disabled 1: De-emphasis filter is enabled
<b>SDSL</b>	<b>SDOUT Select</b> This bit selects what is being output as SDOOUT via GPIO pins. Default value: 0 0: SDOOUT is the DSP output (post-processing) 1: SDOOUT is the DSP input (pre-processing)

**Table 51. Page 0 / Register 8**

Dec	Hex	b7	b6	b5	b4	b3	b2	b1	b0
<b>8</b>	<b>08</b>	<b>RSV</b>	<b>RSV</b>	<b>G6OE</b>	<b>G5OE</b>	<b>G4OE</b>	<b>G3OE</b>	<b>G2OE</b>	<b>G1OE</b>
Reset Value				0	0	0	0	0	0

<b>RSV</b>	<b>Reserved</b> Reserved. Do not access.
<b>G6OE</b>	<b>GPIO6 Output Enable</b> This bit sets the direction of the GPIO6 pin Default value: 0 0: GPIO6 is input 1: GPIO6 is output
<b>G5OE</b>	<b>GPIO5 Output Enable</b> This bit sets the direction of the GPIO5 pin Default value: 0 0: GPIO5 is input 1: GPIO5 is output
<b>G4OE</b>	<b>GPIO4 Output Enable</b> This bit sets the direction of the GPIO4 pin Default value: 0 0: GPIO4 is input 1: GPIO4 is output
<b>G3OE</b>	<b>GPIO3 Output Enable</b> This bit sets the direction of the GPIO3 pin Default value: 0 0: GPIO3 is input 1: GPIO3 is output
<b>G2OE</b>	<b>GPIO2 Output Enable</b> This bit sets the direction of the GPIO2 pin Default value: 0 0: GPIO2 is input 1: GPIO2 is output
<b>G1OE</b>	<b>GPIO1 Output Enable</b> This bit sets the direction of the GPIO1 pin Default value: 0 0: GPIO1 is input 1: GPIO1 is output

**Table 52. Page 0 / Register 9**

Dec	Hex	b7	b6	b5	b4	b3	b2	b1	b0
9	09	RSV	RSV	BCKP	BCKO	RSV	RSV	RSV	LRKO
Reset Value				0	0				0

<b>RSV</b>	<b>Reserved</b> Reserved. Do not access.
<b>BCKP</b>	<b>BCK Polarity</b> This bit sets the inverted BCK mode. In inverted BCK mode, the DAC assumes that the LRCK and DIN edges are aligned to the rising edge of the BCK. Normally they are assumed to be aligned to the falling edge of the BCK.  Default value: 0 0: Normal BCK mode 1: Inverted BCK mode
<b>BCKO</b>	<b>BCK Output Enable</b> This bit sets the BCK pin direction to output for I2S master mode operation. In I2S master mode the PCM5xxx outputs the reference BCK and LRCK, and the external source device provides the DIN according to these clocks. Use Page 0 / Register 32 to program the division factor of the SCK to yield the desired BCK rate (normally 64FS)  Default value: 0 0: BCK is input (I2S slave mode) 1: BCK is output (I2S master mode)
<b>LRKO</b>	<b>LRCLK Output Enable</b> This bit sets the LRCK pin direction to output for I2S master mode operation. In I2S master mode the PCM5xxx outputs the reference BCK and LRCK, and the external source device provides the DIN according to these clocks. Use Page 0 / Register 33 to program the division factor of the BCK to yield 1FS for LRCK.  Default value: 0 0: LRCK is input (I2S slave mode) 1: LRCK is output (I2S master mode)

**Table 53. Page 0 / Register 10**

Dec	Hex	b7	b6	b5	b4	b3	b2	b1	b0
10	0A	DSPG7	DSPG6	DSPG5	DSPG4	DSPG3	DSPG2	DSPG1	DSPG0
Reset Value		0	0	0	0	0	0	0	0

<b>DSPG[7:0]</b>	<b>DSP GPIO Input</b> The DSP accepts a 24-bit external control signals input. The value set in this register will go to bit 16:8 of this external input.  Default value: 00000000
------------------	---

**Table 54. Page 0 / Register 12**

Dec	Hex	b7	b6	b5	b4	b3	b2	b1	b0
12	0C	RSV	RSV	RSV	RSV	RSV	RSV	RBCK	RLRK
Reset Value								0	0

<b>RSV</b>	<b>Reserved</b> Reserved. Do not access.
<b>RBCK</b>	<b>Master Mode BCK Divider Reset</b> This bit, when set to 0, will reset the SCK divider to generate BCK clock for I2S master mode. To use I2S master mode, the divider must be enabled and programmed properly.  Default value: 0 0: Master mode BCK clock divider is reset

	1: Master mode BCK clock divider is functional
<b>RLRK</b>	<b>Master Mode LRCK Divider Reset</b> This bit, when set to 0, will reset the BCK divider to generate LRCK clock for I2S master mode. To use I2S master mode, the divider must be enabled and programmed properly. Default value: 0 0: Master mode LRCK clock divider is reset 1: Master mode LRCK clock divider is functional

**Table 55. Page 0 / Register 13**

Dec	Hex	b7	b6	b5	b4	b3	b2	b1	b0
<b>13</b>	<b>0D</b>	<b>RSV</b>	<b>SREF2</b>	<b>SREF1</b>	<b>SREF0</b>	<b>RSV</b>	<b>RSV</b>	<b>RSV</b>	<b>RSV</b>
Reset Value			0	0	0				

<b>RSV</b>	<b>Reserved</b> Reserved. Do not access.
<b>SREF[2:0]</b>	<b>PLL Reference</b> This bit select the source clock for internal PLL. This bit is ignored and overridden in clock auto set mode. Default value: 000 000: The PLL reference clock is SCK 001: The PLL reference clock is BCK 010: Reserved 011: The PLL reference clock is GPIO (selected using Page 0 / Register 18) others: Reserved (PLL reference is muted)
<b>SREF</b>	<b>PLL Reference</b> Default value: 0

**Table 56. Page 0 / Register 14**

Dec	Hex	b7	b6	b5	b4	b3	b2	b1	b0
<b>14</b>	<b>0E</b>	<b>RSV</b>	<b>SDAC2</b>	<b>SDAC1</b>	<b>SDAC0</b>	<b>RSV</b>	<b>RSV</b>	<b>RSV</b>	<b>RSV</b>
Reset Value			0	0	0				

<b>RSV</b>	<b>Reserved</b> Reserved. Do not access.
<b>SDAC[2:0]</b>	<b>DAC clock source</b> These bits select the source clock for DAC clock divider. Default value: 000 This Register requires use of the Clock Flex Register 000: Master clock (PLL/SCK and OSC auto-select) 001: PLL clock 010: Reserved 011: SCK clock 100: BCK clock others: Reserved (muted)

**Table 57. Page 0 / Register 18**

Dec	Hex	b7	b6	b5	b4	b3	b2	b1	b0
<b>18</b>	<b>12</b>	<b>RSV</b>	<b>RSV</b>	<b>RSV</b>	<b>RSV</b>	<b>RSV</b>	<b>GREF2</b>	<b>GREF1</b>	<b>GREF0</b>
Reset Value							0	0	0

<b>RSV</b>	<b>Reserved</b> Reserved. Do not access.
<b>GREF[2:0]</b>	<b>GPIO Source for PLL reference clk</b> These bits select the GPIO pins as clock input source when GPIO is selected as the PLL reference clock source.  Default value: 000 This register requires use of the Clock Flex Register.000: GPIO1 001: GPIO2 010: GPIO3 011: GPIO4 100: GPIO5 101: GPIO6 others: Reserved (muted)

**Table 58. Page 0 / Register 19**

Dec	Hex	b7	b6	b5	b4	b3	b2	b1	b0
19	13	RSV	RSV	RSV	RSV	RSV	RSV	RSV	RQSY
Reset Value									0

<b>RSV</b>	<b>Reserved</b> Reserved. Do not access.
<b>RQSY</b>	<b>Sync request</b> This bit, when set to 1 will issue the clock resynchronization by synchronously resets the DAC, CP and OSR clocks. The actual clock resynchronization takes place when this bit is set back to 0, where the DAC, CP and OSR clocks are resumed at the beginning of the audio frame.  Default value: 0 0: Resume DAC, CP and OSR clocks synchronized to the beginning of audio frame 1: Halt DAC, CP and OSR clocks as the beginning of resynchronization process

**Table 59. Page 0 / Register 20**

Dec	Hex	b7	b6	b5	b4	b3	b2	b1	b0
20	14	RSV	RSV	RSV	RSV	PPDV3	PPDV2	PPDV1	PPDV0
Reset Value						0	0	0	0

<b>RSV</b>	<b>Reserved</b> Reserved. Do not access.
<b>PPDV[3:0]</b>	<b>PLL P</b> These bits set the PLL divider P factor. These bits are ignored in clock auto set mode.  Default value: 0000 0000: P=1 0001: P=2 ... 1110: P=15 1111: Prohibited (do not set this value)

**Table 60. Page 0 / Register 21**

Dec	Hex	b7	b6	b5	b4	b3	b2	b1	b0
21	15	RSV	RSV	PJDV5	PJDV4	PJDV3	PJDV2	PJDV1	PJDV0
Reset Value				0	0	0	0	0	0

<b>RSV</b>	<b>Reserved</b> Reserved. Do not access.
<b>PJDV[5:0]</b>	<b>PLL J</b> These bits set the J part of the overall PLL multiplication factor J.D * R. These bits are ignored in clock auto set mode.  Default value: 000000 000000: Prohibited (do not set this value) 000001: J=1 000010: J=2 ... 111111: J=63

**Table 61. Page 0 / Register 22**

Dec	Hex	b7	b6	b5	b4	b3	b2	b1	b0
22	16	RSV	RSV	PDDV13	PDDV12	PDDV11	PDDV10	PDDV9	PDDV8
Reset Value				0	0	0	0	0	0

**Table 62. Page 0 / Register 23**

Dec	Hex	b7	b6	b5	b4	b3	b2	b1	b0
23	17	PDDV7	PDDV6	PDDV5	PDDV4	PDDV3	PDDV2	PDDV1	PDDV0
Reset Value		0	0	0	0	0	0	0	0

<b>RSV</b>	<b>Reserved</b> Reserved. Do not access.
<b>PDDV[13:0]</b>	<b>PLL D (MSB)</b> These bits set the D part of the overall PLL multiplication factor J.D * R. These bits are ignored in clock auto set mode.  Default value: 0000000000000000 0 (in decimal): D=0000 1 (in decimal): D=0001 ... 9999 (in decimal): D=9999 others: Prohibited (do not set)

**Table 63. Page 0 / Register 24**

Dec	Hex	b7	b6	b5	b4	b3	b2	b1	b0
24	18	RSV	RSV	RSV	RSV	PRDV3	PRDV2	PRDV1	PRDV0
Reset Value						0	0	0	0

<b>RSV</b>	<b>Reserved</b> Reserved. Do not access.
<b>PRDV[3:0]</b>	<b>PLL R</b> These bits set the R part of the overall PLL multiplication factor J.D * R. These bits are ignored in clock auto set mode.  Default value: 0000 0000: R=1 0001: R=2 ... 1111: R=16



**Table 64. Page 0 / Register 27**

Dec	Hex	b7	b6	b5	b4	b3	b2	b1	b0
27	1B	RSV	DDSP6	DDSP5	DDSP4	DDSP3	DDSP2	DDSP1	DDSP0
Reset Value			0	0	0	0	0	0	0

<b>RSV</b>	<b>Reserved</b> Reserved. Do not access.
<b>DDSP[6:0]</b>	<b>DSP Clock Divider</b> These bits set the source clock divider value for the DSP clock. These bits are ignored in clock auto set mode. Default value: 0000000 0000000: Divide by 1 0000001: Divide by 2 ... 1111111: Divide by 128

**Table 65. Page 0 / Register 28**

Dec	Hex	b7	b6	b5	b4	b3	b2	b1	b0
28	1C	RSV	DDAC6	DDAC5	DDAC4	DDAC3	DDAC2	DDAC1	DDAC0
Reset Value			0	0	0	0	0	0	0

<b>RSV</b>	<b>Reserved</b> Reserved. Do not access.
<b>DDAC[6:0]</b>	<b>DAC Clock Divider</b> These bits set the source clock divider value for the DAC clock. These bits are ignored in clock auto set mode. Default value: 0000000 0000000: Divide by 1 0000001: Divide by 2 ... 1111111: Divide by 128

**Table 66. Page 0 / Register 29**

Dec	Hex	b7	b6	b5	b4	b3	b2	b1	b0
29	1D	RSV	DNCP6	DNCP5	DNCP4	DNCP3	DNCP2	DNCP1	DNCP0
Reset Value			0	0	0	0	0	0	0

<b>RSV</b>	<b>Reserved</b> Reserved. Do not access.
<b>DNCP[6:0]</b>	<b>NCP Clock Divider</b> These bits set the source clock divider value for the CP clock. These bits are ignored in clock auto set mode. Default value: 0000000 0000000: Divide by 1 0000001: Divide by 2 ... 1111111: Divide by 128

**Table 67. Page 0 / Register 30**

Dec	Hex	b7	b6	b5	b4	b3	b2	b1	b0
30	1E	RSV	DOSR6	DOSR5	DOSR4	DOSR3	DOSR2	DOSR1	DOSR0
Reset Value			0	0	0	0	0	0	0

<b>RSV</b>	<b>Reserved</b> Reserved. Do not access.
<b>DOSR[6:0]</b>	<b>OSR Clock Divider</b> These bits set the source clock divider value for the OSR clock. These bits are ignored in clock auto set mode. Default value: 0000000 0000000: Divide by 1 0000001: Divide by 2 ... 1111111: Divide by 128

**Table 68. Page 0 / Register 32**

Dec	Hex	b7	b6	b5	b4	b3	b2	b1	b0
<b>32</b>	<b>20</b>	<b>RSV</b>	<b>DBCK6</b>	<b>DBCK5</b>	<b>DBCK4</b>	<b>DBCK3</b>	<b>DBCK2</b>	<b>DBCK1</b>	<b>DBCK0</b>
Reset Value			0	0	0	0	0	0	0

<b>RSV</b>	<b>Reserved</b> Reserved. Do not access.
<b>DBCK[6:0]</b>	<b>Master Mode BCK Divider</b> These bits set the SCK divider value to generate I2S master BCK clock. Default value: 0000000 0000000: Divide by 1 0000001: Divide by 2 ... 1111111: Divide by 128

**Table 69. Page 0 / Register 33**

Dec	Hex	b7	b6	b5	b4	b3	b2	b1	b0
<b>33</b>	<b>21</b>	<b>DLRK7</b>	<b>DLRK6</b>	<b>DLRK5</b>	<b>DLRK4</b>	<b>DLRK3</b>	<b>DLRK2</b>	<b>DLRK1</b>	<b>DLRK0</b>
Reset Value		0	0	0	0	0	0	0	0

<b>DLRK[7:0]</b>	<b>Master Mode LRCK Divider</b> These bits set the I2S master BCK clock divider value to generate I2S master LRCK clock. Default value: 00000000 00000000: Divide by 1 00000001: Divide by 2 ... 11111111: Divide by 256
------------------	--

**Table 70. Page 0 / Register 34**

Dec	Hex	b7	b6	b5	b4	b3	b2	b1	b0
<b>34</b>	<b>22</b>	<b>RSV</b>	<b>RSV</b>	<b>RSV</b>	<b>I16E</b>	<b>RSV</b>	<b>RSV</b>	<b>FSSP1</b>	<b>FSSP0</b>
Reset Value					0			0	0

<b>RSV</b>	<b>Reserved</b> Reserved. Do not access.
<b>I16E</b>	<b>16x Interpolation</b> This bit enables or disables the 16x interpolation mode Default value: 0 0: 8x interpolation

	1: 16x interpolation
<b>FSSP[1:0]</b>	<p><b>FS Speed Mode</b></p> <p>These bits select the FS operation mode, which must be set according to the current audio sampling rate. These bits are ignored in clock auto set mode.</p> <p>Default value: 00</p> <p>00: Single speed (FS ≤ 48 kHz)</p> <p>01: Double speed (48 kHz &lt; FS ≤ 96 kHz)</p> <p>10: Quad speed (96 kHz &lt; FS ≤ 192 kHz)</p> <p>11: Octal speed (192 kHz &lt; FS ≤ 384 kHz)</p>

**Table 71. Page 0 / Register 35**

Dec	Hex	b7	b6	b5	b4	b3	b2	b1	b0
35	23	IDAC15	IDAC14	IDAC13	IDAC12	IDAC11	IDAC10	IDAC9	IDAC8
Reset Value		0	0	0	0	0	0	0	1

**Table 72. Page 0 / Register 36**

Dec	Hex	b7	b6	b5	b4	b3	b2	b1	b0
36	24	IDAC7	IDAC6	IDAC5	IDAC4	IDAC3	IDAC2	IDAC1	IDAC0
Reset Value		0	0	0	0	0	0	0	0

<b>IDAC[15:0]</b>	<p><b>IDAC (MSB)</b></p> <p>These bits specify the number of DSP clock cycles available in one audio frame. The value should match the DSP clock FS ratio. These bits are ignored in clock auto set mode.</p> <p>Default value: 0000000100000000</p>
-------------------	--

**Table 73. Page 0 / Register 37**

Dec	Hex	b7	b6	b5	b4	b3	b2	b1	b0
37	25	RSV	IDFS	IDBK	IDSK	IDCH	IDCM	DCAS	IPLK
Reset Value			0	0	0	0	0	0	0

<b>RSV</b>	<p><b>Reserved</b></p> <p>Reserved. Do not access.</p>
<b>IDFS</b>	<p><b>Ignore FS Detection</b></p> <p>This bit controls whether to ignore the FS detection. When ignored, FS error will not cause a clock error.</p> <p>Default value: 0</p> <p>0: Regard FS detection</p> <p>1: Ignore FS detection</p>
<b>IDBK</b>	<p><b>Ignore BCK Detection</b></p> <p>This bit controls whether to ignore the BCK detection against LRCK. The BCK must be stable between 32FS and 256FS inclusive or an error will be reported. When ignored, a BCK error will not cause a clock error.</p> <p>Default value: 0</p> <p>0: Regard BCK detection</p> <p>1: Ignore BCK detection</p>
<b>IDSK</b>	<p><b>Ignore SCK Detection</b></p> <p>This bit controls whether to ignore the SCK detection against LRCK. Only some certain SCK ratios within some error margin are allowed. When ignored, an SCK error will not cause a clock error.</p> <p>Default value: 0</p> <p>0: Regard SCK detection</p> <p>1: Ignore SCK detection</p>
<b>IDCH</b>	<p><b>Ignore Clock Halt Detection</b></p>

	<p>This bit controls whether to ignore the SCK halt (static or frequency is lower than acceptable) detection. When ignored an SCK halt will not cause a clock error.</p> <p>Default value: 0</p> <p>0: Regard SCK halt detection</p> <p>1: Ignore SCK halt detection</p>
<b>IDCM</b>	<p><b>Ignore LRCK/BCK Missing Detection</b></p> <p>This bit controls whether to ignore the LRCK/BCK missing detection. The LRCK/BCK need to be in low state (not only static) to be deemed missing. When ignored an LRCK/BCK missing will not cause the DAC go into powerdown mode.</p> <p>Default value: 0</p> <p>0: Regard LRCK/BCK missing detection</p> <p>1: Ignore LRCK/BCK missing detection</p>
<b>DCAS</b>	<p><b>Disable Clock Divider Autose</b></p> <p>This bit enables or disables the clock auto set mode. When dealing with uncommon audio clock configuration, the auto set mode must be disabled and all clock dividers must be set manually. Additionally, some clock detectors might also need to be disabled. The clock autose feature will not work with PLL enabled in VCOM mode. In this case this feature has to be disabled and the clock dividers must be set manually.</p> <p>Default value: 0</p> <p>0: Enable clock auto set</p> <p>1: Disable clock auto set</p>
<b>IPLK</b>	<p><b>Ignore PLL Lock Detection</b></p> <p>This bit controls whether to ignore the PLL lock detection. When ignored, PLL unlocks will not cause a clock error. The PLL lock flag at Page 0 / Register 4, bit 4 is always correct regardless of this bit.</p> <p>Default value: 0</p> <p>0: PLL unlocks raise clock error</p> <p>1: PLL unlocks are ignored</p>

**Table 74. Page 0 / Register 40**

Dec	Hex	b7	b6	b5	b4	b3	b2	b1	b0
40	28	RSV	RSV	AFMT1	AFMT0	RSV	RSV	ALEN1	ALEN0
Reset Value				0	0			1	0

<b>RSV</b>	<p><b>Reserved</b></p> <p>Reserved. Do not access.</p>
<b>AFMT[1:0]</b>	<p><b>I2S Data Format</b></p> <p>These bits control both input and output audio interface formats for DAC operation.</p> <p>Default value: 00</p> <p>00: I2S</p> <p>01: TDM/DSP</p> <p>10: RTJ</p> <p>11: LTJ</p>
<b>ALEN[1:0]</b>	<p><b>I2S Word Length</b></p> <p>These bits control both input and output audio interface sample word lengths for DAC operation.</p> <p>Default value: 10</p> <p>00: 16 bits</p> <p>01: 20 bits</p> <p>10: 24 bits</p> <p>11: 32 bits</p>

**Table 75. Page 0 / Register 41**

Dec	Hex	b7	b6	b5	b4	b3	b2	b1	b0
41	29	AOFS7	AOFS6	AOFS5	AOFS4	AOFS3	AOFS2	AOFS1	AOFS0
Reset Value		0	0	0	0	0	0	0	0

<b>AOFS[7:0]</b>	<b>I2S Shift</b> These bits control the offset of audio data in the audio frame for both input and output. The offset is defined as the number of BCK from the starting (MSB) of audio frame to the starting of the desired audio sample. Default value: 00000000 00000000: offset = 0 BCK (no offset) 00000001: offset = 1 BCK 00000010: offset = 2 BCKs ... 11111111: offset = 256 BCKs
------------------	--

**Table 76. Page 0 / Register 42**

Dec	Hex	b7	b6	b5	b4	b3	b2	b1	b0
42	2A	RSV	RSV	AUPL1	AUPL0	RSV	RSV	AUPR1	AUPR0
Reset Value				0	1			0	1

<b>RSV</b>	<b>Reserved</b> Reserved. Do not access.
<b>AUPL[1:0]</b>	<b>Left DAC Data Path</b> These bits control the left channel audio data path connection. Default value: 01 00: Zero data (mute) 01: Left channel data 10: Right channel data 11: Reserved (do not set)
<b>AUPR[1:0]</b>	<b>Right DAC Data Path</b> These bits control the right channel audio data path connection. Default value: 01 00: Zero data (mute) 01: Right channel data 10: Left channel data 11: Reserved (do not set)

**Table 77. Page 0 / Register 43**

Dec	Hex	b7	b6	b5	b4	b3	b2	b1	b0
43	2B	RSV	RSV	RSV	PSEL4	PSEL3	PSEL2	PSEL1	PSEL0
Reset Value					0	0	0	0	1

<b>RSV</b>	<b>Reserved</b> Reserved. Do not access.
<b>PSEL[4:0]</b>	<b>DSP Program Selection</b> These bits select the DSP program to use for audio processing. Default value: 00001 00000: Reserved (do not set) 00001: 8x/4x/2x FIR interpolation filter with de-emphasis 00010: 8x/4x/2x Low latency IIR interpolation filter with de-emphasis

	00011: High attenuation x8/x4/x2 interpolation filter with de-emphasis 00100: Reserved 00101: Fixed process flow with configurable parameters 00110: Reserved (do not set) 00111: 8x Ringing-less low latency FIR interpolation filter without de-emphasis 11111: others: Reserved (do not set)
--	---

**Table 78. Page 0 / Register 44**

Dec	Hex	b7	b6	b5	b4	b3	b2	b1	b0
44	2C	RSV	RSV	RSV	RSV	RSV	CMDP2	CMDP1	CMDP0
Reset Value							0	0	0

<b>RSV</b>	<b>Reserved</b> Reserved. Do not access.
<b>CMDP[2:0]</b>	<b>Clock Missing Detection Period</b> These bits set how long both BCK and LRCK keep low before the audio clocks deemed missing and the DAC transitions to powerdown mode. Default value: 000 000: about 1 second 001: about 2 seconds 010: about 3 seconds ... 111: about 8 seconds

**Table 79. Page 0 / Register 59**

Dec	Hex	b7	b6	b5	b4	b3	b2	b1	b0
59	3B	RSV	AMTL2	AMTL1	AMTL0	RSV	AMTR2	AMTR1	AMTR0
Reset Value			0	0	0		0	0	0

<b>RSV</b>	<b>Reserved</b> Reserved. Do not access.
<b>AMTL[2:0]</b>	<b>Auto Mute Time for Left Channel</b> These bits specify the length of consecutive zero samples at left channel before the channel can be auto muted. The times shown are for 48 kHz sampling rate and will scale with other rates. Default value: 000 000: 21 ms 001: 106 ms 010: 213 ms 011: 533 ms 100: 1.07 sec 101: 2.13 sec 110: 5.33 sec 111: 10.66 sec
<b>AMTR[2:0]</b>	<b>Auto Mute Time for Right Channel</b> These bits specify the length of consecutive zero samples at right channel before the channel can be auto muted. The times shown are for 48 kHz sampling rate and will scale with other rates. Default value: 000 000: 21 ms 001: 106 ms

	010: 213 ms 011: 533 ms 100: 1.07 sec 101: 2.13 sec 110: 5.33 sec 111: 10.66 sec
--	---

**Table 80. Page 0 / Register 60**

Dec	Hex	b7	b6	b5	b4	b3	b2	b1	b0
60	3C	RSV	RSV	RSV	RSV	RSV	RSV	PCTL1	PCTL0
Reset Value								0	0

<b>RSV</b>	<b>Reserved</b> Reserved. Do not access.
<b>PCTL[1:0]</b>	<b>Digital Volume Control</b> These bits control the behavior of the digital volume. Default value: 00 00: The volume for Left and right channels are independent 01: Right channel volume follows left channel setting 10: Left channel volume follows right channel setting 11: Reserved (The volume for Left and right channels are independent)

**Table 81. Page 0 / Register 61**

Dec	Hex	b7	b6	b5	b4	b3	b2	b1	b0
61	3D	VOLL7	VOLL6	VOLL5	VOLL4	VOLL3	VOLL2	VOLL1	VOLL0
Reset Value		0	0	1	1	0	0	0	0

<b>VOLL[7:0]</b>	<b>Left Digital Volume</b> These bits control the left channel digital volume. The digital volume is 24 dB to -103 dB in -0.5 dB step. Default value: 00110000 00000000: +24.0 dB 00000001: +23.5 dB ... 00101111: +0.5 dB 00110000: 0.0 dB 00110001: -0.5 dB ... 11111110: -103 dB 11111111: Mute
------------------	---

**Table 82. Page 0 / Register 62**

Dec	Hex	b7	b6	b5	b4	b3	b2	b1	b0
62	3E	VOLR7	VOLR6	VOLR5	VOLR4	VOLR3	VOLR2	VOLR1	VOLR0
Reset Value		0	0	1	1	0	0	0	0

<b>VOLR[7:0]</b>	<b>Right Digital Volume</b> These bits control the right channel digital volume. The digital volume is 24 dB to -103 dB in -0.5 dB step. Default value: 00110000 00000000: +24.0 dB
------------------	--

	00000001: +23.5 dB ... 00101111: +0.5 dB 00110000: 0.0 dB 00110001: -0.5 dB ... 11111110: -103 dB 11111111: Mute
--	---

**Table 83. Page 0 / Register 63**

Dec	Hex	b7	b6	b5	b4	b3	b2	b1	b0
63	3F	VNDF1	VNDF0	VNDS1	VNDS0	VNUF1	VNUF0	VNUS1	VNUS0
Reset Value		0	0	1	0	0	0	1	0

<b>VNDF[1:0]</b>	<b>Digital Volume Normal Ramp Down Frequency</b> These bits control the frequency of the digital volume updates when the volume is ramping down. The setting here is applied to soft mute request, asserted by XSMUTE pin or Page 0 / Register 3. Default value: 00 00: Update every 1 FS period 01: Update every 2 FS periods 10: Update every 4 FS periods 11: Directly set the volume to zero (Instant mute)
<b>VNDS[1:0]</b>	<b>Digital Volume Normal Ramp Down Step</b> These bits control the step of the digital volume updates when the volume is ramping down. The setting here is applied to soft mute request, asserted by XSMUTE pin or Page 0 / Register 3. Default value: 10 00: Decrement by 4 dB for each update 01: Decrement by 2 dB for each update 10: Decrement by 1 dB for each update 11: Decrement by 0.5 dB for each update
<b>VNUF[1:0]</b>	<b>Digital Volume Normal Ramp Up Frequency</b> These bits control the frequency of the digital volume updates when the volume is ramping up. The setting here is applied to soft unmute request, asserted by XSMUTE pin or Page 0 / Register 3. Default value: 00 00: Update every 1 FS period 01: Update every 2 FS periods 10: Update every 4 FS periods 11: Directly restore the volume (Instant unmute)
<b>VNUS[1:0]</b>	<b>Digital Volume Normal Ramp Up Step</b> These bits control the step of the digital volume updates when the volume is ramping up. The setting here is applied to soft unmute request, asserted by XSMUTE pin or Page 0 / Register 3. Default value: 10 00: Increment by 4 dB for each update 01: Increment by 2 dB for each update 10: Increment by 1 dB for each update 11: Increment by 0.5 dB for each update

**Table 84. Page 0 / Register 64**

Dec	Hex	b7	b6	b5	b4	b3	b2	b1	b0
64	40	VEDF1	VEDF0	VEDS1	VEDS0	RSV	RSV	RSV	RSV
Reset Value		0	0	0	0				



<b>RSV</b>	<b>Reserved</b> Reserved. Do not access.
<b>VEDF[1:0]</b>	<b>Digital Volume Emergency Ramp Down Frequency</b> These bits control the frequency of the digital volume updates when the volume is ramping down due to clock error or power outage, which usually needs faster ramp down compared to normal soft mute.  Default value: 00 00: Update every 1 FS period 01: Update every 2 FS periods 10: Update every 4 FS periods 11: Directly set the volume to zero (Instant mute)
<b>VEDS[1:0]</b>	<b>Digital Volume Emergency Ramp Down Step</b> These bits control the step of the digital volume updates when the volume is ramping down due to clock error or power outage, which usually needs faster ramp down compared to normal soft mute.  Default value: 00 00: Decrement by 4 dB for each update 01: Decrement by 2 dB for each update 10: Decrement by 1 dB for each update 11: Decrement by 0.5 dB for each update

**Table 85. Page 0 / Register 65**

Dec	Hex	b7	b6	b5	b4	b3	b2	b1	b0
65	41	RSV	RSV	RSV	RSV	RSV	ACTL2	AMLE1	AMRE0
Reset Value							1	1	1

<b>RSV</b>	<b>Reserved</b> Reserved. Do not access.
<b>ACTL[2:0]</b>	<b>Auto Mute Control</b> This bit controls the behavior of the auto mute upon zero sample detection. The time length for zero detection is set with Page 0 / Register 59.  Default value: 111 0: Auto mute left channel and right channel independently. 1: Auto mute left and right channels only when both channels are about to be auto muted.
<b>AMLE[1:0]</b>	<b>Auto Mute Left Channel</b> This bit enables or disables auto mute on right channel. Note that when right channel auto mute is disabled and the Page 0 / Register 65, bit 2 is set to 1, the left channel will also never be auto muted.  Default value: 11 0: Disable right channel auto mute 1: Enable right channel auto mute
<b>AMRE</b>	<b>Auto Mute Right Channel</b> This bit enables or disables auto mute on left channel. Note that when left channel auto mute is disabled and the Page 0 / Register 65, bit 2 is set to 1, the right channel will also never be auto muted.  Default value: 1 0: Disable left channel auto mute 1: Enable left channel auto mute

**Table 86. Page 0 / Register 80**

Dec	Hex	b7	b6	b5	b4	b3	b2	b1	b0
80	50	RSV	RSV	RSV	G1SL4	G1SL3	G1SL2	G1SL1	G1SL0
Reset Value					0	0	0	0	0

<b>RSV</b>	<b>Reserved</b> Reserved. Do not access.
<b>G1SL[4:0]</b>	<b>GPIO1 Output Selection</b> These bits select the signal to output to GPIO1. To actually output the selected signal, the GPIO1 must be set to output mode at Page 0 / Register 8. Default value: 00000 00000: off (low) 00001: DSP GPIO1 output 00010: Register GPIO1 output (Page 0 / Register 86, bit 0) 00011: Auto mute flag (asserted when both L and R channels are auto muted) 00100: Auto mute flag for left channel 00101: Auto mute flag for right channel 00110: Clock invalid flag (clock error or clock changing or clock missing) 00111: Serial audio interface data output (SDOUT) 01000: Analog mute flag for left channel (low active) 01001: Analog mute flag for right channel (low active) 01010: PLL lock flag 01011: Charge pump clock 01100: Reserved 01101: Reserved 01110: Under voltage flag, asserted when XSMUTE voltage is higher than 0.7 DVDD 01111: Under voltage flag, asserted when XSMUTE voltage is higher than 0.3 DVDD 010000: PLL Output/4 (Requires Clock Flex Register) OTHERS: RESERVED

**Table 87. Page 0 / Register 81**

Dec	Hex	b7	b6	b5	b4	b3	b2	b1	b0
81	51	RSV	RSV	RSV	G2SL4	G2SL3	G2SL2	G2SL1	G2SL0
Reset Value					0	0	0	0	0

<b>RSV</b>	<b>Reserved</b> Reserved. Do not access.
<b>G2SL[4:0]</b>	<b>GPIO2 Output Selection</b> These bits select the signal to output to GPIO2. To actually output the selected signal, the GPIO2 must be set to output mode at Page 0 / Register 8. Default value: 00000 00000: off (low) 00001: DSP GPIO2 output 00010: Register GPIO2 output (Page 0 / Register 86, bit 1) 00011: Auto mute flag (asserted when both L and R channels are auto muted) 00100: Auto mute flag for left channel 00101: Auto mute flag for right channel 00110: Clock invalid flag (clock error or clock changing or clock missing) 00111: Serial audio interface data output (SDOUT) 01000: Analog mute flag for left channel (low active) 01001: Analog mute flag for right channel (low active) 01010: PLL lock flag 01011: Charge pump clock 01100: Reserved 01101: Reserved

	01110: Under voltage flag, asserted when XSMUTE voltage is higher than 0.7 DVDD 01111: Under voltage flag, asserted when XSMUTE voltage is higher than 0.3 DVDD 010000: PLL Output/4 (Requires Clock Flex Register) OTHERS: RESERVED
--	---

**Table 88. Page 0 / Register 82**

Dec	Hex	b7	b6	b5	b4	b3	b2	b1	b0
82	52	RSV	RSV	RSV	G3SL4	G3SL3	G3SL2	G3SL1	G3SL0
Reset Value					0	0	0	0	0

<b>RSV</b>	<b>Reserved</b> Reserved. Do not access.
<b>G3SL[4:0]</b>	<b>GPIO3 Output Selection</b> These bits select the signal to output to GPIO3. To actually output the selected signal, the GPIO3 must be set to output mode at Page 0 / Register 8. Default value: 00000 0000: off (low) 0001: DSP GPIO3 output 0010: Register GPIO3 output (Page 0 / Register 86, bit 2) 00011: Auto mute flag (asserted when both L and R channels are auto muted) 00100: Auto mute flag for left channel 00101: Auto mute flag for right channel 00110: Clock invalid flag (clock error or clock changing or clock missing) 00111: Serial audio interface data output (SDOUT) 01000: Analog mute flag for left channel (low active) 01001: Analog mute flag for right channel (low active) 01010: PLL lock flag 01011: Charge pump clock 01100: Reserved 01101: Reserved 01110: Under voltage flag, asserted when XSMUTE voltage is higher than 0.7 DVDD 01111: Under voltage flag, asserted when XSMUTE voltage is higher than 0.3 DVDD 010000: PLL Output/4 (Requires Clock Flex Register) OTHERS: RESERVED

**Table 89. Page 0 / Register 83**

Dec	Hex	b7	b6	b5	b4	b3	b2	b1	b0
83	53	RSV	RSV	RSV	G4SL4	G4SL3	G4SL2	G4SL1	G4SL0
Reset Value					0	0	0	0	0

<b>RSV</b>	<b>Reserved</b> Reserved. Do not access.
<b>G4SL[4:0]</b>	<b>GPIO4 Output Selection</b> These bits select the signal to output to GPIO4. To actually output the selected signal, the GPIO4 must be set to output mode at Page 0 / Register 8. Default value: 00000 00000: off (low) 00001: DSP GPIO4 output 00010: Register GPIO4 output (Page 0 / Register 86, bit 3) 00011: Auto mute flag (asserted when both L and R channels are auto muted)

	00100: Auto mute flag for left channel 00101: Auto mute flag for right channel 00110: Clock invalid flag (clock error or clock changing or clock missing) 00111: Serial audio interface data output (SDOUT) 01000: Analog mute flag for left channel (low active) 01001: Analog mute flag for right channel (low active) 01010: PLL lock flag 01011: Charge pump clock 01100: Reserved 01101: Reserved 01110: Under voltage flag, asserted when XSMUTE voltage is higher than 0.7 DVDD 01111: Under voltage flag, asserted when XSMUTE voltage is higher than 0.3 DVDD 010000: PLL Output/4 (Requires Clock Flex Register) OTHERS: RESERVED
--	--

**Table 90. Page 0 / Register 84**

Dec	Hex	b7	b6	b5	b4	b3	b2	b1	b0
84	54	RSV	RSV	RSV	G5SL4	G5SL3	G5SL2	G5SL1	G5SL0
Reset Value					0	0	0	0	0

<b>RSV</b>	<b>Reserved</b> Reserved. Do not access.
<b>G5SL[4:0]</b>	<b>GPIO5 Output Selection</b> These bits select the signal to output to GPIO5. To actually output the selected signal, the GPIO5 must be set to output mode at Page 0 / Register 8. Default value: 00000 00000: off (low) 00001: DSP GPIO5 output 00010: Register GPIO5 output (Page 0 / Register 86, bit 4) 00011: Auto mute flag (asserted when both L and R channels are auto muted) 00100: Auto mute flag for left channel 00101: Auto mute flag for right channel 00110: Clock invalid flag (clock error or clock changing or clock missing) 00111: Serial audio interface data output (SDOUT) 01000: Analog mute flag for left channel (low active) 01001: Analog mute flag for right channel (low active) 01010: PLL lock flag 01011: Charge pump clock 01100: Reserved 01101: Reserved 01110: Under voltage flag, asserted when XSMUTE voltage is higher than 0.7 DVDD 01111: Under voltage flag, asserted when XSMUTE voltage is higher than 0.3 DVDD 010000: PLL Output/4 (Requires Clock Flex Register) OTHERS: RESERVED

**Table 91. Page 0 / Register 85**

Dec	Hex	b7	b6	b5	b4	b3	b2	b1	b0
85	55	RSV	RSV	RSV	G6SL4	G6SL3	G6SL2	G6SL1	G6SL0
Reset Value					0	0	0	0	0

<b>RSV</b>	<b>Reserved</b> Reserved. Do not access.
<b>G6SL[4:0]</b>	<b>GPIO6 Output Selection</b> These bits select the signal to output to GPIO6. To actually output the selected signal, the GPIO6 must be set to output mode at Page 0 / Register 8. Default value: 00000 00000: off (low) 00001: DSP GPIO6 output 00010: Register GPIO6 output (Page 0 / Register 86, bit 5) 00011: Auto mute flag (asserted when both L and R channels are auto muted) 00100: Auto mute flag for left channel 00101: Auto mute flag for right channel 00110: Clock invalid flag (clock error or clock changing or clock missing) 00111: Serial audio interface data output (SDOUT) 01000: Analog mute flag for left channel (low active) 01001: Analog mute flag for right channel (low active) 01010: PLL lock flag 01011: Charge pump clock 01100: Reserved 01101: Reserved 01110: Under voltage flag, asserted when XSMUTE voltage is higher than 0.7 DVDD 01111: Under voltage flag, asserted when XSMUTE voltage is higher than 0.3 DVDD 010000: PLL Output/4 (Requires Clock Flex Register) OTHERS: RESERVED

**Table 92. Page 0 / Register 86**

Dec	Hex	b7	b6	b5	b4	b3	b2	b1	b0
86	56	RSV	RSV	GOUT5	GOUT4	GOUT3	GOUT2	GOUT1	GOUT0
Reset Value				0	0	0	0	0	0

<b>RSV</b>	<b>Reserved</b> Reserved. Do not access.
<b>GOUT5</b>	<b>GPIO6 Output Control</b> This bit controls the GPIO6 output when the selection at Page 0 / Register 85 is set to 0010 (register output) Default value: 0 0: Output low 1: Output high
<b>GOUT4</b>	<b>GPIO5 Output Control</b> This bit controls the GPIO5 output when the selection at Page 0 / Register 84 is set to 0010 (register output) Default value: 0 0: Output low 1: Output high
<b>GOUT3</b>	<b>GPIO4 Output Control</b> This bit controls the GPIO4 output when the selection at Page 0 / Register 83 is set to 0010 (register output) Default value: 0 0: Output low 1: Output high
<b>GOUT2</b>	<b>GPIO3 Output Control</b> This bit controls the GPIO3 output when the selection at Page 0 / Register 82 is set to 0010 (register output) Default value: 0

	0: Output low 1: Output high
<b>GOUT1</b>	<b>GPIO2 Output Control</b> This bit controls the GPIO2 output when the selection at Page 0 / Register 81 is set to 0010 (register output) Default value: 0 0: Output low 1: Output high
<b>GOUT0</b>	<b>GPIO1 Output Control</b> This bit controls the GPIO1 output when the selection at Page 0 / Register 80 is set to 0010 (register output) Default value: 0 0: Output low 1: Output high

**Table 93. Page 0 / Register 87**

Dec	Hex	b7	b6	b5	b4	b3	b2	b1	b0
87	57	RSV	RSV	GINV5	GINV4	GINV3	GINV2	GINV1	GINV0
Reset Value				0	0	0	0	0	0

<b>RSV</b>	<b>Reserved</b> Reserved. Do not access.
<b>GINV5</b>	<b>GPIO6 Output Inversion</b> This bit controls the polarity of GPIO6 output. When set to 1, the output will be inverted for any signal being selected. Default value: 0 0: Non-inverted 1: Inverted
<b>GINV4</b>	<b>GPIO5 Output Inversion</b> This bit controls the polarity of GPIO5 output. When set to 1, the output will be inverted for any signal being selected. Default value: 0 0: Non-inverted 1: Inverted
<b>GINV3</b>	<b>GPIO4 Output Inversion</b> This bit controls the polarity of GPIO4 output. When set to 1, the output will be inverted for any signal being selected. Default value: 0 0: Non-inverted 1: Inverted
<b>GINV2</b>	<b>GPIO3 Output Inversion</b> This bit controls the polarity of GPIO3 output. When set to 1, the output will be inverted for any signal being selected. Default value: 0 0: Non-inverted 1: Inverted
<b>GINV1</b>	<b>GPIO2 Output Inversion</b> This bit controls the polarity of GPIO2 output. When set to 1, the output will be inverted for any signal being selected. Default value: 0 0: Non-inverted 1: Inverted
<b>GINV0</b>	<b>GPIO1 Output Inversion</b>

	<p>This bit controls the polarity of GPIO1 output. When set to 1, the output will be inverted for any signal being selected.</p> <p style="text-align: center;">Default value: 0 0: Non-inverted 1: Inverted</p>
--	--

**Table 94. Page 0 / Register 90**

Dec	Hex	b7	b6	b5	b4	b3	b2	b1	b0
90	5A	RSV	RSV	RSV	L1OV	R1OV	L2OV	R2OV	SFOV
Reset Value									

<b>RSV</b>	<p><b>Reserved</b> Reserved. Do not access.</p>
<b>L1OV</b>	<p><b>Left1 Overflow (Read Only)</b> This bit indicates whether the left channel of DSP first output port has overflow. This bit is sticky and is cleared when read.</p> <p style="text-align: center;">0: No overflow 1: Overflow occurred</p>
<b>R1OV</b>	<p><b>Right1 Overflow (Read Only)</b> The bit indicates whether the right channel of DSP first output port has overflow. This bit is sticky and is cleared when read.</p> <p style="text-align: center;">0: No overflow 1: Overflow occurred</p>
<b>L2OV</b>	<p><b>Left2 Overflow (Read Only)</b> This bit indicates whether the left channel of DSP second output port has overflow. This bit is sticky and is cleared when read.</p> <p style="text-align: center;">0: No overflow 1: Overflow occurred</p>
<b>R2OV</b>	<p><b>Right2 Overflow (Read Only)</b> The bit indicates whether the right channel of DSP second output port has overflow. This bit is sticky and is cleared when read.</p> <p style="text-align: center;">0: No overflow 1: Overflow occurred</p>
<b>SFOV</b>	<p><b>Shifter Overflow (Read Only)</b> This bit indicates whether overflow occurred in the DSP shifter (possible sample corruption). This bit is sticky and is cleared when read.</p> <p style="text-align: center;">0: No overflow 1: Overflow occurred</p>

**Table 95. Page 0 / Register 91**

Dec	Hex	b7	b6	b5	b4	b3	b2	b1	b0
91	5B	RSV	DTFS2	DTFS1	DTFS0	DTSR3	DTSR2	DTSR1	DTSR0
Reset Value									

<b>RSV</b>	<p><b>Reserved</b> Reserved. Do not access.</p>
<b>DTFS[2:0]</b>	<p><b>Detected FS (Read Only)</b> These bits indicate the currently detected audio sampling rate.</p> <p style="text-align: center;">000: Error (Out of valid range) 001: 8 kHz 010: 16 kHz</p>

	011: 32-48 kHz 100: 88.2-96 kHz 101: 176.4-192 kHz 110: 384 kHz
<b>DTSR[3:0]</b>	<b>Detected SCK Ratio (Read Only)</b> These bits indicate the currently detected SCK ratio. Note that even if the SCK ratio is not indicated as error, clock error might still be flagged due to incompatible combination with the sampling rate. Specifically the SCK ratio must be high enough to allow enough DSP cycles for minimal audio processing when PLL is disabled. The absolute SCK frequency must also be lower than 50 MHz. 0000: Ratio error (The SCK ratio is not allowed) 0001: SCK = 32 FS 0010: SCK = 48 FS 0011: SCK = 64 FS 0100: SCK = 128 FS 0101: SCK = 192 FS 0110: SCK = 256 FS 0111: SCK = 384 FS 1000: SCK = 512 FS 1001: SCK = 768 FS 1010: SCK = 1024 FS 1011: SCK = 1152 FS 1100: SCK = 1536 FS 1101: SCK = 2048 FS 1110: SCK = 3072 FS

**Table 96. Page 0 / Register 92**

Dec	Hex	b7	b6	b5	b4	b3	b2	b1	b0
92	5C	RSV	RSV	RSV	RSV	RSV	RSV	RSV	DTBR8
Reset Value									

**Table 97. Page 0 / Register 93**

Dec	Hex	b7	b6	b5	b4	b3	b2	b1	b0
93	5D	DTBR7	DTBR6	DTBR5	DTBR4	DTBR3	DTBR2	DTBR1	DTBR0
Reset Value									

<b>RSV</b>	<b>Reserved</b> Reserved. Do not access.
<b>DTBR[8:0]</b>	<b>Detected BCK Ratio (MSB) (Read Only)</b> These bits indicate the currently detected BCK ratio, that is, the number of BCK clocks in one audio frame. Note that for extreme case of BCK = 1 FS (which is not usable anyway), the detected ratio will be unreliable.

**Table 98. Page 0 / Register 94**

Dec	Hex	b7	b6	b5	b4	b3	b2	b1	b0
94	5E	RSV	CDST	PLL-L	LrckBck	fS-SCKr	SCKval	BCKval	fSval
Reset Value									

<b>RSV</b>	<b>Reserved</b> Reserved. Do not access.
<b>CDST</b>	<b>Clock Detector Status (Read Only)</b> This bit indicates whether the SCK clock is present or not. 0: SCK is present



	1: SCK is missing (halted)
<b>PLL-L</b>	<b>PLL locked (Read Only)</b> This bit indicates whether the PLL is locked or not. The PLL will be reported as unlocked when it is disabled. 0: PLL is locked 1: PLL is unlocked
<b>LrckBck</b>	<b>LRCK-BCK present (Read Only)</b> This bit indicates whether the both LRCK and BCK are missing (tied low) or not. 0: LRCK and/or BCK is present 1: LRCK and BCK are missing
<b>fS-SCKr</b>	<b>Sample rate SCK ratio valid (Read Only)</b> This bit indicates whether the combination of current sampling rate and SCK ratio is valid for clock auto set. 0: The combination of FS/SCK ratio is valid 1: Error (clock auto set is not possible)
<b>SCKval</b>	<b>SCK valid (Read Only)</b> This bit indicates whether the SCK is valid or not. The SCK ratio must be detectable to be valid. There is a limitation with this flag, that is, when the low period of LRCK is less than or equal to 5 BCKs, this flag will be asserted (SCK invalid reported). 0: SCK is valid 1: SCK is invalid
<b>BCKval</b>	<b>BCK valid (Read Only)</b> This bit indicates whether the BCK is valid or not. The BCK ratio must be stable and in the range of 32-256FS to be valid. 0: BCK is valid 1: BCK is invalid
<b>fSval</b>	<b>fS valid (Read Only)</b> This bit indicated whether the audio sampling rate is valid or not. The sampling rate must be detectable to be valid. There is a limitation with this flag, that is when this flag is asserted and Page 0 / Register 37 is set to ignore all asserted error flags such that the DAC recovers, this flag will be de-asserted (sampling rate invalid not reported anymore). 0: Sampling rate is valid 1: Sampling rate is invalid

**Table 99. Page 0 / Register 95**

Dec	Hex	b7	b6	b5	b4	b3	b2	b1	b0
95	5F	RSV	RSV	RSV	LTSH	RSV	CKMF	CSRF	CERF
Reset Value									

<b>RSV</b>	<b>Reserved</b> Reserved. Do not access.
<b>LTSH</b>	<b>Latched Clock Halt (Read Only)</b> This bit indicates whether SCK halt has occurred. The bit is cleared when read. 0: SCK halt has not occurred 1: SCK halt has occurred since last read
<b>CKMF</b>	<b>Clock Missing (Read Only)</b> This bit indicates whether the LRCK and BCK are missing (tied low). 0: LRCK and/or BCK is present 1: LRCK and BCK are missing
<b>CSRF</b>	<b>Clock Resync Request (Read Only)</b> This bit indicates whether the clock resynchronization is in progress. 0: Not resynchronizing 1: Clock resynchronization is in progress

<b>CERF</b>	<b>Clock Error (Read Only)</b> This bit indicates whether a clock error is being reported. 0: Clock is valid 1: Clock is invalid (Error)
-------------	---

**Table 100. Page 0 / Register 108**

Dec	Hex	b7	b6	b5	b4	b3	b2	b1	b0
108	6C	RSV	RSV	RSV	RSV	RSV	RSV	AMLM	AMRM
Reset Value									

<b>RSV</b>	<b>Reserved</b> Reserved. Do not access.
<b>AMLM</b>	<b>Left Analog Mute Monitor (Read Only)</b> This bit is a monitor for left channel analog mute status. 0: Mute 1: Unmute
<b>AMRM</b>	<b>Right Analog Mute Monitor (Read Only)</b> This bit is a monitor for right channel analog mute status. 0: Mute 1: Unmute

**Table 101. Page 0 / Register 109**

Dec	Hex	b7	b6	b5	b4	b3	b2	b1	b0
109	6D	RSV	RSV	RSV	SDTM	RSV	RSV	RSV	SHTM
Reset Value									

<b>RSV</b>	<b>Reserved</b> Reserved. Do not access.
<b>SDTM</b>	<b>Short detect monitor (Read Only)</b> This bit indicates whether line output short is occurring. 0: Normal (No short) 1: Line output is being shorted
<b>SHTM</b>	<b>Short detected monitor (Read Only)</b> This bit indicates whether line output short has occurred since last read. This bit is sticky and is cleared when read. 0: No short 1: Line output short occurred

**Table 102. Page 0 / Register 114**

Dec	Hex	b7	b6	b5	b4	b3	b2	b1	b0
114	72	RSV	RSV	RSV	RSV	RSV	RSV	MTST1	MTST0
Reset Value									

<b>RSV</b>	<b>Reserved</b> Reserved. Do not access.
<b>MTST[1:0]</b>	<b>MUTEZ status (Read Only)</b> These bits indicate the output of the XSMUTE level decoder for monitoring purpose. 11: $0.7 \text{ VDD} \leq \text{XSMUTE}$ 01: $0.3 \text{ VDD} \leq \text{XSMUTE} < 0.7 \text{ VDD}$ 00: $0.3 \text{ VDD} > \text{XSMUTE}$

**Table 103. Page 0 / Register 115**

Dec	Hex	b7	b6	b5	b4	b3	b2	b1	b0
115	73	RSV	RSV	RSV	RSV	RSV	RSV	FSMM1	FSMM0
Reset Value									

<b>RSV</b>	<b>Reserved</b> Reserved. Do not access.
<b>FSMM[1:0]</b>	<b>FS Speed Mode Monitor (Read Only)</b> These bits indicate the actual FS operation mode being used. The actual value is the auto set one when clock auto set is active and register set one when clock auto set is disabled.  00: Single speed (FS ≤ 48 kHz) 01: Double speed (48 kHz < FS ≤ 96 kHz) 10: Quad speed (96 kHz < FS ≤ 192 kHz) 11: Octal speed (192 kHz < FS ≤ 384 kHz)

**Table 104. Page 0 / Register 118**

Dec	Hex	b7	b6	b5	b4	b3	b2	b1	b0
118	76	BOTM	RSV	RSV	RSV	PSTM3	PSTM2	PSTM1	PSTM0
Reset Value									

<b>RSV</b>	<b>Reserved</b> Reserved. Do not access.
<b>BOTM</b>	<b>DSP Boot Done Flag (Read Only)</b> This bit indicates whether the DSP boot is completed.  0: DSP is booting 1: DSP boot completed
<b>PSTM[3:0]</b>	<b>Power State (Read Only)</b> These bits indicate the current power state of the DAC.  0000: Powerdown 0001: Wait for CP voltage valid 0010: Calibration 0011: Calibration 0100: Volume ramp up 0101: Run (Playing) 0110: Line output short / Low impedance 0111: Volume ramp down 1000: Standby

**Table 105. Page 0 / Register 119**

Dec	Hex	b7	b6	b5	b4	b3	b2	b1	b0
119	77	RSV	RSV	GPIN5	GPIN4	GPIN3	GPIN2	GPIN1	RSV
Reset Value									

<b>RSV</b>	<b>Reserved</b> Reserved. Do not access.
<b>GPIN[5:0]</b>	<b>GPIO Input States (Read Only)</b> This bit indicates the logic level at GPIO6 pin.  0: Low 1: High

**Table 106. Page 0 / Register 120**

Dec	Hex	b7	b6	b5	b4	b3	b2	b1	b0
120	78	RSV	RSV	RSV	AMFL	RSV	RSV	RSV	AMFR
Reset Value									

<b>RSV</b>	<b>Reserved</b> Reserved. Do not access.
<b>AMFL</b>	<b>Auto Mute Flag for Left Channel (Read Only)</b> This bit indicates the auto mute status for left channel. 0: Not auto muted 1: Auto muted
<b>AMFR</b>	<b>Auto Mute Flag for Right Channel (Read Only)</b> This bit indicates the auto mute status for right channel. 0: Not auto muted 1: Auto muted

**Table 107. Page 0 / Register 121**

Dec	Hex	b7	b6	b5	b4	b3	b2	b1	b0
121	79	RSV	RSV	RSV	RSV	RSV	RSV	RSV	DAMD
Reset Value									0

<b>RSV</b>	<b>Reserved</b> Reserved. Do not access.
<b>DAMD</b>	<b>DAC Mode</b> This bit controls the DAC architecture to vary the DAC auditory signature. Default value: 0 0: Mode1 - New hyper-advanced current-segment architecture 1: Mode2 - Classic PCM1792 advanced current-segment architecture

**Table 108. Page 0 / Register 122**

Dec	Hex	b7	b6	b5	b4	b3	b2	b1	b0
122	7A	RSV	RSV	RSV	RSV	RSV	RSV	RSV	EIFM
Reset Value									0

<b>RSV</b>	<b>Reserved</b> Reserved. Do not access.
<b>EIFM</b>	<b>External Interpolation Filter Mode</b> This bit enables or disables the PCM1792 External Interpolation Filter Mode. This mode is used with a PCM1792 in external digital filter mode. Default value: 0 0: Normal mode 1: External Interpolation Filter Mode

**Table 109. Page 0 / Register 123**

Dec	Hex	b7	b6	b5	b4	b3	b2	b1	b0
123	7B	RSV	G1MC2	G1MC1	G1MC0	RSV	G2MC2	G2MC1	G2MC0
Reset Value			0	0	0		0	0	0

<b>RSV</b>	<b>Reserved</b> Reserved. Do not access.
<b>G1MC[2:0]</b>	<b>GPIO1 output for External Interpolation Filter Mode</b> These bits select a signal to be output to GPIO1 in External Interpolation Filter mode. Default value: 000 000: Logic low 001: MS 010: BCK (256FS) 011: WDCK (8FS) 100: DATAL 101: DATAR 110: Raw DIN (from DIN pin) 111: Raw LRCK (from LRCK pin)
<b>G2MC[2:0]</b>	<b>GPIO2 output for External Interpolation Filter Mode</b> These bits select a signal to be output to GPIO2 in External Interpolation Filter mode. Default value: 000 000: Logic low 001: MS 010: BCK (256FS) 011: WDCK (8FS) 100: DATAL 101: DATAR 110: Raw DIN (from DIN pin) 111: Raw LRCK (from LRCK pin)

**Table 110. Page 0 / Register 124**

Dec	Hex	b7	b6	b5	b4	b3	b2	b1	b0
124	7C	RSV	G3MC2	G3MC1	G3MC0	RSV	G4MC2	G4MC1	G4MC0
Reset Value			0	0	0		0	0	0

<b>RSV</b>	<b>Reserved</b> Reserved. Do not access.
<b>G3MC[2:0]</b>	<b>GPIO3 output for External Interpolation Filter Mode</b> These bits select a signal to be output to GPIO3 in External Interpolation Filter Mode. Default value: 000 000: Logic low 001: MS 010: BCK (256FS) 011: WDCK (8FS) 100: DATAL 101: DATAR 110: Raw DIN (from DIN pin) 111: Raw LRCK (from LRCK pin)
<b>G4MC[2:0]</b>	<b>GPIO4 output for External Interpolation Filter Mode</b> These bits select a signal to be output to GPIO4 in External Interpolation Filter Mode. Default value: 000 000: Logic low 001: MS 010: BCK (256FS)

	011: WDCK (8FS) 100: DATAL 101: DATAR 110: Raw DIN (from DIN pin) 111: Raw LRCK (from LRCK pin)
--	---

**Table 111. Page 0 / Register 125**

Dec	Hex	b7	b6	b5	b4	b3	b2	b1	b0
125	7D	RSV	G5MC2	G5MC1	G5MC0	RSV	G6MC2	G6MC1	G6MC0
Reset Value			0	0	0		0	0	0

<b>RSV</b>	<b>Reserved</b> Reserved. Do not access.
<b>G5MC[2:0]</b>	<b>GPIO5 output for External Interpolation Filter Mode</b> These bits select a signal to be output to GPIO5 in External Interpolation Filter mode. Default value: 000 000: Logic low 001: MS 010: BCK (256FS) 011: WDCK (8FS) 100: DATAL 101: DATAR 110: Raw DIN (from DIN pin) 111: Raw LRCK (from LRCK pin)
<b>G6MC[2:0]</b>	<b>GPIO6 output for External Interpolation Filter Mode</b> These bits select a signal to be output to GPIO6 in External Interpolation Filter mode. Default value: 000 000: Logic low 001: MS 010: BCK (256FS) 011: WDCK (8FS) 100: DATAL 101: DATAR 110: Raw DIN (from DIN pin) 111: Raw LRCK (from LRCK pin)

### 13.1.1.3 Page 1 Registers

**Table 112. Page 1 / Register 1**

Dec	Hex	b7	b6	b5	b4	b3	b2	b1	b0
1	01	RSV	RSV	RSV	RSV	RSV	RSV	RSV	OSEL
Reset Value									0

<b>RSV</b>	<b>Reserved</b> Reserved. Do not access.
<b>OSEL</b>	<b>Output Amplitude Type</b> This bit selects the output amplitude type. The clock autoselect feature will not work with PLL enabled in VCOM mode. In this case this feature has to be disabled via Page 0 / Register 37 and the clock dividers must be set manually. Default value: 0

	0: VREF mode (Constant output amplitude against AVDD variation) 1: VCOM mode (Output amplitude is proportional to AVDD variation)
--	--

**Table 113. Page 1 / Register 2**

Dec	Hex	b7	b6	b5	b4	b3	b2	b1	b0
2	02	RSV	RSV	RSV	LAGN	RSV	RSV	RSV	RAGN
Reset Value					0				0

<b>RSV</b>	<b>Reserved</b> Reserved. Do not access.
<b>LAGN</b>	<b>Analog Gain Control for Left Channel</b> This bit controls the left channel analog gain.  Default value: 0 0: 0 dB 1: -6 dB
<b>RAGN</b>	<b>Analog Gain Control for Right Channel</b> This bit controls the right channel analog gain.  Default value: 0 0: 0 dB 1: -6 dB

**Table 114. Page 1 / Register 5**

Dec	Hex	b7	b6	b5	b4	b3	b2	b1	b0
5	05	RSV	RSV	RSV	RSV	RSV	RSV	UEPD	UIPD
Reset Value								0	0

<b>RSV</b>	<b>Reserved</b> Reserved. Do not access.
<b>UEPD</b>	<b>External UVP Control</b> This bit enables or disables detection of power supply drop via XSMUTE pin (External Under Voltage Protection).  Default value: 0 0: Enabled 1: Disabled
<b>UIPD</b>	<b>Internal UVP Control</b> This bit enables or disables internal detection of AVDD voltage drop (Internal Under Voltage Protection).  Default value: 0 0: Enabled 1: Disabled

**Table 115. Page 1 / Register 6**

Dec	Hex	b7	b6	b5	b4	b3	b2	b1	b0
6	06	RSV	RSV	RSV	RSV	RSV	RSV	RSV	AMCT
Reset Value									0

<b>RSV</b>	<b>Reserved</b> Reserved. Do not access.
<b>AMCT</b>	<b>Analog Mute Control</b> This bit enables or disables analog mute following digital mute.  Default value: 0

	0: Enabled 1: Disabled
--	---------------------------

**Table 116. Page 1 / Register 7**

Dec	Hex	b7	b6	b5	b4	b3	b2	b1	b0
7	07	RSV	RSV	RSV	AGBL	RSV	RSV	RSV	AGBR
Reset Value					0				0

<b>RSV</b>	<b>Reserved</b> Reserved. Do not access.
<b>AGBL</b>	<b>Analog +10% Gain for Left Channel</b> This bit enables or disables amplitude boost mode for left channel. Default value: 0 0: Normal amplitude 1: +10% (+0.8 dB) boosted amplitude
<b>AGBR</b>	<b>Analog +10% Gain for Right Channel</b> This bit enables or disables amplitude boost mode for right channel. Default value: 0 0: Normal amplitude 1: +10% (+0.8 dB) boosted amplitude

**Table 117. Page 1 / Register 8**

Dec	Hex	b7	b6	b5	b4	b3	b2	b1	b0
8	08	RSV	RSV	RSV	RSV	RSV	RSV	RSV	RCMF
Reset Value									0

<b>RSV</b>	<b>Reserved</b> Reserved. Do not access.
<b>RCMF</b>	<b>VCOM Reference Ramp Up</b> This bit controls the VCOM voltage ramp up speed. Default value: 0 0: Normal ramp up, ~600ms with external capacitance = 1uF 1: Fast ramp up, ~3ms with external capacitance = 1uF

**Table 118. Page 1 / Register 9**

Dec	Hex	b7	b6	b5	b4	b3	b2	b1	b0
9	09	RSV	RSV	RSV	RSV	RSV	RSV	RSV	VCPD
Reset Value									1

<b>RSV</b>	<b>Reserved</b> Reserved. Do not access.
<b>VCPD</b>	<b>Power down control for VCOM</b> This bit controls VCOM powerdown switch. Default value: 1 0: VCOM is powered on 1: VCOM is powered down



**13.1.1.4 Page 44 Registers**
**Table 119. Page 44 / Register 1**

Dec	Hex	b7	b6	b5	b4	b3	b2	b1	b0
1	01	RSV	RSV	RSV	RSV	ACRM	AMDC	ACRS	ACSW
Reset Value							0		0

<b>RSV</b>	<b>Reserved</b> Reserved. Do not access.
<b>ACRM</b>	<b>Active CRAM Monitor (Read Only)</b> This bit indicates which CRAM is being accessed by the DSP when adaptive mode is disabled. When adaptive mode is enabled, this bit has no meaning. 0: CRAM A is being used by the DSP 1: CRAM B is being used by the DSP
<b>AMDC</b>	<b>Adaptive Mode Control</b> This bit controls the DSP adaptive mode. When in adaptive mode, only CRAM A is accessible via serial interface when the DSP is disabled (DAC in standby state), while when the DSP is enabled (DAC is run state) the CRAM A can only be accessed by the DSP and the CRAM B can only be accessed by the serial interface, or vice versa depending on the value of CRAMSTAT. When not in adaptive mode, both CRAM A and B can be accessed by the serial interface when the DSP is disabled, but when the DSP is enabled, no CRAM can be accessed by serial interface. The DSP can access either CRAM, which can be monitored at SWPMON. Default value: 0 0: Adaptive mode disabled 1: Adaptive mode enabled
<b>ACRS</b>	<b>Active CRAM Selection (Read Only)</b> This bit indicates which CRAM currently serves as the active one. The other CRAM serves as an update buffer, and can accessed by serial interface (SPI/I2C) 0: CRAM A is active and being used by the DSP 1: CRAM B is active and being used by the DSP
<b>ACSW</b>	<b>Switch Active CRAM</b> This bit is used to request switching roles of the two buffers, that is, switching the active buffer role between CRAM A and CRAM B. This bit is cleared automatically when the switching process completed. Default value: 0 0: No switching requested or switching completed 1: Switching is being requested

**13.1.1.5 Page 253 Registers**
**Table 120. Page 253 / Register 63**

Dec	Hex	b7	b6	b5	b4	b3	b2	b1	b0
63	3F	PLL FLEX1 7	PLL FLEX1 6	PLL FLEX1 5	PLL FLEX1 4	PLL FLEX1 3	PLL FLEX1 2	PLL FLEX1 1	PLL FLEX1 0
Reset Value		0	0	0	0	0	0	0	0

<b>PLL FLEX1[7:0]</b>	<b>Clock Flex Register #1</b> Clock Flex Register #1. Write 0x11 to this register to allow advanced clock tree functions. See Clocking Overview section. Default value: 00000000
-----------------------	--

**Table 121. Page 253 / Register 64**

Dec	Hex	b7	b6	b5	b4	b3	b2	b1	b0
64	40	PLLFLEX2 7	PLLFLEX2 6	PLLFLEX2 5	PLLFLEX2 4	PLLFLEX2 3	PLLFLEX2 2	PLLFLEX2 1	PLLFLEX2 0
Reset Value		0	0	0	0	0	0	0	0

<b>PLLFLEX2[7:0]</b>	<b>Clock Flex Register #2</b> Clock Flex Register #2. Write 0xFF to this register to allow advanced clock tree functions. See Clocking Overview section. Default value: 00000000
----------------------	--

### 13.1.2 PLL Tables for Software Controlled Devices

**Table 122. Recommended Clock Divider Settings for PLL as Master Clock (VREF Mode)**

f <sub>s</sub> (kHz)	RSCK	SCK (MHz)	PLL VCO (MHz)	P	PLL REF (MHz)	M = K*R	K = J.D	R	PLL f <sub>s</sub>	DSP f <sub>s</sub>	NMAC	DSP CLK (MHz)	MOD f <sub>s</sub>	MOD F (kHz)	NDAC	DOSR	% ERROR	NCP	CP F (kHz)
8	128	1.024	98.304	1	1.024	96	48	2	12288	1024	12	8.192	768	6144	16	48	0	4	1536
8	192	1.536	98.304	1	1.536	64	32	2	12288	1024	12	8.192	768	6144	16	48	0	4	1536
8	256	2.048	98.304	1	2.048	48	48	1	12288	1024	12	8.192	768	6144	16	48	0	4	1536
8	384	3.072	98.304	3	1.024	96	48	2	12288	1024	12	8.192	768	6144	16	48	0	4	1536
8	512	4.096	98.304	3	1.365	72	36	2	12288	1024	12	8.192	768	6144	16	48	0	4	1536
8	768	6.144	98.304	3	2.048	48	48	1	12288	1024	12	8.192	768	6144	16	48	0	4	1536
8	1024	8.192	98.304	3	2.731	36	36	1	12288	1024	12	8.192	768	6144	16	48	0	4	1536
8	1152	9.216	98.304	9	1.024	96	48	2	12288	1024	12	8.192	768	6144	16	48	0	4	1536
8	1536	12.288	98.304	9	1.365	72	36	2	12288	1024	12	8.192	768	6144	16	48	0	4	1536
8	2048	16.384	98.304	9	1.82	54	54	1	12288	1024	12	8.192	768	6144	16	48	0	4	1536
8	3072	24.576	98.304	9	2.731	36	36	1	12288	1024	12	8.192	768	6144	16	48	0	4	1536
11.025	128	1.4112	90.3168	1	1.411	64	32	2	8192	1024	8	11.2896	512	5644.8	16	32	0	4	1411.2
11.025	192	2.1168	90.3168	3	0.706	128	32	4	8192	1024	8	11.2896	512	5644.8	16	32	0	4	1411.2
11.025	256	2.8224	90.3168	1	2.822	32	32	1	8192	1024	8	11.2896	512	5644.8	16	32	0	4	1411.2
11.025	384	4.2336	90.3168	3	1.411	64	32	2	8192	1024	8	11.2896	512	5644.8	16	32	0	4	1411.2
11.025	512	5.6448	90.3168	3	1.882	48	48	1	8192	1024	8	11.2896	512	5644.8	16	32	0	4	1411.2
11.025	768	8.4672	90.3168	3	2.822	32	32	1	8192	1024	8	11.2896	512	5644.8	16	32	0	4	1411.2
11.025	1024	11.2896	90.3168	3	3.763	24	24	1	8192	1024	8	11.2896	512	5644.8	16	32	0	4	1411.2
11.025	1152	12.7008	90.3168	9	1.411	64	32	2	8192	1024	8	11.2896	512	5644.8	16	32	0	4	1411.2
11.025	1536	16.9344	90.3168	9	1.882	48	48	1	8192	1024	8	11.2896	512	5644.8	16	32	0	4	1411.2
11.025	2048	22.5792	90.3168	9	2.509	36	36	1	8192	1024	8	11.2896	512	5644.8	16	32	0	4	1411.2
11.025	3072	33.8688	90.3168	9	3.763	24	24	1	8192	1024	8	11.2896	512	5644.8	16	32	0	4	1411.2
16	64	1.024	98.304	1	1.024	96	48	2	6144	1024	6	16.384	384	6144	16	24	0	4	1536
16	128	2.048	98.304	1	2.048	48	48	1	6144	1024	6	16.384	384	6144	16	24	0	4	1536
16	192	3.072	98.304	1	3.072	32	32	1	6144	1024	6	16.384	384	6144	16	24	0	4	1536
16	256	4.096	98.304	1	4.096	24	24	1	6144	1024	6	16.384	384	6144	16	24	0	4	1536
16	384	6.144	98.304	3	2.048	48	48	1	6144	1024	6	16.384	384	6144	16	24	0	4	1536
16	512	8.192	98.304	3	2.731	36	36	1	6144	1024	6	16.384	384	6144	16	24	0	4	1536
16	768	12.288	98.304	3	4.096	24	24	1	6144	1024	6	16.384	384	6144	16	24	0	4	1536
16	1024	16.384	98.304	3	5.461	18	18	1	6144	1024	6	16.384	384	6144	16	24	0	4	1536
16	1152	18.432	98.304	3	6.144	16	16	1	6144	1024	6	16.384	384	6144	16	24	0	4	1536
16	1536	24.576	98.304	9	2.731	36	36	1	6144	1024	6	16.384	384	6144	16	24	0	4	1536
16	2048	32.768	98.304	9	3.641	27	27	1	6144	1024	6	16.384	384	6144	16	24	0	4	1536
16	3072	49.152	98.304	9	5.461	18	18	1	6144	1024	6	16.384	384	6144	16	24	0	4	1536
22.05	64	1.4112	90.3168	1	1.411	64	32	2	4096	1024	4	22.5792	256	5644.8	16	16	0	4	1411.2
22.05	128	2.8224	90.3168	1	2.822	32	32	1	4096	1024	4	22.5792	256	5644.8	16	16	0	4	1411.2

**Table 122. Recommended Clock Divider Settings for PLL as Master Clock (VREF Mode) (continued)**

f <sub>s</sub> (kHz)	RSCK	SCK (MHz)	PLL VCO (MHz)	P	PLL REF (MHz)	M = K*R	K = J.D	R	PLL f <sub>s</sub>	DSP f <sub>s</sub>	NMAC	DSP CLK (MHz)	MOD f <sub>s</sub>	MOD F (kHz)	NDAC	DOSR	% ERROR	NCP	CP F (kHz)
22.05	192	4.2336	90.3168	3	1.411	64	32	2	4096	1024	4	22.5792	256	5644.8	16	16	0	4	1411.2
22.05	256	5.6448	90.3168	1	5.645	16	16	1	4096	1024	4	22.5792	256	5644.8	16	16	0	4	1411.2
22.05	384	8.4672	90.3168	3	2.822	32	32	1	4096	1024	4	22.5792	256	5644.8	16	16	0	4	1411.2
22.05	512	11.2896	90.3168	3	3.763	24	24	1	4096	1024	4	22.5792	256	5644.8	16	16	0	4	1411.2
22.05	768	16.9344	90.3168	3	5.645	16	16	1	4096	1024	4	22.5792	256	5644.8	16	16	0	4	1411.2
22.05	1024	22.5792	90.3168	3	7.526	12	12	1	4096	1024	4	22.5792	256	5644.8	16	16	0	4	1411.2
22.05	1152	25.4016	90.3168	9	2.822	32	32	1	4096	1024	4	22.5792	256	5644.8	16	16	0	4	1411.2
22.05	1536	33.8688	90.3168	9	3.763	24	24	1	4096	1024	4	22.5792	256	5644.8	16	16	0	4	1411.2
22.05	2048	45.1584	90.3168	9	5.018	18	18	1	4096	1024	4	22.5792	256	5644.8	16	16	0	4	1411.2
32	32	1.024	98.304	1	1.024	96	48	2	3072	1024	3	32.768	192	6144	16	12	0	4	1536
32	48	1.536	98.304	1	1.536	64	16	4	3072	1024	3	32.768	192	6144	16	12	0	4	1536
32	64	2.048	98.304	1	2.048	48	24	2	3072	1024	3	32.768	192	6144	16	12	0	4	1536
32	128	4.096	98.304	1	4.096	24	24	1	3072	1024	3	32.768	192	6144	16	12	0	4	1536
32	192	6.144	98.304	3	2.048	48	48	1	3072	1024	3	32.768	192	6144	16	12	0	4	1536
32	256	8.192	98.304	2	4.096	24	24	1	3072	1024	3	32.768	192	6144	16	12	0	4	1536
32	384	12.288	98.304	3	4.096	24	24	1	3072	1024	3	32.768	192	6144	16	12	0	4	1536
32	512	16.384	98.304	3	5.461	18	18	1	3072	1024	3	32.768	192	6144	16	12	0	4	1536
32	768	24.576	98.304	3	8.192	12	12	1	3072	1024	3	32.768	192	6144	16	12	0	4	1536
32	1024	32.768	98.304	3	10.923	9	9	1	3072	1024	3	32.768	192	6144	16	12	0	4	1536
32	1152	36.864	98.304	9	4.096	24	24	1	3072	1024	3	32.768	192	6144	16	12	0	4	1536
32	1536	49.152	98.304	6	8.192	12	12	1	3072	1024	3	32.768	192	6144	16	12	0	4	1536
44.1	32	1.4112	90.3168	1	1.411	64	32	2	2048	1024	2	45.1584	128	5644.8	16	8	0	4	1411.2
44.1	64	2.8224	90.3168	1	2.822	32	16	2	2048	1024	2	45.1584	128	5644.8	16	8	0	4	1411.2
44.1	128	5.6448	90.3168	1	5.645	16	16	1	2048	1024	2	45.1584	128	5644.8	16	8	0	4	1411.2
44.1	192	8.4672	90.3168	3	2.822	32	32	1	2048	1024	2	45.1584	128	5644.8	16	8	0	4	1411.2
44.1	256	11.2896	90.3168	2	5.645	16	16	1	2048	1024	2	45.1584	128	5644.8	16	8	0	4	1411.2
44.1	384	16.9344	90.3168	3	5.645	16	16	1	2048	1024	2	45.1584	128	5644.8	16	8	0	4	1411.2
44.1	512	22.5792	90.3168	3	7.526	12	12	1	2048	1024	2	45.1584	128	5644.8	16	8	0	4	1411.2
44.1	768	33.8688	90.3168	3	11.29	8	8	1	2048	1024	2	45.1584	128	5644.8	16	8	0	4	1411.2
44.1	1024	45.1584	90.3168	3	15.053	6	6	1	2048	1024	2	45.1584	128	5644.8	16	8	0	4	1411.2
48	32	1.536	98.304	1	1.536	64	32	2	2048	1024	2	49.152	128	6144	16	8	0	4	1536
48	64	3.072	98.304	1	3.072	32	16	2	2048	1024	2	49.152	128	6144	16	8	0	4	1536
48	128	6.144	98.304	1	6.144	16	16	1	2048	1024	2	49.152	128	6144	16	8	0	4	1536
48	192	9.216	98.304	3	3.072	32	32	1	2048	1024	2	49.152	128	6144	16	8	0	4	1536
48	256	12.288	98.304	2	6.144	16	16	1	2048	1024	2	49.152	128	6144	16	8	0	4	1536
48	384	18.432	98.304	3	6.144	16	16	1	2048	1024	2	49.152	128	6144	16	8	0	4	1536
48	512	24.576	98.304	3	8.192	12	12	1	2048	1024	2	49.152	128	6144	16	8	0	4	1536
48	768	36.864	98.304	3	12.288	8	8	1	2048	1024	2	49.152	128	6144	16	8	0	4	1536

**Table 122. Recommended Clock Divider Settings for PLL as Master Clock (VREF Mode) (continued)**

f <sub>s</sub> (kHz)	RSCK	SCK (MHz)	PLL VCO (MHz)	P	PLL REF (MHz)	M = K*R	K = J.D	R	PLL f <sub>s</sub>	DSP f <sub>s</sub>	NMAC	DSP CLK (MHz)	MOD f <sub>s</sub>	MOD F (kHz)	NDAC	DOSR	% ERROR	NCP	CP F (kHz)
48	1024	49.152	98.304	3	16.384	6	6	1	2048	1024	2	49.152	128	6144	16	8	0	4	1536
96	32	3.072	98.304	1	3.072	32	16	2	1024	512	2	49.152	64	6144	16	4	0	4	1536
96	48	4.608	98.304	3	1.536	64	32	2	1024	512	2	49.152	64	6144	16	4	0	4	1536
96	64	6.144	98.304	1	6.144	16	8	2	1024	512	2	49.152	64	6144	16	4	0	4	1536
96	128	12.288	98.304	2	6.144	16	16	1	1024	512	2	49.152	64	6144	16	4	0	4	1536
96	192	18.432	98.304	3	6.144	16	16	1	1024	512	2	49.152	64	6144	16	4	0	4	1536
96	256	24.576	98.304	4	6.144	16	16	1	1024	512	2	49.152	64	6144	16	4	0	4	1536
96	384	36.864	98.304	6	6.144	16	16	1	1024	512	2	49.152	64	6144	16	4	0	4	1536
96	512	49.152	98.304	8	6.144	16	16	1	1024	512	2	49.152	64	6144	16	4	0	4	1536
192	32	6.144	98.304	1	6.144	16	8	2	512	256	2	49.152	32	6144	16	2	0	4	1536
192	48	9.216	98.304	3	3.072	32	16	2	512	256	2	49.152	32	6144	16	2	0	4	1536
192	64	12.288	98.304	1	12.288	8	4	2	512	256	2	49.152	32	6144	16	2	0	4	1536
192	128	24.576	98.304	2	12.288	8	8	1	512	256	2	49.152	32	6144	16	2	0	4	1536
192	192	36.864	98.304	3	12.288	8	8	1	512	256	2	49.152	32	6144	16	2	0	4	1536
192	256	49.152	98.304	4	12.288	8	8	1	512	256	2	49.152	32	6144	16	2	0	4	1536
384	32	12.288	98.304	2	6.144	16	8	2	256	128	2	49.152	16	6144	16	1	0	4	1536
384	48	18.432	98.304	3	6.144	16	8	2	256	128	2	49.152	16	6144	16	1	0	4	1536
384	64	24.576	98.304	2	12.288	8	4	2	256	128	2	49.152	16	6144	16	1	0	4	1536
384	128	49.152	98.304	4	12.288	8	8	1	256	128	2	49.152	16	6144	16	1	0	4	1536

**Table 123. Recommended Clock Divider Settings for PLL as Master Clock (VCOM Mode)**

$f_s$ (kHz)	RSCK	SCK (MHz)	PLL VCO (MHz)	P	PLL REF (MHz)	M = K*R	K = J.D	R	PLL $f_s$	DSP $f_s$	NMAC	DSP CLK (MHz)	MOD $f_s$	MOD F (kHz)	NDAC	DOSR	% ERROR	NCP	CP F (kHz)
8	128	1.024	73.728	1	1.024	72	36	2	9216	768	12	6.144	768	6144	12	48	0	4	1536
8	192	1.536	73.728	1	1.536	48	24	2	9216	768	12	6.144	768	6144	12	48	0	4	1536
8	256	2.048	73.728	1	2.048	36	36	1	9216	768	12	6.144	768	6144	12	48	0	4	1536
8	384	3.072	73.728	1	3.072	24	12	2	9216	768	12	6.144	768	6144	12	48	0	4	1536
8	512	4.096	73.728	2	2.048	36	36	1	9216	768	12	6.144	768	6144	12	48	0	4	1536
8	768	6.144	73.728	3	2.048	36	36	1	9216	768	12	6.144	768	6144	12	48	0	4	1536
8	1024	8.192	73.728	4	2.048	36	36	1	9216	768	12	6.144	768	6144	12	48	0	4	1536
8	1152	9.216	73.728	6	1.536	48	48	1	9216	768	12	6.144	768	6144	12	48	0	4	1536
8	1536	12.288	73.728	6	2.048	36	36	1	9216	768	12	6.144	768	6144	12	48	0	4	1536
8	2048	16.384	73.728	8	2.048	36	36	1	9216	768	12	6.144	768	6144	12	48	0	4	1536
8	3072	24.576	73.728	12	2.048	36	36	1	9216	768	12	6.144	768	6144	12	48	0	4	1536
11.025	128	1.4112	84.672	1	1.411	60	30	2	7680	960	8	10.584	512	5644.8	15	32	0	4	1411.2
11.025	192	2.1168	84.672	1	2.117	40	10	4	7680	960	8	10.584	512	5644.8	15	32	0	4	1411.2
11.025	256	2.8224	84.672	1	2.822	30	30	1	7680	960	8	10.584	512	5644.8	15	32	0	4	1411.2
11.025	384	4.2336	84.672	2	2.117	40	20	2	7680	960	8	10.584	512	5644.8	15	32	0	4	1411.2
11.025	512	5.6448	84.672	2	2.822	30	30	1	7680	960	8	10.584	512	5644.8	15	32	0	4	1411.2
11.025	768	8.4672	84.672	3	2.822	30	30	1	7680	960	8	10.584	512	5644.8	15	32	0	4	1411.2
11.025	1024	11.2896	84.672	4	2.822	30	30	1	7680	960	8	10.584	512	5644.8	15	32	0	4	1411.2
11.025	1152	12.7008	84.672	6	2.117	40	20	2	7680	960	8	10.584	512	5644.8	15	32	0	4	1411.2
11.025	1536	16.9344	84.672	8	2.117	40	40	1	7680	960	8	10.584	512	5644.8	15	32	0	4	1411.2
11.025	2048	22.5792	84.672	8	2.822	30	30	1	7680	960	8	10.584	512	5644.8	15	32	0	4	1411.2
11.025	3072	33.8688	84.672	8	4.234	20	20	1	7680	960	8	10.584	512	5644.8	15	32	0	4	1411.2
16	64	1.024	73.728	1	1.024	72	36	2	4608	768	6	12.288	384	6144	12	24	0	4	1536
16	128	2.048	73.728	1	2.048	36	36	1	4608	768	6	12.288	384	6144	12	24	0	4	1536
16	192	3.072	73.728	1	3.072	24	24	1	4608	768	6	12.288	384	6144	12	24	0	4	1536
16	256	4.096	73.728	2	2.048	36	36	1	4608	768	6	12.288	384	6144	12	24	0	4	1536
16	384	6.144	73.728	3	2.048	36	36	1	4608	768	6	12.288	384	6144	12	24	0	4	1536
16	512	8.192	73.728	4	2.048	36	36	1	4608	768	6	12.288	384	6144	12	24	0	4	1536
16	768	12.288	73.728	6	2.048	36	36	1	4608	768	6	12.288	384	6144	12	24	0	4	1536
16	1024	16.384	73.728	8	2.048	36	36	1	4608	768	6	12.288	384	6144	12	24	0	4	1536
16	1152	18.432	73.728	9	2.048	36	36	1	4608	768	6	12.288	384	6144	12	24	0	4	1536
16	1536	24.576	73.728	8	3.072	24	24	1	4608	768	6	12.288	384	6144	12	24	0	4	1536
16	2048	32.768	73.728	8	4.096	18	18	1	4608	768	6	12.288	384	6144	12	24	0	4	1536
16	3072	49.152	73.728	8	6.144	12	12	1	4608	768	6	12.288	384	6144	12	24	0	4	1536
22.05	64	1.4112	84.672	1	1.411	60	30	2	3840	960	4	21.168	256	5644.8	15	16	0	4	1411.2
22.05	128	2.8224	84.672	1	2.822	30	30	1	3840	960	4	21.168	256	5644.8	15	16	0	4	1411.2
22.05	192	4.2336	84.672	3	1.411	60	30	2	3840	960	4	21.168	256	5644.8	15	16	0	4	1411.2
22.05	256	5.6448	84.672	2	2.822	30	30	1	3840	960	4	21.168	256	5644.8	15	16	0	4	1411.2

**Table 123. Recommended Clock Divider Settings for PLL as Master Clock (VCOM Mode) (continued)**

f <sub>s</sub> (kHz)	RSCK	SCK (MHz)	PLL VCO (MHz)	P	PLL REF (MHz)	M = K*R	K = J.D	R	PLL f <sub>s</sub>	DSP f <sub>s</sub>	NMAC	DSP CLK (MHz)	MOD f <sub>s</sub>	MOD F (kHz)	NDAC	DOSR	% ERROR	NCP	CP F (kHz)
22.05	384	8.4672	84.672	3	2.822	30	30	1	3840	960	4	21.168	256	5644.8	15	16	0	4	1411.2
22.05	512	11.2896	84.672	2	5.645	15	15	1	3840	960	4	21.168	256	5644.8	15	16	0	4	1411.2
22.05	768	16.9344	84.672	3	5.645	15	15	1	3840	960	4	21.168	256	5644.8	15	16	0	4	1411.2
22.05	1024	22.5792	84.672	4	5.645	15	15	1	3840	960	4	21.168	256	5644.8	15	16	0	4	1411.2
22.05	1152	25.4016	84.672	9	2.822	30	30	1	3840	960	4	21.168	256	5644.8	15	16	0	4	1411.2
22.05	1536	33.8688	84.672	8	4.234	20	20	1	3840	960	4	21.168	256	5644.8	15	16	0	4	1411.2
22.05	2048	45.1584	84.672	8	5.645	15	15	1	3840	960	4	21.168	256	5644.8	15	16	0	4	1411.2
32	32	1.024	73.728	1	1.024	72	36	2	2304	768	3	24.576	192	6144	12	12	0	4	1536
32	48	1.536	73.728	1	1.536	48	12	4	2304	768	3	24.576	192	6144	12	12	0	4	1536
32	64	2.048	73.728	1	2.048	36	18	2	2304	768	3	24.576	192	6144	12	12	0	4	1536
32	128	4.096	73.728	2	2.048	36	36	1	2304	768	3	24.576	192	6144	12	12	0	4	1536
32	192	6.144	73.728	3	2.048	36	36	1	2304	768	3	24.576	192	6144	12	12	0	4	1536
32	256	8.192	73.728	4	2.048	36	36	1	2304	768	3	24.576	192	6144	12	12	0	4	1536
32	384	12.288	73.728	6	2.048	36	36	1	2304	768	3	24.576	192	6144	12	12	0	4	1536
32	512	16.384	73.728	8	2.048	36	36	1	2304	768	3	24.576	192	6144	12	12	0	4	1536
32	768	24.576	73.728	6	4.096	18	18	1	2304	768	3	24.576	192	6144	12	12	0	4	1536
32	1024	32.768	73.728	8	4.096	18	18	1	2304	768	3	24.576	192	6144	12	12	0	4	1536
32	1152	36.864	73.728	9	4.096	18	18	1	2304	768	3	24.576	192	6144	12	12	0	4	1536
32	1536	49.152	73.728	12	4.096	18	18	1	2304	768	3	24.576	192	6144	12	12	0	4	1536
44.1	32	1.4112	84.672	1	1.411	60	30	2	1920	960	2	42.336	128	5644.8	15	8	0	4	1411.2
44.1	48	2.1168	84.672	1	2.117	40	10	4	1920	960	2	42.336	128	5644.8	15	8	0	4	1411.2
44.1	64	2.8224	84.672	1	2.822	30	15	2	1920	960	2	42.336	128	5644.8	15	8	0	4	1411.2
44.1	128	5.6448	84.672	1	5.645	15	15	1	1920	960	2	42.336	128	5644.8	15	8	0	4	1411.2
44.1	192	8.4672	84.672	2	4.234	20	20	1	1920	960	2	42.336	128	5644.8	15	8	0	4	1411.2
44.1	256	11.2896	84.672	2	5.645	15	15	1	1920	960	2	42.336	128	5644.8	15	8	0	4	1411.2
44.1	384	16.9344	84.672	3	5.645	15	15	1	1920	960	2	42.336	128	5644.8	15	8	0	4	1411.2
44.1	512	22.5792	84.672	4	5.645	15	15	1	1920	960	2	42.336	128	5644.8	15	8	0	4	1411.2
44.1	768	33.8688	84.672	6	5.645	15	15	1	1920	960	2	42.336	128	5644.8	15	8	0	4	1411.2
44.1	1024	45.1584	84.672	8	5.645	15	15	1	1920	960	2	42.336	128	5644.8	15	8	0	4	1411.2
48	32	1.536	73.728	1	1.536	48	24	2	1536	768	2	36.864	128	6144	12	8	0	4	1536
48	48	2.304	73.728	1	2.304	32	8	4	1536	768	2	36.864	128	6144	12	8	0	4	1536
48	64	3.072	73.728	1	3.072	24	12	2	1536	768	2	36.864	128	6144	12	8	0	4	1536
48	128	6.144	73.728	2	3.072	24	24	1	1536	768	2	36.864	128	6144	12	8	0	4	1536
48	192	9.216	73.728	3	3.072	24	24	1	1536	768	2	36.864	128	6144	12	8	0	4	1536
48	256	12.288	73.728	4	3.072	24	24	1	1536	768	2	36.864	128	6144	12	8	0	4	1536
48	384	18.432	73.728	6	3.072	24	24	1	1536	768	2	36.864	128	6144	12	8	0	4	1536
48	512	24.576	73.728	4	6.144	12	12	1	1536	768	2	36.864	128	6144	12	8	0	4	1536
48	768	36.864	73.728	6	6.144	12	12	1	1536	768	2	36.864	128	6144	12	8	0	4	1536

**Table 123. Recommended Clock Divider Settings for PLL as Master Clock (VCOM Mode) (continued)**

$f_s$ (kHz)	RSCK	SCK (MHz)	PLL VCO (MHz)	P	PLL REF (MHz)	M = K*R	K = J.D	R	PLL $f_s$	DSP $f_s$	NMAC	DSP CLK (MHz)	MOD $f_s$	MOD F (kHz)	NDAC	DOSR	% ERROR	NCP	CP F (kHz)
48	1024	49.152	73.728	8	6.144	12	12	1	1536	768	2	36.864	128	6144	12	8	0	4	1536
96	32	3.072	73.728	2	1.536	48	24	2	768	384	2	36.864	64	6144	12	4	0	4	1536
96	48	4.608	73.728	3	1.536	48	24	2	768	384	2	36.864	64	6144	12	4	0	4	1536
96	64	6.144	73.728	2	3.072	24	12	2	768	384	2	36.864	64	6144	12	4	0	4	1536
96	128	12.288	73.728	4	3.072	24	24	1	768	384	2	36.864	64	6144	12	4	0	4	1536
96	192	18.432	73.728	6	3.072	24	24	1	768	384	2	36.864	64	6144	12	4	0	4	1536
96	256	24.576	73.728	8	3.072	24	24	1	768	384	2	36.864	64	6144	12	4	0	4	1536
96	384	36.864	73.728	6	6.144	12	12	1	768	384	2	36.864	64	6144	12	4	0	4	1536
96	512	49.152	73.728	8	6.144	12	12	1	768	384	2	36.864	64	6144	12	4	0	4	1536
192	32	6.144	73.728	2	3.072	24	12	2	384	192	2	36.864	32	6144	12	2	0	4	1536
192	48	9.216	73.728	3	3.072	24	12	2	384	192	2	36.864	32	6144	12	2	0	4	1536
192	64	12.288	73.728	4	3.072	24	12	2	384	192	2	36.864	32	6144	12	2	0	4	1536
192	128	24.576	73.728	8	3.072	24	24	1	384	192	2	36.864	32	6144	12	2	0	4	1536
192	192	36.864	73.728	6	6.144	12	12	1	384	192	2	36.864	32	6144	12	2	0	4	1536
192	256	49.152	73.728	8	6.144	12	12	1	384	192	2	36.864	32	6144	12	2	0	4	1536
384	32	12.288	73.728	2	6.144	12	6	2	192	96	2	36.864	16	6144	12	1	0	4	1536
384	48	18.432	73.728	3	6.144	12	6	2	192	96	2	36.864	16	6144	12	1	0	4	1536
384	64	24.576	73.728	4	6.144	12	6	2	192	96	2	36.864	16	6144	12	1	0	4	1536
384	128	49.152	73.728	8	6.144	12	12	1	192	96	2	36.864	16	6144	12	1	0	4	1536



**Table 124. Recommended Clock Divider Settings for SCK as Master Clock**

$f_s$ (kHz)	RSCK	SCK (MHz)	DSP $f_s$	NMAC	DSP CLK (MHz)	MOD $f_s$	MOD f (kHz)	NDAC	DOSR	NCP	CP f (kHz)
8	256	2.048	256	1	2.048	256	2048	1	16	2	1024
8	384	3.072	384	1	3.072	384	3072	1	24	2	1536
8	512	4.096	512	1	4.096	512	4096	1	32	2	2048
8	768	6.144	768	1	6.144	768	6144	1	48	4	1536
8	1024	8.192	1024	1	8.192	512	4096	2	32	2	2048
8	1152	9.216	1152	1	9.216	576	4608	2	36	4	1152
8	1536	12.288	1536	1	12.288	768	6144	2	48	4	1536
8	2048	16.384	2048	1	16.384	512	4096	4	32	2	2048
8	3072	24.576	3072	1	24.576	768	6144	4	48	4	1536
11.025	256	2.8224	256	1	2.822	256	2822.4	1	16	2	1411.2
11.025	384	4.2336	384	1	4.234	384	4233.6	1	24	4	1058.4
11.025	1152	12.7008	1152	1	12.701	384	4233.6	3	24	4	1058.4
11.025	1536	16.9344	1536	1	16.934	512	5644.8	3	32	4	1411.2
11.025	2048	22.5792	2048	1	22.579	512	5644.8	4	32	4	1411.2
11.025	3072	33.8688	3072	1	33.869	512	5644.8	6	32	4	1411.2
16	256	4.096	256	1	4.096	256	4096	1	16	2	2048
16	384	6.144	384	1	6.144	384	6144	1	24	4	1536
16	512	8.192	512	1	8.192	256	4096	2	16	2	2048
16	768	12.288	768	1	12.288	384	6144	2	24	4	1536
16	1152	18.432	1152	1	18.432	288	4608	4	18	4	1152
16	1536	24.576	1536	1	24.576	384	6144	4	24	4	1536
16	2048	32.768	2048	1	32.768	256	4096	8	16	2	2048
16	3072	49.152	3072	1	49.152	384	6144	8	24	4	1536
22.05	256	5.6448	256	1	5.645	256	5644.8	1	16	4	1411.2
22.05	384	8.4672	384	1	8.467	192	4233.6	2	12	4	1058.4
22.05	512	11.2896	512	1	11.29	256	5644.8	2	16	4	1411.2
22.05	768	16.9344	768	1	16.934	256	5644.8	3	16	4	1411.2
22.05	1024	22.5792	1024	1	22.579	256	5644.8	4	16	4	1411.2
22.05	1152	25.4016	1152	1	25.402	192	4233.6	6	12	4	1058.4
22.05	1536	33.8688	1536	1	33.869	256	5644.8	6	16	4	1411.2
22.05	2048	45.1584	2048	1	45.158	256	5644.8	8	16	4	1411.2
32	256	8.192	256	1	8.192	128	4096	2	8	2	2048
32	384	12.288	384	1	12.288	128	4096	3	8	2	2048
32	512	16.384	512	1	16.384	128	4096	4	8	2	2048
32	768	24.576	768	1	24.576	128	4096	6	8	2	2048
32	1024	32.768	1024	1	32.768	128	4096	8	8	2	2048
32	1152	36.864	1152	1	36.864	128	4096	9	8	4	1024
32	1536	49.152	1536	1	49.152	128	4096	12	8	4	1024
44.1	256	11.2896	256	1	11.29	128	5644.8	2	8	4	1411.2
44.1	384	16.9344	384	1	16.934	128	5644.8	3	8	4	1411.2
44.1	512	22.5792	512	1	22.579	128	5644.8	4	8	4	1411.2
44.1	768	33.8688	768	1	33.869	128	5644.8	6	8	4	1411.2
44.1	1024	45.1584	1024	1	45.158	128	5644.8	8	8	4	1411.2
48	256	12.288	256	1	12.288	128	6144	2	8	4	1536
48	384	18.432	384	1	18.432	128	6144	3	8	4	1536
48	512	24.576	512	1	24.576	128	6144	4	8	4	1536
48	768	36.864	768	1	36.864	128	6144	6	8	4	1536
48	1024	49.152	1024	1	49.152	128	6144	8	8	4	1536
96	192	18.432	192	1	18.432	48	4608	4	3	6	768
96	256	24.576	256	1	24.576	64	6144	4	4	4	1536
96	384	36.864	384	1	36.864	64	6144	6	4	4	1536
96	512	49.152	512	1	49.152	64	6144	8	4	4	1536

**Table 124. Recommended Clock Divider Settings for SCK as Master Clock (continued)**

$f_s$ (kHz)	R_SCK	SCK (MHz)	DSP $f_s$	NMAC	DSP CLK (MHz)	MOD $f_s$	MOD f (kHz)	NDAC	DOSR	NCP	CP f (kHz)
192	128	24.576	128	1	24.576	32	6144	4	2	4	1536
192	192	36.864	192	1	36.864	32	6144	6	2	4	1536
192	256	49.152	256	1	49.152	32	6144	8	2	4	1536
384	64	24.576	64	1	24.576	16	6144	4	1	4	1536
384	128	49.152	128	1	49.152	16	6144	8	1	4	1536

## 14 器件和文档支持

### 14.1 社区资源

[E2E™ 音频转换器论坛 TI](#)

[E2E 社区](#)

### 14.2 商标

PurePath is a trademark of Texas Instruments.

System Two Cascade, Audio Precision are trademarks of Audio Precision.

DirectPath is a trademark of Texas, Instruments, Inc..

All other trademarks are the property of their respective owners.

### 14.3 静电放电警告



ESD 可能会损坏该集成电路。德州仪器 (TI) 建议通过适当的预防措施处理所有集成电路。如果不遵守正确的处理措施和安装程序，可能会损坏集成电路。

ESD 的损坏小至导致微小的性能降级，大至整个器件故障。精密的集成电路可能更容易受到损坏，这是因为非常细微的参数更改都可能会导致器件与其发布的规格不相符。

## 15 机械、封装和可订购信息

以下页中包括机械、封装和可订购信息。这些信息是针对指定器件可提供的最新数据。这些数据会在无通知且不对本文档进行修订的情况下发生改变。欲获得该数据表的浏览器版本，请查阅左侧的导航栏。

**PACKAGING INFORMATION**

Orderable part number	Status (1)	Material type (2)	Package   Pins	Package qty   Carrier	RoHS (3)	Lead finish/ Ball material (4)	MSL rating/ Peak reflow (5)	Op temp (°C)	Part marking (6)
<a href="#">PCM5252RHBR</a>	Active	Production	VQFN (RHB)   32	3000   LARGE T&R	Yes	NIPDAU	Level-1-260C-UNLIM	-25 to 85	PCM5252
PCM5252RHBR.A	Active	Production	VQFN (RHB)   32	3000   LARGE T&R	Yes	NIPDAU	Level-1-260C-UNLIM	-25 to 85	PCM5252
<a href="#">PCM5252RHBT</a>	Active	Production	VQFN (RHB)   32	250   SMALL T&R	Yes	NIPDAU	Level-1-260C-UNLIM	-25 to 85	PCM5252
PCM5252RHBT.A	Active	Production	VQFN (RHB)   32	250   SMALL T&R	Yes	NIPDAU	Level-1-260C-UNLIM	-25 to 85	PCM5252

(1) **Status:** For more details on status, see our [product life cycle](#).

(2) **Material type:** When designated, preproduction parts are prototypes/experimental devices, and are not yet approved or released for full production. Testing and final process, including without limitation quality assurance, reliability performance testing, and/or process qualification, may not yet be complete, and this item is subject to further changes or possible discontinuation. If available for ordering, purchases will be subject to an additional waiver at checkout, and are intended for early internal evaluation purposes only. These items are sold without warranties of any kind.

(3) **RoHS values:** Yes, No, RoHS Exempt. See the [TI RoHS Statement](#) for additional information and value definition.

(4) **Lead finish/Ball material:** Parts may have multiple material finish options. Finish options are separated by a vertical ruled line. Lead finish/Ball material values may wrap to two lines if the finish value exceeds the maximum column width.

(5) **MSL rating/Peak reflow:** The moisture sensitivity level ratings and peak solder (reflow) temperatures. In the event that a part has multiple moisture sensitivity ratings, only the lowest level per JEDEC standards is shown. Refer to the shipping label for the actual reflow temperature that will be used to mount the part to the printed circuit board.

(6) **Part marking:** There may be an additional marking, which relates to the logo, the lot trace code information, or the environmental category of the part.

Multiple part markings will be inside parentheses. Only one part marking contained in parentheses and separated by a "~" will appear on a part. If a line is indented then it is a continuation of the previous line and the two combined represent the entire part marking for that device.

**Important Information and Disclaimer:** The information provided on this page represents TI's knowledge and belief as of the date that it is provided. TI bases its knowledge and belief on information provided by third parties, and makes no representation or warranty as to the accuracy of such information. Efforts are underway to better integrate information from third parties. TI has taken and continues to take reasonable steps to provide representative and accurate information but may not have conducted destructive testing or chemical analysis on incoming materials and chemicals. TI and TI suppliers consider certain information to be proprietary, and thus CAS numbers and other limited information may not be available for release.

In no event shall TI's liability arising out of such information exceed the total purchase price of the TI part(s) at issue in this document sold by TI to Customer on an annual basis.

## GENERIC PACKAGE VIEW

**RHB 32**

**VQFN - 1 mm max height**

5 x 5, 0.5 mm pitch

PLASTIC QUAD FLATPACK - NO LEAD



Images above are just a representation of the package family, actual package may vary.  
Refer to the product data sheet for package details.

4224745/A



4223442/B 08/2019

NOTES:

1. All linear dimensions are in millimeters. Any dimensions in parenthesis are for reference only. Dimensioning and tolerancing per ASME Y14.5M.
2. This drawing is subject to change without notice.
3. The package thermal pad must be soldered to the printed circuit board for thermal and mechanical performance.

# EXAMPLE BOARD LAYOUT

RHB0032E

VQFN - 1 mm max height

PLASTIC QUAD FLATPACK - NO LEAD



LAND PATTERN EXAMPLE  
SCALE:18X



SOLDER MASK DETAILS

4223442/B 08/2019

NOTES: (continued)

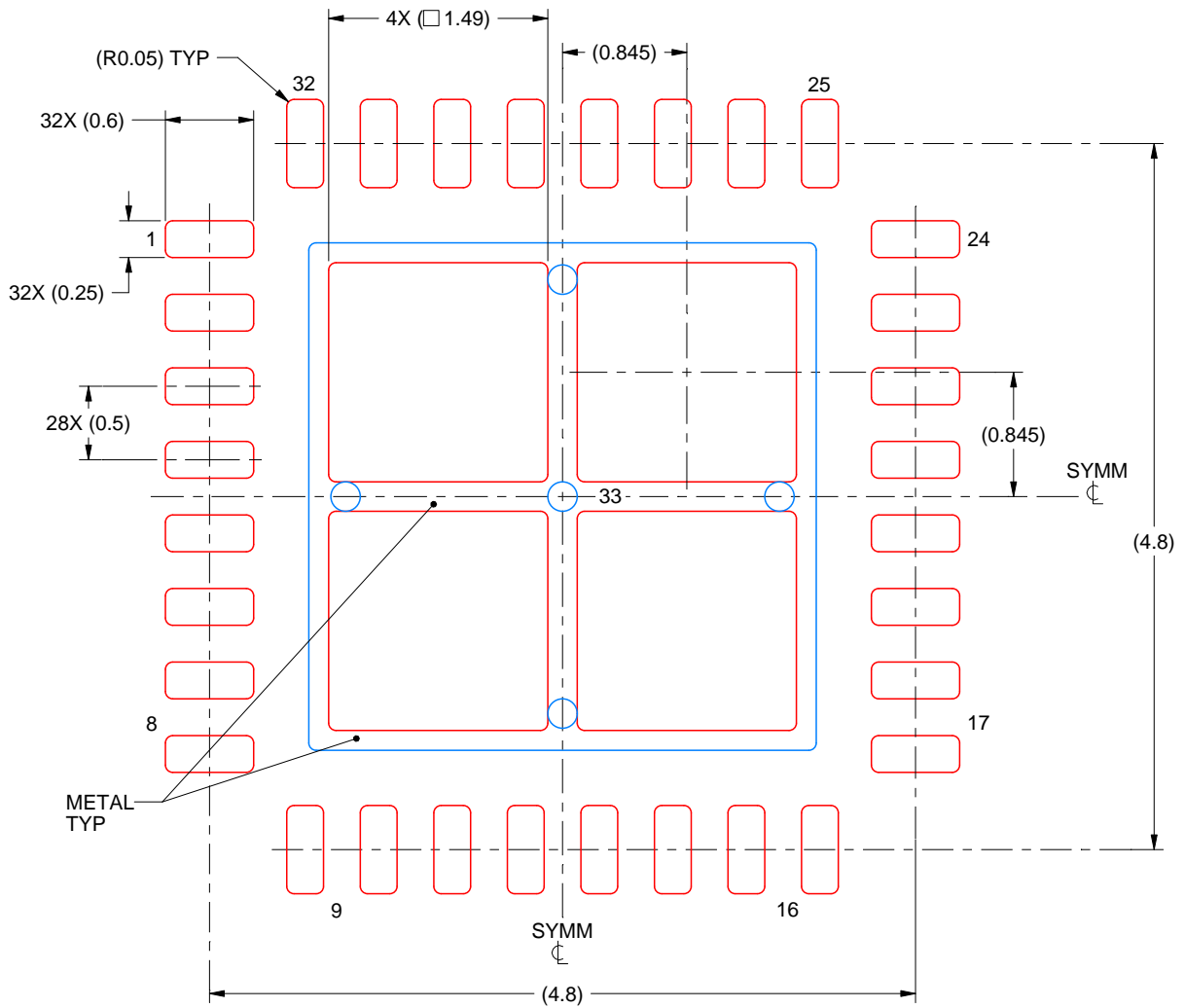
4. This package is designed to be soldered to a thermal pad on the board. For more information, see Texas Instruments literature number SLUA271 ([www.ti.com/lit/sluea271](http://www.ti.com/lit/sluea271)).
5. Vias are optional depending on application, refer to device data sheet. If any vias are implemented, refer to their locations shown on this view. It is recommended that vias under paste be filled, plugged or tented.

# EXAMPLE STENCIL DESIGN

RHB0032E

VQFN - 1 mm max height

PLASTIC QUAD FLATPACK - NO LEAD



**SOLDER PASTE EXAMPLE**  
 BASED ON 0.125 mm THICK STENCIL

EXPOSED PAD 33:  
 75% PRINTED SOLDER COVERAGE BY AREA UNDER PACKAGE  
 SCALE:20X

4223442/B 08/2019

NOTES: (continued)

6. Laser cutting apertures with trapezoidal walls and rounded corners may offer better paste release. IPC-7525 may have alternate design recommendations.



## 重要通知和免责声明

TI“按原样”提供技术和可靠性数据（包括数据表）、设计资源（包括参考设计）、应用或其他设计建议、网络工具、安全信息和其他资源，不保证没有瑕疵且不做任何明示或暗示的担保，包括但不限于对适销性、与某特定用途的适用性或不侵犯任何第三方知识产权的暗示担保。

这些资源可供使用 TI 产品进行设计的熟练开发人员使用。您将自行承担以下全部责任：(1) 针对您的应用选择合适的 TI 产品，(2) 设计、验证并测试您的应用，(3) 确保您的应用满足相应标准以及任何其他安全、安保法规或其他要求。

这些资源如有变更，恕不另行通知。TI 授权您仅可将这些资源用于研发本资源所述的 TI 产品的相关应用。严禁以其他方式对这些资源进行复制或展示。您无权使用任何其他 TI 知识产权或任何第三方知识产权。对于因您对这些资源的使用而对 TI 及其代表造成的任何索赔、损害、成本、损失和债务，您将全额赔偿，TI 对此概不负责。

TI 提供的产品受 [TI 销售条款](#)、[TI 通用质量指南](#) 或 [ti.com](#) 上其他适用条款或 TI 产品随附的其他适用条款的约束。TI 提供这些资源并不会扩展或以其他方式更改 TI 针对 TI 产品发布的适用的担保或担保免责声明。除非德州仪器 (TI) 明确将某产品指定为定制产品或客户特定产品，否则其产品均为按确定价格收入目录的标准通用器件。

TI 反对并拒绝您可能提出的任何其他或不同的条款。

版权所有 © 2025，德州仪器 (TI) 公司

最后更新日期：2025 年 10 月