

PCA9554A 具有中断输出和配置寄存器的远程 8 位 I²C 和 SMBus I/O 扩展器

1 特性

- I²C 至并行端口扩展器
- 开漏电路低电平有效中断输出
- 2.3 V 至 5.5V 的工作电源电压范围
- 耐受 5V 电压的 I/O
- 400kHz 快速 I²C 总线
- 3 个硬件地址引脚可在 I²C/SMBus 上支持最多 8 个器件
- 输入/输出配置寄存器
- 极性反转寄存器
- 内部加电复位
- 所用通道在加电时被配置为输入
- 加电时无毛刺脉冲
- 针对直接驱动 LED 的具有高电流驱动最大能力的锁存输出
- 锁断性能超过 100mA，符合 JESD 78 II 类规范的要求)
- ESD 保护性能超过 JESD 22 规范要求
 - 2000V 人体放电模型 (A114-A)
 - 200V 机器放电模型 (A115-A)
 - 1000V 带电器件模型 (C101)

2 说明

这个用于两线双向总线 (I²C) 的 8 位扩展器设计用于 2.3V 至 5.5V V_{CC} 运行。通过 I²C 接口 [串行时钟 (SCL), 串行数据 (SDA)], 它为大多数微控制器系列产品提供通用远程 I/O 扩展。

PCA9554A 包含一个 8 位配置 (输入或输出选择)、输入、输出和极性反转 (高电平有效或低电平有效) 寄存器。加电时, I/O 被配置为到 V_{CC} 的弱上拉输入。但是, 系统主控制器可以通过写入 I/O 配置位将 I/O 启用为输入或输出。每一个输入或者输出的数据被保存在相应的输入或者输出寄存器内。输入端口寄存器的极性可借助极性反转寄存器进行转换。所有寄存器都可由系统主控制器读取。

发生超时或其他不当操作时, 系统主控制器可通过使用上电复位功能, 将寄存器置于其默认状况并初始化 I²C/SMBus 状态机, 从而复位 PCA9554A。

器件信息

器件型号	封装 ⁽¹⁾	封装尺寸 (标称值)
PCA9554A	DB (SSOP) (16)	6.20mm × 5.30mm
	DBQ (VQFN) (16)	4.90mm × 3.90mm
	DGV (TSSOP) (16)	3.60mm × 4.40mm
	DW (SOIC)	10.3mm × 7.50mm
	PW (TSSOP)	5.00mm × 4.40mm
	RGT (VQFN)	3.00mm × 3.00mm
	RGV (VQFN)	4.00mm × 4.00mm

(1) 如需了解所有可用封装, 请参阅数据表末尾的可订购产品附录。

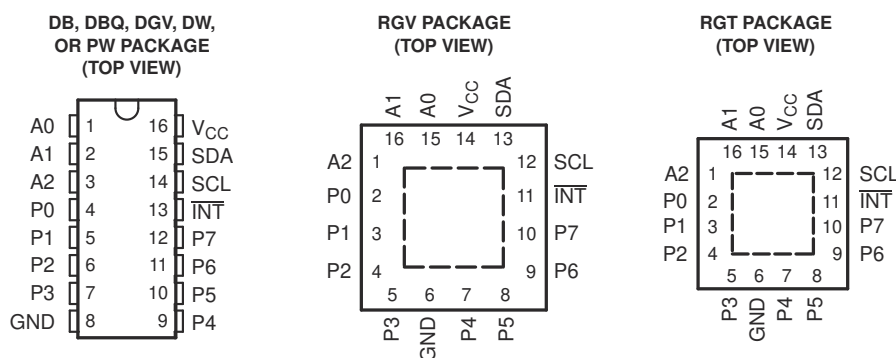

Table of Contents

1 特性	1	8 Detailed Description	13
2 说明	1	8.1 Functional Block Diagram.....	13
3 Revision History	2	8.2 Device Functional Modes.....	14
4 Description (Continued)	3	8.3 Programming.....	15
5 Pin Configuration And Functions	4	9 Application Information Disclaimer	21
6 Specifications	5	9.1 Application Information.....	21
6.1 Absolute Maximum Ratings.....	5	10 Power Supply Recommendations	23
6.2 ESD Ratings.....	5	10.1 Power-On Reset Requirements.....	23
6.3 Recommended Operating Conditions.....	5	11 Device and Documentation Support	25
6.4 Thermal Information.....	5	11.1 支持资源.....	25
6.5 Electrical Characteristics.....	6	11.2 Trademarks.....	25
6.6 I ² C Interface Timing Requirements.....	7	11.3 静电放电警告.....	25
6.7 Switching Characteristics.....	7	11.4 术语表.....	25
6.8 Typical Characteristics.....	8	12 Mechanical, Packaging, and Orderable Information	25
7 Parameter Measurement Information	10		

3 Revision History

Changes from Revision E (May 2014) to Revision F (March 2021)	Page
• 更改了器件信息表.....	1
• Moved the Storage temperature range from the Handling Ratings table to the <i>Absolute Maximum Ratings</i> table.....	5
• Moved the Package thermal impedance to the <i>Thermal Information</i> table.....	5
• Changed the V _{IH} High-level input voltage (SDL, SDA) Max value From: 5.5 V To: V _{CC} in the <i>Recommended Operating Conditions</i>	5
• Changed the V _{IL} Low-level input voltage (A2 – A0, P7 – P0) Max value From: 0.8 V To: 0.3 x V _{CC} in the <i>Recommended Operating Conditions</i>	5
• Added the <i>Thermal Information</i> table.....	5
• Changed the V _{PORR} row in the <i>Electrical Characteristics</i>	6
• Added the V _{PORF} row in the <i>Electrical Characteristics</i>	6
• Changed the I _{CC} Standby mode values in the <i>Electrical Characteristics</i>	6
• Changed the C _i SCL Max value From: 5 pF To: 8 pF in the <i>Electrical Characteristics</i>	6
• Changed the C _{io} SDA Max value From: 6.5 pF To: 9.5 pF in the <i>Electrical Characteristics</i>	6
• Changed the t _{pv} Output data valid MAX values From: 200 ns To 350 ns in the <i>Switching Characteristics</i>	7
• Changed the <i>Typical Characteristics</i> graphs.....	8
• Changed the <i>Power Supply Recommendations</i>	23

Changes from Revision D (August 2008) to Revision E (May 2014)	Page
• Added Interrupt Errata section.	15
• Added the <i>Power-On Reset Errata</i> section	23

4 Description (Continued)

The PCA9554A open-drain interrupt ($\overline{\text{INT}}$) output is activated when any input state differs from its corresponding Input Port register state and is used to indicate to the system master that an input state has changed.

$\overline{\text{INT}}$ can be connected to the interrupt input of a microcontroller. By sending an interrupt signal on this line, the remote I/O can inform the microcontroller if there is incoming data on its ports without having to communicate via the I²C bus. Thus, the PCA9554A can remain a simple slave device.

The device's outputs (latched) have high-current drive capability for directly driving LEDs and low current consumption.

Three hardware pins (A0, A1, and A2) are used to program and vary the fixed I²C address and allow up to eight devices to share the same I²C bus or SMBus.

The PCA9554A is pin-to-pin and I²C address compatible with the PCF8574A. However, software changes are required, due to the enhancements in the PCA9554A over the PCF8574A.

The PCA9554A and PCA9554 are identical except for their fixed I²C address. This allows for up to 16 of these devices (8 of each) on the same I²C/SMBus.

5 Pin Configuration And Functions



表 5-1. Pin Functions

NAME	PIN		DESCRIPTION
	QSOP (DBQ), SOIC (DW), SSOP (DB), TSSOP (PW), AND TVSOP (DGV)	QFN (RGT AND RGV)	
A0	1	15	Address input. Connect directly to V _{CC} or ground.
A1	2	16	Address input. Connect directly to V _{CC} or ground.
A2	3	1	Address input. Connect directly to V _{CC} or ground.
P0	4	2	P-port input/output. Push-pull design structure.
P1	5	3	P-port input/output. Push-pull design structure.
P2	6	4	P-port input/output. Push-pull design structure.
P3	7	5	P-port input/output. Push-pull design structure.
GND	8	6	Ground
P4	9	7	P-port input/output. Push-pull design structure.
P5	10	8	P-port input/output. Push-pull design structure.
P6	11	9	P-port input/output. Push-pull design structure.
P7	12	10	P-port input/output. Push-pull design structure.
INT	13	11	Interrupt output. Connect to V _{CC} through a pullup resistor.
SCL	14	12	Serial clock bus. Connect to V _{CC} through a pullup resistor.
SDA	15	13	Serial data bus. Connect to V _{CC} through a pullup resistor.
V _{CC}	16	14	Supply voltage

6 Specifications

6.1 Absolute Maximum Ratings

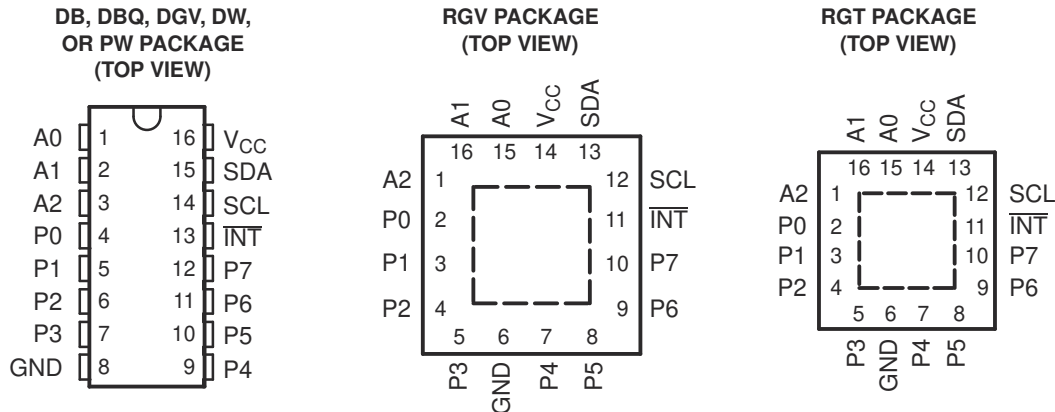
over operating free-air temperature range (unless otherwise noted) ⁽¹⁾

		MIN	MAX	UNIT
V _{CC}	Supply voltage range	- 0.5	6	V
V _I	Input voltage range ⁽²⁾	- 0.5	6	V
V _O	Output voltage range ⁽²⁾	- 0.5	6	V
I _{IK}	Input clamp current	V _I < 0	- 20	mA
I _{OK}	Output clamp current	V _O < 0	- 20	mA
I _{IOK}	Input/output clamp current	V _O < 0 or V _O > V _{CC}	±20	mA
I _{OL}	Continuous output low current	V _O = 0 to V _{CC}	50	mA
I _{OH}	Continuous output high current	V _O = 0 to V _{CC}	- 50	mA
I _{CC}	Continuous current through GND		- 250	mA
	Continuous current through V _{CC}		160	
T _{stg}	Storage temperature range	- 65	150	°C

- (1) Stresses beyond those listed under "absolute maximum ratings" may cause permanent damage to the device. These are stress ratings only, and functional operation of the device at these or any other conditions beyond those indicated under "recommended operating conditions" is not implied. Exposure to absolute-maximum-rated conditions for extended periods may affect device reliability.
- (2) The input negative-voltage and output voltage ratings may be exceeded if the input and output current ratings are observed.

6.2 ESD Ratings

			MIN	MAX	UNIT
V _(ESD)	Electrostatic discharge	Human body model (HBM), per ANSI/ESDA/JEDEC JS-001, all pins ⁽¹⁾	0	2000	V
		Charged device model (CDM), per JEDEC specification JESD22-C101, all pins ⁽²⁾	0	1000	

- (1) JEDEC document JEP155 states that 500-V HBM allows safe manufacturing with a standard ESD control process.
- (2) JEDEC document JEP157 states that 250-V CDM allows safe manufacturing with a standard ESD control process.

6.3 Recommended Operating Conditions

		MIN	MAX	UNIT
V _{CC}	Supply voltage	2.3	5.5	V
V _{IH}	High-level input voltage	SCL, SDA	0.7 × V _{CC}	V _{CC}
		A2 - A0, P7 - P0	2	5.5
V _{IL}	Low-level input voltage	SCL, SDA	- 0.5	0.3 × V _{CC}
		A2 - A0, P7 - P0	- 0.5	0.3 × V _{CC}
I _{OH}	High-level output current	P7 - P0	- 10	mA
I _{OL}	Low-level output current	P7 - P0	25	mA
T _A	Operating free-air temperature	- 40	85	°C

6.4 Thermal Information

THERMAL METRIC ⁽¹⁾		PCA9554A							UNIT
		DB (SSOP)	DBQ (SSOP)	DGV (TVSOP)	DW (SOIC)	PW (TSSOP)	RGT (TSSOP)	RGV (TSSOP)	
		16 PINS	16 PINS	16 PINS	16 PINS	16 PINS	16 PINS	16 PINS	
R _{θJA}	Junction-to-ambient thermal resistance	113.2	121.7	120	84.7	122	63.2	51	°C/W

- (1) For more information about traditional and new thermal metrics, see the [Semiconductor and IC package thermal metrics](#) application report.

6.5 Electrical Characteristics

over operating free-air temperature range (unless otherwise noted)

PARAMETER		TEST CONDITIONS	V _{CC}	MIN	TYP ⁽¹⁾	MAX	UNIT
V _{IK}	Input diode clamp voltage	I _I = -18 mA	2.3 V to 5.5 V	-1.2			V
V _{PORR}	Power-onreset voltage, V _{CC} rising	V _I = V _{CC} or GND, I _O = 0			1.2	1.5	V
V _{PORF}	Power-onreset voltage, V _{CC} falling	V _I = V _{CC} or GND, I _O = 0		0.75	1		V
V _{OH}	P-port high-level output voltage ⁽²⁾	I _{OH} = -8 mA	2.3 V	1.8			V
			3 V	2.6			
			4.5 V	3.1			
			4.75 V	4.1			
		I _{OH} = -10 mA	2.3 V	1.7			
			3 V	2.5			
			4.5 V	3			
			4.75 V	4			
I _{OL}	SDA	V _{OL} = 0.4 V	2.3 V to 5.5 V	3	8		mA
	P port ⁽³⁾	V _{OL} = 0.5 V	2.3 V	8	10		
			3 V	8	14		
			4.5 V	8	17		
			4.75 V	8	35		
	P port ⁽³⁾	V _{OL} = 0.7 V	2.3 V	10	13		
			3 V	10	19		
			4.5 V	10	24		
			4.75 V	10	45		
	INT	V _{OL} = 0.4 V	2.3 V to 5.5 V	3	10		
I _I	SCL, SDA	V _I = V _{CC} or GND	2.3 V to 5.5 V			±1	μA
	A2 - A0					±1	
I _{IH}	P port	V _I = V _{CC}	2.3 V to 5.5 V			1	μA
I _{IL}	P port	V _I = GND	2.3 V to 5.5 V			-100	μA
I _{CC}	Operating mode	V _I = V _{CC} , I _O = 0, I/O = inputs, f _{scl} = 400 kHz, No load	5.5 V		104	175	μA
			3.6 V		50	90	
			2.7 V		20	65	
		V _I = V _{CC} , I _O = 0, I/O = inputs, f _{scl} = 100 kHz, No load	5.5 V		60	150	
			3.6 V		15	40	
			2.7 V		8	20	
	Standby mode	V _I = GND, I _O = 0, I/O = inputs, f _{scl} = 0 kHz, No load	5.5 V		450	700	
			3.6 V		300	600	
		V _I = V _{CC} , I _O = 0, I/O = inputs, f _{scl} = 0 kHz, No load	2.7 V		230	500	
			5.5 V		1.9	3.5	
Standby mode	V _I = V _{CC} , I _O = 0, I/O = inputs, f _{scl} = 0 kHz, No load	3.6 V		1.1	1.8		
		2.7 V		1	1.6		
Δ I _{CC}	Additional current in standby mode	One input at V _{CC} - 0.6 V, Other inputs at V _{CC} or GND	2.3 V to 5.5 V			1.5	mA
		Every LED I/O at V _I = 4.3 V; f _{scl} = 0 kHz	5.5 V			1	
C _I	SCL	V _I = V _{CC} or GND	2.3 V to 5.5 V		4	8	pF
C _{IO}	SDA	V _{IO} = V _{CC} or GND	2.3 V to 5.5 V		5.5	9.5	pF
	P port				8	9.5	

(1) All typical values are at nominal supply voltage (2.5-V, 3.3-V, or 5-V V_{CC}) and T_A = 25°C.

(2) The total current sourced by all I/Os must be limited to 85 mA.

(3) Each I/O must be externally limited to a maximum of 25 mA, and the P port (P0 to P7) must be limited to a maximum current of 200 mA.

6.6 I²C Interface Timing Requirements

over operating free-air temperature range (unless otherwise noted) (see [图 7-1](#))

		STANDARD MODE I ² C BUS		FAST MODE I ² C BUS		UNIT		
		MIN	MAX	MIN	MAX			
f_{scl}	I ² C clock frequency	0	100	0	400	kHz		
t_{sch}	I ² C clock high time	4		0.6		μs		
t_{scl}	I ² C clock low time	4.7		1.3		μs		
t_{sp}	I ² C spike time		50		50	ns		
t_{sds}	I ² C serial-data setup time	250		100		ns		
t_{sdh}	I ² C serial-data hold time	0		0		ns		
t_{icr}	I ² C input rise time		1000	$20 + 0.1C_b$ ⁽¹⁾	300	ns		
t_{icf}	I ² C input fall time		300	$20 + 0.1C_b$ ⁽¹⁾	300	ns		
t_{ocf}	I ² C output fall time		300	$20 + 0.1C_b$ ⁽¹⁾	300	ns		
	10-pF to 400-pF bus							
t_{buf}	I ² C bus free time between Stop and Start	4.7		1.3		μs		
t_{sts}	I ² C Start or repeated Start condition setup	4.7		0.6		μs		
t_{sth}	I ² C Start or repeated Start condition hold	4		0.6		μs		
t_{sps}	I ² C Stop condition setup	4		0.6		μs		
$t_{vd(data)}$	Valid data time		SCL low to SDA output valid	300	50	ns		
$t_{vd(ack)}$	Valid data time of ACK condition		ACK signal from SCL low to SDA (out) low	0.3	3.45	0.1	0.9	μs
C_b	I ² C bus capacitive load		400		400	ns		

(1) C_b = Total capacitive load of one bus in pF

6.7 Switching Characteristics

over operating free-air temperature range (unless otherwise noted) (see [图 7-2](#) and [图 7-3](#))

PARAMETER	FROM (INPUT)	TO (OUTPUT)	STANDARD MODE I ² C BUS		FAST MODE I ² C BUS		UNIT
			MIN	MAX	MIN	MAX	
t_{iv}	Interrupt valid time	P port		4		4	μs
t_{ir}	Interrupt reset delay time	SCL		4		4	μs
t_{pv}	Output data valid	SCL		350		350	ns
t_{ps}	Input data setup time	P port	100		100		ns
t_{ph}	Input data hold time	P port	1		1		μs

6.8 Typical Characteristics

T_A = 25°C (unless otherwise noted)



图 6-1. Supply Current (I_{CC}, Operating Mode) vs Temperature (T_A) at Four Supply Voltages



图 6-2. Supply Current (I_{CC}, Standby Mode) vs Temperature (T_A) at Four Supply Voltages

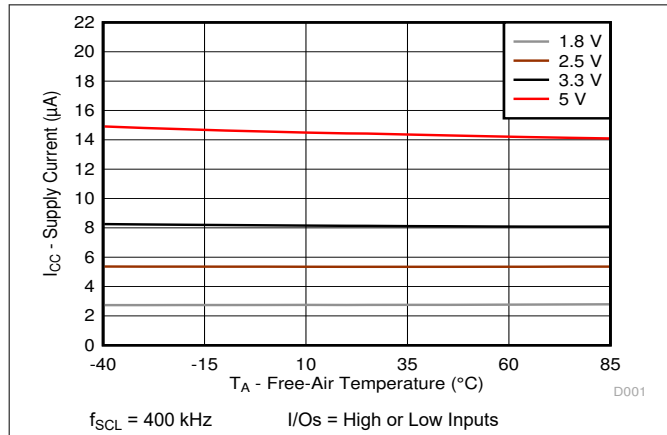

图 6-3. Supply Current (I_{CC}, Operating Mode) vs Supply Voltage (V_{CC})

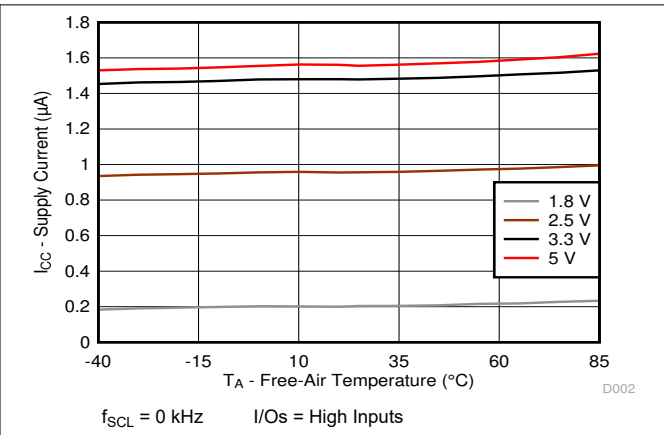

图 6-4. Output Low Voltage (V_{OL}) vs Temperature (T_A) for P-Port I/Os

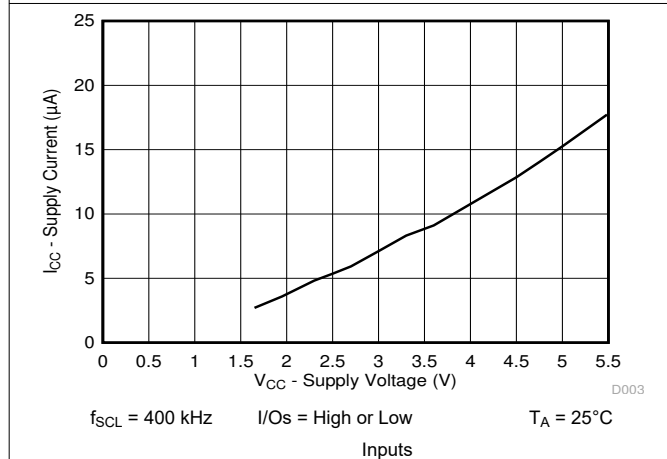

图 6-5. Sink Current (I_{OL}) vs Output Low Voltage (V_{OL}) for P-Ports at Four Supply Voltages

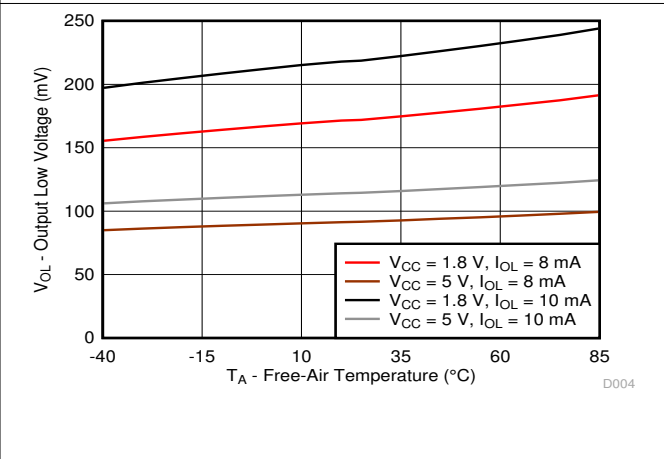

图 6-6. Output High Voltage (V_{CC} - V_{OH}) vs Temperature (T_A) for P-Ports

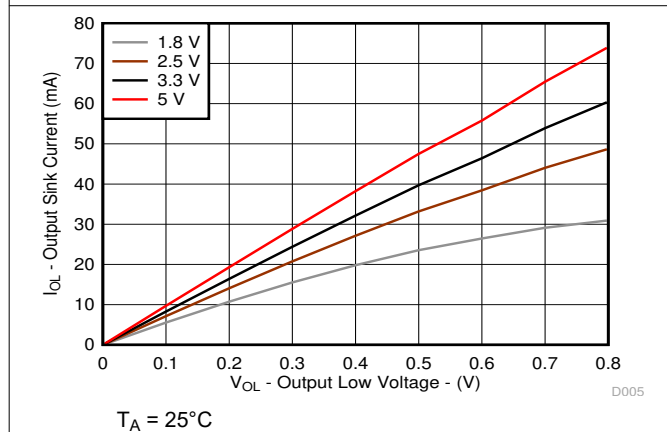

图 6-7. Source Current (I_{OH}) vs Output High Voltage (V_{OH}) for P-Ports at Four Supply Voltages

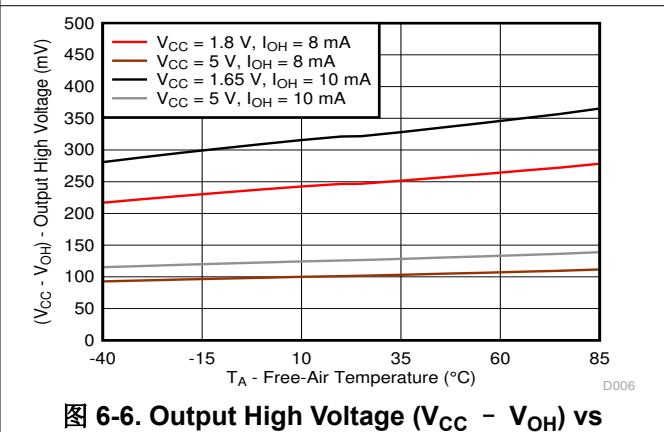

图 6-8. Output High Voltage (V_{OH}) vs Supply Voltage (V_{CC}) for P-Ports

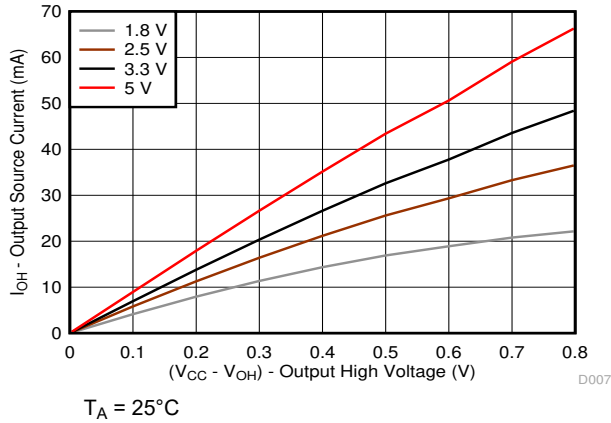

图 6-9. Supply Current (I_{CC}) vs Number of I/Os Held Low (#)

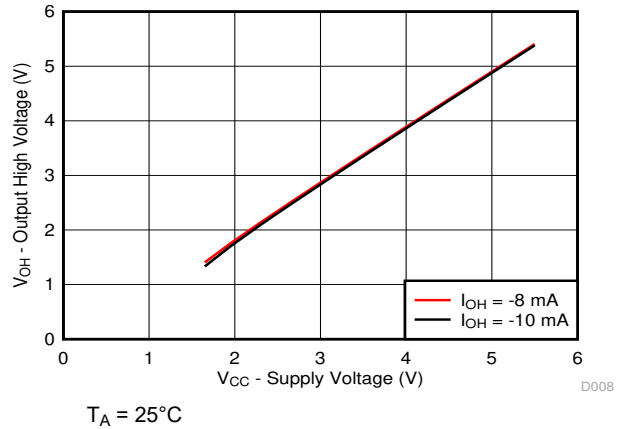

图 6-10. ΔI_{CC} vs Temperature for Different V_{CC} ($V_I = V_{CC} - 0.6 V$)

7 Parameter Measurement Information

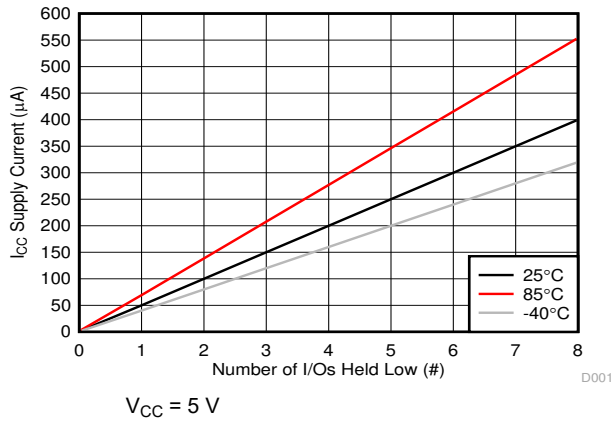

SDA LOAD CONFIGURATION

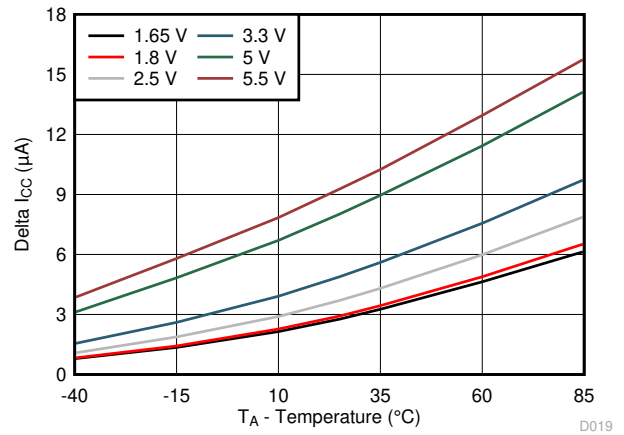
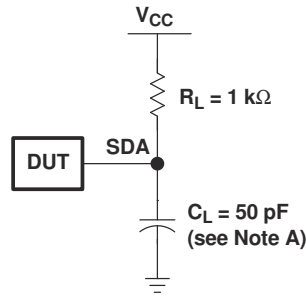
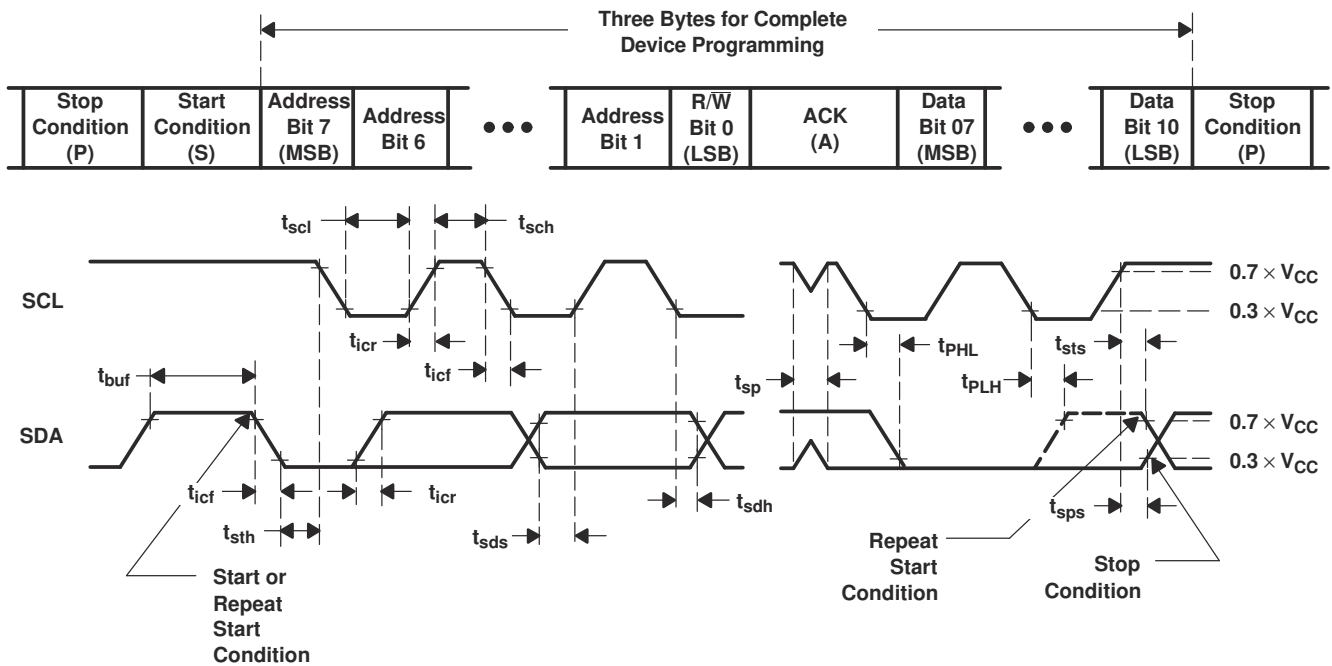

VOLTAGE WAVEFORMS

BYTE	DESCRIPTION
1	I ² C address
2, 3	P-port data

- A. C_L includes probe and jig capacitance.
- B. All inputs are supplied by generators having the following characteristics: $PRR \leq 10 \text{ MHz}$, $Z_O = 50 \Omega$, $t_r/t_f \leq 30 \text{ ns}$.
- C. All parameters and waveforms are not applicable to all devices.

图 7-1. I²C Interface Load Circuit And Voltage Waveforms

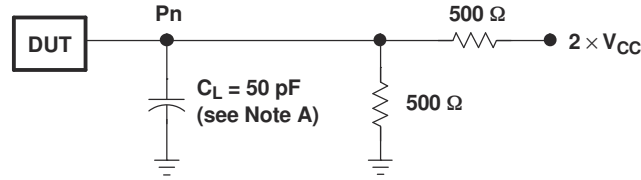

P-PORT LOAD CONFIGURATION

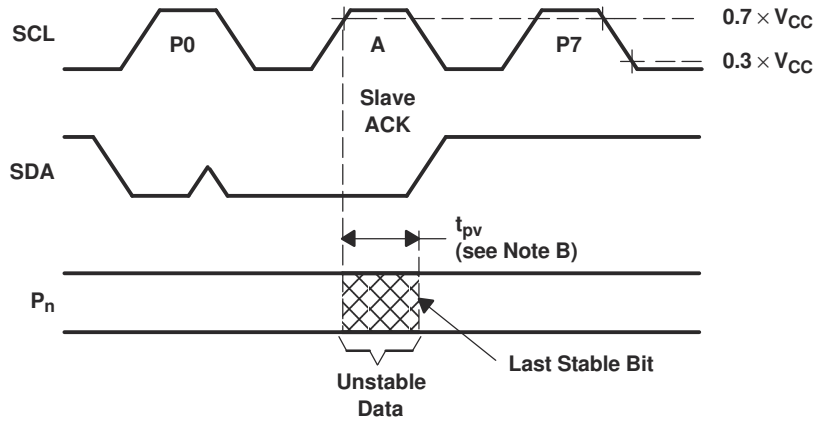

WRITE MODE ($R/\bar{W} = 0$)

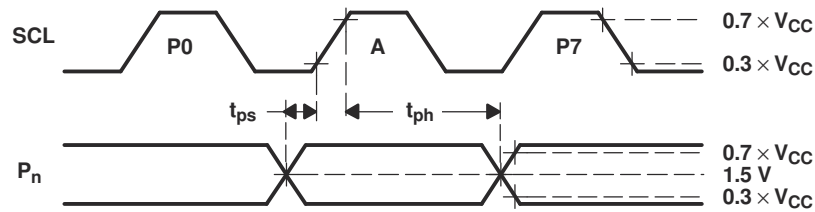

READ MODE ($R/\bar{W} = 1$)

- A. C_L includes probe and jig capacitance.
- B. t_{pv} is measured from $0.7 \times V_{CC}$ on SCL to 50% I/O pin output.
- C. All inputs are supplied by generators having the following characteristics: $PRR \leq 10$ MHz, $Z_O = 50 \Omega$, $t_r/t_f \leq 30$ ns.
- D. The outputs are measured one at a time, with one transition per measurement.
- E. All parameters and waveforms are not applicable to all devices.

图 7-3. P-Port Load Circuit And Voltage Waveforms

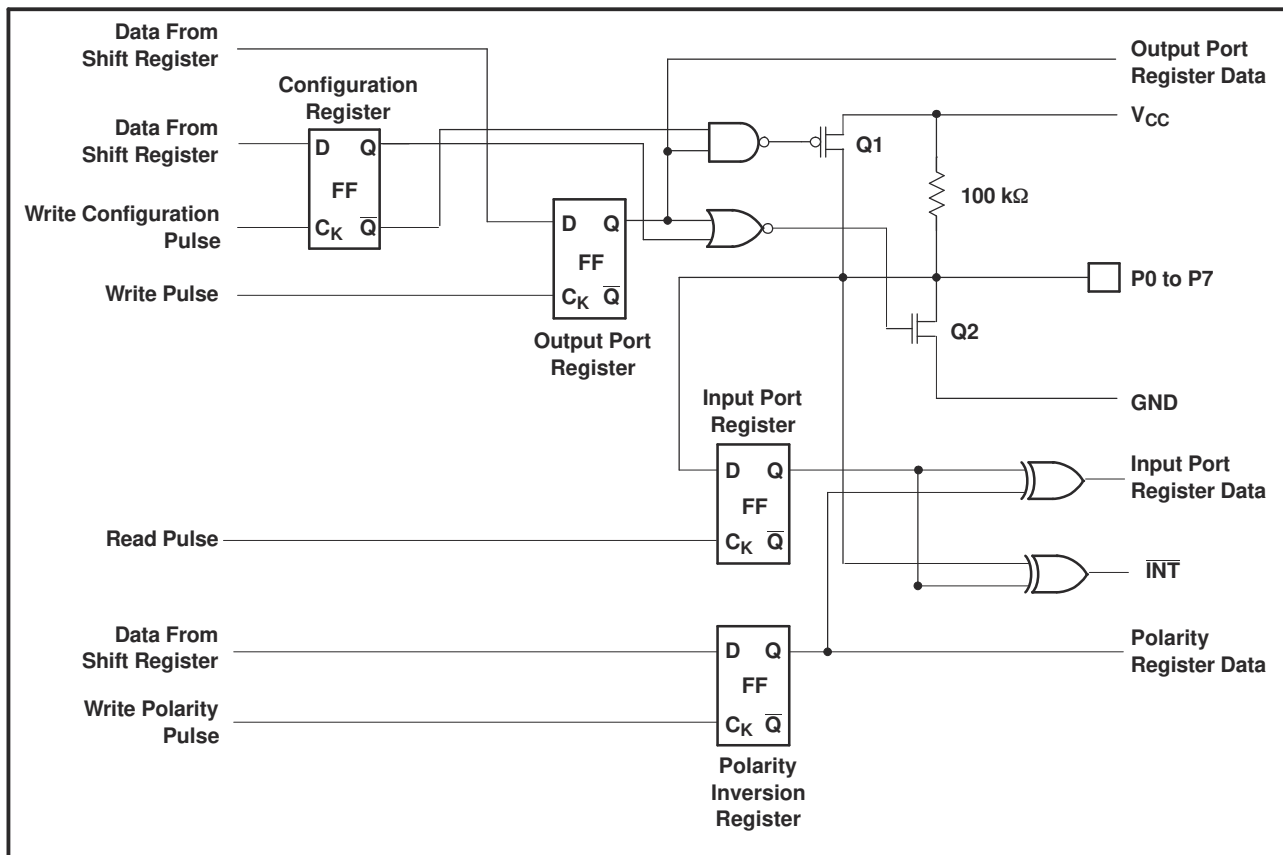

A. At power-on reset, all registers return to default values.

图 8-2. Simplified Schematic Of P0 To P7

8.2 Device Functional Modes

8.2.1 Power-On Reset

When power (from 0 V) is applied to V_{CC} , an internal power-on reset holds the PCA9554A in a reset condition until V_{CC} has reached V_{PORR} . At that point, the reset condition is released and the PCA9554A registers and I²C/SMBus state machine will initialize to their default states. After that, V_{CC} must be lowered to below 0.2 V and then back up to the operating voltage for a power-reset cycle.

8.2.2 I/O Port

When an I/O is configured as an input, FETs Q1 and Q2 (in 图 8-2) are off, which creates a high impedance input with a weak pullup (100 kΩ typ) to V_{CC} . The input voltage may be raised above V_{CC} to a maximum of 5.5 V.

If the I/O is configured as an output, Q1 or Q2 is enabled, depending on the state of the output port register. In this case, there are low impedance paths between the I/O pin and either V_{CC} or GND. The external voltage applied to this I/O pin should not exceed the recommended levels for proper operation.

8.2.3 Interrupt Output (\overline{INT})

An interrupt is generated by any rising or falling edge of the port inputs in the input mode. After time, t_{iv} , the signal \overline{INT} is valid. Resetting the interrupt circuit is achieved when data on the port is changed to the original setting, data is read from the port that generated the interrupt. Resetting occurs in the read mode at the acknowledge (ACK) or not acknowledge (NACK) bit after the rising edge of the SCL signal.

Interrupts that occur during the ACK or NACK clock pulse can be lost (or be very short) due to the resetting of the interrupt during this pulse. Each change of the I/Os after resetting is detected and is transmitted as \overline{INT} . Writing to another device does not affect the interrupt circuit, and a pin configured as an output cannot cause an

interrupt. Changing an I/O from an output to an input may cause a false interrupt to occur, if the state of the pin does not match the contents of the Input Port register. Because each 8-pin port is read independently, the interrupt caused by port 0 is not cleared by a read of port 1 or vice versa.

The $\overline{\text{INT}}$ output has an open-drain structure and requires pull-up resistor to V_{CC} .

8.2.3.1 Interrupt Errata

8.2.3.1.1 Description

The INT will be improperly de-asserted if the following two conditions occur:

1. The last I²C command byte (register pointer) written to the device was 00h.

Note

This generally means the last operation with the device was a Read of the input register. However, the command byte may have been written with 00h without ever going on to read the input register. After reading from the device, if no other command byte written, it will remain 00h.

2. Any other slave device on the I²C bus acknowledges an address byte with the R/W bit set high

8.2.3.1.2 System Impact

Can cause improper interrupt handling as the Master will see the interrupt as being cleared.

8.2.3.1.3 System Workaround

Minor software change: User must change command byte to something besides 00h after a Read operation to the PCA9554A device or before reading from another slave device.

Note

Software change will be compatible with other versions (competition and TI redesigns) of this device.

8.3 Programming

8.3.1 I²C Interface

The bidirectional I²C bus consists of the serial clock (SCL) and serial data (SDA) lines. Both lines must be connected to a positive supply through a pullup resistor when connected to the output stages of a device. Data transfer may be initiated only when the bus is not busy.

I²C communication with this device is initiated by a master sending a Start condition, a high-to-low transition on the SDA input/output while the SCL input is high (see [Figure 8-3](#)). After the Start condition, the device address byte is sent, most significant bit (MSB) first, including the data direction bit (R/ \overline{W}).

After receiving the valid address byte, this device responds with an acknowledge (ACK), a low on the SDA input/output during the high of the ACK-related clock pulse. The address inputs (A0 - A2) of the slave device must not be changed between the Start and Stop conditions.

On the I²C bus, only one data bit is transferred during each clock pulse. The data on the SDA line must remain stable during the high pulse of the clock period, as changes in the data line at this time are interpreted as control commands (Start or Stop) (see [Figure 8-4](#)).

A Stop condition, a low-to-high transition on the SDA input/output while the SCL input is high, is sent by the master (see [Figure 8-3](#)).

Any number of data bytes can be transferred from the transmitter to receiver between the Start and Stop conditions. Each byte of eight bits is followed by one ACK bit. The transmitter must release the SDA line before the receiver can send an ACK bit. The device that acknowledges must pull down the SDA line during the ACK clock pulse so that the SDA line is stable low during the high pulse of the ACK-related clock period (see [Figure 8-5](#)). When a slave receiver is addressed, it must generate an ACK after each byte is received. Similarly, the master must generate an ACK after each byte that it receives from the slave transmitter. Setup and hold times must be met to ensure proper operation.

A master receiver will signal an end of data to the slave transmitter by not generating an acknowledge (NACK) after the last byte has been clocked out of the slave. This is done by the master receiver by holding the SDA line high. In this event, the transmitter must release the data line to enable the master to generate a Stop condition.



图 8-3. Definition Of Start And Stop Conditions



图 8-4. Bit Transfer

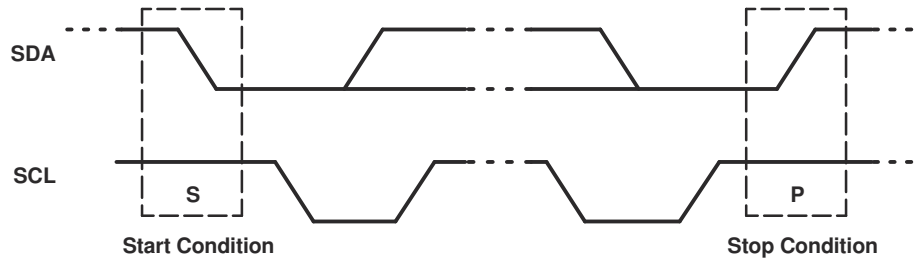

图 8-5. Acknowledgment On The I²C Bus

8.3.2 Register Map

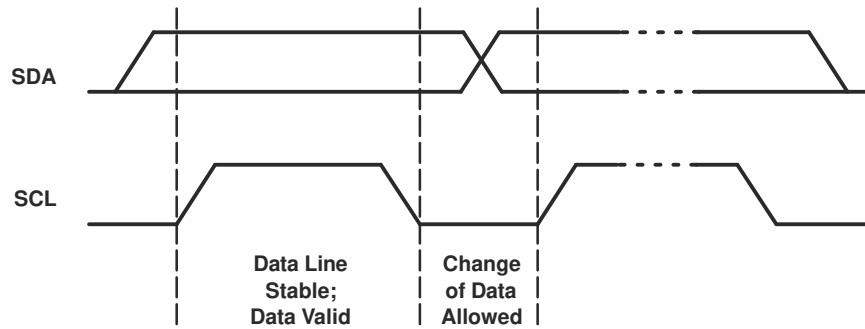
表 8-1. Interface Definition

BYTE	BIT							
	7 (MSB)	6	5	4	3	2	1	0 (LSB)
I ² C slave address	L	H	H	H	A2	A1	A0	R/W
Px I/O data bus	P7	P6	P5	P4	P3	P2	P1	P0

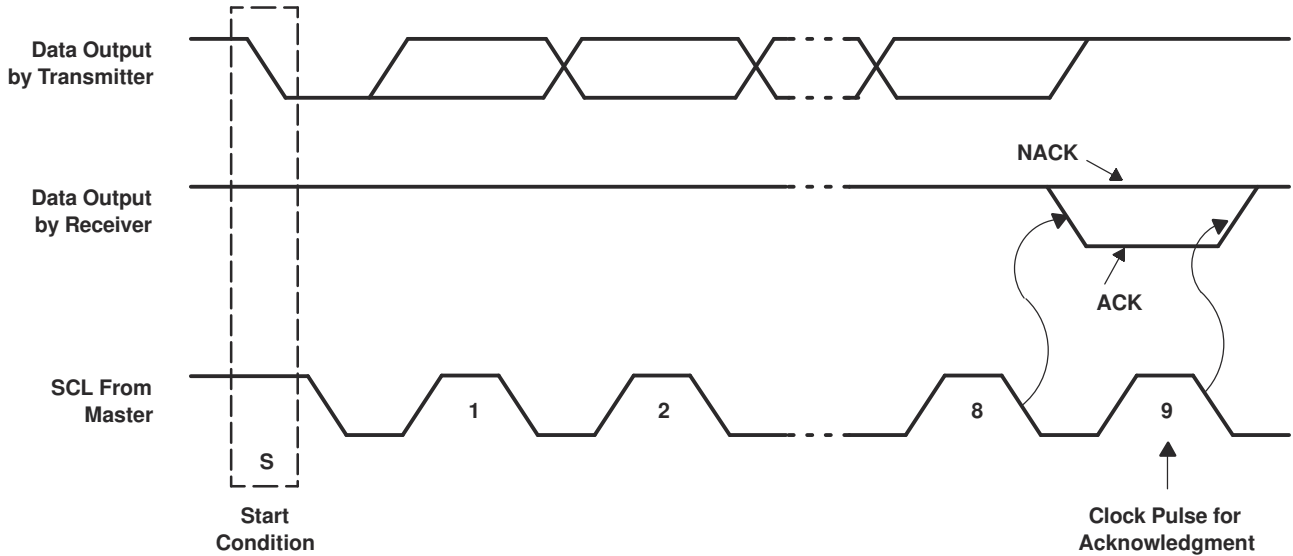
8.3.2.1 Device Address

图 8-6 shows the address byte for the PCA9554A.



图 8-6. Pca9554a Address

表 8-2. Address Reference

INPUTS			I ² C BUS SLAVE ADDRESS
A2	A1	A0	
L	L	L	56 (decimal), 38 (hexadecimal)
L	L	H	57 (decimal), 39 (hexadecimal)
L	H	L	58 (decimal), 3A (hexadecimal)
L	H	H	59 (decimal), 3B (hexadecimal)
H	L	L	60 (decimal), 3C (hexadecimal)
H	L	H	61 (decimal), 3D (hexadecimal)
H	H	L	62 (decimal), 3E (hexadecimal)
H	H	H	63 (decimal), 3F (hexadecimal)

The last bit of the slave address defines the operation (read or write) to be performed. When it is high (1), a read is selected. A low (0) selects a write operation.

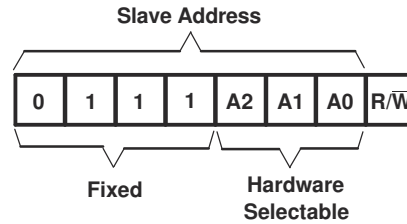
8.3.2.2 Control Register And Command Byte

Following the successful acknowledgment of the address byte, the bus master sends a command byte that is stored in the control register in the PCA9554A. Two bits of this command byte state the operation (read or write) and the internal register (input, output, polarity inversion or configuration) that will be affected. This register can be written or read through the I²C bus. The command byte is sent only during a write transmission.

Once a command byte has been sent, the register that was addressed continues to be accessed by reads until a new command byte has been sent.



图 8-7. Control Register Bits

表 8-3. Command Byte

CONTROL REGISTER BITS		COMMAND BYTE (HEX)	REGISTER	PROTOCOL	POWER-UP DEFAULT
B1	B0				
0	0	0x00	Input Port	Read byte	XXXX XXXX
0	1	0x01	Output Port	Read/write byte	1111 1111
1	0	0x02	Polarity Inversion	Read/write byte	0000 0000
1	1	0x03	Configuration	Read/write byte	1111 1111

8.3.2.3 Register Descriptions

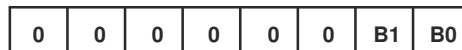
The Input Port register (register 0) reflects the incoming logic levels of the pins, regardless of whether the pin is defined as an input or an output by the Configuration register. It only acts on read operation. Writes to these registers have no effect. The default value, X, is determined by the externally applied logic level.

Before a read operation, a write transmission is sent with the command byte to let the I²C device know that the Input Port register will be accessed next.

表 8-4. Register 0 (Input Port Register)

BIT	I7	I6	I5	I4	I3	I2	I1	I0
DEFAULT	X	X	X	X	X	X	X	X

The Output Port register (register 1) shows the outgoing logic levels of the pins defined as outputs by the Configuration register. Bit values in this register have no effect on pins defined as inputs. In turn, reads from this register reflect the value that is in the flip-flop controlling the output selection, not the actual pin value.

表 8-5. Register 1 (Output Port Register)

BIT	O7	O6	O5	O4	O3	O2	O1	O0
DEFAULT	1	1	1	1	1	1	1	1

The Polarity Inversion register (register 2) allows polarity inversion of pins defined as inputs by the Configuration register. If a bit in this register is set (written with 1), the corresponding port pin polarity is inverted. If a bit in this register is cleared (written with a 0), the corresponding port pin original polarity is retained.

表 8-6. Register 2 (Polarity Inversion Register)

BIT	N7	N6	N5	N4	N3	N2	N1	N0
DEFAULT	0	0	0	0	0	0	0	0

The Configuration register (register 3) configures the directions of the I/O pins. If a bit in this register is set to 1, the corresponding port pin is enabled as an input with high impedance output driver. If a bit in this register is cleared to 0, the corresponding port pin is enabled as an output.

表 8-7. Register 3 (Configuration Register)

BIT	C7	C6	C5	C4	C3	C2	C1	C0
DEFAULT	1	1	1	1	1	1	1	1

8.3.2.4 Bus Transactions

Data is exchanged between the master and PCA9554A through write and read commands.

8.3.2.4.1 Writes

Data is transmitted to the PCA9554A by sending the device address and setting the least-significant bit to a logic 0 (see Figure 8-6 for device address). The command byte is sent after the address and determines which register receives the data that follows the command byte (see Figure 8-8 and Figure 8-9). There is no limitation on the number of data bytes sent in one write transmission.



图 8-8. Write To Output Port Register



图 8-9. Write To Configuration Or Polarity Inversion Registers

8.3.2.4.2 Reads

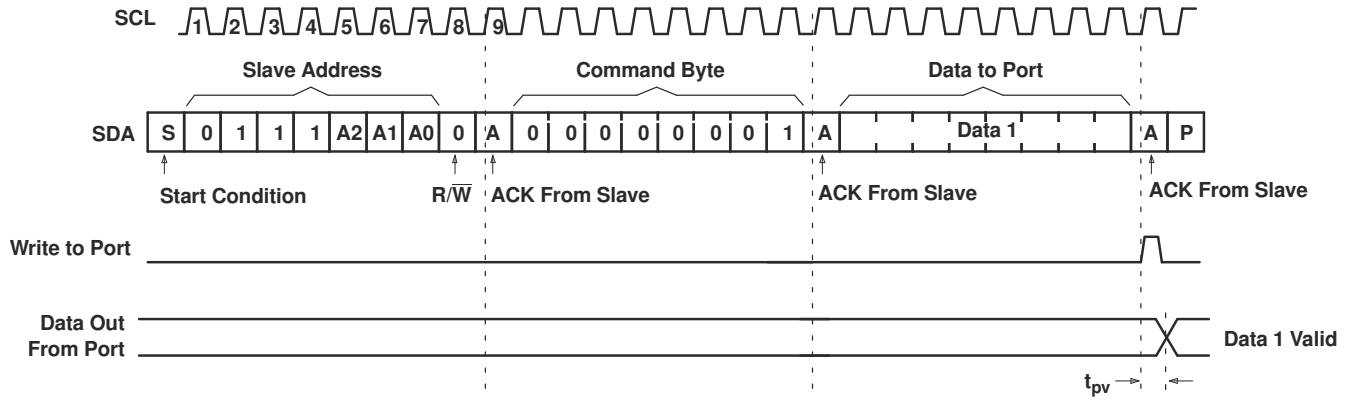
The bus master first must send the PCA9554A address with the least significant bit (LSB) set to a logic 0 (see [图 8-6](#) for device address). The command byte is sent after the address and determines which register is accessed. After a restart, the device address is sent again, but this time the LSB is set to a logic 1. Data from the register defined by the command byte then is sent by the PCA9554A (see [图 8-10](#) and [图 8-11](#)). After a restart, the value of the register defined by the command byte matches the register being accessed when the restart occurred. Data is clocked into the register on the rising edge of the ACK clock pulse. There is no limitation on the number of data bytes received in one read transmission, but when the final byte is received, the bus master must not acknowledge the data.

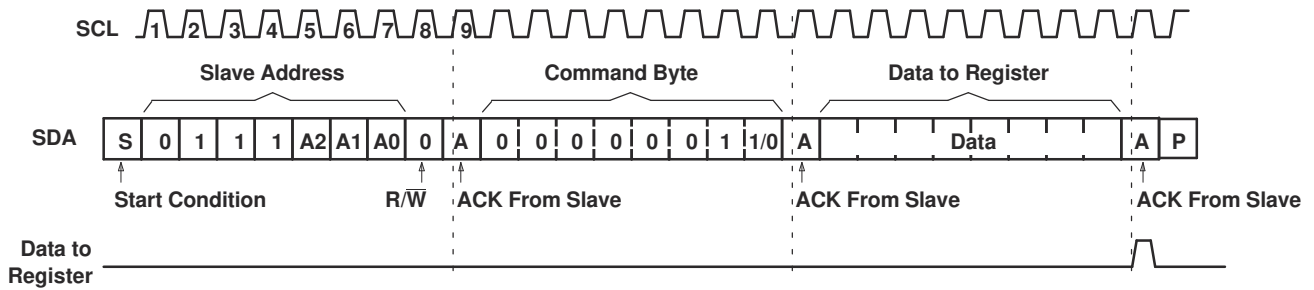

图 8-10. Read From Register



- A. This figure assumes the command byte has previously been programmed with 00h.
- B. Transfer of data can be stopped at any moment by a Stop condition.
- C. This figure eliminates the command byte transfer, a restart, and slave address call between the initial slave address call and actual data transfer from the P port. See [图 8-10](#) for these details.

图 8-11. Read From Input Port Register

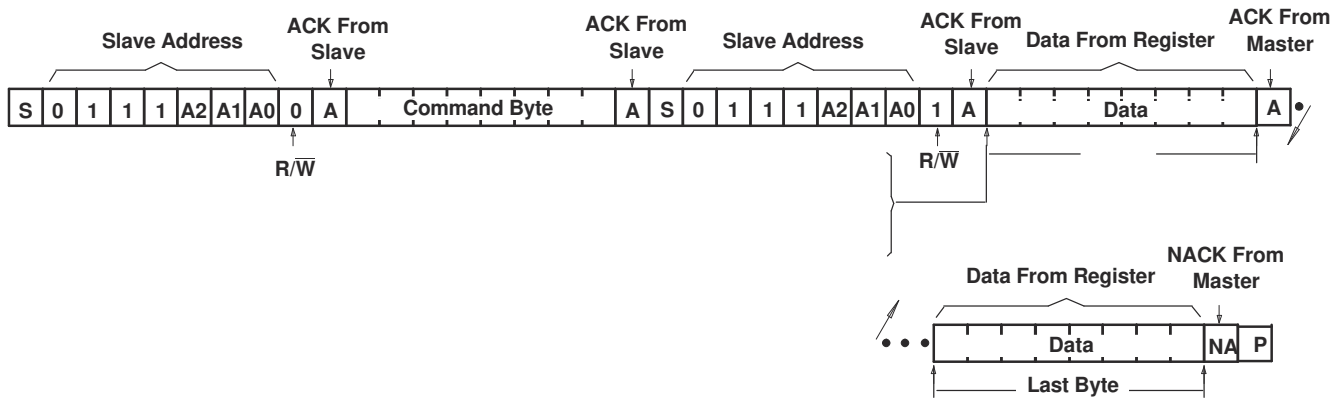
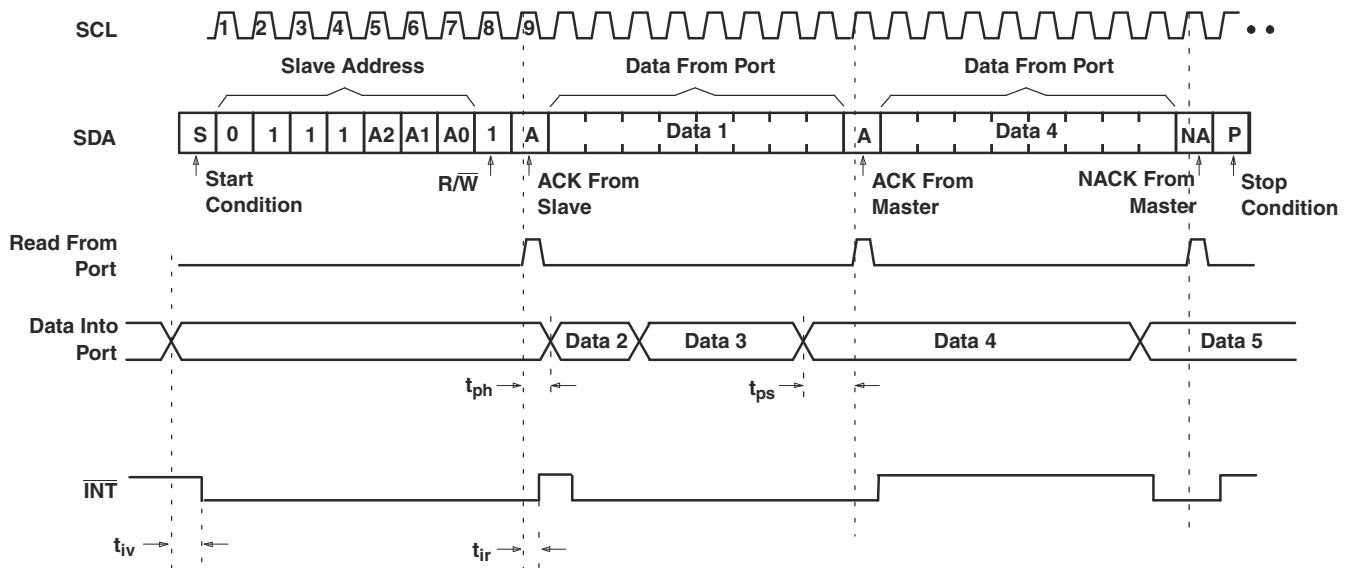
9 Application Information Disclaimer

Note

Information in the following applications sections is not part of the TI component specification, and TI does not warrant its accuracy or completeness. TI's customers are responsible for determining suitability of components for their purposes, as well as validating and testing their design implementation to confirm system functionality.

9.1 Application Information

9.1.1 Typical Application

Figure 9-1 shows an application in which the PCA9554A can be used.

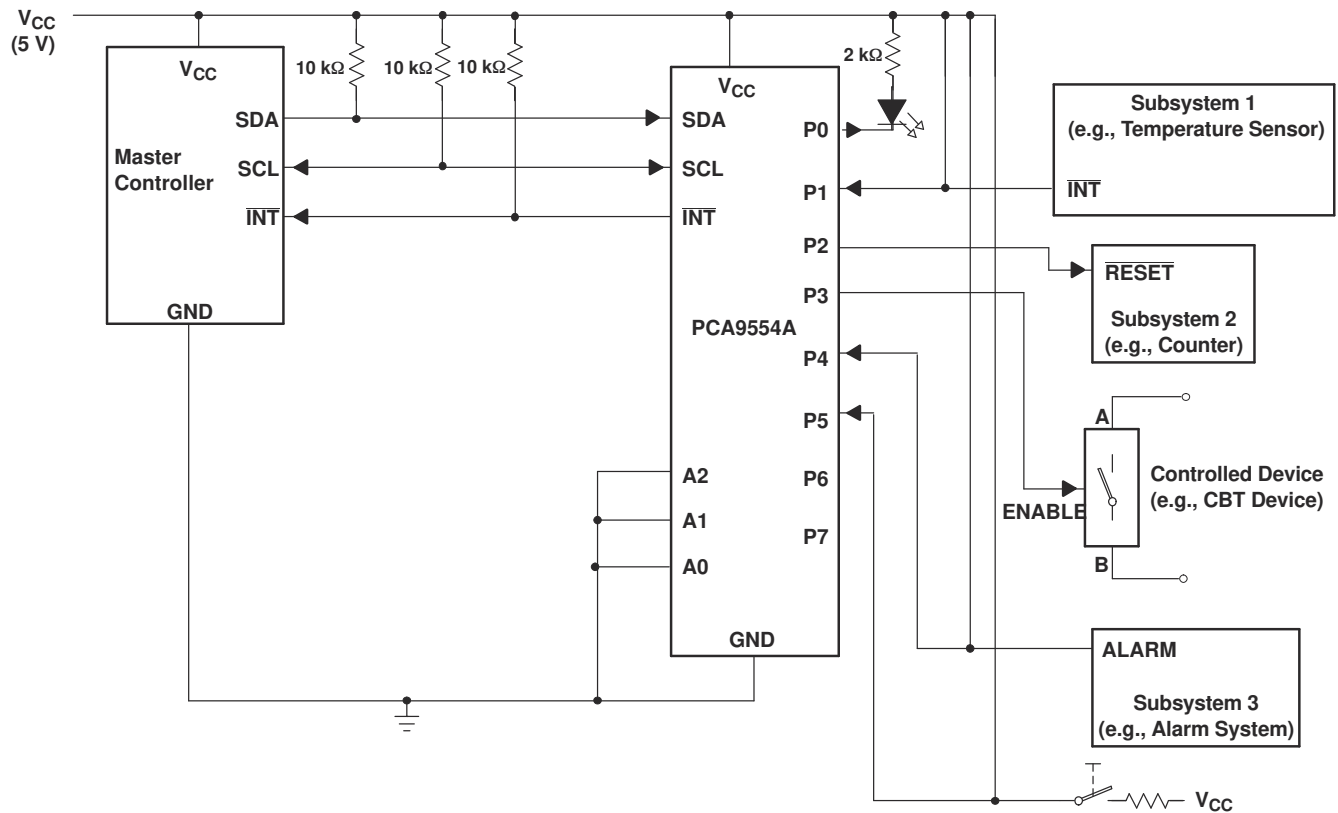

- A. Device address is configured as 0111000 for this example.
- B. P0, P2, and P3 are configured as outputs.
- C. P1, P4, and P5 are configured as inputs.
- D. P6 and P7 are not used and have internal 100-kΩ pullup resistors to protect them from floating.

Figure 9-1. Typical Application

9.1.1.1 Detailed Design Procedure

9.1.1.1.1 Minimizing I_{CC} When I/Os Control Leds

When the I/Os are used to control LEDs, they are normally connected to V_{CC} through a resistor as shown in [Figure 9-1](#). Because the LED acts as a diode, when the LED is off, the I/O V_{IN} is about 1.2 V less than V_{CC} . The supply current, I_{CC} , increases as V_{IN} becomes lower than V_{CC} and is specified as ΔI_{CC} in *Electrical Characteristics*.

For battery-powered applications, it is essential that the voltage of I/O pins is greater than or equal to V_{CC} when the LED is off to minimize current consumption. [Figure 9-2](#) shows a high-value resistor in parallel with the LED. [Figure 9-3](#) shows V_{CC} less than the LED supply voltage by at least 1.2 V. Both of these methods maintain the I/O V_{IN} at or above V_{CC} and prevents additional supply-current consumption when the LED is off.



图 9-2. High-Value Resistor In Parallel With The Led



图 9-3. Device Supplied By A Lower Voltage

10 Power Supply Recommendations

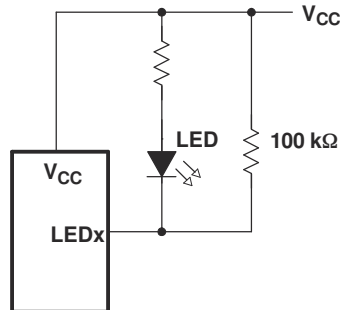
10.1 Power-On Reset Requirements

In the event of a glitch or data corruption, PCA9554A can be reset to its default conditions by using the power-on reset feature. Power-on reset requires that the device go through a power cycle to be completely reset. This reset also happens when the device is powered on for the first time in an application.

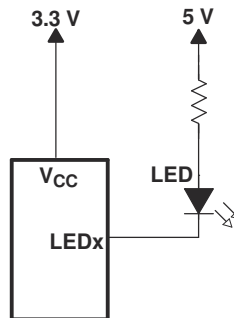
The two types of power-on reset are shown in 图 10-1 and 图 10-2.



图 10-1. V_{CC} Is Lowered Below 0.2 V Or 0 V And Then Ramped Up To V_{CC}



图 10-2. V_{CC} Is Lowered Below The Por Threshold, Then Ramped Back Up To V_{CC}

表 10-1 specifies the performance of the power-on reset feature for PCA9554A for both types of power-on reset.

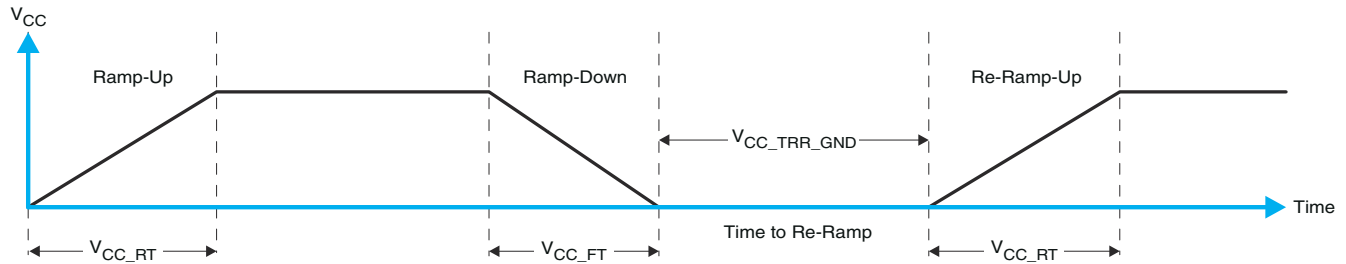
表 10-1. Recommended Supply Sequencing And Ramp Rates⁽¹⁾

PARAMETER			MIN	TYP	MAX	UNIT
V_{CC_FT}	Fall rate	See 图 10-1	1		100	ms
V_{CC_RT}	Rise rate	See 图 10-1	0.01		100	ms
$V_{CC_TRR_GND}$	Time to re-ramp (when V_{CC} drops to GND)	See 图 10-1	0.001			ms
$V_{CC_TRR_POR50}$	Time to re-ramp (when V_{CC} drops to $V_{POR_MIN} - 50$ mV)	See 图 10-2	0.001			ms
V_{CC_GH}	Level that V_{CCP} can glitch down to, but not cause a functional disruption when $V_{CCX_GW} = 1 \mu s$	See 图 10-3			1.2	V
V_{CC_GW}	Glitch width that will not cause a functional disruption when $V_{CCX_GH} = 0.5 \times V_{CCx}$	See 图 10-3				μs
V_{PORF}	Voltage trip point of POR on falling V_{CC}		0.767		1.144	V
V_{PORR}	Voltage trip point of POR on rising V_{CC}		1.033		1.428	V

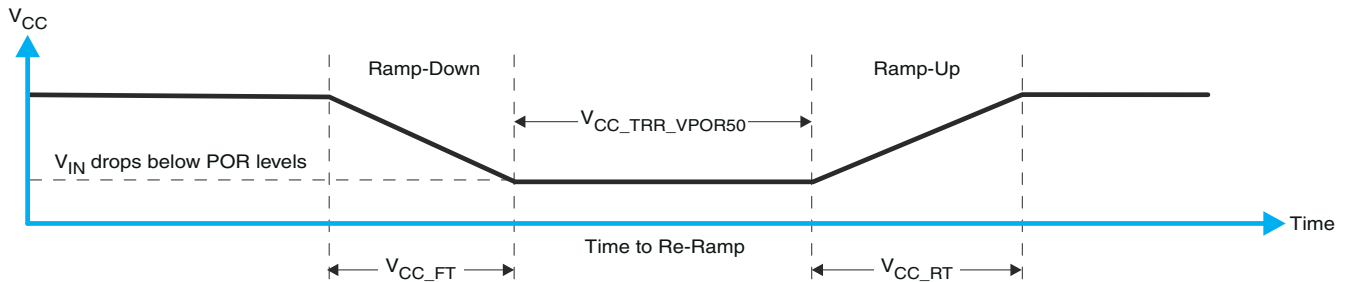
(1) $T_A = -40^\circ C$ to $85^\circ C$ (unless otherwise noted)

Glitches in the power supply can also affect the power-on reset performance of this device. The glitch width (V_{CC_GW}) and height (V_{CC_GH}) are dependent on each other. The bypass capacitance, source impedance, and the device impedance are factors that affect power-on reset performance. 图 10-3 and 表 10-1 provide more information on how to measure these specifications.



图 10-3. Glitch Width And Glitch Height

V_{POR} is critical to the power-on reset. V_{POR} is the voltage level at which the reset condition is released and all the registers and the I²C/SMBus state machine are initialized to their default states. The value of V_{POR} differs based on the V_{CC} being lowered to or from 0. 图 10-4 和 表 10-1 提供更多信息。图 10-4 和 表 10-1 提供更多信息。

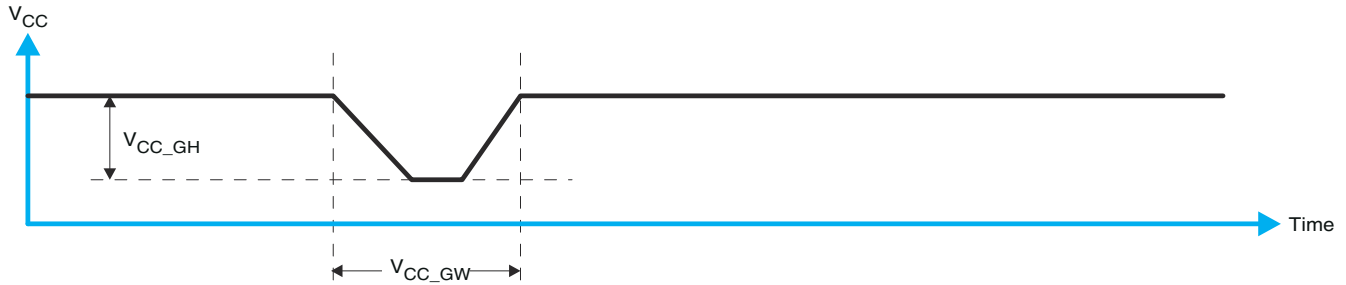

图 10-4. V_{POR}

11 Device and Documentation Support

11.1 支持资源

TI E2E™ 支持论坛是工程师的重要参考资料，可直接从专家获得快速、经过验证的解答和设计帮助。搜索现有解答或提出自己的问题可获得所需的快速设计帮助。

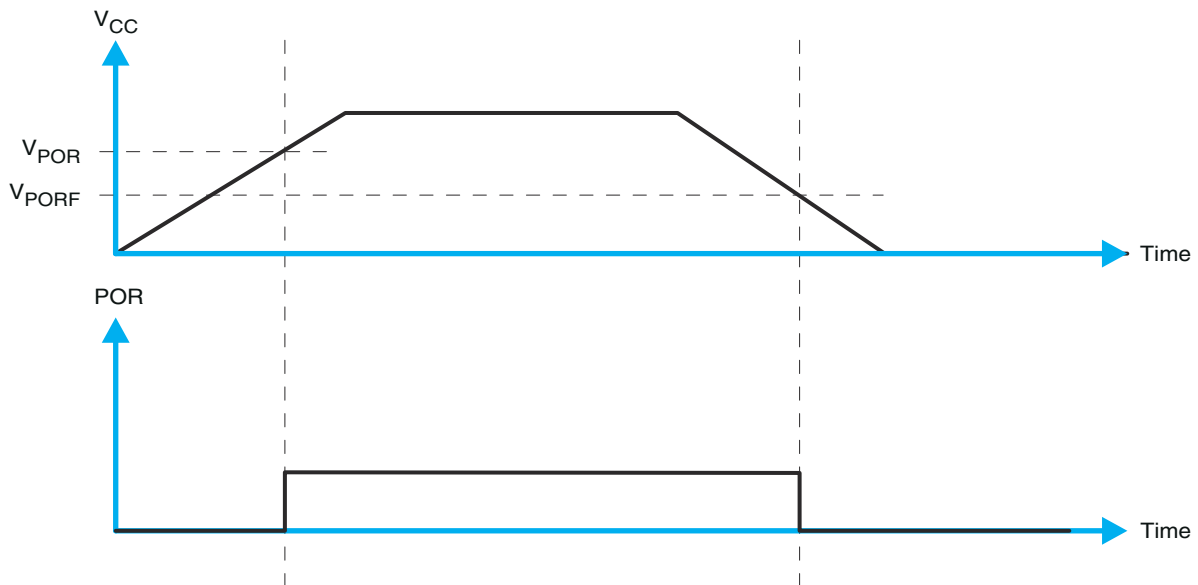
链接的内容由各个贡献者“按原样”提供。这些内容并不构成 TI 技术规范，并且不一定反映 TI 的观点；请参阅 TI 的《使用条款》。

11.2 Trademarks

TI E2E™ is a trademark of Texas Instruments.

所有商标均为其各自所有者的财产。

11.3 静电放电警告



静电放电 (ESD) 会损坏这个集成电路。德州仪器 (TI) 建议通过适当的预防措施处理所有集成电路。如果不遵守正确的处理和安装程序，可能会损坏集成电路。

ESD 的损坏小至导致微小的性能降级，大至整个器件故障。精密的集成电路可能更容易受到损坏，这是因为非常细微的参数更改都可能会导致器件与其发布的规格不相符。

11.4 术语表

[TI 术语表](#) 本术语表列出并解释了术语、首字母缩略词和定义。

12 Mechanical, Packaging, and Orderable Information

The following pages include mechanical, packaging, and orderable information. This information is the most current data available for the designated devices. This data is subject to change without notice and revision of this document. For browser-based versions of this data sheet, refer to the left-hand navigation.

PACKAGING INFORMATION

Orderable part number	Status (1)	Material type (2)	Package Pins	Package qty Carrier	RoHS (3)	Lead finish/ Ball material (4)	MSL rating/ Peak reflow (5)	Op temp (°C)	Part marking (6)
PCA9554ADB	Obsolete	Production	SSOP (DB) 16	-	-	Call TI	Call TI	-40 to 85	PD554A
PCA9554ADBQR	NRND	Production	SSOP (DBQ) 16	-	-	Call TI	Call TI	-40 to 85	
PCA9554ADGV	NRND	Production	TVSOP (DGV) 16	-	-	Call TI	Call TI	-40 to 85	
PCA9554ADGVR	Active	Production	TVSOP (DGV) 16	2000 LARGE T&R	Yes	NIPDAU	Level-1-260C-UNLIM	-40 to 85	PD554A
PCA9554ADGVR.A	Active	Production	TVSOP (DGV) 16	2000 LARGE T&R	Yes	NIPDAU	Level-1-260C-UNLIM	-40 to 85	PD554A
PCA9554ADW	Obsolete	Production	SOIC (DW) 16	-	-	Call TI	Call TI	-40 to 85	PCA9554A
PCA9554ADWR	Obsolete	Production	SOIC (DW) 16	-	-	Call TI	Call TI	-40 to 85	PCA9554A
PCA9554ARGTR	Active	Production	VQFN (RGT) 16	3000 LARGE T&R	Yes	SN	Level-2-260C-1 YEAR	-40 to 85	ZVH
PCA9554ARGTR.A	Active	Production	VQFN (RGT) 16	3000 LARGE T&R	Yes	SN	Level-2-260C-1 YEAR	-40 to 85	ZVH
PCA9554ARGTR.B	Active	Production	VQFN (RGT) 16	3000 LARGE T&R	Yes	SN	Level-2-260C-1 YEAR	-40 to 85	ZVH
PCA9554ARGTRG4	Active	Production	VQFN (RGT) 16	3000 LARGE T&R	Yes	NIPDAU	Level-2-260C-1 YEAR	-40 to 85	ZVH
PCA9554ARGTRG4.A	Active	Production	VQFN (RGT) 16	3000 LARGE T&R	Yes	NIPDAU	Level-2-260C-1 YEAR	-40 to 85	ZVH
PCA9554ARGTRG4.B	Active	Production	VQFN (RGT) 16	3000 LARGE T&R	Yes	NIPDAU	Level-2-260C-1 YEAR	-40 to 85	ZVH
PCA9554ARGVR	Active	Production	VQFN (RGV) 16	2500 LARGE T&R	Yes	NIPDAU	Level-2-260C-1 YEAR	-40 to 85	PD554A
PCA9554ARGVR.A	Active	Production	VQFN (RGV) 16	2500 LARGE T&R	Yes	NIPDAU	Level-2-260C-1 YEAR	-40 to 85	PD554A

(1) **Status:** For more details on status, see our [product life cycle](#).

(2) **Material type:** When designated, preproduction parts are prototypes/experimental devices, and are not yet approved or released for full production. Testing and final process, including without limitation quality assurance, reliability performance testing, and/or process qualification, may not yet be complete, and this item is subject to further changes or possible discontinuation. If available for ordering, purchases will be subject to an additional waiver at checkout, and are intended for early internal evaluation purposes only. These items are sold without warranties of any kind.

(3) **RoHS values:** Yes, No, RoHS Exempt. See the [TI RoHS Statement](#) for additional information and value definition.

(4) **Lead finish/Ball material:** Parts may have multiple material finish options. Finish options are separated by a vertical ruled line. Lead finish/Ball material values may wrap to two lines if the finish value exceeds the maximum column width.

(5) **MSL rating/Peak reflow:** The moisture sensitivity level ratings and peak solder (reflow) temperatures. In the event that a part has multiple moisture sensitivity ratings, only the lowest level per JEDEC standards is shown. Refer to the shipping label for the actual reflow temperature that will be used to mount the part to the printed circuit board.

(6) **Part marking:** There may be an additional marking, which relates to the logo, the lot trace code information, or the environmental category of the part.

Multiple part markings will be inside parentheses. Only one part marking contained in parentheses and separated by a "-" will appear on a part. If a line is indented then it is a continuation of the previous line and the two combined represent the entire part marking for that device.

Important Information and Disclaimer: The information provided on this page represents TI's knowledge and belief as of the date that it is provided. TI bases its knowledge and belief on information provided by third parties, and makes no representation or warranty as to the accuracy of such information. Efforts are underway to better integrate information from third parties. TI has taken and continues to take reasonable steps to provide representative and accurate information but may not have conducted destructive testing or chemical analysis on incoming materials and chemicals. TI and TI suppliers consider certain information to be proprietary, and thus CAS numbers and other limited information may not be available for release.

In no event shall TI's liability arising out of such information exceed the total purchase price of the TI part(s) at issue in this document sold by TI to Customer on an annual basis.

TAPE AND REEL INFORMATION

QUADRANT ASSIGNMENTS FOR PIN 1 ORIENTATION IN TAPE

*All dimensions are nominal

Device	Package Type	Package Drawing	Pins	SPQ	Reel Diameter (mm)	Reel Width W1 (mm)	A0 (mm)	B0 (mm)	K0 (mm)	P1 (mm)	W (mm)	Pin1 Quadrant
PCA9554ADGVR	TVSOP	DGV	16	2000	330.0	12.4	6.8	4.0	1.6	8.0	12.0	Q1
PCA9554ARGTR	VQFN	RGT	16	3000	330.0	12.4	3.3	3.3	1.1	8.0	12.0	Q2
PCA9554ARGTRG4	VQFN	RGT	16	3000	330.0	12.4	3.3	3.3	1.1	8.0	12.0	Q2
PCA9554ARGVR	VQFN	RGV	16	2500	330.0	12.4	4.25	4.25	1.15	8.0	12.0	Q2

TAPE AND REEL BOX DIMENSIONS

*All dimensions are nominal

Device	Package Type	Package Drawing	Pins	SPQ	Length (mm)	Width (mm)	Height (mm)
PCA9554ADGVR	TVSOP	DGV	16	2000	353.0	353.0	32.0
PCA9554ARGTR	VQFN	RGT	16	3000	367.0	367.0	35.0
PCA9554ARGTRG4	VQFN	RGT	16	3000	367.0	367.0	35.0
PCA9554ARGVR	VQFN	RGV	16	2500	353.0	353.0	32.0

RGT 16

GENERIC PACKAGE VIEW

VQFN - 1 mm max height

PLASTIC QUAD FLATPACK - NO LEAD

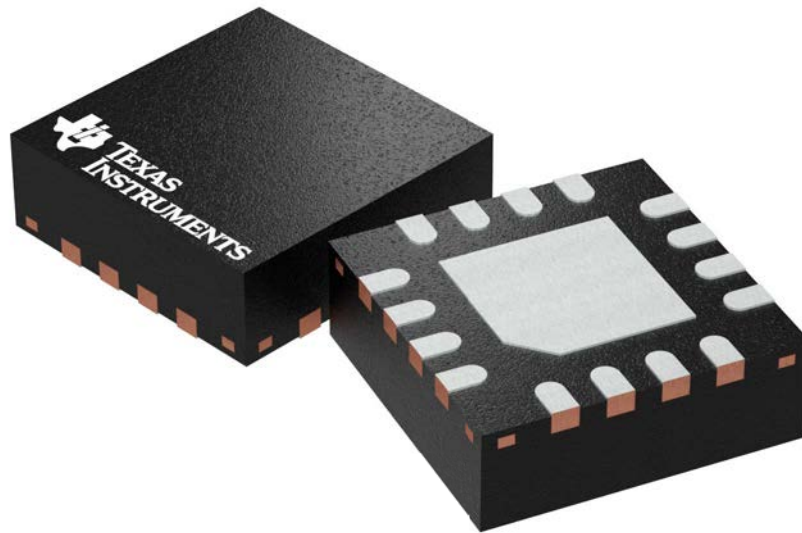

Images above are just a representation of the package family, actual package may vary.
Refer to the product data sheet for package details.

4203495/1

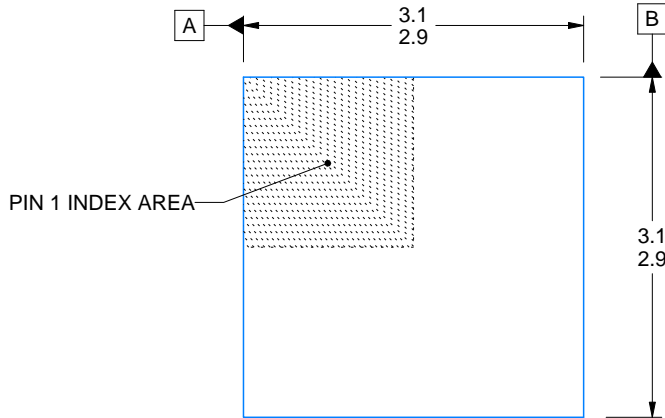
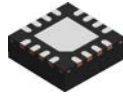

SIDE WALL METAL THICKNESS DIM A	
OPTION 1	OPTION 2
0.1	0.2

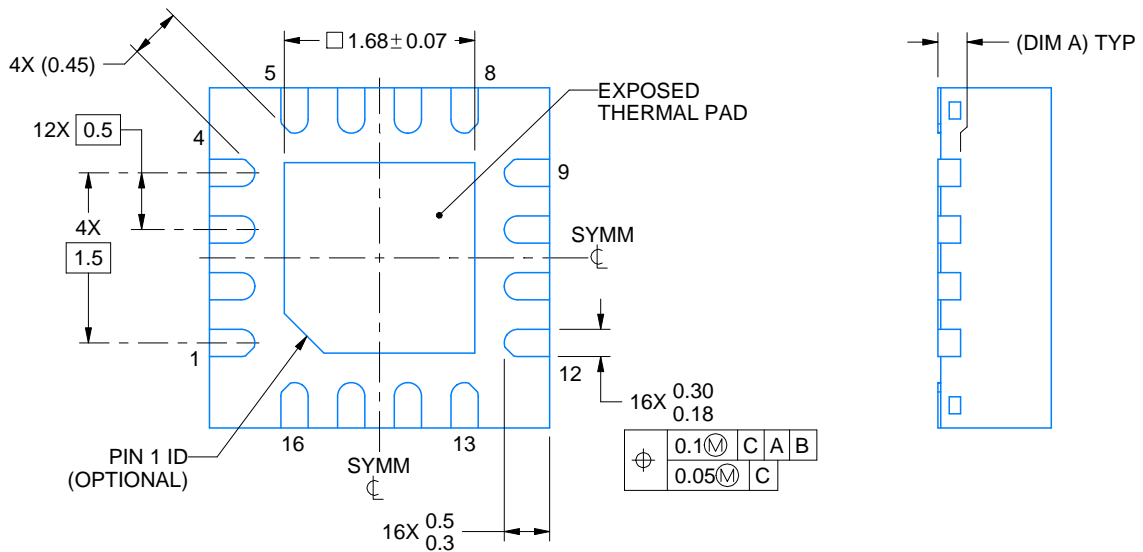
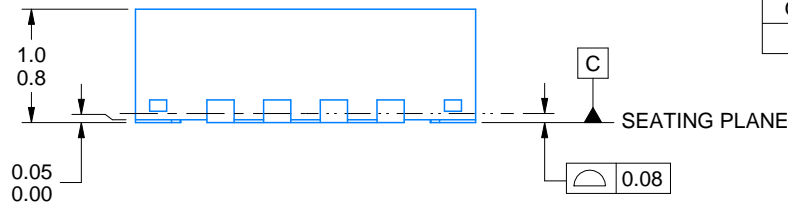

4222419/E 07/2025

NOTES:

1. All linear dimensions are in millimeters. Any dimensions in parenthesis are for reference only. Dimensioning and tolerancing per ASME Y14.5M.
2. This drawing is subject to change without notice.
3. The package thermal pad must be soldered to the printed circuit board for thermal and mechanical performance.

EXAMPLE STENCIL DESIGN

RGT0016C

VQFN - 1 mm max height

PLASTIC QUAD FLATPACK - NO LEAD

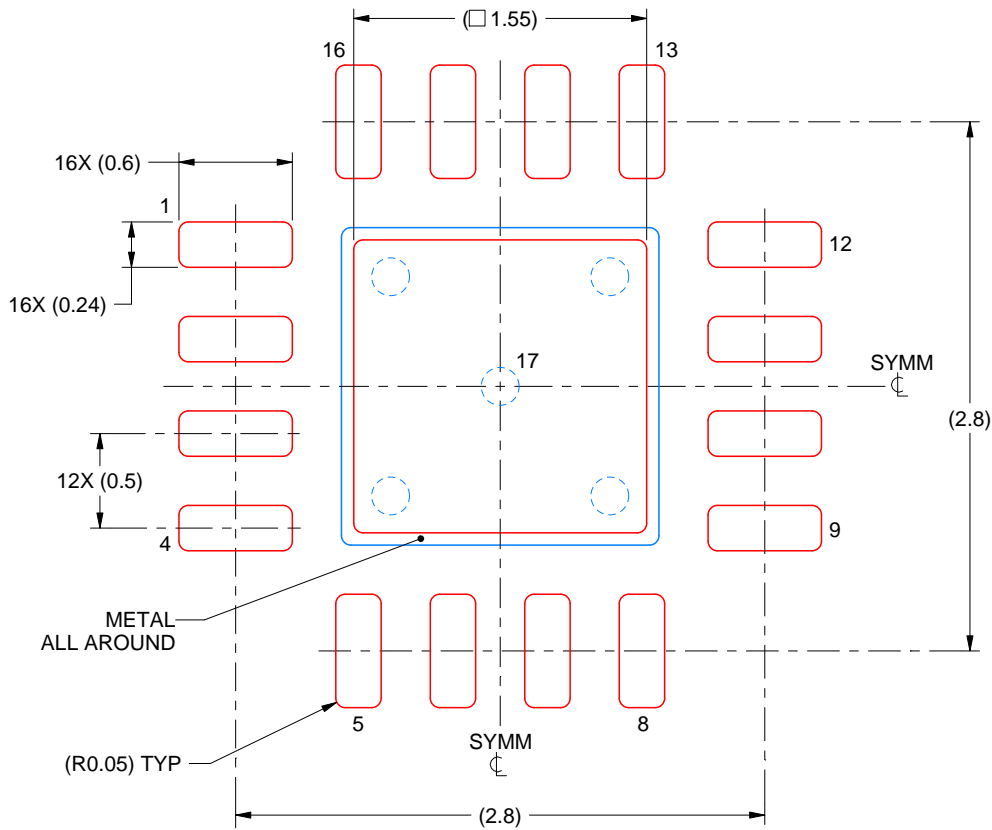

SOLDER PASTE EXAMPLE
BASED ON 0.125 mm THICK STENCIL

EXPOSED PAD 17:
85% PRINTED SOLDER COVERAGE BY AREA UNDER PACKAGE
SCALE:25X

4222419/E 07/2025

NOTES: (continued)

6. Laser cutting apertures with trapezoidal walls and rounded corners may offer better paste release. IPC-7525 may have alternate design recommendations.

GENERIC PACKAGE VIEW

RGV 16

VQFN - 1 mm max height

4 x 4, 0.65 mm pitch

PLASTIC QUAD FLATPACK - NO LEAD

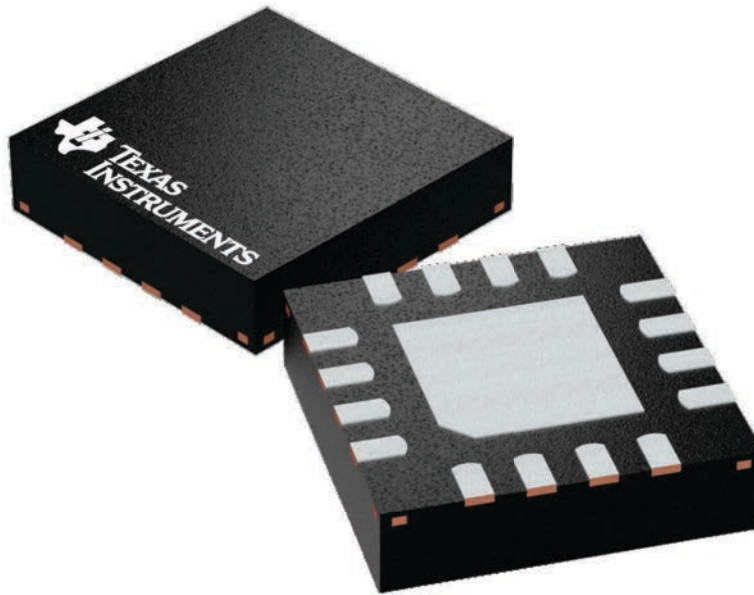

Images above are just a representation of the package family, actual package may vary.
Refer to the product data sheet for package details.

4224748/A

EXAMPLE BOARD LAYOUT

RGV0016A

VQFN - 1 mm max height

PLASTIC QUAD FLATPACK - NO LEAD

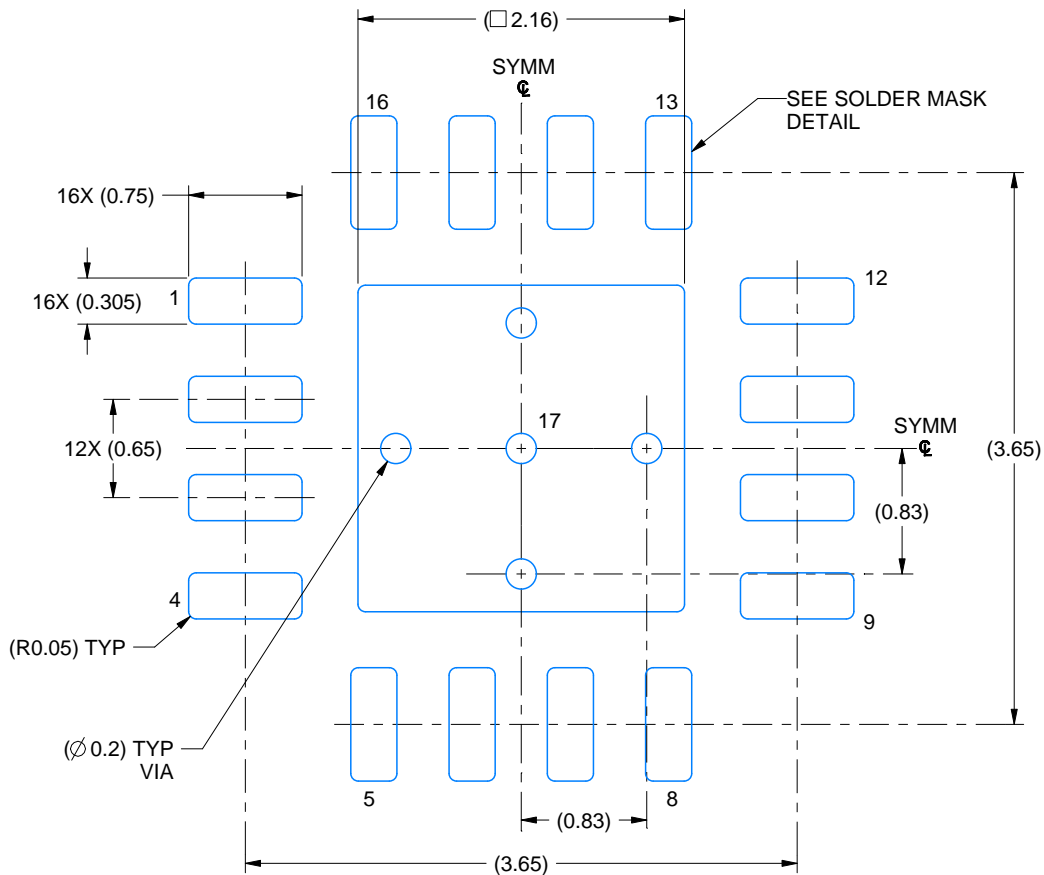

LAND PATTERN EXAMPLE
EXPOSED METAL SHOWN
SCALE: 20X

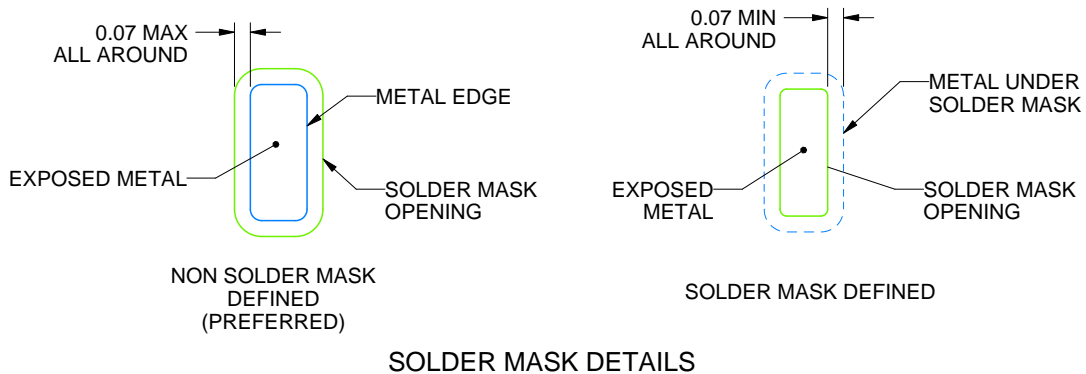

SOLDER MASK DETAILS

4219037/A 06/2019

NOTES: (continued)

- This package is designed to be soldered to a thermal pad on the board. For more information, see Texas Instruments literature number SLUA271 (www.ti.com/lit/sluea271).
- Vias are optional depending on application, refer to device data sheet. If any vias are implemented, refer to their locations shown on this view. It is recommended that vias under paste be filled, plugged or tented.

EXAMPLE STENCIL DESIGN

RGV0016A

VQFN - 1 mm max height

PLASTIC QUAD FLATPACK - NO LEAD

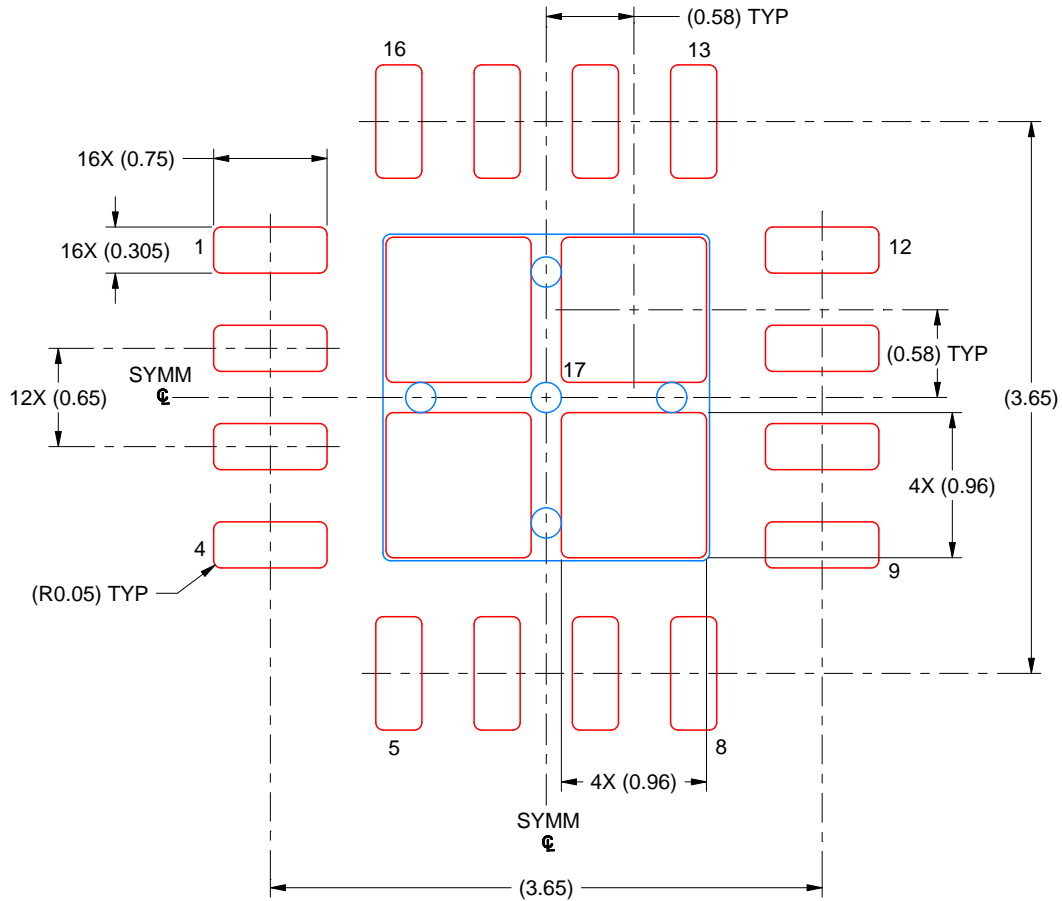

SOLDER PASTE EXAMPLE
BASED ON 0.125 MM THICK STENCIL
SCALE: 20X

EXPOSED PAD 17
79% PRINTED SOLDER COVERAGE BY AREA UNDER PACKAGE

4219037/A 06/2019

NOTES: (continued)

6. Laser cutting apertures with trapezoidal walls and rounded corners may offer better paste release. IPC-7525 may have alternate design recommendations.

DB0016A



PACKAGE OUTLINE

SSOP - 2 mm max height

SMALL OUTLINE PACKAGE

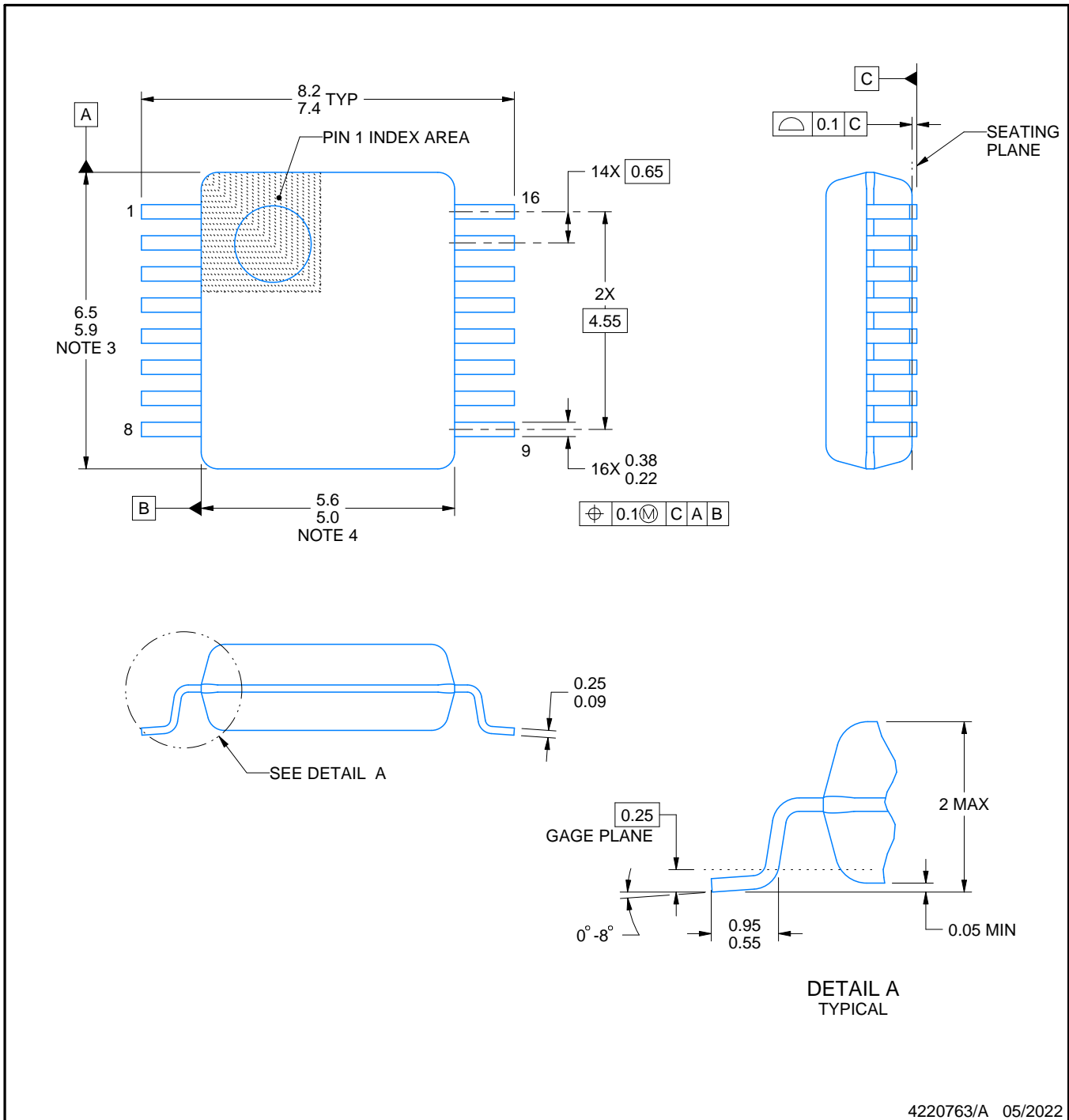

4220763/A 05/2022

NOTES:

- All linear dimensions are in millimeters. Any dimensions in parenthesis are for reference only. Dimensioning and tolerancing per ASME Y14.5M.
- This drawing is subject to change without notice.
- This dimension does not include mold flash, protrusions, or gate burrs. Mold flash, protrusions, or gate burrs shall not exceed 0.15 mm per side.
- Reference JEDEC registration MO-150.

EXAMPLE BOARD LAYOUT

DB0016A

SSOP - 2 mm max height

SMALL OUTLINE PACKAGE

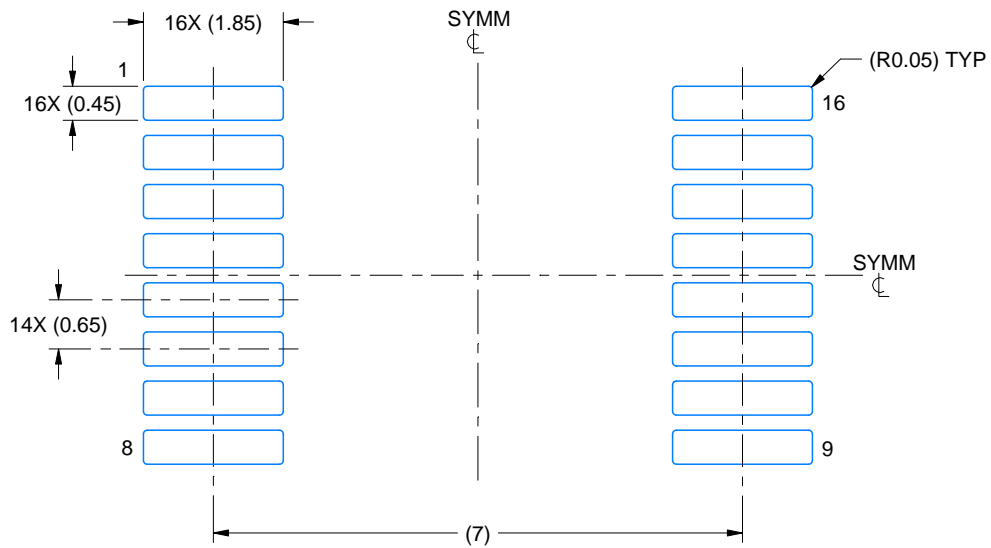

LAND PATTERN EXAMPLE
EXPOSED METAL SHOWN
SCALE: 10X

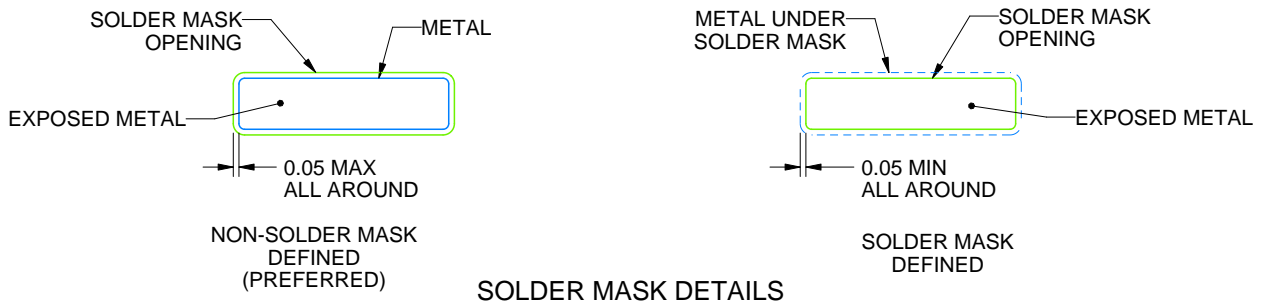

4220763/A 05/2022

NOTES: (continued)

5. Publication IPC-7351 may have alternate designs.
6. Solder mask tolerances between and around signal pads can vary based on board fabrication site.

EXAMPLE STENCIL DESIGN

DB0016A

SSOP - 2 mm max height

SMALL OUTLINE PACKAGE

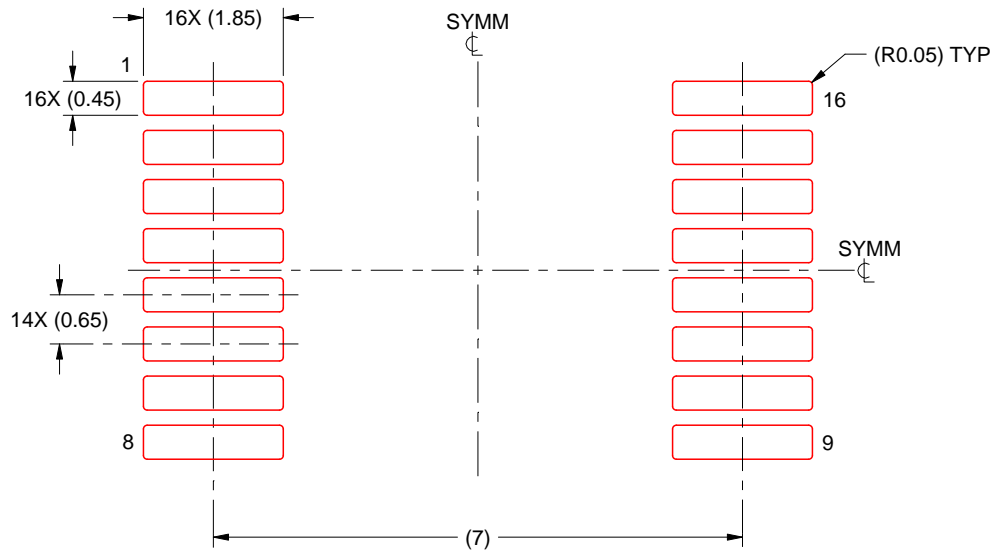

SOLDER PASTE EXAMPLE
BASED ON 0.125 mm THICK STENCIL
SCALE: 10X

4220763/A 05/2022

NOTES: (continued)

7. Laser cutting apertures with trapezoidal walls and rounded corners may offer better paste release. IPC-7525 may have alternate design recommendations.
8. Board assembly site may have different recommendations for stencil design.

GENERIC PACKAGE VIEW

DW 16

SOIC - 2.65 mm max height

7.5 x 10.3, 1.27 mm pitch

SMALL OUTLINE INTEGRATED CIRCUIT

This image is a representation of the package family, actual package may vary.
Refer to the product data sheet for package details.

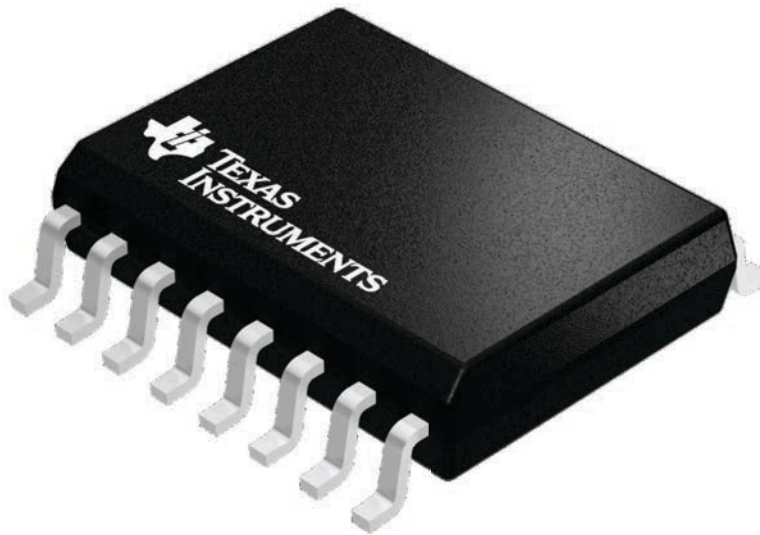

4224780/A

重要通知和免责声明

TI“按原样”提供技术和可靠性数据（包括数据表）、设计资源（包括参考设计）、应用或其他设计建议、网络工具、安全信息和其他资源，不保证没有瑕疵且不做任何明示或暗示的担保，包括但不限于对适销性、与某特定用途的适用性或不侵犯任何第三方知识产权的暗示担保。

这些资源可供使用 TI 产品进行设计的熟练开发人员使用。您将自行承担以下全部责任：(1) 针对您的应用选择合适的 TI 产品，(2) 设计、验证并测试您的应用，(3) 确保您的应用满足相应标准以及任何其他安全、安保法规或其他要求。

这些资源如有变更，恕不另行通知。TI 授权您仅可将这些资源用于研发本资源所述的 TI 产品的相关应用。严禁以其他方式对这些资源进行复制或展示。您无权使用任何其他 TI 知识产权或任何第三方知识产权。对于因您对这些资源的使用而对 TI 及其代表造成的任何索赔、损害、成本、损失和债务，您将全额赔偿，TI 对此概不负责。

TI 提供的产品受 [TI 销售条款](#)、[TI 通用质量指南](#) 或 [ti.com](#) 上其他适用条款或 TI 产品随附的其他适用条款的约束。TI 提供这些资源并不会扩展或以其他方式更改 TI 针对 TI 产品发布的适用的担保或担保免责声明。除非德州仪器 (TI) 明确将某产品指定为定制产品或客户特定产品，否则其产品均为按确定价格收入目录的标准通用器件。

TI 反对并拒绝您可能提出的任何其他或不同的条款。

版权所有 © 2026，德州仪器 (TI) 公司

最后更新日期：2025 年 10 月