

LMZ34202 4.5V 至 42V 输入、2A 电源模块

1 特性

- 完整的集成式电源解决方案可实现小尺寸的薄型设计
- 10mm × 10mm × 4.3mm 封装
- 宽输出电压调节范围 (2.5V 至 7.5V)
- 可调节开关频率 (200kHz 至 1MHz)
- 与外部时钟同步
- 针对轻负载时效率的自动脉冲频率调制 (PFM) 模式
- 可调软启动时间
- 输出电压排序/跟踪
- 电源正常输出
- 可编程欠压锁定 (UVLO)
- 过热热关断保护
- 过流保护 (断续模式)
- 预偏置输出启动
- 工作温度范围: -40°C 至 105°C
- 增强的热性能: 14°C/W
- 符合 EN55022 B 类辐射标准 – 集成屏蔽式电感器
- 使用 LMZ34202 并借助 [WEBENCH® 电源设计器](#) 创建定制设计方案

2 应用

- 工业和电机控制
- 自动测试设备
- 医疗和成像设备
- 高密度电源系统

3 说明

LMZ34202 电源模块是一款易于使用的集成式电源，该模块由带屏蔽式电感器的 2A 直流/直流转换器和无源元件组成，并且采用薄型 QFN 封装。这套整体电源解决方案最少只需采用三个外部组件，同时仍能够调整关键参数以满足特定的设计要求。

QFN 封装易于焊接到印刷电路板上，允许回流焊温度曲线最高达 245°C，并且具有出色的功率耗散能力。LMZ34202 极具灵活性且功能丰富，非常适合为各类器件和系统供电。

器件信息(1)

器件型号	封装	封装尺寸
LMZ34202	QFN (43)	10.00mm x 10.00mm

(1) 如需了解所有可用封装，请参阅数据表末尾的可订购产品附录。

简化应用

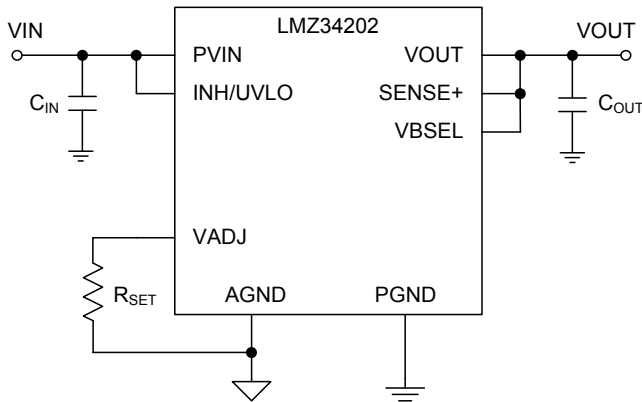

效率与输出电流间的关系

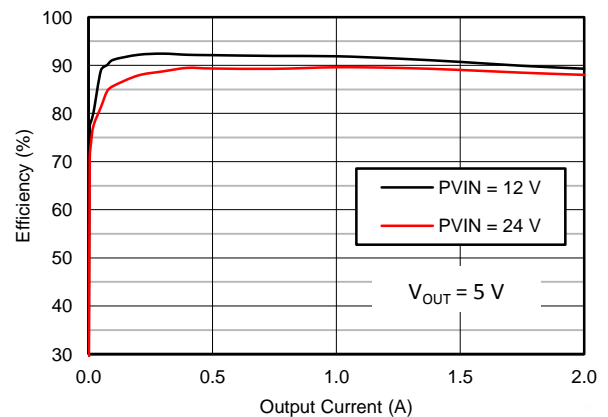

目录

1	特性	1	7.4	Device Functional Modes	20
2	应用	1	8	Application and Implementation	21
3	说明	1	8.1	Application Information	21
4	修订历史记录	2	8.2	Typical Application	21
5	Pin Configuration and Functions	3	9	Power Supply Recommendations	25
6	Specifications	5	10	Layout	26
6.1	Absolute Maximum Ratings	5	10.1	Layout Guidelines	26
6.2	ESD Ratings	5	10.2	Layout Example	26
6.3	Recommended Operating Conditions	5	10.3	EMI	27
6.4	Thermal Information	5	11	器件和文档支持	28
6.5	Electrical Characteristics	6	11.1	器件支持	28
6.6	Switching Characteristics	7	11.2	接收文档更新通知	28
6.7	Typical Characteristics	8	11.3	社区资源	28
6.8	Typical Characteristics (Thermal Derating)	11	11.4	商标	28
7	Detailed Description	12	11.5	静电放电警告	28
7.1	Overview	12	11.6	术语表	28
7.2	Functional Block Diagram	12	12	机械、封装和可订购信息	29
7.3	Feature Description	13			

4 修订历史记录

注：之前版本的页码可能与当前版本有所不同。

Changes from Revision B (April 2018) to Revision C	Page
• 已更改 将允许回流焊温度“最高达 260°C”更改为“最高达 245°C”，从而与绝对最大值表保持一致	1
• 已添加 TI 参考设计顶部导航图标	1

Changes from Revision A (June 2017) to Revision B	Page
• 已添加 针对 LMZ34202 的 WEBENCH® 设计链接	1
• Increased the peak reflow temperature and maximum number of reflows to JEDEC specifications for improved manufacturability	5

Changes from Original (March 2016) to Revision A	Page
• Added peak reflow and maximum number of reflows information	5

5 Pin Configuration and Functions

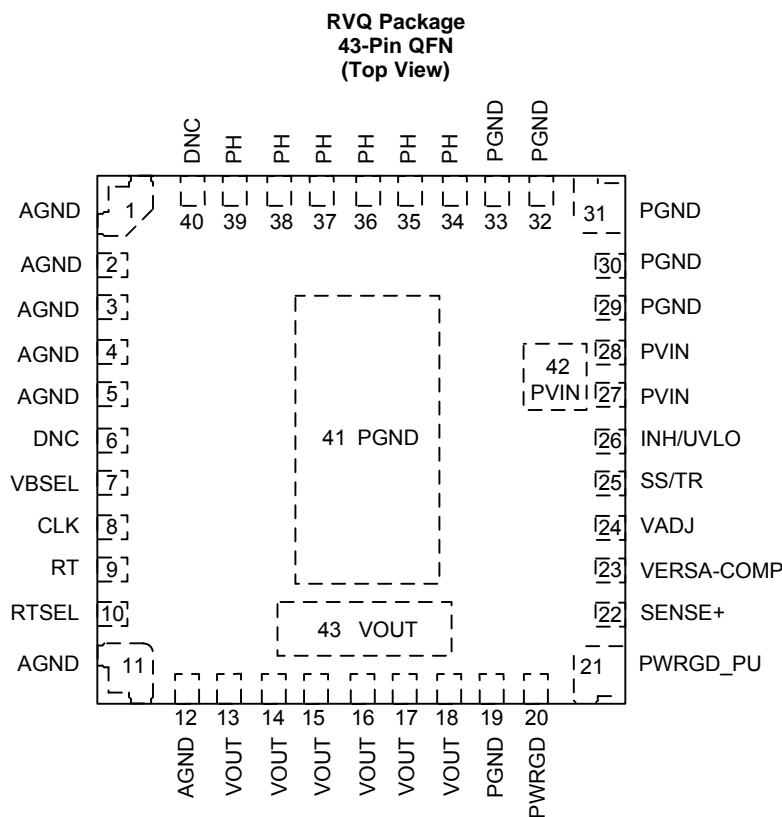

Pin Functions

PIN		TYPE (1)	DESCRIPTION
NAME	NO.		
AGND	1, 2, 3, 4, 5, 11, 12	G	Zero volt reference for the analog control circuitry. All of these pins are not connected together internal to the device and must be connected to one another externally using an analog ground plane on the PCB. Pins 11 and 12 are internally connected to the PGND of the device at a single point. The analog ground plane of the PCB should allow only analog ground currents to flow through these pins.
CLK	8	I	Synchronization input to synchronize the device to an external clock. Connect this pin to AGND if not used.
DNC	6, 40	-	Do Not Connect. Do not connect these pins to AGND, to another DNC pin, or to any other voltage. These pins are connected to internal circuitry. Each pin must be soldered to an isolated pad.
INH/UVLO	26	I	Inhibit and UVLO adjust pin. Use an open drain or open collector device to control the inhibit function. A resistor divider between this pin, AGND, and PVIN adjusts the UVLO voltage. Connect this pin to PVIN if not used.
PGND	19, 29, 30, 31, 32, 33, 41	G	This is the return current path for the power stage of the device. Connect these pins to the input source, the load, and to the bypass capacitors associated with PVIN and VOUT using power ground planes on the PCB. Pad 41 should be connected to the ground planes using multiple vias for good thermal performance.
PH	34, 35, 36, 37, 38, 39	O	Phase switch node. Do not place any external components on these pins or tie them to a pin of another function.
PVIN	27, 28, 42	I	Power input voltage. These pins supply all of the power to the device. Connect these pins to the input source and connect external bypass capacitors between these pins and PGND close to the device.
PWRGD	20	O	Power Good flag pin. This open drain output asserts low if the output voltage is more than approximately $\pm 10\%$ out of regulation. This pin is internally connected to an uncommitted 100k pull-up resistor that can be pulled up to a user-defined voltage applied to the PWRGD_PU pin.

(1) G = Ground, I = Input, O = Output

Pin Functions (continued)

PIN		TYPE ⁽¹⁾	DESCRIPTION
NAME	NO.		
PWRGD_PU	21	I	An internal 100 k pull-up resistor is connected between this pin and the PWRGD pin. If use of this internal pull-up resistor is desired, connect this pin to an appropriate voltage source that is less than or equal to 12 V. If unused, leave this pin floating.
RT	9	I	This pin is connected to internal frequency setting circuitry which sets the default switching frequency to 500 kHz. An external resistor can be connected from this pin to AGND to adjust the switching frequency. Refer to application section in datasheet.
RTSEL	10	I	This pin can be used to adjust the switching frequency to 1 MHz without the need for an external resistor. Connect this pin to AGND to adjust the frequency to 1 MHz. Otherwise, leave this pin floating.
SENSE+	22	I	Remote sense connection. This pin must be connected to VOUT at the load or at the device pins. Connect the pin to VOUT at the load for improved regulation.
SS/TR	25	I	soft-start and tracking pin. Connecting an external capacitor to this pin adjusts the output voltage soft-start ramp above its 4.1 ms default setting. A voltage applied to this pin allows for tracking and sequencing control.
VADJ	24	I	Connecting a resistor between this pin and AGND adjusts the output voltage.
VBSEL	7	I	Selectable internal bias supply. For output voltages ≥ 4.5 V, connect this pin to VOUT. For output voltages < 4.5 V, connect this pin to AGND.
VERSA-COMP	23	I	Connects to internal compensation network. This pin can be left floating or connected to the VADJ pin to select the proper compensation depending on the output voltage.
VOUT	13, 14, 15, 16, 17, 18, 43	O	Output voltage. These pins are connected to the internal output inductor. Connect these pins to the output load and connect external bypass capacitors between these pins and PGND close to the device.

6 Specifications

6.1 Absolute Maximum Ratings

over operating free-air temperature range (unless otherwise noted)⁽¹⁾

		MIN	MAX	UNIT
Input voltage	PVIN, INH/UVLO	–0.3	50	V
	VOUT, SENSE+, VBSEL	–0.3	30 ⁽²⁾	V
	VADJ, VERSA-COMP, RT, RTSEL, SS/TR	–0.3	3.6	V
	PWRGD, PWRGD_PU	–0.3	15	V
	CLK	–0.3	5.5	V
Output voltage	PH	–0.3	50	V
Operating junction temperature ⁽³⁾		–40	125	°C
Storage temperature, T _{stg}		–65	150	°C
Peak Reflow Case Temperature ⁽⁴⁾			245 ⁽⁵⁾	°C
Maximum Number of Reflows Allowed ⁽⁴⁾			3 ⁽⁵⁾	
Mechanical shock	Mil-STD-883D, Method 2002.3, 1 msec, 1/2 sine, mounted		1500	G
Mechanical vibration	Mil-STD-883D, Method 2007.2, 20-2000Hz		20	G

- (1) Stresses beyond those listed under *Absolute Maximum Ratings* may cause permanent damage to the device. These are stress ratings only, which do not imply functional operation of the device at these or any other conditions beyond those indicated under *Recommended Operating Conditions*. Exposure to absolute-maximum-rated conditions for extended periods may affect device reliability.
- (2) The maximum voltage that can be applied to these pins is 30 V or PVIN, whichever is less.
- (3) See temperature derating curves in the Typical Characteristics section for thermal information.
- (4) For soldering specifications, refer to the [Soldering Requirements for BQFN Packages](#) application note.
- (5) Devices with a date code prior to week 14 2018 (1814) have a peak reflow case temperature of 240°C with a maximum of one reflow.

6.2 ESD Ratings

		VALUE	UNIT
V _(ESD)	Electrostatic discharge	Human-body model (HBM), per ANSI/ESDA/JEDEC JS-001 ⁽¹⁾	±1000
		Charged-device model (CDM), per JEDEC specification JESD22-C101 ⁽²⁾	±1000

- (1) JEDEC document JEP155 states that 500-V HBM allows safe manufacturing with a standard ESD control process.
- (2) JEDEC document JEP157 states that 250-V CDM allows safe manufacturing with a standard ESD control process.

6.3 Recommended Operating Conditions

over operating free-air temperature range (unless otherwise noted)

		MIN	NOM	MAX	UNIT
P _{VIN}	Input voltage	4.5		42	V
V _{OUT}	Output voltage	2.5		7.5	V
f _{SW}	Switching frequency	300		1000	kHz
T _A	Operating ambient temperature	–40		105	°C

6.4 Thermal Information

THERMAL METRIC ⁽¹⁾		LMZ34202	UNIT
		RVQ (QFN)	
		43 PINS	
R _{θJA}	Junction-to-ambient thermal resistance	14	°C/W
ψ _{JT}	Junction-to-top characterization parameter	2.6	°C/W
ψ _{JB}	Junction-to-board characterization parameter	9	°C/W

- (1) For more information about traditional and new thermal metrics, see the *Semiconductor and IC Package Thermal Metrics* application report, [SPRA953](#).

6.5 Electrical Characteristics

Over -40°C to $+105^{\circ}\text{C}$ free-air temperature, $\text{PV}_{\text{IN}} = 24\text{ V}$, $\text{V}_{\text{OUT}} = 5\text{ V}$, $\text{I}_{\text{OUT}} = \text{I}_{\text{OUT max}}$, $f_{\text{sw}} = 500\text{ kHz}$,

$\text{C}_{\text{IN}1} = 1 \times 10\text{-}\mu\text{F}$, 100-V 1210 ceramic, $\text{C}_{\text{IN}2} = 1 \times 100\text{-}\mu\text{F}$ 100-V electrolytic bulk, and $\text{C}_{\text{OUT}} = 3 \times 47\text{-}\mu\text{F}$, 16-V 1210 ceramic (unless otherwise noted).

PARAMETER		TEST CONDITIONS	MIN	TYP	MAX	UNIT
INPUT VOLTAGE (PV_{IN})						
PV_{IN}	Input voltage range	Over I_{OUT} range	4.5 ⁽¹⁾		42	V
UVLO	PV_{IN} undervoltage lockout	PV_{IN} increasing		3.2	3.8	V
		PV_{IN} decreasing		2.8		V
OUTPUT VOLTAGE						
$\text{V}_{\text{OUT (ADJ)}}$	Output voltage adjust range	Over I_{OUT} range	2.5		7.5	V
V_{OUT}	Set-point voltage tolerance	$\text{T}_A = 25^{\circ}\text{C}$, $\text{I}_{\text{OUT}} = 200\text{ mA}$		± 0.7	± 1.5 ⁽²⁾	%
	Temperature variation	$-40^{\circ}\text{C} \leq \text{T}_A \leq 105^{\circ}\text{C}$, $\text{I}_{\text{OUT}} = 0\text{ A}$		± 0.9		%
	Line regulation	$\text{T}_A = 25^{\circ}\text{C}$, Over PV_{IN} range, $\text{I}_{\text{OUT}} = 300\text{ mA}$		± 0.1		%
	Load regulation	$\text{T}_A = 25^{\circ}\text{C}$, $\text{I}_{\text{OUT}} = 300\text{ mA}$ to $\text{I}_{\text{OUT max}}$		± 0.3		%
	Total output voltage variation	Includes set-point, line, load, and temperature			± 2	%
$\text{V}_{\text{OUT ripple}}$	Output voltage ripple	20-MHz Bandwidth		10		mV/pp
OUTPUT CURRENT						
I_{OUT}	Output current	$\text{T}_A = 105^{\circ}\text{C}$, natural convection	0		1.5	A
I_{OUT}	Output current	$\text{T}_A = 105^{\circ}\text{C}$, 200LFM	0		2	A
I_{OUT}	Output current	$\text{T}_A = 95^{\circ}\text{C}$, natural convection	0		2	A
I_{LIM}	Overcurrent threshold			2.5		A
PERFORMANCE						
η	Efficiency	$\text{PV}_{\text{IN}} = 12\text{ V}$ $\text{I}_{\text{OUT}} = 1\text{ A}$	$\text{V}_{\text{OUT}} = 7.5\text{ V}$; $f_{\text{SW}} = 400\text{ kHz}$		95	%
			$\text{V}_{\text{OUT}} = 5\text{ V}$; $f_{\text{SW}} = 200\text{ kHz}$		93	%
			$\text{V}_{\text{OUT}} = 5\text{ V}$; $f_{\text{SW}} = 500\text{ kHz}$		92	%
			$\text{V}_{\text{OUT}} = 3.3\text{ V}$; $f_{\text{SW}} = 200\text{ kHz}$		90	%
			$\text{V}_{\text{OUT}} = 2.5\text{ V}$; $f_{\text{SW}} = 200\text{ kHz}$		87	%
		$\text{PV}_{\text{IN}} = 24\text{ V}$ $\text{I}_{\text{OUT}} = 1\text{ A}$	$\text{V}_{\text{OUT}} = 7.5\text{ V}$; $f_{\text{SW}} = 400\text{ kHz}$		92	%
			$\text{V}_{\text{OUT}} = 5\text{ V}$; $f_{\text{SW}} = 250\text{ kHz}$		90	%
			$\text{V}_{\text{OUT}} = 5\text{ V}$; $f_{\text{SW}} = 500\text{ kHz}$		88	%
			$\text{V}_{\text{OUT}} = 3.3\text{ V}$; $f_{\text{SW}} = 250\text{ kHz}$		86	%
			$\text{V}_{\text{OUT}} = 2.5\text{ V}$; $f_{\text{SW}} = 250\text{ kHz}$		81	%
Transient response	$\text{I}_{\text{OUT}} = 50\%$ load step 1 A/ μs slew rate	Recovery time		100		μs
		Over/Undershoot		2		%
SLOW START						
T_{SS}	Internal slow start time	SS/TR pin open		4.1		ms
INHIBIT						
$\text{V}_{\text{INH (high)}}$	Inhibit control	Precision inhibit level	2.00	2.1	2.42	V
$\text{V}_{\text{INH (low)}}$		Inhibit turn-off hysteresis		-0.294		V
I_i (shutdown)	Input shutdown supply current	INH/UVLO pin connected to AGND		2.4	6.2 ⁽³⁾	μA
POWER GOOD (PWRGD)						
V_{PWRGD}	PWRGD thresholds	V_{OUT} rising	Good		95	%
			Fault		110	%
		V_{OUT} falling	Fault		90	%
			Good		105	%

(1) The minimum PV_{IN} is 4.5 V or $(\text{V}_{\text{OUT}} / 0.75)$, whichever is greater. For $\text{V}_{\text{OUT}} = 3.3\text{ V}$, the minimum PV_{IN} is 4.75 V when $\text{I}_{\text{OUT}} > 1.5\text{ A}$.

(2) The stated limit of the set-point voltage tolerance includes the tolerance of both the internal voltage reference and the internal adjustment resistor. The overall output voltage tolerance will be affected by the tolerance of the external R_{SET} resistor.

(3) Guaranteed by design. Not production tested.

Electrical Characteristics (continued)

Over -40°C to $+105^{\circ}\text{C}$ free-air temperature, $PV_{\text{IN}} = 24\text{ V}$, $V_{\text{OUT}} = 5\text{ V}$, $I_{\text{OUT}} = I_{\text{OUT max}}$, $f_{\text{sw}} = 500\text{ kHz}$, $C_{\text{IN}1} = 1 \times 10\text{-}\mu\text{F}$, 100-V 1210 ceramic, $C_{\text{IN}2} = 1 \times 100\text{-}\mu\text{F}$ 100-V electrolytic bulk, and $C_{\text{OUT}} = 3 \times 47\text{-}\mu\text{F}$, 16-V 1210 ceramic (unless otherwise noted).

PARAMETER		TEST CONDITIONS	MIN	TYP	MAX	UNIT
THERMAL SHUTDOWN						
T_{SHUTDOWN}	Thermal shutdown	Shutdown Temperature		160		$^{\circ}\text{C}$
		Hysteresis		10		$^{\circ}\text{C}$
INPUT/OUTPUT CAPACITANCE						
C_{IN}	External input capacitance	ceramic	10 ⁽⁴⁾			μF
		non-ceramic		100		μF
C_{OUT}	External output capacitance	Ceramic	64 ⁽⁵⁾		See ⁽⁶⁾	μF
		Non-ceramic		100	See ⁽⁶⁾	μF
		ceramic + non-ceramic			See ⁽⁶⁾	μF
		Equivalent series resistance (ESR)			20	$\text{m}\Omega$

- (4) The specified minimum ceramic input capacitance represents the standard capacitance value. The actual effective capacitance after considering the effects of DC bias and temperature variation should be $\geq 4.7\ \mu\text{F}$.
- (5) The amount of required output capacitance varies depending on the output voltage (see [Output Capacitor Selection](#)). The minimum required output capacitance must be comprised of ceramic capacitance. The amount of required ceramic capacitance represents the standard capacitance value. Locate the capacitance close to the device. Adding additional ceramic or non-ceramic capacitance close to the load improves the response of the regulator to load transients.
- (6) The maximum allowable output capacitance varies depending on the output voltage (see [Output Capacitor Selection](#)).

6.6 Switching Characteristics

over operating free-air temperature range (unless otherwise noted)

PARAMETER		TEST CONDITIONS	MIN	TYP	MAX	UNIT
f_{sw}	Switching frequency	RT and RTSEL pins open	410	500	590	kHz
f_{CLK}	CLK Control	Synchronization frequency	200		1000	kHz
$V_{\text{CLK-H}}$		CLK high level	2		5.5	V
$V_{\text{CLK-L}}$		CLK low level			0.4	V
D_{CLK}		CLK duty cycle	10%	50%	90%	

6.7 Typical Characteristics

T_A = 25°C, unless otherwise noted.



图 1. Efficiency vs Output Current



图 2. Efficiency vs Output Current

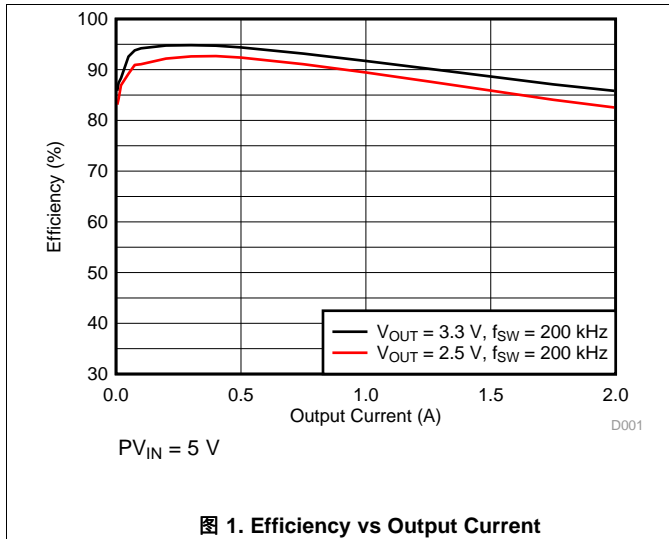

图 3. Power Dissipation vs Output Current

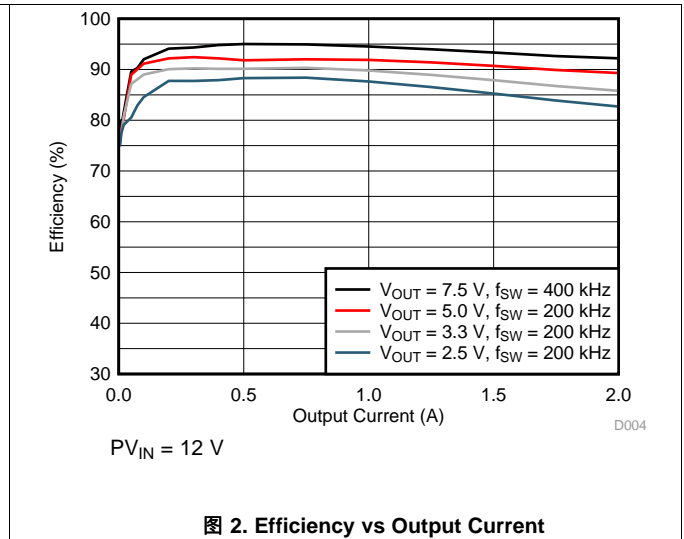

图 4. Power Dissipation vs Output Current

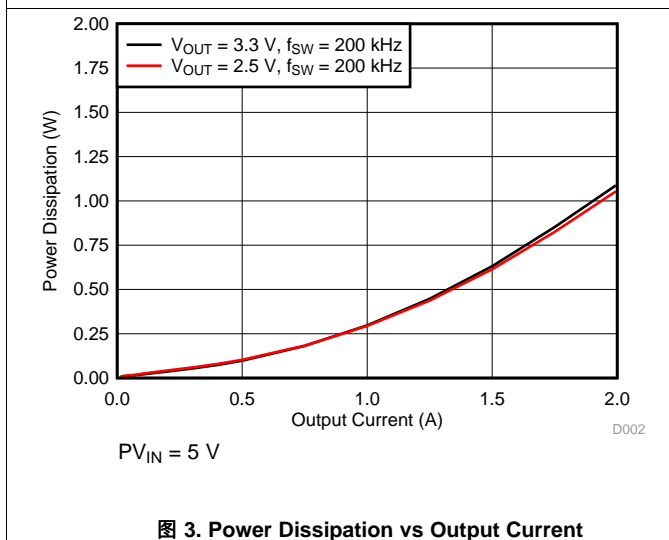

图 5. Voltage Ripple vs Output Current

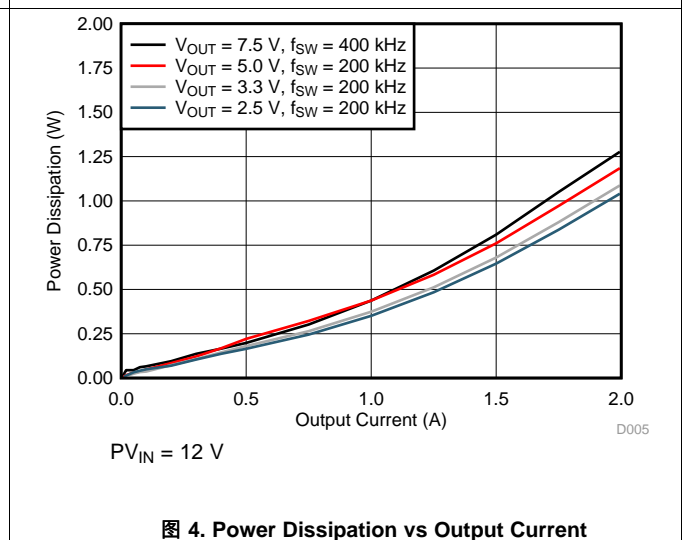

图 6. Voltage Ripple vs Output Current

Typical Characteristics (接下页)

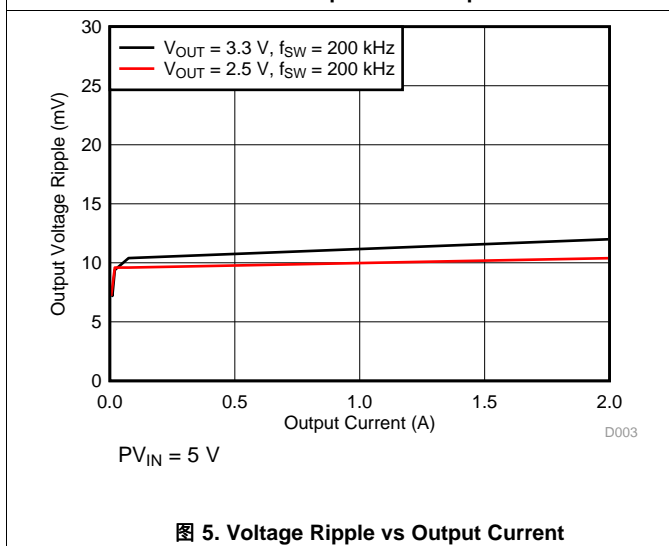
$T_A = 25^\circ\text{C}$, unless otherwise noted.

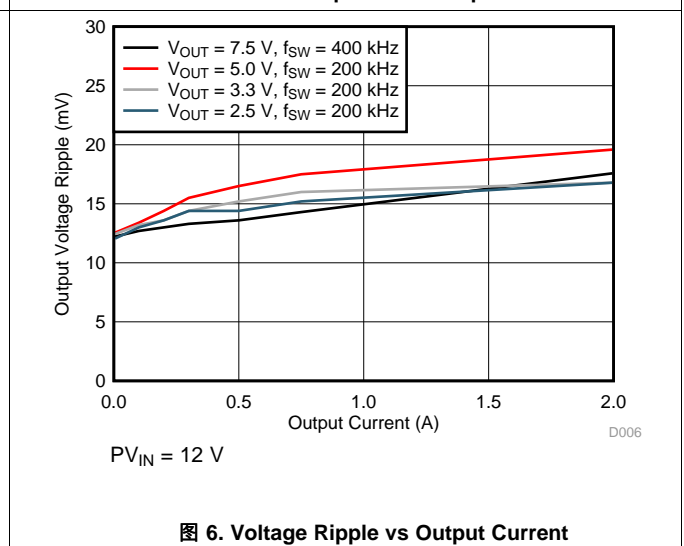
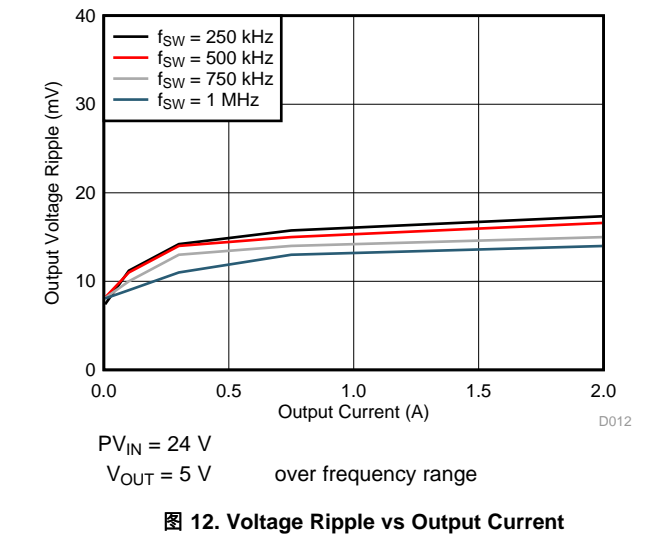
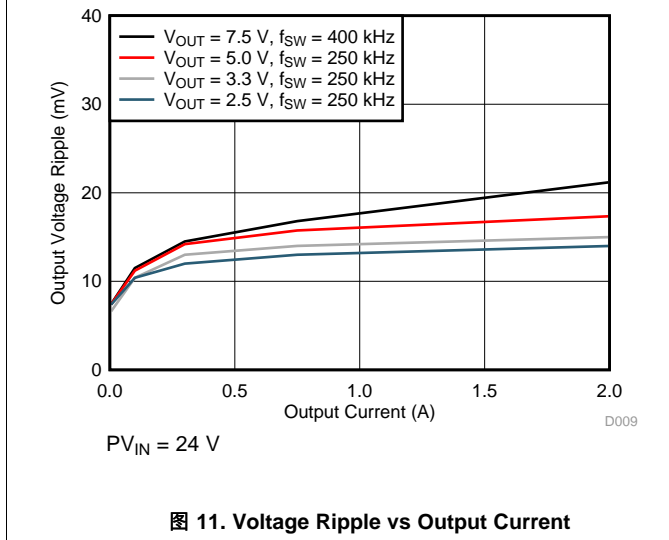
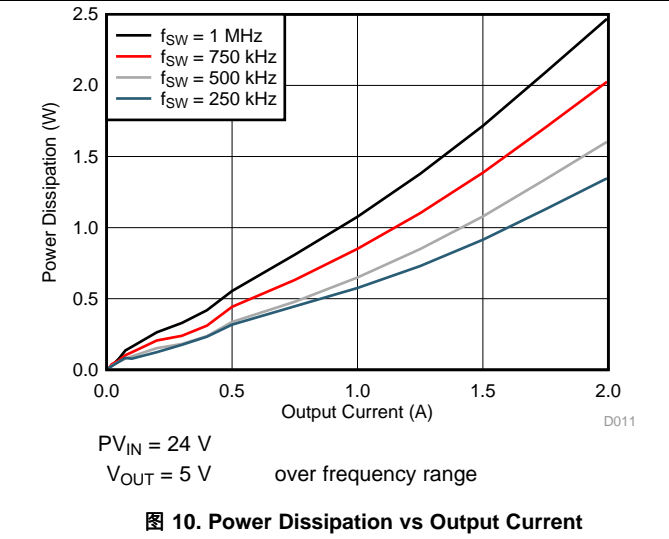
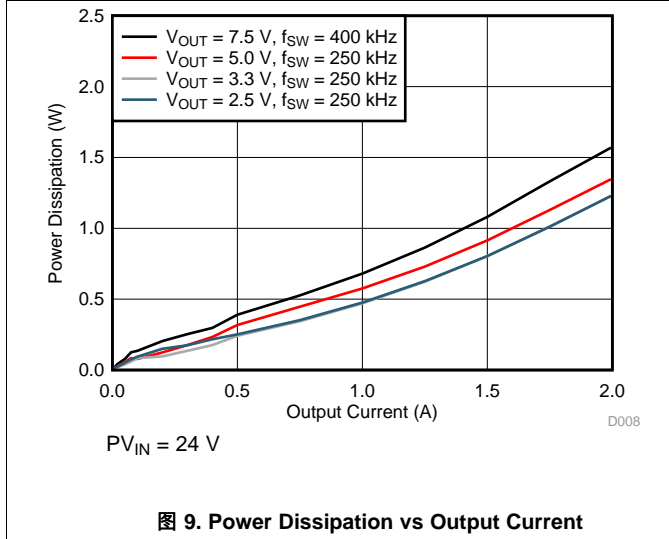
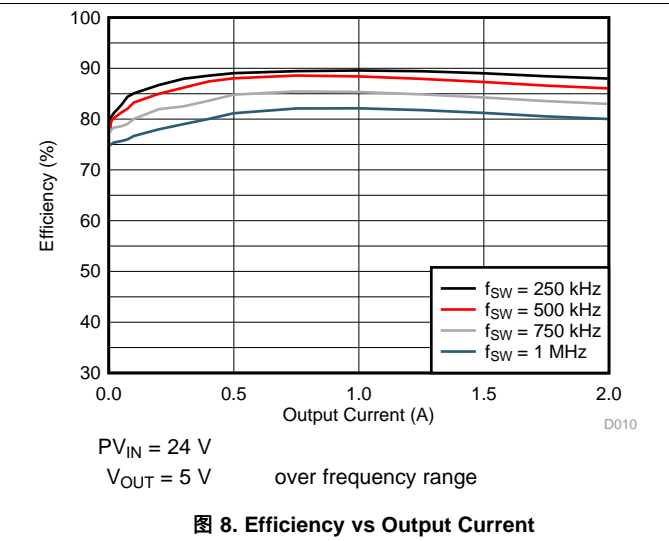
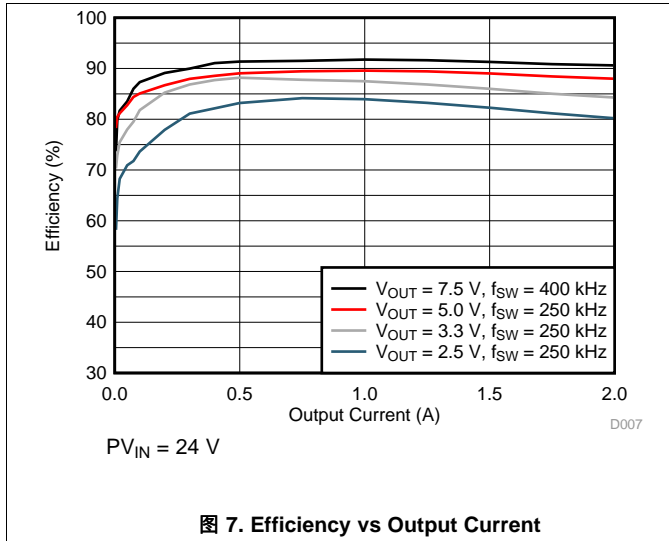

Typical Characteristics (接下页)

$T_A = 25^\circ\text{C}$, unless otherwise noted.

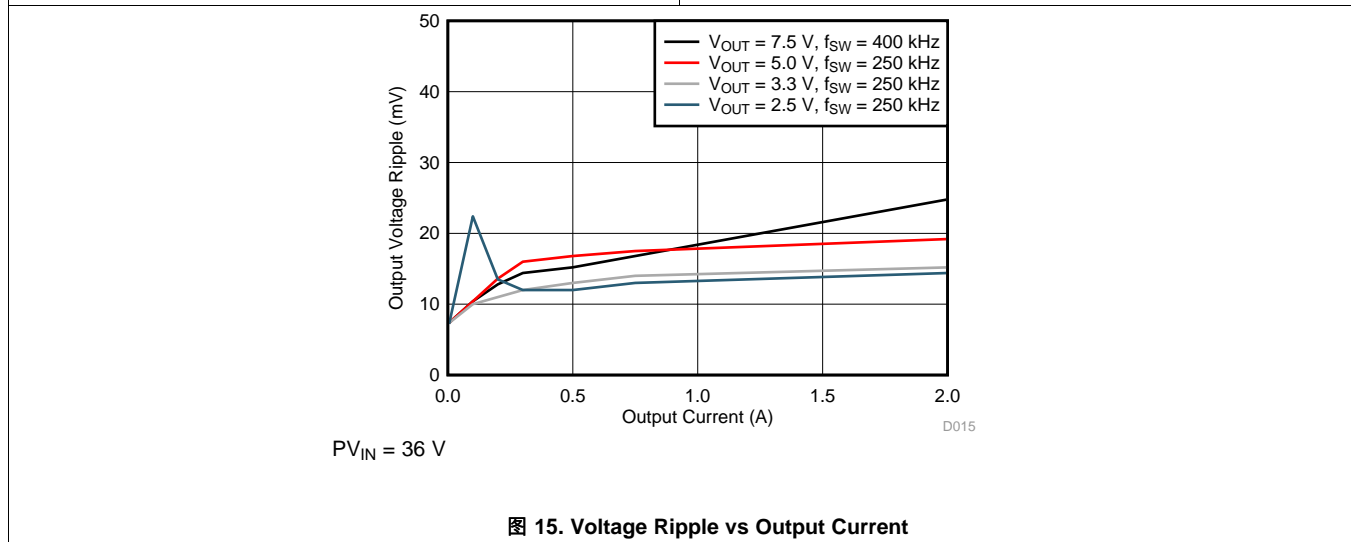
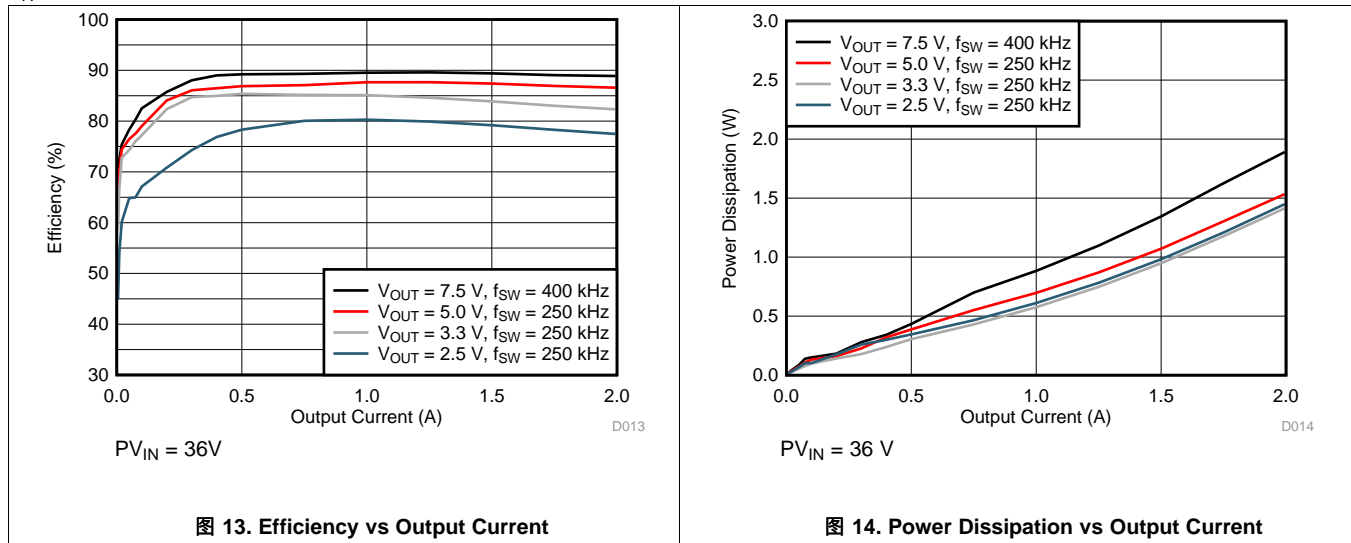

6.8 Typical Characteristics (Thermal Derating)

The temperature derating curves represent the conditions at which internal components are at or below the manufacturer's maximum operating temperatures. Derating limits apply to devices soldered directly to a 50 mm x 100 mm, 4-layer PCB with 2 oz. copper.



图 16. Safe Operating Area



图 17. Safe Operating Area

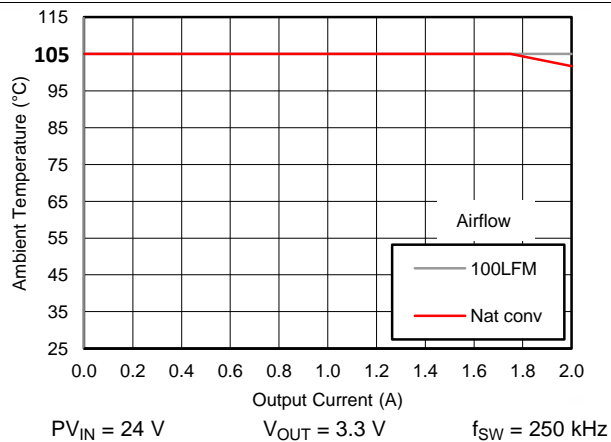

图 18. Safe Operating Area

7 Detailed Description

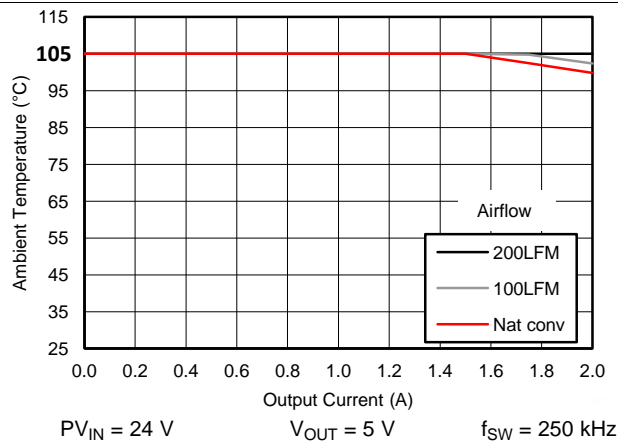
7.1 Overview

The LMZ34202 is a full featured 42-V input, 2-A, synchronous step down converter with PWM, MOSFETs, inductor, and control circuitry integrated into a low-profile, overmolded package. This device enables small designs by integrating all but the input and output capacitors, while still leaving the ability to adjust key parameters to meet specific design requirements. The LMZ34202 provides a 3x output voltage range of 2.5 V to 7.5 V. A single external resistor is used to adjust the output voltage to the desired output. The switching frequency is also adjustable by using an external resistor or a synchronization pulse to accommodate various input and output voltage conditions and to optimize efficiency. The device provides accurate voltage regulation for a variety of loads by using an internal voltage reference that is 2% accurate over temperature. Input under-voltage lockout is internally set at 3.2 V, but can be adjusted upward using a resistor divider on the INH/UVLO pin of the device. The INH/UVLO pin can also be pulled low to put the device in standby mode to reduce input quiescent current. The device provides a power good signal to indicate when the output is within $\pm 5\%$ of its nominal voltage. Thermal shutdown and current limit features protect the device during an overload condition. Automatic PFM mode improves light-load efficiency. A 43-pin, QFN, package that includes exposed bottom pads provides a thermally enhanced solution for space-constrained applications.

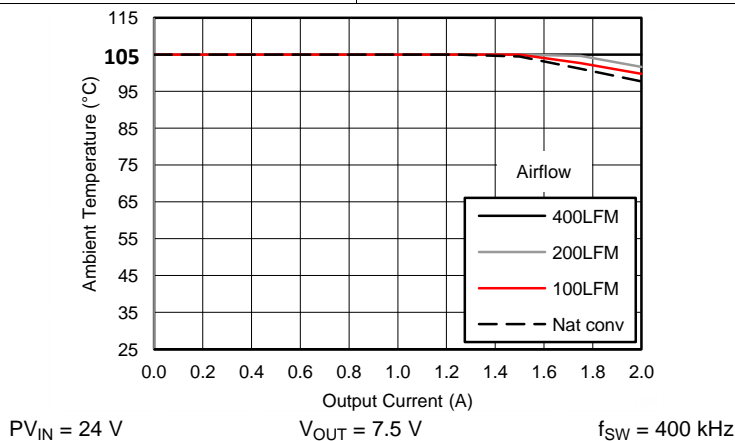
7.2 Functional Block Diagram

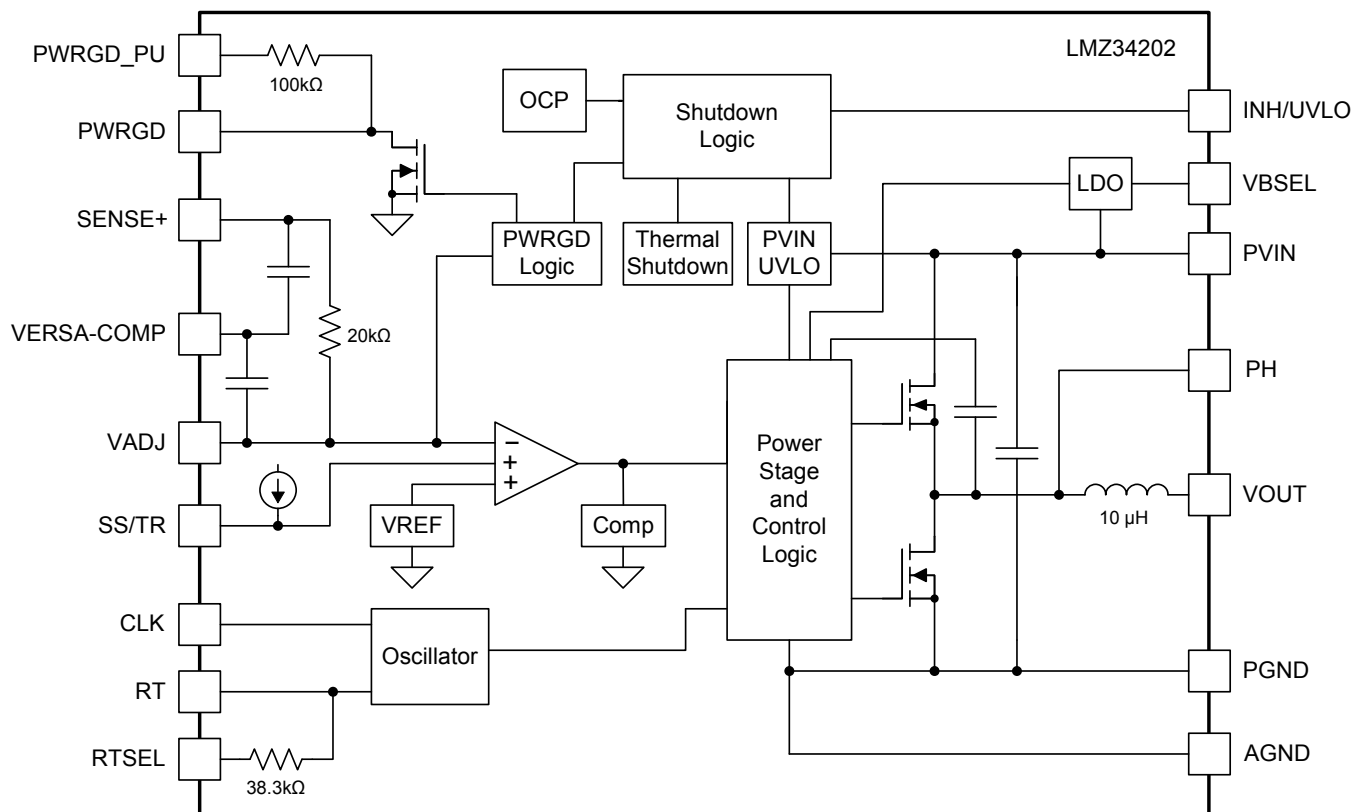

7.3 Feature Description

7.3.1 Adjusting the Output Voltage

The VADJ pin sets the output voltage of the LMZ34202. The output voltage adjustment range is from 2.5 V to 7.5 V. The switching frequency range for any output voltage must be determined from 表 4 or 表 5. The adjustment method requires the addition of R_{SET} , which sets the output voltage, and the connection of SENSE+ to VOUT. The R_{SET} resistor must be connected directly between the VADJ (pin 24) and AGND. The SENSE+ pin (pin 22) must be connected to VOUT either at the load for improved regulation or at VOUT of the device. 表 1 lists the standard external R_{SET} resistor for a number of common bus voltages.

表 1. Standard R_{SET} Resistor Values for Common Output Voltages

R_{SET} (k Ω)	OUTPUT VOLTAGE V_{OUT} (V)				
	2.5	3.3	5.0	6.0	7.5
	13.7	8.87	5.11	4.02	3.09

For other output voltages, the value of the required resistor can either be calculated using the following formula, or simply selected from the range of values given in 表 2.

$$R_{SET} = \frac{20}{\left[\left(\frac{V_{OUT}}{1.011}\right) - 1\right]} \text{ (k}\Omega\text{)} \quad (1)$$

表 2. Standard R_{SET} Resistor Values

V_{OUT} (V)	R_{SET} (k Ω)	V_{OUT} (V)	R_{SET} (k Ω)
2.5	13.7	5.1	4.99
2.6	12.7	5.2	4.87
2.7	11.8	5.3	4.75
2.8	11.3	5.4	4.64
2.9	10.7	5.5	4.53
3.0	10.2	5.6	4.42
3.1	9.76	5.7	4.32
3.2	9.31	5.8	4.22
3.3	8.87	5.9	4.12
3.4	8.45	6.0	4.02
3.5	8.06	6.1	3.97
3.6	7.87	6.2	3.92
3.7	7.50	6.3	3.83
3.8	7.32	6.4	3.74
3.9	6.98	6.5	3.65
4.0	6.81	6.6	3.61
4.1	6.49	6.7	3.57
4.2	6.34	6.8	3.48
4.3	6.19	6.9	3.40
4.4	5.90	7.0	3.36
4.5	5.76	7.1	3.32
4.6	5.62	7.2	3.24
4.7	5.49	7.3	3.20
4.8	5.36	7.4	3.16
4.9	5.23	7.5	3.09
5.0	5.11		

7.3.2 Switching Frequency (RT)

The switching frequency range of the LMZ34202 is 200 kHz to 1 MHz. Not all PV_{IN} , V_{OUT} , and I_{OUT} conditions can be set to all of the frequencies in this range. See [Recommended Operating Range](#) for the allowable operating ranges. The switching frequency can easily be set one of three ways. First, leaving the RT pin (pin 9) and RTSEL pin (pin 10) floating (OPEN) allows operation at the default switching frequency of 500 kHz. Also, connecting the RTSEL pin to AGND while floating the RT pin, sets the switching frequency to 1 MHz. The option is also available to set the switching frequency to any frequency in the range of 200 kHz to 1 MHz, by connecting a resistor (R_{RT}) between the RT pin and AGND, while floating the RTSEL pin. See [表 3](#) for standard resistor values for setting the switching frequency or use [公式 2](#) to calculate R_{RT} for other switching frequencies.

表 3. Switching Frequency R_{RT} Values

Switching Frequency	R_{RT} (k Ω)
250 kHz	158
500 kHz	78.7 or (RT pin OPEN, RTSEL pin OPEN)
750 kHz	53.6
1 MHz	38.3 or (RT pin OPEN, RTSEL pin to AGND)

$$R_{RT} = \frac{40200}{F_{sw}(kHz)} - 0.6 \text{ (k}\Omega\text{)} \quad (2)$$

7.3.3 Recommended Operating Range

[表 4](#) and [表 5](#) below show the allowable switching frequencies for a given range of output voltages. Reference [表 4](#) for applications where the maximum output current is 1.75 A or less. Reference [表 5](#) for applications that the output current is greater than 1.75 A. Notice that applications requiring less than 1.75 A can operate over a much wider range of switching frequencies. For the most efficient solution, always operate at the lowest allowable frequency.

**表 4. Switching Frequency vs Output Voltage
Output Current ≤ 1.75 A**

V_{OUT} RANGE (V)	SWITCHING FREQUENCY RANGE (kHz)					
	$PV_{IN} = 12$ V		$PV_{IN} = 24$ V		$PV_{IN} = 36$ V	
	MIN	MAX	MIN	MAX	MIN	MAX
2.5 - 3.5 V	200	1000	200	600	200	400
>3.5 - 4.5 V	200	1000	200	850	200	550
>4.5 - 5.5 V	200	1000	200	1000	200	750
>5.5 - 6.5 V	300	1000	200	1000	200	1000
>6.5 - 7.5 V	300	900	300	1000	300	950

**表 5. Switching Frequency vs Output Voltage
Output Current > 1.75 A**

V_{OUT} RANGE (V)	SWITCHING FREQUENCY RANGE (kHz)					
	$PV_{IN} = 12$ V		$PV_{IN} = 24$ V		$PV_{IN} = 36$ V	
	MIN	MAX	MIN	MAX	MIN	MAX
2.5 - 3.5 V	200	450	200	500	200	400
>3.5 - 4.5 V	200	500	200	600	200	550
>4.5 - 5.5 V	200	500	200	650	200	700
>5.5 - 6.5 V	300	500	250	700	250	800
>6.5 - 7.5 V	300	400	300	750	300	800

7.3.4 Synchronization (CLK)

The LMZ34202 switching frequency can also be synchronized to an external clock from 200 kHz to 1 MHz. Not all V_{IN} , V_{OUT} , and I_{OUT} conditions can be set to all of the frequencies in this range. See [Recommended Operating Range](#) for the allowable operating ranges.

To implement the synchronization feature, connect a clock signal to the CLK pin with a duty cycle between 10% and 90%. The clock signal amplitude must transition lower than 0.4 V and higher than 2.0 V. The start of the switching cycle is synchronized to the rising edge of CLK pin. Before the external clock is present the device operates in RT mode and the switching frequency is set by R_{RT} resistor. Select R_{RT} to set the frequency close to the external synchronization frequency. When the external clock is present, the CLK mode overrides the RT mode. If the external clock is removed or fails at logic high or low, the LMZ34202 will switch at the frequency programmed by the R_{RT} resistor after a time-out period. Connect the CLK pin (pin 8) to AGND if not used.

7.3.5 Output Capacitor Selection

The minimum required and maximum output capacitance of the LMZ34202 is a function of the output voltage as shown in [表 6](#). Additionally, the output voltage will determine the Versa-Comp configuration (see [VERSA-COMP Pin Configurations](#)), which is also included in [表 6](#). The capacitance values listed in [表 6](#) are the specified capacitance values. The effects of DC bias and temperature variation must be considered when using ceramic capacitance. For ceramic capacitors, package size, voltage rating, and dielectric material will contribute to differences between the specified value and the actual effective value of the capacitance. $C_{OUT(min)}$ must be comprised of ceramic type capacitors. Additional capacitance, not exceeding $C_{OUT(max)}$, may be ceramic type or low-ESR polymer type. See [表 7](#) for a preferred list of output capacitors by vendor.

表 6. Required Output Capacitance

V_{OUT} (V)	MINIMUM REQUIRED C_{OUT} (μ F) ⁽¹⁾ ⁽²⁾	MAXIMUM C_{OUT} (μ F) ⁽²⁾	Versa-Comp Connection
2.5	64	350	Leave OPEN
3.3	64	350	Connect to VADJ
5.0	64	350	Connect to VADJ
6.0	64	200	Connect to VADJ
7.5	100	200	Connect to VADJ

- (1) Minimum required output capacitance must be comprised of ceramic capacitance.
(2) C_{OUT} values represent specified capacitance values.

表 7. Recommended Output Capacitors⁽¹⁾

VENDOR	SERIES	PART NUMBER	CAPACITOR CHARACTERISTICS		
			WORKING VOLTAGE (V)	CAPACITANCE ⁽²⁾ (μ F)	ESR ⁽³⁾ (m Ω)
TDK	X5R	C3225X5R1C106K	16	10	2
Murata	X5R	GRM32ER61C106K	16	10	2
TDK	X5R	C3225X5R1C226M	16	22	2
Murata	X5R	GRM32ER61C226K	16	22	2
TDK	X5R	C3225X5R1A476M	10	47	2
Murata	X5R	GRM32ER61C476K	16	47	3
TDK	X5R	C3225X5R0J107M	6.3	100	2
Murata	X5R	GRM32ER60J107M	6.3	100	2
Murata	X5R	GRM32ER61A107M	10	100	2
Kemet	X5R	C1210C107M4PAC7800	16	100	2
Panasonic	POSCAP	6TPE100MI	6.3	100	18
Panasonic	POSCAP	6TPF220M9L	6.3	220	9
Panasonic	POSCAP	6TPE220ML	6.3	220	12

- (1) **Capacitor Supplier Verification, RoHS, Lead-free and Material Details**
Consult capacitor suppliers regarding availability, material composition, RoHS and lead-free status, and manufacturing process requirements for any capacitors identified in this table.
(2) Specified capacitance values.
(3) Maximum ESR @ 100kHz, 25°C.

7.3.6 VERSA-COMP Pin Configurations

The versa-comp feature of the LMZ34202 allows a simple method to adjust the internal compensation network to provide the optimized phase and gain margin based on the output voltage. This easy-to-use feature requires no external components and is implemented by the simple configuration of two adjacent pins on the module.

The versa-comp feature must be configured in one of two ways; VERSA-COMP pin left OPEN or VERSA-COMP pin tied to VADJ. The output voltage determines the appropriate Versa-Comp pin configuration. 表 8 lists the Versa-Comp configuration. 图 19 shows the two possible Versa-Comp pin configurations.



图 19. Versa-Comp Configurations

表 8. VERSA-COMP Pin Configurations

V _{OUT} RANGE (V)		VERSA-COMP PIN CONFIGURATION
MIN	MAX	
2.5	< 3.0	OPEN
3.0	7.5	Connect to VADJ

7.3.7 Input Capacitor Selection

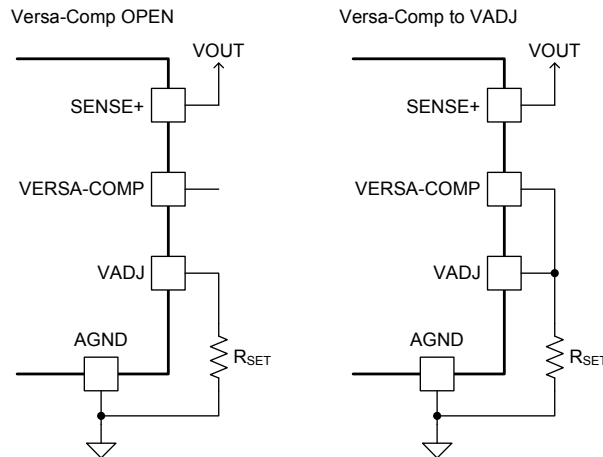
The LMZ34202 requires a ceramic capacitor with a minimum effective input capacitance of 4.7 μF . Use only high-quality ceramic type X5R or X7R capacitors with sufficient voltage rating. An additional 100 μF of non-ceramic capacitance is recommended for applications with transient load requirements. The voltage rating of input capacitors must be greater than the maximum input voltage. To compensate the derating of ceramic capacitors, a voltage rating of twice the maximum input voltage is recommended. At worst case, when operating at 50% duty cycle and maximum load, the combined ripple current rating of the input capacitors must be at least 1.0 Arms. 表 9 includes a preferred list of capacitors by vendor.

表 9. Recommended Input Capacitors⁽¹⁾

VENDOR	SERIES	PART NUMBER	CAPACITOR CHARACTERISTICS		
			WORKING VOLTAGE (V)	CAPACITANCE ⁽²⁾ (μF)	ESR ⁽³⁾ (m Ω)
TDK	X5R	C3225X5R1H106K	50	10	3
Murata	X7R	GRM32ER71H106K	50	10	2
Murata	X7R	GRM32ER71J106K	63	10	2
Panasonic	ZA	EEHZA1H101P	50	100	28
Panasonic	ZA	EEHZA1J560P	63	56	30

(1) **Capacitor Supplier Verification, RoHS, Lead-free and Material Details**

Consult capacitor suppliers regarding availability, material composition, RoHS and lead-free status, and manufacturing process requirements for any capacitors identified in this table.

(2) Specified capacitance values

(3) Maximum ESR @ 100kHz, 25°C.

7.3.8 Output On/Off Inhibit (INH/UVLO)

The INH/UVLO pin provides on and off control of the device. The INH input provides a precise 2.1 V rising threshold to allow direct logic drive or connection to a voltage divider from a higher voltage source such as PV_{IN} . Once the INH/UVLO pin voltage exceeds the threshold voltage, the device starts operation. The INH input also incorporates 300 mV (typ) of hysteresis resulting in a falling threshold of 1.8 V. If the INH/UVLO pin voltage is pulled below the threshold voltage, the regulator stops switching and enters low quiescent current state. The INH/UVLO pin cannot be open circuit or floating. The simplest way to enable the operation of the LMZ34202 is to connect the INH/UVLO pin to PV_{IN} pin directly as shown in [图 20](#). This connection allows the LMZ34202 device to restart when PV_{IN} is again within the operation range.

If an application requires controlling the INH/UVLO pin, either drive it directly with a logic input or use an open drain and collector device to interface with the pin and place a 100-k Ω resistor between this pin and PV_{IN} pin as shown in [图 21](#). When turning Q1 on applies a low voltage to the inhibit control (INH/UVLO) pin and disables the output of the supply, shown in [图 22](#). If Q1 is turned off, the supply executes a soft-start power-up sequence, as shown in [图 23](#).



图 20. Enabling the Device



图 21. Typical Inhibit Control

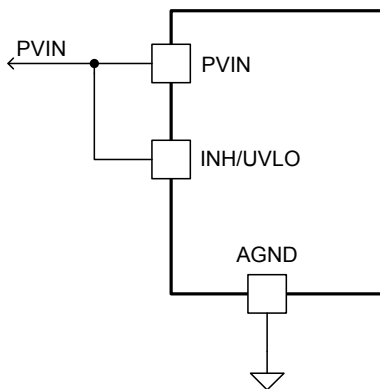

图 22. Inhibit Turn-Off

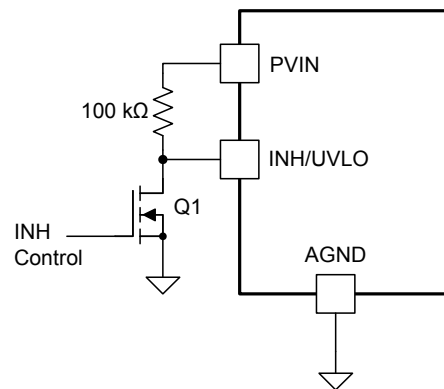

图 23. Inhibit Turn-On

7.3.9 Under Voltage Lockout (UVLO)

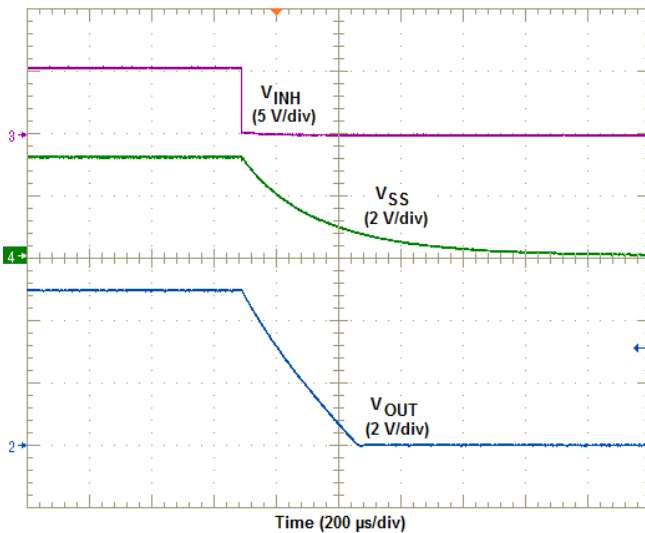
The LMZ34202 device has an internal UVLO circuit which prevents the device from operating until the PV_{IN} voltage exceeds the UVLO threshold, (3.2 V (typ)). The device will begin switching and the output voltage will begin to rise once PV_{IN} exceeds the threshold, however PV_{IN} must be greater than $(V_{OUT}/0.75)$ in order to for V_{OUT} to regulate at the set-point voltage.

Applications may require a higher UVLO threshold to prevent early turn-on, for sequencing requirements, or to prevent input current draw at lower input voltages. An external resistor divider can be added to the INH/UVLO pin to adjust the UVLO threshold higher. The external resistor divider can be configured as shown in 图 24. 表 10 lists standard values for R_{UVLO1} and R_{UVLO2} to adjust the UVLO voltage higher.

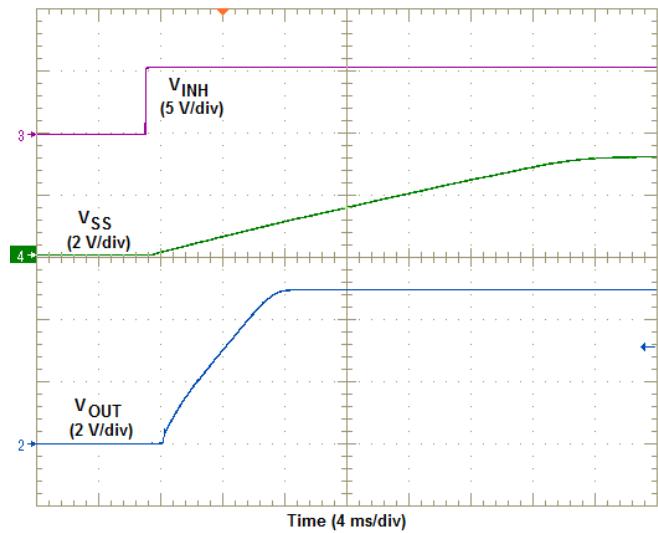

图 24. Adjustable PVIN UVLO

表 10. Resistor Values for Adjusting PVIN UVLO

PVIN UVLO (V)	4.5	10	15	20	25	30
R_{UVLO1} (k Ω)	100	100	100	100	100	100
R_{UVLO2} (k Ω)	46.4	21.0	14.0	10.5	8.45	6.98

7.3.10 Remote Sense

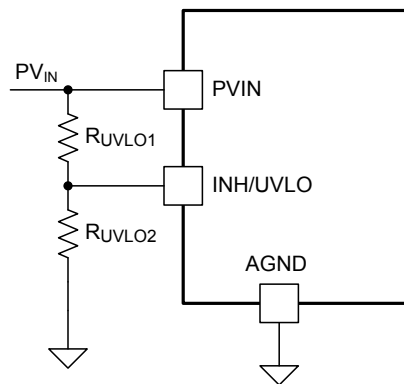
The SENSE+ pin must be connected to V_{OUT} at the load, or at the device pins.

Connecting the SENSE+ pin to V_{OUT} at the load improves the load regulation performance of the device by allowing it to compensate for any I-R voltage drop between its output pins and the load. An I-R drop is caused by the high output current flowing through the small amount of pin and trace resistance. This should be limited to a maximum of 300 mV.

注

The remote sense feature is not designed to compensate for the forward drop of nonlinear or frequency dependent components that may be placed in series with the converter output. Examples include OR-ing diodes, filter inductors, ferrite beads, and fuses. When these components are enclosed by the SENSE+ connection, they are effectively placed inside the regulation control loop, which can adversely affect the stability of the regulator.

7.3.11 VBSEL

The VBSEL pin allows the user to select the input source of the internal bias circuitry to improve efficiency. For output voltages ≥ 4.5 V, connect this pin to V_{OUT} . For output voltages < 4.5 V, connect this pin to AGND.

7.3.12 Soft-Start (SS/TR)

Leaving SS/TR pin open enables the internal slow start time interval of approximately 4.1 ms. Adding additional capacitance between the SS pin and AGND increases the slow start time. Increasing the slow start time will reduce inrush current seen by the input source and reduce the current seen by the device when charging the output capacitors. To avoid the activation of current limit and ensure proper start-up, the SS capacitor may need to be increased when operating near the maximum output capacitance limit.

See 表 11 below for SS capacitor values and timing interval.

表 11. Soft-Start Capacitor Values and Soft-Start Time

C _{SS} (nF)	open	15	22	33	47
SS Time (ms)	4.1	7	10	15	20

7.3.13 Power Good (PWRGD) and Pull-up (PWRGD_PU)

The PWRGD pin is an open drain output. Once the voltage on the SENSE+ pin is between 95% and 105% of the set voltage, the PWRGD pin pull-down is released and the pin floats. The recommended pullup resistor value is between 10 kΩ and 100-kΩ to a voltage source that is 12 V or less. The LMZ34202 has an internal 100-kΩ between the PWRGD pin (pin 20) and the PWRGD_PU pin (pin 21). Connect the PWRGD_PU pin to an external voltage source to avoid using an external pullup resistor. The PWRGD pin is pulled low when the voltage on SENSE+ is lower than 90% or greater than 110% of the nominal set voltage.

7.3.14 Overcurrent Protection

For protection against load faults, the LMZ34202 incorporates output overcurrent protection. Applying a load that exceeds the regulator's overcurrent threshold causes the output to shut down when the output voltage falls below the PWRGD threshold. Following shutdown, the module periodically attempts to recover by initiating a soft-start power-up as shown in 图 25. This is described as a hiccup mode of operation, whereby the module continues in a cycle of successive shutdown and power up until the load fault is removed. During this period, the average current flowing into the fault is significantly reduced which reduces power dissipation. Once the fault is removed, the module automatically recovers and returns to normal operation as shown in 图 26.

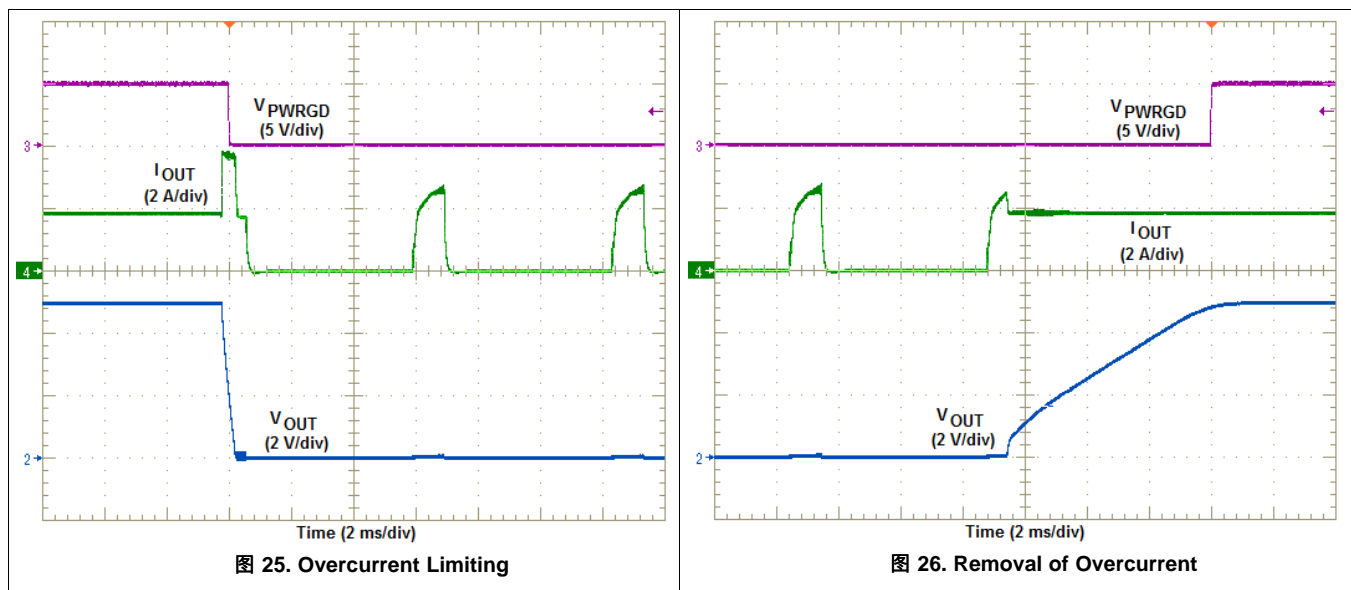

7.3.15 Thermal Shutdown

The internal thermal shutdown circuitry forces the device to stop switching if the junction temperature exceeds 160°C typically. The device reinitiates the power up sequence when the junction temperature drops below 150°C typically.

7.4 Device Functional Modes

7.4.1 Active Mode

The LMZ34202 is in Active Mode when PVIN is above the UVLO threshold and the INH/UVLO pin voltage is above the INH high threshold. The simplest way to enable the LMZ34202 is to connect the INH/UVLO terminal to PVIN. This allows self start-up of the LMZ34202 when the input voltage is in the operation range: 4.5 V to 42 V.

7.4.2 Light Load Operation

At light load, the LMZ34202 operates in pulse skip mode to improve efficiency and decrease power dissipation by reducing switching losses and gate drive losses. In light load operation (PFM mode), the output voltage can rise slightly above the set-point specification. To avoid this behavior, a 300-mA load is required on the output.

7.4.3 Shutdown Mode

The INH/UVLO pin provides electrical ON and OFF control for the LMZ34202. When the INH/UVLO pin voltage is below the INH threshold, the device is in shutdown mode. In shutdown mode the stand-by current is 2.4 μ A typically with $PV_{IN} = 24$ V. The LMZ34202 also employs under voltage lock out protection. If PV_{IN} is below the UVLO level, the output of the regulator turns off.

8 Application and Implementation

注

Information in the following applications sections is not part of the TI component specification, and TI does not warrant its accuracy or completeness. TI's customers are responsible for determining suitability of components for their purposes. Customers should validate and test their design implementation to confirm system functionality.

8.1 Application Information

The LMZ34202 is a synchronous step down DC-DC power module. It is used to convert a higher DC voltage to a lower DC voltage with a maximum output current of 2 A. The following design procedure can be used to select components for the LMZ34202. Alternately, the WEBENCH® software may be used to generate complete designs. When generating a design, the WEBENCH software utilizes an iterative design procedure and accesses comprehensive databases of components.

8.2 Typical Application

8.2.1 Minimum External Component Application

The LMZ34202 requires only a few external components to convert from a wide input voltage supply range to a wide range of output voltages. 图 27 shows a basic LMZ34202 schematic with only the minimum required components.



图 27. LMZ34202 Minimum External Component Application

8.2.1.1 Design Requirements

For this design example, use the parameters listed in 表 12 and follow the design procedures below.

表 12. Design Example Parameters

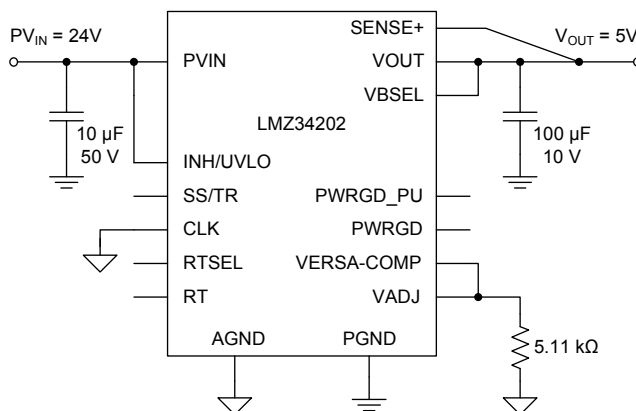
DESIGN PARAMETER	VALUE
Input Voltage PV_{IN}	24 V typical
Output Voltage V_{OUT}	5.0 V
Output Current Rating	2 A
Operating Frequency	500 kHz

8.2.1.2 Detailed Design Procedure

8.2.1.2.1 Custom Design With WEBENCH® Tools

[Click here](#) to create a custom design using the LMZ34202 device with the WEBENCH® Power Designer.

1. Start by entering the input voltage (V_{IN}), output voltage (V_{OUT}), and output current (I_{OUT}) requirements.
2. Optimize the design for key parameters such as efficiency, footprint, and cost using the optimizer dial.
3. Compare the generated design with other possible solutions from Texas Instruments.

The WEBENCH Power Designer provides a customized schematic along with a list of materials with real-time pricing and component availability.

In most cases, these actions are available:

- Run electrical simulations to see important waveforms and circuit performance
- Run thermal simulations to understand board thermal performance
- Export customized schematic and layout into popular CAD formats
- Print PDF reports for the design, and share the design with colleagues

Get more information about WEBENCH tools at www.ti.com/WEBENCH.

8.2.1.2.2 Output Voltage Set-Point

The output voltage of the LMZ34202 device is externally adjustable using a single resistor (R_{SET}). Select the value of R_{SET} from [表 2](#) or calculate using [公式 3](#):

$$R_{SET} = \frac{20}{\left[\left(\frac{V_{OUT}}{1.011} \right) - 1 \right]} \quad (\text{k}\Omega) \quad (3)$$

Knowing the desired output voltage is 5 V, the R_{SET} value can then be calculated using [公式 3](#) or selected from [表 2](#). The formula yields a value of 5.07 k Ω . Choose the closest available value of 5.11 k Ω for R_{SET} .

8.2.1.2.3 RT and RTSEL

The default switching frequency of the LMZ34202 is set to 500 kHz by leaving the RT pin open and the RTSEL pin open. The switching frequency of this application is 500-kHz, therefore no additional resistor is required to set the switching frequency. If another frequency is desired, use [表 3](#) to select the required resistor value.

8.2.1.2.4 VERSA-COMP

The Versa-Comp feature of the LMZ34202 configures the internal compensation based on the output voltage. From [表 8](#), the required Versa-Comp configuration for a 5-V output is to connect the VERSA-COMP pin to the VADJ pin.

8.2.1.2.5 VBSEL

The VBSEL pin allows the user to select the input source of the internal bias circuitry to improve efficiency. For output voltages ≥ 4.5 V, connect this pin to VOUT. For output voltages < 4.5 V, connect this pin to AGND.

8.2.1.2.6 Input Capacitors

For this design, a 10- μ F, X7R dielectric ceramic capacitor rated for 50 V is used for the input decoupling capacitor. The effective capacitance at 24 V is 5.7 μ F, the equivalent series resistance (ESR) is approximately 3 m Ω , and the current-rating is 5 A.

8.2.1.2.7 Output Capacitors

The minimum required output capacitance for a 5 V output is 64 μ F of ceramic capacitance. For this design, a 100 μ F, X5R dielectric ceramic capacitor rated for 10 V is used for the output capacitor.

8.2.1.3 Application Curves



图 28. Start-up Waveforms



图 29. Output Ripple and PH Node Waveforms

8.2.2 INH Control Application

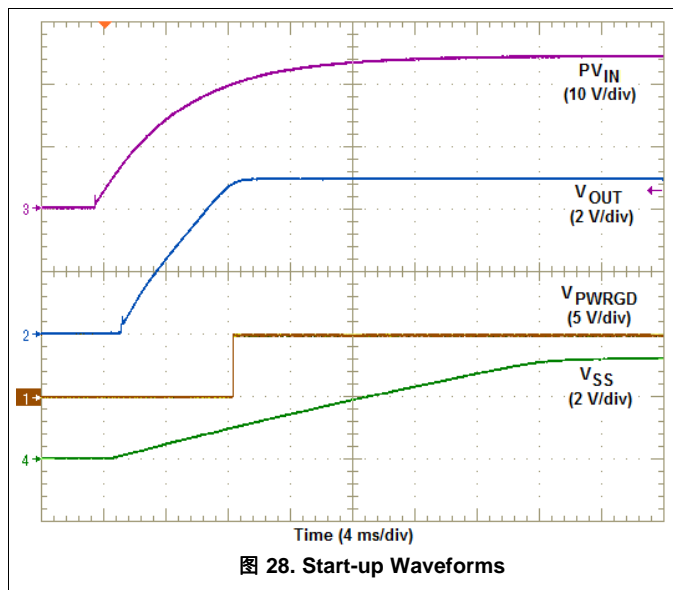
图 30 shows a more typical use schematic which makes use of the INH control, Versa-Comp, SS, PWRGD and PWRGD_PU features, along with adjusting the switching frequency with an external resistor. Setting these additional features is described below.

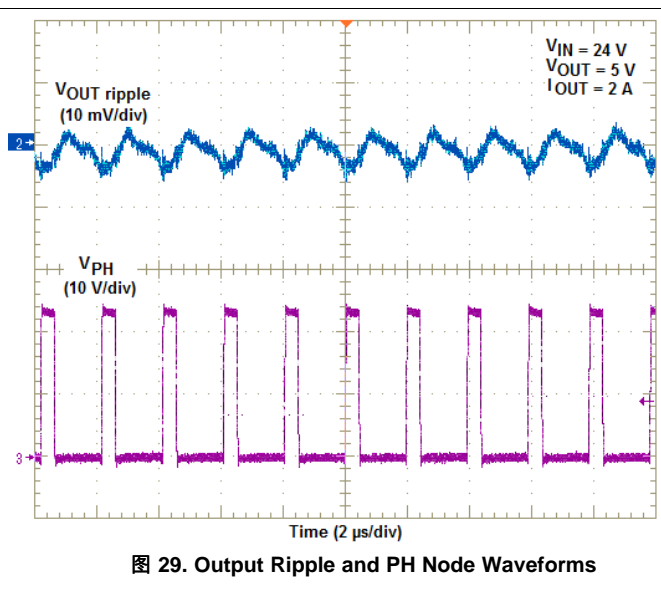

图 30. LMZ34202 Typical Schematic

8.2.2.1 Design Requirements

For this design example, use the parameters listed in 表 13 as the input parameters. For the complete design procedures start with the procedures for the basic application above as well as the procedures listed below.

表 13. Design Example Parameters

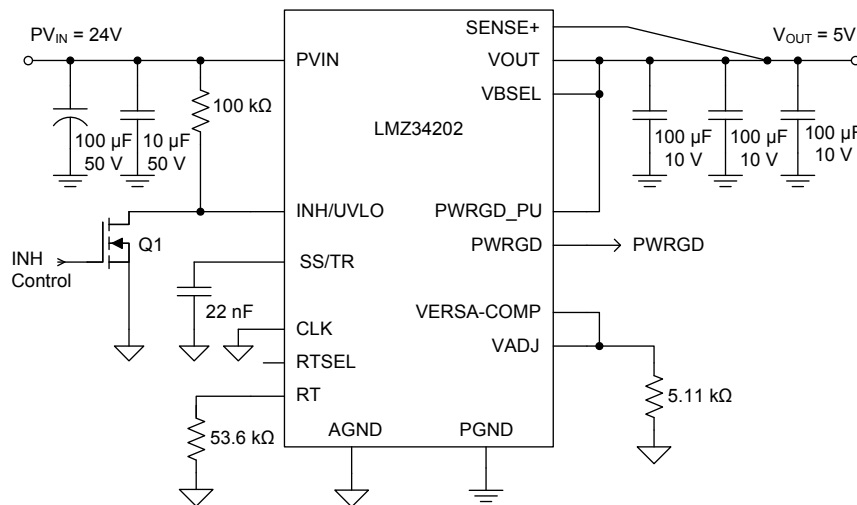
DESIGN PARAMETER	VALUE
Input Voltage PV_{IN}	24 V typical
Output Voltage V_{OUT}	5.0 V
Output Current Rating	2 A

表 13. Design Example Parameters (接下页)

DESIGN PARAMETER	VALUE
Operating Frequency	750 kHz
Inhibit Control	Yes
Power Good Signal	Yes
Slow Start Time	10 ms
Output Capacitance	300 μ F

8.2.3 Detailed Design Procedure

8.2.3.1 Switching Frequency

To adjust the switching frequency place a resistor between the RT pin (pin 9) and AGND. Refer to [表 3](#) to select the required value for R_{RT} resistor. To set the switching frequency to 750 kHz, the value for R_{RT} is 53.6 k Ω , selected from [表 3](#).

8.2.3.2 Power Good

The PWRGD pin is an open drain output. The LMZ34202 includes an internal 100 k Ω pullup resistor between the PWRGD pin and the PWRGD_PU pin. Connecting the PWRGD_PU pin to a pullup voltage allows use of the PWRGD signal without adding an additional component. In this example, the 5-V output is used as the pullup voltage.

8.2.3.3 Inhibit Control

To control the turn ON and OFF of the LMZ34202, an open-drain and collector device is recommended. The open-drain and collector device must be rated for the maximum voltage applied to PVIN. A pull-up resistor is required between the INH/UVLO pin and PVIN. Place a 100-k Ω resistor between the INH/UVLO pin and the PVIN pin.

8.2.3.4 VERSA-COMP

The Versa-Comp feature of the LMZ34202 configures the internal compensation based on the output voltage. From [表 8](#), the required Versa-Comp configuration for a 5-V output is to connect the VERSA-COMP pin to the VADJ pin.

8.2.3.5 VBSEL

The VBSEL pin allows the user to select the input source to the internal power circuitry to improve efficiency. For output voltages ≥ 4.5 V, connect this pin to VOUT. For output voltages < 4.5 V, connect this pin to AGND.

8.2.3.6 Soft-Start Capacitors

When the SS/TRK pin remains floating the LMZ34202 implements a typical soft-start time of 4.1 ms. In order to increase the slow start time, an external slow start capacitor, C_{SS} must be placed between the SS/TRK pin and AGND. Select a value for C_{SS} from [表 11](#).

For the desired soft-start time of 10 ms, a soft-start capacitor value of 22 nF is selected from [表 11](#).

8.2.3.7 Input Capacitors

For this design, a 10- μ F ceramic capacitor plus a 100- μ F aluminum electrolytic capacitor, both rated for 50 V are used for the input decoupling capacitors.

8.2.3.8 Output Capacitors

The maximum allowable output capacitance for a 5-V output is 350 μ F of capacitance. At least 64 μ F of capacitance must be ceramic type. For this design, 3 \times 100- μ F, X5R dielectric ceramic capacitors rated for 10 V are used for the output capacitors.

9 Power Supply Recommendations

The LMZ34202 is designed to operate from an input voltage supply range between 4.5 V and 42 V. This input supply should be well regulated and able to withstand maximum input current and maintain a stable voltage. The resistance of the input supply rail should be low enough that an input current transient does not cause a high enough drop at the LMZ34202 supply voltage that can cause a false UVLO fault triggering and system reset.

If the input supply is located more than a few inches from the LMZ34202 additional bulk capacitance may be required in addition to the ceramic bypass capacitors. The typical amount of bulk capacitance is 47 μF or the typical amount of electrolytic capacitance is 100 μF .

10 Layout

The performance of any switching power supply depends as much upon the layout of the PCB as the component selection. The following guidelines will help users design a PCB with the best power conversion performance, thermal performance, and minimized generation of unwanted EMI.

10.1 Layout Guidelines

To achieve optimal electrical and thermal performance, an optimized PCB layout is required. 图 31 thru 图 34, shows a typical PCB layout. Some considerations for an optimized layout are:

- Use large copper areas for power planes (PVIN, VOUT, and PGND) to minimize conduction loss and thermal stress.
- Place ceramic input and output capacitors close to the device pins to minimize high frequency noise.
- Locate additional output capacitors between the ceramic capacitor and the load.
- Keep AGND and PGND separate from one another. The connection is made internal to the device.
- Place R_{SET} , R_{RT} , and C_{SS} as close as possible to their respective pins.
- Use multiple vias to connect the power planes to internal layers.

10.2 Layout Example

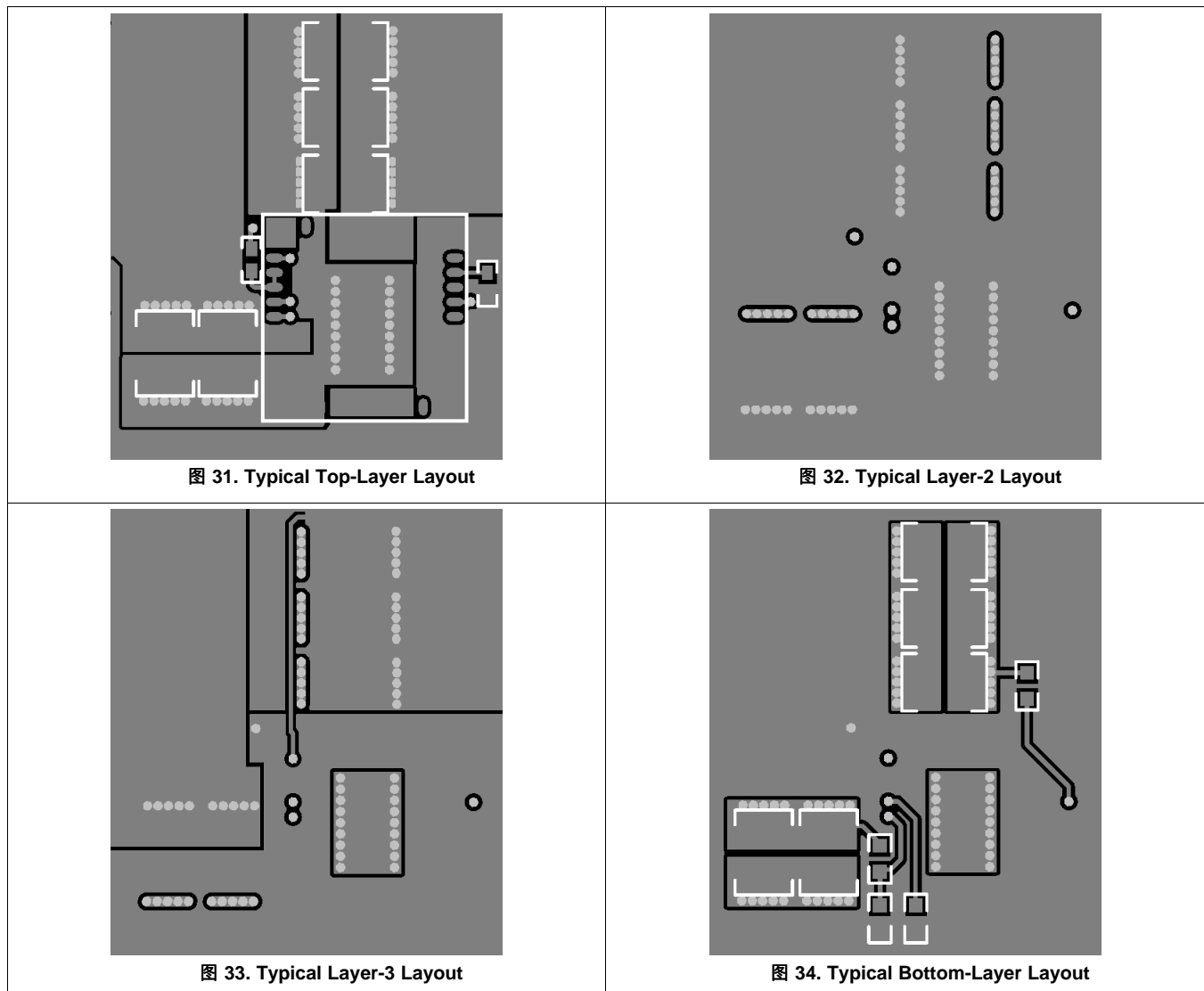

10.3 EMI

The LMZ34202 is compliant with EN55022 Class B radiated emissions. 图 35 图 36 show typical examples of radiated emissions plots for the LMZ34202 operating from 24 V. Both graphs include the plots of the antenna in the horizontal and vertical positions.

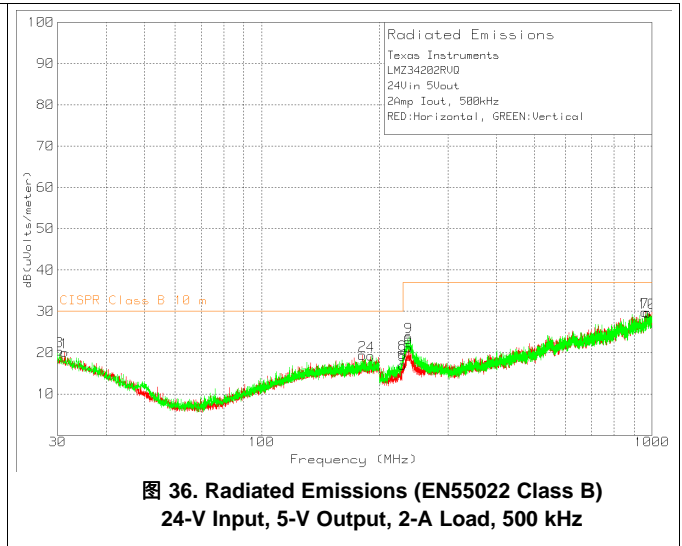
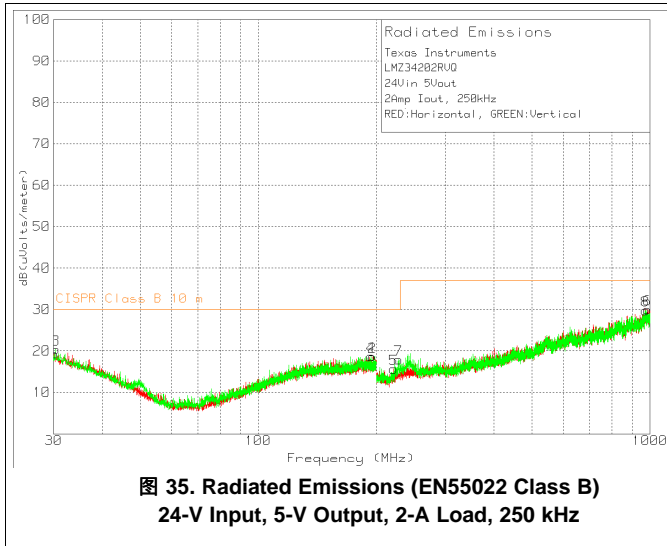

11 器件和文档支持

11.1 器件支持

11.1.1 开发支持

11.1.1.1 使用 **WEBENCH®** 工具创建定制设计

单击[此处](#)，使用 LMZ34202 器件并借助 WEBENCH® 电源设计器创建定制设计方案。

1. 首先键入输入电压 (V_{IN})、输出电压 (V_{OUT}) 和输出电流 (I_{OUT}) 要求。
2. 使用优化器拨盘优化该设计的关键参数，如效率、尺寸和成本。
3. 将生成的设计与德州仪器 (TI) 的其他可行解决方案进行比较。

WEBENCH 电源设计器可提供定制原理图以及罗列实时价格和组件供货情况的物料清单。

在多数情况下，可执行以下操作：

- 运行电气仿真，观察重要波形以及电路性能
- 运行热性能仿真，了解电路板热性能
- 将定制原理图和布局方案以常用 CAD 格式导出
- 打印设计方案的 PDF 报告并与同事共享

有关 WEBENCH 工具的详细信息，请访问 www.ti.com.cn/WEBENCH。

11.1.2 第三方产品免责声明

TI 发布的与第三方产品或服务有关的信息，不能构成与此类产品或服务或保修的适用性有关的认可，不能构成此类产品或服务单独或与任何 TI 产品或服务一起的表示或认可。

11.2 接收文档更新通知

要接收文档更新通知，请导航至 TI.com.cn 上的器件产品文件夹。单击右上角的 [通知我](#) 进行注册，即可每周接收产品信息更改摘要。有关更改的详细信息，请查看任何已修订文档中包含的修订历史记录。

11.3 社区资源

下列链接提供到 TI 社区资源的连接。链接的内容由各个分销商“按照原样”提供。这些内容并不构成 TI 技术规范，并且不一定反映 TI 的观点；请参阅 TI 的 [《使用条款》](#)。

TI E2E™ 在线社区 [TI 的工程师对工程师 \(E2E\) 社区](#)。此社区的创建目的在于促进工程师之间的协作。在 e2e.ti.com 中，您可以咨询问题、分享知识、拓展思路并与同行工程师一道帮助解决问题。

设计支持 [TI 参考设计支持](#) 可帮助您快速查找有帮助的 E2E 论坛、设计支持工具以及技术支持的联系信息。

11.4 商标

E2E is a trademark of Texas Instruments.

WEBENCH is a registered trademark of Texas Instruments.

All other trademarks are the property of their respective owners.

11.5 静电放电警告



这些装置包含有限的内置 ESD 保护。存储或装卸时，应将导线一起截短或将装置放置于导电泡棉中，以防止 MOS 门极遭受静电损伤。

11.6 术语表

SLYZ022 — TI 术语表。

这份术语表列出并解释术语、缩写和定义。

12 机械、封装和可订购信息

以下页面包含机械、封装和可订购信息。这些信息是指定器件的最新可用数据。数据如有变更，恕不另行通知，且不会对此文档进行修订。如需获取此产品说明书的浏览器版本，请参阅左侧的导航栏。

PACKAGING INFORMATION

Orderable part number	Status (1)	Material type (2)	Package Pins	Package qty Carrier	RoHS (3)	Lead finish/ Ball material (4)	MSL rating/ Peak reflow (5)	Op temp (°C)	Part marking (6)
LMZ34202RVQR	Active	Production	B3QFN (RVQ) 43	500 LARGE T&R	Exempt	NIPDAU	Level-3-245C-168 HR	-40 to 105	LMZ34202
LMZ34202RVQR.A	Active	Production	B3QFN (RVQ) 43	500 LARGE T&R	Exempt	NIPDAU	Level-3-245C-168 HR	-40 to 105	LMZ34202
LMZ34202RVQT	Active	Production	B3QFN (RVQ) 43	250 SMALL T&R	Yes	NIPDAU	Level-3-245C-168 HR	-40 to 105	LMZ34202
LMZ34202RVQT.A	Active	Production	B3QFN (RVQ) 43	250 SMALL T&R	Yes	NIPDAU	Level-3-245C-168 HR	-40 to 105	LMZ34202

(1) **Status:** For more details on status, see our [product life cycle](#).

(2) **Material type:** When designated, preproduction parts are prototypes/experimental devices, and are not yet approved or released for full production. Testing and final process, including without limitation quality assurance, reliability performance testing, and/or process qualification, may not yet be complete, and this item is subject to further changes or possible discontinuation. If available for ordering, purchases will be subject to an additional waiver at checkout, and are intended for early internal evaluation purposes only. These items are sold without warranties of any kind.

(3) **RoHS values:** Yes, No, RoHS Exempt. See the [TI RoHS Statement](#) for additional information and value definition.

(4) **Lead finish/Ball material:** Parts may have multiple material finish options. Finish options are separated by a vertical ruled line. Lead finish/Ball material values may wrap to two lines if the finish value exceeds the maximum column width.

(5) **MSL rating/Peak reflow:** The moisture sensitivity level ratings and peak solder (reflow) temperatures. In the event that a part has multiple moisture sensitivity ratings, only the lowest level per JEDEC standards is shown. Refer to the shipping label for the actual reflow temperature that will be used to mount the part to the printed circuit board.

(6) **Part marking:** There may be an additional marking, which relates to the logo, the lot trace code information, or the environmental category of the part.

Multiple part markings will be inside parentheses. Only one part marking contained in parentheses and separated by a "~" will appear on a part. If a line is indented then it is a continuation of the previous line and the two combined represent the entire part marking for that device.

Important Information and Disclaimer: The information provided on this page represents TI's knowledge and belief as of the date that it is provided. TI bases its knowledge and belief on information provided by third parties, and makes no representation or warranty as to the accuracy of such information. Efforts are underway to better integrate information from third parties. TI has taken and continues to take reasonable steps to provide representative and accurate information but may not have conducted destructive testing or chemical analysis on incoming materials and chemicals. TI and TI suppliers consider certain information to be proprietary, and thus CAS numbers and other limited information may not be available for release.

In no event shall TI's liability arising out of such information exceed the total purchase price of the TI part(s) at issue in this document sold by TI to Customer on an annual basis.

TAPE AND REEL INFORMATION

QUADRANT ASSIGNMENTS FOR PIN 1 ORIENTATION IN TAPE

*All dimensions are nominal

Device	Package Type	Package Drawing	Pins	SPQ	Reel Diameter (mm)	Reel Width W1 (mm)	A0 (mm)	B0 (mm)	K0 (mm)	P1 (mm)	W (mm)	Pin1 Quadrant
LMZ34202RVQR	B3QFN	RVQ	43	500	330.0	24.4	10.35	10.35	4.6	16.0	24.0	Q2
LMZ34202RVQT	B3QFN	RVQ	43	250	330.0	24.4	10.35	10.35	4.6	16.0	24.0	Q2

TAPE AND REEL BOX DIMENSIONS

*All dimensions are nominal

Device	Package Type	Package Drawing	Pins	SPQ	Length (mm)	Width (mm)	Height (mm)
LMZ34202RVQR	B3QFN	RVQ	43	500	383.0	353.0	58.0
LMZ34202RVQT	B3QFN	RVQ	43	250	383.0	353.0	58.0

RVQ0043A

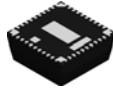

PACKAGE OUTLINE

B3QFN - 4.4mm max height

PLASTIC QUAD FLATPACK - NO LEAD

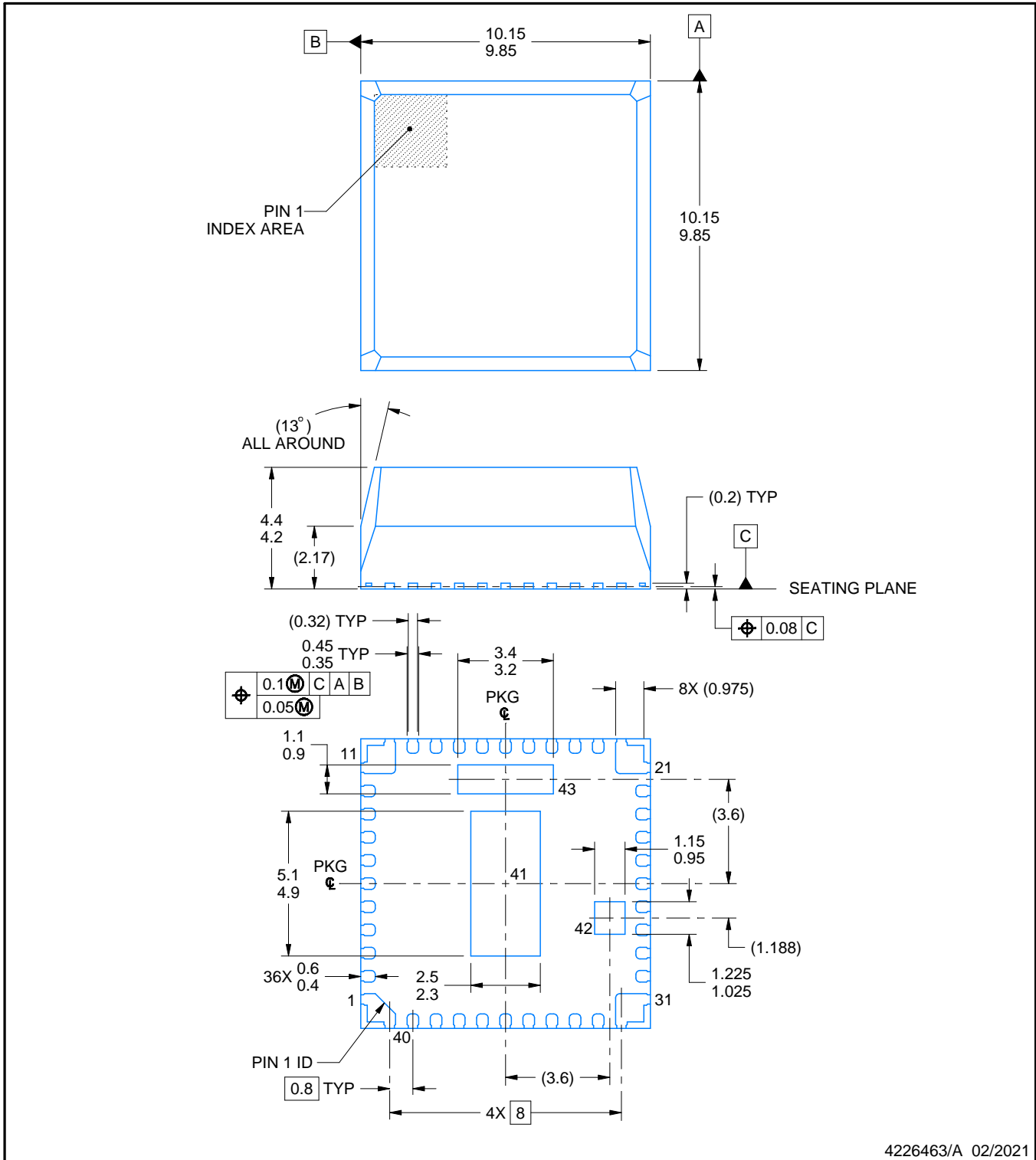

4226463/A 02/2021

NOTES:

- 1. All linear dimensions are in millimeters. Any dimensions in parenthesis are for reference only. Dimensioning and tolerancing per ASME Y14.5M.
- 2. This drawing is subject to change without notice.
- 3. The package thermal pads must be soldered to the printed circuit board for optimal thermal and mechanical performance.

EXAMPLE BOARD LAYOUT

RVQ0043A

B3QFN - 4.4mm max height

PLASTIC QUAD FLATPACK - NO LEAD

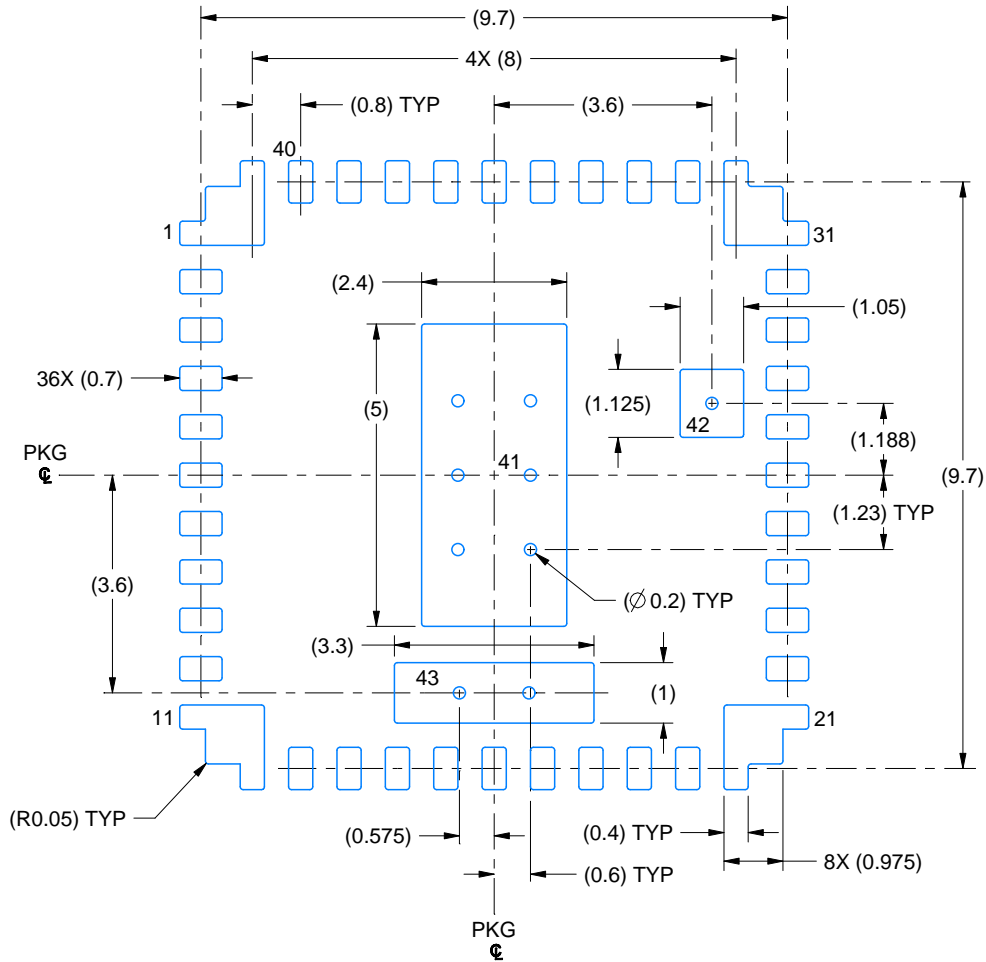

LAND PATTERN EXAMPLE
EXPOSED METAL SHOWN
SCALE:8X

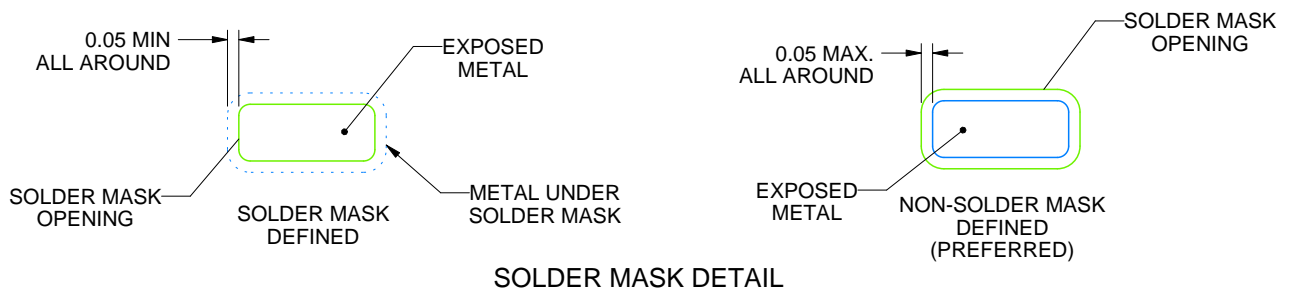

SOLDER MASK DETAIL

4226463/A 02/2021

NOTES: (continued)

4. This package designed to be soldered to a thermal pads on the board. For more information, see Texas Instruments literature number SLUA271 (www.ti.com/lit/slue271).
5. Vias are optional depending on application, refer to device data sheet. If any vias are implemented, refer to their locations shown on this view. It is recommended that vias under paste be filled, plugged or tented.

EXAMPLE STENCIL DESIGN

RVQ0043A

B3QFN - 4.4mm max height

PLASTIC QUAD FLATPACK - NO LEAD

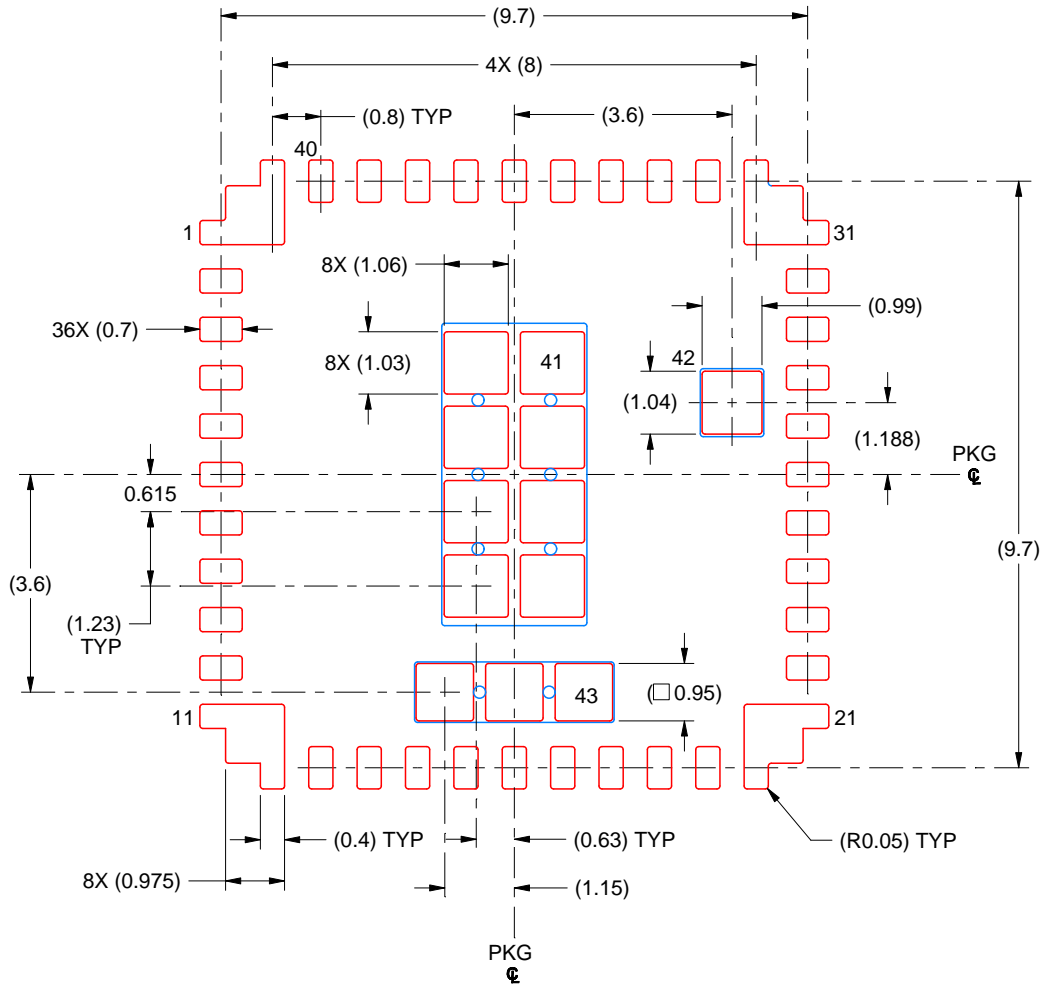

SOLDER PASTE EXAMPLE
 BASED ON 0.1 mm STENCIL THICKNESS

EXPOSED PAD 41:
 73% PRINTED SOLDER COVERAGE BY AREA UNDER PACKAGE

EXPOSED PAD 42:
 87% PRINTED SOLDER COVERAGE BY AREA UNDER PACKAGE

EXPOSED PAD 43:
 82% PRINTED SOLDER COVERAGE BY AREA UNDER PACKAGE
 SCALE:8X

4226463/A 02/2021

NOTES: (continued)

6. Laser cutting apertures with trapezoidal walls and rounded corners may offer better paste release. IPC-7525 may have alternate design recommendations.

重要通知和免责声明

TI“按原样”提供技术和可靠性数据（包括数据表）、设计资源（包括参考设计）、应用或其他设计建议、网络工具、安全信息和其他资源，不保证没有瑕疵且不做任何明示或暗示的担保，包括但不限于对适销性、与某特定用途的适用性或不侵犯任何第三方知识产权的暗示担保。

这些资源可供使用 TI 产品进行设计的熟练开发人员使用。您将自行承担以下全部责任：(1) 针对您的应用选择合适的 TI 产品，(2) 设计、验证并测试您的应用，(3) 确保您的应用满足相应标准以及任何其他安全、安保法规或其他要求。

这些资源如有变更，恕不另行通知。TI 授权您仅可将这些资源用于研发本资源所述的 TI 产品的相关应用。严禁以其他方式对这些资源进行复制或展示。您无权使用任何其他 TI 知识产权或任何第三方知识产权。对于因您对这些资源的使用而对 TI 及其代表造成的任何索赔、损害、成本、损失和债务，您将全额赔偿，TI 对此概不负责。

TI 提供的产品受 [TI 销售条款](#)、[TI 通用质量指南](#) 或 [ti.com](#) 上其他适用条款或 TI 产品随附的其他适用条款的约束。TI 提供这些资源并不会扩展或以其他方式更改 TI 针对 TI 产品发布的适用的担保或担保免责声明。除非德州仪器 (TI) 明确将某产品指定为定制产品或客户特定产品，否则其产品均为按确定价格收入目录的标准通用器件。

TI 反对并拒绝您可能提出的任何其他或不同的条款。

版权所有 © 2026，德州仪器 (TI) 公司

最后更新日期：2025 年 10 月