

LM284x SIMPLE SWITCHER® 4.5V 至 42V 输入、0.1/0.3/ 0.6A 输出降压直流/直流稳压器，采用超薄 SOT 封装

1 特性

- 4.5V 至 42V 输入电压
- 100mA、300mA 和 600mA 输出电流选项
- 0.765V 反馈引脚电压
- 550kHz (X) 或 1.25MHz (Y) 开关频率
- 低关断 I_Q : 16 μ A 典型值
- 短路保护
- 内部补偿
- 软启动电路
- 小型总体解决方案尺寸 (SOT-6L 封装)
- 使用 LM2840 (或 LM2841/42) 并借助 [WEBENCH® 电源设计器](#) 进行定制设计

2 应用

- 电池供电类设备
- 工业分布式电源 应用
- 便携式媒体播放器
- 便携式手持仪器

3 说明

LM284x SIMPLE SWITCHER™ 器件是 PWM 直流/直流降压稳压器。该器件具有 4.5V 至 42V 的输入范围，适合各种应用（例如，从非稳压源进行电源调节）。它们具有低 $R_{DS(ON)}$ （典型值 0.9 Ω ）内部开关，可实现最大效率（典型值 85%）。此外，它们还具有 550kHz (X 选项) 和 1.25MHz (Y 选项) 的固定工作频率，可在保证低输出电压纹波的同时支持小型外部组件。可通过结合使用关断 (SHDN) 引脚和外部 RC 电路来执行软启动，从而方便用户根据特定应用调整软启动时间。

经过优化后，LM2840 的负载电流高达 100mA，LM2841 的负载电流高达 300mA，LM2842 的负载电流则高达 600mA。它们都具有 0.765V 的标称反馈电压。

此器件还提供其他特性包括：热关断、 V_{IN} 欠压锁定和栅极驱动欠压锁定。LM284x 都采用低厚度 SOT-6L 封装。

器件信息⁽¹⁾

器件型号	封装	封装尺寸 (标称值)
LM2840、LM2841、LM2842	SOT (6)	1.60mm x 2.90mm

(1) 如需了解所有可用封装，请参阅产品说明书末尾的可订购产品附录。

典型应用电路

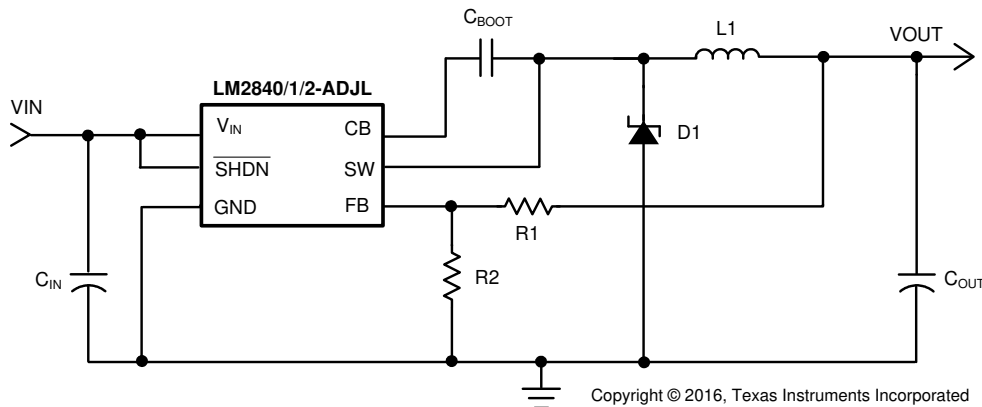

目录

1	特性	1	8	Application and Implementation	11
2	应用	1	8.1	Application Information.....	11
3	说明	1	8.2	Typical Applications	11
4	修订历史记录	2	9	Power Supply Recommendations	16
5	Pin Configuration and Functions	3	10	Layout	16
6	Specifications	4	10.1	Layout Guidelines	16
6.1	Absolute Maximum Ratings	4	10.2	Layout Example	16
6.2	ESD Ratings.....	4	11	器件和文档支持	17
6.3	Recommended Operating Conditions.....	4	11.1	器件支持	17
6.4	Thermal Information	4	11.2	文档支持	17
6.5	Electrical Characteristics	5	11.3	相关链接	17
6.6	Typical Characteristics	7	11.4	接收文档更新通知	17
7	Detailed Description	9	11.5	社区资源	17
7.1	Overview	9	11.6	商标	18
7.2	Functional Block Diagram	9	11.7	静电放电警告	18
7.3	Feature Description.....	9	11.8	Glossary	18
7.4	Device Functional Modes.....	10	12	机械、封装和可订购信息	18

4 修订历史记录

注：之前版本的页码可能与当前版本有所不同。

Changes from Revision J (February 2017) to Revision K	Page
• 将汽车数据表拆分为单独的文档 (SNVSBE5) 并从 SNVS540 中删除了特定于汽车的内容	1
• 已添加 在数据表标题中添加了 SIMPLE SWITCHER®	1

Changes from Revision I (September 2016) to Revision J	Page
• Added new text for Pin 4	3
• Added this new line of text in Shutdown Operation section	13

Changes from Revision H (April 2013) to Revision I	Page
• 添加了 ESD 额定值表、特性说明部分、器件功能模式、应用和实施部分、电源相关建议部分、布局部分、器件和文档支持部分以及机械、封装和可订购信息部分。	1
• Added Thermal Information table	4

Changes from Revision G (April 2013) to Revision H	Page
• 已更改 将美国国家半导体数据表的布局更改为 TI 格式	1

5 Pin Configuration and Functions

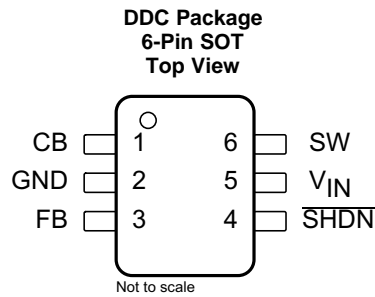

Pin Functions

PIN		I/O	DESCRIPTION
NO.	NAME		
1	CB	I	SW FET gate bias voltage. Connect C_{BOOT} capacitor between CB and SW.
2	GND	—	Ground connection
3	FB	I	Feedback pin: Set feedback voltage divider ratio with $V_{OUT} = V_{FB} (1 + (R1 / R2))$. Resistors must be from 100 Ω to 10 k Ω to avoid input bias errors.
4	$\overline{\text{SHDN}}$	I	Logic level shutdown input. Pull to GND to disable the device and pull high to enable the device. If this function is not used tie to V_{IN} . DO NOT ALLOW TO FLOAT.
5	V_{IN}	I	Power input voltage pin: 4.5-V to 42-V normal operating range.
6	SW	O	Power FET output: Connect to inductor, diode, and C_{BOOT} capacitor.

6 Specifications

6.1 Absolute Maximum Ratings

See ⁽¹⁾⁽²⁾

	MIN	MAX	UNIT
V_{IN}	-0.3	45	V
\overline{SHDN}	-0.3	$(V_{IN} + 0.3 \text{ V}) < 45$	V
SW voltage	-0.3	45	V
CB voltage above SW voltage		7	V
FB voltage	-0.3	5	V
Power dissipation ⁽³⁾	Internally Limited		
Maximum junction temperature		150	°C
Storage temperature, T_{stg}	-65	150	°C

- Stresses beyond those listed under *Absolute Maximum Ratings* may cause permanent damage to the device. These are stress ratings only, which do not imply functional operation of the device at these or any other conditions beyond those indicated under *Recommended Operating Conditions*. Exposure to absolute-maximum-rated conditions for extended periods may affect device reliability.
- If Military/Aerospace specified devices are required, contact the Texas Instruments Sales Office/Distributors for availability and specifications.
- The maximum allowable power dissipation is a function of the maximum junction temperature, $T_{J(MAX)}$, the junction-to-ambient thermal resistance, $R_{\theta JA}$, and the ambient temperature, T_A . The maximum allowable power dissipation at any ambient temperature is calculated using: $P_D (MAX) = (T_{J(MAX)} - T_A) / R_{\theta JA}$. Exceeding the maximum allowable power dissipation causes excessive die temperature, and the regulator goes into thermal shutdown. Internal thermal shutdown circuitry protects the device from permanent damage. Thermal shutdown engages at $T_J=175^\circ\text{C}$ (typical) and disengages at $T_J= 155^\circ\text{C}$ (typical).

6.2 ESD Ratings

	VALUE	UNIT
$V_{(ESD)}$ Electrostatic discharge Human-body model (HBM), per ANSI/ESDA/JEDEC JS-001 ⁽¹⁾	±2000	V

- JEDEC document JEP155 states that 500-V HBM allows safe manufacturing with a standard ESD control process.

6.3 Recommended Operating Conditions

over operating free-air temperature range (unless otherwise noted)

	MIN	MAX	UNIT
Operating junction temperature ⁽¹⁾	-40	125	°C
Input voltage V_{IN}	4.5	42	V
SW voltage		42	V

- All limits specified at room temperature ($T_A = 25^\circ\text{C}$) unless otherwise specified. All room temperature limits are 100% production tested. All limits at temperature extremes are ensured through correlation using standard Statistical Quality Control (SQC) methods. All limits are used to calculate Average Outgoing Quality Level (AOQL).

6.4 Thermal Information

THERMAL METRIC ⁽¹⁾		LM284x	UNIT
		DDC (SOT)	
		6 PINS	
$R_{\theta JA}$	Junction-to-ambient thermal resistance ⁽²⁾⁽³⁾	121	°C/W
$R_{\theta JC(top)}$	Junction-to-case (top) thermal resistance	94	°C/W

- For more information about traditional and new thermal metrics, see the *Semiconductor and IC Package Thermal Metrics* application report.
- The package thermal impedance is calculated in accordance to JESD 51-7.
- Thermal Resistances were simulated on a 4-layer, JEDEC board

6.5 Electrical Characteristics

Specifications are for $T_J = 25^\circ\text{C}$ unless otherwise specified. Minimum and Maximum limits are specified through test, design, or statistical correlation. Typical values represent the most likely parametric norm at $T_J = 25^\circ\text{C}$, and are provided for reference purposes only. Unless otherwise stated the following conditions apply: $V_{IN} = 12\text{ V}$.⁽¹⁾⁽²⁾⁽³⁾

PARAMETER		TEST CONDITIONS		MIN	TYP	MAX	UNIT	
I_Q	Quiescent current	$\overline{\text{SHDN}} = 0\text{ V}$			16		μA	
			$T_J = -40^\circ\text{C}$ to 125°C			40		
		Device ON, not switching				1.3		mA
			$T_J = -40^\circ\text{C}$ to 125°C				1.75	
Device ON, no load				1.35		mA		
$T_J = -40^\circ\text{C}$ to 125°C					1.85			
$R_{\text{DS(ON)}}$	Switch ON resistance	See ⁽⁴⁾			0.9		Ω	
			$T_J = -40^\circ\text{C}$ to 125°C					1.6
I_{LSW}	Switch leakage current	$V_{\text{IN}} = 42\text{ V}$			0		μA	
			$T_J = -40^\circ\text{C}$ to 125°C					0.5
I_{CL}	Switch current limit	LM2840 ⁽⁵⁾			525		mA	
			$T_J = -40^\circ\text{C}$ to 125°C					900
		LM2841 ⁽⁵⁾				525		mA
			$T_J = -40^\circ\text{C}$ to 125°C				900	
		LM2842 ⁽⁵⁾				1.15		A
			$T_J = -40^\circ\text{C}$ to 125°C				1.7	
I_{FB}	Feedback pin bias current	LM284[0,1,2] ⁽⁶⁾			0.1		μA	
			$T_J = -40^\circ\text{C}$ to 125°C					1
V_{FB}	FB Pin reference voltage				0.765		V	
		$T_J = -40^\circ\text{C}$ to 125°C			0.747			0.782
$t_{\text{ON(min)}}$	Minimum ON-time	See ⁽⁷⁾			100		ns	
			$T_J = -40^\circ\text{C}$ to 125°C					150
$t_{\text{OFF(min)}}$	Minimum OFF-time	X option			110		ns	
			$T_J = -40^\circ\text{C}$ to 125°C					370
		Y option				104		ns
			$T_J = -40^\circ\text{C}$ to 125°C				200	
f_{SW}	Switching frequency	X option, $V_{\text{FB}} = 0.5\text{ V}$			550		kHz	
			$T_J = -40^\circ\text{C}$ to 125°C			325		
		X option, $V_{\text{FB}} = 0\text{ V}$				140		MHz
		Y option, $V_{\text{FB}} = 0.5\text{ V}$				1.25		
			$T_J = -40^\circ\text{C}$ to 125°C			0.95		
		Y option, $V_{\text{FB}} = 0\text{ V}$				0.35		
D_{MAX}	Maximum duty cycle	X option			94%			
			$T_J = -40^\circ\text{C}$ to 125°C			88%		
		Y option				87%		
			$T_J = -40^\circ\text{C}$ to 125°C			81%		

(1) All limits specified at room temperature ($T_A = 25^\circ\text{C}$) unless otherwise noted. Room temperature limits are production tested. Limits at temperature extremes are ensured through correlation using standard Statistical Quality Control (SQC) methods. Limits are used to calculate Average Outgoing Quality Level (AOQL).

(2) Typical numbers are at 25°C and represent the most likely norm.

(3) The part numbers in this table represent both the Q1 and non-Q1 versions of the respective parts.

(4) Includes the bond wires, $R_{\text{DS(ON)}}$ from V_{IN} pin to SW pin.

(5) Current limit at 0% duty cycle. May be lower at higher duty cycle or input voltages below 6 V.

(6) Bias currents flow into pin.

(7) Minimum ON-time specified by design and simulation.

Electrical Characteristics (continued)

Specifications are for $T_J = 25^\circ\text{C}$ unless otherwise specified. Minimum and Maximum limits are specified through test, design, or statistical correlation. Typical values represent the most likely parametric norm at $T_J = 25^\circ\text{C}$, and are provided for reference purposes only. Unless otherwise stated the following conditions apply: $V_{IN} = 12\text{ V}$.⁽¹⁾⁽²⁾⁽³⁾

PARAMETER		TEST CONDITIONS		MIN	TYP	MAX	UNIT
V_{UVP}	Undervoltage lockout thresholds	On threshold			3.7		V
			$T_J = -40^\circ\text{C}$ to 125°C	4.4			
		Off threshold			3.5		
			$T_J = -40^\circ\text{C}$ to 125°C			3.25	
$V_{\overline{\text{SHDN}}}$	Shutdown threshold	Device ON			1		V
			$T_J = -40^\circ\text{C}$ to 125°C	2.3			
		Device OFF			0.9		
			$T_J = -40^\circ\text{C}$ to 125°C			0.3	
$I_{\overline{\text{SHDN}}}$	Shutdown pin input bias current	$V_{\overline{\text{SHDN}}} = 2.3\text{ V}^{(6)}$			0.05		μA
			$T_J = -40^\circ\text{C}$ to 125°C			1.5	
		$V_{\overline{\text{SHDN}}} = 0\text{ V}$			0.02		
			$T_J = -40^\circ\text{C}$ to 125°C			1.5	

6.6 Typical Characteristics

The part numbers in this section represent both the Q1 and non-Q1 versions of the respective parts.

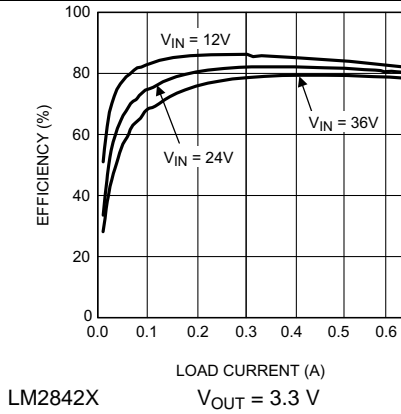

Figure 1. Efficiency vs Load Current

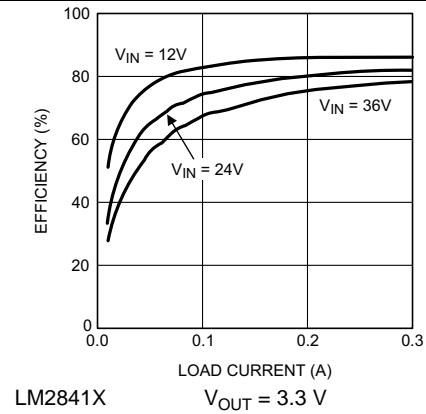

Figure 2. Efficiency vs Load Current

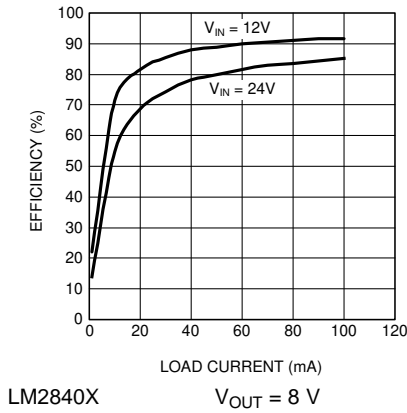

Figure 3. Efficiency vs Load Current

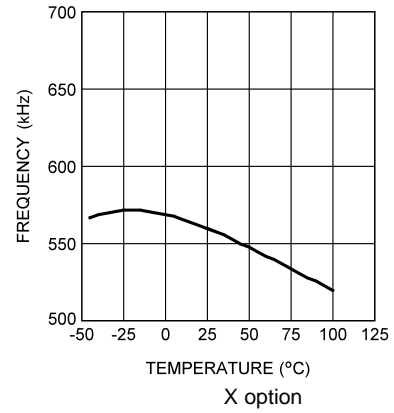

Figure 4. Switching Frequency vs Temperature

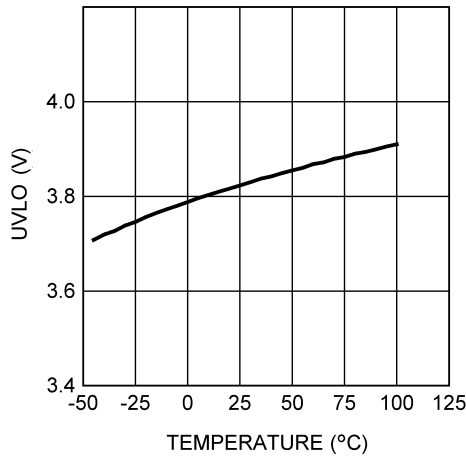

Figure 5. Input UVLO Voltage vs Temperature

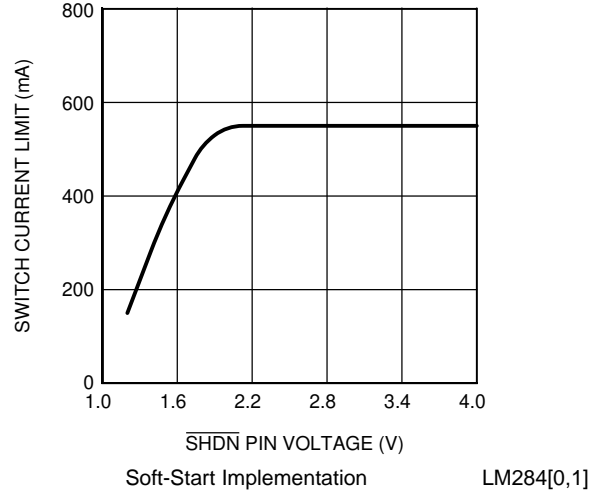
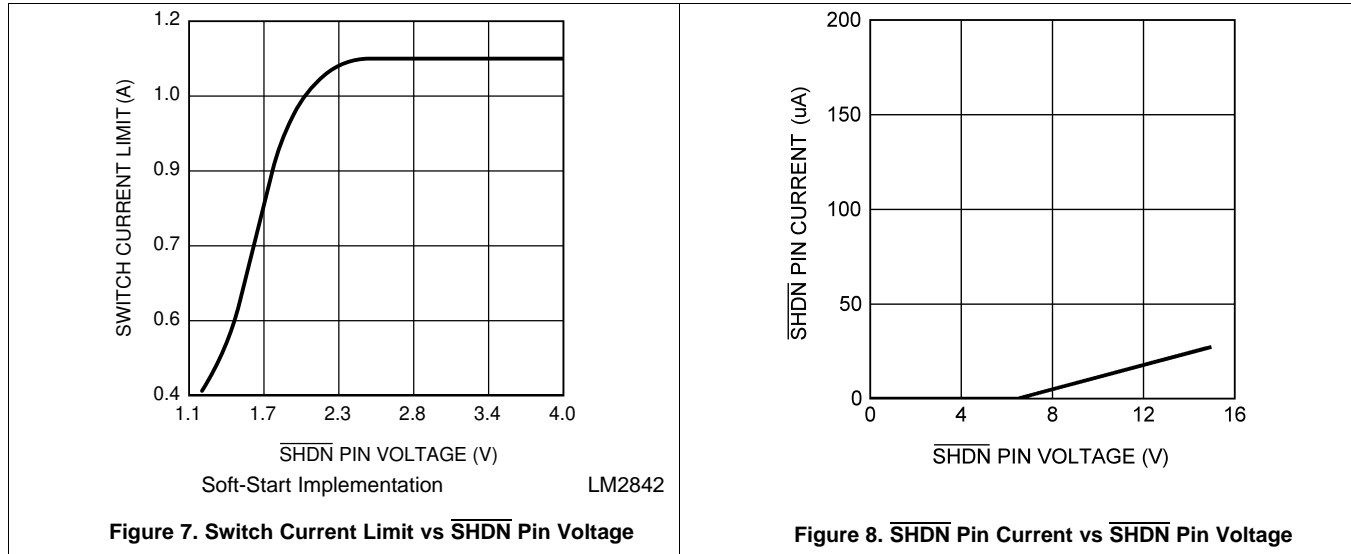

Figure 6. Switch Current Limit vs $\overline{\text{SHDN}}$ Pin Voltage

Typical Characteristics (continued)

The part numbers in this section represent both the Q1 and non-Q1 versions of the respective parts.



7 Detailed Description

7.1 Overview

The LM284x SIMPLE SWITCHER® regulators are easy-to-use, non-synchronous, step-down DC/DC converters with a wide input voltage range up to 42 V. The devices are capable of delivering up to 100-mA, 300-mA, or 600-mA DC load current with excellent line and load regulation. These devices are available in fixed frequency of 550 kHz and 1.25 MHz. The family requires few external components, and the pin arrangement was designed for simple, optimum PCB layout.

7.2 Functional Block Diagram

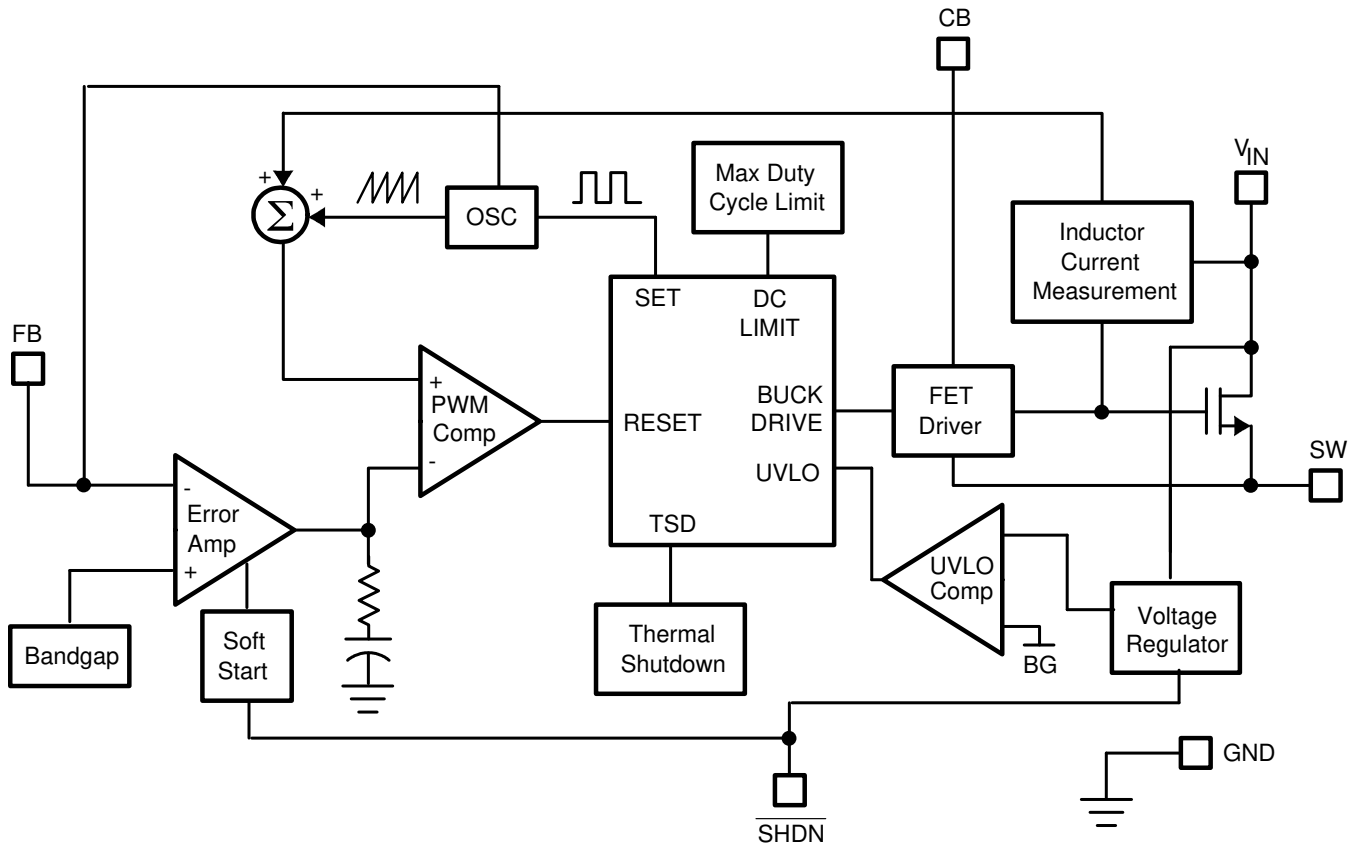

Copyright © 2016, Texas Instruments Incorporated

7.3 Feature Description

7.3.1 Protection

The LM284x have dedicated protection circuitry running during normal operation to protect the IC. The thermal shutdown circuitry turns off the power device when the die temperature reaches excessive levels. The UVLO comparator protects the power device during supply power start-up and shutdown to prevent operation at voltages less than the minimum input voltage. A gate drive (CB) undervoltage lockout is included to ensure that there is enough gate drive voltage to drive the MOSFET before the device tries to start switching. The LM284x also feature a shutdown mode decreasing the supply current to approximately 16 μ A.

7.4 Device Functional Modes

7.4.1 Continuous Conduction Mode

The LM284x contain a current-mode, PWM buck regulator. A buck regulator steps the input voltage down to a lower output voltage. In continuous conduction mode (when the inductor current never reaches zero at steady-state operation), the buck regulator operates in two cycles. The power switch is connected between V_{IN} and SW. In the first cycle of operation the transistor is closed and the diode is reverse biased. Energy is collected in the inductor and the load current is supplied by C_{OUT} and the rising current through the inductor. During the second cycle the transistor is open and the diode is forward biased due to the fact that the inductor current cannot instantaneously change direction. The energy stored in the inductor is transferred to the load and output capacitor. The ratio of these two cycles determines the output voltage. The output voltage is defined approximately as shown in [Equation 1](#).

$$D = V_{OUT} / V_{IN} \quad (1)$$

$$D' = (1 - D)$$

where

- D is the duty cycle of the switch (2)

D and D' are required for design calculations.

8 Application and Implementation

NOTE

Information in the following applications sections is not part of the TI component specification, and TI does not warrant its accuracy or completeness. TI's customers are responsible for determining suitability of components for their purposes. Customers should validate and test their design implementation to confirm system functionality.

8.1 Application Information

The LM284x are step-down DC/DC regulators. They are typically used to convert a higher DC voltage to a lower DC voltage with a maximum output current of 100 mA, 300 mA, or 600 mA. The following design procedure can be used to select components for the LM284x. Alternately, the WEBENCH® software may be used to generate complete designs. When generating a design, the WEBENCH software uses iterative design procedure and accesses comprehensive databases of components. See ti.com and [Detailed Design Procedure](#) for more details.

8.2 Typical Applications

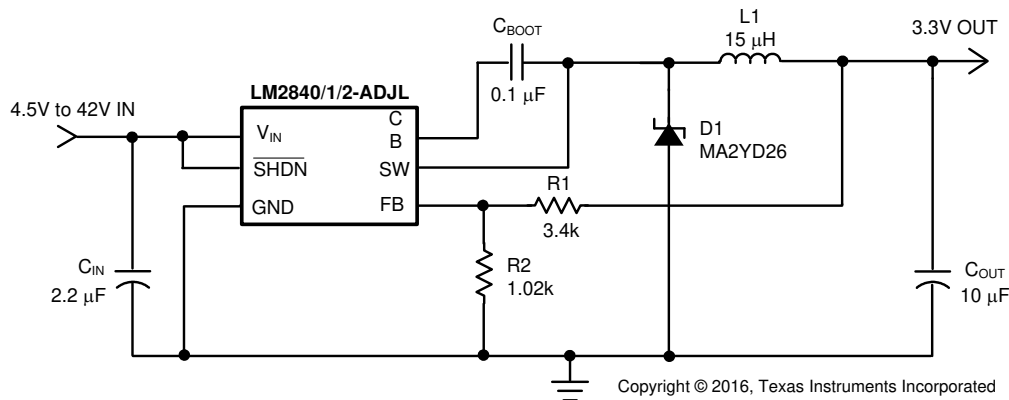

Figure 9. Application Circuit With 3.3-V Output Voltage at 100 mA

8.2.1 Design Requirements

Table 1 lists the design parameters for this example.

Table 1. Design Parameters

DESIGN PARAMETER	EXAMPLE VALUE
Input voltage	4.5 V to 42 V
Output voltage	3.3 V
Output current	0.1 A

8.2.2 Detailed Design Procedure

8.2.2.1 Custom Design With WEBENCH® Tools

[Click here](#) to create a custom design using the LM2840 device with the WEBENCH® Power Designer.

1. Start by entering the input voltage (V_{IN}), output voltage (V_{OUT}), and output current (I_{OUT}) requirements.
2. Optimize the design for key parameters such as efficiency, footprint, and cost using the optimizer dial.
3. Compare the generated design with other possible solutions from Texas Instruments.

The WEBENCH Power Designer provides a customized schematic along with a list of materials with real-time pricing and component availability.

In most cases, these actions are available:

- Run electrical simulations to see important waveforms and circuit performance

- Run thermal simulations to understand board thermal performance
- Export customized schematic and layout into popular CAD formats
- Print PDF reports for the design, and share the design with colleagues

Get more information about WEBENCH tools at www.ti.com/WEBENCH.

This section presents guidelines for selecting external components.

8.2.2.2 Setting the Output Voltage

The output voltage is set using the feedback pin and a resistor divider connected to the output as shown in [典型应用电路](#). The feedback pin voltage 0.765 V, so the ratio of the feedback resistors sets the output voltage according to [Equation 3](#):

$$V_{OUT} = 0.765 \text{ V} (1 + (R1 / R2)) \quad (3)$$

Typically R2 is given as 100 Ω to 10 kΩ for a starting value. To solve for R1 given R2 and V_{OUT} , use [Equation 4](#):

$$R1 = R2 ((V_{OUT} / 0.765 \text{ V}) - 1) \quad (4)$$

8.2.2.3 Inductor Selection

The most critical parameters for the inductor are the inductance, peak current, and the DC resistance. The inductance is related to the peak-to-peak inductor ripple current, the input and the output voltages.

$$L = \frac{(V_{IN} - V_{OUT})V_{OUT}}{V_{IN} \times I_{RIPPLE} \times f_{SW}} \quad (5)$$

A higher value of ripple current reduces inductance, but increases the conduction loss, core loss, and current stress for the inductor and switch devices. It also requires a bigger output capacitor for the same output voltage ripple requirement. A reasonable value is setting the ripple current to be 30% of the DC output current. Because the ripple current increases with the input voltage, the maximum input voltage is always used to determine the inductance. The DC resistance of the inductor is a key parameter for the efficiency. Lower DC resistance is available with a bigger winding area. A good tradeoff between the efficiency and the core size is letting the inductor copper loss equal 2% of the output power. See [Selecting Inductors for Buck Converters](#) for more information on selecting inductors. A good starting point for most applications is a 10 μH to 22 μH with 1.1 A or greater current rating for the LM2842 or a 0.7 A or greater current rating for the LM284x. Using such a rating enables the device to current limit without saturating the inductor. This is preferable to the device going into thermal shutdown mode and the possibility of damaging the inductor if the output is shorted to ground or other long-term overload.

Table 2. Recommended Inductors

MANUFACTURER	INDUCTOR	CONTACT INFORMATION
Coilcraft	LPS4018, DO1608C, DO3308, and LPO2506 series	www.coilcraft.com 800-3222645
MuRata	LQH55D and LQH66S series	www.murata.com
Coiltronics	MP2 and MP2A series	www.cooperbusman.com

8.2.2.4 Input Capacitor

A low ESR ceramic capacitor (C_{IN}) is needed between the V_{IN} pin and GND pin. This capacitor prevents large voltage transients from appearing at the input. Use a 2.2-μF to 10-μF value with X5R or X7R dielectric. Depending on construction, a ceramic capacitor's value can decrease up to 50% of its nominal value when rated voltage is applied. Consult with the capacitor manufacturer's data sheet for information on capacitor derating over voltage and temperature.

8.2.2.5 Output Capacitor

The selection of C_{OUT} is driven by the maximum allowable output voltage ripple. The output ripple in the constant frequency, PWM mode is approximated by Equation 6.

$$V_{RIPPLE} = I_{RIPPLE} (ESR + (1 / (8f_{SW}C_{OUT}))) \quad (6)$$

The ESR term usually plays the dominant role in determining the voltage ripple. Low-ESR ceramic capacitors are recommended. Capacitors in the range of 22 μ F to 100 μ F are a good starting point with an ESR of 0.1 Ω or less.

Table 3. Recommended Input and Output Capacitors

MANUFACTURER	CAPACITOR	CONTACT INFORMATION
Vishay Sprague	293D, 592D, and 595D series tantalum	www.vishay.com 407-324-4140
Taiyo Yuden	High capacitance MLCC ceramic	www.t-yuden.com 408-573-4150
Cornell Dubilier	ESRD series Polymer Aluminum Electrolytic SPV and AFK series V-chip series	www.cde.com
MuRata	High capacitance MLCC ceramic	www.murata.com

8.2.2.6 Bootstrap Capacitor

A 0.15- μ F ceramic capacitor or larger is recommended for the bootstrap capacitor (C_{BOOT}). For applications where the input voltage is less than twice the output voltage a larger capacitor is recommended, generally 0.15 μ F to 1 μ F to ensure plenty of gate drive for the internal switches and a consistently low $R_{DS(ON)}$.

8.2.2.7 Soft-Start Components

The devices have circuitry that is used in conjunction with the \overline{SHDN} pin to limit the inrush current on start-up of the DC/DC switching regulator. The \overline{SHDN} pin in conjunction with a RC filter is used to tailor the soft start for a specific application. When a voltage applied to the \overline{SHDN} pin is between 0 V and up to 2.3 V it causes the cycle-by-cycle current limit in the power stage to be modulated for minimum current limit at 0 V up to the rated current limit at 2.3 V. Thus controlling the output rise time and inrush current at start-up. The resistor value must be selected so the current injected into the \overline{SHDN} pin is greater than the leakage current of the \overline{SHDN} pin (1.5 μ A) when the voltage at \overline{SHDN} is equal or greater than 2.3 V.

8.2.2.8 Shutdown Operation

The \overline{SHDN} pin of the LM284x is designed so that it may be controlled using 2.3 V or higher logic signals. If the shutdown function is not to be used the \overline{SHDN} pin may be tied to V_{IN} . This input must not be allowed to float

The maximum voltage to the \overline{SHDN} pin should not exceed 42 V. If the use of a higher voltage is desired due to system or other constraints it may be used; however, a 100 k Ω or larger resistor is recommended between the applied voltage and the \overline{SHDN} pin to protect the device.

8.2.2.9 Schottky Diode

The breakdown voltage rating of the diode (D1) is preferred to be 25% higher than the maximum input voltage. The current rating for the diode must be equal to the maximum output current for best reliability in most applications. In cases where the duty cycle is greater than 50%, the average diode current is lower. In this case it is possible to use a diode with a lower average current rating, approximately $(1 - D)I_{OUT}$; however, the peak current rating should be higher than the maximum load current. A 0.5-A to 1-A rated diode is a good starting point.

8.2.3 Application Curves

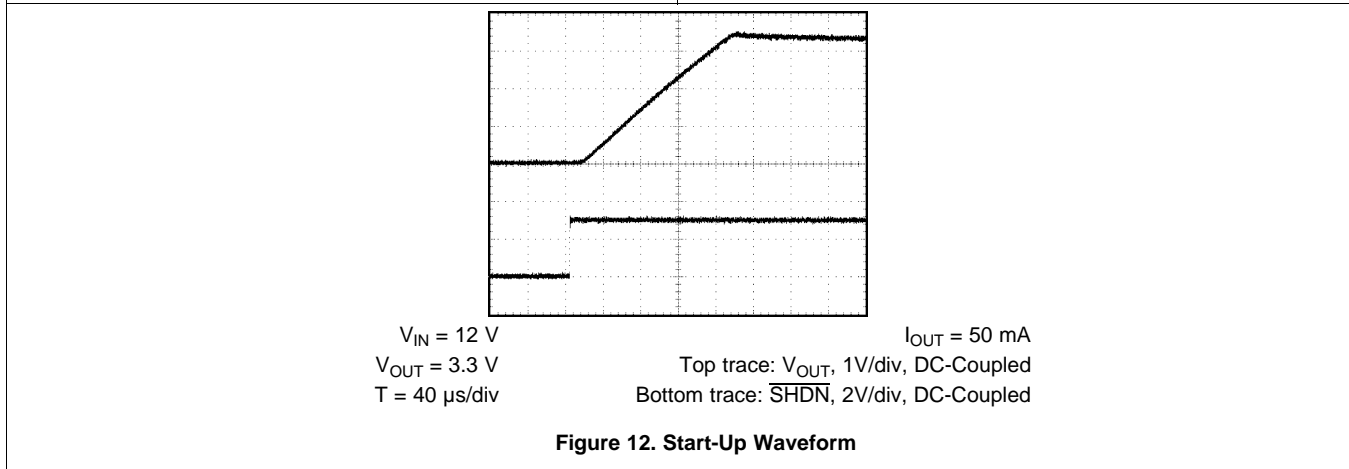
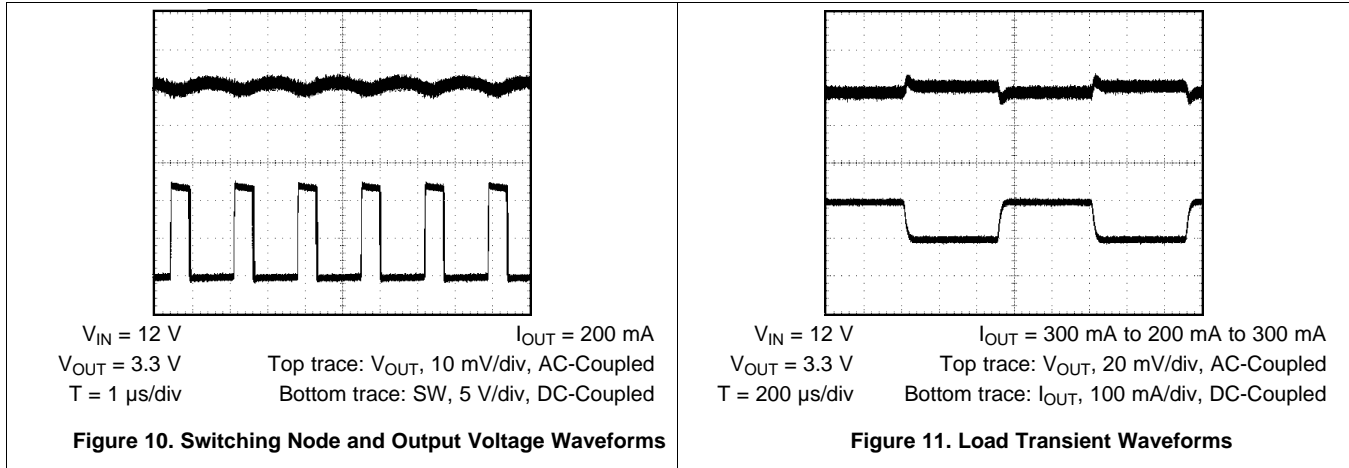

8.2.4 Other Application Circuits

Figure 13 to Figure 16 show application circuit examples using the LM284x devices. Customers must fully validate and test these circuits before implementing a design based on these examples. Unless otherwise noted, the design procedures in are applicable to these designs.

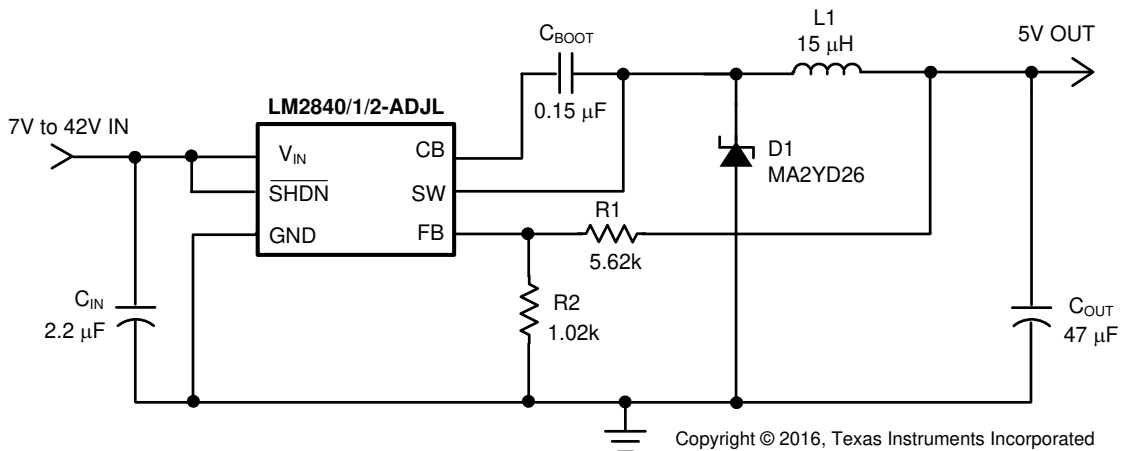

Figure 13. Step-Down Converter With 5-V Output Voltage

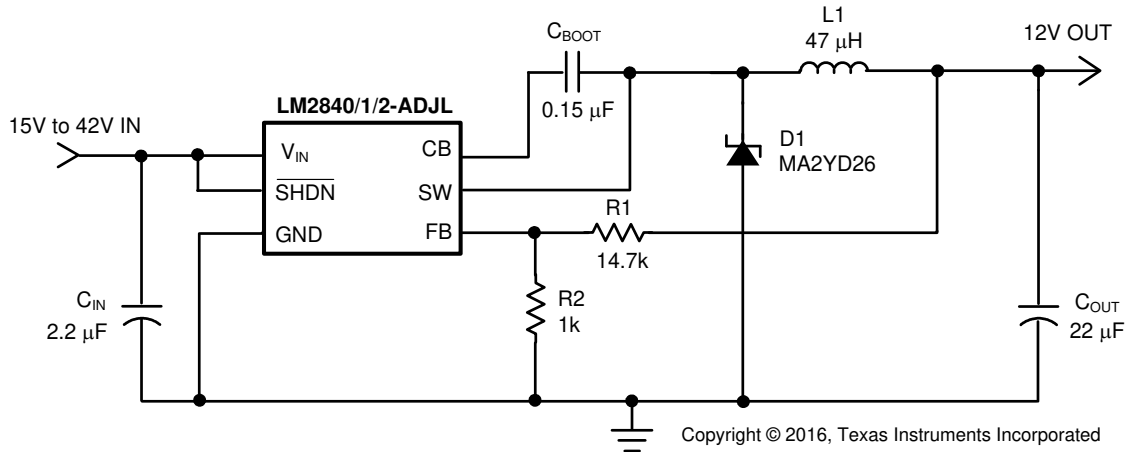

Figure 14. Step-Down Converter With 12-V Output Voltage

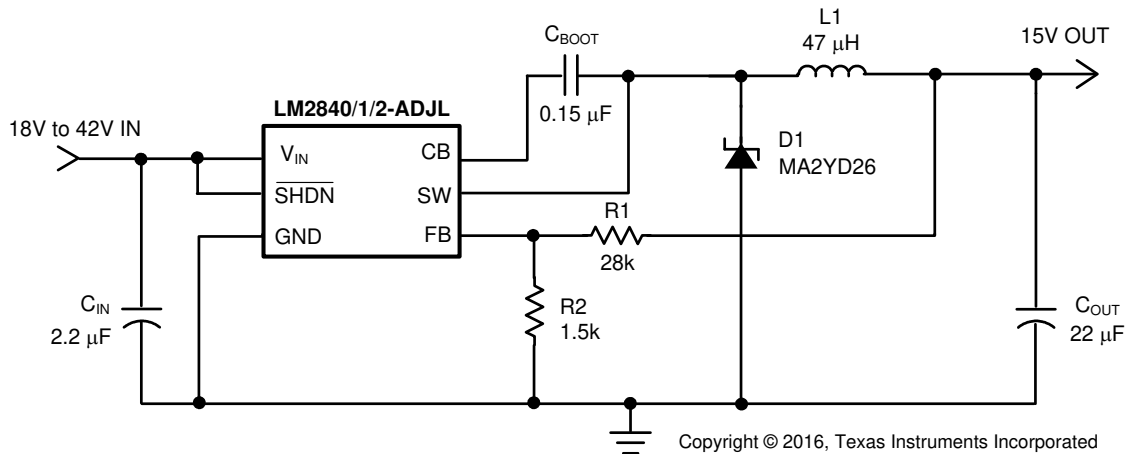

Figure 15. Step-Down Converter With 15-V Output Voltage

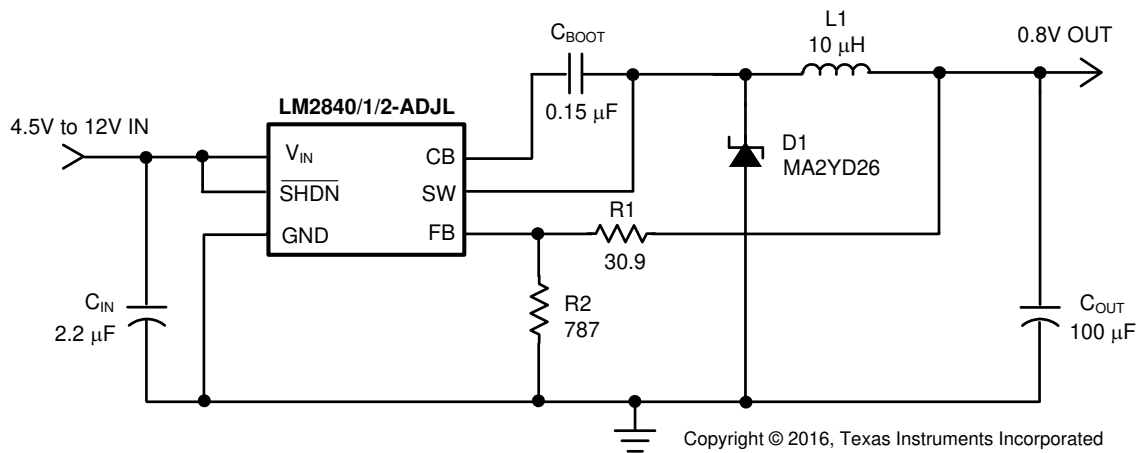

Figure 16. Step-Down Converter With 0.8-V Output Voltage

9 Power Supply Recommendations

The LM284x are designed to operate from an input voltage supply range between 4 V and 42 V. This input supply must be able to withstand the maximum input current and maintain a voltage above 4.5 V. The resistance of the input supply rail must be low enough that an input current transient does not cause a drop at the device supply voltage high enough to cause a false UVLO fault triggering and system reset. If the input supply is located more than a few inches from the device, additional bulk capacitance may be required in addition to the ceramic input capacitors.

10 Layout

10.1 Layout Guidelines

To reduce problems with conducted noise pickup, the ground side of the feedback network should be connected directly to the GND pin with its own connection. The feedback network, resistors R1 and R2, must be kept close to the FB pin, and away from the inductor to minimize coupling noise into the feedback pin. The input bypass capacitor C_{IN} must be placed close to the V_{IN} pin. This reduces copper trace resistance, which effects input voltage ripple of the IC. The inductor L1 must be placed close to the SW pin to reduce EMI and capacitive coupling. The output capacitor, C_{OUT} must be placed close to the junction of L1 and the diode D1. The L1, D1, and C_{OUT} trace must be as short as possible to reduce conducted and radiated noise and increase overall efficiency. The ground connection for the diode, C_{IN} , and C_{OUT} must be as small as possible and tied to the system ground plane in only one spot (preferably at the C_{OUT} ground point) to minimize conducted noise in the system ground plane. See [Layout Guidelines for Switching Power Supplies](#) for more detail on switching power supply layout considerations.

10.2 Layout Example

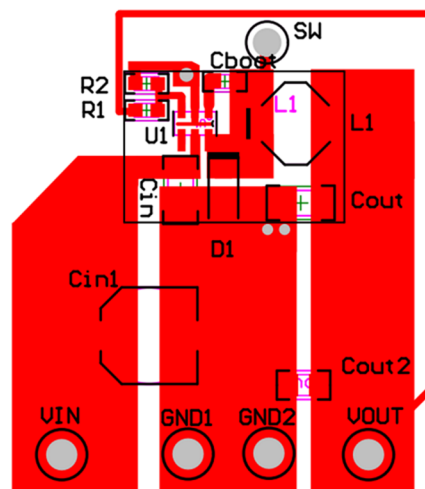

Figure 17. Recommended Layout

11 器件和文档支持

11.1 器件支持

11.1.1 第三方产品免责声明

TI 发布的与第三方产品或服务有关的信息，不能构成与此类产品或服务或保修的适用性有关的认可，不能构成此类产品或服务单独或与任何 TI 产品或服务一起的表示或认可。

11.1.2 开发支持

11.1.2.1 使用 **WEBENCH®** 工具创建定制设计

请单击[此处](#)，使用 LM2840 器件并借助 WEBENCH® 电源设计器创建定制设计方案。

1. 首先输入输入电压 (V_{IN})、输出电压 (V_{OUT}) 和输出电流 (I_{OUT}) 要求。
2. 使用优化器拨盘优化该设计的关键参数，如效率、尺寸和成本。
3. 将生成的设计与德州仪器 (TI) 的其他可行的解决方案进行比较。

WEBENCH 电源设计器可提供定制原理图以及罗列实时价格和组件供货情况的物料清单。

在多数情况下，可执行以下操作：

- 运行电气仿真，观察重要波形以及电路性能
- 运行热性能仿真，了解电路板热性能
- 将定制原理图和布局方案以常用 CAD 格式导出
- 打印设计方案的 PDF 报告并与同事共享

有关 WEBENCH 工具的详细信息，请访问 www.ti.com.cn/WEBENCH。

11.2 文档支持

11.2.1 相关文档

请参阅如下相关文档：

- 《[AN-1197 选择适用于降压转换器的电感器](#)》(SNVA038)
- 《[AN-1149 开关电源布局指南](#)》(SNVA021)

11.3 相关链接

下表列出了快速访问链接。类别包括技术文档、支持和社区资源、工具和软件，以及立即订购快速访问。

表 4. 相关链接

器件	产品文件夹	立即订购	技术文档	工具与软件	支持和社区
LM2840	请单击此处	请单击此处	请单击此处	请单击此处	请单击此处
LM2841	请单击此处	请单击此处	请单击此处	请单击此处	请单击此处
LM2842	请单击此处	请单击此处	请单击此处	请单击此处	请单击此处

11.4 接收文档更新通知

如需接收文档更新通知，请导航至 TI.com.cn 上的器件产品文件夹。单击右上角的[通知我](#)进行注册，即可每周接收产品信息更改摘要。有关更改的详细信息，请查看任何已修订文档中包含的修订历史记录。

11.5 社区资源

The following links connect to TI community resources. Linked contents are provided "AS IS" by the respective contributors. They do not constitute TI specifications and do not necessarily reflect TI's views; see TI's [Terms of Use](#).

TI E2E™ Online Community *TI's Engineer-to-Engineer (E2E) Community*. Created to foster collaboration among engineers. At e2e.ti.com, you can ask questions, share knowledge, explore ideas and help solve problems with fellow engineers.

社区资源 (接下页)

Design Support *TI's Design Support* Quickly find helpful E2E forums along with design support tools and contact information for technical support.

11.6 商标

SIMPLE SWITCHER, E2E are trademarks of Texas Instruments.
WEBENCH, SIMPLE SWITCHER are registered trademarks of Texas Instruments.
All other trademarks are the property of their respective owners.

11.7 静电放电警告



这些装置包含有限的内置 ESD 保护。存储或装卸时，应将导线一起截短或将装置放置于导电泡棉中，以防止 MOS 门极遭受静电损伤。

11.8 Glossary

SLYZ022 — *TI Glossary*.

This glossary lists and explains terms, acronyms, and definitions.

12 机械、封装和可订购信息

以下页面包含机械、封装和可订购信息。这些信息是指定器件的最新可用数据。数据如有变更，恕不另行通知，且不会对此文档进行修订。如需获取此数据表的浏览器版本，请查阅左侧的导航栏。

PACKAGING INFORMATION

Orderable part number	Status (1)	Material type (2)	Package Pins	Package qty Carrier	RoHS (3)	Lead finish/ Ball material (4)	MSL rating/ Peak reflow (5)	Op temp (°C)	Part marking (6)
LM2840XMK-ADJL/NO.A	Active	Production	SOT-23-THIN (DDC) 6	1000 SMALL T&R	Yes	SN	Level-1-260C-UNLIM	-40 to 125	SE8B
LM2840XMK-ADJL/NOPB	Active	Production	SOT-23-THIN (DDC) 6	1000 SMALL T&R	Yes	SN	Level-1-260C-UNLIM	-40 to 125	SE8B
LM2840XMKX-ADJL/NO.A	Active	Production	SOT-23-THIN (DDC) 6	3000 LARGE T&R	Yes	SN	Level-1-260C-UNLIM	-40 to 125	SE8B
LM2840XMKX-ADJL/NOPB	Active	Production	SOT-23-THIN (DDC) 6	3000 LARGE T&R	Yes	SN	Level-1-260C-UNLIM	-40 to 125	SE8B
LM2840YMK-ADJL/NO.A	Active	Production	SOT-23-THIN (DDC) 6	1000 SMALL T&R	Yes	SN	Level-1-260C-UNLIM	-40 to 125	SF1B
LM2840YMK-ADJL/NOPB	Active	Production	SOT-23-THIN (DDC) 6	1000 SMALL T&R	Yes	SN	Level-1-260C-UNLIM	-40 to 125	SF1B
LM2841XMK-ADJL/NO.A	Active	Production	SOT-23-THIN (DDC) 6	1000 SMALL T&R	Yes	SN	Level-1-260C-UNLIM	-40 to 125	STFB
LM2841XMK-ADJL/NOPB	Active	Production	SOT-23-THIN (DDC) 6	1000 SMALL T&R	Yes	SN	Level-1-260C-UNLIM	-40 to 125	STFB
LM2841XMKX-ADJL/NO.A	Active	Production	SOT-23-THIN (DDC) 6	3000 LARGE T&R	Yes	SN	Level-1-260C-UNLIM	-40 to 125	STFB
LM2841XMKX-ADJL/NOPB	Active	Production	SOT-23-THIN (DDC) 6	3000 LARGE T&R	Yes	SN	Level-1-260C-UNLIM	-40 to 125	STFB
LM2841YMK-ADJL/NO.A	Active	Production	SOT-23-THIN (DDC) 6	1000 SMALL T&R	Yes	SN	Level-1-260C-UNLIM	-40 to 125	STTB
LM2841YMK-ADJL/NOPB	Active	Production	SOT-23-THIN (DDC) 6	1000 SMALL T&R	Yes	SN	Level-1-260C-UNLIM	-40 to 125	STTB
LM2841YMKX-ADJL/NO.A	Active	Production	SOT-23-THIN (DDC) 6	3000 LARGE T&R	Yes	SN	Level-1-260C-UNLIM	-40 to 125	STTB
LM2841YMKX-ADJL/NOPB	Active	Production	SOT-23-THIN (DDC) 6	3000 LARGE T&R	Yes	SN	Level-1-260C-UNLIM	-40 to 125	STTB
LM2842XMK-ADJL/NO.A	Active	Production	SOT-23-THIN (DDC) 6	1000 SMALL T&R	Yes	SN	Level-1-260C-UNLIM	-40 to 125	STVB
LM2842XMK-ADJL/NOPB	Active	Production	SOT-23-THIN (DDC) 6	1000 SMALL T&R	Yes	SN	Level-1-260C-UNLIM	-40 to 125	STVB

Orderable part number	Status (1)	Material type (2)	Package Pins	Package qty Carrier	RoHS (3)	Lead finish/ Ball material (4)	MSL rating/ Peak reflow (5)	Op temp (°C)	Part marking (6)
LM2842XMKX-ADJL/NO.A	Active	Production	SOT-23-THIN (DDC) 6	3000 LARGE T&R	Yes	SN	Level-1-260C-UNLIM	-40 to 125	STVB
LM2842XMKX-ADJL/NOPB	Active	Production	SOT-23-THIN (DDC) 6	3000 LARGE T&R	Yes	SN	Level-1-260C-UNLIM	-40 to 125	STVB
LM2842YMK-ADJL/NO.A	Active	Production	SOT-23-THIN (DDC) 6	1000 SMALL T&R	Yes	SN	Level-1-260C-UNLIM	-40 to 125	STXB
LM2842YMK-ADJL/NOPB	Active	Production	SOT-23-THIN (DDC) 6	1000 SMALL T&R	Yes	SN	Level-1-260C-UNLIM	-40 to 125	STXB
LM2842YMKX-ADJL/NO.A	Active	Production	SOT-23-THIN (DDC) 6	3000 LARGE T&R	Yes	SN	Level-1-260C-UNLIM	-40 to 125	STXB
LM2842YMKX-ADJL/NOPB	Active	Production	SOT-23-THIN (DDC) 6	3000 LARGE T&R	Yes	SN	Level-1-260C-UNLIM	-40 to 125	STXB

(1) **Status:** For more details on status, see our [product life cycle](#).

(2) **Material type:** When designated, preproduction parts are prototypes/experimental devices, and are not yet approved or released for full production. Testing and final process, including without limitation quality assurance, reliability performance testing, and/or process qualification, may not yet be complete, and this item is subject to further changes or possible discontinuation. If available for ordering, purchases will be subject to an additional waiver at checkout, and are intended for early internal evaluation purposes only. These items are sold without warranties of any kind.

(3) **RoHS values:** Yes, No, RoHS Exempt. See the [TI RoHS Statement](#) for additional information and value definition.

(4) **Lead finish/Ball material:** Parts may have multiple material finish options. Finish options are separated by a vertical ruled line. Lead finish/Ball material values may wrap to two lines if the finish value exceeds the maximum column width.

(5) **MSL rating/Peak reflow:** The moisture sensitivity level ratings and peak solder (reflow) temperatures. In the event that a part has multiple moisture sensitivity ratings, only the lowest level per JEDEC standards is shown. Refer to the shipping label for the actual reflow temperature that will be used to mount the part to the printed circuit board.

(6) **Part marking:** There may be an additional marking, which relates to the logo, the lot trace code information, or the environmental category of the part.

Multiple part markings will be inside parentheses. Only one part marking contained in parentheses and separated by a "-" will appear on a part. If a line is indented then it is a continuation of the previous line and the two combined represent the entire part marking for that device.

Important Information and Disclaimer: The information provided on this page represents TI's knowledge and belief as of the date that it is provided. TI bases its knowledge and belief on information provided by third parties, and makes no representation or warranty as to the accuracy of such information. Efforts are underway to better integrate information from third parties. TI has taken and continues to take reasonable steps to provide representative

and accurate information but may not have conducted destructive testing or chemical analysis on incoming materials and chemicals. TI and TI suppliers consider certain information to be proprietary, and thus CAS numbers and other limited information may not be available for release.

In no event shall TI's liability arising out of such information exceed the total purchase price of the TI part(s) at issue in this document sold by TI to Customer on an annual basis.

OTHER QUALIFIED VERSIONS OF LM2840, LM2841, LM2842 :

- Automotive : [LM2840-Q1](#), [LM2841-Q1](#), [LM2842-Q1](#)

NOTE: Qualified Version Definitions:

- Automotive - Q100 devices qualified for high-reliability automotive applications targeting zero defects

TAPE AND REEL INFORMATION

QUADRANT ASSIGNMENTS FOR PIN 1 ORIENTATION IN TAPE

*All dimensions are nominal

Device	Package Type	Package Drawing	Pins	SPQ	Reel Diameter (mm)	Reel Width W1 (mm)	A0 (mm)	B0 (mm)	K0 (mm)	P1 (mm)	W (mm)	Pin1 Quadrant
LM2840XMK-ADJL/NOPB	SOT-23-THIN	DDC	6	1000	178.0	8.4	3.2	3.2	1.4	4.0	8.0	Q3
LM2840XMKX-ADJL/NOPB	SOT-23-THIN	DDC	6	3000	178.0	8.4	3.2	3.2	1.4	4.0	8.0	Q3
LM2840YMK-ADJL/NOPB	SOT-23-THIN	DDC	6	1000	178.0	8.4	3.2	3.2	1.4	4.0	8.0	Q3
LM2841XMK-ADJL/NOPB	SOT-23-THIN	DDC	6	1000	178.0	8.4	3.2	3.2	1.4	4.0	8.0	Q3
LM2841XMKX-ADJL/NOPB	SOT-23-THIN	DDC	6	3000	178.0	8.4	3.2	3.2	1.4	4.0	8.0	Q3
LM2841YMK-ADJL/NOPB	SOT-23-THIN	DDC	6	1000	178.0	8.4	3.2	3.2	1.4	4.0	8.0	Q3
LM2841YMKX-ADJL/NOPB	SOT-23-THIN	DDC	6	3000	178.0	8.4	3.2	3.2	1.4	4.0	8.0	Q3
LM2842XMK-ADJL/NOPB	SOT-23-THIN	DDC	6	1000	178.0	8.4	3.2	3.2	1.4	4.0	8.0	Q3
LM2842XMKX-ADJL/NOPB	SOT-23-THIN	DDC	6	3000	178.0	8.4	3.2	3.2	1.4	4.0	8.0	Q3

Device	Package Type	Package Drawing	Pins	SPQ	Reel Diameter (mm)	Reel Width W1 (mm)	A0 (mm)	B0 (mm)	K0 (mm)	P1 (mm)	W (mm)	Pin1 Quadrant
LM2842YMK-ADJL/NOPB	SOT-23-THIN	DDC	6	1000	178.0	8.4	3.2	3.2	1.4	4.0	8.0	Q3
LM2842YMKX-ADJL/NOPB	SOT-23-THIN	DDC	6	3000	178.0	8.4	3.2	3.2	1.4	4.0	8.0	Q3

TAPE AND REEL BOX DIMENSIONS

*All dimensions are nominal

Device	Package Type	Package Drawing	Pins	SPQ	Length (mm)	Width (mm)	Height (mm)
LM2840XMK-ADJL/NOPB	SOT-23-THIN	DDC	6	1000	210.0	185.0	35.0
LM2840XMKX-ADJL/NOPB	SOT-23-THIN	DDC	6	3000	210.0	185.0	35.0
LM2840YMK-ADJL/NOPB	SOT-23-THIN	DDC	6	1000	210.0	185.0	35.0
LM2841XMK-ADJL/NOPB	SOT-23-THIN	DDC	6	1000	210.0	185.0	35.0
LM2841XMKX-ADJL/NOPB	SOT-23-THIN	DDC	6	3000	210.0	185.0	35.0
LM2841YMK-ADJL/NOPB	SOT-23-THIN	DDC	6	1000	210.0	185.0	35.0
LM2841YMKX-ADJL/NOPB	SOT-23-THIN	DDC	6	3000	208.0	191.0	35.0
LM2842XMK-ADJL/NOPB	SOT-23-THIN	DDC	6	1000	208.0	191.0	35.0
LM2842XMKX-ADJL/NOPB	SOT-23-THIN	DDC	6	3000	208.0	191.0	35.0
LM2842YMK-ADJL/NOPB	SOT-23-THIN	DDC	6	1000	208.0	191.0	35.0
LM2842YMKX-ADJL/NOPB	SOT-23-THIN	DDC	6	3000	208.0	191.0	35.0

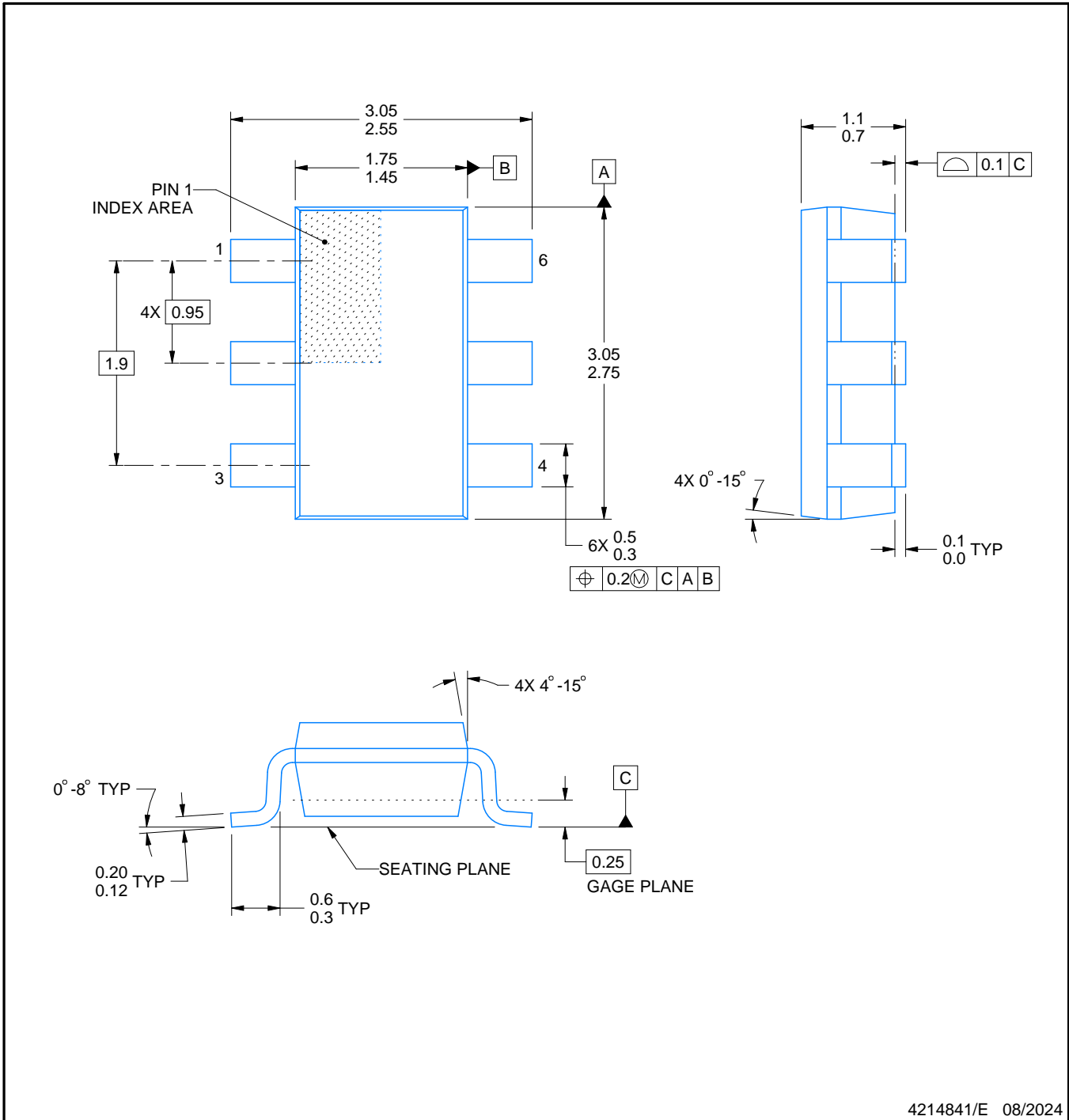

4214841/E 08/2024

NOTES:

1. All linear dimensions are in millimeters. Any dimensions in parenthesis are for reference only. Dimensioning and tolerancing per ASME Y14.5M.
2. This drawing is subject to change without notice.
3. Reference JEDEC MO-193.

EXAMPLE BOARD LAYOUT

DDC0006A

SOT-23 - 1.1 max height

SMALL OUTLINE TRANSISTOR

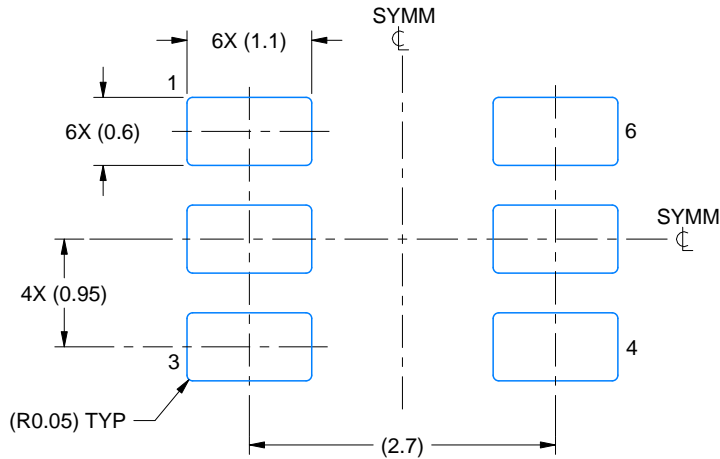

LAND PATTERN EXAMPLE
EXPLODED METAL SHOWN
SCALE:15X

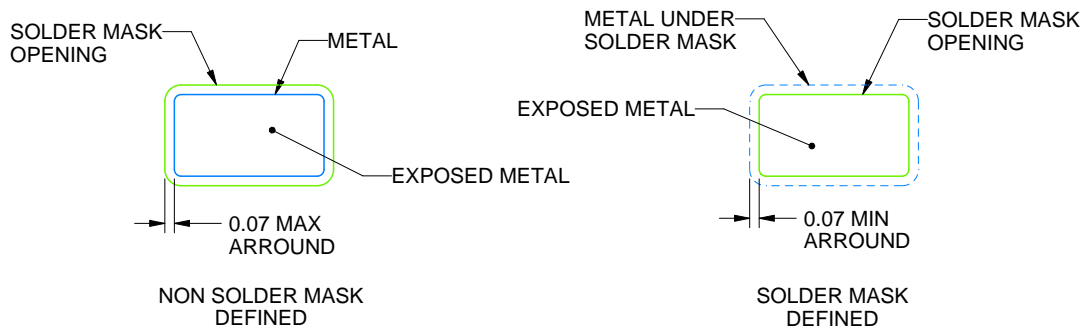

SOLDEMASK DETAILS

4214841/E 08/2024

NOTES: (continued)

4. Publication IPC-7351 may have alternate designs.
5. Solder mask tolerances between and around signal pads can vary based on board fabrication site.

EXAMPLE STENCIL DESIGN

DDC0006A

SOT-23 - 1.1 max height

SMALL OUTLINE TRANSISTOR

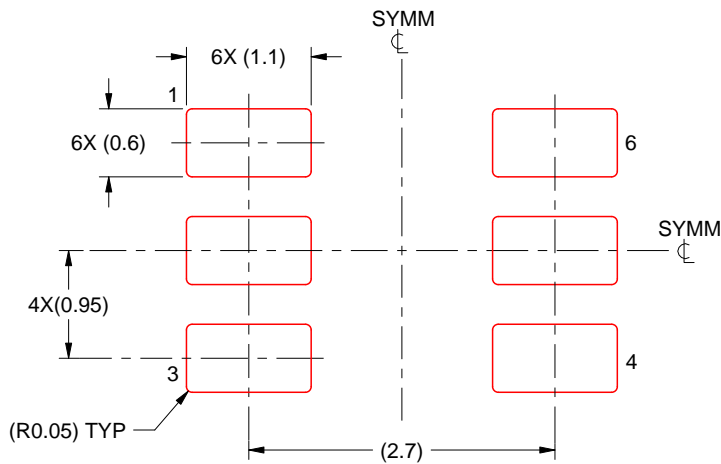

SOLDER PASTE EXAMPLE
BASED ON 0.125 THICK STENCIL
SCALE:15X

4214841/E 08/2024

NOTES: (continued)

6. Laser cutting apertures with trapezoidal walls and rounded corners may offer better paste release. IPC-7525 may have alternate design recommendations.
7. Board assembly site may have different recommendations for stencil design.

重要通知和免责声明

TI“按原样”提供技术和可靠性数据（包括数据表）、设计资源（包括参考设计）、应用或其他设计建议、网络工具、安全信息和其他资源，不保证没有瑕疵且不做出任何明示或暗示的担保，包括但不限于对适销性、与某特定用途的适用性或不侵犯任何第三方知识产权的暗示担保。

这些资源可供使用 TI 产品进行设计的熟练开发人员使用。您将自行承担以下全部责任：(1) 针对您的应用选择合适的 TI 产品，(2) 设计、验证并测试您的应用，(3) 确保您的应用满足相应标准以及任何其他安全、安保法规或其他要求。

这些资源如有变更，恕不另行通知。TI 授权您仅可将这些资源用于研发本资源所述的 TI 产品的相关应用。严禁以其他方式对这些资源进行复制或展示。您无权使用任何其他 TI 知识产权或任何第三方知识产权。对于因您对这些资源的使用而对 TI 及其代表造成的任何索赔、损害、成本、损失和债务，您将全额赔偿，TI 对此概不负责。

TI 提供的产品受 [TI 销售条款](#)、[TI 通用质量指南](#) 或 [ti.com](#) 上其他适用条款或 TI 产品随附的其他适用条款的约束。TI 提供这些资源并不会扩展或以其他方式更改 TI 针对 TI 产品发布的适用的担保或担保免责声明。除非德州仪器 (TI) 明确将某产品指定为定制产品或客户特定产品，否则其产品均为按确定价格收入目录的标准通用器件。

TI 反对并拒绝您可能提出的任何其他或不同的条款。

版权所有 © 2025，德州仪器 (TI) 公司

最后更新日期：2025 年 10 月