

## INA20x -16-V 至 80-V、500-kHz 电流感测放大器，带双比较器

### 1 特性

- 完整的电流检测解决方案
- 有三种增益可供选择：
  - INA203 = 20V/V
  - INA204 = 50V/V
  - INA205 = 100V/V
- 两个比较器：
  - 具有锁存功能的比较器 1
  - 带可选延迟的比较器 2
- 共模范围：-16V 至 80V
- 高精度：过温条件下为 3.5% (最大值)
- 带宽：500kHz
- 静态电流：1.8mA
- 封装：SO-14、TSSOP-14、VSSOP-10

### 2 应用

- 笔记本电脑
- 手机
- 电信设备
- 汽车
- 电源管理
- 电池充电器
- 焊接设备

### 3 说明

INA203、INA204 和 INA205 是一系列单向电流分流监控器，具有电压输出、两个比较器和电压基准。INA203、INA204 和 INA205 能够在 -16V 至 80V 范围内的共模电压下检测分流器两端的压降。INA203、INA204 和 INA205 可提供三种输出电压级别：20V/V、50V/V 和 100V/V，带宽高达 500kHz。

INA203、INA204 和 INA205 还整合了两个带 0.6V 内部基准的开漏比较器。14 引脚版本的比较器基准可用外部输入覆盖。比较器 1 具有锁存功能，而比较器 2 的延迟可由用户通过编程设定。此外，14 引脚版本还提供 1.2V 基准输出。

INA203、INA204 和 INA205 由 2.7V 至 18V 单电源供电。它们的额定工作温度范围为 -40°C 至 125°C。

#### 器件信息(1)

器件型号	封装	封装尺寸 (标称值)
INA203、 INA204、 INA205	SOIC (14)	8.65mm × 3.91mm
	VSSOP (10)	3.00mm × 3.00mm
	TSSOP (14)	5.00mm × 4.40mm

(1) 如需了解所有可用封装，请参阅数据表末尾的可订购产品附录。

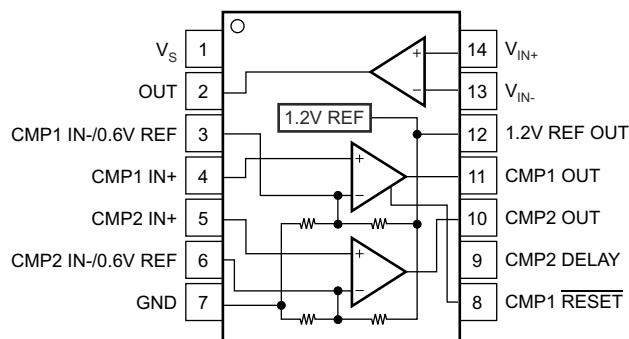

简化版原理图

## Table of Contents

<b>1 特性</b> .....	1	7.3 Feature Description.....	14
<b>2 应用</b> .....	1	7.4 Device Functional Modes.....	18
<b>3 说明</b> .....	1	<b>8 Application and Implementation</b> .....	22
<b>4 Revision History</b> .....	2	8.1 Application Information.....	22
<b>5 Pin Configuration and Functions</b> .....	4	8.2 Typical Application.....	22
<b>6 Specifications</b> .....	5	<b>9 Power Supply Recommendations</b> .....	23
6.1 Absolute Maximum Ratings.....	5	<b>10 Layout</b> .....	24
6.2 ESD Ratings.....	5	10.1 Layout Guidelines.....	24
6.3 Recommended Operating Conditions.....	5	10.2 Layout Example.....	24
6.4 Thermal Information.....	5	<b>11 Device and Documentation Support</b> .....	25
6.5 Electrical Characteristics: Current-Shunt Monitor.....	6	11.1 Related Links.....	25
6.6 Electrical Characteristics: Comparator.....	7	11.2 接收文档更新通知.....	25
6.7 Electrical Characteristics: Reference.....	9	11.3 支持资源.....	25
6.8 Electrical Characteristics: General.....	9	11.4 Trademarks.....	25
6.9 Typical Characteristics.....	10	11.5 Electrostatic Discharge Caution.....	25
<b>7 Detailed Description</b> .....	14	11.6 术语表.....	25
7.1 Overview.....	14	<b>12 Mechanical, Packaging, and Orderable Information</b> .....	25
7.2 Functional Block Diagrams.....	14		

## 4 Revision History

注：以前版本的页码可能与当前版本的页码不同

<b>Changes from Revision E (November 2015) to Revision F (June 2021)</b>	<b>Page</b>
• 更新了整个文档中的表格、图和交叉参考的编号格式.....	1
• Changed maximum input voltage for accurate measurements from: $(V_{SHUNT} - 0.25) / \text{Gain}$ to: $(V_{OUT} - 0.25) / \text{Gain}$ .....	15

---

<b>Changes from Revision D (May 2009) to Revision E (November 2015)</b>	<b>Page</b>
• 添加了 ESD 等级表、特性说明部分、器件功能模式、应用和实施部分、电源相关建议部分、布局部分、器件和文档支持部分以及机械、封装和可订购信息部分.....	1
• Moved thermal values from <i>Electrical Characteristics: General</i> to <i>Thermal Information</i> table. Removed duplicate storage temperature parameter.....	9

---

<b>Changes from Revision C (October 2007) to Revision D (May 2009)</b>	<b>Page</b>
• Changed 图 6-1 .....	7

## Device Comparison

表 5-1. Device Gain

DEVICE	GAIN
INA203	20 V/V
INA204	50 V/V
INA205	100 V/V

表 5-2. Related Products

FEATURES	PRODUCT
Variant of INA203 - INA205 Comparator 2 polarity	<a href="#">INA206 - INA208</a>
Current-shunt monitor with single Comparator and $V_{REF}$	<a href="#">INA200 - INA202</a>
Current-shunt monitor only	<a href="#">INA193 - INA198</a>
Current-shunt monitor with split stages for filter options	<a href="#">INA270 - INA271</a>

## 5 Pin Configuration and Functions



图 5-1. D and PW Packages 14-Pin SOIC and TSSOP Top View



图 5-2. DGS Package 10-Pin VSSOP Top View

表 5-1. Pin Functions

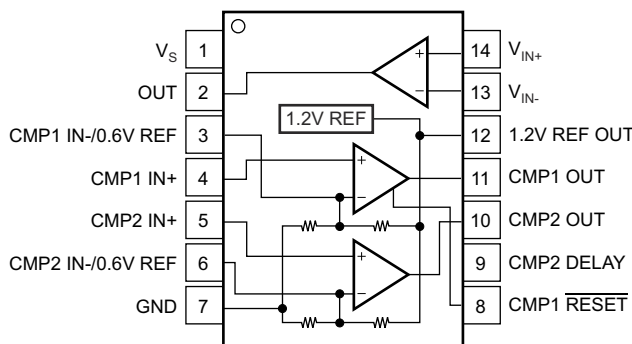
NAME	PIN		I/O	DESCRIPTION
	SOIC, TSSOP	VSSOP		
V <sub>S</sub>	1	1	I	Power Supply
OUT	2	2	O	Output voltage
CMP1 IN-/0.6-V Ref	3	—	I	Comparator 1 negative input, can be used to override the internal 0.6-V reference
CMP1 IN+	4	3	I	Comparator 1 positive input
CMP2 IN+	5	—	I	Comparator 2 positive input
CMP2 IN -	—	4	I	Comparator 2 negative input
CMP2 IN - /0.6-V Ref	6	—	I	Comparator 2 negative input, can be used to override the internal 0.6-V reference
GND	7	5	I	Ground
CMP1 RESET	8	6	I	Comparator 1 output reset, active low
CMP2 DELAY	9	—	I	Connect an optional capacitor to adjust comparator 2 delay
CMP2 OUT	10	7	O	Comparator 2 output
CMP1 OUT	11	8	O	Comparator 1 output
1.2-V REF OUT	12	—	O	1.2-V reference output
V <sub>IN</sub> -	13	9	I	Connect to shunt low side
V <sub>IN</sub> +	14	10	I	Connect to shunt high side

## 6 Specifications

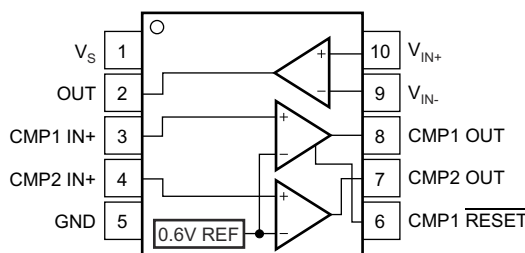
### 6.1 Absolute Maximum Ratings

See (1)

		MIN	MAX	UNIT
Supply Voltage, $V_S$			18	V
Current-Shunt Monitor Analog Inputs, $V_{IN+}$ and $V_{IN-}$	Differential ( $V_{IN+} - V_{IN-}$ )	- 18	18	V
	Common-Mode	- 16	80	V
Comparator Analog Input and Reset Pins		GND - 0.3	$(V_S) + 0.3$	V
Analog Output, Out Pin		GND - 0.3	$(V_S) + 0.3$	V
Comparator Output, Out Pin		GND - 0.3	18	V
$V_{REF}$ and CMP2 Delay Pin		GND - 0.3	10	V
Input Current Into Any Pin			5	mA
Operating Temperature		- 55	150	°C
Junction Temperature		- 65	150	°C
Storage temperature, $T_{stg}$		- 65	150	°C

- (1) Stresses beyond those listed under *Absolute Maximum Ratings* may cause permanent damage to the device. These are stress ratings only, which do not imply functional operation of the device at these or any other conditions beyond those indicated under *Recommended Operating Conditions*. Exposure to absolute-maximum-rated conditions for extended periods may affect device reliability.

### 6.2 ESD Ratings

		VALUE	UNIT
$V_{(ESD)}$ Electrostatic discharge	Human body model (HBM), per ANSI/ESDA/JEDEC JS-001, all pins (1)	±4000	V
	Charged device model (CDM), per JEDEC specification JESD22-C101, all pins (2)	±500	

- (1) JEDEC document JEP155 states that 500-V HBM allows safe manufacturing with a standard ESD control process.  
(2) JEDEC document JEP157 states that 250-V CDM allows safe manufacturing with a standard ESD control process.

### 6.3 Recommended Operating Conditions

over operating free-air temperature range (unless otherwise noted)

		MIN	NOM	MAX	UNIT
$V_{CM}$	Common-mode input voltage	- 16	12	80	V
$V_S$	Operating supply voltage	2.7	12	18	V
$T_A$	Operating free-air temperature	- 40	25	125	°C

### 6.4 Thermal Information

THERMAL METRIC (1)		INA20x			UNIT
		D (SOIC)	DGS (VSSOP)	PW (TSSOP)	
		14 PINS	10 PINS	14 PINS	
$R_{\theta JA}$	Junction-to-ambient thermal resistance	84.9	161.3	112.6	°C/W
$R_{\theta JC(top)}$	Junction-to-case (top) thermal resistance	44	36.8	37.2	°C/W
$R_{\theta JB}$	Junction-to-board thermal resistance	39.4	82.3	55.4	°C/W
$\psi_{JT}$	Junction-to-top characterization parameter	10.3	1.3	2.7	°C/W
$\psi_{JB}$	Junction-to-board characterization parameter	39.1	80.8	54.7	°C/W
$R_{\theta JC(bot)}$	Junction-to-case (bottom) thermal resistance	150	200	150	°C/W

- (1) For more information about traditional and new thermal metrics, see the *Semiconductor and IC Package Thermal Metrics* application report, [SPRA953](#).

## 6.5 Electrical Characteristics: Current-Shunt Monitor

At  $T_A = 25^\circ\text{C}$ ,  $V_S = 12\text{ V}$ ,  $V_{CM} = 12\text{ V}$ ,  $V_{SENSE} = 100\text{ mV}$ ,  $R_L = 10\text{ k}\Omega$  to GND,  $R_{pullup} = 5.1\text{ k}\Omega$  each connected from CMP1 OUT and CMP2 OUT to  $V_S$ , and CMP1 IN+ = 1 V and CMP2 IN- = GND, unless otherwise noted.

PARAMETER		TEST CONDITIONS		MIN	TYP	MAX	UNIT
<b>INPUT</b>							
$V_{SENSE}$	Full-Scale Sense Input Voltage	$V_{SENSE} = V_{IN+} - V_{IN-}$			0.15	$(V_S - 0.25)/\text{Gain}$	V
$V_{CM}$	Common-Mode Input Range	$T_A = -40^\circ\text{C}$ to $125^\circ\text{C}$		-16		80	V
CMRR	Common-Mode Rejection Ratio	$V_{CM} = -16\text{ V}$ to $80\text{ V}$		80	100		dB
	CMRR over Temperature	$V_{CM} = 12\text{ V}$ to $80\text{ V}$	$T_A = -40^\circ\text{C}$ to $125^\circ\text{C}$	100	123		dB
$V_{OS}$	Offset Voltage, RTI <sup>(1)</sup>				$\pm 0.5$	$\pm 2.5$	mV
		25°C to 125°C				$\pm 3$	mV
		-40°C to 25°C				$\pm 3.5$	mV
d $V_{OS}/dT$	Offset Voltage, RTI <sup>(1)</sup> vs. Temperature	$T_{MIN}$ to $T_{MAX}$	$T_A = -40^\circ\text{C}$ to $125^\circ\text{C}$		5		$\mu\text{ V}/^\circ\text{C}$
PSR	Offset Voltage, RTI <sup>(1)</sup> vs. Power Supply	$V_{OUT} = 2\text{ V}$ , $V_{CM} = 18\text{ V}$ , $2.7\text{ V}$	$T_A = -40^\circ\text{C}$ to $125^\circ\text{C}$		2.5	100	$\mu\text{ V}/\text{V}$
$I_B$	Input Bias Current, $V_{IN-}$ Pin	$T_A = -40^\circ\text{C}$ to $125^\circ\text{C}$			$\pm 9$	$\pm 16$	$\mu\text{ A}$
<b>OUTPUT (<math>V_{SENSE} \geq 20\text{ mV}</math>)</b>							
G	Gain	INA203			20		V/V
		INA204			50		V/V
		INA205			100		V/V
	Gain Error	$V_{SENSE} = 20\text{ mV}$ to $100\text{ mV}$			$\pm 0.2\%$	$\pm 1\%$	
	Gain Error over Temperature	$V_{SENSE} = 20\text{ mV}$ to $100\text{ mV}$	$T_A = -40^\circ\text{C}$ to $125^\circ\text{C}$			$\pm 2\%$	
	Total Output Error <sup>(2)</sup>	$V_{SENSE} = 120\text{ mV}$ , $V_S = 16\text{ V}$			$\pm 0.75\%$	$\pm 2.2\%$	
	Total Output Error <sup>(2)</sup> over Temperature	$V_{SENSE} = 120\text{ mV}$ , $V_S = 16\text{ V}$	$T_A = -40^\circ\text{C}$ to $125^\circ\text{C}$			$\pm 3.5\%$	
	Nonlinearity Error <sup>(3)</sup>	$V_{SENSE} = 20\text{ mV}$ to $100\text{ mV}$			$\pm 0.002\%$		
$R_O$	Output Impedance, Pin 2				1.5		$\Omega$
	Maximum Capacitive Load	No Sustained Oscillation			10		nF
<b>OUTPUT (<math>V_{SENSE} &lt; 20\text{ mV}</math>) <sup>(4)</sup></b>							
	INA203, INA204, INA205 output	$-16\text{ V} \leq V_{CM} < 0\text{ V}$			300		mV
	INA203 output	$0\text{ V} \leq V_{CM} \leq V_S$ , $V_S = 5\text{ V}$				0.4	V
	INA204 output	$0\text{ V} \leq V_{CM} \leq V_S$ , $V_S = 5\text{ V}$				1	V
	INA205 output	$0\text{ V} \leq V_{CM} \leq V_S$ , $V_S = 5\text{ V}$				2	V
	INA203, INA204, INA205 output	$V_S < V_{CM} \leq 80\text{ V}$			300		mV
<b>VOLTAGE OUTPUT <sup>(5)</sup></b>							
	Output Swing to the Positive Rail	$V_{IN-} = 11\text{ V}$ , $V_{IN+} = 12\text{ V}$	$T_A = -40^\circ\text{C}$ to $125^\circ\text{C}$		$(V_S) - 0.15$	$(V_S) - 0.25$	V
	Output Swing to GND <sup>(6)</sup>	$V_{IN-} = 0\text{ V}$ , $V_{IN+} = -0.5\text{ V}$	$T_A = -40^\circ\text{C}$ to $125^\circ\text{C}$		$(V_{GND}) + 0.004$	$(V_{GND}) + 0.05$	V

At  $T_A = 25^\circ\text{C}$ ,  $V_S = 12\text{ V}$ ,  $V_{CM} = 12\text{ V}$ ,  $V_{SENSE} = 100\text{ mV}$ ,  $R_L = 10\text{ k}\Omega$  to GND,  $R_{pullup} = 5.1\text{ k}\Omega$  each connected from CMP1 OUT and CMP2 OUT to  $V_S$ , and CMP1 IN+ = 1 V and CMP2 IN- = GND, unless otherwise noted.

PARAMETER		TEST CONDITIONS	MIN	TYP	MAX	UNIT
<b>FREQUENCY RESPONSE</b>						
BW	Bandwidth	INA203; $C_{LOAD} = 5\text{ pF}$		500		kHz
		INA204; $C_{LOAD} = 5\text{ pF}$		300		kHz
		INA205; $C_{LOAD} = 5\text{ pF}$		200		kHz
	Phase Margin	$C_{LOAD} < 10\text{ nF}$		40		
SR	Slew Rate			1		V/ $\mu\text{s}$
	Settling Time (1%)	$V_{SENSE} = 10\text{ mV}_{PP}$ to $100\text{ mV}_{PP}$ , $C_{LOAD} = 5\text{ pF}$		2		$\mu\text{s}$
<b>NOISE, RTI</b>						
	Output Voltage Noise Density			40		nV/ $\sqrt{\text{Hz}}$

- Offset is extrapolated from measurements of the output at 20 mV and 100 mV  $V_{SENSE}$ .
- Total output error includes effects of gain error and  $V_{OS}$ .
- Linearity is best fit to a straight line.
- For details on this region of operation, see the [Accuracy Variations as a Result Of  \$V\_{SENSE}\$  and Common-Mode Voltage](#) section in the [Application and Implementation](#).
- See Typical Characteristic curve *Positive Output Voltage Swing vs. Output Current* (图 6-8).
- Specified by design; not production tested.

## 6.6 Electrical Characteristics: Comparator

At  $T_A = 25^\circ\text{C}$ ,  $V_S = 12\text{ V}$ ,  $V_{CM} = 12\text{ V}$ ,  $V_{SENSE} = 100\text{ mV}$ ,  $R_L = 10\text{ k}\Omega$  to GND, and  $R_{pullup} = 5.1\text{ k}\Omega$  each connected from CMP1 OUT and CMP2 OUT to  $V_S$ , unless otherwise noted.

PARAMETER		TEST CONDITIONS	MIN	TYP	MAX	UNIT
<b>OFFSET VOLTAGE</b>						
Offset Voltage		Comparator Common-Mode Voltage = Threshold Voltage		2		mV
Offset Voltage Drift, Comparator 1		$T_A = -40^\circ\text{C}$ to $125^\circ\text{C}$		$\pm 2$		$\mu\text{V}/^\circ\text{C}$
Offset Voltage Drift, Comparator 2		$T_A = -40^\circ\text{C}$ to $125^\circ\text{C}$		5.4		$\mu\text{V}/^\circ\text{C}$
Threshold		$T_A = 25^\circ\text{C}$	590	608	620	mV
Threshold over Temperature		$T_A = -40^\circ\text{C}$ to $125^\circ\text{C}$	586		625	mV
Hysteresis <sup>(1)</sup> , CMP1		$T_A = -40^\circ\text{C}$ to $85^\circ\text{C}$		- 8		mV
Hysteresis <sup>(1)</sup> , CMP2		$T_A = -40^\circ\text{C}$ to $85^\circ\text{C}$		8		mV
<b>INPUT BIAS CURRENT <sup>(2)</sup></b>						
CMP1 IN+, CMP2 IN+				0.005	10	nA
CMP1 IN+, CMP2 IN+ vs. Temperature		$T_A = -40^\circ\text{C}$ to $125^\circ\text{C}$			15	nA
<b>INPUT IMPEDANCE</b>						
Pins 3 and 6 (14-pin packages only)				10		k $\Omega$
<b>INPUT RANGE</b>						
CMP1 IN+ and CMP2 IN+			0 V to $V_S - 1.5\text{ V}$			V
Pins 3 and 6 (14-pin packages only) <sup>(3)</sup>			0 V to $V_S - 1.5\text{ V}$			V
<b>OUTPUT</b>						
Large-Signal Differential Voltage Gain		CMP $V_{OUT}$ 1 V to 4 V, $R_L \geq 15\text{ k}\Omega$ Connected to 5 V		200		V/mV

At  $T_A = 25^\circ\text{C}$ ,  $V_S = 12\text{ V}$ ,  $V_{CM} = 12\text{ V}$ ,  $V_{SENSE} = 100\text{ mV}$ ,  $R_L = 10\text{ k}\Omega$  to GND, and  $R_{pullup} = 5.1\text{ k}\Omega$  each connected from CMP1 OUT and CMP2 OUT to  $V_S$ , unless otherwise noted.

PARAMETER	TEST CONDITIONS	MIN	TYP	MAX	UNIT
High-Level Output Current	$V_{ID} = 0.4\text{ V}$ , $V_{OH} = V_S$		0.0001	1	$\mu\text{ A}$
Low-Level Output Voltage	$V_{ID} = -0.6\text{ V}$ , $I_{OL} = 2.35\text{ mA}$		220	300	mV
<b>RESPONSE TIME</b> <sup>(4)</sup>					
Comparator 1	$R_L$ to 5 V, $C_L = 15\text{ pF}$ , 100-mV Input Step with 5-mV Overdrive		1.3		$\mu\text{ s}$
Comparator 2	$R_L$ to 5 V, $C_L = 15\text{ pF}$ , 100-mV Input Step with 5-mV Overdrive, $C_{DELAY}$ Pin Open		1.3		$\mu\text{ s}$
<b>RESET</b>					
RESET Threshold <sup>(5)</sup>			1.1		V
Logic Input Impedance			2		$\text{M}\Omega$
Minimum RESET Pulse Width			1.5		$\mu\text{ s}$
RESET Propagation Delay			3		$\mu\text{ s}$
Comparator 2 Delay Equation <sup>(6)</sup>			$C_{DELAY} = t_D/5$		$\mu\text{ F}$
$t_D$ Comparator 2 Delay	$C_{DELAY} = 0.1\ \mu\text{ F}$		0.5		s

- (1) Hysteresis refers to the threshold (the threshold specification applies to a rising edge of a noninverting input) of a falling edge on the noninverting input of the comparator; refer to [Figure 6-1](#).
- (2) Specified by design; not production tested.
- (3) See the [Comparator Maximum Input Voltage Range](#) section in the [Application and Implementation](#).
- (4) The comparator response time specified is the interval between the input step function and the instant when the output crosses 1.4 V.
- (5) The CMP1 RESET input has an internal 2-M $\Omega$  (typical) pulldown. Leaving the CMP1 RESET open results in a LOW state, with transparent comparator operation.
- (6) The Comparator 2 delay applies to both rising and falling edges of the comparator output.



**图 6-1. Comparator Hysteresis**



## 6.7 Electrical Characteristics: Reference

At  $T_A = 25^\circ\text{C}$ ,  $V_S = 12\text{ V}$ ,  $V_{CM} = 12\text{ V}$ ,  $V_{SENSE} = 100\text{ mV}$ ,  $R_L = 10\text{ k}\Omega$  to GND, and  $R_{pullup} = 5.1\text{ k}\Omega$  each connected from CMP1 OUT and CMP2 OUT to  $V_S$ , unless otherwise noted.

PARAMETER	TEST CONDITIONS	MIN	TYP	MAX	UNIT
<b>REFERENCE VOLTAGE</b>					
1.2- $V_{REFOUT}$ Output Voltage		1.188	1.2	1.212	V
$dV_{OUT}/dT$ Reference Drift	$T_A = -40^\circ\text{C}$ to $85^\circ\text{C}$		40	100	ppm/ $^\circ\text{C}$
0.6- $V_{REF}$ Output Voltage	Pins 3 and 6 of 14-pin packages only		0.6		V
$dV_{OUT}/dT$ Reference Drift	$T_A = -40^\circ\text{C}$ to $85^\circ\text{C}$		40	100	ppm/ $^\circ\text{C}$
<b>LOAD REGULATION</b> $dV_{OUT}/dI_{LOAD}$					
Sourcing	$0\text{mA} < I_{SOURCE} < 0.5\text{mA}$		0.4	2	mV/mA
Sinking	$0\text{mA} < I_{SINK} < 0.5\text{mA}$		0.4		mV/mA
$I_{LOAD}$ Load Current			1		mA
$dV_{OUT}/dV_S$ Line Regulation	$2.7\text{ V} < V_S < 18\text{ V}$		30		$\mu\text{ V/V}$
<b>CAPACITIVE LOAD</b>					
Reference Output Maximum Capacitive Load	No Sustained Oscillations		10		nF
<b>OUTPUT IMPEDANCE</b>					
Output Impedance	Pins 3 and 6 of 14-Pin Packages Only		10		$\text{k}\Omega$

## 6.8 Electrical Characteristics: General

All specifications at  $T_A = 25^\circ\text{C}$ ,  $V_S = 12\text{ V}$ ,  $V_{CM} = 12\text{ V}$ ,  $V_{SENSE} = 100\text{ mV}$ ,  $R_L = 10\text{ k}\Omega$  to GND,  $R_{pullup} = 5.1\text{ k}\Omega$  each connected from CMP1 OUT and CMP2 OUT to  $V_S$ , and CMP1 IN+ = 1 V and CMP2 IN- = GND, unless otherwise noted.

PARAMETER	TEST CONDITIONS	MIN	TYP	MAX	UNIT
<b>POWER SUPPLY</b>					
$V_S$ Operating power supply	$T_A = -40^\circ\text{C}$ to $125^\circ\text{C}$	2.7		18	V
$I_Q$ Quiescent current	$V_{OUT} = 2\text{ V}$		1.8	2.2	mA
Quiescent current over temperature	$V_{SENSE} = 0\text{ mV}$			2.8	mA
Comparator power-on reset threshold <sup>(1)</sup>			1.5		V
<b>TEMPERATURE</b>					
Specified temperature		-40		125	$^\circ\text{C}$
Operating temperature		-55		150	$^\circ\text{C}$

- (1) The INA203, INA204, and INA205 are designed to power-up with the comparator in a defined reset state as long as CMP1 RESET is open or grounded. The comparator will be in reset as long as the power supply is below the voltage shown here. The comparator assumes a state based on the comparator input above this supply voltage. If CMP1 RESET is high at power-up, the comparator output comes up high and requires a reset to assume a low state, if appropriate.

### 6.9 Typical Characteristics

All specifications at  $T_A = 25^\circ\text{C}$ ,  $V_S = 12\text{ V}$ ,  $V_{CM} = 12\text{ V}$ , and  $V_{SENSE} = 100\text{ mV}$ , unless otherwise noted.



图 6-2. Gain vs. Frequency



图 6-3. Gain vs. Frequency

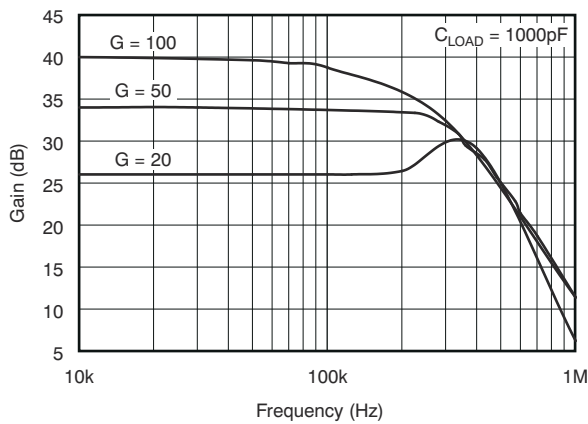

图 6-4. Gain Plot

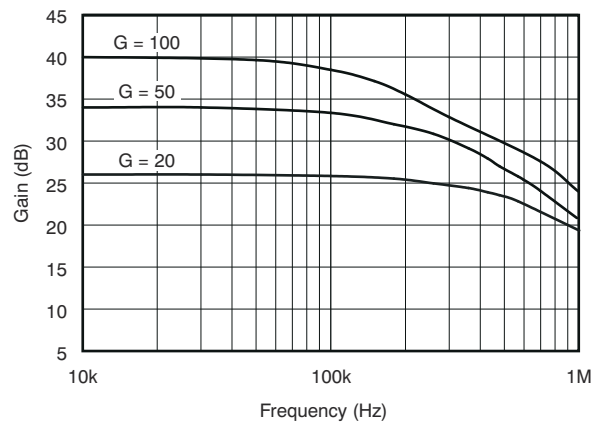

图 6-5. Common-Mode and Power-Supply Rejection vs. Frequency

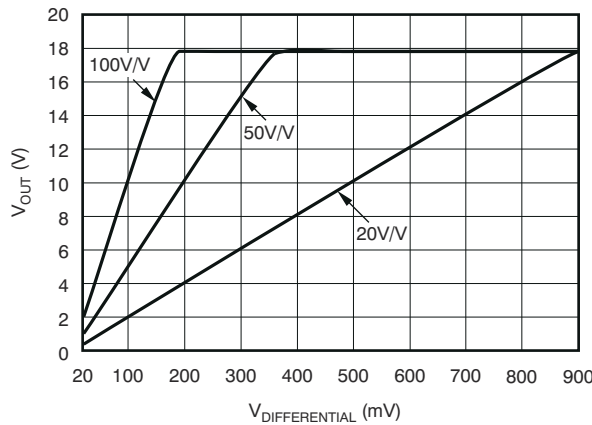

图 6-6. Total Output Error vs.  $V_{SENSE}$

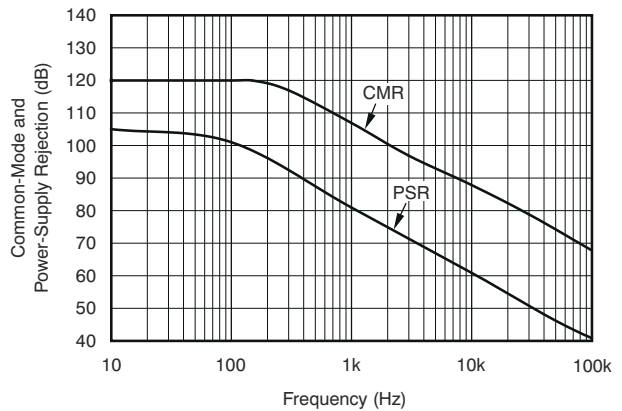

图 6-7. Total Output Error vs. Common-Mode Voltage

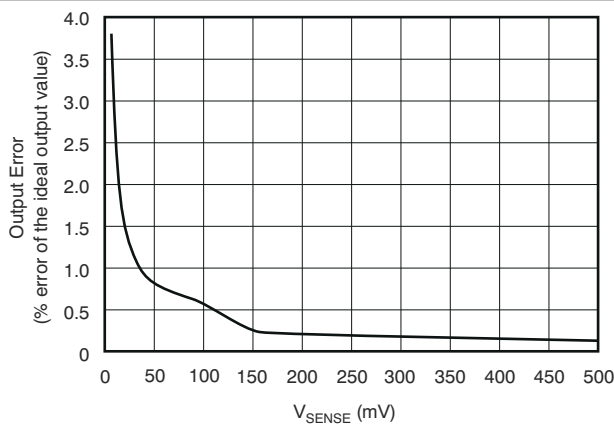

**图 6-8. Positive Output Voltage Swing vs. Output Current**

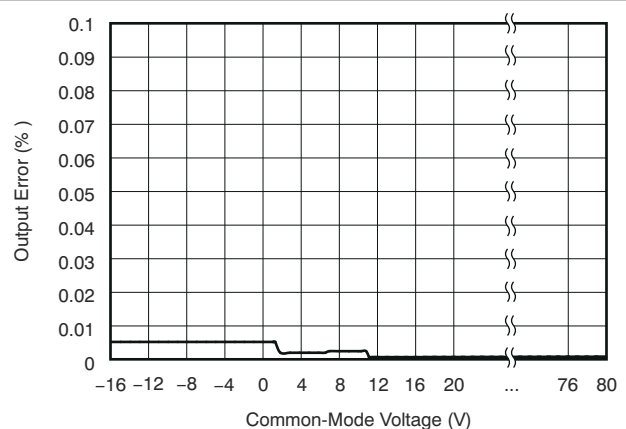
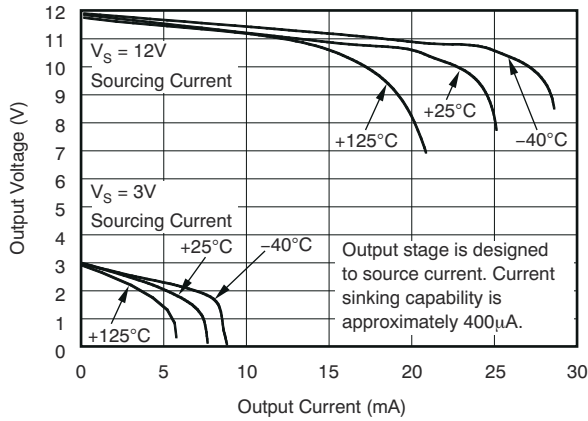
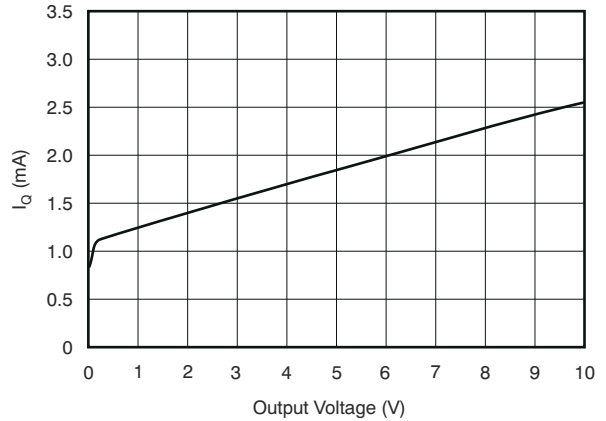

**图 6-9. Quiescent Current vs. Output Voltage**

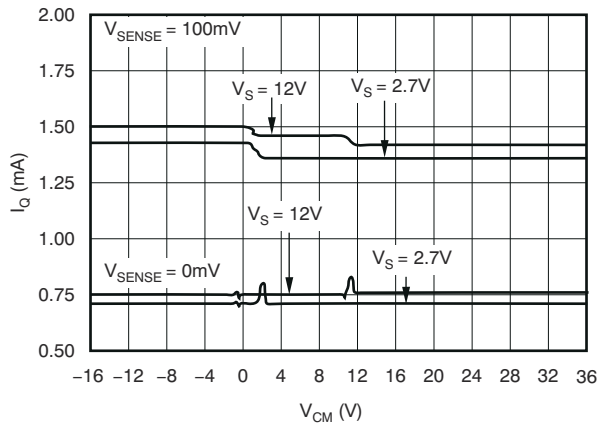

**图 6-10. Quiescent Current vs. Common-Mode Voltage**

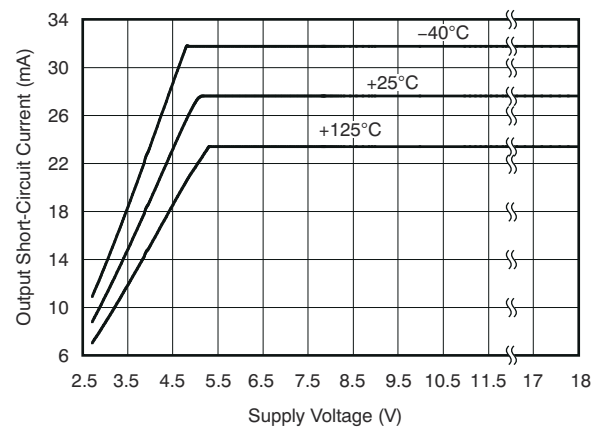

**图 6-11. Output Short-Circuit Current vs. Supply Voltage**

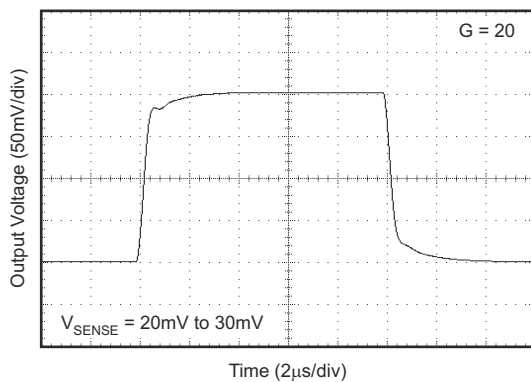

**图 6-12. Step Response**

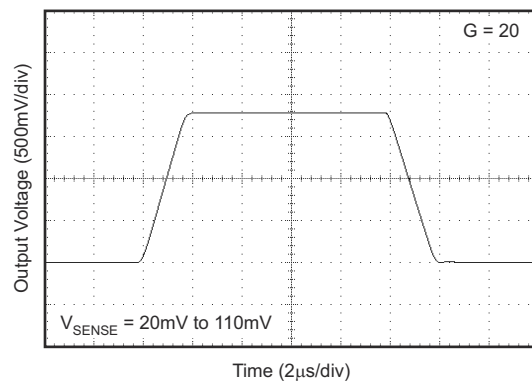

**图 6-13. Step Response**



图 6-14. Step Response



图 6-15. Step Response

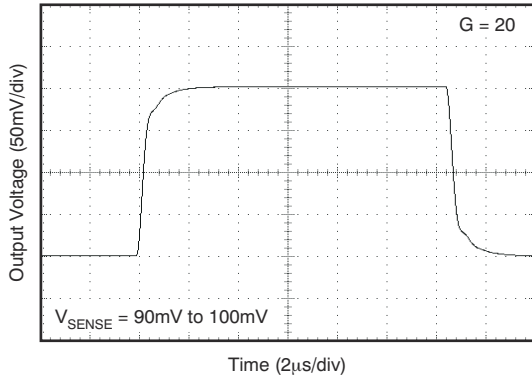

图 6-16. Step Response

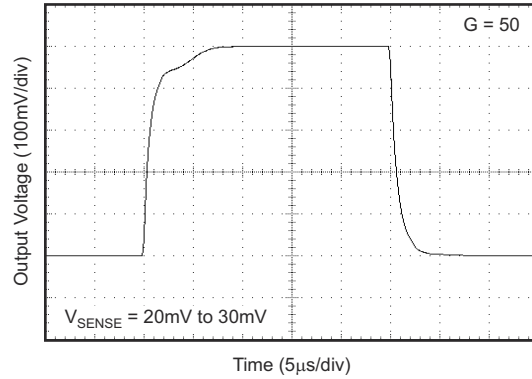

图 6-17. Step Response

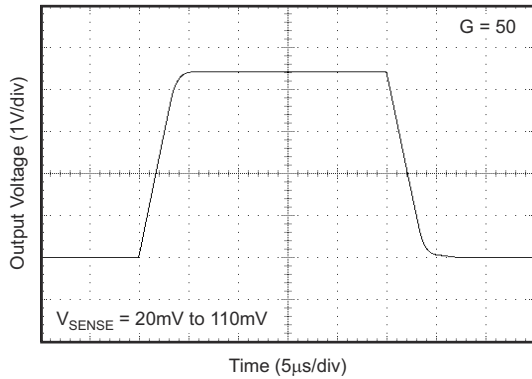

图 6-18. Step Response

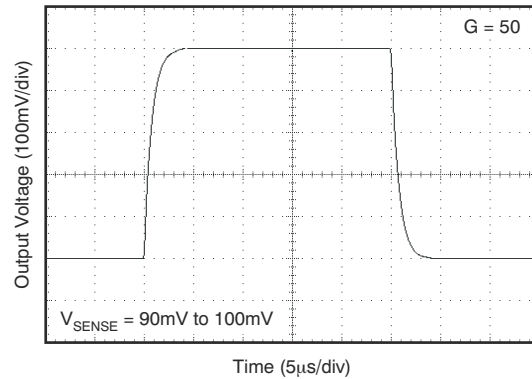

图 6-19. Comparator  $V_{OL}$  vs.  $I_{SINK}$

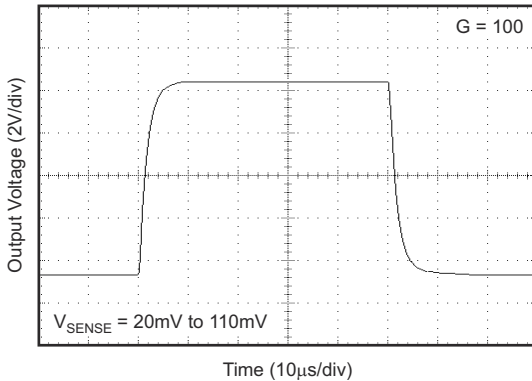

图 6-20. Comparator Trip Point vs. Supply Voltage

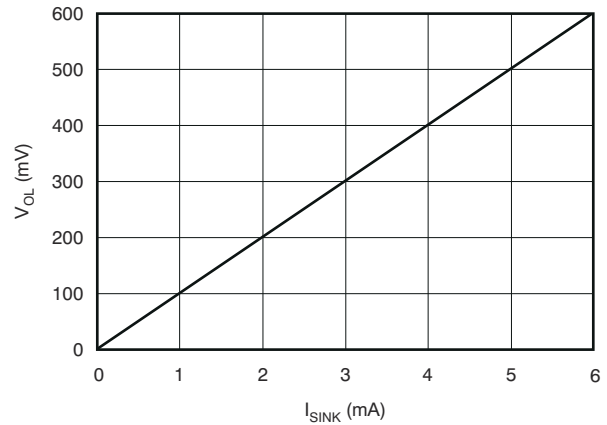

图 6-21. Comparator Trip Point vs. Temperature

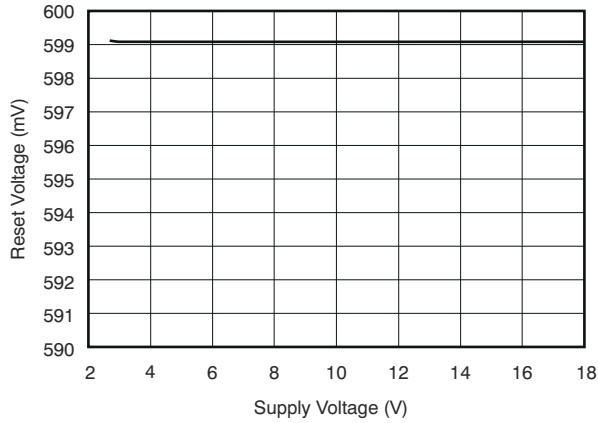

图 6-22. Comparator 1 Propagation Delay vs. Overdrive Voltage

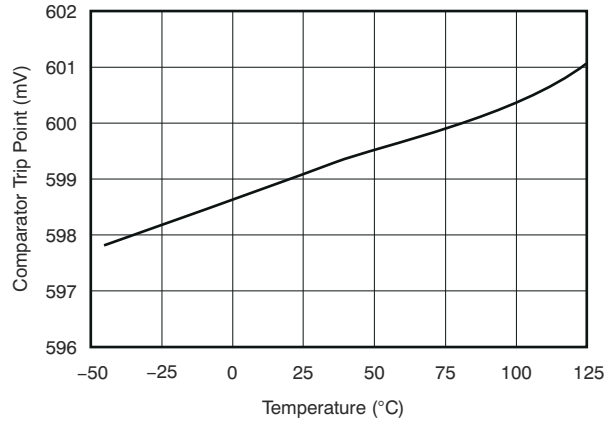

图 6-23. Comparator Reset Voltage vs. supply Voltage

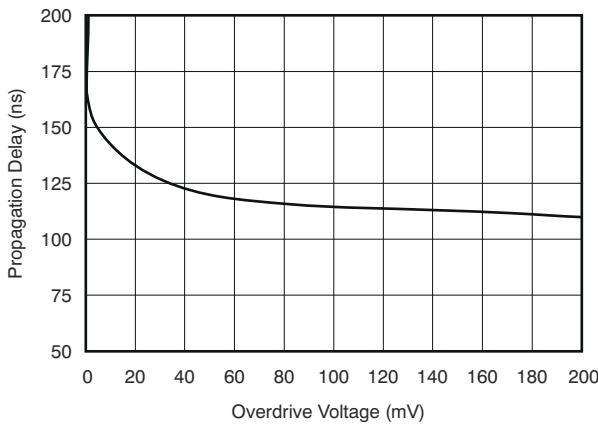

图 6-24. Comparator Propagation Delay vs. Temperature

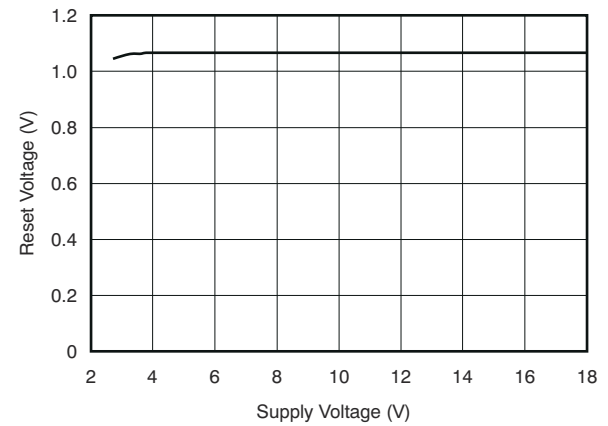

图 6-25. Comparator Propagation Delay

## 7 Detailed Description

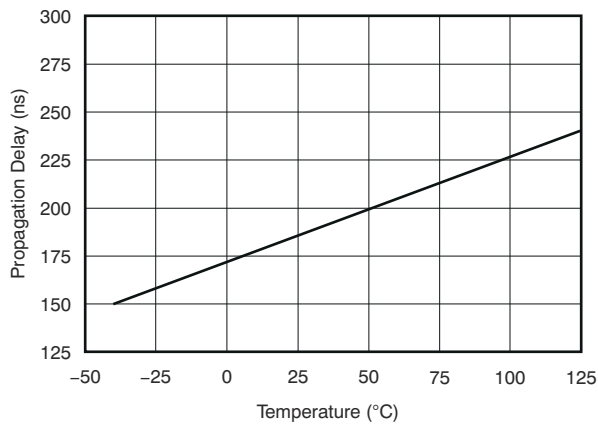
### 7.1 Overview

The INA203, INA204, and INA205 are a family of unidirectional current-shunt monitors with voltage output, dual comparators, and voltage reference. The INA203, INA204, and INA205 can sense drops across shunts at common-mode voltages from  $-16\text{ V}$  to  $80\text{ V}$ . The INA203, INA204, and INA205 are available with three output voltage scales:  $20\text{ V/V}$ ,  $50\text{ V/V}$ , and  $100\text{ V/V}$ , with up to  $500\text{-kHz}$  bandwidth. The INA203, INA204, and INA205 also incorporate two open-drain comparators with internal  $0.6\text{-V}$  references. On 14-pin versions, the comparator references can be overridden by external inputs. Comparator 1 includes a latching capability, and Comparator 2 has a user-programmable delay. 14-pin versions also provide a  $1.2\text{-V}$  reference output. The INA203, INA204, and INA205 operate from a single  $2.7\text{-V}$  to  $18\text{-V}$  supply. They are specified over the extended operating temperature range of  $-40^\circ\text{C}$  to  $125^\circ\text{C}$ .

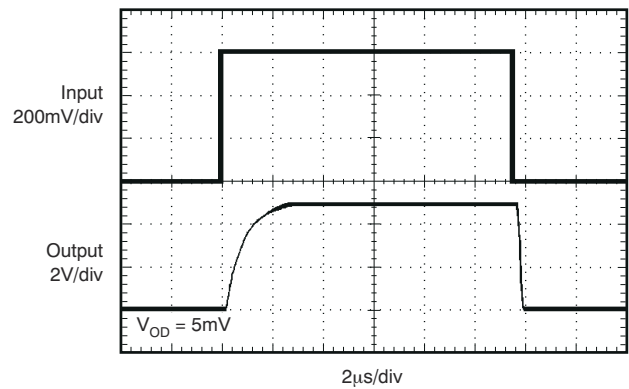
### 7.2 Functional Block Diagrams



图 7-1. SO-14, TSSOP-14 Functional Block Diagram



图 7-2. VSSOP-10 Functional Block Diagram

## 7.3 Feature Description

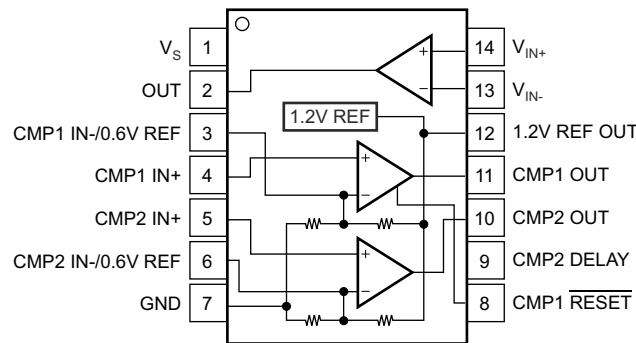
### 7.3.1 Basic Connections

图 7-3 shows the basic connections of the INA203, INA204, and INA205. The input pins,  $V_{IN+}$  and  $V_{IN-}$ , should be connected as closely as possible to the shunt resistor to minimize any resistance in series with the shunt resistance.

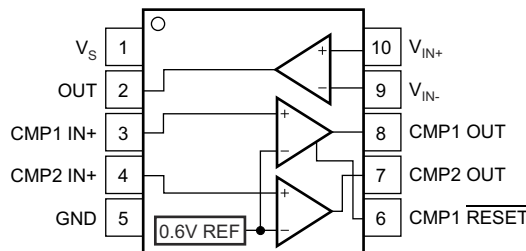
Power-supply bypass capacitors are required for stability. Applications with noisy or high-impedance power supplies may require additional decoupling capacitors to reject power-supply noise. Connect bypass capacitors close to the device pins.



图 7-3. INA20x Basic Connection

### 7.3.2 Selecting $R_{SHUNT}$

The value chosen for the shunt resistor,  $R_{SHUNT}$ , depends on the application and is a compromise between small-signal accuracy and maximum permissible voltage loss in the measurement line. High values of  $R_{SHUNT}$  provide better accuracy at lower currents by minimizing the effects of offset, while low values of  $R_{SHUNT}$  minimize voltage loss in the supply line. For most applications, best performance is attained with an  $R_{SHUNT}$  value that provides a full-scale shunt voltage range of 50 mV to 100 mV. Maximum input voltage for accurate measurements is  $(V_{OUT} - 0.25) / \text{Gain}$ .

### 7.3.3 Comparator

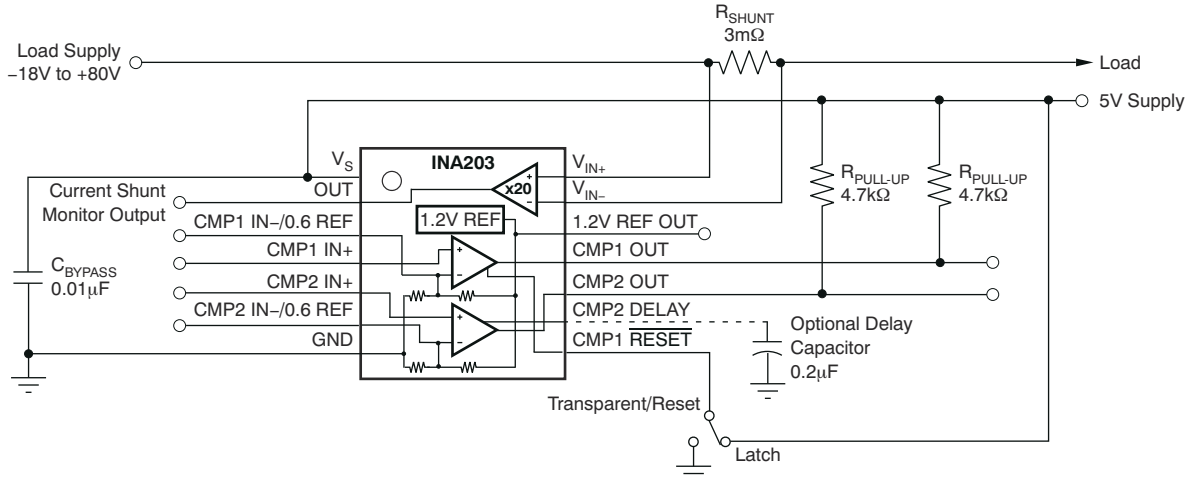
The INA203, INA204, and INA205 devices incorporate two open-drain comparators. These comparators typically have 2 mV of offset and a 1.3-  $\mu$ s (typical) response time. The output of Comparator 1 latches and is reset through the CMP1 RESET pin, as shown in 图 7-5. This configuration applies to both the 10- and 14-pin versions. 图 7-4 illustrates the comparator delay.

The 14-pin versions of the INA203, INA204, and INA205 devices include additional features for comparator functions. The comparator reference voltage of both Comparator 1 and Comparator 2 can be overridden by external inputs for increased design flexibility. Comparator 2 has a programmable delay.

### 7.3.4 Comparator Delay (14-Pin Version Only)

The Comparator 2 programmable delay is controlled by a capacitor connected to the CMP2 Delay Pin; see 图 7-3. The capacitor value (in  $\mu$ F) is selected by using 方程式 1:

$$C_{DELAY} \text{ (in } \mu\text{F)} = \frac{t_D}{5} \quad (1)$$

A simplified version of the delay circuit for Comparator 2 is shown in 图 7-4. The delay comparator consists of two comparator stages with the delay between them. I1 and I2 cannot be turned on simultaneously; I1 corresponds to a U1 low output and I2 corresponds to a U1 high output. Using an initial assumption that the U1 output is low, I1 is on, then U2 +IN is zero. If U1 goes high, I2 supplies 120 nA to  $C_{DELAY}$ . The voltage at U2 +IN begins to ramp toward a 0.6-V threshold. When the voltage crosses this threshold, the U2 output goes high while the voltage at U2 +IN continues to ramp up to a maximum of 1.2 V when given sufficient time (twice the value of the delay specified for  $C_{DELAY}$ ). This entire sequence is reversed when the comparator outputs go low, so that returning to low exhibits the same delay.



图 7-4. Simplified Model of the Comparator 2 Delay Circuit



图 7-5. Comparator Latching Capability

Take care to note what will happen if events occur more rapidly than the delay timeout; for example, when the U1 output goes high (turning on I2), but returns low (turning I1 back on) prior to reaching the 0.6-V transition for U2. The voltage at U2 +IN ramps back down at a rate determined by the value of  $C_{DELAY}$ , and only returns to zero if given sufficient time.

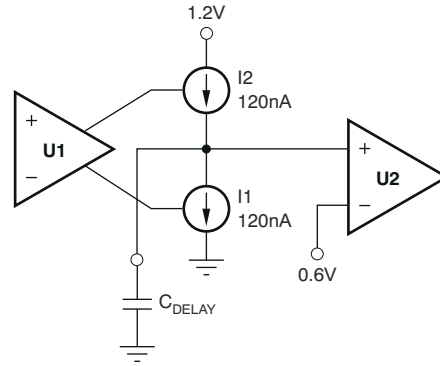
In essence, when analyzing Comparator 2 for behavior with events more rapid than its delay setting, use the model shown in 图 7-4.

### 7.3.5 Comparator Maximum Input Voltage Range

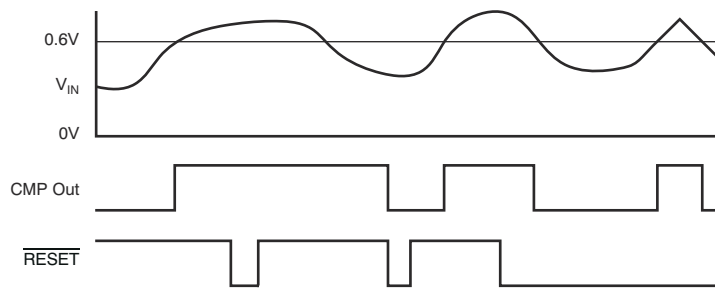
The maximum voltage at the comparator input for normal operation is up to  $(V_s) - 1.5$  V. There are special considerations when overdriving the reference inputs (pins 3 and 6). Driving either or both inputs high enough to drive 1 mA back into the reference introduces errors into the reference. 图 7-6 shows the basic input structure. A general guideline is to limit the voltage on both inputs to a total of 20 V. The exact limit depends on the available voltage and whether either or both inputs are subject to the large voltage. When making this determination, consider the 20 k $\Omega$  from each input back to the comparator. 图 7-7 shows the maximum input voltage that avoids creating a reference error when driving both inputs (an equivalent resistance back into the reference of 10 k $\Omega$ ).



图 7-6. Limit Current Into Reference  $\leq 1$  mA





**图 7-7. Overdriving Comparator Inputs Without Generating a Reference Error**

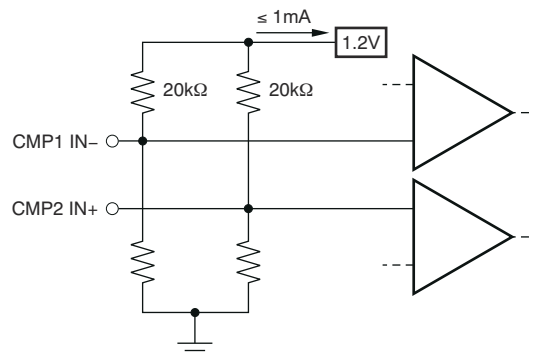
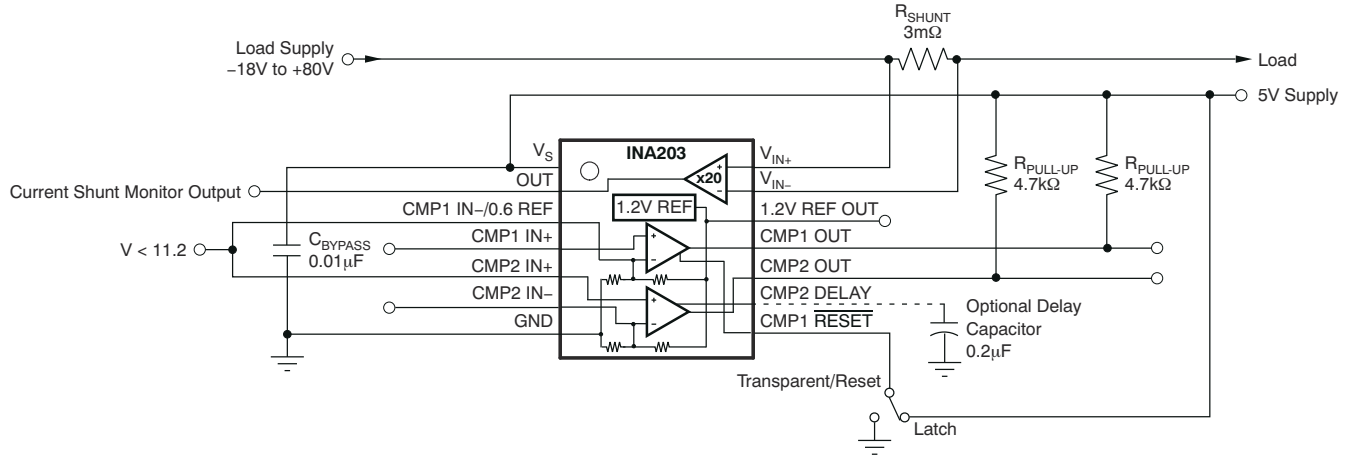
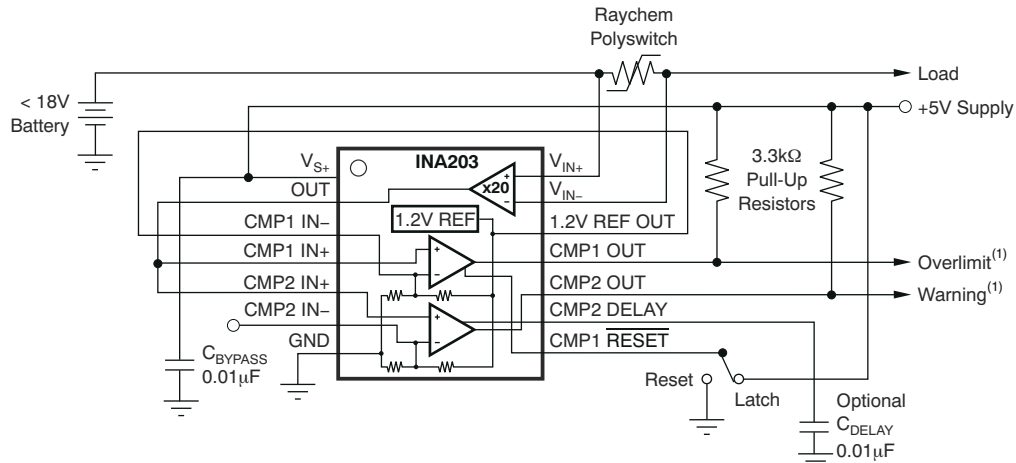

NOTE: (1) Warning at half current (with optional delay). Overlimit latches when Polyswitch opens.

**图 7-8. Polyswitch Warning and Fault Detection Circuit**



图 7-9. Lead-Acid Battery Protection Circuit

## 7.4 Device Functional Modes

### 7.4.1 Input Filtering

An obvious and straightforward location for filtering is at the output of the INA203, INA204, and INA205 series; however, this location negates the advantage of the low output impedance of the internal buffer. The only other option for filtering is at the input pins of the INA203, INA204, and INA205, which is complicated by the internal  $5\text{ k}\Omega + 30\%$  input impedance; this configuration is illustrated in 图 7-10. Using the lowest possible resistor values minimizes both the initial shift in gain and effects of tolerance. Use 方程式 2 to calculate the effect on initial gain.

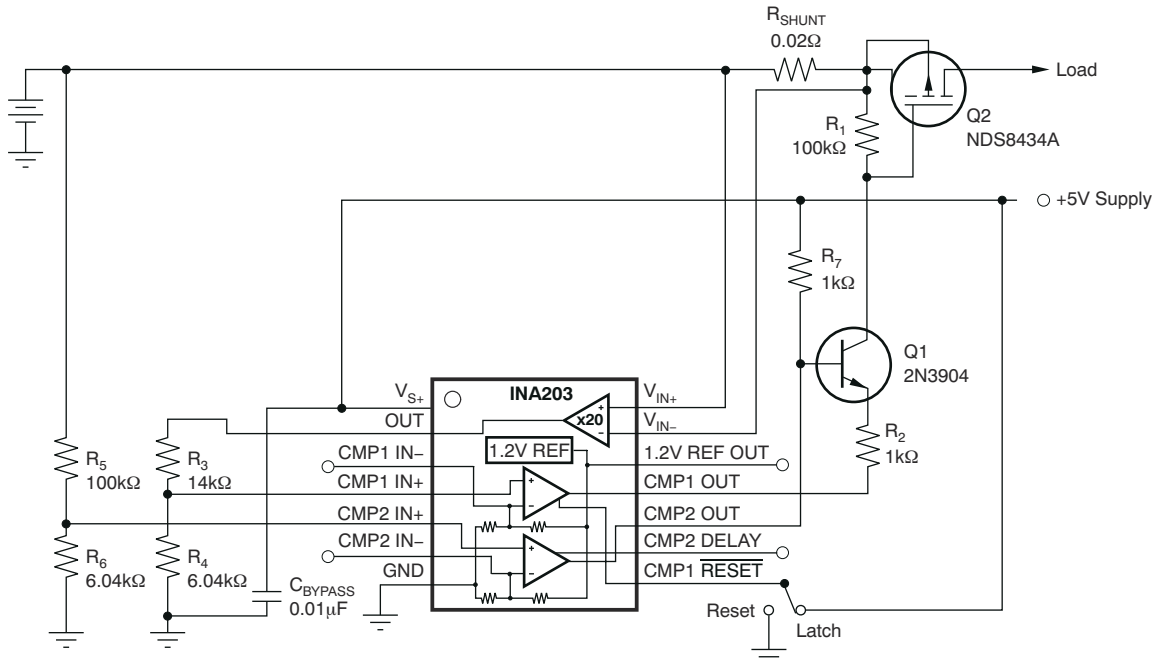
$$\text{Gain Error \%} = 100 - \left( 100 \times \frac{5\text{ k}\Omega}{5\text{ k}\Omega + R_{\text{FILT}}} \right) \quad (2)$$

Total effect on gain error can be calculated by replacing the  $5\text{-k}\Omega$  term with  $5\text{ k}\Omega - 30\%$ , (or  $3.5\text{ k}\Omega$ ) or  $5\text{ k}\Omega + 30\%$  (or  $6.5\text{ k}\Omega$ ). The tolerance extremes of  $R_{\text{FILT}}$  can also be inserted into the equation. If a pair of  $100\ \Omega$  1% resistors are used on the inputs, the initial gain error will be 1.96%. Worst-case tolerance conditions will always occur at the lower excursion of the internal  $5\text{-k}\Omega$  resistor ( $3.5\text{ k}\Omega$ ), and the higher excursion of  $R_{\text{FILT}} - 3\%$  in this case.



图 7-10. Input Filter (Gain Error: 1.5% to -2.2%)

The specified accuracy of the INA203, INA204, and INA205 must then be combined in addition to these tolerances. While this discussion treated accuracy worst-case conditions by combining the extremes of the resistor values, it is appropriate to use geometric mean or root sum square calculations to total the effects of accuracy variations.

#### 7.4.2 Accuracy Variations as a Result Of $V_{SENSE}$ and Common-Mode Voltage

The accuracy of the INA203, INA204, and INA205 current shunt monitors is a function of two main variables:  $V_{SENSE}$  ( $V_{IN+} - V_{IN-}$ ) and common-mode voltage,  $V_{CM}$ , relative to the supply voltage,  $V_S$ .  $V_{CM}$  is expressed as  $(V_{IN+} + V_{IN-}) / 2$ ; however, in practice,  $V_{CM}$  is seen as the voltage at  $V_{IN+}$  because the voltage drop across  $V_{SENSE}$  is usually small.

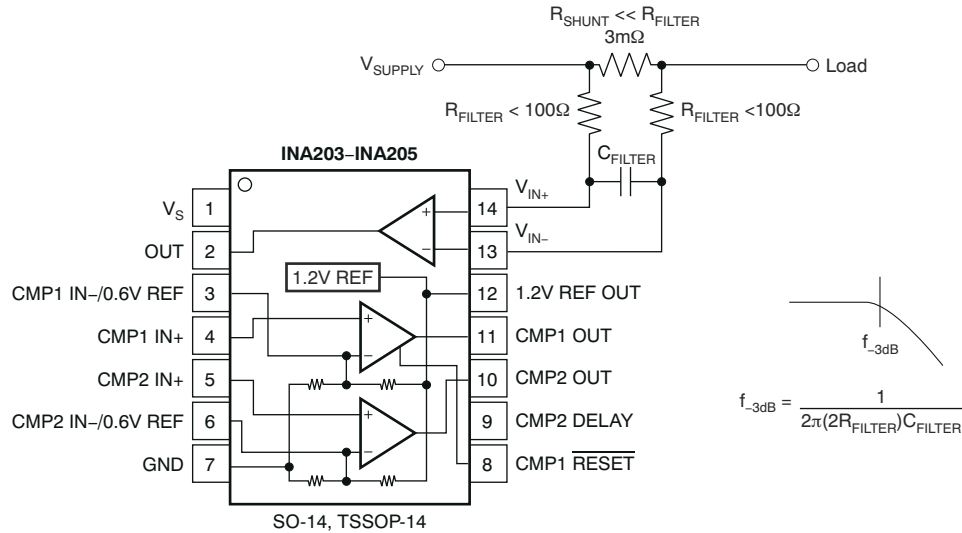
This section addresses the accuracy of these specific operating regions:

- Normal Case 1:  $V_{SENSE} \geq 20 \text{ mV}$ ,  $V_{CM} \geq V_S$
- Normal Case 2:  $V_{SENSE} \geq 20 \text{ mV}$ ,  $V_{CM} < V_S$
- Low  $V_{SENSE}$  Case 1:  $V_{SENSE} < 20 \text{ mV}$ ,  $-16 \text{ V} \leq V_{CM} < 0$
- Low  $V_{SENSE}$  Case 2:  $V_{SENSE} < 20 \text{ mV}$ ,  $0 \text{ V} \leq V_{CM} \leq V_S$
- Low  $V_{SENSE}$  Case 3:  $V_{SENSE} < 20 \text{ mV}$ ,  $V_S < V_{CM} \leq 80 \text{ V}$

##### 7.4.2.1 Normal Case 1: $V_{SENSE} \geq 20 \text{ mV}$ , $V_{CM} \geq V_S$

This region of operation provides the highest accuracy. Here, the input offset voltage is characterized and measured using a two-step method. First, the gain is determined by 方程式 3.

$$G = \frac{V_{OUT1} - V_{OUT2}}{100\text{mV} - 20\text{mV}} \quad (3)$$

where

- $V_{OUT1}$  = Output Voltage with  $V_{SENSE} = 100 \text{ mV}$ .
- $V_{OUT2}$  = Output Voltage with  $V_{SENSE} = 20 \text{ mV}$ .

Then the offset voltage is measured at  $V_{SENSE} = 100 \text{ mV}$  and referred to the input (RTI) of the current shunt monitor, as shown in 方程式 4.

$$V_{OS \text{ RTI (Referred-To-Input)}} = \left[ \frac{V_{OUT1}}{G} \right] - 100\text{mV} \quad (4)$$

In the *Typical Characteristics*, 图 6-7 shows the highest accuracy for this region of operation. In this plot,  $V_S = 12$  V; for  $V_{CM} \geq 12$  V, the output error is at its minimum. This case is also used to create the  $V_{SENSE} \geq 20$ -mV output specifications in the *Electrical Characteristics: Current-Shunt Monitor* table.

#### 7.4.2.2 Normal Case 2: $V_{SENSE} \geq 20$ mV, $V_{CM} < V_S$

This region of operation has slightly less accuracy than Normal Case 1 as a result of the common-mode operating area in which the part functions, as seen in 图 6-7. As noted, for this graph  $V_S = 12$  V; for  $V_{CM} < 12$  V, the Output Error increases as  $V_{CM}$  becomes less than 12 V, with a typical maximum error of 0.005% at the most negative  $V_{CM} = -16$  V.

#### 7.4.2.3 Low $V_{SENSE}$ Case 1

- $V_{SENSE} < 20$  mV,  $-16$  V  $\leq V_{CM} < 0$ ;
- Low  $V_{SENSE}$  Case 3:
- $V_{SENSE} < 20$  mV,  $V_S < V_{CM} \leq 80$  V

Although the INA203 family of devices are not designed for accurate operation in either of these regions, some applications are exposed to these conditions; for example, when monitoring power supplies that are switched on and off while  $V_S$  is still applied to the INA203, INA204, or INA205. Take care to know what the behavior of the devices will be in these regions.

As  $V_{SENSE}$  approaches 0 mV, in these  $V_{CM}$  regions, the device output accuracy degrades. A larger-than-normal offset can appear at the current shunt monitor output with a typical maximum value of  $V_{OUT} = 300$  mV for  $V_{SENSE} = 0$  mV. As  $V_{SENSE}$  approaches 20 mV,  $V_{OUT}$  returns to the expected output value with accuracy as specified in the *Electrical Characteristics: Current-Shunt Monitor*. 图 7-11 illustrates this effect using the INA205 (Gain = 100).



图 7-11. Example for Low  $V_{SENSE}$  Cases 1 and 3 (INA205, Gain = 100)

#### 7.4.2.4 Low $V_{SENSE}$ Case 2: $V_{SENSE} < 20$ mV, $0$ V $\leq V_{CM} \leq V_S$

This region of operation is the least accurate for the INA203 family. To achieve the wide input common-mode voltage range, these devices use two op amp front ends in parallel. One operational amplifier front end operates in the positive input common-mode voltage range, and the other in the negative input region. For this case, neither of these two internal amplifiers dominates and overall loop gain is very low. Within this region,  $V_{OUT}$  approaches voltages close to linear operation levels for Normal Case 2. This deviation from linear operation becomes greatest the closer  $V_{SENSE}$  approaches 0 V. Within this region, as  $V_{SENSE}$  approaches 20 mV, device operation is closer to that described by Normal Case 2. 图 7-12 illustrates this behavior for the INA205. The  $V_{OUT}$  maximum peak for this case is tested by maintaining a constant  $V_S$ , setting  $V_{SENSE} = 0$  mV, and sweeping  $V_{CM}$  from 0 V to  $V_S$ . The exact  $V_{CM}$  at which  $V_{OUT}$  peaks during this test varies from part to part, but the  $V_{OUT}$  maximum peak is tested to be less than the specified  $V_{OUT}$  Tested Limit.

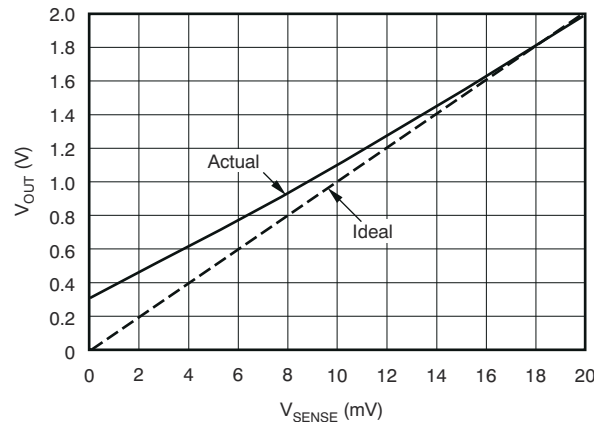
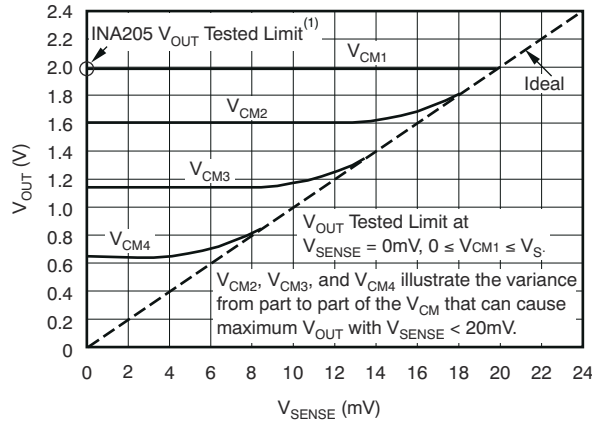

NOTE: (1) INA203  $V_{OUT}$  Tested Limit = 0.4V. INA204  $V_{OUT}$  Tested Limit = 1V.

图 7-12. Example For Low  $V_{SENSE}$  Case 2 (INA205, Gain = 100)

### 7.4.3 Transient Protection

The -16 V to 80 V common-mode range of the INA203, INA204, and INA205 is ideal for withstanding automotive fault conditions ranging from 12-V battery reversal up to 80-V transients, since no additional protective components are needed up to those levels. In the event that the INA203, INA204, and INA205 are exposed to transients on the inputs in excess of their ratings, then external transient absorption with semiconductor transient absorbers (Zeners or *Transzorbs*) are necessary. Use of metal oxide varistors (MOVs) or video disk recorders (VDRs) is not recommended except when they are used in addition to a semiconductor transient absorber. Select the transient absorber such that it will never allow the INA203, INA204, and INA205 to be exposed to transients greater than 80 V (that is, allow for transient absorber tolerance, as well as additional voltage because of transient absorber dynamic impedance). Despite the use of internal Zener-type ESD protection, the INA203, INA204, and INA205 do not lend themselves to using external resistors in series with the inputs because the internal gain resistors can vary up to  $\pm 30\%$  but are closely matched. (If gain accuracy is not important, then resistors can be added in series with the INA203, INA204, and INA205 inputs with two equal resistors on each input.)

### 7.4.4 Output Voltage Range

The output of the INA203, INA204, and INA205 is accurate within the output voltage swing range set by the power-supply pin,  $V_S$ . This performance is best illustrated when using the INA205 (a gain of 100 version), where a 100-mV full-scale input from the shunt resistor requires an output voltage swing of 10 V, and a power-supply voltage sufficient to achieve 10 V on the output.

### 7.4.5 Reference

The INA203, INA204, and INA205 include an internal voltage reference that has a load regulation of 0.4 mV/mA (typical), and not more than 100 ppm/ $^{\circ}\text{C}$  of drift. Only the 14-pin package allows external access to reference voltages, where voltages of 1.2 V and 0.6 V are both available. Output current versus output voltage is illustrated in the [Typical Characteristics](#) section.

## 8 Application and Implementation

### Note

以下应用部分中的信息不属于 TI 器件规格的范围，TI 不担保其准确性和完整性。TI 的客户应负责确定器件是否适用于其应用。客户应验证并测试其设计，以确保系统功能。

### 8.1 Application Information

The INA203, INA204, and INA205 series is designed to enable easy configuration for detecting overcurrent conditions and current monitoring in an application. This device is also incorporate two open-drain comparators with internal 0.6-V references. On 14-pin versions, the comparator references can be overridden by external inputs. Comparator 1 includes a latching capability, and Comparator 2 has a user-programmable delay. 14-pin versions also provide a 1.2-V reference output. This device can also be paired with minimum additional devices to create more sophisticated monitoring functional blocks.

### 8.2 Typical Application

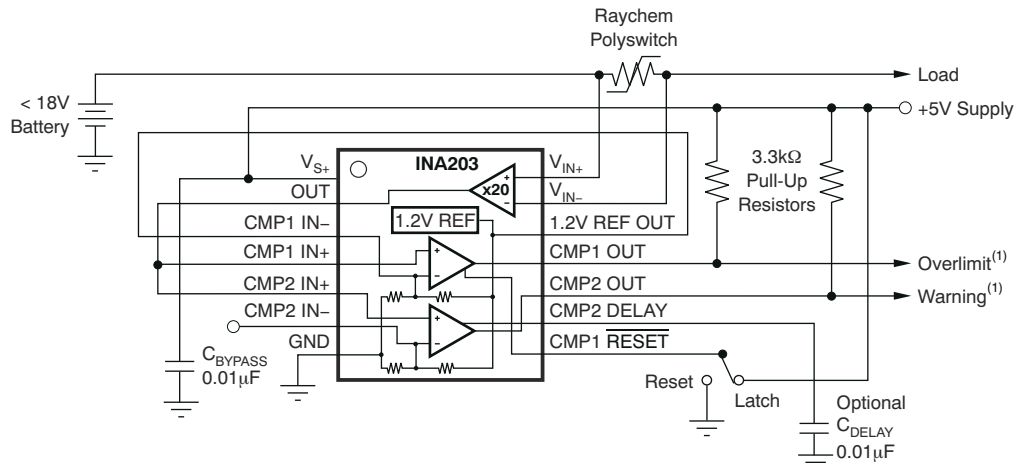

NOTE: (1) Warning at half current (with optional delay). Overlimit latches when Polyswitch opens.

图 8-1. Polyswitch Warning and Fault Detection Circuit

#### 8.2.1 Design Requirements

The device measures current through a resistive shunt with current flowing in one direction, thus enabling detection of an overlimit or warning event only when the differential input voltage exceeds the corresponding threshold limits. When the current reaches the warning limit of 0.6 V, the output of CMP2 will transition high indicating a warning condition. When the current further increases to or past the overlimit limit of 1.2 V, the output of CMP1 will transition high indicating an overlimit condition. Optional  $C_{DELAY}$  can be sized to add delay to CMP1.

#### 8.2.2 Detailed Design Procedure

图 8-1 shows the basic connections of the device. The input terminals,  $IN+$  and  $IN-$ , should be connected as closely as possible to the current-sensing resistor or polymeric switch to minimize any resistance in series with the shunt resistance. Additional resistance between the current-sensing resistor and input terminals can result in errors in the measurement. When input current flows through this external input resistance, the voltage developed across the shunt resistor can differ from the voltage reaching the input terminals.

### 8.2.3 Application Curves

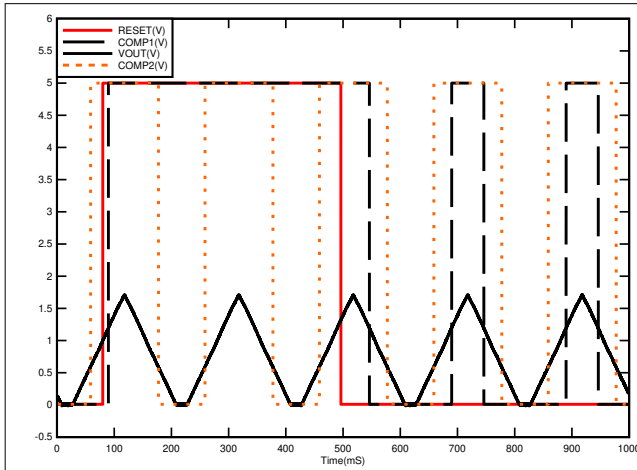

**图 8-2. Polyswitch Warning and Fault Detection Circuit Response**

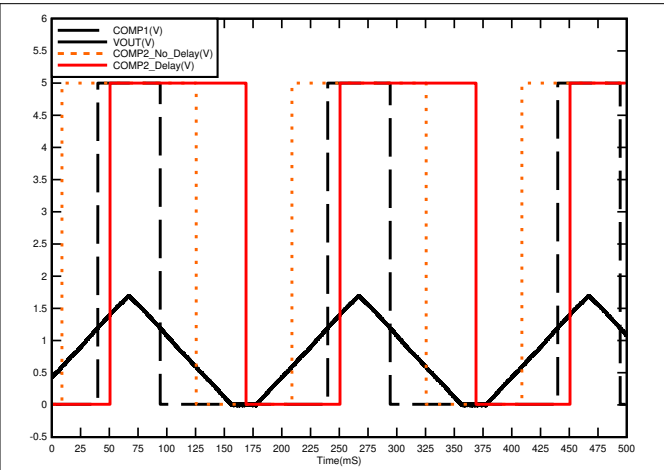

**图 8-3. Polyswitch Warning and Fault Detection Circuit With Delay Response**

## 9 Power Supply Recommendations

The input circuitry of the INA203, INA204, and INA205 can accurately measure beyond the power-supply voltage,  $V_S$ . For example, the  $V_S$  power supply can be 5 V, whereas the load power-supply voltage is up to 80 V. The output voltage range of the OUT terminal, however, is limited by the voltages on the power-supply pin.

## 10 Layout

### 10.1 Layout Guidelines

- Connect the input pins to the sensing resistor using a Kelvin or 4-wire connection. This connection technique ensures that only the current-sensing resistor impedance is detected between the input pins. Poor routing of the current-sensing resistor commonly results in additional resistance present between the input pins. Given the very low ohmic value of the current resistor, any additional high-current carrying impedance can cause significant measurement errors.
- The power-supply bypass capacitor should be placed as closely as possible to the supply and ground pins. The recommended value of this bypass capacitor is 0.1  $\mu$ F. Additional decoupling capacitance can be added to compensate for noisy or high-impedance power supplies.

### 10.2 Layout Example



图 10-1. Layout Recommendation



## 11 Device and Documentation Support

### 11.1 Related Links

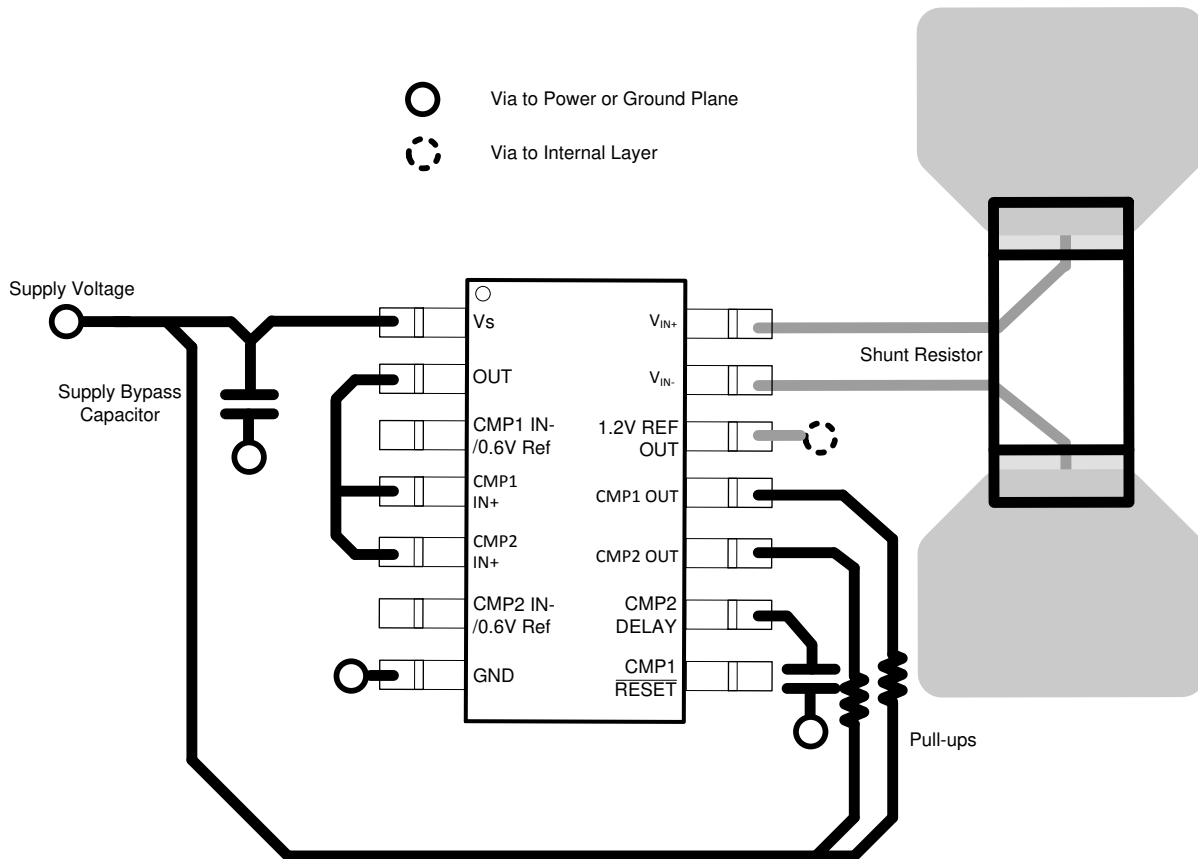
The table below lists quick access links. Categories include technical documents, support and community resources, tools and software, and quick access to sample or buy.

**表 11-1. Related Links**

PARTS	PRODUCT FOLDER	SAMPLE & BUY	TECHNICAL DOCUMENTS	TOOLS & SOFTWARE	SUPPORT & COMMUNITY
INA203	<a href="#">Click here</a>	<a href="#">Click here</a>	<a href="#">Click here</a>	<a href="#">Click here</a>	<a href="#">Click here</a>
INA204	<a href="#">Click here</a>	<a href="#">Click here</a>	<a href="#">Click here</a>	<a href="#">Click here</a>	<a href="#">Click here</a>
INA205	<a href="#">Click here</a>	<a href="#">Click here</a>	<a href="#">Click here</a>	<a href="#">Click here</a>	<a href="#">Click here</a>

### 11.2 接收文档更新通知

要接收文档更新通知，请导航至 [ti.com](http://ti.com) 上的器件产品文件夹。点击 [订阅更新](#) 进行注册，即可每周接收产品信息更改摘要。有关更改的详细信息，请查看任何已修订文档中包含的修订历史记录。

### 11.3 支持资源

**TI E2E™ 支持论坛**是工程师的重要参考资料，可直接从专家获得快速、经过验证的解答和设计帮助。搜索现有解答或提出自己的问题可获得所需的快速设计帮助。

链接的内容由各个贡献者“按原样”提供。这些内容并不构成 TI 技术规范，并且不一定反映 TI 的观点；请参阅 TI 的《[使用条款](#)》。

### 11.4 Trademarks

TI E2E™ is a trademark of Texas Instruments.

所有商标均为其各自所有者的财产。

### 11.5 Electrostatic Discharge Caution



This integrated circuit can be damaged by ESD. Texas Instruments recommends that all integrated circuits be handled with appropriate precautions. Failure to observe proper handling and installation procedures can cause damage.

ESD damage can range from subtle performance degradation to complete device failure. Precision integrated circuits may be more susceptible to damage because very small parametric changes could cause the device not to meet its published specifications.

### 11.6 术语表

**TI 术语表** 本术语表列出并解释了术语、首字母缩略词和定义。

## 12 Mechanical, Packaging, and Orderable Information

The following pages include mechanical, packaging, and orderable information. This information is the most current data available for the designated devices. This data is subject to change without notice and revision of this document. For browser-based versions of this data sheet, refer to the left-hand navigation.

## 重要声明和免责声明

TI 提供技术和可靠性数据 (包括数据表)、设计资源 (包括参考设计)、应用或其他设计建议、网络工具、安全信息和其他资源, 不保证没有瑕疵且不做任何明示或暗示的担保, 包括但不限于对适销性、某特定用途方面的适用性或不侵犯任何第三方知识产权的暗示担保。

这些资源可供使用 TI 产品进行设计的熟练开发人员使用。您将自行承担以下全部责任: (1) 针对您的应用选择合适的 TI 产品, (2) 设计、验证并测试您的应用, (3) 确保您的应用满足相应标准以及任何其他安全、安保或其他要求。这些资源如有变更, 恕不另行通知。TI 授权您仅可将这些资源用于研发本资源所述的 TI 产品的应用。严禁对这些资源进行其他复制或展示。您无权使用任何其他 TI 知识产权或任何第三方知识产权。您应全额赔偿因在这些资源的使用中对 TI 及其代表造成的任何索赔、损害、成本、损失和债务, TI 对此概不负责。

TI 提供的产品受 TI 的销售条款 (<https://www.ti.com/legal/termsofsale.html>) 或 [ti.com](https://www.ti.com) 上其他适用条款/TI 产品随附的其他适用条款的约束。TI 提供这些资源并不会扩展或以其他方式更改 TI 针对 TI 产品发布的适用的担保或担保免责声明。

邮寄地址: Texas Instruments, Post Office Box 655303, Dallas, Texas 75265  
Copyright © 2021, 德州仪器 (TI) 公司

**PACKAGING INFORMATION**

Orderable part number	Status (1)	Material type (2)	Package   Pins	Package qty   Carrier	RoHS (3)	Lead finish/ Ball material (4)	MSL rating/ Peak reflow (5)	Op temp (°C)	Part marking (6)
<a href="#">INA203AID</a>	Obsolete	Production	SOIC (D)   14	-	-	Call TI	Call TI	-40 to 125	INA203A
<a href="#">INA203AIDGSR</a>	Active	Production	VSSOP (DGS)   10	2500   LARGE T&R	Yes	Call TI	Level-2-260C-1 YEAR	-40 to 125	BQN
INA203AIDGSR.A	Active	Production	VSSOP (DGS)   10	2500   LARGE T&R	Yes	Call TI	Level-2-260C-1 YEAR	-40 to 125	BQN
INA203AIDGSR.B	Active	Production	VSSOP (DGS)   10	2500   LARGE T&R	Yes	Call TI	Level-2-260C-1 YEAR	-40 to 125	BQN
<a href="#">INA203AIDGST</a>	Obsolete	Production	VSSOP (DGS)   10	-	-	Call TI	Call TI	-40 to 125	BQN
<a href="#">INA203AIDR</a>	Active	Production	SOIC (D)   14	2500   LARGE T&R	Yes	NIPDAU	Level-2-260C-1 YEAR	-40 to 125	INA203A
INA203AIDR.A	Active	Production	SOIC (D)   14	2500   LARGE T&R	Yes	NIPDAU	Level-2-260C-1 YEAR	-40 to 125	INA203A
INA203AIDR.B	Active	Production	SOIC (D)   14	2500   LARGE T&R	Yes	NIPDAU	Level-2-260C-1 YEAR	-40 to 125	INA203A
<a href="#">INA203AIPW</a>	Obsolete	Production	TSSOP (PW)   14	-	-	Call TI	Call TI	-40 to 125	INA203A
<a href="#">INA203AIPWR</a>	Active	Production	TSSOP (PW)   14	2000   LARGE T&R	Yes	NIPDAU	Level-2-260C-1 YEAR	-40 to 125	INA203A
INA203AIPWR.A	Active	Production	TSSOP (PW)   14	2000   LARGE T&R	Yes	NIPDAU	Level-2-260C-1 YEAR	-40 to 125	INA203A
INA203AIPWR.B	Active	Production	TSSOP (PW)   14	2000   LARGE T&R	Yes	NIPDAU	Level-2-260C-1 YEAR	-40 to 125	INA203A
<a href="#">INA204AID</a>	Obsolete	Production	SOIC (D)   14	-	-	Call TI	Call TI	-40 to 125	INA204A
<a href="#">INA204AIDGSR</a>	Active	Production	VSSOP (DGS)   10	2500   LARGE T&R	Yes	Call TI	Level-2-260C-1 YEAR	-40 to 125	BQO
INA204AIDGSR.A	Active	Production	VSSOP (DGS)   10	2500   LARGE T&R	Yes	Call TI	Level-2-260C-1 YEAR	-40 to 125	BQO
INA204AIDGSR.B	Active	Production	VSSOP (DGS)   10	2500   LARGE T&R	Yes	Call TI	Level-2-260C-1 YEAR	-40 to 125	BQO
<a href="#">INA204AIDGST</a>	Obsolete	Production	VSSOP (DGS)   10	-	-	Call TI	Call TI	-40 to 125	BQO
<a href="#">INA204AIDR</a>	Active	Production	SOIC (D)   14	2500   LARGE T&R	Yes	NIPDAU	Level-2-260C-1 YEAR	-40 to 125	INA204A
INA204AIDR.A	Active	Production	SOIC (D)   14	2500   LARGE T&R	Yes	NIPDAU	Level-2-260C-1 YEAR	-40 to 125	INA204A
INA204AIDR.B	Active	Production	SOIC (D)   14	2500   LARGE T&R	Yes	NIPDAU	Level-2-260C-1 YEAR	-40 to 125	INA204A
<a href="#">INA205AID</a>	Obsolete	Production	SOIC (D)   14	-	-	Call TI	Call TI	-40 to 125	INA205A
<a href="#">INA205AIDGSR</a>	Active	Production	VSSOP (DGS)   10	2500   LARGE T&R	Yes	Call TI	Level-2-260C-1 YEAR	-40 to 125	BQP
INA205AIDGSR.A	Active	Production	VSSOP (DGS)   10	2500   LARGE T&R	Yes	Call TI	Level-2-260C-1 YEAR	-40 to 125	BQP
INA205AIDGSR.B	Active	Production	VSSOP (DGS)   10	2500   LARGE T&R	Yes	Call TI	Level-2-260C-1 YEAR	-40 to 125	BQP
<a href="#">INA205AIDGST</a>	Obsolete	Production	VSSOP (DGS)   10	-	-	Call TI	Call TI	-40 to 125	BQP
<a href="#">INA205AIDR</a>	Active	Production	SOIC (D)   14	2500   LARGE T&R	Yes	NIPDAU	Level-2-260C-1 YEAR	-40 to 125	INA205A
INA205AIDR.A	Active	Production	SOIC (D)   14	2500   LARGE T&R	Yes	NIPDAU	Level-2-260C-1 YEAR	-40 to 125	INA205A
INA205AIDR.B	Active	Production	SOIC (D)   14	2500   LARGE T&R	Yes	NIPDAU	Level-2-260C-1 YEAR	-40 to 125	INA205A
<a href="#">INA205AIPW</a>	Obsolete	Production	TSSOP (PW)   14	-	-	Call TI	Call TI	-40 to 125	INA205A

Orderable part number	Status (1)	Material type (2)	Package   Pins	Package qty   Carrier	RoHS (3)	Lead finish/ Ball material (4)	MSL rating/ Peak reflow (5)	Op temp (°C)	Part marking (6)
<a href="#">INA205AIPWR</a>	Active	Production	TSSOP (PW)   14	2000   LARGE T&R	Yes	NIPDAU	Level-2-260C-1 YEAR	-40 to 125	INA205A
INA205AIPWR.A	Active	Production	TSSOP (PW)   14	2000   LARGE T&R	Yes	NIPDAU	Level-2-260C-1 YEAR	-40 to 125	INA205A
INA205AIPWR.B	Active	Production	TSSOP (PW)   14	2000   LARGE T&R	Yes	NIPDAU	Level-2-260C-1 YEAR	-40 to 125	INA205A

(1) **Status:** For more details on status, see our [product life cycle](#).

(2) **Material type:** When designated, preproduction parts are prototypes/experimental devices, and are not yet approved or released for full production. Testing and final process, including without limitation quality assurance, reliability performance testing, and/or process qualification, may not yet be complete, and this item is subject to further changes or possible discontinuation. If available for ordering, purchases will be subject to an additional waiver at checkout, and are intended for early internal evaluation purposes only. These items are sold without warranties of any kind.

(3) **RoHS values:** Yes, No, RoHS Exempt. See the [TI RoHS Statement](#) for additional information and value definition.

(4) **Lead finish/Ball material:** Parts may have multiple material finish options. Finish options are separated by a vertical ruled line. Lead finish/Ball material values may wrap to two lines if the finish value exceeds the maximum column width.

(5) **MSL rating/Peak reflow:** The moisture sensitivity level ratings and peak solder (reflow) temperatures. In the event that a part has multiple moisture sensitivity ratings, only the lowest level per JEDEC standards is shown. Refer to the shipping label for the actual reflow temperature that will be used to mount the part to the printed circuit board.

(6) **Part marking:** There may be an additional marking, which relates to the logo, the lot trace code information, or the environmental category of the part.

Multiple part markings will be inside parentheses. Only one part marking contained in parentheses and separated by a "-" will appear on a part. If a line is indented then it is a continuation of the previous line and the two combined represent the entire part marking for that device.

**Important Information and Disclaimer:** The information provided on this page represents TI's knowledge and belief as of the date that it is provided. TI bases its knowledge and belief on information provided by third parties, and makes no representation or warranty as to the accuracy of such information. Efforts are underway to better integrate information from third parties. TI has taken and continues to take reasonable steps to provide representative and accurate information but may not have conducted destructive testing or chemical analysis on incoming materials and chemicals. TI and TI suppliers consider certain information to be proprietary, and thus CAS numbers and other limited information may not be available for release.

In no event shall TI's liability arising out of such information exceed the total purchase price of the TI part(s) at issue in this document sold by TI to Customer on an annual basis.

**OTHER QUALIFIED VERSIONS OF INA203 :**

- Automotive : [INA203-Q1](#)

NOTE: Qualified Version Definitions:

- Automotive - Q100 devices qualified for high-reliability automotive applications targeting zero defects

**TAPE AND REEL INFORMATION**

**QUADRANT ASSIGNMENTS FOR PIN 1 ORIENTATION IN TAPE**

\*All dimensions are nominal

Device	Package Type	Package Drawing	Pins	SPQ	Reel Diameter (mm)	Reel Width W1 (mm)	A0 (mm)	B0 (mm)	K0 (mm)	P1 (mm)	W (mm)	Pin1 Quadrant
INA203AIDR	SOIC	D	14	2500	330.0	16.4	6.5	9.0	2.1	8.0	16.0	Q1
INA203AIPWR	TSSOP	PW	14	2000	330.0	12.4	6.9	5.6	1.6	8.0	12.0	Q1
INA204AIDR	SOIC	D	14	2500	330.0	16.4	6.5	9.0	2.1	8.0	16.0	Q1
INA205AIDGSR	VSSOP	DGS	10	2500	330.0	12.4	5.3	3.4	1.4	8.0	12.0	Q1
INA205AIDR	SOIC	D	14	2500	330.0	16.4	6.5	9.0	2.1	8.0	16.0	Q1
INA205AIPWR	TSSOP	PW	14	2000	330.0	12.4	6.9	5.6	1.6	8.0	12.0	Q1

## TAPE AND REEL BOX DIMENSIONS



\*All dimensions are nominal

Device	Package Type	Package Drawing	Pins	SPQ	Length (mm)	Width (mm)	Height (mm)
INA203AIDR	SOIC	D	14	2500	353.0	353.0	32.0
INA203AIPWR	TSSOP	PW	14	2000	353.0	353.0	32.0
INA204AIDR	SOIC	D	14	2500	353.0	353.0	32.0
INA205AIDGSR	VSSOP	DGS	10	2500	353.0	353.0	32.0
INA205AIDR	SOIC	D	14	2500	353.0	353.0	32.0
INA205AIPWR	TSSOP	PW	14	2000	353.0	353.0	32.0

**TUBE**

\*All dimensions are nominal

Device	Package Name	Package Type	Pins	SPQ	L (mm)	W (mm)	T (μm)	B (mm)
INA203AIDGSR	DGS	VSSOP	10	2500	274	6.55	500	2.88
INA203AIDGSR.A	DGS	VSSOP	10	2500	274	6.55	500	2.88
INA203AIDGSR.B	DGS	VSSOP	10	2500	274	6.55	500	2.88
INA204AIDGSR	DGS	VSSOP	10	2500	274	6.55	500	2.88
INA204AIDGSR.A	DGS	VSSOP	10	2500	274	6.55	500	2.88
INA204AIDGSR.B	DGS	VSSOP	10	2500	274	6.55	500	2.88
INA205AIDGSR	DGS	VSSOP	10	2500	274	6.55	500	2.88
INA205AIDGSR.A	DGS	VSSOP	10	2500	274	6.55	500	2.88
INA205AIDGSR.B	DGS	VSSOP	10	2500	274	6.55	500	2.88





# D0014A

# PACKAGE OUTLINE

## SOIC - 1.75 mm max height

SMALL OUTLINE INTEGRATED CIRCUIT



4220718/A 09/2016

### NOTES:

1. All linear dimensions are in millimeters. Dimensions in parenthesis are for reference only. Dimensioning and tolerancing per ASME Y14.5M.
2. This drawing is subject to change without notice.
3. This dimension does not include mold flash, protrusions, or gate burrs. Mold flash, protrusions, or gate burrs shall not exceed 0.15 mm, per side.
4. This dimension does not include interlead flash. Interlead flash shall not exceed 0.43 mm, per side.
5. Reference JEDEC registration MS-012, variation AB.

# EXAMPLE BOARD LAYOUT

D0014A

SOIC - 1.75 mm max height

SMALL OUTLINE INTEGRATED CIRCUIT



LAND PATTERN EXAMPLE  
SCALE:8X



SOLDER MASK DETAILS

4220718/A 09/2016

NOTES: (continued)

- 6. Publication IPC-7351 may have alternate designs.
- 7. Solder mask tolerances between and around signal pads can vary based on board fabrication site.

# EXAMPLE STENCIL DESIGN

D0014A

SOIC - 1.75 mm max height

SMALL OUTLINE INTEGRATED CIRCUIT



SOLDER PASTE EXAMPLE  
BASED ON 0.125 mm THICK STENCIL  
SCALE:8X

4220718/A 09/2016

NOTES: (continued)

8. Laser cutting apertures with trapezoidal walls and rounded corners may offer better paste release. IPC-7525 may have alternate design recommendations.
9. Board assembly site may have different recommendations for stencil design.

# DGS0010A



# PACKAGE OUTLINE

## VSSOP - 1.1 mm max height

SMALL OUTLINE PACKAGE



4221984/A 05/2015

### NOTES:

1. All linear dimensions are in millimeters. Any dimensions in parenthesis are for reference only. Dimensioning and tolerancing per ASME Y14.5M.
2. This drawing is subject to change without notice.
3. This dimension does not include mold flash, protrusions, or gate burrs. Mold flash, protrusions, or gate burrs shall not exceed 0.15 mm per side.
4. This dimension does not include interlead flash. Interlead flash shall not exceed 0.25 mm per side.
5. Reference JEDEC registration MO-187, variation BA.

# EXAMPLE BOARD LAYOUT

DGS0010A

VSSOP - 1.1 mm max height

SMALL OUTLINE PACKAGE



LAND PATTERN EXAMPLE  
SCALE:10X

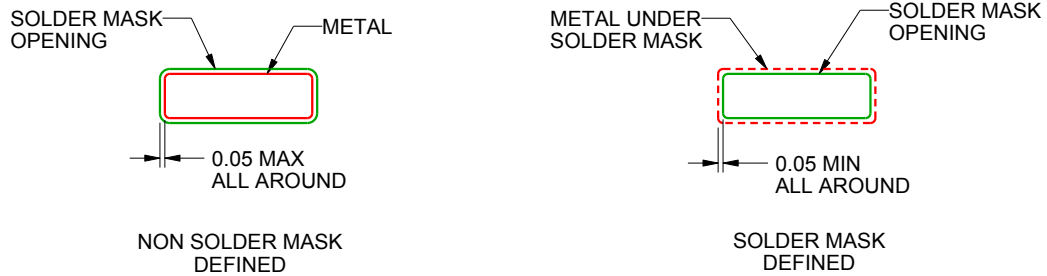

SOLDER MASK DETAILS  
NOT TO SCALE

4221984/A 05/2015

NOTES: (continued)

6. Publication IPC-7351 may have alternate designs.
7. Solder mask tolerances between and around signal pads can vary based on board fabrication site.

# EXAMPLE STENCIL DESIGN

DGS0010A

VSSOP - 1.1 mm max height

SMALL OUTLINE PACKAGE



SOLDER PASTE EXAMPLE  
BASED ON 0.125 mm THICK STENCIL  
SCALE:10X

4221984/A 05/2015

NOTES: (continued)

8. Laser cutting apertures with trapezoidal walls and rounded corners may offer better paste release. IPC-7525 may have alternate design recommendations.
9. Board assembly site may have different recommendations for stencil design.

PW0014A



PACKAGE OUTLINE

TSSOP - 1.2 mm max height

SMALL OUTLINE PACKAGE

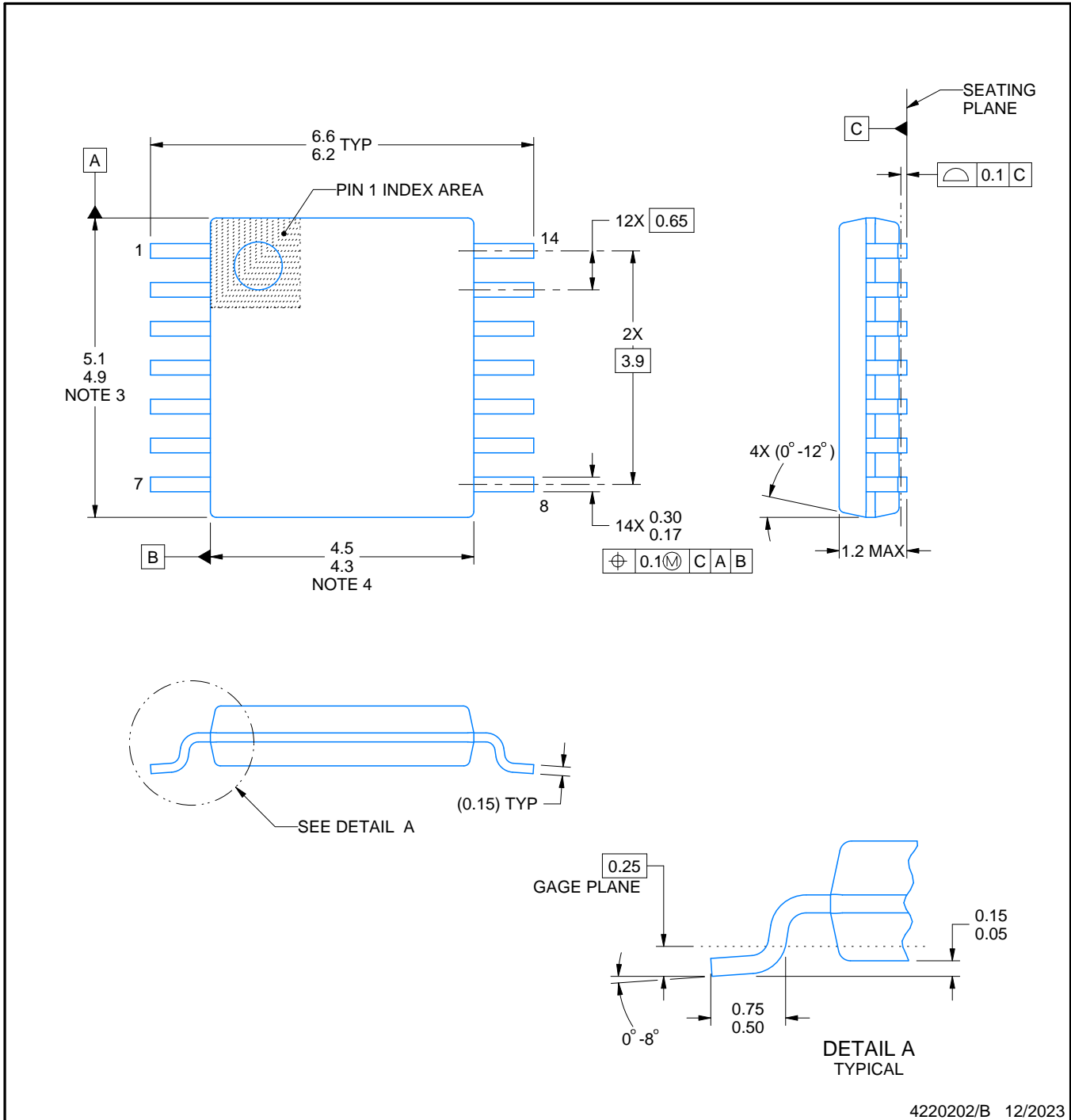

4220202/B 12/2023

NOTES:

1. All linear dimensions are in millimeters. Any dimensions in parenthesis are for reference only. Dimensioning and tolerancing per ASME Y14.5M.
2. This drawing is subject to change without notice.
3. This dimension does not include mold flash, protrusions, or gate burrs. Mold flash, protrusions, or gate burrs shall not exceed 0.15 mm per side.
4. This dimension does not include interlead flash. Interlead flash shall not exceed 0.25 mm per side.
5. Reference JEDEC registration MO-153.

# EXAMPLE BOARD LAYOUT

PW0014A

TSSOP - 1.2 mm max height

SMALL OUTLINE PACKAGE



LAND PATTERN EXAMPLE  
EXPOSED METAL SHOWN  
SCALE: 10X



4220202/B 12/2023

NOTES: (continued)

- 6. Publication IPC-7351 may have alternate designs.
- 7. Solder mask tolerances between and around signal pads can vary based on board fabrication site.



# EXAMPLE STENCIL DESIGN

PW0014A

TSSOP - 1.2 mm max height

SMALL OUTLINE PACKAGE



SOLDER PASTE EXAMPLE  
BASED ON 0.125 mm THICK STENCIL  
SCALE: 10X

4220202/B 12/2023

NOTES: (continued)

8. Laser cutting apertures with trapezoidal walls and rounded corners may offer better paste release. IPC-7525 may have alternate design recommendations.
9. Board assembly site may have different recommendations for stencil design.

## 重要通知和免责声明

TI“按原样”提供技术和可靠性数据（包括数据表）、设计资源（包括参考设计）、应用或其他设计建议、网络工具、安全信息和其他资源，不保证没有瑕疵且不做任何明示或暗示的担保，包括但不限于对适销性、与某特定用途的适用性或不侵犯任何第三方知识产权的暗示担保。

这些资源可供使用 TI 产品进行设计的熟练开发人员使用。您将自行承担以下全部责任：(1) 针对您的应用选择合适的 TI 产品，(2) 设计、验证并测试您的应用，(3) 确保您的应用满足相应标准以及任何其他安全、安保法规或其他要求。

这些资源如有变更，恕不另行通知。TI 授权您仅可将这些资源用于研发本资源所述的 TI 产品的相关应用。严禁以其他方式对这些资源进行复制或展示。您无权使用任何其他 TI 知识产权或任何第三方知识产权。对于因您对这些资源的使用而对 TI 及其代表造成的任何索赔、损害、成本、损失和债务，您将全额赔偿，TI 对此概不负责。

TI 提供的产品受 [TI 销售条款](#)、[TI 通用质量指南](#) 或 [ti.com](#) 上其他适用条款或 TI 产品随附的其他适用条款的约束。TI 提供这些资源并不会扩展或以其他方式更改 TI 针对 TI 产品发布的适用的担保或担保免责声明。除非德州仪器 (TI) 明确将某产品指定为定制产品或客户特定产品，否则其产品均为按确定价格收入目录的标准通用器件。

TI 反对并拒绝您可能提出的任何其他或不同的条款。

版权所有 © 2026，德州仪器 (TI) 公司

最后更新日期：2025 年 10 月