

## HDC1008 具有温度传感器的低功耗、高精度数字湿度传感器

### 1 特性

- 相对湿度 (RH) 工作范围为 0% 至 100%
- 14 位测量分辨率
- 相对湿度精度为  $\pm 4\%$
- 温度范围
  - 工作温度为  $-20^{\circ}\text{C}$  至  $85^{\circ}\text{C}$
  - 可检测温度为  $-40^{\circ}\text{C}$  至  $125^{\circ}\text{C}$
- 温度精度为  $\pm 0.2^{\circ}\text{C}$
- 休眠模式电流为 200nA
- 平均电源电流:
  - 1sps、11 位 RH 测量时为 820nA
  - 1sps、11 位 RH 与温度测量时为  $1.2\mu\text{A}$
- 电源电压 3V 至 5V
- 微型 2mm x 1.6mm 器件封装
- I<sup>2</sup>C 接口

### 2 应用

- 制热、通风与空调控制 (HVAC)
- 智能温度调节装置和室温监视器
- 大型家用电器
- 打印机
- 手持式计量表
- 医疗设备
- 货物运输
- 汽车挡风玻璃除雾装置
- 穿戴式设备
- 移动设备

### 3 说明

HDC1008 是一款具有集成温度传感器的数字湿度传感器，其能够以超低功耗提供出色的测量精度。该器件基于新型电容式传感器来测量湿度。湿度和温度传感器均经过出厂校准。创新型 WLCSP（晶圆级芯片规模封装）凭借超紧凑型封装简化了电路板设计。

HDC1008 的传感元件位于器件底部，这样可使 HDC1008 免受灰尘、粉尘以及其它环境污染物的影响，从而提高耐用性。HDC1008 可在整个  $-40^{\circ}\text{C}$  至  $+125^{\circ}\text{C}$  温度范围内进行检测。

器件信息 (1)

| 部件号     | 封装           | 封装尺寸 (标称值)      |
|---------|--------------|-----------------|
| HDC1008 | DSBGA (8 凸点) | 2.04mm x 1.59mm |

(1) 要了解所有可用封装，请见数据表末尾的可订购产品附录。

### 4 典型应用

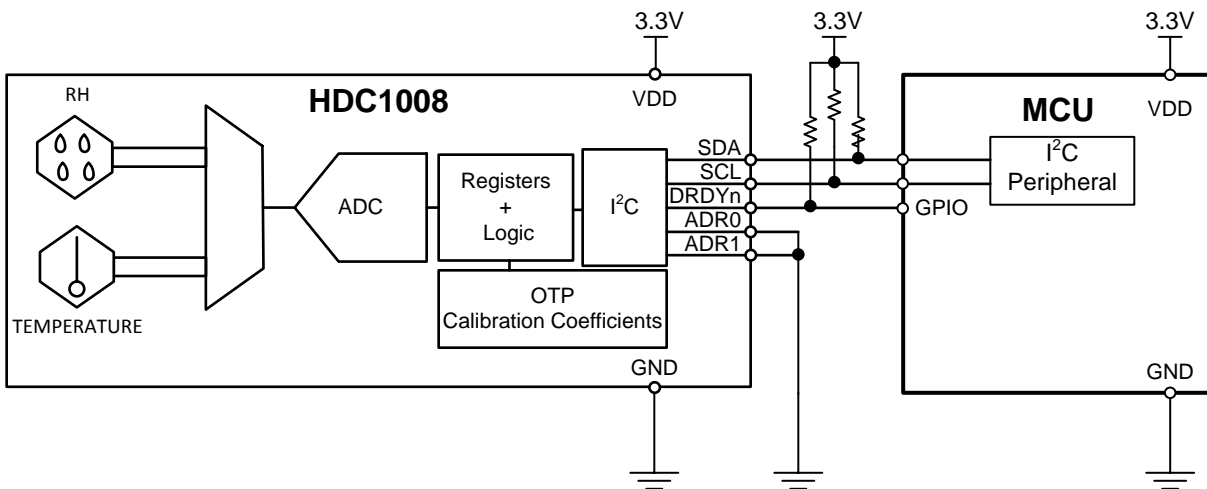

## 目录

|          |   |          |           |   |           |
|----------|---|----------|-----------|---|-----------|
| <b>1</b> | 特性 .....  | <b>1</b> | 8.3       | Feature Description .....                   | <b>9</b>  |
| <b>2</b> | 应用 .....  | <b>1</b> | 8.4       | Device Functional Modes .....               | <b>9</b>  |
| <b>3</b> | 说明 .....  | <b>1</b> | 8.5       | Programming .....                           | <b>10</b> |
| <b>4</b> | 典型应用 .....  | <b>1</b> | 8.6       | Register Map .....                          | <b>14</b> |
| <b>5</b> | 修订历史记录 .....  | <b>2</b> | <b>9</b>  | <b>Application and Implementation</b> ..... | <b>16</b> |
| <b>6</b> | <b>Pin Configuration and Functions</b> .....                | <b>3</b> | 9.1       | Application Information .....               | <b>16</b> |
| <b>7</b> | <b>Specifications</b> .....                                 | <b>4</b> | 9.2       | Typical Application .....                   | <b>16</b> |
| 7.1      | Absolute Maximum Ratings .....                              | <b>4</b> | 9.3       | Do's and Don'ts .....                       | <b>18</b> |
| 7.2      | Handling Ratings .....                                      | <b>4</b> | <b>10</b> | <b>Power Supply Recommendations</b> .....   | <b>18</b> |
| 7.3      | Recommended Operating Conditions .....                      | <b>4</b> | <b>11</b> | <b>Layout</b> .....                         | <b>19</b> |
| 7.4      | Thermal Information .....                                   | <b>4</b> | 11.1      | Layout Guidelines .....                     | <b>19</b> |
| 7.5      | Electrical Characteristics .....                            | <b>5</b> | 11.2      | Layout Example .....                        | <b>21</b> |
| 7.6      | I <sup>2</sup> C Interface Electrical Characteristics ..... | <b>6</b> | <b>12</b> | 器件和文档支持 .....                               | <b>22</b> |
| 7.7      | I <sup>2</sup> C Interface Timing Requirements .....        | <b>6</b> | 12.1      | 文档支持 .....                                  | <b>22</b> |
| 7.8      | Typical Characteristics .....                               | <b>7</b> | 12.2      | 商标 .....                                    | <b>22</b> |
| <b>8</b> | <b>Detailed Description</b> .....                           | <b>9</b> | 12.3      | 静电放电警告 .....                                | <b>22</b> |
| 8.1      | Overview .....  | <b>9</b> | 12.4      | 术语表 .....                                   | <b>22</b> |
| 8.2      | Functional Block Diagram .....                              | <b>9</b> | <b>13</b> | 机械封装和可订购信息 .....                            | <b>22</b> |

## 5 修订历史记录

### Changes from Original (October 2014) to Revision A

**Page**

|   |           |
|---|-----------|
| • 已更改 数据表的标题 .....                      | <b>1</b>  |
| • 已更改 说明 .....                          | <b>1</b>  |
| • Changed overview .....                | <b>9</b>  |
| • Changed application information ..... | <b>16</b> |
| • Changed recovery from soldering ..... | <b>18</b> |

## 6 Pin Configuration and Functions

**WLCSP (DSBGA)  
8 Pin  
Top View**

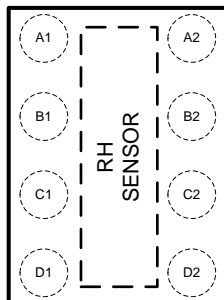

**Pin Functions**

| PIN               |     | I/O TYPE <sup>(1)</sup> | DESCRIPTION   |
|-------------------|-----|-------------------------|---|
| NAME              | NO. |                         |   |
| SCL               | A1  | I                       | Serial clock line for I <sup>2</sup> C, open-drain; requires a pull-up resistor to VDD                        |
| VDD               | B1  | P                       | Supply Voltage  |
| ADR0              | C1  | I                       | Address select pin – hardwired to GND or VDD  |
| ADR1              | D1  | I                       | Address select pin – hardwired to GND or VDD  |
| SDA               | A2  | I/O                     | Serial data line for I <sup>2</sup> C, open-drain; requires a pull-up resistor to VDD                         |
| GND               | B2  | G                       | Ground  |
| DNC               | C2  | -                       | Do Not Connect or connect to GND  |
| DRDY <sub>n</sub> | D2  | O                       | Data ready, active low, open-drain; requires a pull-up resistor to VDD. If not used tie to GND or no connect. |

(1) P=Power, G=Ground, I=Input, O=Output

## 7 Specifications

### 7.1 Absolute Maximum Ratings<sup>(1)</sup>

|               |       | MIN  | MAX     | UNIT |
|---------------|-------|------|---------|------|
| Input Voltage | VDD   | -0.3 | 6       | V    |
|               | SCL   | -0.3 | 6       |      |
|               | SDA   | -0.3 | 6       |      |
|               | DRDYn | -0.3 | 6       |      |
|               | ADR0  | -0.3 | VDD+0.3 |      |
|               | ADR1  | -0.3 | VDD+0.3 |      |

- (1) Stresses beyond those listed under *Absolute Maximum Ratings* may cause permanent damage to the device. These are stress ratings only, which do not imply functional operation of the device at these or any other conditions beyond those indicated under *Recommended Operating Conditions*. Exposure to absolute-maximum-rated conditions for extended periods may affect device reliability.

### 7.2 Handling Ratings

|                    |                                    |   | MIN   | MAX  | UNIT |
|--------------------|------------------------------------|---|-------|------|------|
| T <sub>STG</sub>   | Storage Temperature <sup>(1)</sup> |   | -65   | 150  | °C   |
| V <sub>(ESD)</sub> | Electrostatic discharge            | Human body model (HBM), per ANSI/ESDA/JEDEC JS-001, all pins <sup>(2)</sup>                       | -1000 | 1000 | V    |
|                    |                                    | Charged device model (CDM), per JEDEC specification –500 500 JESD22-C101, all pins <sup>(3)</sup> | -250  | 250  |      |

- (1) For long term storage, it is recommended to stay within 10%RH-80%RH and +5°C to 60°C. Storage beyond this range may result in a temporary RH offset shift.
- (2) JEDEC document JEP155 states that 500-V HBM allows safe manufacturing with a standard ESD control process.
- (3) JEDEC document JEP157 states that 250-V CDM allows safe manufacturing with a standard ESD control process.

### 7.3 Recommended Operating Conditions

over operating range (unless otherwise noted)

|                 |                               | MIN | NOM | MAX | UNIT |
|-----------------|-------------------------------|-----|-----|-----|------|
| V <sub>DD</sub> | Supply Voltage                | 2.7 | 3   | 5.5 | V    |
| T <sub>A</sub>  | Ambient Operating Temperature | -40 |     | 125 | °C   |

### 7.4 Thermal Information

| THERMAL METRIC <sup>(1)</sup> |  | HDC1008 | UNIT |
|-------------------------------|--|---------|------|
|                               |  | DSBGA   |      |
|                               |  | 8 PINS  |      |
| R <sub>θJA</sub>              | Junction-to-Ambient Thermal Resistance | 98.0    | °C/W |

- (1) For more information about traditional and new thermal metrics, see the: *IC Package Thermal Metrics* application report, [SPRA953](#).

## 7.5 Electrical Characteristics

The electrical ratings specified in this section apply to all specifications in this document, unless otherwise noted.  $T_A = 30^\circ\text{C}$ ,  $V_{DD} = 3\text{V}$ .

| PARAMETER                       |                                | TEST CONDITION  | MIN | TYP       | MAX       | UNIT             |
|---------------------------------|--------------------------------|---|-----|-----------|-----------|------------------|
| <b>POWER CONSUMPTION</b>        |                                |   |     |           |           |                  |
| $I_{DD}$                        | Supply Current                 | RH measurement, bit 12 of 0x02 register = 0 <sup>(1)</sup>  |     | 180       | 220       | $\mu\text{A}$    |
|                                 |                                | Temperature measurement, bit 12 of 0x02 register = 0 <sup>(1)</sup>   |     | 155       | 185       | $\mu\text{A}$    |
|                                 |                                | Sleep Mode  |     | 110       | 200       | nA               |
|                                 |                                | Average @ 1 measurement/second, RH (11 bit), bit 12 of 0x02 register = 0 <sup>(1)(2)</sup>                      |     | 730       |           | nA               |
|                                 |                                | Average @ 1 measurement/second, Temp (11 bit), bit 12 of 0x02 register = 0 <sup>(1)(2)</sup>                    |     | 580       |           | nA               |
|                                 |                                | Average @ 1 measurement/second, RH (11bit) +temperature (11 bit), bit 12 of 0x02 register = 1 <sup>(1)(2)</sup> |     | 1.2       |           | $\mu\text{A}$    |
|                                 |                                | Startup (average on Start-up time)  |     | 300       |           | $\mu\text{A}$    |
| $I_{HEAT}$                      | Heater Current <sup>(3)</sup>  | Peak current  |     | 7.6       |           | mA               |
|                                 |                                | Average @ 1 measurement/second, RH (11bit) +temperature (11 bit), bit 12 of 0x02 register = 1 <sup>(1)(2)</sup> |     | 57        |           | $\mu\text{A}$    |
| <b>RELATIVE HUMIDITY SENSOR</b> |                                |   |     |           |           |                  |
| $RH_{ACC}$                      | Accuracy                       |   |     | $\pm 4$   |           | %RH              |
| $RH_{REP}$                      | Repeatability <sup>(3)</sup>   | 0%RH  |     | $\pm 0.1$ |           | %RH              |
| $RH_{HYS}$                      | Hysteresis <sup>(4)</sup>      |   |     | $\pm 1$   |           | %RH              |
| $RH_{RT}$                       | Response Time <sup>(5)</sup>   | $t_{63\%}$ <sup>(6)</sup>   |     | 15        |           | s                |
| $RH_{CT}$                       | Conversion Time <sup>(3)</sup> | 8 bit resolution  |     | 2.50      |           | ms               |
|                                 |                                | 11 bit resolution   |     | 3.85      |           | ms               |
|                                 |                                | 14 bit resolution   |     | 6.50      |           | ms               |
| $RH_{HOR}$                      | Operating Range <sup>(7)</sup> | Non-condensing  | 0   |           | 100       | %RH              |
| $RH_{LTD}$                      | Long Term Drift                |   |     | $\pm 0.5$ |           | %RH/yr           |
| <b>TEMPERATURE SENSOR</b>       |                                |   |     |           |           |                  |
| $TEMP_{ACC}$                    | Accuracy <sup>(3)</sup>        | $5^\circ\text{C} < T_A < 60^\circ\text{C}$  |     | $\pm 0.2$ | $\pm 0.4$ | $^\circ\text{C}$ |
| $TEMP_{REP}$                    | Repeatability <sup>(3)</sup>   |   |     | $\pm 0.1$ |           | $^\circ\text{C}$ |
| $TEMP_{CT}$                     | Conversion Time <sup>(3)</sup> | 11 bit accuracy   |     | 3.65      |           | ms               |
|                                 |                                | 14 bit accuracy   |     | 6.35      |           | ms               |
| $TEMP_{OR}$                     | Operating Range                |   | -40 |           | 125       | $^\circ\text{C}$ |

(1) I<sup>2</sup>C read/write communication and pull-up resistors current through SCL, SDA and DRDYn not included.

(2) Average current consumption while conversion is in progress.

(3) This parameter is specified by design and/or characterization and it is not tested in production.

(4) The hysteresis value is the difference of measured values of a given sensor at a certain measuring point accruing from a dry environment to a humid environment after a dwell time.

(5) Actual response times will vary dependent on system thermal mass and air-flow.

(6) Time for the RH output to change by 63% of the total RH change after a step change in environmental humidity.

(7) Recommended humidity operating range is 10% to 80% RH. Prolonged operation outside these ranges may result in a measurement shift. The measurement shift will decrease after operating the sensor in the recommended operating range.

## 7.6 I<sup>2</sup>C Interface Electrical Characteristics

 At  $T_A=30^{\circ}\text{C}$ ,  $V_{DD}=3\text{V}$  (unless otherwise noted)

| PARAMETER                                     | TEST CONDITION                        | MIN                 | TYP | MAX                 | UNIT |
|---|---------------------------------------|---------------------|-----|---------------------|------|
| <b>I<sup>2</sup>C INTERFACE VOLTAGE LEVEL</b> |                                       |                     |     |                     |      |
| $V_{IH}$                                      | Input High Voltage                    | $0.7 \times V_{DD}$ |     |                     | V    |
| $V_{IL}$                                      | Input Low Voltage                     |                     |     | $0.3 \times V_{DD}$ | V    |
| $V_{OL}$                                      | Output Low Voltage                    | Sink current 3mA    |     | 0.4                 | V    |
| HYS   | Hysteresis <sup>(1)</sup>             | $0.1 \times V_{DD}$ |     |                     | V    |
| $C_{IN}$                                      | Input Capacitance on all digital pins |                     | 0.5 |                     | pF   |

(1) This parameter is specified by design and/or characterization and it is not tested in production.

## 7.7 I<sup>2</sup>C Interface Timing Requirements

| PARAMETER                                     | TEST CONDITION   | MIN  | TYP | MAX | UNIT          |
|---|--|--|-----|-----|---------------|
| <b>I<sup>2</sup>C INTERFACE VOLTAGE LEVEL</b> |  |  |     |     |               |
| $f_{SCL}$                                     | Clock Frequency  | 10   |     | 400 | kHz           |
| $t_{LOW}$                                     | Clock Low Time   | 1.3  |     |     | $\mu\text{s}$ |
| $t_{HIGH}$                                    | Clock High Time  | 0.6  |     |     | $\mu\text{s}$ |
| $t_{SP}$                                      | Pulse width of spikes that must be suppressed by the input filter <sup>(1)</sup> |  |     | 50  | ns            |
| $t_{START}$                                   | Device Start-up time   | From $V_{DD} \geq 2.7\text{V}$ to ready for a conversion <sup>(1)(2)</sup> | 10  | 15  | ms            |

(1) This parameter is specified by design and/or characterization and it is not tested in production.

(2) Within this interval it is not possible to communicate to the device.

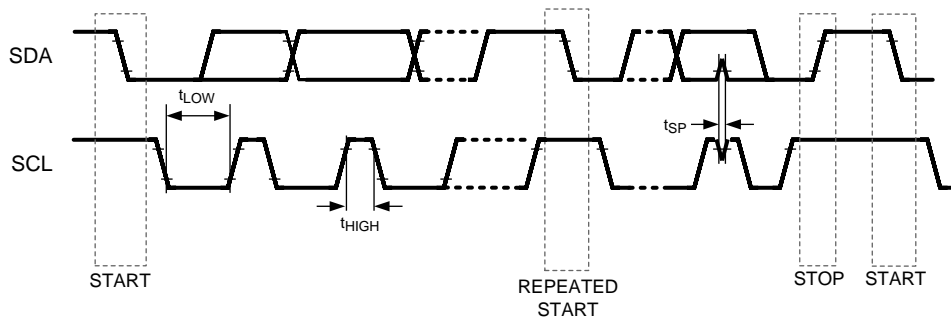
**Figure 1. I<sup>2</sup>C Timing**

## 7.8 Typical Characteristics

Unless otherwise noted,  $T_A = 30^\circ\text{C}$ ,  $V_{DD} = 3\text{V}$ .

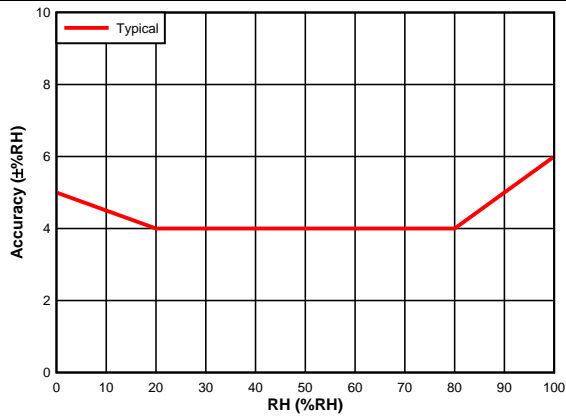

Figure 2. RH Accuracy vs. RH

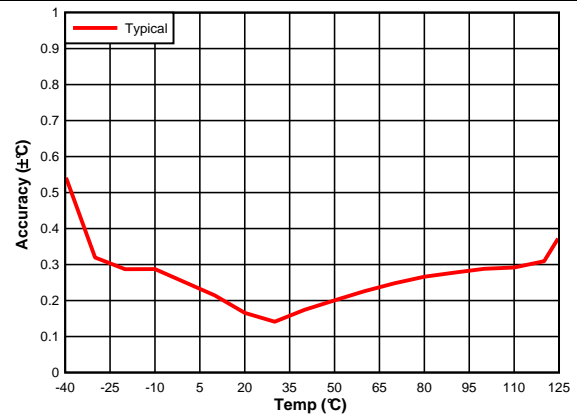

Figure 3. Temperature Accuracy vs. Temperature

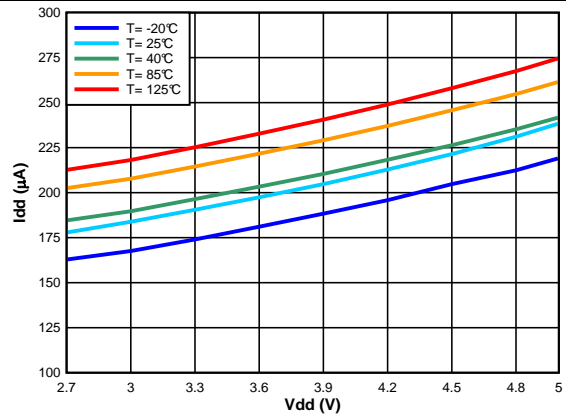

Figure 4. Supply Current vs. Supply Voltage, RH Measurement

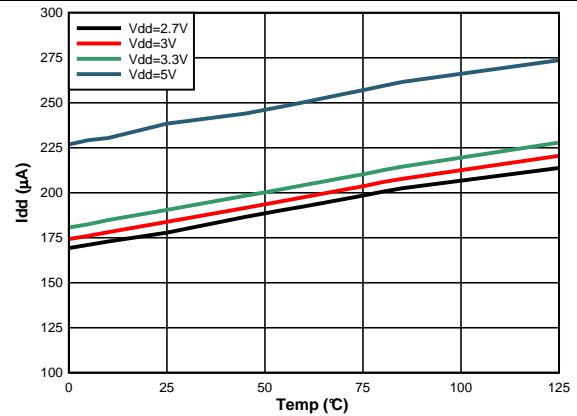

Figure 5. Supply Current vs. Temperature, RH Measurement

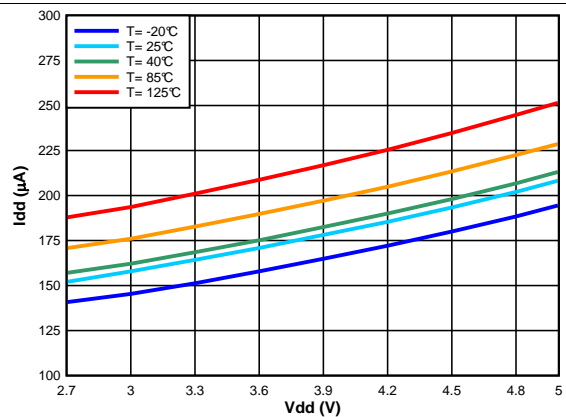

Figure 6. Supply Current vs. Supply Voltage, Temp Measurement

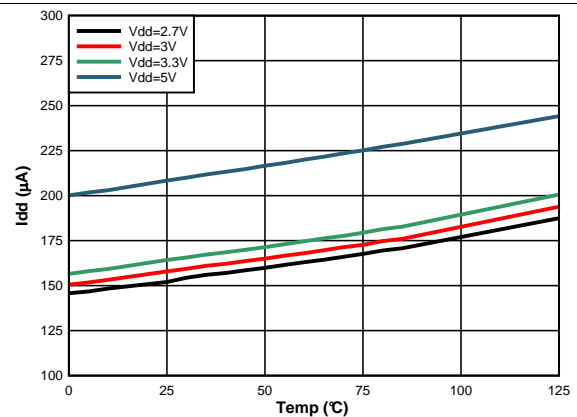
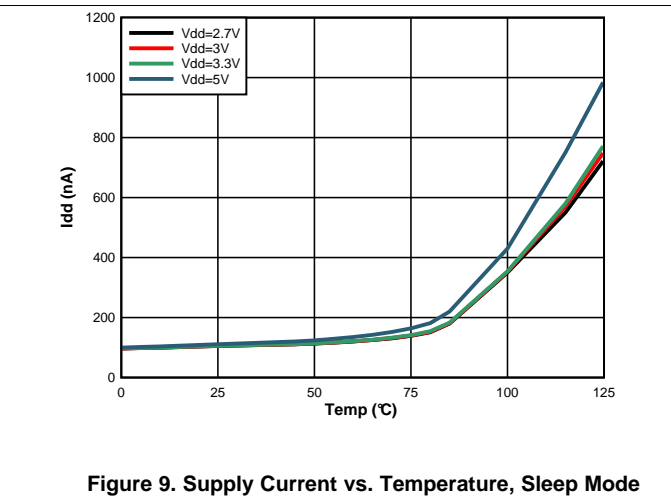
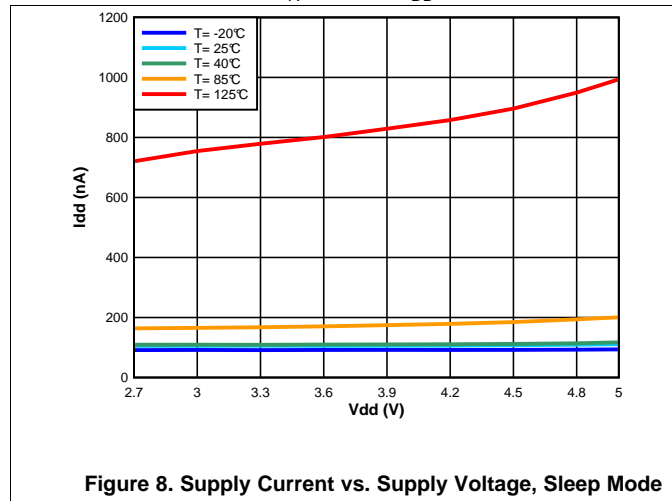

Figure 7. Supply Current vs. Temperature, Temp Measurement

**Typical Characteristics (continued)**

 Unless otherwise noted,  $T_A = 30^\circ\text{C}$ ,  $V_{DD} = 3\text{V}$ .



## 8 Detailed Description

### 8.1 Overview

The HDC1008 is a digital humidity sensor with integrated temperature sensor that provides excellent measurement accuracy at very low power and long term. The sensing element of the HDC1008 is placed on the bottom part of the device, which makes the HDC1008 more robust against dirt, dust, and other environmental contaminants. Measurement results can be read out through the I<sup>2</sup>C compatible interface. Resolution is based on the measurement time and can be 8, 11, or 14 bits for humidity; 11 or 14 bits for temperature.

### 8.2 Functional Block Diagram

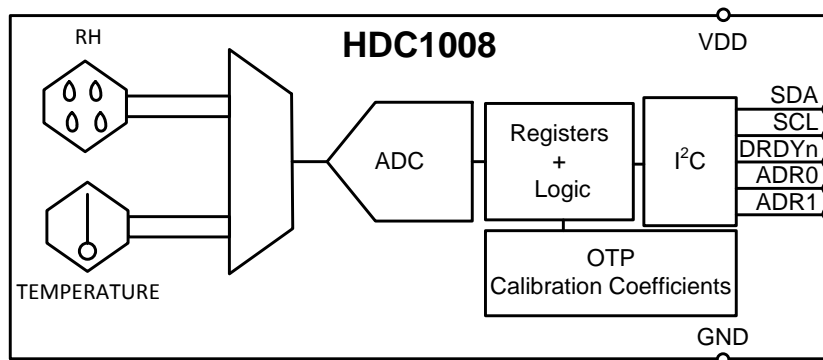

### 8.3 Feature Description

#### 8.3.1 Power Consumption

One of the key features of the HDC1008 is its low power consumption, which makes the device suitable in battery or power harvesting applications. In these applications the HDC1008 spends most of the time in sleep mode; with a typical 110nA of current consumption in sleep mode, the averaged current consumption is minimal. Moreover its low consumption in measurement mode minimizes any self-heating.

#### 8.3.2 Voltage Supply Monitoring

The HDC1008 monitors the supply voltage level and indicates when the voltage supply of the HDC1008 is less than 2.8V. This information is useful in battery-powered systems in order to inform the user to replace the battery. This is reported in the TRES field (register address 0x00:bit[11]), which is updated after POR and after each measurement request.

#### 8.3.3 Heater

The heater is an integrated resistive element that can be used to test the sensor or to drive condensation off the sensor. The heater can be activated using HEAT, bit 13 in Configuration Register. The heater helps in reducing the accumulated offset after long exposure at high humidity conditions.

Once enabled the heater is turned on only in the measurement mode. To have a reasonable increase of the temperature it is suggested to increase the measurement data rate.

### 8.4 Device Functional Modes

The HDC1008 has two modes of operation: sleep mode and measurement mode. After power up, the HDC1008 is in sleep mode. In this mode, the HDC1008 waits for I<sup>2</sup>C input including commands to configure the conversion times, read the status of the battery, trigger a measurement, and read measurements. Once it receives a command to trigger a measurement, the HDC1008 moves from sleep mode to measurement mode. In measurement mode, the HDC1008 acquires the configured measurements and sets the DRDYn line low when the measurement is complete. After completing the measurement and setting DRDYn low, the HDC1008 returns to sleep mode.

## 8.5 Programming

### 8.5.1 I<sup>2</sup>C Serial Bus Address Configuration

To communicate with the HDC1008, the master must first address slave devices via a slave address byte. The slave address byte consists of seven address bits and a direction bit that indicates the intent to execute a read or write operation. The HDC1008 features two address pins to allow up to 4 devices to be addressed on a single bus. [Table 1](#) describes the pin logic levels used to properly connect up to 4 devices. The state of the ADR0 and ADR1 pins is sampled on every bus communication and should be set before any activity on the interface occurs. The address pin is read at the start of each communication event.

**Table 1. HDC1008 ADDRESS**

| ADR1 | ADR0 | ADDRESS (7-bit address) |
|------|------|-------------------------|
| 0    | 0    | 1000000                 |
| 0    | 1    | 1000001                 |
| 1    | 0    | 1000010                 |
| 1    | 1    | 1000011                 |

### 8.5.2 I<sup>2</sup>C Interface

The HDC1008 operates only as a slave device on the I<sup>2</sup>C bus interface. It is not allowed to have on the I<sup>2</sup>C bus multiple devices with the same address. Connection to the bus is made via the open-drain I/O lines, SDA, and SCL. The SDA and SCL pins feature integrated spike-suppression filters and Schmitt triggers to minimize the effects of input spikes and bus noise. After power-up, the sensor needs at most 15 ms, to be ready to start RH and temperature measurement. During this power-up time the HDC1008 is only able to provide the content of the serial number registers (0xFB to 0xFF) if requested. After the power-up the sensor is in the sleep mode until a communication or measurement is performed. All data bytes are transmitted MSB first.

#### 8.5.2.1 Serial Bus Address

To communicate with the HDC1008, the master must first address slave devices via a slave address byte. The slave address byte consists of seven address bits, and a direction bit that indicates the intent to execute a read or write operation.

#### 8.5.2.2 Read and Write Operations

Access a particular register on the HDC1008 by writing the appropriate value to the Pointer Register. The pointer value is the first byte transferred after the slave address byte with the R/W bit low. Every write operation to the HDC1008 requires a value for the pointer register (refer to [Figure 10](#)).

When reading from the HDC1008, the last value stored in the pointer by a write operation is used to determine which register is read by a read operation. To change the pointer register for a read operation, a new value must be written to the pointer. This transaction is accomplished by issuing the slave address byte with the R/W bit low, followed by the pointer byte. No additional data is required (refer to [Figure 11](#)).

The master can then generate a START condition and send the slave address byte with the R/W bit high to initiate the read command. Note that register bytes are sent MSB first, followed by the LSB. A write operation in a read-only register such as (DEVICE ID, MANUFACTURER ID, SERIAL ID) returns a NACK after each data byte; read/write operation to unused address returns a NACK after the pointer; a read/write operation with incorrect I<sup>2</sup>C address returns a NACK after the I<sup>2</sup>C address.

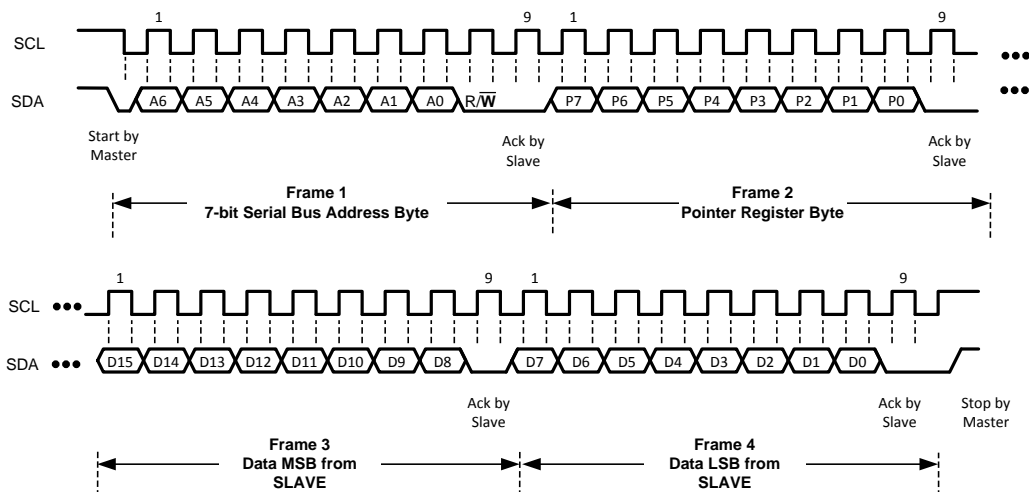

Figure 10. Writing Frame (Configuration Register)

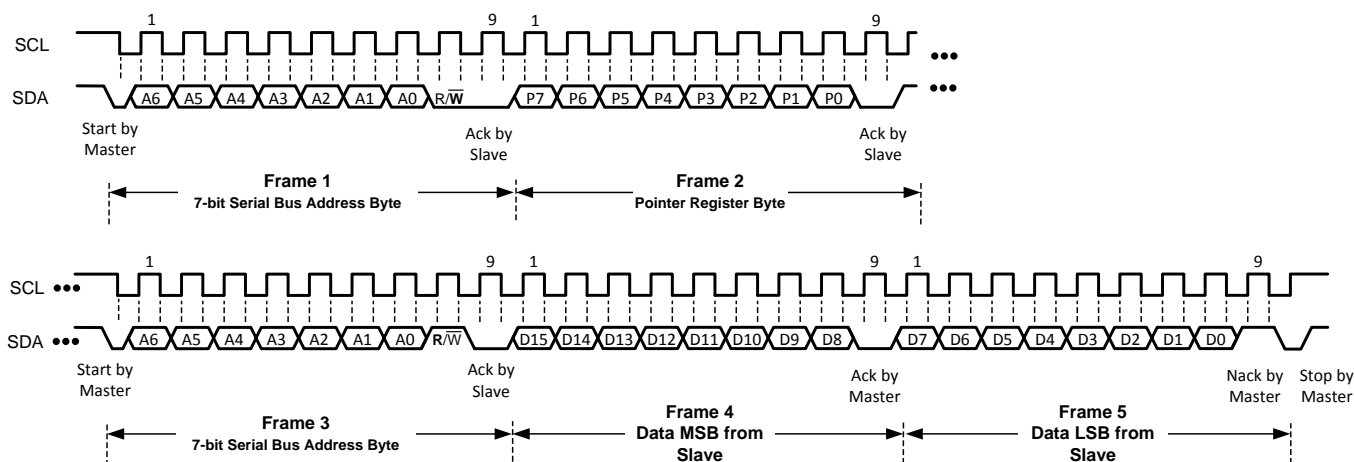

Figure 11. Reading Frame (Configuration Register)

### 8.5.2.3 Device Measurement Configuration

By default the HDC1008 will first perform a temperature measurement followed by a humidity measurement. On power-up, the HDC1008 enters a low power sleep mode and is not actively measuring. Use the following steps to perform a measurement of both temperature and humidity and then retrieve the results:

1. Configure the acquisition parameters in register address 0x02:
  - (a) Set the acquisition mode to measure both temperature and humidity by setting Bit[12] to 1.
  - (b) Set the desired temperature measurement resolution:
    - Set Bit[10] to 0 for 14 bit resolution.
    - Set Bit[10] to 1 for 11 bit resolution.
  - (c) Set the desired humidity measurement resolution:
    - Set Bit[9:8] to 00 for 14 bit resolution.
    - Set Bit[9:8] to 01 for 11 bit resolution.
    - Set Bit[9:8] to 10 for 8 bit resolution.
2. Trigger the measurements by executing a pointer write transaction with the address pointer set to 0x00. Refer to [Figure 12](#).
3. Wait for the measurements to complete, based on the conversion time (refer to [Electrical Characteristics](#) for the conversion time). Alternatively, wait for the assertion of DRDYn.

#### 4. Read the output data:

Read the temperature data from register address 0x00, followed by the humidity data from register address 0x01 in a single transaction as shown in [Figure 14](#). A read operation will return a NACK if the contents of the registers have not been updated as shown in [Figure 13](#).

To perform another acquisition with the same measurement configuration simply repeat steps 2 through 4.

If only a humidity or temperature measurement is desired, the following steps will perform a measurement and retrieve the result:

1. Configure the acquisition parameters in register address 0x02:
  - (a) Set the acquisition mode to independently measure temperature or humidity by setting Bit[12] to 0.
  - (b) For a temperature measurement, set the desired temperature measurement resolution:
    - Set Bit[10] to 0 for 14 bit resolution.
    - Set Bit[10] to 1 for 11 bit resolution.
  - (c) For a humidity measurement, set the desired humidity measurement resolution:
    - Set Bit[9:8] to 00 for 14 bit resolution.
    - Set Bit[9:8] to 01 for 11 bit resolution.
    - Set Bit[9:8] to 10 for 8 bit resolution.
2. Trigger the measurement by executing a pointer write transaction. Refer to [Figure 12](#).
  - Set the address pointer to 0x00 for a temperature measurement.
  - Set the address pointer to 0x01 for a humidity measurement.
3. Wait for the measurement to complete, based on the conversion time (refer to [Electrical Characteristics](#) for the conversion time). Alternatively, wait for the assertion of DRDYn.
4. Read the output data:

Retrieve the completed measurement result from register address 0x00 or 0x01, as appropriate, as shown in [Figure 10](#). A read operation will return a NACK if the measurement result is not yet available, as shown in [Figure 13](#).

To perform another acquisition with the same measurement configuration repeat steps 2 through 4.

It is possible to read the output registers (addresses 0x00 and 0x01) during an Temperature or Relative Humidity measurement without affecting any ongoing measurement. Note that a write to address 0x00 or 0x01 while a measurement is ongoing will abort the ongoing measurement. If the newest acquired measurement is not read, DRDYn stays low until the next measurement is triggered.

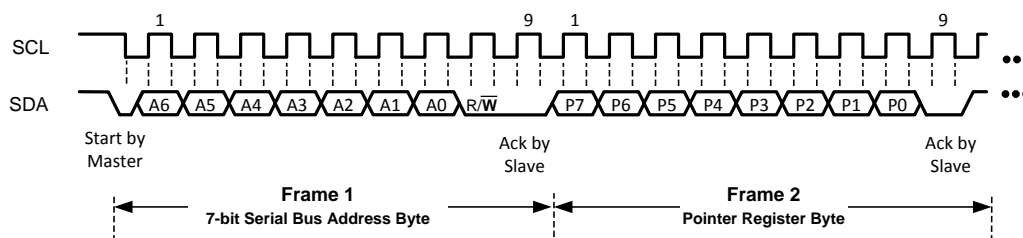

**Figure 12. Trigger Humidity/Temperature Measurement**

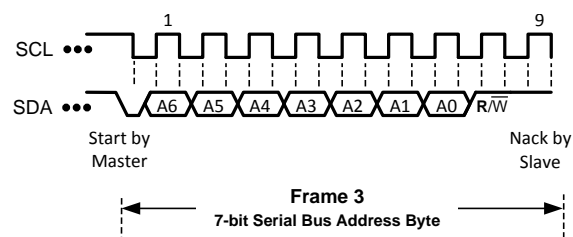

**Figure 13. Read Humidity/Temperature Measurement (Data Not Ready)**

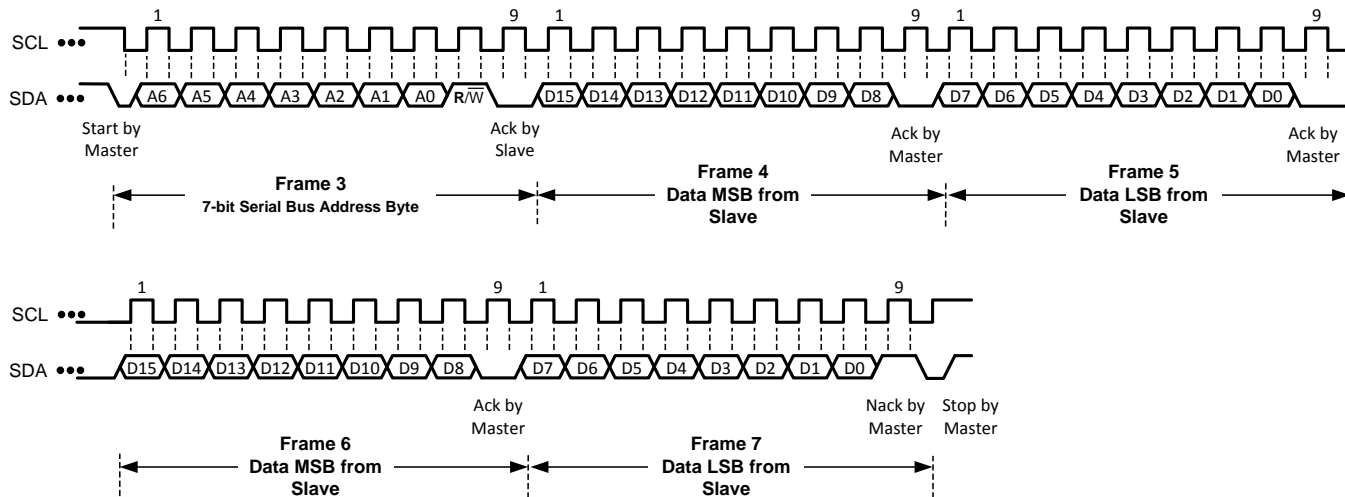

Figure 14. Read Humidity and Temperature Measurement (Data Ready)

## 8.6 Register Map

The HDC1008 contains data registers that hold configuration information, temperature and humidity measurement results, and status information.

**Table 2. Register Map**

| POINTER | NAME          | RESET VALUE      | DESCRIPTION                                |
|---------|---------------|------------------|--|
| 0x00    | Temperature   | 0x0000           | Temperature measurement output             |
| 0x01    | Humidity      | 0x0000           | Relative Humidity measurement output       |
| 0x02    | Configuration | 0x1000           | HDC1008 configuration and status           |
| 0xFB    | Serial ID     | device dependent | First 2 bytes of the serial ID of the part |
| 0xFC    | Serial ID     | device dependent | Mid 2 bytes of the serial ID of the part   |
| 0xFD    | Serial ID     | device dependent | Last byte bit of the serial ID of the part |

Registers from 0x03 to 0xFA are reserved and should not be written.

The HDC1008 has an 8-bit pointer used to address a given data register. The pointer identifies which of the data registers should respond to a read or write command on the two-wire bus. This register is set with every write command. A write command must be issued to set the proper value in the pointer before executing a read command. The power-on reset (POR) value of the pointer is 0x00, which selects a temperature measurement.

### 8.6.1 Temperature Register

The temperature register is a 16-bit result register in binary format (the 2 LSBs D1 and D0 are always 0). The result of the acquisition is always a 14 bit value, while the accuracy is related to the selected conversion time (refer to [Electrical Characteristics](#)). The temperature can be calculated from the output data with:

$$\text{Temperature}(\text{°C}) = \left( \frac{\text{TEMPERATURE}[15:00]}{2^{16}} \right) * 165\text{°C} - 40\text{°C} \quad (1)$$

**Table 3. Temperature Register Description (0x00)**

| NAME        | REGISTERS |             | DESCRIPTION                         |
|-------------|-----------|-------------|-------------------------------------|
| TEMPERATURE | [15:02]   | Temperature | Temperature measurement (read only) |
|             | [01:00]   | Reserved    | Reserved, always 0 (read only)      |

### 8.6.2 Humidity Register

The humidity register is a 16-bit result register in binary format (the 2 LSBs D1 and D0 are always 0). The result of the acquisition is always a 14 bit value, while the accuracy is related to the selected conversion time (refer to [Electrical Characteristics](#)). The humidity can be calculated from the output data with:

$$\text{Relative Humidity}(\% \text{ RH}) = \left( \frac{\text{HUMIDITY}[15:00]}{2^{16}} \right) * 100\% \text{RH} \quad (2)$$

**Table 4. Humidity Register Description (0x01)**

| NAME     | REGISTERS |                   | DESCRIPTION                               |
|----------|-----------|-------------------|---|
| HUMIDITY | [15:02]   | Relative Humidity | Relative Humidity measurement (read only) |
|          | [01:00]   | Reserved          | Reserved, always 0 (read only)            |

### 8.6.3 Configuration Register

This register configures device functionality and returns status.

**Table 5. Configuration Register Description (0x02)**

| NAME     | REGISTERS | DESCRIPTION                        |    |   |
|----------|-----------|------------------------------------|----|---|
| RST      | [15]      | Software reset bit                 | 0  | Normal Operation, this bit self clears                                |
|          |           |                                    | 1  | Software Reset  |
| Reserved | [14]      | Reserved                           | 0  | Reserved, must be 0   |
| HEAT     | [13]      | Heater                             | 0  | Heater Disabled   |
|          |           |                                    | 1  | Heater Enabled  |
| MODE     | [12]      | Mode of acquisition                | 0  | Temperature or Humidity is acquired.                                  |
|          |           |                                    | 1  | Temperature and Humidity are acquired in sequence, Temperature first. |
| BTST     | [11]      | Battery Status                     | 0  | Battery voltage > 2.8V (read only)                                    |
|          |           |                                    | 1  | Battery voltage < 2.8V (read only)                                    |
| TRES     | [10]      | Temperature Measurement Resolution | 0  | 14 bit  |
|          |           |                                    | 1  | 11 bit  |
| HRES     | [9:8]     | Humidity Measurement Resolution    | 00 | 14 bit  |
|          |           |                                    | 01 | 11 bit  |
|          |           |                                    | 10 | 8 bit   |
| Reserved | [7:0]     | Reserved                           | 0  | Reserved, must be 0   |

### 8.6.4 Serial Number Registers

These registers contain a 40bit unique serial number for each individual HDC1008.

**Table 6. Serial Number Register Description (0xFB)**

| NAME             | REGISTERS | DESCRIPTION    |   |
|------------------|-----------|----------------|---|
| SERIAL ID[39:24] | [15:0]    | Serial Id bits | Device Serial Number bits from 39 to 24 (read only) |

**Table 7. Serial Number Register Description (0xFC)**

| NAME            | REGISTERS | DESCRIPTION    |  |
|-----------------|-----------|----------------|--|
| SERIAL ID[23:8] | [15:0]    | Serial Id bits | Device Serial Number bits from 23 to 8 (read only) |

**Table 8. Serial Number Register Description (0xFD)**

| NAME           | REGISTERS | DESCRIPTION    |   |
|----------------|-----------|----------------|---|
| SERIAL ID[7:0] | [15:7]    | Serial ID bits | Device Serial Number bits from 7 to 0 (read only) |
|                | [6:0]     | Reserved       | Reserved, always 0 (read only)                    |

## 9 Application and Implementation

### NOTE

Information in the following applications sections is not part of the TI component specification, and TI does not warrant its accuracy or completeness. TI's customers are responsible for determining suitability of components for their purposes. Customers should validate and test their design implementation to confirm system functionality.

### 9.1 Application Information

A HVAC or Thermostat are based on environmental sensors and a micro-controller which acquires data from humidity sensors and temperature sensors and controls the heating/cooling system. The collected data are then showed on a display that can be easily controlled by the micro controller. Based on data from the humidity and temperature sensor, the heating/cooling system then maintains the environment at customer-defined preferred conditions.

### 9.2 Typical Application

In a battery-powered HVAC or thermostat, one of the key parameters in the selection of components is the power consumption. The HDC1008, with its 1.2 $\mu$ A of current consumption (average consumption over 1s for RH and Temperature measurements) in conjunction with an MSP430 represents an excellent choice for the low power consumption, which extends the battery life. A system block diagram of a battery powered HVAC or Thermostat is shown in [Figure 15](#).

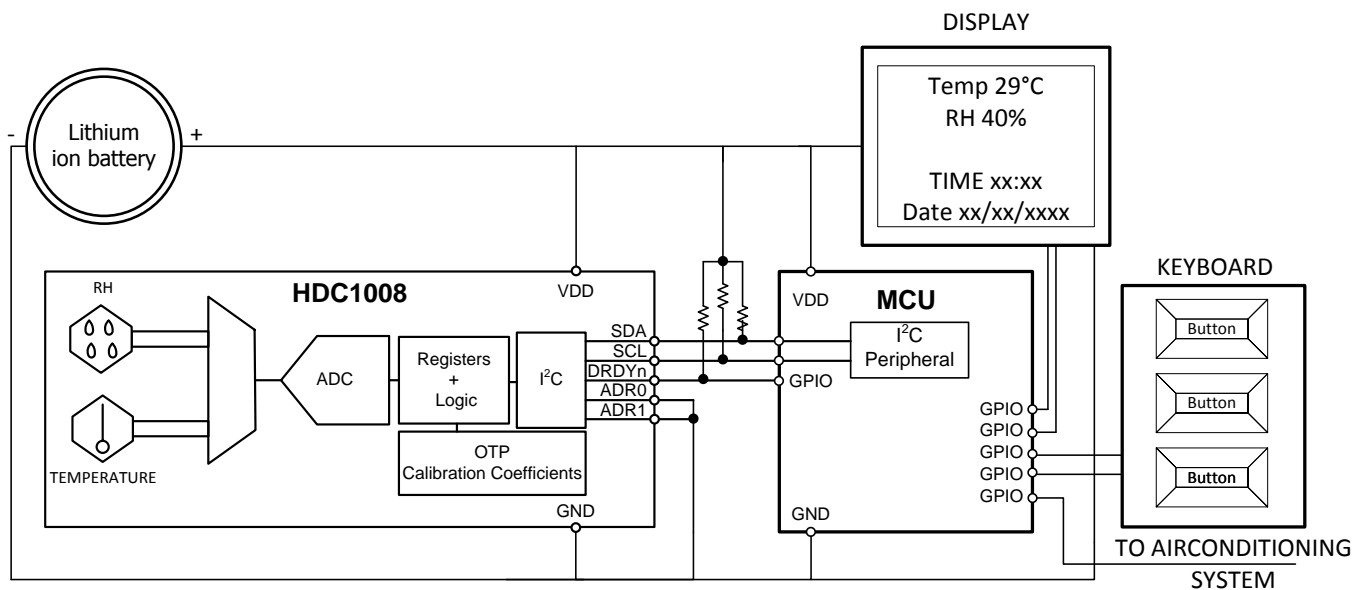

**Figure 15. Typical Application Schematic HVAC**

#### 9.2.1 Design Requirements

In order to correctly sense the ambient temperature and humidity, the HDC1008 should be positioned away from heat sources on the PCB. Generally, it should not be close to the LCD and battery. Moreover, to minimize any self-heating of the HDC1008 it is recommended to acquire at a maximum sample rate of 1sps (RH + Temp). In home systems, humidity and the temperature monitoring rates of less than 1sps (even 0.5sps or 0.2sps) can be still effective.



## Typical Application (continued)

### 9.2.2 Detailed Design Procedure

When a circuit board layout is created from the schematic shown in [Figure 15](#), a small circuit board is possible. The accuracy of a RH and temperature measurement depends on the sensor accuracy and the setup of the sensing system. The HDC1008 samples relative humidity and temperature in its immediate environment, it is therefore important that the local conditions at the sensor match the monitored environment. Use one or more openings in the physical cover of the HVAC to obtain a good airflow even in static conditions. Refer to the layout below ([Figure 19](#)) for a PCB layout which minimizes the thermal mass of the PCB in the region of the HDC1008, which can improve measurement response time and accuracy.

### 9.2.3 Application Curve

The data showed below have been acquired with the HDC1000EVM populated with HDC1008 . The environment conditions have been evaluated in a humidity chamber.

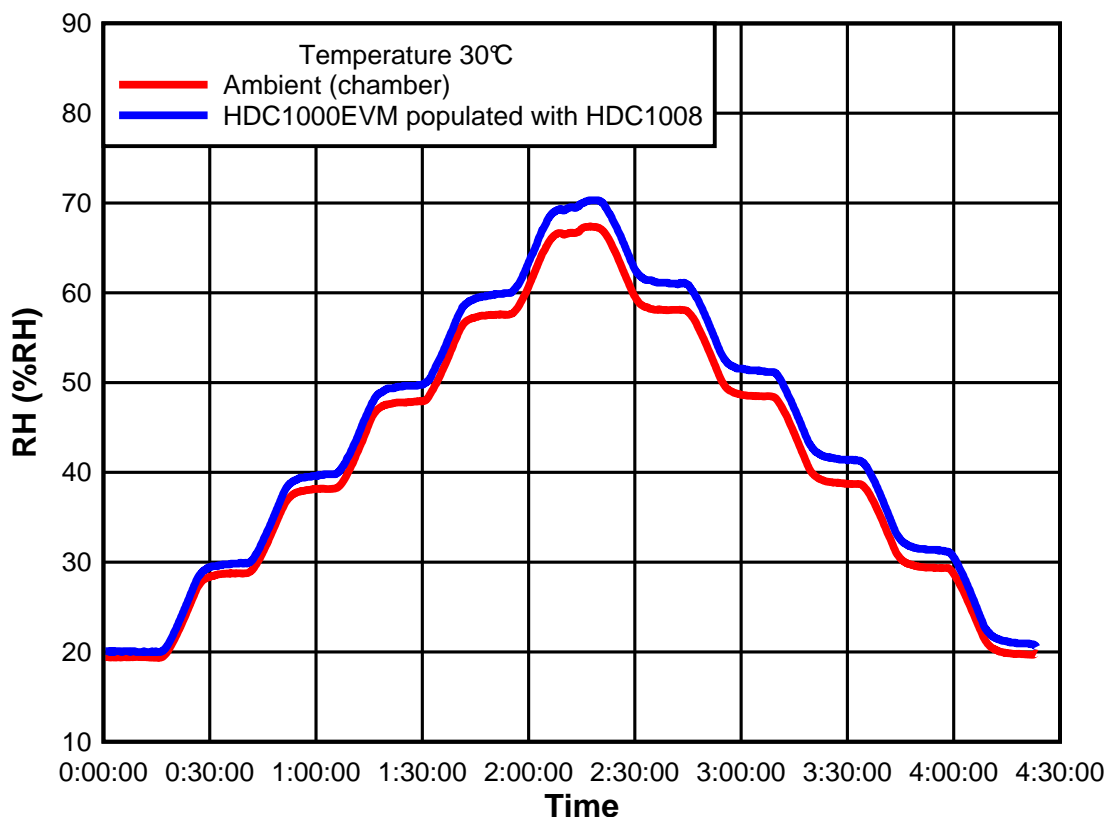

Figure 16. RH vs. Time

## 9.3 Do's and Don'ts

### 9.3.1 Soldering

For soldering HDC1008, standard reflow soldering ovens may be used. The sensor is qualified to withstand soldering profile according to IPC/JEDEC J-STD-020 with peak temperatures at 260 °C. Refer to the document [SNVA009](#) for more details on the DSBGA package. In the document refer to DSBGA package with bump size 0.5mm pitch and 0.32mm diameter.

When soldering the HDC1008 it is mandatory to use no-clean solder paste and no board wash shall be applied. The HDC1008 should be limited to a single IR reflow and no rework is recommended.

### 9.3.2 Recovery From Soldering

After soldering, the HDC1008 may exhibit an RH offset error but will slowly recover when the humidity sensor is exposed to ambient conditions.

### 9.3.3 Chemical Exposure

The humidity sensor is not a standard IC and therefore should not be exposed to volatile chemicals such as solvents or other organic compounds. If any type of protective coating must be applied to the circuit board, the sensor must be protected during the coating process.

## 10 Power Supply Recommendations

The HDC1008 require a voltage supply within 2.7V and 5.5V. A multilayer ceramic bypass X7R capacitor of 0.1µF between VDD and GND pin is recommended.

## 11 Layout

### 11.1 Layout Guidelines

The Relative Humidity sensor element is located on the bottom side of the package. It is positioned between the two rows of bumps.

It is recommended to not route any traces below the sensor element. Moreover, the external components, such as pull-up resistors and bypass capacitors need to be placed next to the 2 rows of bumps or on the bottom side of the PCB in order to guarantee a good air flow.

#### 11.1.1 Surface Mount

Two types of PCB land patterns are used for surface mount packages:

1. Non-solder mask defined (NSMD)
2. Solder mask defined (SMD)

Pros and cons of NSMD and SMD:

1. The NSMD configuration is preferred due to its tighter control of the copper etch process and a reduction in the stress concentration points on the PCB side compared to SMD configuration.
2. A copper layer thickness of less than 1 oz. is recommended to achieve higher solder joint stand-off. A 1 oz. (35 micron) or greater copper thickness causes a lower effective solder joint stand-off, which may compromise solder joint reliability.
3. For the NSMD pad geometry, the trace width at the connection to the land pad should not exceed 2/3 of the pad diameter.

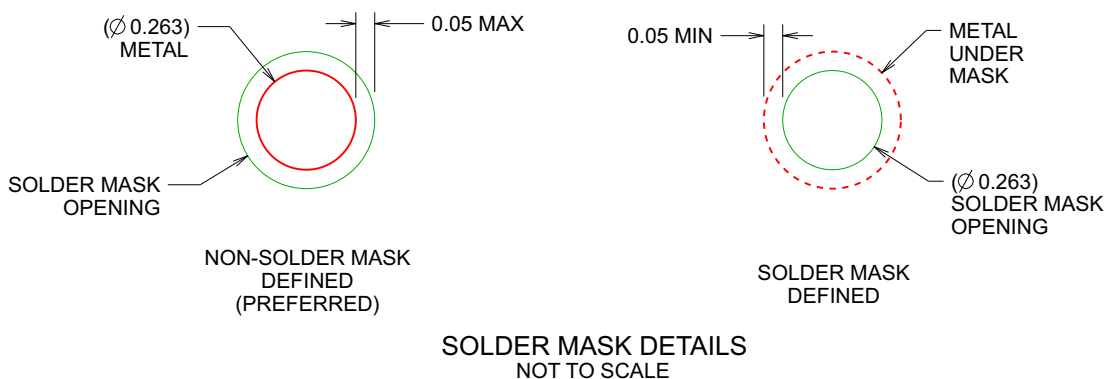
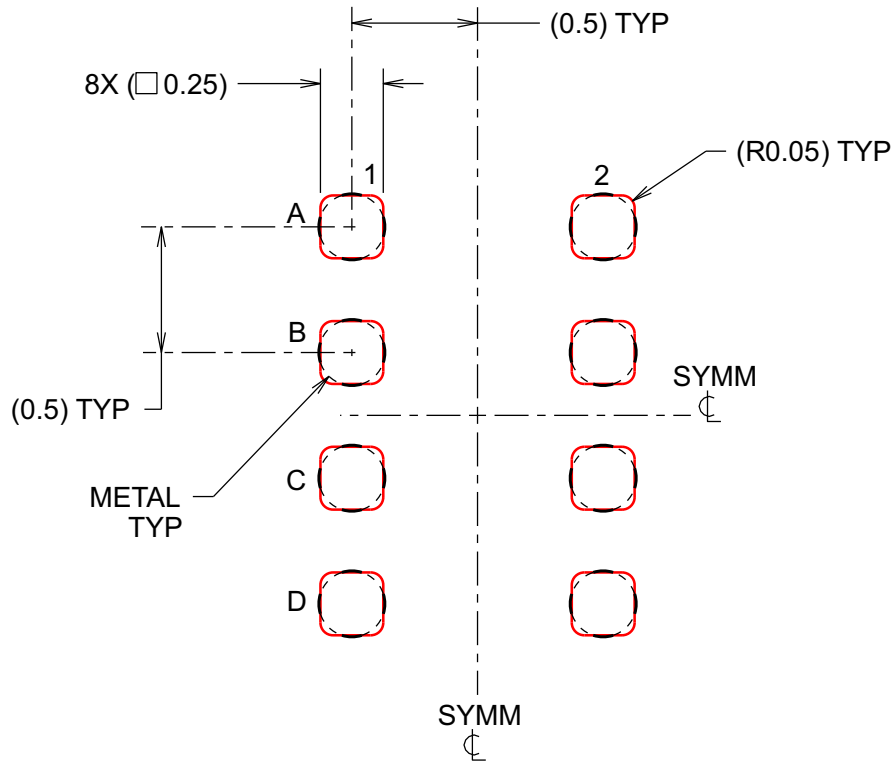

**Figure 17. Solder Mask**

**Layout Guidelines (continued)**

**11.1.2 Stencil Printing Process**

1. Use laser cutting followed by electro-polishing for stencil fabrication.
2. If possible, offset apertures from land pads to maximize separation and minimize possibility of bridging for DSBGA packages.
3. Use Type 3 (25 to 45 micron particle size range) or finer solder paste for printing.



**SOLDER PASTE EXAMPLE**  
 BASED ON 0.1mm THICK STENCIL  
 SCALE:25X

**Figure 18. Solder Paste**

## 11.2 Layout Example

The only component next to the device is the supply bypass capacitor. Since the relative humidity is dependent on the temperature, the HDC1008 should be positioned away from hot points present on the board such as battery, display or micro-controller. Slots around the device can be used to reduce the thermal mass for a quicker response to environmental changes.

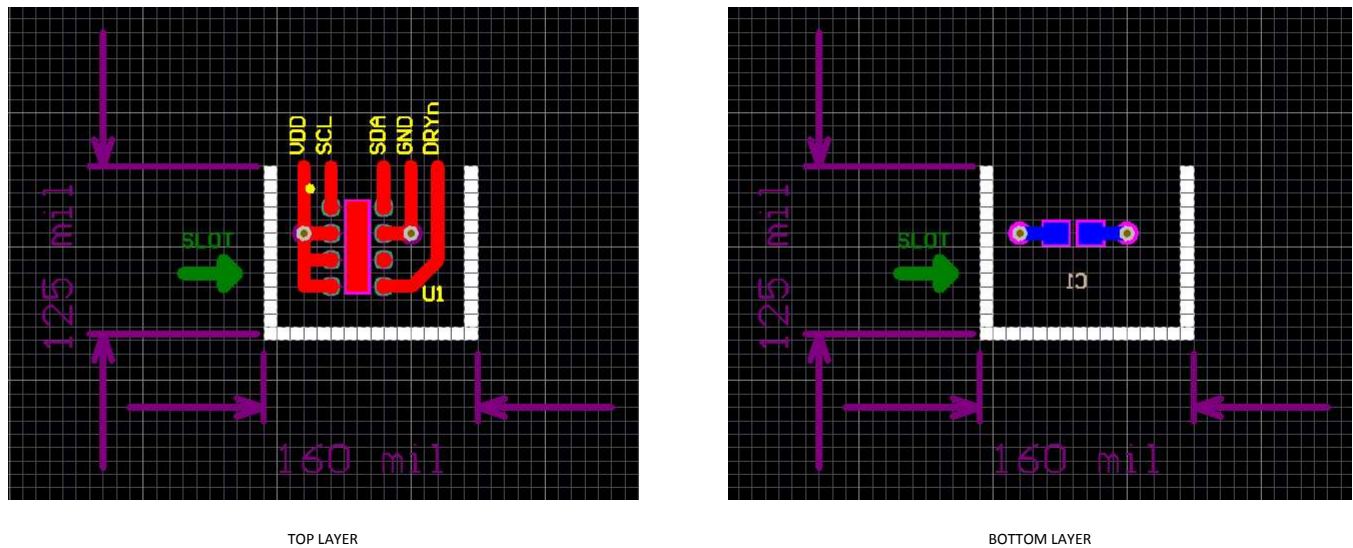

Figure 19. HDC1008 Layout

## 12 器件和文档支持

### 12.1 文档支持

#### 12.1.1 相关文档

《HDC1000 德州仪器 (TI) 湿度传感器》，[SNAA216](#)

《AN-1112 微型表面贴装器件 (SMD) 晶圆级芯片规模封装》，[SNVA009](#)

### 12.2 商标

All trademarks are the property of their respective owners.

### 12.3 静电放电警告



这些装置包含有限的内置 ESD 保护。存储或装卸时，应将导线一起截短或将装置放置于导电泡棉中，以防止 MOS 门极遭受静电损伤。

### 12.4 术语表

[SLYZ022](#) — TI 术语表。

这份术语表列出并解释术语、首字母缩略词和定义。

## 13 机械封装和可订购信息

以下页中包括机械封装和可订购信息。 这些信息是针对指定器件可提供的最新数据。 这些数据会在无通知且不对本文档进行修订的情况下发生改变。 欲获得该数据表的浏览器版本，请查阅左侧的导航栏。

**PACKAGING INFORMATION**

| Orderable part number | Status<br>(1) | Material type<br>(2) | Package   Pins  | Package qty   Carrier | RoHS<br>(3) | Lead finish/<br>Ball material<br>(4) | MSL rating/<br>Peak reflow<br>(5) | Op temp (°C) | Part marking<br>(6) |
|-----------------------|---------------|----------------------|-----------------|-----------------------|-------------|--------------------------------------|-----------------------------------|--------------|---------------------|
| HDC1008YPAR           | NRND          | Production           | DSBGA (YPA)   8 | 3000   LARGE T&R      | Yes         | SNAGCU                               | Level-1-260C-UNLIM                | -40 to 125   | GK                  |
| HDC1008YPAR.A         | NRND          | Production           | DSBGA (YPA)   8 | 3000   LARGE T&R      | Yes         | SNAGCU                               | Level-1-260C-UNLIM                | -40 to 125   | GK                  |

(1) **Status:** For more details on status, see our [product life cycle](#).

(2) **Material type:** When designated, preproduction parts are prototypes/experimental devices, and are not yet approved or released for full production. Testing and final process, including without limitation quality assurance, reliability performance testing, and/or process qualification, may not yet be complete, and this item is subject to further changes or possible discontinuation. If available for ordering, purchases will be subject to an additional waiver at checkout, and are intended for early internal evaluation purposes only. These items are sold without warranties of any kind.

(3) **RoHS values:** Yes, No, RoHS Exempt. See the [TI RoHS Statement](#) for additional information and value definition.

(4) **Lead finish/Ball material:** Parts may have multiple material finish options. Finish options are separated by a vertical ruled line. Lead finish/Ball material values may wrap to two lines if the finish value exceeds the maximum column width.

(5) **MSL rating/Peak reflow:** The moisture sensitivity level ratings and peak solder (reflow) temperatures. In the event that a part has multiple moisture sensitivity ratings, only the lowest level per JEDEC standards is shown. Refer to the shipping label for the actual reflow temperature that will be used to mount the part to the printed circuit board.

(6) **Part marking:** There may be an additional marking, which relates to the logo, the lot trace code information, or the environmental category of the part.

Multiple part markings will be inside parentheses. Only one part marking contained in parentheses and separated by a "~" will appear on a part. If a line is indented then it is a continuation of the previous line and the two combined represent the entire part marking for that device.

**Important Information and Disclaimer:**The information provided on this page represents TI's knowledge and belief as of the date that it is provided. TI bases its knowledge and belief on information provided by third parties, and makes no representation or warranty as to the accuracy of such information. Efforts are underway to better integrate information from third parties. TI has taken and continues to take reasonable steps to provide representative and accurate information but may not have conducted destructive testing or chemical analysis on incoming materials and chemicals. TI and TI suppliers consider certain information to be proprietary, and thus CAS numbers and other limited information may not be available for release.

In no event shall TI's liability arising out of such information exceed the total purchase price of the TI part(s) at issue in this document sold by TI to Customer on an annual basis.

**TAPE AND REEL INFORMATION**

**QUADRANT ASSIGNMENTS FOR PIN 1 ORIENTATION IN TAPE**

\*All dimensions are nominal

| Device      | Package Type | Package Drawing | Pins | SPQ  | Reel Diameter (mm) | Reel Width W1 (mm) | A0 (mm) | B0 (mm) | K0 (mm) | P1 (mm) | W (mm) | Pin1 Quadrant |
|-------------|--------------|-----------------|------|------|--------------------|--------------------|---------|---------|---------|---------|--------|---------------|
| HDC1008YPAR | DSBGA        | YPA             | 8    | 3000 | 178.0              | 8.4                | 1.68    | 2.13    | 0.76    | 4.0     | 8.0    | Q1            |



**TAPE AND REEL BOX DIMENSIONS**

\*All dimensions are nominal

| Device      | Package Type | Package Drawing | Pins | SPQ  | Length (mm) | Width (mm) | Height (mm) |
|-------------|--------------|-----------------|------|------|-------------|------------|-------------|
| HDC1008YPAR | DSBGA        | YPA             | 8    | 3000 | 210.0       | 185.0      | 35.0        |

YPA0008

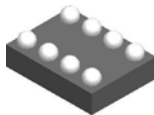

DSBGA - 0.675 mm max height

DIE SIZE BALL GRID ARRAY

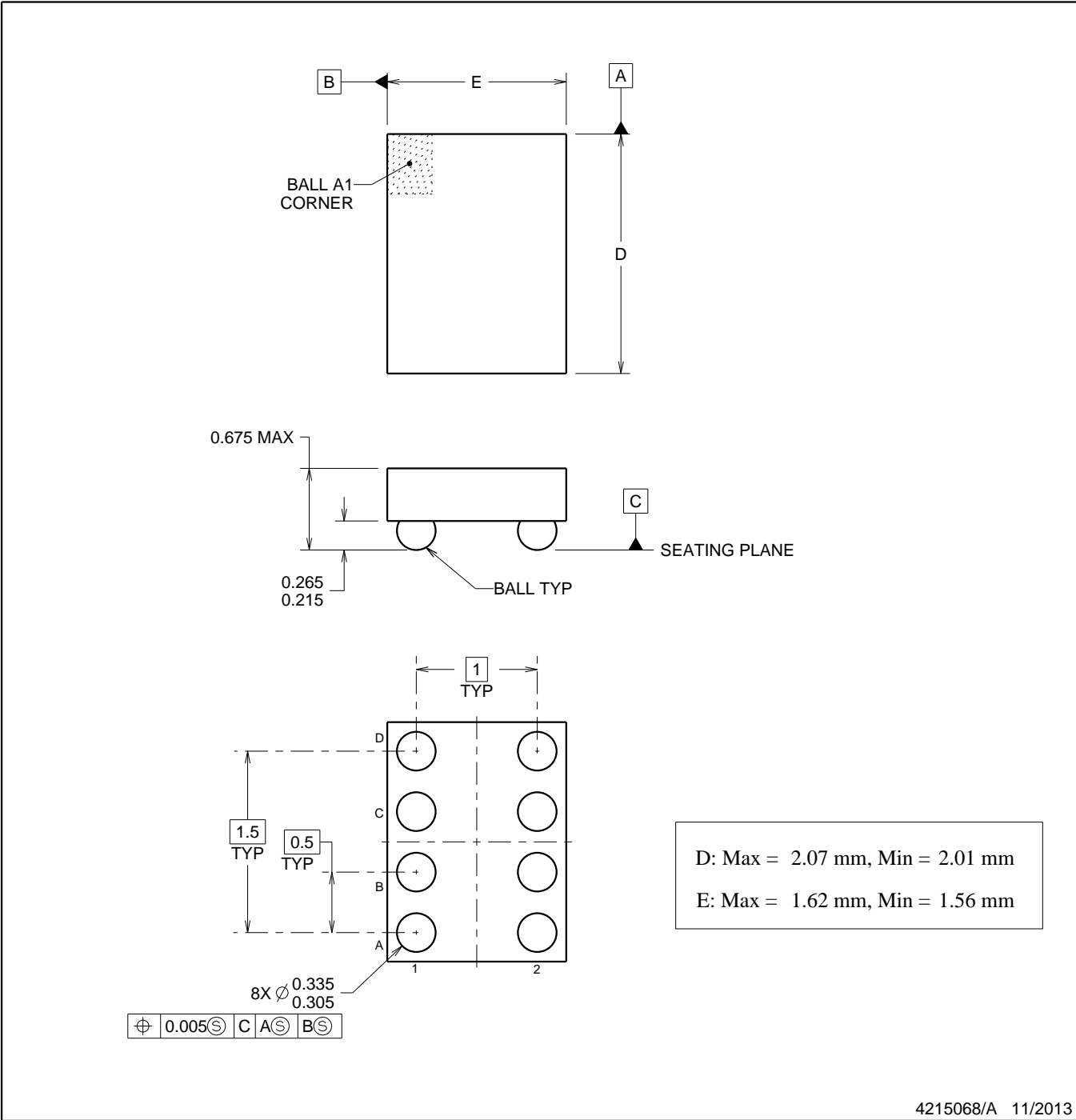

NOTES:

- 1. All linear dimensions are in millimeters. Dimensions in parenthesis are for reference only. Dimensioning and tolerancing per ASME Y14.5M.
- 2. This drawing is subject to change without notice.

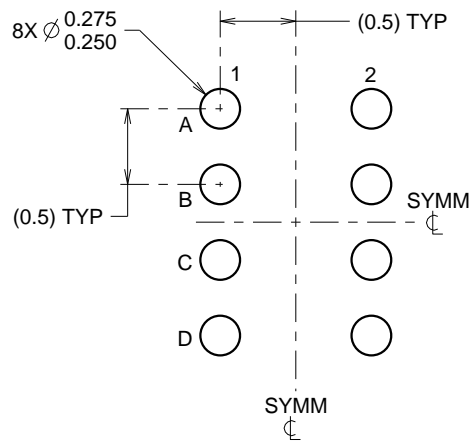

LAND PATTERN EXAMPLE  
SCALE:20X

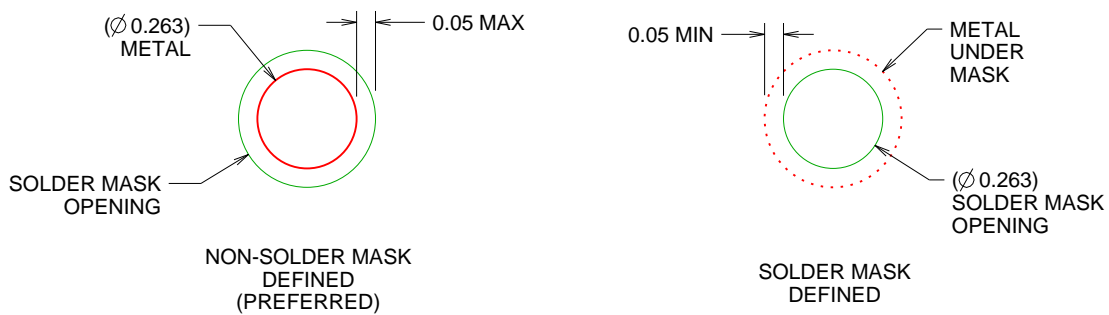

SOLDER MASK DETAILS  
NOT TO SCALE

4215068/A 11/2013

NOTES: (continued)

- 3. Final dimensions may vary due to manufacturing tolerance considerations and also routing constraints. See Texas Instruments Literature No. SBVA017 ([www.ti.com/lit/sbva017](http://www.ti.com/lit/sbva017)).

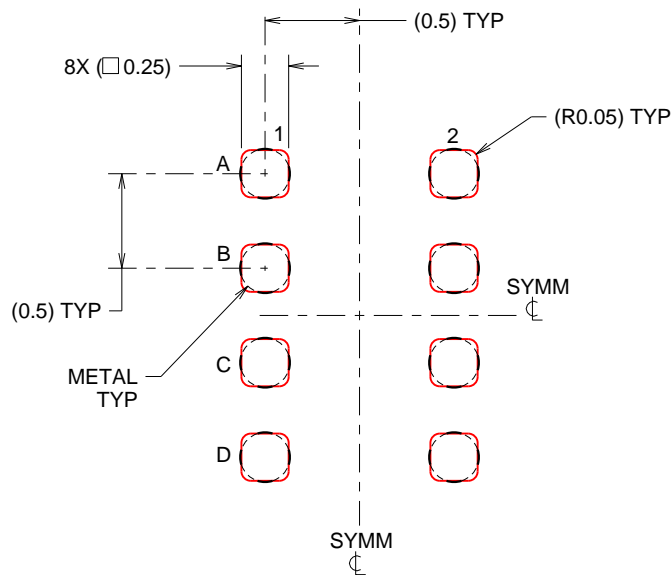

SOLDER PASTE EXAMPLE  
 BASED ON 0.1mm THICK STENCIL  
 SCALE:25X

NOTES: (continued)

- 4. Laser cutting apertures with trapezoidal walls and rounded corners may offer better paste release.

## 重要通知和免责声明

TI“按原样”提供技术和可靠性数据（包括数据表）、设计资源（包括参考设计）、应用或其他设计建议、网络工具、安全信息和其他资源，不保证没有瑕疵且不做任何明示或暗示的担保，包括但不限于对适销性、与某特定用途的适用性或不侵犯任何第三方知识产权的暗示担保。

这些资源可供使用 TI 产品进行设计的熟练开发人员使用。您将自行承担以下全部责任：(1) 针对您的应用选择合适的 TI 产品，(2) 设计、验证并测试您的应用，(3) 确保您的应用满足相应标准以及任何其他安全、安保法规或其他要求。

这些资源如有变更，恕不另行通知。TI 授权您仅可将这些资源用于研发本资源所述的 TI 产品的相关应用。严禁以其他方式对这些资源进行复制或展示。您无权使用任何其他 TI 知识产权或任何第三方知识产权。对于因您对这些资源的使用而对 TI 及其代表造成的任何索赔、损害、成本、损失和债务，您将全额赔偿，TI 对此概不负责。

TI 提供的产品受 [TI 销售条款](#)、[TI 通用质量指南](#) 或 [ti.com](#) 上其他适用条款或 TI 产品随附的其他适用条款的约束。TI 提供这些资源并不会扩展或以其他方式更改 TI 针对 TI 产品发布的适用的担保或担保免责声明。除非德州仪器 (TI) 明确将某产品指定为定制产品或客户特定产品，否则其产品均为按确定价格收入目录的标准通用器件。

TI 反对并拒绝您可能提出的任何其他或不同的条款。

版权所有 © 2025，德州仪器 (TI) 公司

最后更新日期：2025 年 10 月