

DS26LV32AQML 3V Enhanced CMOS Quad Differential Line Receiver

Check for Samples: [DS26LV32AQML](#)

FEATURES

- Comparable to Both TIA/EIA-422 and ITU-T V.11 Standards
- Low Power CMOS Design (30 mW typical)
- Interoperable with Existing 5V RS-422 Networks
- Receiver OPEN Input Failsafe Feature
- Pin Compatible with DS26C32AT

DESCRIPTION

The DS26LV32A is a high speed quad differential CMOS receiver that is comparable to TIA/EIA-422-B and ITU-T V.11 standards, but with a specified common mode voltage range of -0.5V to +5.5V due to the lower operating supply voltage of 3.0V to 3.6V. The TRI-STATE enables, EN and $\overline{\text{EN}}$, allow the device to be active High or active Low. The enables are common to all four receivers. The receiver output (RO) is specified to be High when the inputs are left open. The receiver can detect signals as low as $\pm 200\text{mV}$ over the common mode range of -0.5V to +5.5V. The receiver outputs (RO) are compatible with TTL and LVCMOS levels.

Connection Diagram

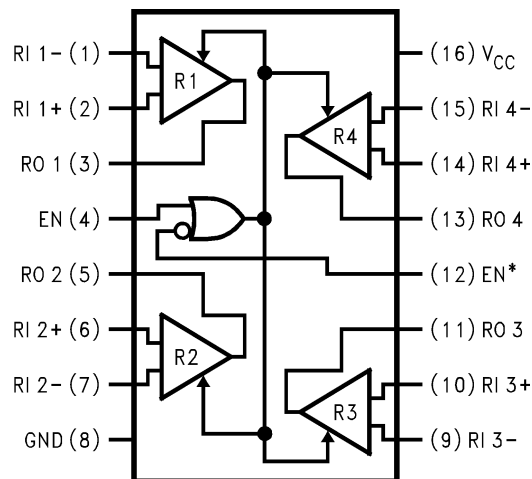

Figure 1. CLGA Package- Top View
See Package Number NAD0016A



Please be aware that an important notice concerning availability, standard warranty, and use in critical applications of Texas Instruments semiconductor products and disclaimers thereto appears at the end of this data sheet.

All trademarks are the property of their respective owners.



These devices have limited built-in ESD protection. The leads should be shorted together or the device placed in conductive foam during storage or handling to prevent electrostatic damage to the MOS gates.

Absolute Maximum Ratings⁽¹⁾

Supply Voltage (V_{CC})	7.0V
Common Mode Range (V_{CM})	$\pm 14V$
Differential Input Voltage (V_{Diff})	$\pm 14V$
Enable Input Voltage (V_I)	-0.5V to $V_{CC}+0.5V$
Storage Temperature Range (T_{Stg})	$-65^{\circ}C \leq T_A \leq +150^{\circ}C$
Lead Temperature (T_L) Soldering, 4 seconds	260°C
Maximum Power Dissipation +25°C ⁽²⁾	1087mW
Thermal Resistance	
θ_{JA}	138°C/W
θ_{JC}	13.5°C/W

- (1) Absolute Maximum Ratings indicate limits beyond which damage to the device may occur. Operating Ratings indicate conditions for which the device is functional, but do not verify specific performance limits. For verified specifications and test conditions, see the Electrical Characteristics. The verified specifications apply only for the test conditions listed. Some performance characteristics may degrade when the device is not operated under the listed test conditions.
- (2) Derate CERPAK 7.3mW/°C above +25°C.

Recommended Operating Conditions

Supply Voltage (v_{CC})	3.0V to 3.6V
Operating Temperature Range (T_A)	$-55^{\circ}C \leq T_A \leq +125^{\circ}C$

Table 1. Quality Conformance Inspection Mil-Std-883, Method 5005 - Group A

Subgroup	Description	Temp °C
1	Static tests at	25
2	Static tests at	125
3	Static tests at	-55
4	Dynamic tests at	25
5	Dynamic tests at	125
6	Dynamic tests at	-55
7	Functional tests at	25
8A	Functional tests at	125
8B	Functional tests at	-55
9	Switching tests at	25
10	Switching tests at	125
11	Switching tests at	-55
12	Settling time at	25
13	Settling time at	125
14	Settling time at	-55

DS26LV32AQL Electrical Characteristics DC Parameters

Parameter		Test Conditions	Notes	Min	Max	Units	Sub-groups
V _{Th}	Minimum Differential Input Voltage	V _{CC} = 3.0/3.6V, V _O = V _{OH} or V _{OL} , -0.5V < V _{CM} < +5.5V		-200	+200	mV	1, 2, 3
R _I	Input Resistance	V _{CC} = 3.6V, -0.5V < V _{CM} < +5.5V, One input AC Gnd		5.0		KΩ	1, 2, 3
I _I	Input Current	V _{CC} = 3.6V, V _I = +5.5V Other Input = Gnd		0.0	+1.8	mA	1, 2, 3
		V _{CC} = 3.6V, V _I = -0.5V Other Input = Gnd		0.0	-1.8	mA	1, 2, 3
		V _{CC} = 0V, V _I = +5.5V Other Input = Gnd		0.0	+1.8	mA	1, 2, 3
		V _{CC} = 0V, V _I = -0.5V Other Input = Gnd		0.0	-1.8	mA	1, 2, 3
V _{OH}	Logical "1" Output Voltage	V _{CC} = 3.0V, V _{Diff} = +1V, I _O = -6.0mA		2.4		V	1, 2, 3
V _{OL}	Logical "0" Output Voltage	V _{CC} = 3.0V, V _{Diff} = -1V, I _O = 6.0mA			0.5	V	1, 2, 3
V _{IH}	Minimum Enable High Level Voltage		(1)	2.0		V	1, 2, 3
V _{IL}	Maximum Enable Low Level Voltage		(1)		0.8	V	1, 2, 3
I _{OZ}	Maximum TRI-STATE Output Leakage Current	V _{CC} = 3.6V, V _O = V _{CC} or Gnd Enable = V _{IL} , Enable = V _{IH}			±50	μA	1, 2, 3
I _{En}	Maximum Enable Input Current	V _{CC} = 3.6V, V _I = V _{CC} or Gnd			±1.0	μA	1, 2, 3
I _{CC}	Quiescent Power Supply Current	V _{CC} = 3.6V, No Load, En, En = V _{CC} or Gnd, -0.5V < V _{CM} < +5.5V			20	mA	1, 2, 3
I _{OS}	Output Short Circuit Current	V _{CC} = 3.0V/3.6V, V _O = 0V, V _{Diff} = +1V	(2)	-10	-70	mA	1, 2, 3

(1) Parameter tested Go-No-Go only.

(2) Short one output at a time to Gnd.

DS26LV32AQL Electrical Characteristics AC Parameters

The following conditions apply, unless otherwise specified.

AC: V_{CC} = 3.0/3.6V, C_L = 50pF

Parameter		Test Conditions	Notes	Min	Max	Units	Sub-groups
t _{PLH}	Input to Output Propagation Delay	V _{CM} = 1.5V	(1)	6.0	45	nS	9, 10, 11
t _{PHL}	Input to Output Propagation Delay	V _{CM} = 1.5V	(1)	6.0	45	nS	9, 10, 11
t _{SK1}	Skew tpHLD-tpLHD (same channel)				6.0	nS	9, 10, 11
t _{SK2}	Pin to Pin Skew (Same device)				6.0	nS	9, 10, 11
t _{PLZ}	Output Disable Time	2KΩ to V _{CC}	(2)		50	nS	9, 10, 11
t _{PZL}	Output Enable Time	2KΩ to V _{CC}	(2)		50	nS	9, 10, 11
t _{PHZ}	Output Disable Time	2KΩ to Gnd	(2)		50	nS	9, 10, 11
t _{PZH}	Output Enable Time	2KΩ to Gnd	(2)		50	nS	9, 10, 11

(1) Generator waveform is specified as follows: f = 1MHz, Duty Cycle = 50%, Z_O = 50Ω, t_R = t_F ≤ 6nS. Receiver inputs = 1V to 2V with measure points equal to 1.5V on the inputs to 1/2 V_{CC} on the outputs.

(2) Generator waveform is specified as follows: f = 1MHz, Duty Cycle = 50%, Z_O = 50Ω, t_R = t_F ≤ 6nS. En/ $\overline{\text{En}}$ inputs = 0V to 3V with measure points equal to 1.5V on the inputs, to 1/2 V_{CC} on the outputs for Z_L and Z_H, and (V_{OL} + 0.3V) for L_Z, and (V_{OH} - 0.3V) for H_Z.

REVISION HISTORY

Released	Revision	Section	Originator	Changes
3/01/06	*	New Release, Corporate format	L. Lytle	1 MDS data sheet converted into one Corp. data sheet format. MNDS26LV32A-X Rev 0A0 will be archived.
4/15/2013	A		TIS	Changed layout of National Data Sheet to TI format

PACKAGING INFORMATION

Orderable part number	Status (1)	Material type (2)	Package Pins	Package qty Carrier	RoHS (3)	Lead finish/ Ball material (4)	MSL rating/ Peak reflow (5)	Op temp (°C)	Part marking (6)
5962-9858501QFA	Active	Production	CFP (NAD) 16	19 TUBE	No	SNPB	Level-1-NA-UNLIM	-55 to 125	DS26LV32AW- QML Q 5962-98585 01QFA ACO 01QFA >T
DS26LV32AW-QML	Active	Production	CFP (NAD) 16	19 TUBE	No	Call TI	Call TI	-55 to 125	DS26LV32AW- QML Q 5962-98585 01QFA ACO 01QFA >T
DS26LV32AW-QML.A	Active	Production	CFP (NAD) 16	19 TUBE	No	SNPB	Level-1-NA-UNLIM	-55 to 125	DS26LV32AW- QML Q 5962-98585 01QFA ACO 01QFA >T

(1) **Status:** For more details on status, see our [product life cycle](#).

(2) **Material type:** When designated, preproduction parts are prototypes/experimental devices, and are not yet approved or released for full production. Testing and final process, including without limitation quality assurance, reliability performance testing, and/or process qualification, may not yet be complete, and this item is subject to further changes or possible discontinuation. If available for ordering, purchases will be subject to an additional waiver at checkout, and are intended for early internal evaluation purposes only. These items are sold without warranties of any kind.

(3) **RoHS values:** Yes, No, RoHS Exempt. See the [TI RoHS Statement](#) for additional information and value definition.

(4) **Lead finish/Ball material:** Parts may have multiple material finish options. Finish options are separated by a vertical ruled line. Lead finish/Ball material values may wrap to two lines if the finish value exceeds the maximum column width.

(5) **MSL rating/Peak reflow:** The moisture sensitivity level ratings and peak solder (reflow) temperatures. In the event that a part has multiple moisture sensitivity ratings, only the lowest level per JEDEC standards is shown. Refer to the shipping label for the actual reflow temperature that will be used to mount the part to the printed circuit board.

(6) **Part marking:** There may be an additional marking, which relates to the logo, the lot trace code information, or the environmental category of the part.

Multiple part markings will be inside parentheses. Only one part marking contained in parentheses and separated by a "~" will appear on a part. If a line is indented then it is a continuation of the previous line and the two combined represent the entire part marking for that device.

Important Information and Disclaimer: The information provided on this page represents TI's knowledge and belief as of the date that it is provided. TI bases its knowledge and belief on information provided by third parties, and makes no representation or warranty as to the accuracy of such information. Efforts are underway to better integrate information from third parties. TI has taken and continues to take reasonable steps to provide representative and accurate information but may not have conducted destructive testing or chemical analysis on incoming materials and chemicals. TI and TI suppliers consider certain information to be proprietary, and thus CAS numbers and other limited information may not be available for release.

In no event shall TI's liability arising out of such information exceed the total purchase price of the TI part(s) at issue in this document sold by TI to Customer on an annual basis.

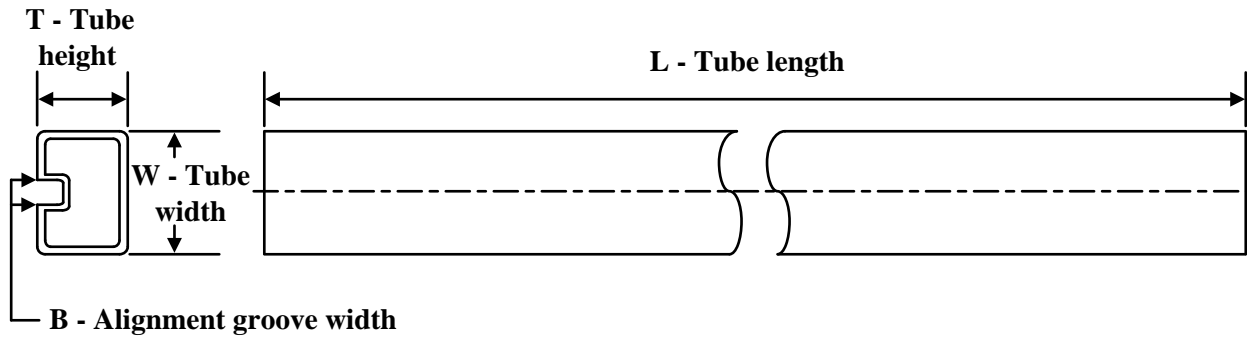
TUBE

*All dimensions are nominal

Device	Package Name	Package Type	Pins	SPQ	L (mm)	W (mm)	T (μm)	B (mm)
5962-9858501QFA	NAD	CFP	16	19	502	23	9398	9.78
DS26LV32AW-QML	NAD	CFP	16	19	502	23	9398	9.78
DS26LV32AW-QML.A	NAD	CFP	16	19	502	23	9398	9.78

NAD0016A

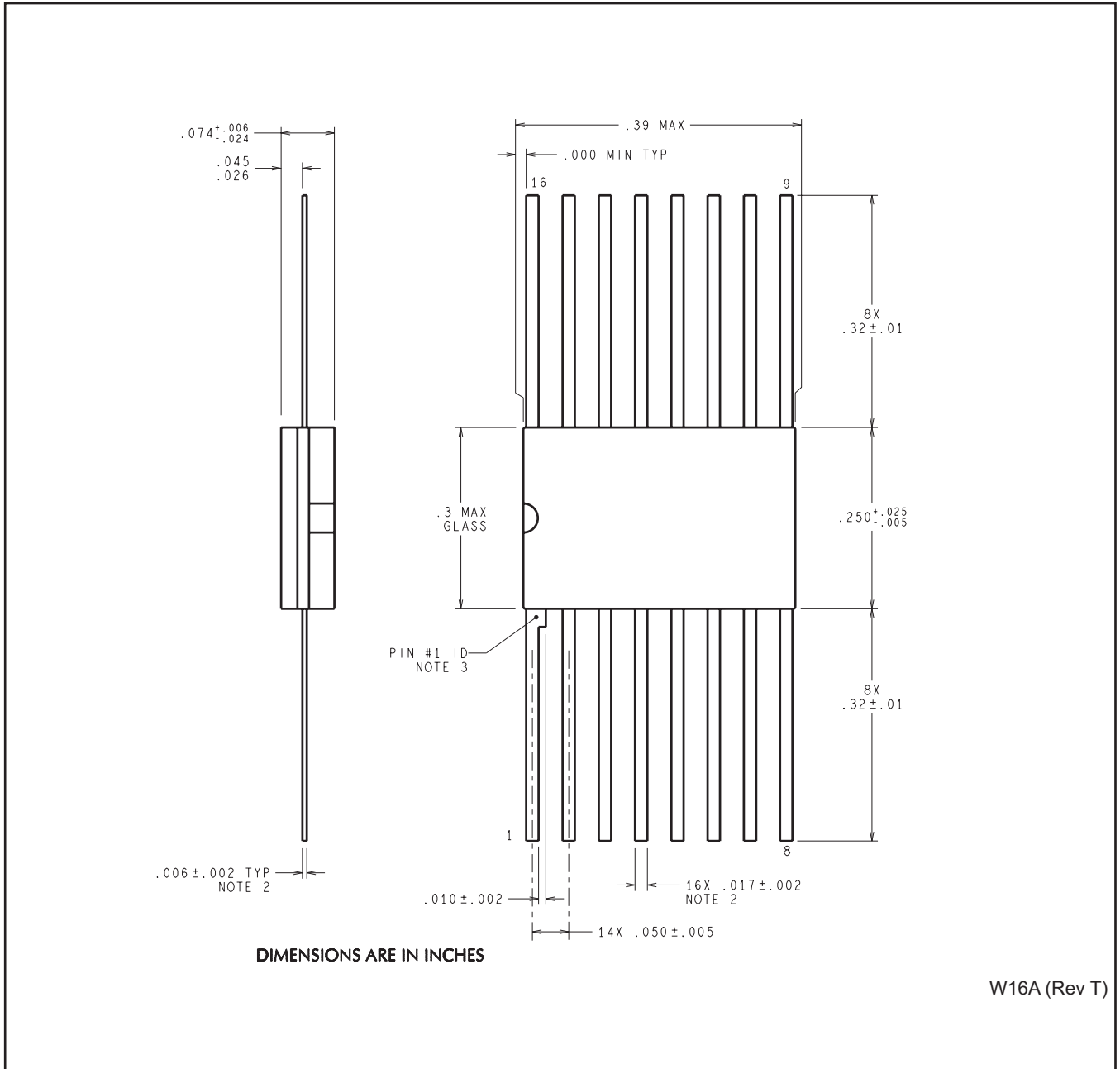

IMPORTANT NOTICE AND DISCLAIMER

TI PROVIDES TECHNICAL AND RELIABILITY DATA (INCLUDING DATASHEETS), DESIGN RESOURCES (INCLUDING REFERENCE DESIGNS), APPLICATION OR OTHER DESIGN ADVICE, WEB TOOLS, SAFETY INFORMATION, AND OTHER RESOURCES "AS IS" AND WITH ALL FAULTS, AND DISCLAIMS ALL WARRANTIES, EXPRESS AND IMPLIED, INCLUDING WITHOUT LIMITATION ANY IMPLIED WARRANTIES OF MERCHANTABILITY, FITNESS FOR A PARTICULAR PURPOSE OR NON-INFRINGEMENT OF THIRD PARTY INTELLECTUAL PROPERTY RIGHTS.

These resources are intended for skilled developers designing with TI products. You are solely responsible for (1) selecting the appropriate TI products for your application, (2) designing, validating and testing your application, and (3) ensuring your application meets applicable standards, and any other safety, security, regulatory or other requirements.

These resources are subject to change without notice. TI grants you permission to use these resources only for development of an application that uses the TI products described in the resource. Other reproduction and display of these resources is prohibited. No license is granted to any other TI intellectual property right or to any third party intellectual property right. TI disclaims responsibility for, and you fully indemnify TI and its representatives against any claims, damages, costs, losses, and liabilities arising out of your use of these resources.

TI's products are provided subject to [TI's Terms of Sale](#), [TI's General Quality Guidelines](#), or other applicable terms available either on ti.com or provided in conjunction with such TI products. TI's provision of these resources does not expand or otherwise alter TI's applicable warranties or warranty disclaimers for TI products. Unless TI explicitly designates a product as custom or customer-specified, TI products are standard, catalog, general purpose devices.

TI objects to and rejects any additional or different terms you may propose.

Copyright © 2026, Texas Instruments Incorporated

Last updated 10/2025