

DS26F31MQML Quad High Speed Differential Line Drivers

Check for Samples: [DS26F31MQML](#)

FEATURES

- Operation from Single +5.0V Supply
- Outputs Won't Load Line When $V_{CC} = 0V$
- Output Short Circuit Protection
- Meets the Requirements of EIA Standard RS-422
- High Output Drive Capability for 100 Ω Terminated Transmission Lines

DESCRIPTION

The DS26F31M is a quad differential line driver designed for digital data transmission over balanced lines. The DS26F31M meets all the requirements of EIA Standard RS-422 and Federal Standard 1020. It is designed to provide unipolar differential drive to twisted-pair or parallel-wire transmission lines.

The DS26F31M offers improved performance due to the use of state-of-the-art L-FAST bipolar technology. The L-FAST technology allows for higher speeds and lower currents by utilizing extremely short gate delay times. Thus, the DS26F31M features lower power, extended temperature range, and improved specifications.

The circuit provides an enable and disable function common to all four drivers. The DS26F31M features TRI-STATE outputs and logical OR-ed complementary enable inputs. The inputs are all LS compatible and are all one unit load.

The DS26F31M offers optimum performance when used with the DS26F32 Quad Differential Line Receiver.

Connection and Logic Diagrams

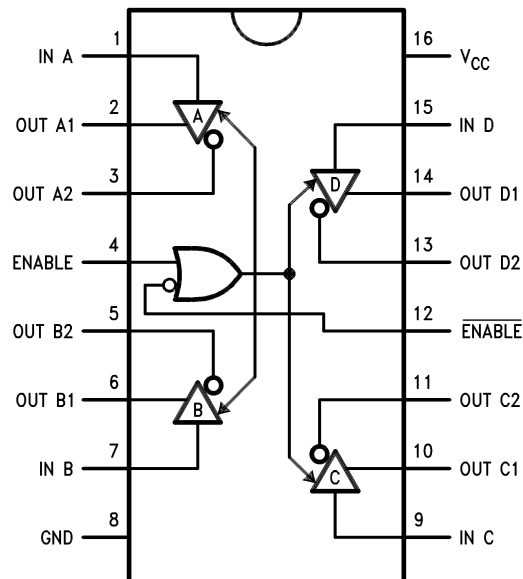

Figure 1. 16-Lead CDIP Package- Top View
See Package Numbers NFE0016A, NAD0016A, NAC0016A



Please be aware that an important notice concerning availability, standard warranty, and use in critical applications of Texas Instruments semiconductor products and disclaimers thereto appears at the end of this data sheet.

All trademarks are the property of their respective owners.

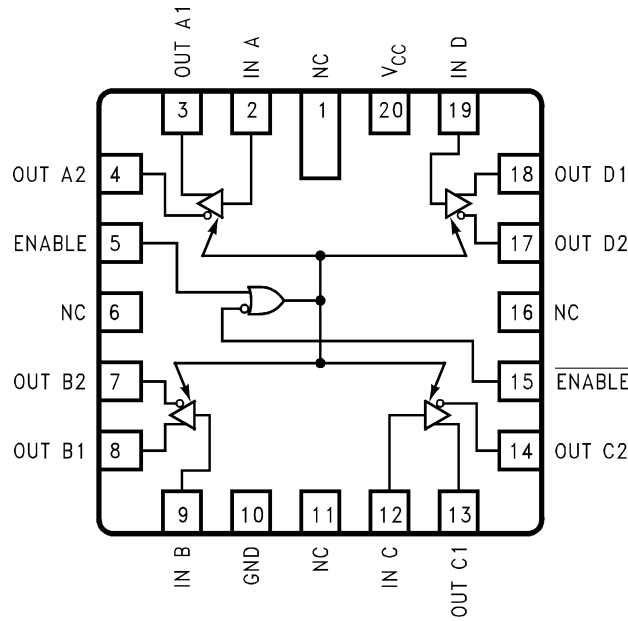

Figure 2. 20-Lead LCCC Package
See Package Number NAJ0020A

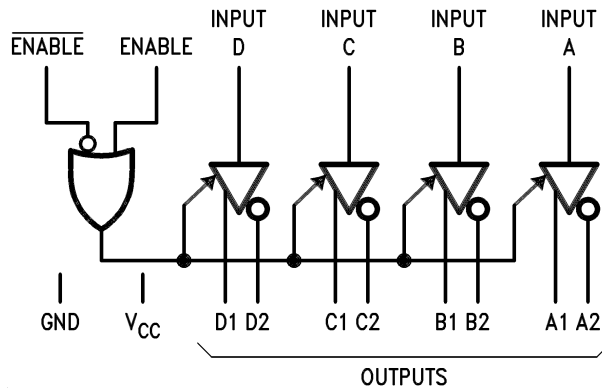

Figure 3. Logic Symbol



These devices have limited built-in ESD protection. The leads should be shorted together or the device placed in conductive foam during storage or handling to prevent electrostatic damage to the MOS gates.

Absolute Maximum Ratings⁽¹⁾

Storage Temperature Range	$-65^{\circ}\text{C} \leq T_A \leq +175^{\circ}\text{C}$
Lead Temperature (Soldering, 60 sec.)	300°C
Supply Voltage	7.0V
Input Voltage	7.0V
Output Voltage	5.5V
Maximum Power Dissipation at 25°C ⁽²⁾	450mW
Thermal Resistance	
θ_{JA}	
NFE0016A, derate above +25°C @ 11.4mW/°C	88°C/mW
NAD0016A, derate above +25°C @ 6.6 mW/°C	151°C/mW
NAJ0020A, derate above +25°C @ 12.3 mW/°C	81°C/mW
θ_{JC}	
NFE0016A	14°C/mW
NAD0016A	13°C/mW
NAJ0020A	15°C/mW

- (1) Absolute Maximum Ratings indicate limits beyond which damage to the device may occur. Operating Ratings indicate conditions for which the device is functional, but do not verify specific performance limits. For verified specifications and test conditions, see the Electrical Characteristics. The verified specifications apply only for the test conditions listed. Some performance characteristics may degrade when the device is not operated under the listed test conditions.
- (2) Power dissipation must be externally controlled at elevated temperatures.

Recommended Operating Range

Temperature	$-55^{\circ}\text{C} \leq T_A \leq +125^{\circ}\text{C}$
Supply Voltage	4.5V to 5.5V

Table 1. Radiation Features

DS26F31MJFQMLV	300 krad (Si)
DS26F31MWFQMLV	300 krad (Si)
DS26F31MWGFQMLV	300 krad (Si)

Quality Conformance Inspection

Table 2. Mil-Std-883, Method 5005 - Group A

Subgroup	Description	Temp °C
1	Static tests at	25
2	Static tests at	125
3	Static tests at	-55
4	Dynamic tests at	25
5	Dynamic tests at	125
6	Dynamic tests at	-55
7	Functional tests at	25
8A	Functional tests at	125
8B	Functional tests at	-55
9	Switching tests at	25
10	Switching tests at	125
11	Switching tests at	-55
12	Settling time at	25
13	Settling time at	125
14	Settling time at	-55

DS26F31M Electrical Characteristics DC Parameters ⁽¹⁾

Parameter		Test Conditions	Notes	Min	Max	Units	Sub-groups
V _{IH}	Logical "1" Input Voltage	V _{CC} = 4.5V	(2)	2.0		V	1, 2, 3
V _{IL}	Logical "0" Input Voltage	V _{CC} = 5.5V	(2)		0.8	V	1, 2, 3
V _{OH}	Logical "1" Output Voltage	V _{CC} = 4.5V, I _{OH} = -20mA, V _{IL} = 0.8V, V _{IH} = 2V		2.5		V	1, 2, 3
V _{OL}	Logical "0" Output Voltage	V _{CC} = 4.5V, I _{OL} = 20mA, V _{IL} = 0.8V, V _{IH} = 2V			0.5	V	1, 2, 3
I _{IH}	Logical "1" Input Current	V _{CC} = 5.5V, V _I = 2.7V	(3)	-2.0	20	μA	1, 2, 3
I _{IL}	Logical "0" Input Current	V _{CC} = 5.5V, V _I = 0.4V	(3)	100	-200	μA	1, 2, 3
I _I	Input Reverse Current	V _{CC} = 5.5V, V _I = 7V	(3)	-0.01	0.1	mA	1, 2, 3
I _{OZ}	TRI-STATE Output Current	V _{CC} = 5.5V, V _O = 0.5V			-20	μA	1, 2, 3
		V _{CC} = 5.5V, V _O = 2.5V			20	μA	1, 2, 3
V _I	Input Clamp Voltage	V _{CC} = 4.5V, I _I = -18mA			-1.5	V	1, 2, 3
I _{SC Min}	Output Short Circuit Current	V _{CC} = 5.5V, V _O = 0V		-30		mA	1, 2, 3
I _{SC Max}	Output Short Circuit Current	V _{CC} = 5.5V, V _O = 0V			-150	mA	1, 2, 3
I _{CC Dis}	Power Supply Current	V _{CC} = 5.5V, V _I = 0.8V or 2V, V _{En} = 0.8V, V _{En} = 2V			50	mA	1, 2, 3
I _{CC En}	Power Supply Current	V _{CC} = 5.5V, V _{En} = 2V, V _{En} = 0.8V			40	mA	1, 2, 3

- (1) Pre and post irradiation limits are identical to those listed under AC and DC electrical characteristics, except as listed in the Post Radiation Limits Table — if applicable. Radiation end point limits for the noted parameters are specified only for the conditions, as specified.
- (2) Parameter tested go-no-go only.
- (3) The minimum limits apply to device Class Q & V. The limits specified for the INPUT LOW CURRENT represents the numerical range in which this parameter will pass.

DS26F31M Electrical Characteristics AC Parameters - Propagation Delay Time

The following conditions apply, unless otherwise specified.

AC: V_{CC} = 5V, C_L = 50pF or equivalent impedance provided by diode load

Parameter		Test Conditions	Notes	Min	Max	Units	Sub-groups
t _{PLH}	Input to Output		(1)		16	nS	9
			(1)		24	nS	10, 11
		C _L = 30pF	(2)		15	nS	9
			(2)		23	nS	10, 11
t _{PHL}	Input to Output		(1)		17	nS	9
			(1)		25	nS	10, 11
		C _L = 30pF	(2)		15	nS	9
			(2)		23	nS	10, 11
t _{LZ}	Disable Time		(1)		38	nS	9
			(1)		56	nS	10, 11
		C _L = 10 pF	(2)		35	nS	9
			(2)		53	nS	10, 11
t _{HZ}	Disable Time		(1)		23	nS	9
			(1)		30	nS	10, 11
		C _L = 10 pF	(2)		20	nS	9
			(2)		27	nS	10, 11

- (1) Tested at 50pF, system capacitance exceed 10 and 30pF.
- (2) Testing at 50pF specifies limits at 10 and 30pF.

DS26F31M Electrical Characteristics AC Parameters - Propagation Delay Time (continued)

The following conditions apply, unless otherwise specified.

AC: $V_{CC} = 5V$, $C_L = 50pF$ or equivalent impedance provided by diode load

Parameter		Test Conditions	Notes	Min	Max	Units	Sub-groups
t_{ZL}	Enable Time		(1)		28	nS	9
			(1)		40	nS	10, 11
		$C_L = 30pF$	(2)		25	nS	9
			(2)		37	nS	10, 11
t_{ZH}	Enable Time		(1)		32	nS	9
			(1)		52	nS	10, 11
		$C_L = 30 pF$	(2)		30	nS	9
			(2)		50	nS	10, 11
Skew	Output to Output		(1)		6.0	nS	9
			(1)		9.0	nS	10, 11
		$C_L = 30pF$	(2)		4.5	nS	9
			(2)		7.0	nS	10, 11

DS26F31M Electrical Characteristics DC Drift Parameters

This section applies to -QMLV devices only and shall be read & recorded at $T_A = +25^\circ C$ before and after each burn-in & Subgroup B5, and shall not change by more than the limits indicated. The delta rejects shall be included in the PDA calculations.

Parameter		Test Conditions	Notes	Min	Max	Units	Sub-groups
V_{OH}	Logical "1" Output Voltage	$V_{CC} = 4.5V$, $I_{OH} = -20mA$, $V_{IL} = 0.8V$, $V_{IH} = 2V$.		-250	250	mV	1
V_{OL}	Logical "0" Output Voltage	$V_{CC} = 4.5V$, $I_{OL} = 20mA$, $V_{IL} = 0.8V$, $V_{IH} = 2V$.		-50	50	mV	1
$I_{CC\ En}$	Power Supply Current	$V_{CC} = 5.5V$, $V_I = 0.8V$ or $2V$, $V_{En} = 2V$, $V_{En} = 0.8V$.		-8.0	8.0	mA	1
$I_{CC\ Dis}$	Power Supply Current	$V_{CC} = 5.5V$, $V_I = 0.8V$ or $2V$, $V_{En} = 0.8V$, $V_{En} = 2V$.		-8.0	8.0	mA	1

TEST CIRCUIT AND TIMING WAVEFORMS

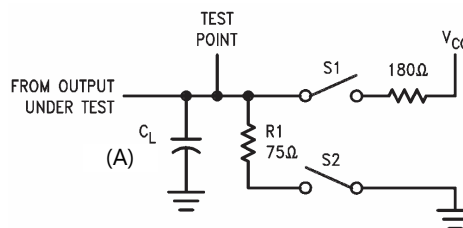

- A. Parameter tested go-no-go only.
 S1 and S2 of Load Circuit are closed except where shown.
 C_L includes probe and jig capacitance.

Figure 4. AC Load Test Circuit for TRI-STATE Outputs

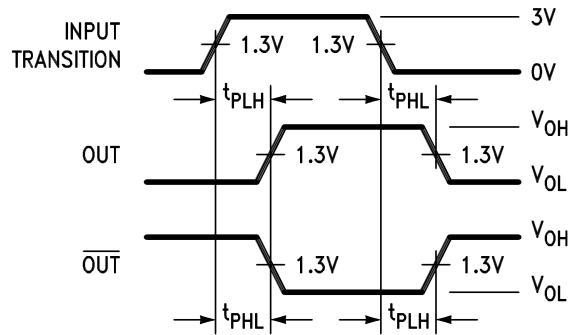

Pulse Generator for all Pulses: Rate \leq 1.0 MHz, $Z_0 = 50\Omega$, $t_r \leq 6.0$ ns, $t_f \leq 6.0$ ns.

Figure 5. Propagation Delay (1) (2)

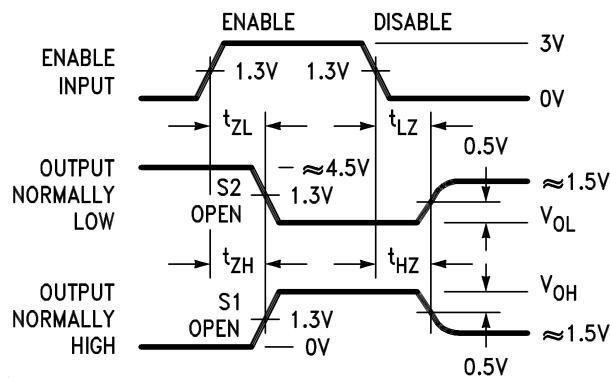

Pulse Generator for all Pulses: Rate \leq 1.0 MHz, $Z_0 = 50\Omega$, $t_r \leq 6.0$ ns, $t_f \leq 6.0$ ns.

Diagram shown for Enable Low. Switches S1 and S2 open.

Figure 6. Enable and Disable Times (2)

- (1) Absolute Maximum Ratings indicate limits beyond which damage to the device may occur. Operating Ratings indicate conditions for which the device is functional, but do not verify specific performance limits. For verified specifications and test conditions, see the Electrical Characteristics. The verified specifications apply only for the test conditions listed. Some performance characteristics may degrade when the device is not operated under the listed test conditions.
- (2) All currents into the device pins are positive; all currents out of the device pins are negative. All voltages are referenced to ground unless otherwise specified.

TYPICAL APPLICATION

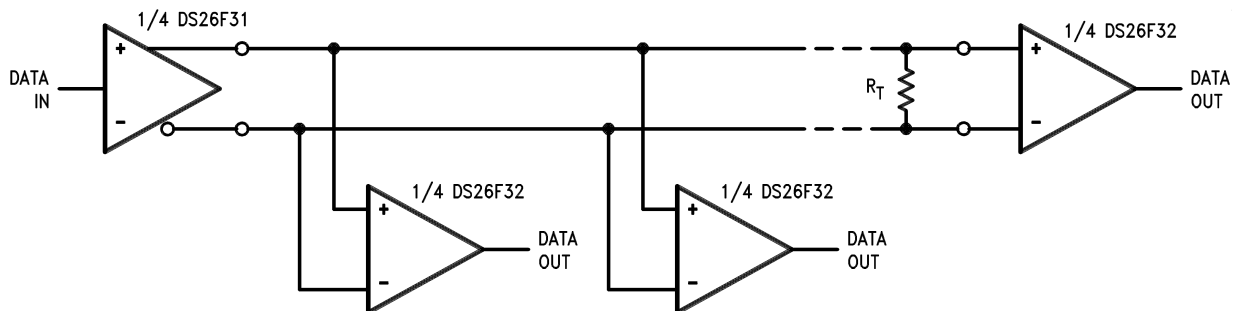

Figure 7. Typical Application

REVISION HISTORY

Released	Revision	Section	Originator	Changes
3/01/06	*	New Release, Corporate format	L. Lytle	1 MDS data sheet converted into one Corp. data sheet format. MNDS26F31M-X-RH Rev 0B0 will be archived.
4/15/2013	A			Changed layout of National Data Sheet to TI format

PACKAGING INFORMATION

Orderable part number	Status (1)	Material type (2)	Package Pins	Package qty Carrier	RoHS (3)	Lead finish/ Ball material (4)	MSL rating/ Peak reflow (5)	Op temp (°C)	Part marking (6)
5962-7802302M2A	Active	Production	LCCC (NAJ) 20	50 TUBE	Yes	Call TI	Level-1-NA-UNLIM	-55 to 125	DS26F31ME/ 883 Q 5962-78023 02M2A ACO 02M2A >T
5962-7802302MFA	Active	Production	CFP (NAD) 16	19 TUBE	No	SNPB	Level-1-NA-UNLIM	-55 to 125	DS26F31MW /883 Q 5962-78023 02MFA ACO 02MFA >T
5962F7802302VFA	Active	Production	CFP (NAD) 16	19 TUBE	No	SNPB	Level-1-NA-UNLIM	-55 to 125	DS26F31MWF QMLV Q 5962F78023 02VFA ACO 02VFA >T
DS26F31ME/883	Active	Production	LCCC (NAJ) 20	50 TUBE	Yes	Call TI	Level-1-NA-UNLIM	-55 to 125	DS26F31ME/ 883 Q 5962-78023 02M2A ACO 02M2A >T
DS26F31MW/883	Active	Production	CFP (NAD) 16	19 TUBE	No	SNPB	Level-1-NA-UNLIM	-55 to 125	DS26F31MW /883 Q 5962-78023 02MFA ACO 02MFA >T
DS26F31MWFQMLV	Active	Production	CFP (NAD) 16	19 TUBE	No	SNPB	Level-1-NA-UNLIM	-55 to 125	DS26F31MWF QMLV Q 5962F78023 02VFA ACO 02VFA >T
DS26F31MWFQMLV.A	Active	Production	CFP (NAD) 16	19 TUBE	No	SNPB	Level-1-NA-UNLIM	-55 to 125	DS26F31MWF QMLV Q 5962F78023 02VFA ACO 02VFA >T

(1) **Status:** For more details on status, see our [product life cycle](#).

(2) **Material type:** When designated, preproduction parts are prototypes/experimental devices, and are not yet approved or released for full production. Testing and final process, including without limitation quality assurance, reliability performance testing, and/or process qualification, may not yet be complete, and this item is subject to further changes or possible discontinuation. If available for ordering, purchases will be subject to an additional waiver at checkout, and are intended for early internal evaluation purposes only. These items are sold without warranties of any kind.

(3) **RoHS values:** Yes, No, RoHS Exempt. See the [TI RoHS Statement](#) for additional information and value definition.

(4) **Lead finish/Ball material:** Parts may have multiple material finish options. Finish options are separated by a vertical ruled line. Lead finish/Ball material values may wrap to two lines if the finish value exceeds the maximum column width.

(5) **MSL rating/Peak reflow:** The moisture sensitivity level ratings and peak solder (reflow) temperatures. In the event that a part has multiple moisture sensitivity ratings, only the lowest level per JEDEC standards is shown. Refer to the shipping label for the actual reflow temperature that will be used to mount the part to the printed circuit board.

(6) **Part marking:** There may be an additional marking, which relates to the logo, the lot trace code information, or the environmental category of the part.

Multiple part markings will be inside parentheses. Only one part marking contained in parentheses and separated by a "~" will appear on a part. If a line is indented then it is a continuation of the previous line and the two combined represent the entire part marking for that device.

Important Information and Disclaimer: The information provided on this page represents TI's knowledge and belief as of the date that it is provided. TI bases its knowledge and belief on information provided by third parties, and makes no representation or warranty as to the accuracy of such information. Efforts are underway to better integrate information from third parties. TI has taken and continues to take reasonable steps to provide representative and accurate information but may not have conducted destructive testing or chemical analysis on incoming materials and chemicals. TI and TI suppliers consider certain information to be proprietary, and thus CAS numbers and other limited information may not be available for release.

In no event shall TI's liability arising out of such information exceed the total purchase price of the TI part(s) at issue in this document sold by TI to Customer on an annual basis.

OTHER QUALIFIED VERSIONS OF DS26F31MQML, DS26F31MQML-SP :

- Military : [DS26F31MQML](#)
- Space : [DS26F31MQML-SP](#)

NOTE: Qualified Version Definitions:

- Military - QML certified for Military and Defense Applications
- Space - Radiation tolerant, ceramic packaging and qualified for use in Space-based application

TUBE

*All dimensions are nominal

Device	Package Name	Package Type	Pins	SPQ	L (mm)	W (mm)	T (μm)	B (mm)
5962-7802302M2A	NAJ	LCCC	20	50	470	11	3810	0
5962-7802302MFA	NAD	CFP	16	19	502	23	9398	9.78
5962F7802302VFA	NAD	CFP	16	19	502	23	9398	9.78
DS26F31ME/883	NAJ	LCCC	20	50	470	11	3810	0
DS26F31MW/883	NAD	CFP	16	19	502	23	9398	9.78
DS26F31MWFQMLV	NAD	CFP	16	19	502	23	9398	9.78
DS26F31MWFQMLV.A	NAD	CFP	16	19	502	23	9398	9.78

NAD0016A

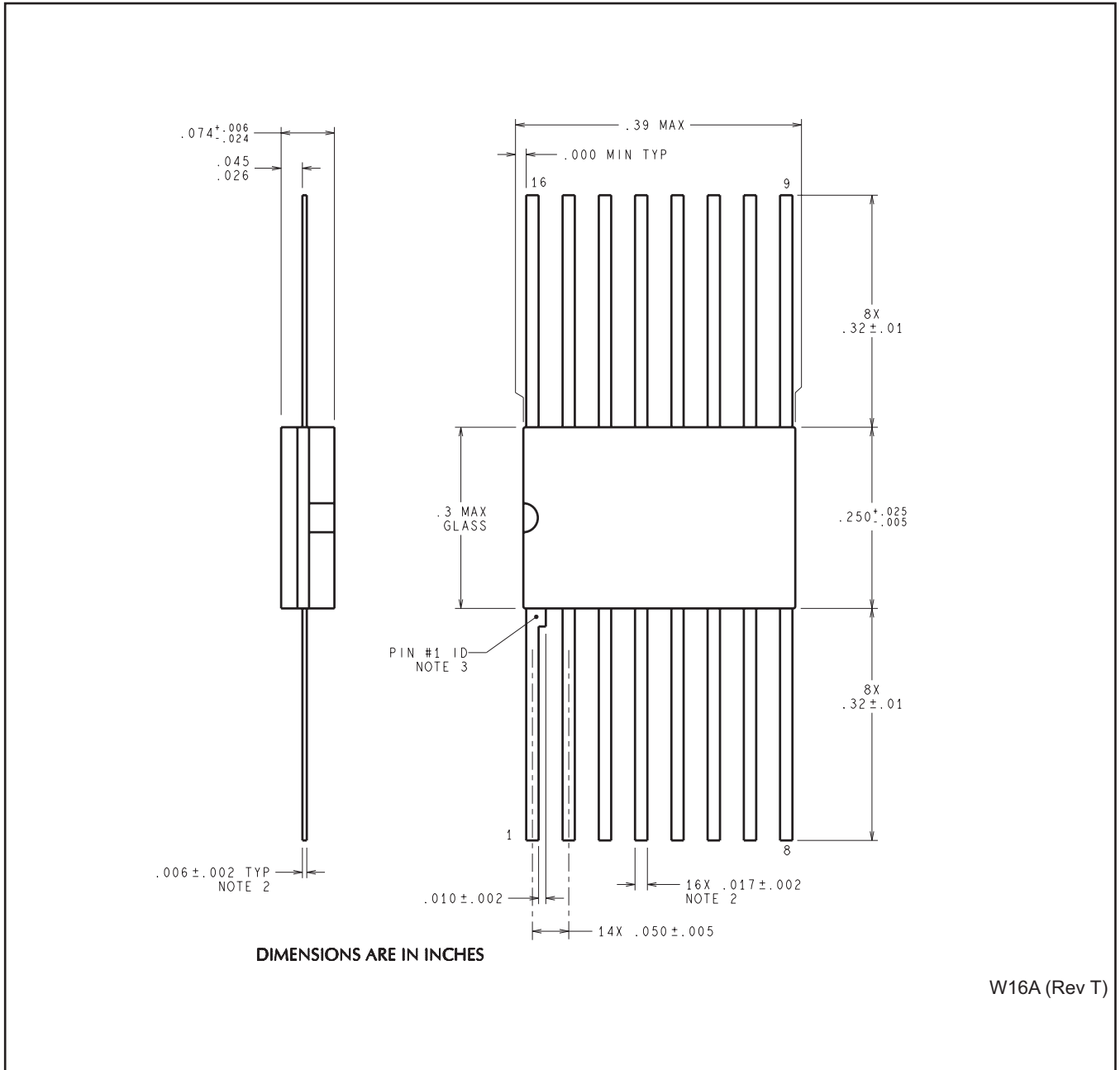

IMPORTANT NOTICE AND DISCLAIMER

TI PROVIDES TECHNICAL AND RELIABILITY DATA (INCLUDING DATASHEETS), DESIGN RESOURCES (INCLUDING REFERENCE DESIGNS), APPLICATION OR OTHER DESIGN ADVICE, WEB TOOLS, SAFETY INFORMATION, AND OTHER RESOURCES "AS IS" AND WITH ALL FAULTS, AND DISCLAIMS ALL WARRANTIES, EXPRESS AND IMPLIED, INCLUDING WITHOUT LIMITATION ANY IMPLIED WARRANTIES OF MERCHANTABILITY, FITNESS FOR A PARTICULAR PURPOSE OR NON-INFRINGEMENT OF THIRD PARTY INTELLECTUAL PROPERTY RIGHTS.

These resources are intended for skilled developers designing with TI products. You are solely responsible for (1) selecting the appropriate TI products for your application, (2) designing, validating and testing your application, and (3) ensuring your application meets applicable standards, and any other safety, security, regulatory or other requirements.

These resources are subject to change without notice. TI grants you permission to use these resources only for development of an application that uses the TI products described in the resource. Other reproduction and display of these resources is prohibited. No license is granted to any other TI intellectual property right or to any third party intellectual property right. TI disclaims responsibility for, and you fully indemnify TI and its representatives against any claims, damages, costs, losses, and liabilities arising out of your use of these resources.

TI's products are provided subject to [TI's Terms of Sale](#), [TI's General Quality Guidelines](#), or other applicable terms available either on [ti.com](#) or provided in conjunction with such TI products. TI's provision of these resources does not expand or otherwise alter TI's applicable warranties or warranty disclaimers for TI products. Unless TI explicitly designates a product as custom or customer-specified, TI products are standard, catalog, general purpose devices.

TI objects to and rejects any additional or different terms you may propose.

Copyright © 2026, Texas Instruments Incorporated

Last updated 10/2025