

# 具有高性能传感、保护和诊断功能的DRV3245E-Q1三相 0 级汽车栅极驱动器单元 (GDU)

## 1 特性

- 符合面向汽车应用的 AEC-Q100 标准：
  - 器件温度等级 0：
    - 40°C 至 +150°C, T<sub>A</sub>
- SafeTI™ 半导体组件
  - 根据 ISO 26262 标准的相应要求开发
- 4.5V 至 45V 工作电压范围
- 可编程峰值栅极驱动电流高达 1A
- 支持 100% 占空比的电荷泵栅极驱动器
- 电流分流放大器和相位比较器
  - A 器件：3 个电流分流放大器和三相比较器，具有状态，通过 SPI
  - B 器件：2 个电流分流放大器和三相比较器，具有实时监控器，通过数字引脚
- 高达 20kHz 的 3 PWM 或 6 PWM 输入控制
- 能够进行单 PWM 模式换向
- 支持 3.3V 和 5V 数字接口
- 串行外设接口 (SPI)
- 耐热增强型 48 引脚 HTQFP 封装
- 保护功能：
  - 内部稳压器、电池电压监控器
  - SPI CRC
  - 时钟监控器
  - 模拟内置自检
  - 可编程的死区时间控制
  - MOSFET 击穿保护
  - MOSFET V<sub>DS</sub> 过流监视器
  - 栅源电压实时监控器

- 过热警告

## 2 应用

- 高温 12V 汽车应用
  - 手自一体变速器和双离合变速器
  - 线控换挡
  - 分动箱和泵

## 3 说明

DRV3245E-Q1 器件是一款适用于三相电机驱动应用。此器件适用于高温汽车应用，根据 ISO 26262 标准中有关功能安全应用的相应要求设计而成。该器件具有三个半桥驱动器，每个驱动器都能够驱动高侧和低侧 N 沟道 MOSFET，同时还具有先进的 FET 保护和监控功能。电荷泵驱动器可在冷启动运行期间实现 100% 占空比并支持低电池电压。凭借所集成的电流检测放大器、相位比较器和基于 SPI 的配置省去了大多数外部和无源组件，从而减少了所需物料并减小了印刷电路板 (PCB) 空间。

DRV3245E-Q1 器件还为内部时钟集成了诊断和保护功能，并可提供常用系统诊断检查支持，二者皆可进行实例化并通过 SPI 进行报告。这种集成特性的灵活性使得该器件能够无缝集成到各种安全架构中。

### 器件信息 (1)

器件型号	封装	封装尺寸 (标称值)
DRV3245E-Q1	HTQFP (48)	7.00mm x 7.00mm

(1) 如需了解所有可用封装，请参阅数据表末尾的可订购产品附录。

### 简化原理图

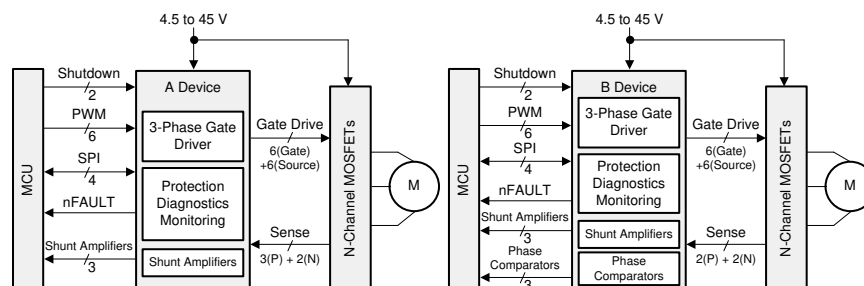

## 4 器件和文档支持

### 4.1 器件支持

#### 4.1.1 器件命名规则

图 1 显示了 DRV3245E-Q1 器件的完整可订购器件名称的解读图例



图 1. 器件命名规则

### 4.2 文档支持

相关文档请参见以下部分:

- 德州仪器 (TI), 《PowerPAD™ 热增强型封装》应用报告
- 德州仪器 (TI), 《PowerPAD™ 速成》应用报告
- 德州仪器 (TI), 《使用 MSP430 的传感器式三相 BLDC 电机控制》应用报告
- 德州仪器 (TI), 《了解 TI 电机栅极驱动器中的 IDRIVE 和 TDRIVE》应用报告

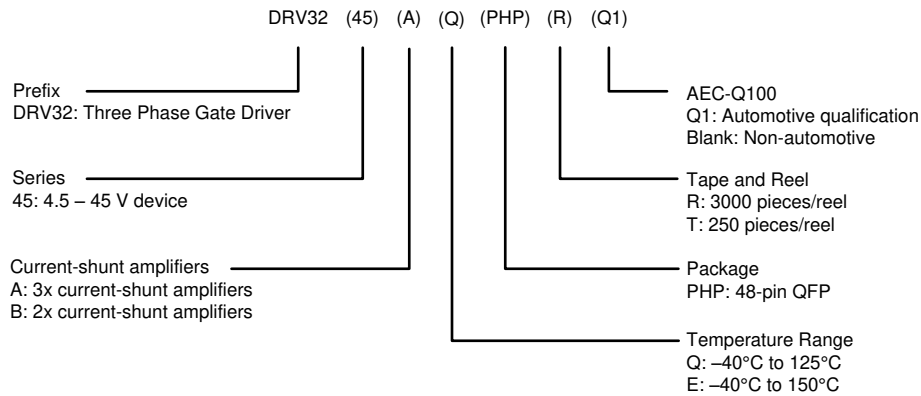
### 4.3 接收文档更新通知

要接收文档更新通知, 请导航至 TI.com.cn 上的器件产品文件夹。单击右上角的通知我 进行注册, 即可每周接收产品信息更改摘要。有关更改的详细信息, 请查看任何已修订文档中包含的修订历史记录。

### 4.4 社区资源

下列链接提供到 TI 社区资源的连接。链接的内容由各个分销商“按照原样”提供。这些内容并不构成 TI 技术规范, 并且不一定反映 TI 的观点; 请参阅 TI 的 《使用条款》。

**TI E2E™ Online Community TI's Engineer-to-Engineer (E2E) Community.** Created to foster collaboration among engineers. At e2e.ti.com, you can ask questions, share knowledge, explore ideas and help solve problems with fellow engineers.

**Design Support TI's Design Support** Quickly find helpful E2E forums along with design support tools and contact information for technical support.

### 4.5 商标

SafeTI, E2E are trademarks of Texas Instruments. All other trademarks are the property of their respective owners.

### 4.6 静电放电警告



ESD 可能会损坏该集成电路。德州仪器 (TI) 建议通过适当的预防措施处理所有集成电路。如果不遵守正确的处理措施和安装程序, 可能会损坏集成电路。

ESD 的损坏小至导致微小的性能降级, 大至整个器件故障。精密的集成电路可能更容易受到损坏, 这是因为非常细微的参数更改都可能会导致器件与其发布的规格不相符。

## 4.7 术语表

**SLYZ022** — *TI* 术语表。

这份术语表列出并解释术语、缩写和定义。

## 5 机械、封装和可订购信息

以下页面包含机械、封装和可订购信息。这些信息是指定器件的最新可用数据。数据如有变更，恕不另行通知，且不会对此文档进行修订。如需获取此产品说明书的浏览器版本，请查阅左侧的导航栏。

**PACKAGING INFORMATION**

Orderable part number	Status (1)	Material type (2)	Package   Pins	Package qty   Carrier	RoHS (3)	Lead finish/ Ball material (4)	MSL rating/ Peak reflow (5)	Op temp (°C)	Part marking (6)
<a href="#">DRV3245AEPHPRQ1</a>	Active	Production	HTQFP (PHP)   48	1000   LARGE T&R	Yes	NIPDAU	Level-3-260C-168 HR	-40 to 150	D3245AE
DRV3245AEPHPRQ1.A	Active	Production	HTQFP (PHP)   48	1000   LARGE T&R	Yes	NIPDAU	Level-3-260C-168 HR	-40 to 150	D3245AE
<a href="#">DRV3245BEPHPRQ1</a>	Active	Production	HTQFP (PHP)   48	1000   LARGE T&R	Yes	NIPDAU	Level-3-260C-168 HR	-40 to 150	D3245BE
DRV3245BEPHPRQ1.A	Active	Production	HTQFP (PHP)   48	1000   LARGE T&R	Yes	NIPDAU	Level-3-260C-168 HR	-40 to 150	D3245BE

(1) **Status:** For more details on status, see our [product life cycle](#).

(2) **Material type:** When designated, preproduction parts are prototypes/experimental devices, and are not yet approved or released for full production. Testing and final process, including without limitation quality assurance, reliability performance testing, and/or process qualification, may not yet be complete, and this item is subject to further changes or possible discontinuation. If available for ordering, purchases will be subject to an additional waiver at checkout, and are intended for early internal evaluation purposes only. These items are sold without warranties of any kind.

(3) **RoHS values:** Yes, No, RoHS Exempt. See the [TI RoHS Statement](#) for additional information and value definition.

(4) **Lead finish/Ball material:** Parts may have multiple material finish options. Finish options are separated by a vertical ruled line. Lead finish/Ball material values may wrap to two lines if the finish value exceeds the maximum column width.

(5) **MSL rating/Peak reflow:** The moisture sensitivity level ratings and peak solder (reflow) temperatures. In the event that a part has multiple moisture sensitivity ratings, only the lowest level per JEDEC standards is shown. Refer to the shipping label for the actual reflow temperature that will be used to mount the part to the printed circuit board.

(6) **Part marking:** There may be an additional marking, which relates to the logo, the lot trace code information, or the environmental category of the part.

Multiple part markings will be inside parentheses. Only one part marking contained in parentheses and separated by a "~" will appear on a part. If a line is indented then it is a continuation of the previous line and the two combined represent the entire part marking for that device.

**Important Information and Disclaimer:** The information provided on this page represents TI's knowledge and belief as of the date that it is provided. TI bases its knowledge and belief on information provided by third parties, and makes no representation or warranty as to the accuracy of such information. Efforts are underway to better integrate information from third parties. TI has taken and continues to take reasonable steps to provide representative and accurate information but may not have conducted destructive testing or chemical analysis on incoming materials and chemicals. TI and TI suppliers consider certain information to be proprietary, and thus CAS numbers and other limited information may not be available for release.

In no event shall TI's liability arising out of such information exceed the total purchase price of the TI part(s) at issue in this document sold by TI to Customer on an annual basis.

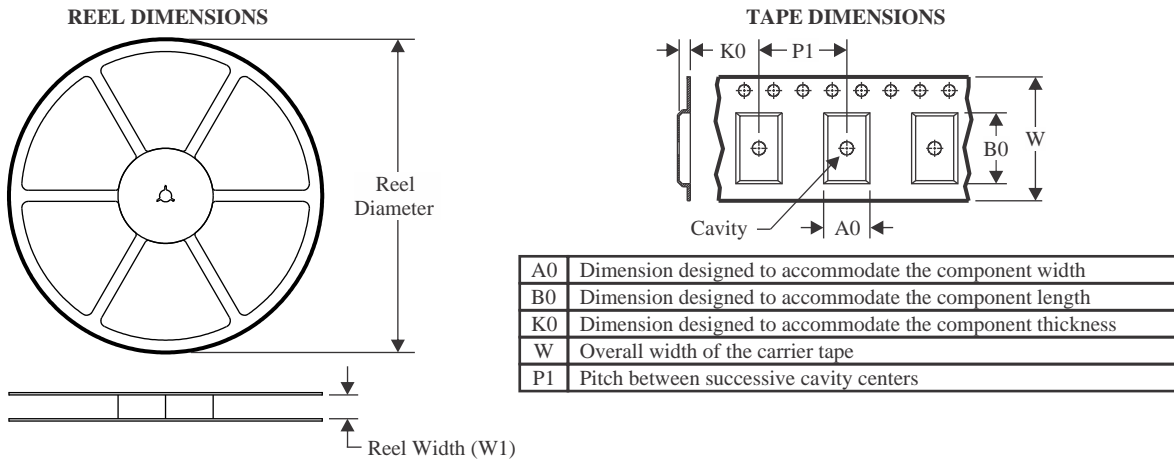
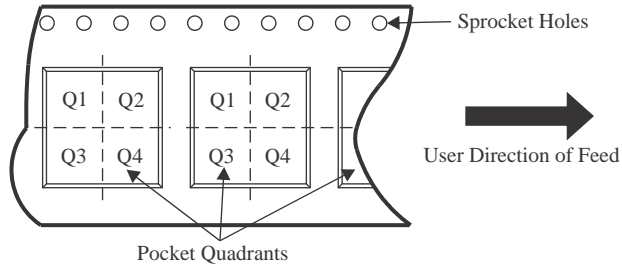
**TAPE AND REEL INFORMATION**

**QUADRANT ASSIGNMENTS FOR PIN 1 ORIENTATION IN TAPE**

\*All dimensions are nominal

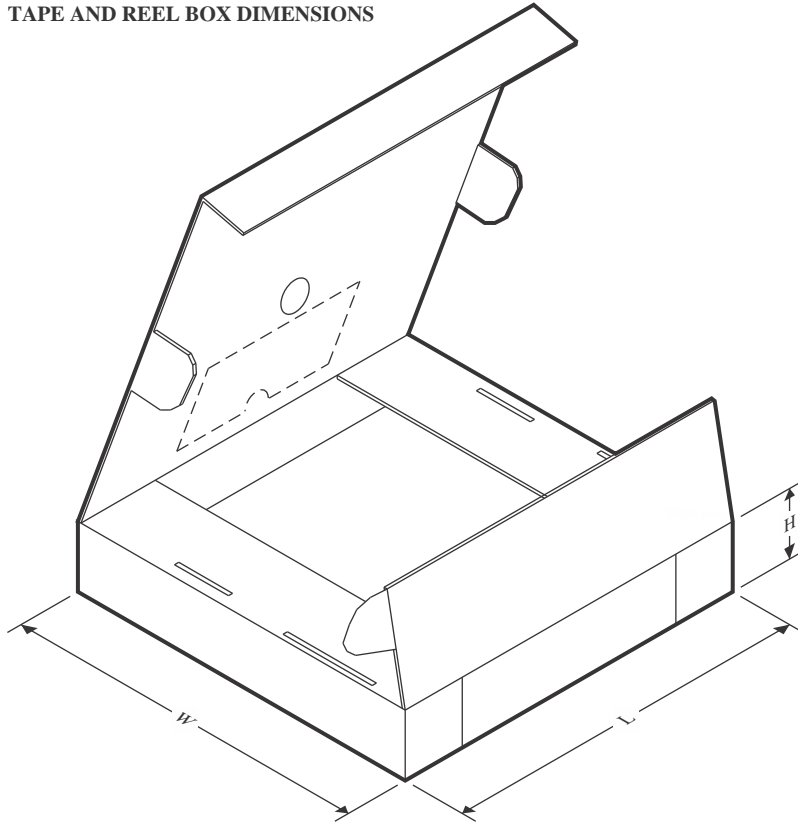
Device	Package Type	Package Drawing	Pins	SPQ	Reel Diameter (mm)	Reel Width W1 (mm)	A0 (mm)	B0 (mm)	K0 (mm)	P1 (mm)	W (mm)	Pin1 Quadrant
DRV3245AEPHPRQ1	HTQFP	PHP	48	1000	330.0	16.4	9.6	9.6	1.5	12.0	16.0	Q2
DRV3245BEPHPRQ1	HTQFP	PHP	48	1000	330.0	16.4	9.6	9.6	1.5	12.0	16.0	Q2

**TAPE AND REEL BOX DIMENSIONS**

\*All dimensions are nominal

Device	Package Type	Package Drawing	Pins	SPQ	Length (mm)	Width (mm)	Height (mm)
DRV3245AEPHPRQ1	HTQFP	PHP	48	1000	336.6	336.6	31.8
DRV3245BEPHPRQ1	HTQFP	PHP	48	1000	350.0	350.0	43.0

## GENERIC PACKAGE VIEW

**PHP 48**

**TQFP - 1.2 mm max height**

7 x 7, 0.5 mm pitch

QUAD FLATPACK

This image is a representation of the package family, actual package may vary.  
Refer to the product data sheet for package details.

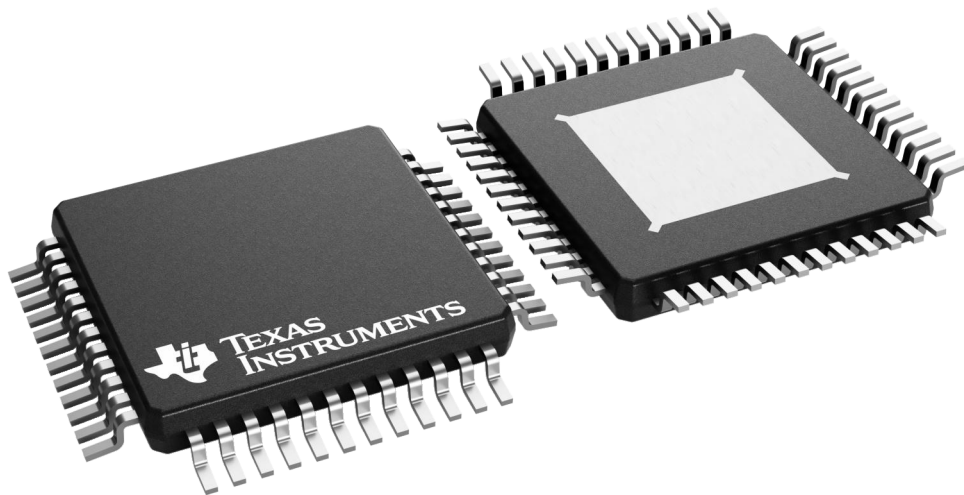

4226443/A

# PACKAGE OUTLINE

PHP0048G

PowerPAD™ HTQFP - 1.2 mm max height

PLASTIC QUAD FLATPACK

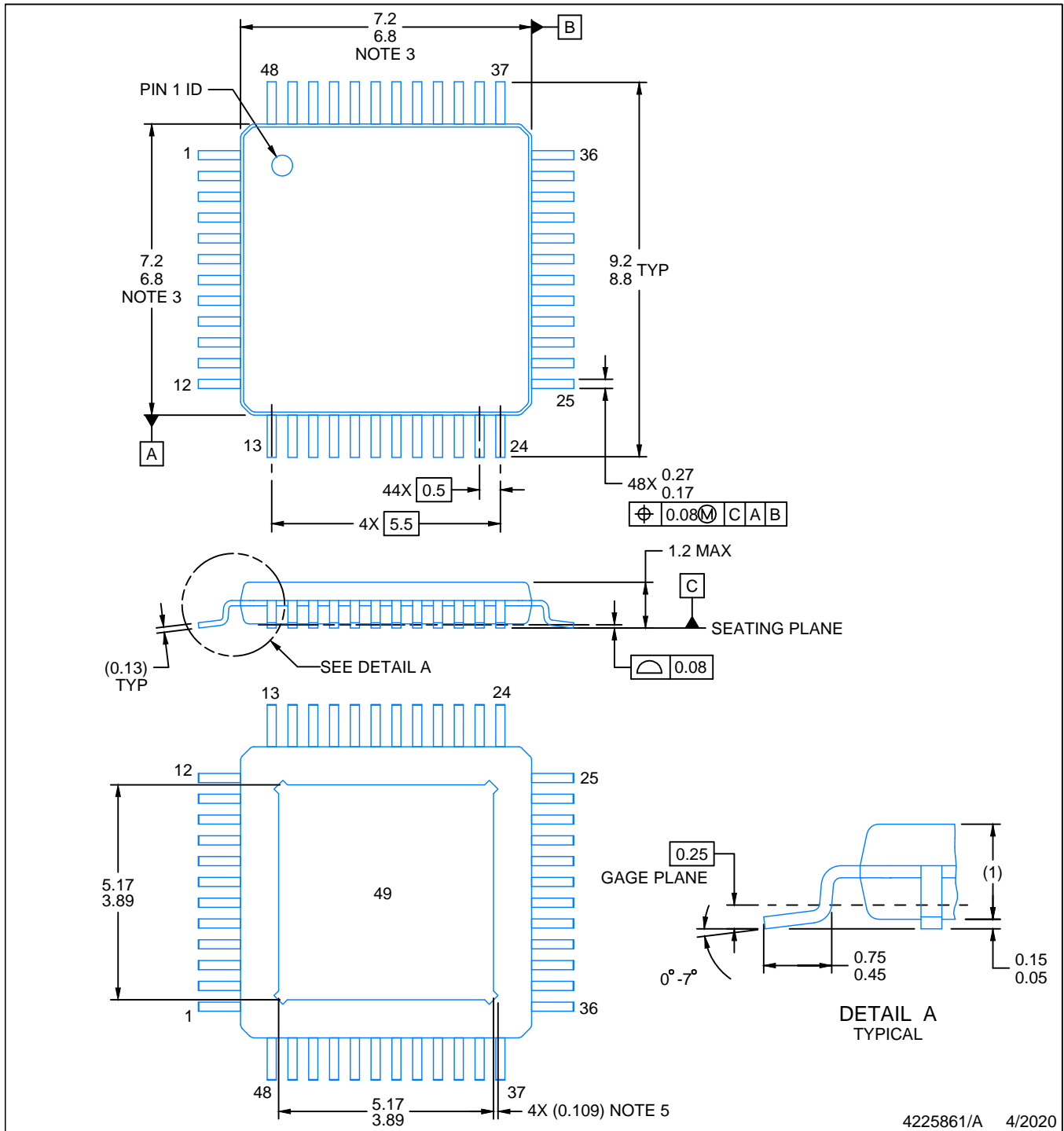

4225861/A 4/2020

**NOTES:**

PowerPAD is a trademark of Texas Instruments.

1. All linear dimensions are in millimeters. Any dimensions in parenthesis are for reference only. Dimensioning and tolerancing per ASME Y14.5M.
2. This drawing is subject to change without notice.
3. This dimension does not include mold flash, protrusions, or gate burrs. Mold flash, protrusions, or gate burrs shall not exceed 0.15 mm per side.
4. Reference JEDEC registration MS-026.
5. Feature may not be present.

# EXAMPLE BOARD LAYOUT

PHP0048G

PowerPAD™ HTQFP - 1.2 mm max height

PLASTIC QUAD FLATPACK

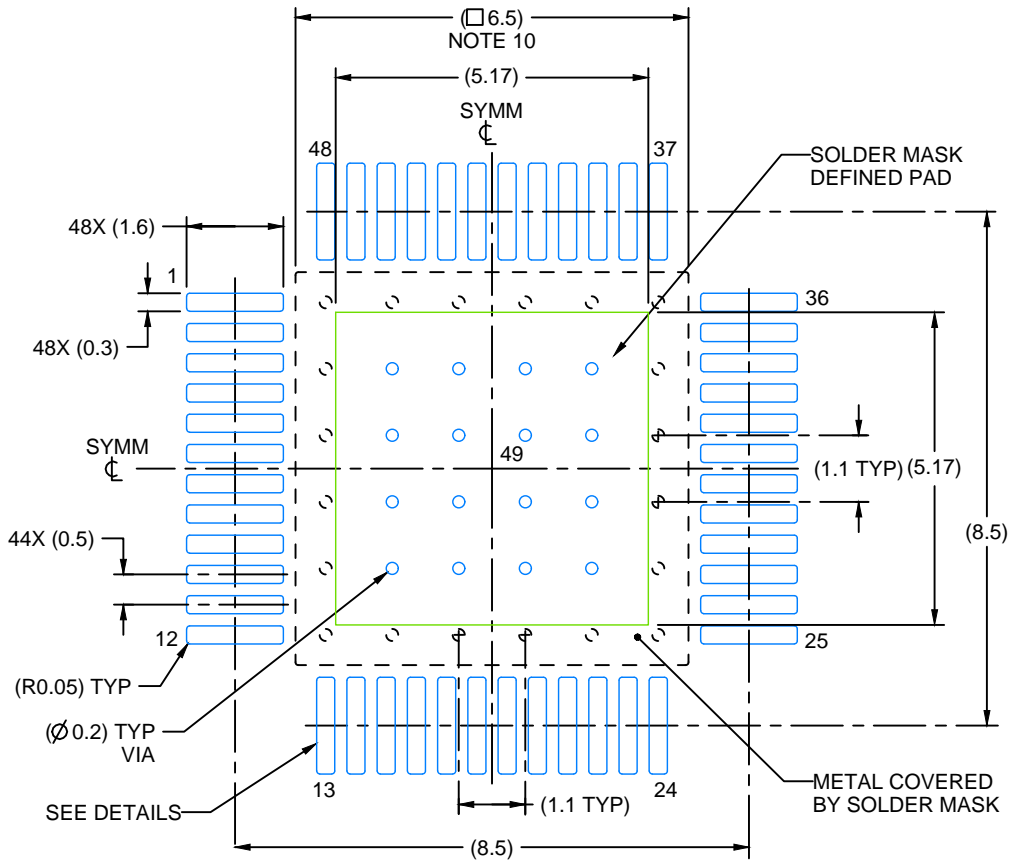

LAND PATTERN EXAMPLE  
EXPOSED METAL SHOWN  
SCALE:8X

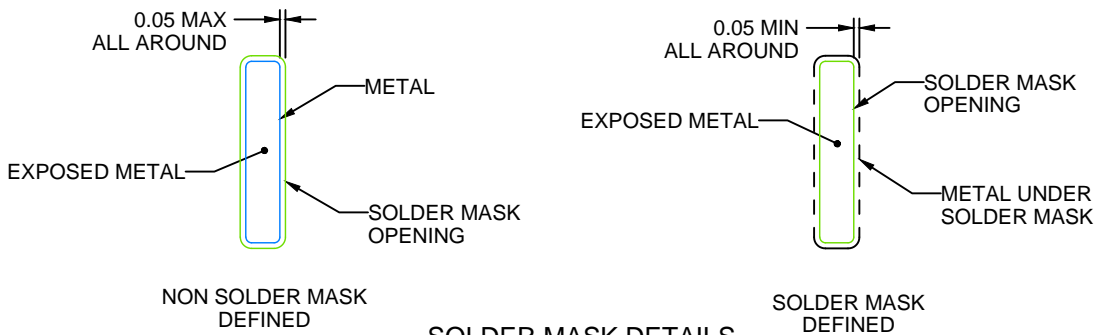

SOLDER MASK DETAILS

4225861/A 4/2020

NOTES: (continued)

6. Publication IPC-7351 may have alternate designs.
7. Solder mask tolerances between and around signal pads can vary based on board fabrication site.
8. This package is designed to be soldered to a thermal pad on the board. See technical brief, Powerpad thermally enhanced package, Texas Instruments Literature No. SLMA002 ([www.ti.com/lit/slma002](http://www.ti.com/lit/slma002)) and SLMA004 ([www.ti.com/lit/slma004](http://www.ti.com/lit/slma004)).
9. Vias are optional depending on application, refer to device data sheet. It is recommended that vias under paste be filled, plugged or tented.
10. Size of metal pad may vary due to creepage requirement.

# EXAMPLE STENCIL DESIGN

PHP0048G

PowerPAD™ HTQFP - 1.2 mm max height

PLASTIC QUAD FLATPACK

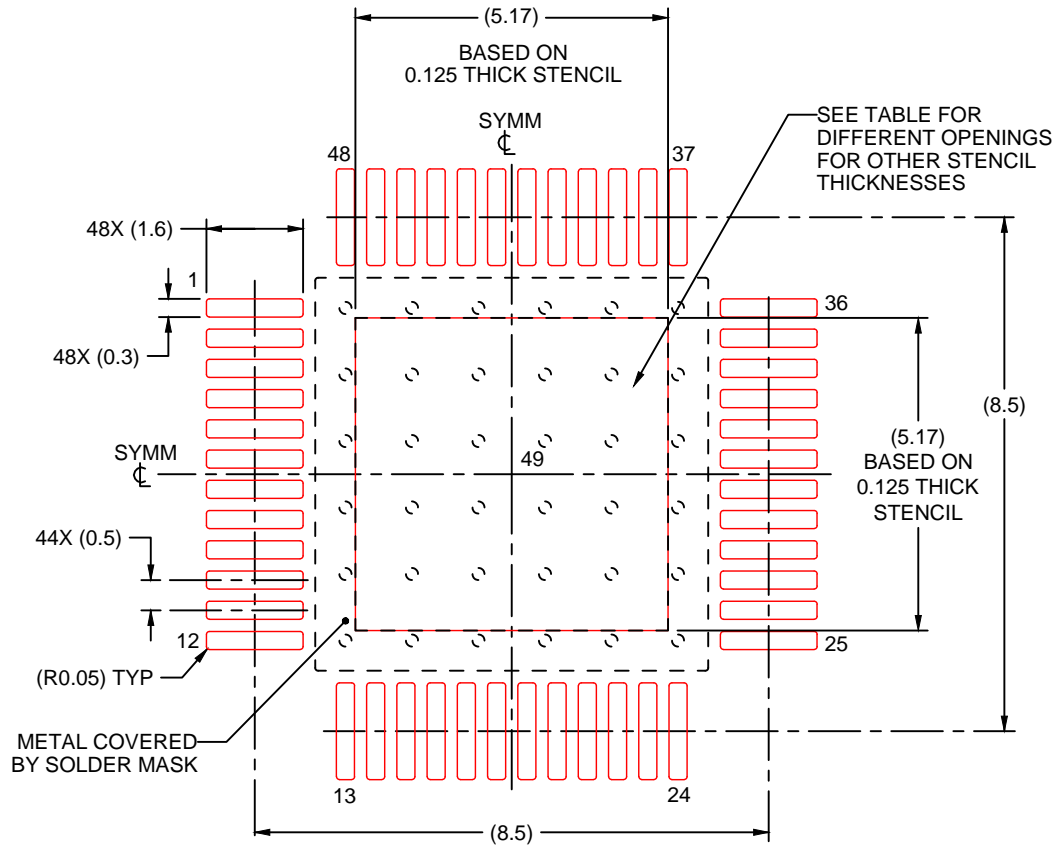

SOLDER PASTE EXAMPLE  
EXPOSED PAD  
100% PRINTED SOLDER COVERAGE BY AREA  
SCALE:8X

STENCIL THICKNESS	SOLDER STENCIL OPENING
0.1	5.78 X 5.78
0.125	5.17 X 5.17 (SHOWN)
0.150	4.72 X 4.72
0.175	4.37 X 4.37

4225861/A 4/2020

NOTES: (continued)

11. Laser cutting apertures with trapezoidal walls and rounded corners may offer better paste release. IPC-7525 may have alternate design recommendations.
12. Board assembly site may have different recommendations for stencil design.

# PHP0048N

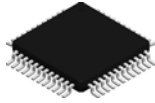

# PACKAGE OUTLINE

## PowerPAD™ HTQFP - 1.2 mm max height

PLASTIC QUAD FLATPACK

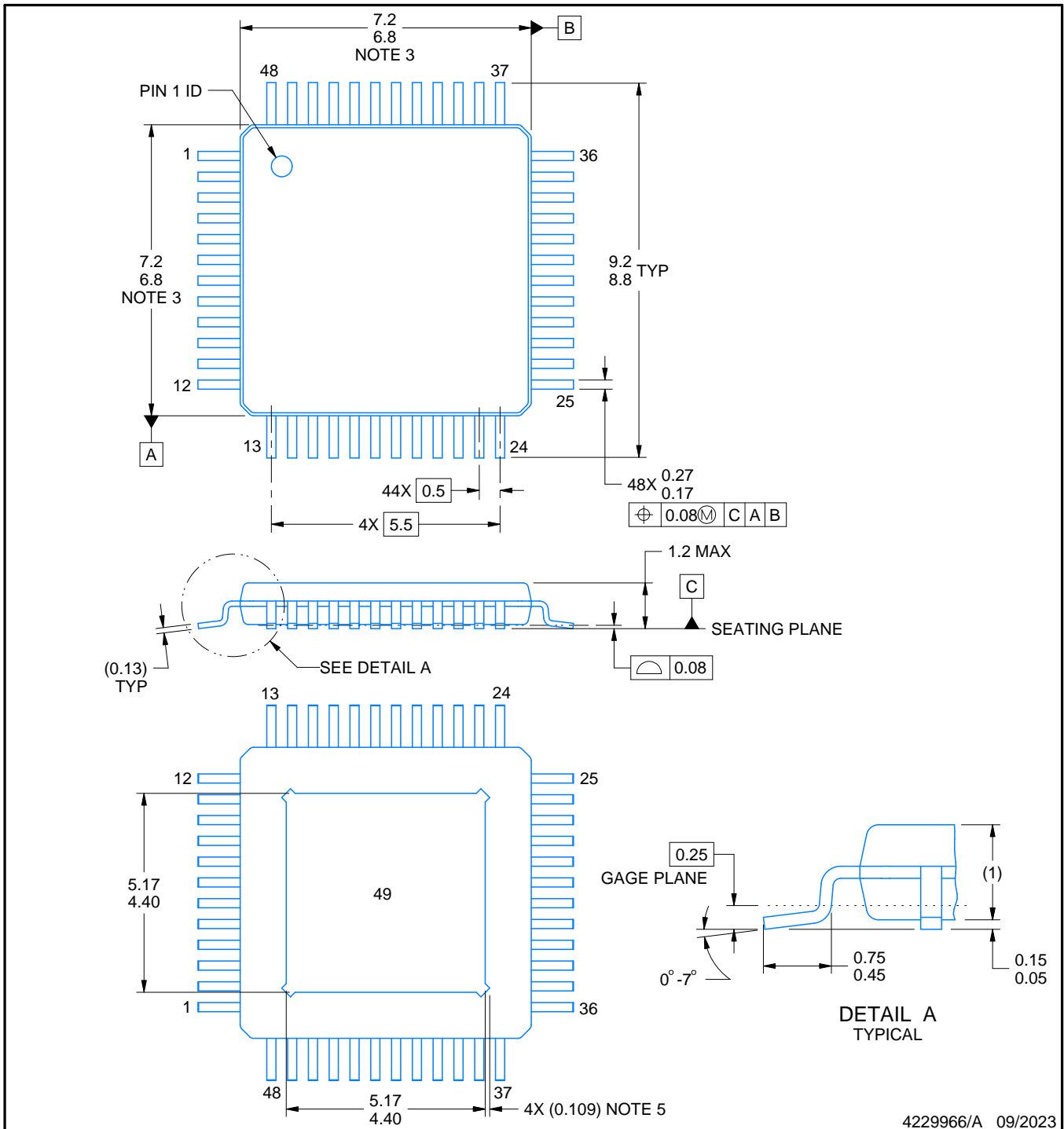

4229966/A 09/2023

**NOTES:**

PowerPAD is a trademark of Texas Instruments.

1. All linear dimensions are in millimeters. Any dimensions in parenthesis are for reference only. Dimensioning and tolerancing per ASME Y14.5M.
2. This drawing is subject to change without notice.
3. This dimension does not include mold flash, protrusions, or gate burrs. Mold flash, protrusions, or gate burrs shall not exceed 0.15 mm per side.
4. Reference JEDEC registration MS-026.
5. Feature may not be present.

# EXAMPLE BOARD LAYOUT

PHP0048N

PowerPAD™ HTQFP - 1.2 mm max height

PLASTIC QUAD FLATPACK

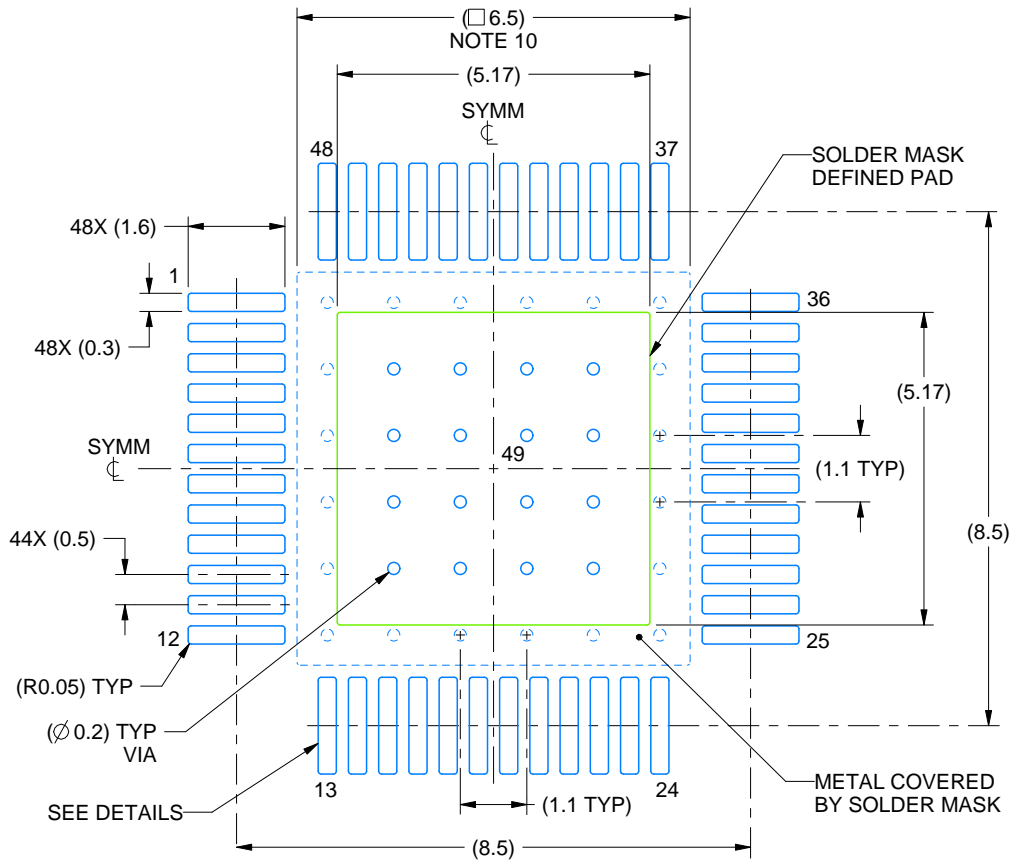

LAND PATTERN EXAMPLE  
EXPOSED METAL SHOWN  
SCALE:8X

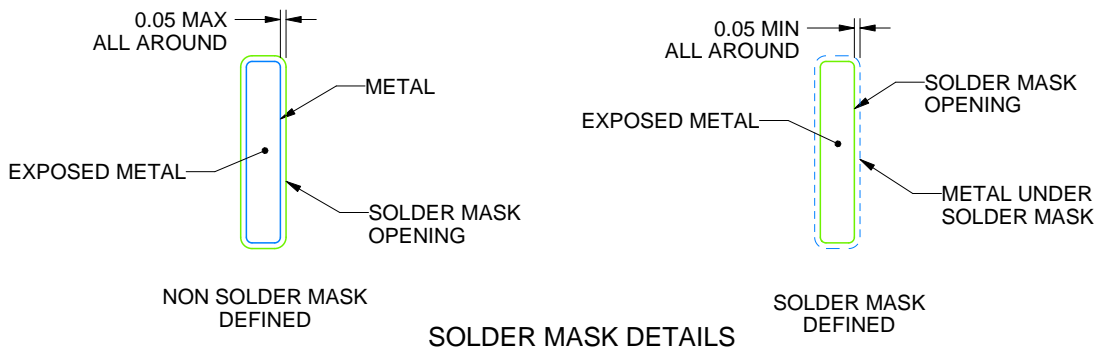

4229966/A 09/2023

NOTES: (continued)

6. Publication IPC-7351 may have alternate designs.
7. Solder mask tolerances between and around signal pads can vary based on board fabrication site.
8. This package is designed to be soldered to a thermal pad on the board. See technical brief, Powerpad thermally enhanced package, Texas Instruments Literature No. SLMA002 ([www.ti.com/lit/slma002](http://www.ti.com/lit/slma002)) and SLMA004 ([www.ti.com/lit/slma004](http://www.ti.com/lit/slma004)).
9. Vias are optional depending on application, refer to device data sheet. It is recommended that vias under paste be filled, plugged or tented.
10. Size of metal pad may vary due to creepage requirement.

# EXAMPLE STENCIL DESIGN

PHP0048N

PowerPAD™ HTQFP - 1.2 mm max height

PLASTIC QUAD FLATPACK

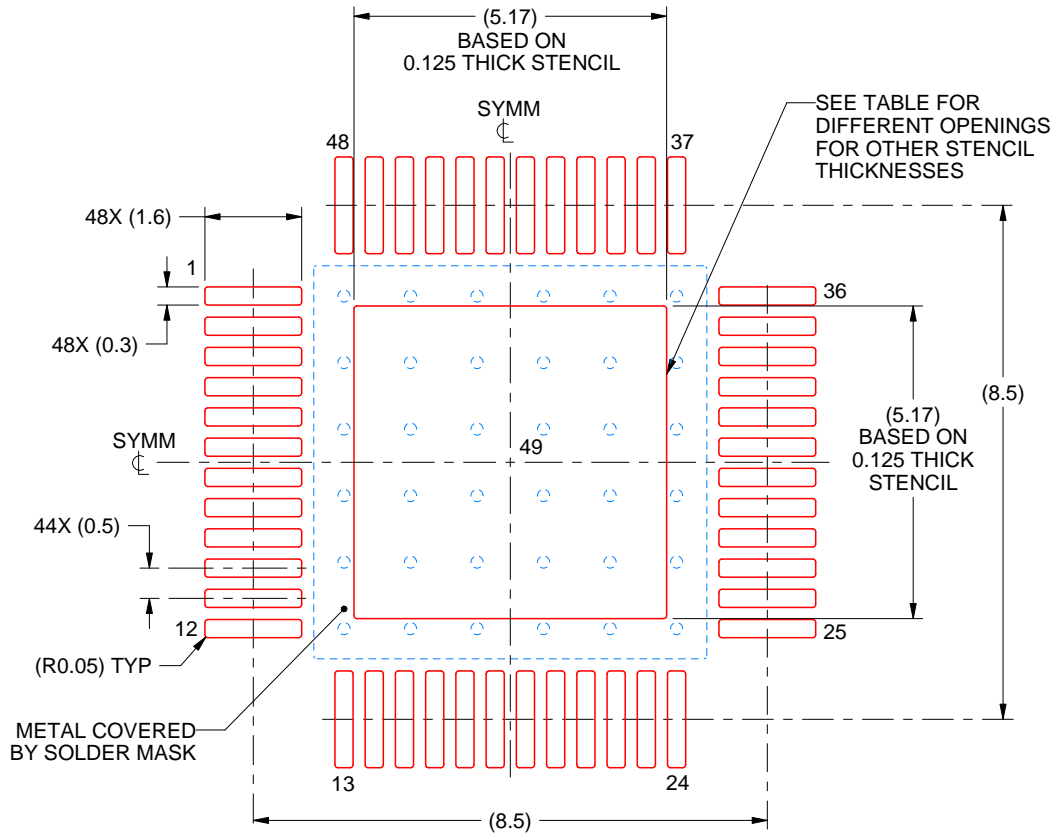

SOLDER PASTE EXAMPLE  
EXPOSED PAD  
100% PRINTED SOLDER COVERAGE BY AREA  
SCALE:8X

STENCIL THICKNESS	SOLDER STENCIL OPENING
0.1	5.78 X 5.78
0.125	5.17 X 5.17 (SHOWN)
0.150	4.72 X 4.72
0.175	4.37 X 4.37

4229966/A 09/2023

NOTES: (continued)

11. Laser cutting apertures with trapezoidal walls and rounded corners may offer better paste release. IPC-7525 may have alternate design recommendations.
12. Board assembly site may have different recommendations for stencil design.

## 重要通知和免责声明

TI“按原样”提供技术和可靠性数据（包括数据表）、设计资源（包括参考设计）、应用或其他设计建议、网络工具、安全信息和其他资源，不保证没有瑕疵且不做任何明示或暗示的担保，包括但不限于对适销性、与某特定用途的适用性或不侵犯任何第三方知识产权的暗示担保。

这些资源可供使用 TI 产品进行设计的熟练开发人员使用。您将自行承担以下全部责任：(1) 针对您的应用选择合适的 TI 产品，(2) 设计、验证并测试您的应用，(3) 确保您的应用满足相应标准以及任何其他安全、安保法规或其他要求。

这些资源如有变更，恕不另行通知。TI 授权您仅可将这些资源用于研发本资源所述的 TI 产品的相关应用。严禁以其他方式对这些资源进行复制或展示。您无权使用任何其他 TI 知识产权或任何第三方知识产权。对于因您对这些资源的使用而对 TI 及其代表造成的任何索赔、损害、成本、损失和债务，您将全额赔偿，TI 对此概不负责。

TI 提供的产品受 [TI 销售条款](#)、[TI 通用质量指南](#) 或 [ti.com](#) 上其他适用条款或 TI 产品随附的其他适用条款的约束。TI 提供这些资源并不会扩展或以其他方式更改 TI 针对 TI 产品发布的适用的担保或担保免责声明。除非德州仪器 (TI) 明确将某产品指定为定制产品或客户特定产品，否则其产品均为按确定价格收入目录的标准通用器件。

TI 反对并拒绝您可能提出的任何其他或不同的条款。

版权所有 © 2026，德州仪器 (TI) 公司

最后更新日期：2025 年 10 月