

DRV2510-Q1 适用于螺线管和音圈且具有集成诊断的 3A 汽车类触觉驱动器

1 特性

- 符合面向汽车应用的 AEC-Q100 标准：
 - 温度等级 1：-40 °C 至 125 °C、T_A
- 宽工作电压范围 (4.5V 至 18V)
- 集成负载突降保护 (40V)
- 大电流驱动 (峰值电流达 3A)
- 低 R_{DS(on)}，全 H 桥输出
- 集成型诊断
- 集成故障保护
 - 40V 负载突降保护符合 ISO-7637-2 标准
 - 短路保护
 - 过温保护
 - 过压和欠压保护
 - 故障报告
- 模拟输入
- I²C 通信
- 专用中断引脚
- ISO9000：已通过 2002 TS16949 认证

2 应用

- 电磁执行器驱动器
 - 音圈
 - 螺线管
- 机械按钮更换
- 汽车类触觉应用
 - 信息娱乐
 - 中央控制台
 - 方向盘
 - 车门板
 - 座椅

3 说明

DRV2510-Q1 器件是一款专为电感负载 (例如, 螺线管和音圈) 而设计的大电流触觉驱动器。

输出级含一个完整 H 桥, 能够提供 3A 峰值电流。

DRV2510-Q1 器件提供欠压闭锁、过流保护和过热保护等多种保护功能。

DRV2510-Q1 器件符合汽车类产品标准。集成的负载突降保护能够缩减外部电压钳位电路的成本与尺寸, 板载负载诊断功能能够通过数字接口报告传动器状态。

器件信息

器件型号	封装 ⁽¹⁾	封装尺寸 (标称值)
DRV2510-Q1	HTSSOP (16)	5.00 mm x 4.40 mm

(1) 如需了解所有可用封装, 请参阅数据表末尾的可订购产品附录。

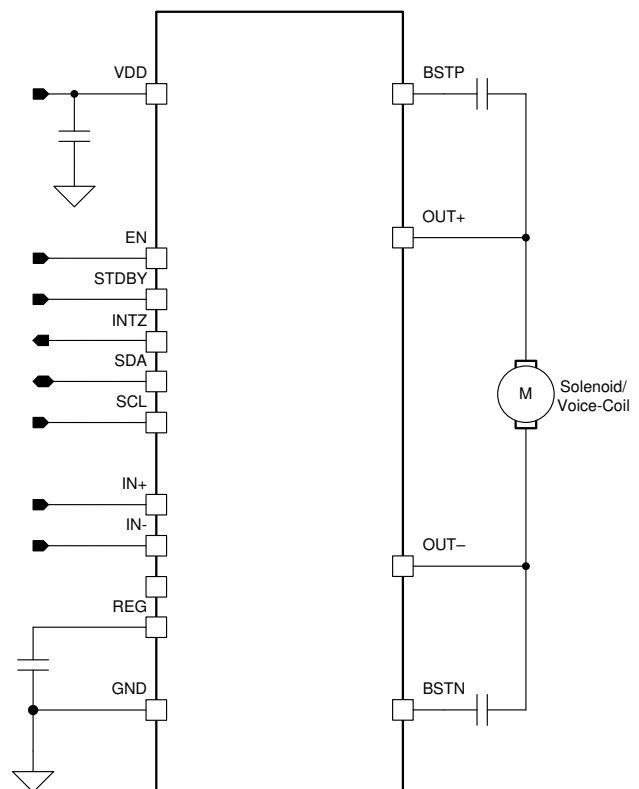

简化原理图



Table of Contents

1 特性	1	7.5 Programming.....	16
2 应用	1	7.6 Register Map.....	19
3 说明	1	8 Application and Implementation	22
4 Revision History	2	8.1 Application Information.....	22
5 Pin Configuration and Functions	4	8.2 Typical Applications.....	22
6 Specifications	5	9 Power Supply Recommendations	26
6.1 Absolute Maximum Ratings.....	5	10 Layout	26
6.2 ESD Ratings.....	5	10.1 Layout Guidelines.....	26
6.3 Recommended Operating Conditions.....	5	10.2 Layout Example.....	26
6.4 Thermal Information.....	5	11 Device and Documentation Support	27
6.5 Electrical Characteristics.....	6	11.1 Device Support.....	27
6.6 Timing Requirements.....	8	11.2 接收文档更新通知.....	27
6.7 Switching Characteristics.....	8	11.3 支持资源.....	27
6.8 Typical Characteristics.....	9	11.4 Trademarks.....	27
7 Detailed Description	10	11.5 静电放电警告.....	27
7.1 Overview.....	10	11.6 术语表.....	27
7.2 Functional Block Diagram.....	10	12 Mechanical, Packaging, and Orderable Information	27
7.3 Feature Description.....	11		
7.4 Device Functional Modes.....	15		

4 Revision History

注：以前版本的页码可能与当前版本的页码不同

Changes from Revision C (May 2020) to Revision D (November 2023)	Page
• 更新了整个文档中的表格、图和交叉参考的编号格式.....	1

Changes from Revision B (September 2016) to Revision C (May 2020)	Page
• 将汽车特性移至“特性”列表顶部.....	1
• Added Junction temperature to the <i>Absolute Maximum Ratings</i>	5
• Changed the <i>ESD Ratings</i> table.....	5
• Added INTZ Report to the <i>Electrical Characteristics</i> table.....	6
• Changed 图 7-1.....	11
• Changed From: "The load diagnostic function runs on de-assertion" To: "The load diagnostic function runs on assertion" in the <i>Load Diagnostics</i> section.....	12
• Added the <i>Protection and Monitoring</i> section.....	14
• Changed From: "NRST pin..." To: "EN pin..." in the <i>Operation in Shutdown Mode</i> section.....	15
• Changed From: When EN is asserted (logic low) To: When EN is de-asserted (logic low) in the <i>Operation in Shutdown Mode</i> section.....	15
• Deleted register 0x00 from the <i>Register Map</i> section.....	19
• Changed register Address: 0x03.....	21
• Changed the <i>Single-Ended Source</i> section and 图 8-1.....	22
• Changed from: BSTA and BSTB to: BSTP and BSTN in the <i>Capacitor Selection</i> section.....	23
• Changed the <i>Differential Input Diagram</i> section and 图 8-6.....	25

Changes from Revision A (June 2016) to Revision B (September 2016) Page

- 将“特性”从“符合汽车级 (Q100) 标准”更改为：“通过 AEC-Q100 2 级鉴定” 1
- 将“特性”从“宽工作电压范围 (5V 至 18V)”更改为：“宽工作电压范围 (4.5V 至 18V)” 1
- 添加了特性：ISO9000：已通过 2002 TS16949 认证..... 1
- Changed the VDD MIN value From: 5 V to: 4.5 V in the [节 6.3](#) 5
- Changed From: operates from 5 V - 18 V To: operates from 4.5 V - 18 V in the [节 9](#) 26

Changes from Revision * (June 2016) to Revision A (June 2016) Page

- 发布为“量产数据” 1

5 Pin Configuration and Functions



图 5-1. TWP Package HTSSOP 16-Pin With Thermal Pad Top View

表 5-1. Pin Functions

PIN		TYPE	DESCRIPTION
NAME	NO.		
GND	1, 9, 16	P	Ground.
EN	2	I	Device enable pin.
REG	3	P	Internally generated gate voltage supply. Not to be used as a supply or connected to any component other than a 1 μ F X7R ceramic decoupling capacitor and the MODE resistor divider.
SDA	4	I	I ² C data.
SCL	5	I	I ² C clock.
IN+	6	I	Positive differential input.
IN-	7	I	Negative differential input.
STDBY	8	I	Standby pin.
BSTN	10	P	Boot strap for negative output, connect to 220 nF X5R, or better ceramic cap to OUT-.
OUT-	11	O	Negative output.
OUT+	12	O	Positive output.
BSTP	13	P	Boot strap for positive output, connect to 220 nF X5R, or better ceramic cap to OUT+.
INTZ	14	O	General fault reporting. Open drain. INTZ = High, normal operation INTZ = Low, fault condition
VDD	15	P	Power supply.
Thermal Pad		G	Connect to GND for best system performance. If not connected to GND, leave floating.

6 Specifications

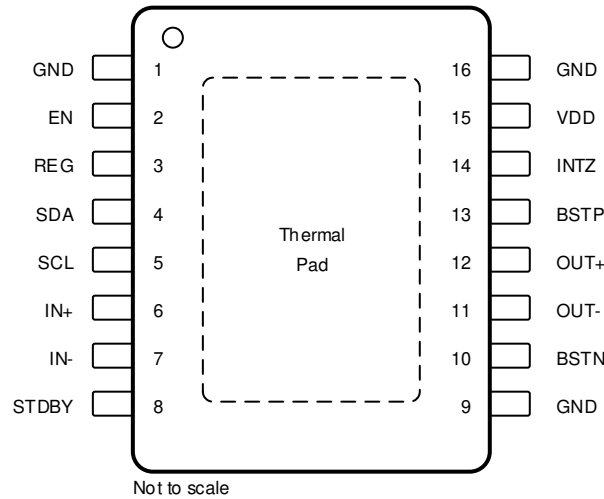
6.1 Absolute Maximum Ratings

over operating free-air temperature range (unless otherwise noted)⁽¹⁾

		MIN	MAX	UNIT
Supply voltage	VDD DC supply voltage range	- 0.3	30	V
	VDD pulsed supply voltage range. t < 400 ms exposure	- 1	40	
	VDD supply voltage ramp rate		15	V/ms
Input voltage, V _I	SCL, SDA, EN	- 0.3	5	V
	IN+, IN-, STDBY	- 0.3	6.5	
Current	DC current on VDD, GND, OUT+, OUT-	- 4	4	A
	Maximum current in all input pins	- 1	1	mA
	Maximum sink current for open-drain pins		7	
Operating free-air temperature, T _A		- 40	125	°C
Junction temperature, T _J		- 40	150	
Storage temperature range, T _{stg}		- 55	150	

- (1) Stresses beyond those listed under *Absolute Maximum Ratings* may cause permanent damage to the device. These are stress ratings only, which do not imply functional operation of the device at these or any other conditions beyond those indicated under *Recommended Operating Conditions*. Exposure to absolute-maximum-rated conditions for extended periods may affect device reliability.

6.2 ESD Ratings

		VALUE	UNIT
V _(ESD) Electrostatic discharge	Human body model (HBM), per AEC Q100-002 ⁽¹⁾ HBM ESD Classification Level H2	±3500	V
	Charged device model (CDM), per AEC Q100-011 CDM ESD Classification Level C4B	±1000	

- (1) AEC Q100-002 indicates that HBM stressing shall be in accordance with the ANSI/ESDA/JEDEC JS-001 specification.

6.3 Recommended Operating Conditions

over operating free-air temperature range (unless otherwise noted)

		MIN	NOM	MAX	UNIT
VDD	Supply voltage. VDD.	4.5		18	V
V _{IH}	High-level input voltage. SDA, SCL, STDBY, EN.	2.1			V
V _{IL}	Low-level input voltage. SDA, SCL, STDBY, EN			0.7	V
V _{OL}	Low-level output voltage			0.4	V
V _{OH}	High-level output voltage	2.4			V
I _{IH}	High-level input current. SDA, SCL, STDBY, EN			50	µA
R _L	Minimum load Impedance		1.5		Ω
C _B	Load capacitance for each bus line (SDA/SCL)			400	pF

6.4 Thermal Information

THERMAL METRIC ⁽¹⁾		DRV2510-Q1	UNIT
		PWP (HTSSOP)	
		{16} PINS	
R _{θJA}	Junction-to-ambient thermal resistance	39.4	°C/W
R _{θJC(top)}	Junction-to-case (top) thermal resistance	24.9	°C/W
R _{θJB}	Junction-to-board thermal resistance	20	°C/W
ψ _{JT}	Junction-to-top characterization parameter	0.6	°C/W

THERMAL METRIC ⁽¹⁾		DRV2510-Q1	
		PWP (HTSSOP)	
		{16} PINS	
ψ_{JB}	Junction-to-board characterization parameter	19.8	°C/W
$R_{\theta JC(bot)}$	Junction-to-case (bottom) thermal resistance	2	°C/W

(1) For more information about traditional and new thermal metrics, see the [Semiconductor and IC Package Thermal Metrics](#) application report.

6.5 Electrical Characteristics

$T_A = 25^\circ\text{C}$, $AVCC = VDD = 12\text{ V}$, $R_L = 5\ \Omega$ (unless otherwise noted)

PARAMETER		TEST CONDITIONS	MIN	TYP	MAX	UNIT
$ V_{OS} $	Output offset voltage (measured differentially)	$V_I = 0\text{ V}$, Gain = 20 dB	-25		25	mV
I_{VDD}	Quiescent supply current	No load or filter		16		mA
$I_{VDD(SD)}$	Quiescent supply current in shutdown mode	No load or filter		5	20	μA
$I_{VDD(STD BY)}$	Quiescent supply current in standby mode	No load or filter		7		mA
$r_{DS(on)}$	Drain-source on-state resistance, measured pin to pin	$T_J = 25^\circ\text{C}$		180		$\text{m}\Omega$
G	Gain	$P_{(o)} = 1\text{ W}$	19	20	21	dB
			25	26	27	
			31	32	33	dB
			35	36	37	
V_{REG}	Regulator voltage		6.4	6.9	7.4	V
V_O	Output voltage (measured differentially)			20		V
PSRR	Power supply ripple rejection	$VDD = 12\text{ V} + 1\text{ V}_{rms}$ at 1 kHz		75		dB
V_{ICMIN}	Input common-mode min			0.3		V
V_{ICMAX}	Input common-mode max			4.4		
CMRR	Common-mode rejection ratio	$f = 1\text{ kHz}$, 100 mV _{rms} referenced to GND. Gain = 20 dB		63		dB
f_{OSC}	Oscillator frequency (with PWM duty cycle < 96%)			400		kHz
				500		
	Output resistance in shutdown			10		$\text{M}\Omega$
	Resistance to detect a short from OUT pin(s) to VDD or GND				200	Ω
	Open-circuit detection threshold		75	95	120	Ω
	Short-circuit detection threshold		0.9	1.2	1.5	Ω
	Power-on threshold			4.1		V
	Thermal trip point			150		°C
	Thermal hysteresis			15		°C
	Over-current trip point			3.5		A
	Over-voltage trip point			21		V
	Over-voltage hysteresis			0.6		V
	Under-voltage trip point			4		V
	Under-voltage hysteresis			0.25		V
INTZ Report						
	INTZ pin output voltage for logic-level high (open-drain logic output)	External 47-k Ω pullup resistor to 3.3 V		2.4		V

$T_A = 25^\circ\text{C}$, $AVCC = VDD = 12\text{ V}$, $R_L = 5\ \Omega$ (unless otherwise noted)

PARAMETER	TEST CONDITIONS	MIN	TYP	MAX	UNIT
INTZ pin output voltage for logic-level low (open-drain logic output)	External 47-k Ω pullup resistor to 3.3 V			0.5	V

6.6 Timing Requirements

$T_A = 25\text{ }^\circ\text{C}$, $V_{DD} = 3.6\text{ V}$ (unless otherwise noted)

		MIN	NOM	MAX	UNIT
$f_{(SCL)}$	Frequency at the SCL pin with no wait states			400	kHz
$t_{w(H)}$	Pulse duration, SCL high	0.6			μs
$t_{w(L)}$	Pulse duration, SCL low	1.3			μs
$t_{su(1)}$	Setup time, SDA to SCL	100			ns
$t_{h(1)}$	Hold time, SCL to SDA	300			ns
$t_{(BUF)}$	Bus free time between stop and start condition	1.3			μs
$t_{su(2)}$	Setup time, SCL to start condition	0.6			μs
$t_{h(2)}$	Hold time, start condition to SCL	0.6			μs
$t_{su(3)}$	Setup time, SCL to stop condition	0.6			μs



图 6-1. SCL and SDA Timing



图 6-2. Timing for Start and Stop Conditions

6.7 Switching Characteristics

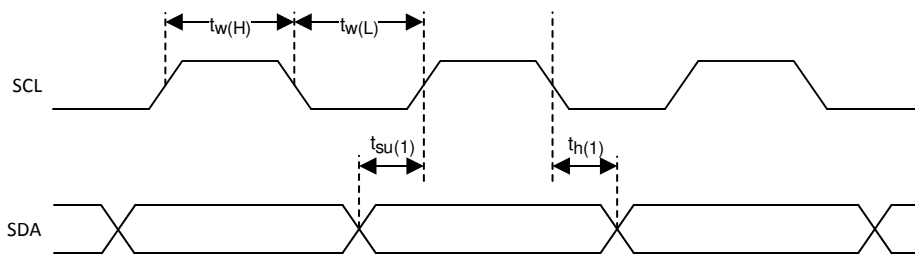
over operating free-air temperature range (unless otherwise noted)

PARAMETER	TEST CONDITIONS	MIN	TYP	MAX	UNIT	
t_{on-sd}	Turn-on time from shutdown to waveform EN = Low to High, STBY = Low		229			ms
t_{OFF-sd}	Turn-off time EN = High to Low		47		μs	
$t_{on-stbdy}$	Turn-on time from standby to waveform EN = High, STBY = High to Low		32		μs	

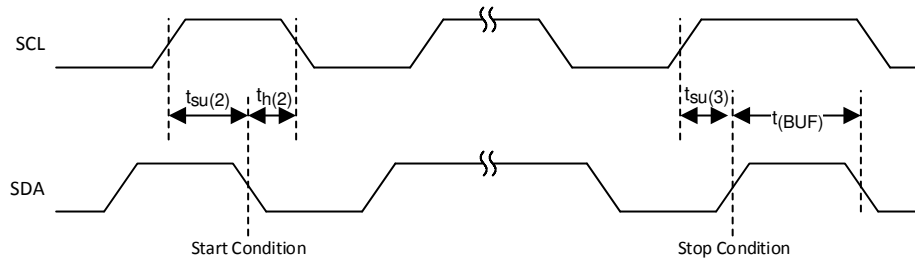
6.8 Typical Characteristics



图 6-3. Shutdown Current vs VDD Voltage



图 6-4. Standby Current vs VDD Voltage

7 Detailed Description

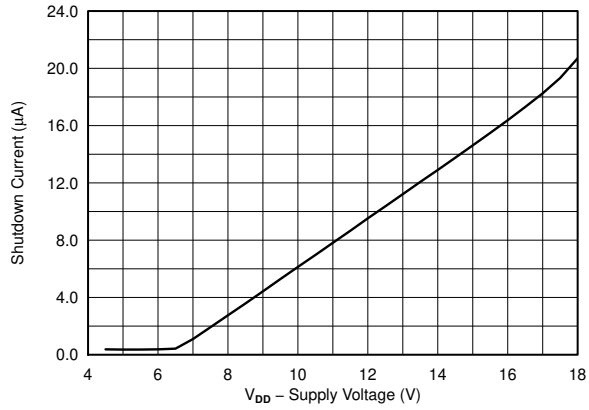
7.1 Overview

The DRV2510-Q1 device is a high current haptic driver specifically designed for inductive loads, such as solenoids and voice coils.

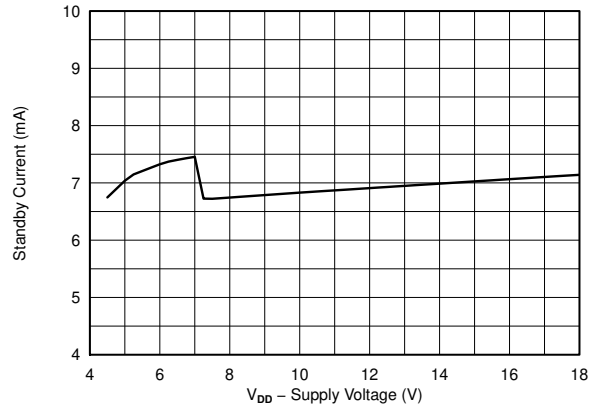
The output stage consists of a full H-bridge capable of delivering 3 A of peak current.

The design uses an ultra-efficient switching output technology developed by Texas Instruments, but with features added for the automotive industry. The DRV2510-Q1 device provides protection functions such as undervoltage lockout, over-current protection and over-temperature protection. This technology allows for reduced power consumption, reduced heat, and reduced peak currents in the electrical system.

The DRV2510-Q1 device is automotive qualified. The integrated load-dump protection reduces external voltage clamp cost and size, and the onboard load diagnostics report the status of the actuator through the digital interface.

7.2 Functional Block Diagram

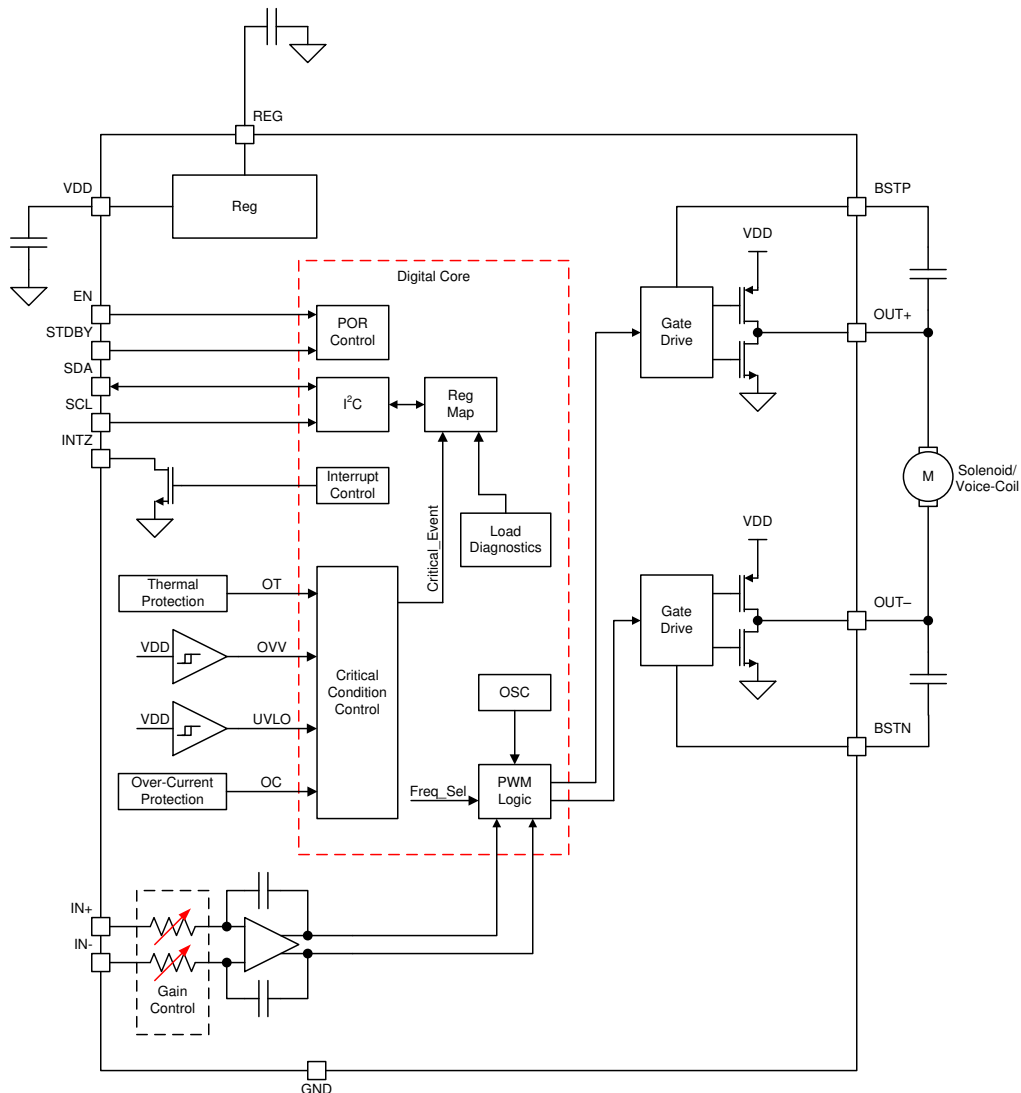

Copyright © 2016, Texas Instruments Incorporated

7.3 Feature Description

7.3.1 Analog Input and Configurable Pre-amplifier

The DRV2510-Q1 device features a differential input stage that cancels common-mode noise that appears on the inputs. The DRV2510-Q1 device also features four gain settings that are configurable via I²C. Please see the Programming Sections for register locations.

表 7-1. Gain Configuration Table

GAIN	INPUT IMPEDANCE
20 dB	60 k Ω
26 dB	30 k Ω
32 dB	15 k Ω
36 dB	9 k Ω

7.3.2 Pulse-Width Modulator (PWM)

The DRV2510-Q1 device features BD modulation scheme with high bandwidth, low noise, low distortion, and excellent stability.

The BD modulation scheme allows for smaller ripple currents through the load. Each output switches from 0 V to the supply voltage. With no input, the OUT+ and OUT- pins are in phase with each other so that there is little or no current in the load. For positive differential inputs, the duty cycle of OUT+ is greater than 50% and the duty cycle of OUT- is lower than 50% for a positive differential output voltage. The opposite is true for negative differential inputs. The voltage across the load sits at 0 V throughout most of the switching period, reducing the switching current, which reduces the I²R losses in the load.



图 7-1. BD Mode Modulation

7.3.3 Designed for low EMI

The DRV2510-Q1 device design has minimal parasitic inductances due to the short leads on the package. This dramatically reduces EMI that results from current passing from the die to the system PCB. The design incorporates circuitry that optimizes output transitions that causes EMI. Follow the recommended design requirements in the [§ 8.2.1.1](#) section.

7.3.4 Device Protection Systems

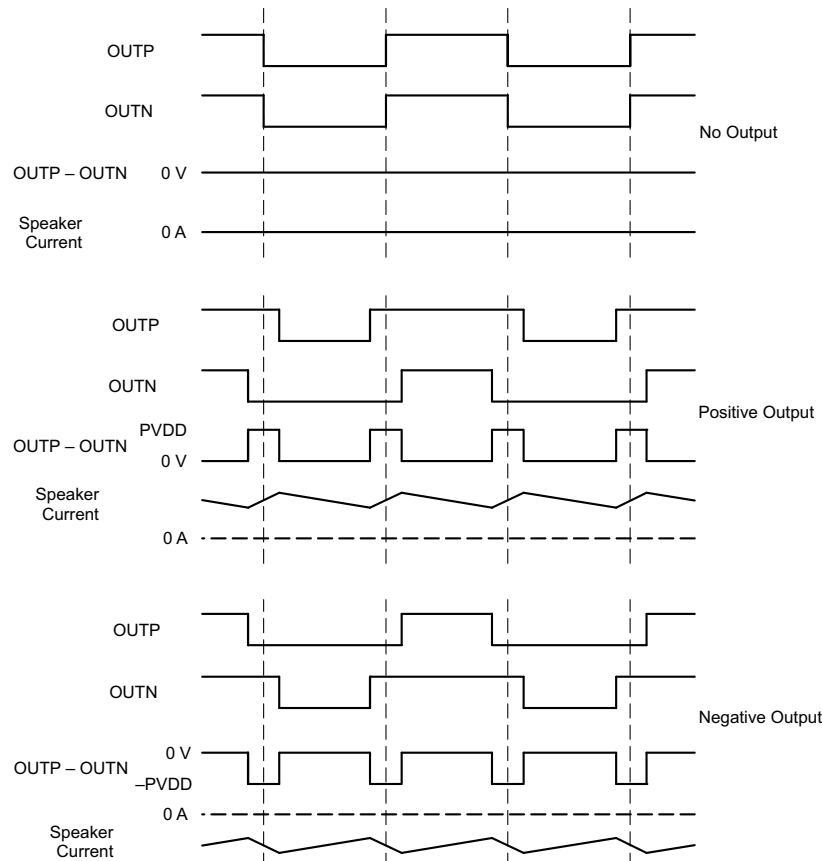
The DRV2510-Q1 device features a complete set of protection circuits carefully designed to protect the device against permanent failures due to shorts, over-temperature, over-voltage, and under-voltage scenarios. The INTZ pin signals if an error is detected.

Additionally, the DRV2510-Q1 device is not damaged by adjacent pin to pin shorts.

表 7-2. Fault Reporting Table

FAULT	TRIGGERING CONDITION	INTZ	ACTION
Over-current	Output short or short to VDD or GND	pulled low	output in high impedance. I ² updated.
Over-temperature	T _j > 150 °C	pulled low	output in high impedance. Recovery is automatic once the temperature returns to a safe level.
Under-voltage	VDD < 4 V	pulled low	output in high impedance. I ² reset.
Over-voltage	VDD > 21 V	pulled low	output in high impedance. I ² updated.

7.3.4.1 Diagnostics

The device incorporates load diagnostic circuitry designed for detecting and determining the status of output connections. The device supports the following diagnostics:

- Short to GND
- Short to VDD
- Short across load
- Open load

The device reports the presence of any of the short or open conditions to the system via I²C register read.

7.3.4.1.1 Load Diagnostics

The load diagnostic function runs on assertion of EN or when the device is in a fault state (dc detect, overcurrent, overvoltage, undervoltage, and overtemperature). During this test, the outputs are in a Hi-Z state. The device determines whether the output is a short to GND, short to VDD, open load, or shorted load. The load diagnostic biases the output, which therefore requires limiting the capacitance value for proper functioning. The load diagnostic test takes approximately 229 ms to run. Note that the *check* phase repeats up to five times if a fault is present or a large capacitor to GND is present on the output. On detection of an open load, the output still operates. On detection of any other fault condition, the output goes into a Hi-Z state, and the device checks the load continuously until removal of the fault condition. After detection of a normal output condition, the output starts. The load diagnostics run after every other overvoltage (OV) event. The load diagnostic for open load only has I²C reporting. All other faults have I²C and INTZ pin assertion.

The device performs load diagnostic tests as shown in [图 7-2](#).



图 7-2. Load Diagnostics Sequence of Events

图 7-3 illustrates how the diagnostics determine the load based on output conditions.

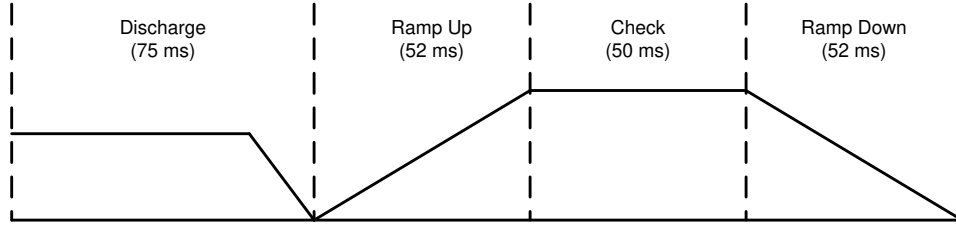

图 7-3. Load Diagnostic Reporting Thresholds

7.3.4.2 Faults During Load Diagnostics

If the device detects a fault (overtemperature, overvoltage, undervoltage) during the load diagnostics test, the device exits the load diagnostics, which may result in a small transient on the output.

7.3.4.3 Protection and Monitoring

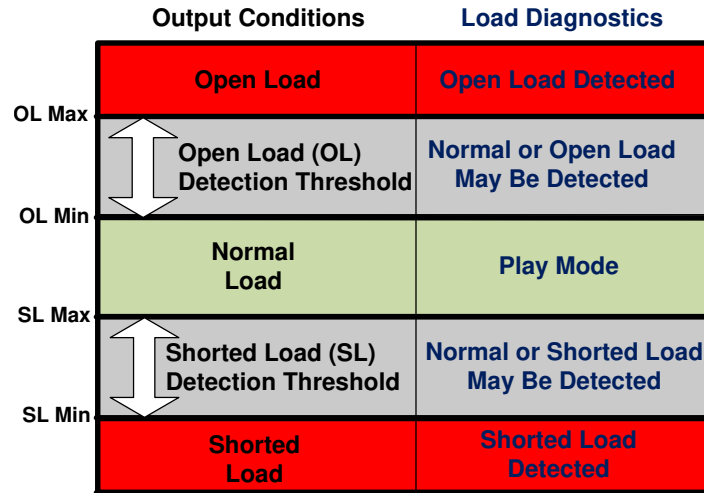
- **Overcurrent Shutdown (OCSO)**—The overcurrent shutdown forces the output into Hi-Z. The device asserts the INTZ pin and updates the I²C register.
- **DC Detect**—This circuit checks for a dc offset continuously during normal operation at the output of the amplifier. If a dc offset occurs, the device asserts the INTZ pin and updates the I²C register. Note that the dc detection threshold follows VDD changes.
- **Overtemperature Shutdown (OTSD)**—The device shuts down when the die junction temperature reaches the overtemperature threshold. The device asserts the INTZ pin and updates I²C register. Recovery is automatic when the temperature returns to a safe level.
- **Undervoltage (UV)**—The undervoltage (UV) protection detects low voltages on VDD. In the event of an undervoltage condition, the device asserts the INTZ pin and resets the I²C register.
- **Power-On Reset (POR)**—Power-on reset (POR) occurs when VDD drops below the POR threshold. A POR event causes the I²C bus to go into a high-impedance state. After recovery from the POR event, the device restarts automatically with default I²C register settings. The I²C is active as long as the device is not in POR.
- **Overvoltage (OV) and Load Dump**—OV protection detects high voltages on VDD. If VDD reaches the overvoltage threshold, the device asserts the INTZ pin and updates the I²C register. The device can withstand 40-V load-dump voltage spikes.
- **SpeakerGuard™**—This protection circuitry limits the output voltage to the value selected in I²C register 0x03. This value determines both the positive and negative limits. The user can use the SpeakerGuard feature to improve battery life or protect the actuator from exceeding its excursion limits.
- **Adjacent-Pin Shorts**—The device design is such that shorts between adjacent pins do not cause damage.

7.4 Device Functional Modes

The DRV2510-Q1 device has multiple power states to optimize power consumption.

7.4.1 Operation in Shutdown Mode

The EN pin of the DRV2510-Q1 device puts the device in a shutdown mode. When EN is de-asserted (logic low), all internal blocks of the device are off to achieve ultra low power. I²C is not operational in this mode and the output is in Hi-Z state.

7.4.2 Operation in Standby Mode

The STDBY pin of the DRV2510-Q1 device puts the device in a standby mode. When STDBY is asserted (logic high), some internal blocks of the device are off to achieve low power while preserving the ability to wake up quickly to achieve low latency waveform playback.

7.4.3 Operation in Active Mode

The DRV2510-Q1 device is in active mode when it has a valid supply, and it is not in either shutdown or standby modes. In this mode the DRV2510-Q1 device is fully on and reproducing at the output the input times the gain.

7.5 Programming

7.5.1 General I²C Operation

The I²C bus employs two signals, SDA (data) and SCL (clock), to communicate between integrated circuits in a system. The bus transfers data serially, one bit at a time. The 8-bit address and data bytes are transferred with the most-significant bit (MSB) first. In addition, each byte transferred on the bus is acknowledged by the receiving device with an acknowledge bit. Each transfer operation begins with the master device driving a start condition on the bus and ends with the master device driving a stop condition on the bus. The bus uses transitions on the data pin (SDA) while the clock is at logic high to indicate start and stop conditions. A high-to-low transition on the SDA signal indicates a start, and a low-to-high transition indicates a stop. Normal data-bit transitions must occur within the low time of the clock period. 图 7-4 shows a typical sequence. The master device generates the 7-bit slave address and the read-write (R/W) bit to start communication with a slave device. The master device then waits for an acknowledge condition. The slave device holds the SDA signal low during the acknowledge clock period to indicate acknowledgment. When the acknowledgment occurs, the master transmits the next byte of the sequence. Each device is addressed by a unique 7-bit slave address plus a R/W bit (1 byte). All compatible devices share the same signals through a bidirectional bus using a wired-AND connection.

The number of bytes that can be transmitted between start and stop conditions is not limited. When the last word transfers, the master generates a stop condition to release the bus. 图 7-4 shows a generic data-transfer sequence.

Use external pull-up resistors for the SDA and SCL signals to set the logic-high level for the bus. Pull-up resistors between 660 Ω and 4.7 k Ω are recommended. Do not allow the SDA and SCL voltages to exceed the DRV2510-Q1 supply voltage, V_{DD}.

备注

The DRV2510-Q1 slave address is 0x6C (7-bit), or 1101100 in binary.



图 7-4. Typical I²C Sequence

The DRV2510-Q1 device operates as an I²C-slave 1.8-V logic thresholds, but can operate up to the V_{DD} voltage. The device address is 0x5A (7-bit), or 1011010 in binary which is equivalent to 0xB4 (8-bit) for writing and 0xB5 (8-bit) for reading.

7.5.2 Single-Byte and Multiple-Byte Transfers

The serial control interface supports both single-byte and multiple-byte R/W operations for all registers.

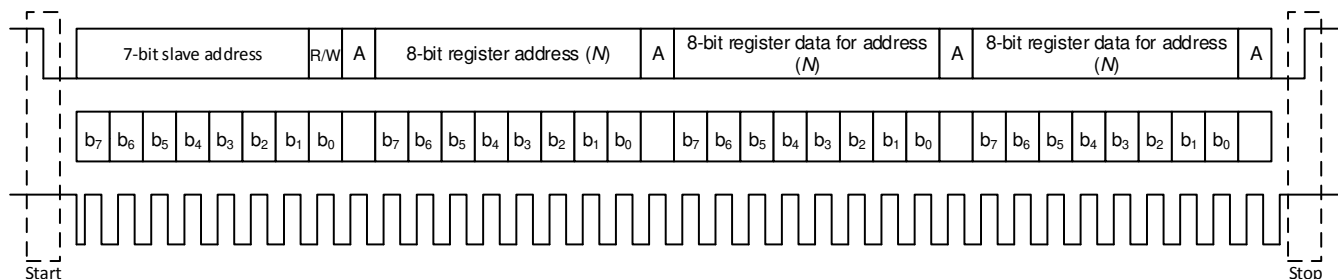
During multiple-byte read operations, the DRV2510-Q1 device responds with data one byte at a time and begins at the signed register. The device responds as long as the master device continues to respond with acknowledges.

The DRV2510-Q1 supports sequential I²C addressing. For write transactions, a sequential I²C write transaction has taken place if a register is issued followed by data for that register as well as the remaining registers that follow. For I²C sequential-write transactions, the register issued then serves as the starting point and the amount of data transmitted subsequently before a stop or start is transmitted determines how many registers are written.

7.5.3 Single-Byte Write

As shown in 图 7-5, a single-byte data-write transfer begins with the master device transmitting a start condition followed by the I²C device address and the read-write bit. The read-write bit determines the direction of the data transfer. For a write-data transfer, the read-write bit must be set to 0. After receiving the correct I²C device address and the read-write bit, the DRV2510-Q1 responds with an acknowledge bit. Next, the master transmits the register byte corresponding to the DRV2510-Q1 internal-memory address that is accessed. After receiving the register byte, the device responds again with an acknowledge bit. Finally, the master device transmits a stop condition to complete the single-byte data-write transfer.



图 7-5. Single-Byte Write Transfer

7.5.4 Multiple-Byte Write and Incremental Multiple-Byte Write

A multiple-byte data write transfer is identical to a single-byte data write transfer except that multiple data bytes are transmitted by the master device to the DRV2510-Q1 device as shown in 图 7-6. After receiving each data byte, the DRV2510-Q1 device responds with an acknowledge bit.

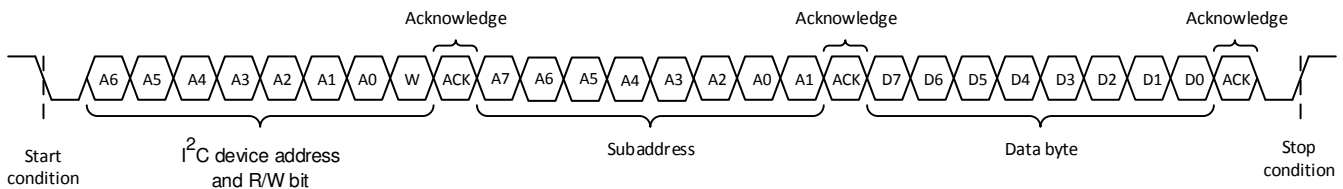

图 7-6. Multiple-Byte Write Transfer

7.5.5 Single-Byte Read

图 7-7 shows that a single-byte data-read transfer begins with the master device transmitting a start condition followed by the I²C device address and the read-write bit. For the data-read transfer, both a write followed by a read actually occur. Initially, a write occurs to transfer the address byte of the internal memory address to be read. As a result, the read-write bit is set to 0.

After receiving the DRV2510-Q1 address and the read-write bit, the DRV2510-Q1 device responds with an acknowledge bit. The master then sends the internal memory address byte, after which the device issues an acknowledge bit. The master device transmits another start condition followed by the DRV2510-Q1 address and the read-write bit again. On this occasion, the read-write bit is set to 1, indicating a read transfer. Next, the DRV2510-Q1 device transmits the data byte from the memory address that is read. After receiving the data byte, the master device transmits a not-acknowledge followed by a stop condition to complete the single-byte data read transfer. See the note in the 节 7.5.1 section.

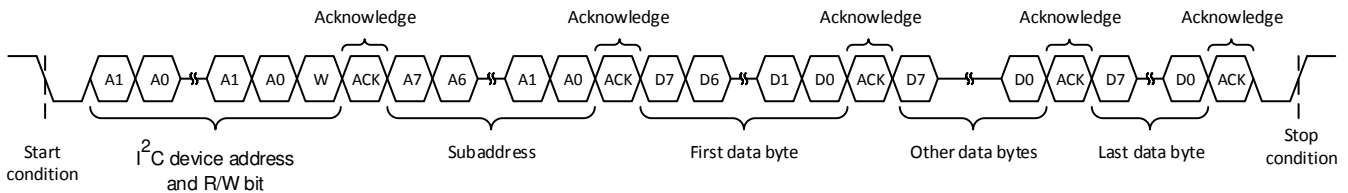

图 7-7. Single-Byte Read Transfer

7.5.6 Multiple-Byte Read

A multiple-byte data-read transfer is identical to a single-byte data-read transfer except that multiple data bytes are transmitted by the DRV2510-Q1 device to the master device as shown in 图 7-8. With the exception of the last data byte, the master device responds with an acknowledge bit after receiving each data byte.

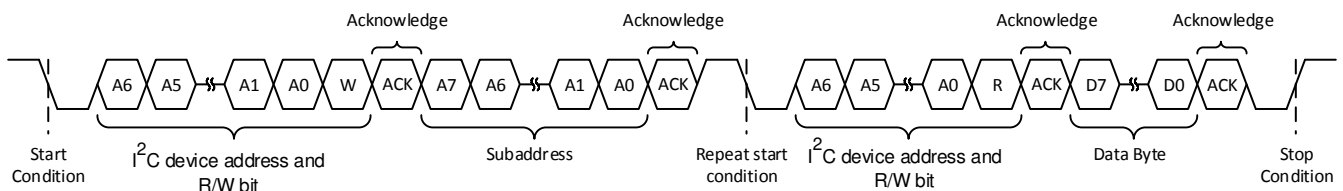

图 7-8. Multiple-Byte Read Transfer

7.6 Register Map

表 7-3. Register Map Overview

REG NO.	DEFAULT	BIT 7	BIT 6	BIT 5	BIT 4	BIT 3	BIT 2	BIT 1	BIT 0
0x01	0x00	OVER_TEMP	DC_OFFSET	OVER_VOLT	UNDER_VOLT	OVER_CURR	LOAD_DIAG	Reserved	
0x02	0x00	DEV_ACTIVE	STDBY	DIAG_ACTIVE	FAULT	LOAD_SHORT	LOAD_OPEN	LOAD_SHORT_G ND	LOAD_SHORT_ VDD
0x03	0x00	GAIN[1:0]		PEAK_PROTECTION[1:2]			Reserved		FREQ_SEL

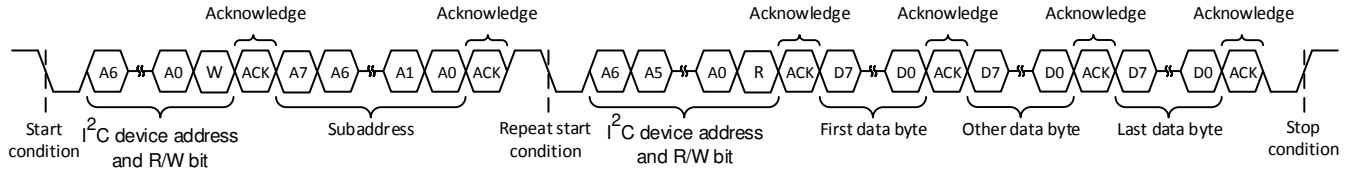
7.6.1 Address: 0x01

图 7-9. 0x01

7	6	5	4	3	2	1	0
OVER_TEMP[0]	DC_OFFSET[0]	OVER_VOLT[0]	UNDER_VOLT[0]	OVER_CURR[0]	LOAD_DIAG[0]	Reserved	
RO-0	RO-0	RO-0	RO-0	RO-0	RO-0		

表 7-4. Address: 0x01

BIT	FIELD	TYPE	DEFAULT	DESCRIPTION	
7	OVER_TEMP	RO	0	Shows the current status of the thermal protection	
				0	Temperature is below the over-temperature threshold.
				1	Temperature is above the over-temperature threshold.
6	DC_OFFSET	RO	0	Shows the status of DC offset protection	
				0	DC offset protection has not occurred.
				1	DC offset protection has occurred.
5	OVER_VOLT	RO	0	Shows the status of the over-voltage protection.	
				0	VDD voltage is below the over-voltage threshold.
				1	VDD voltage is above the over-voltage threshold.
4	UNDER_VOLT	RO	0	Shows the status of the under-voltage protection.	
				0	VDD voltage is above the under-voltage threshold.
				1	VDD voltage is below the under-voltage threshold.
3	OVER_CURR	RO	0	Shows the status of the over-current protection.	
				0	An over-current event has not occurred.
				1	Device shutdown due to over-current.
2	LOAD_DIAG	RO	0	Shows the status of the load diagnostics.	
				0	An open or short has not been detected.
				1	An open or short was detected.
1:0	Reserved				

7.6.2 Address: 0x02

图 7-10. 0x02

7	6	5	4	3	2	1	0
DEV_ACTIVE [0]	STDBY [0]	DIAG_ACTIVE [0]	FAULT [0]	LOAD_SHORT [0]	LOAD_OPEN [0]	LOAD_SHORT_GND [0]	LOAD_SHORT_VDD [0]
RO-0	RO-0	RO-0	RO-0	RO-0	RO-0	RO-0	RO-0

表 7-5. Address: 0x02

BIT	FIELD	TYPE	DEFAULT	DESCRIPTION	
7	DEV_ACTIVE	RO	0	Shows the device status (active or shutdown).	
				0	Device is shutdown.
				1	Device is active.
6	STDBY	RO	0	Shows the device standby status.	
				0	Device is not on standby.
				1	Device is on standby.
5	DIAG_ACTIVE	RO	0	Shows the status of the diagnostics engine.	
				0	Not performing load diagnostics.
				1	Performing load diagnostics.
4	FAULT	RO	0	Shows if a fault has occurred on the system. Either over-voltage, under-voltage, over-current, over-temperature.	
				0	No fault has occurred.
				1	A fault has occurred.
3	LOAD_SHORT	RO	0	Shows whether the output is shorted.	
				0	OUT+ is not shorted to OUT-.
				1	OUT+ is shorted to OUT-.
2	LOAD_OPEN	RO	0	Shows whether the output has a proper load connected.	
				0	A proper load is connected between OUT+ and OUT-.
				1	There is an open connection between OUT+ and OUT-.
1	LOAD_SHORT_GND	RO	0	Shows whether the output is shorted to GND.	
				0	Output is not shorted to GND.
				1	Either OUT+ or OUT- is shorted to GND.
0	LOAD_SHORT_VDD	RO	0	Shows whether the output is shorted to VDD.	
				0	Output is not shorted to VDD.
				1	Either OUT+ or OUT- is shorted to VDD.

7.6.3 Address: 0x03

图 7-11. 0x03

7	6	5	4	3	2	1	0
GAIN[1:0]		PEAK_PROTECTION[2:0]			Reserved		FREQ_SEL[0]
R/W-0		R/W-0			R/W-0		R/W-0

表 7-6. Address: 0x03

BIT	FIELD	TYPE	DEFAULT	DESCRIPTION	
7:6	GAIN[1:0]	R/W	01	Sets the gain.	
				0	20 dB.
				1	26 dB.
				2	32 dB.
				3	36 dB.
5:3	PEAK_PROTECTION[2:0]	R/W	111	Sets the peak output protection.	
				0	5V pk
				1	5.9 Vpk
				2	7 Vpk
				3	8.4 Vpk
				4	9.8 Vpk
				5	11.8 Vpk
				6	14 Vpk
7	Protection disabled				
2:1	Reserved		00	Always write default values	
0	FREQ_SEL	R/W	0	Sets the output frequency.	
				0	400 kHz.
				1	500 kHz.

8 Application and Implementation

备注

以下应用部分中的信息不属于 TI 器件规格的范围，TI 不担保其准确性和完整性。TI 的客户应负责确定器件是否适用于其应用。客户应验证并测试其设计，以确保系统功能。

8.1 Application Information

The DRV2510-Q1 device is a high-efficiency driver for inductive loads, such as solenoids and voice-coils. The typical use of the device is on haptic applications where short, strong waveforms are desired to create a haptic event that will be coming from the application processor.

8.2 Typical Applications

8.2.1 Single-Ended Source

To use the DRV2510-Q1 with a single-ended source, apply either a voltage divider to bias IN- to 3 V, or use a 0.1- μ F cap from IN- to GND to have the device self bias. Apply the single-ended signal to the IN+ pin through an AC coupling capacitor.



图 8-1. Typical Application Schematic

8.2.1.1 Design Requirements

For most applications the following component values found in [表 8-1](#) below can be used.

表 8-1. Component Requirements Table

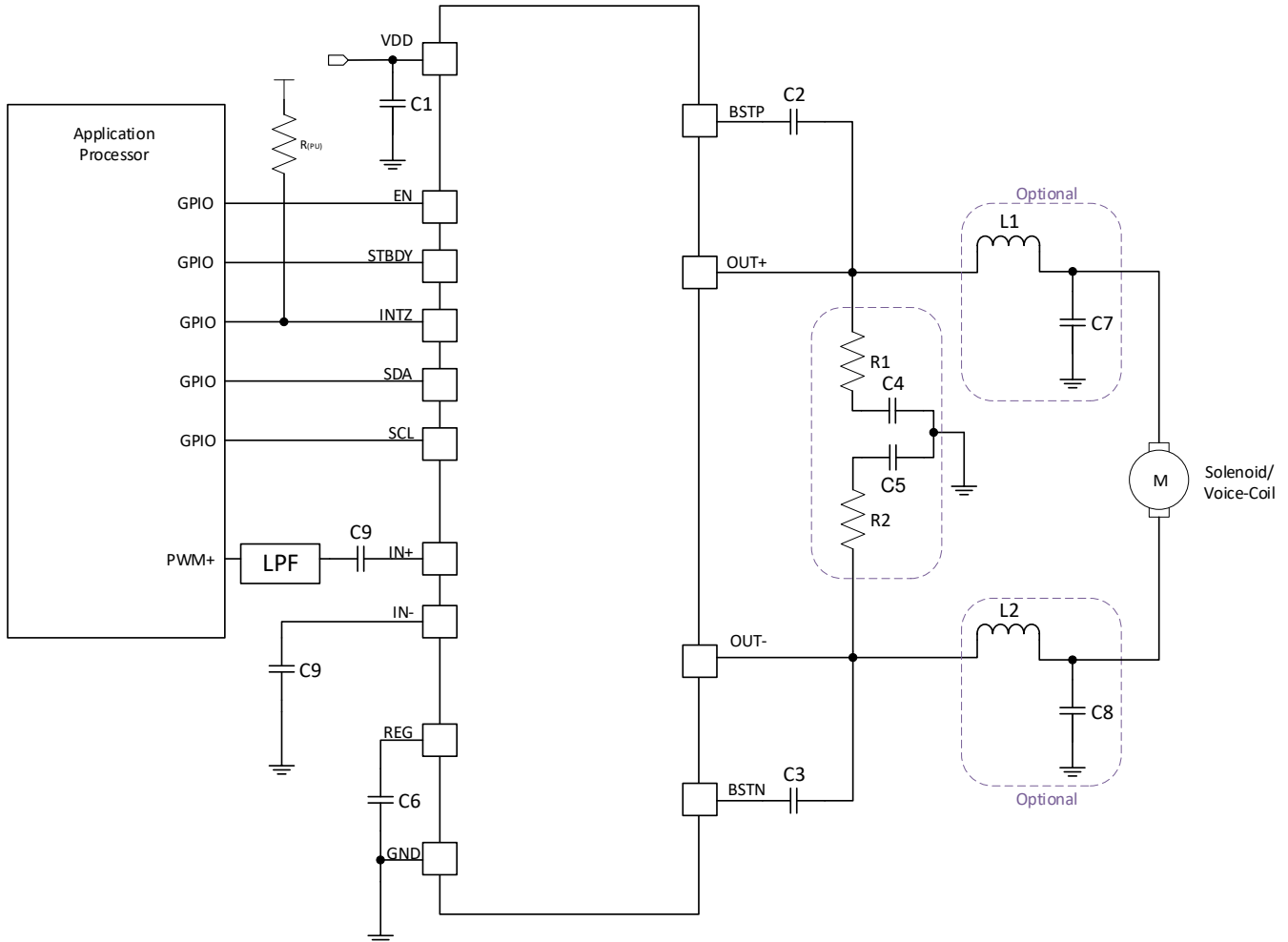
COMPONENT	DESCRIPTION	SPECIFICATION	TYPICAL VALUE
C1	Supply capacitor	Capacitance	22 μF, 10 μF, and 0.1 μF
C2/C3	Boost capacitor	Capacitance	0.22 μF
C4/C5	Output snubber capacitor	Capacitance	470 pF
C6	Regulator capacitor	Capacitance	1 μF
C9	Input decoupling capacitor	Capacitance	0.1 μF
R1/R2	Output snubber resistor	Resistance	3.3 Ω
R _(PU)	Pull-up resistor	Resistance	100 kΩ

8.2.1.2 Detailed Design Procedure

8.2.1.2.1 Optional Components

Note that in the diagrams, there are a few optional external components. These optional external components may be needed in the application to meet EMI/EMC standards and specifications by filters necessary frequency spectrums.

8.2.1.2.2 Capacitor Selection

A bulk bypass capacitor should be mounted between VBAT and GND. The capacitance needs to be >22 uF with a X5R or better rating on the power pins to GND. Also include two ceramic capacitors in the ranges of 220 pF to 1 uF and 100 nF to 1 uF. The bootstrap capacitors, BSTP and BSTN, should be 220-nF ceramic capacitors of quality X5R or better rated for at least the maximum rating of the pin.

8.2.1.2.3 Solenoid Selection

The DRV2510-Q1 solenoid driver can accommodate a variety of solenoids. Solenoids should have an equivalent resistance of 1.6 Ω or greater. Solenoids with lower resistances are prone to driving high currents. A maximum peak current of 3-A should not be exceeded.

8.2.1.2.4 Output Filter Considerations

The output filter is optional and is mainly for limiting peak currents. A second-order Butterworth low-pass filter with the cut-off frequency set to a few kilohertz should be sufficient. See [Equation 1](#), through [Equation 4](#), for example filter design.

$$H(s) = \frac{1}{s^2 + \sqrt{2}s + 1} \quad (1)$$

$$L_x = \frac{\sqrt{2} \times R_L}{2\omega_0} \quad (2)$$

$$2 \times C_F = \frac{\sqrt{2}}{2 \times \frac{R_L}{2} \times \omega_0} \quad (3)$$

$$\omega_0 = 2\pi \times f \quad (4)$$

8.2.1.3 Application Curves

These application curves were taken using an HA200 solenoid with a 100-g mass, and the acceleration was measured using the DRV-AAC16-EVM accelerometer. The following scales apply to the graphs:

- Output Differential Voltage scale is shown on the plots at 5-V/div
- Acceleration scale is 5.85-G/div
- Current scale is 2-A/div



图 8-2. Voltage and Acceleration vs Time (Input Square Wave)



图 8-3. Voltage and Acceleration vs Time (Square Wave)

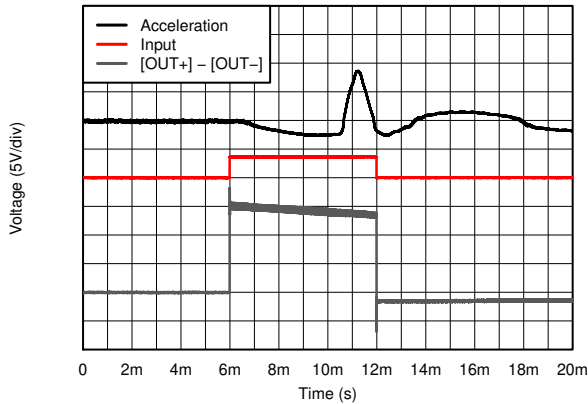

图 8-4. Voltage and Acceleration vs Time (Ramp Wave)

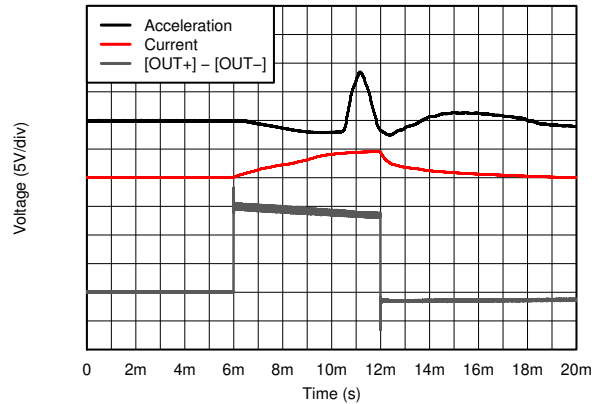

图 8-5. Voltage and Acceleration vs Time (1/2 Sine Wave)

8.2.1.4 Differential Input Diagram

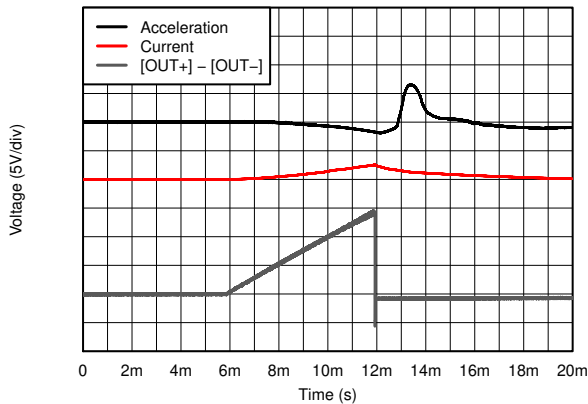
To use the DRV2510-Q1 with a differential input source, apply both inputs differentially through AC coupling capacitors from a control source (GPIO, DAC, etc...).

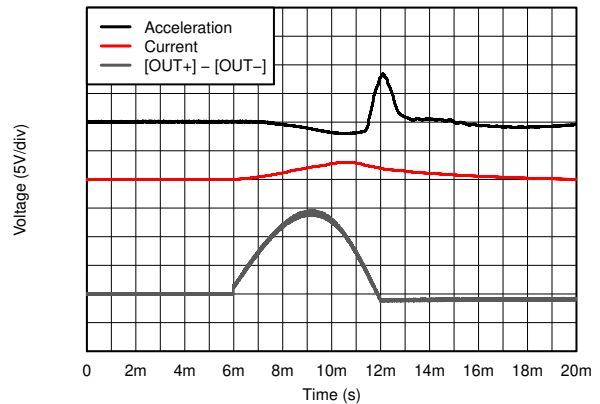

图 8-6. Typical Application Schematic

9 Power Supply Recommendations

The DRV2510-Q1 device operates from 4.5 V - 18 V and this supply should be able to handle high surge currents in order to meet the high current draws for haptics effects. Additionally the DRV2510-Q1 should have 22- μ F, 10- μ F and 0.1- μ F ceramic capacitors near the VDD pin for additional decoupling from trace routing.

10 Layout

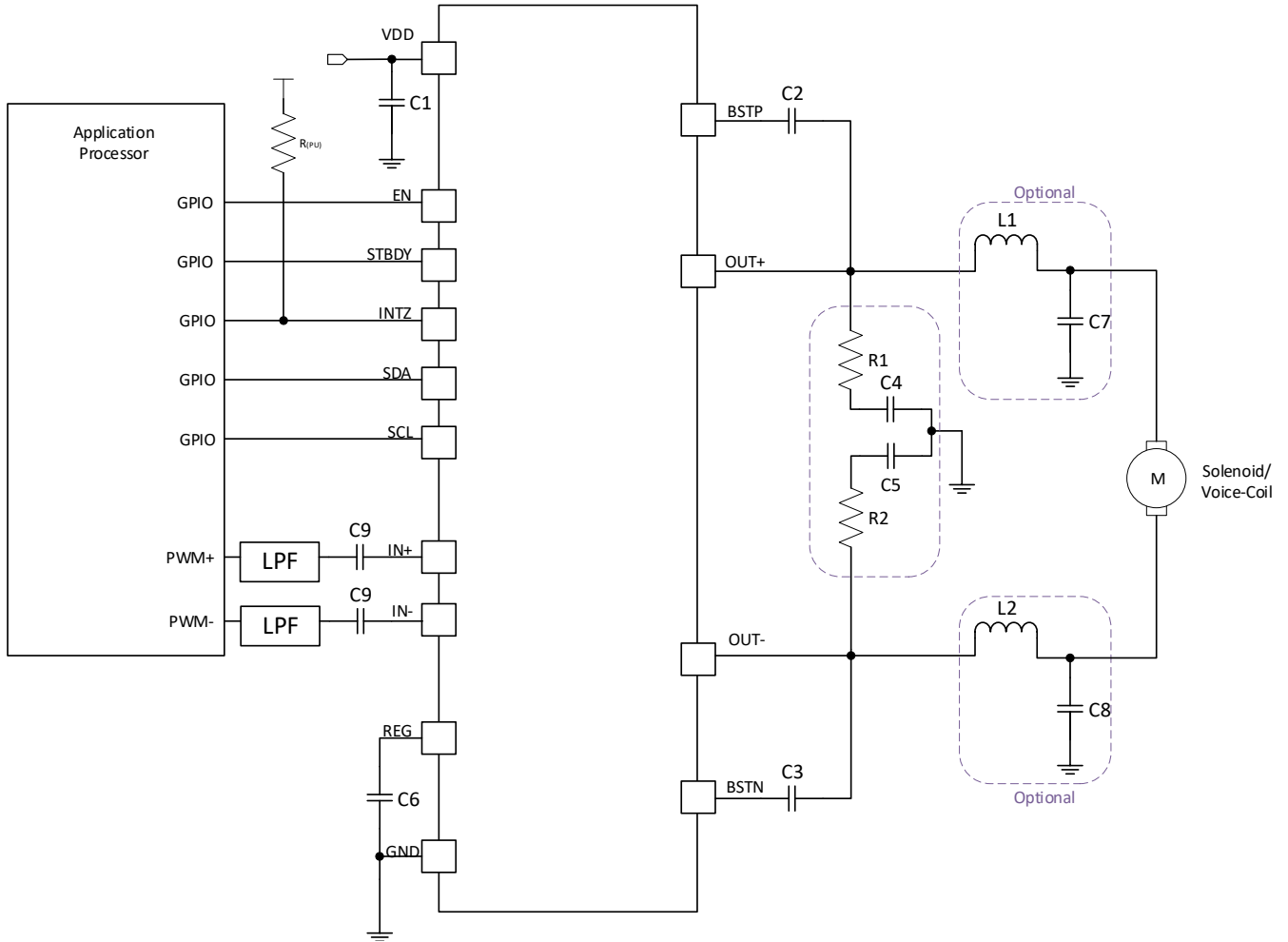
10.1 Layout Guidelines

The EVM layout optimizes for thermal dissipation and EMC performance. The DRV2510-Q1 device has a thermal pad down, and good thermal conduction and dissipation require adequate copper area. Layout also affects EMC performance. It is best practice to use the same/similar layout as shown below in the DRV2510Q1EVM.

10.2 Layout Example



图 10-1. DRV2510-Q1 EVM

11 Device and Documentation Support

11.1 Device Support

11.1.1 第三方产品免责声明

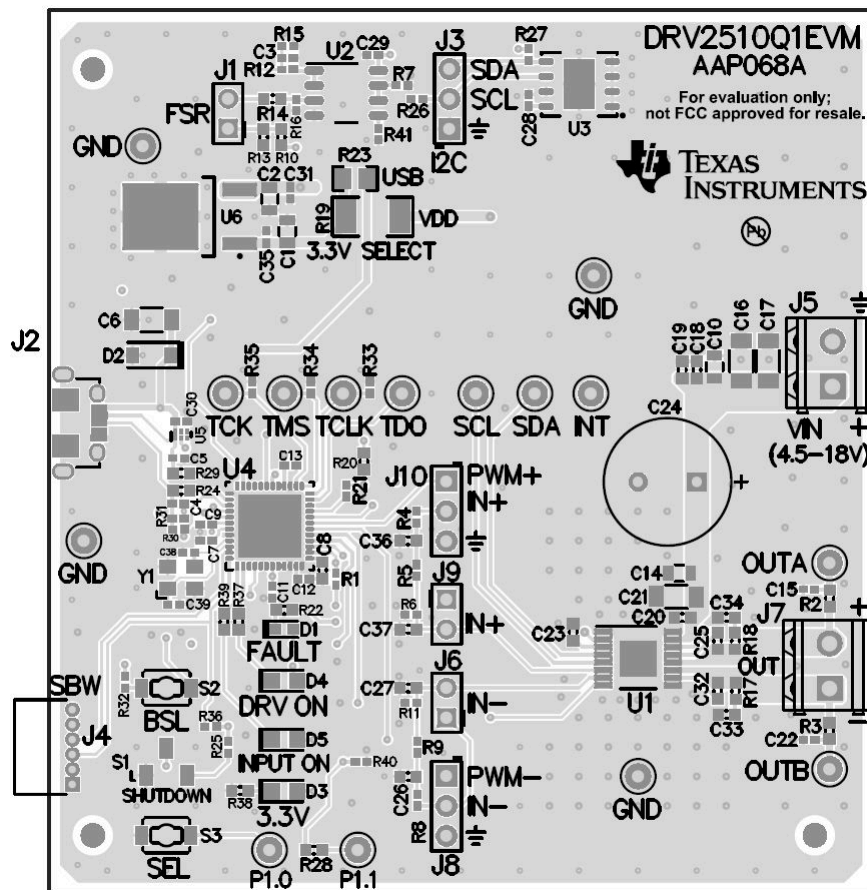
TI 发布的与第三方产品或服务有关的信息，不能构成与此类产品或服务或保修的适用性有关的认可，不能构成此类产品或服务单独或与任何 TI 产品或服务一起的表示或认可。

11.2 接收文档更新通知

要接收文档更新通知，请导航至 ti.com 上的器件产品文件夹。点击 [订阅更新](#) 进行注册，即可每周接收产品信息更改摘要。有关更改的详细信息，请查看任何已修订文档中包含的修订历史记录。

11.3 支持资源

TI E2E™ [支持论坛](#) 是工程师的重要参考资料，可直接从专家获得快速、经过验证的解答和设计帮助。搜索现有解答或提出自己的问题可获得所需的快速设计帮助。

链接的内容由各个贡献者“按原样”提供。这些内容并不构成 TI 技术规范，并且不一定反映 TI 的观点；请参阅 TI 的 [《使用条款》](#)。

11.4 Trademarks

SpeakerGuard™ and TI E2E™ are trademarks of Texas Instruments.

所有商标均为其各自所有者的财产。

11.5 静电放电警告



静电放电 (ESD) 会损坏这个集成电路。德州仪器 (TI) 建议通过适当的预防措施处理所有集成电路。如果不遵守正确的处理和安装程序，可能会损坏集成电路。

ESD 的损坏小至导致微小的性能降级，大至整个器件故障。精密的集成电路可能更容易受到损坏，这是因为非常细微的参数更改都可能会导致器件与其发布的规格不相符。

11.6 术语表

[TI 术语表](#) 本术语表列出并解释了术语、首字母缩略词和定义。

12 Mechanical, Packaging, and Orderable Information

The following pages include mechanical, packaging, and orderable information. This information is the most current data available for the designated devices. This data is subject to change without notice and revision of this document. For browser-based versions of this data sheet, refer to the left-hand navigation.

PACKAGING INFORMATION

Orderable part number	Status (1)	Material type (2)	Package Pins	Package qty Carrier	RoHS (3)	Lead finish/ Ball material (4)	MSL rating/ Peak reflow (5)	Op temp (°C)	Part marking (6)
DRV2510QPWPRQ1	Active	Production	HTSSOP (PWP) 16	2000 LARGE T&R	Yes	NIPDAU	Level-3-260C-168 HR	-40 to 125	DRV2510
DRV2510QPWPRQ1.B	Active	Production	HTSSOP (PWP) 16	2000 LARGE T&R	Yes	NIPDAU	Level-3-260C-168 HR	-40 to 125	DRV2510

(1) **Status:** For more details on status, see our [product life cycle](#).

(2) **Material type:** When designated, preproduction parts are prototypes/experimental devices, and are not yet approved or released for full production. Testing and final process, including without limitation quality assurance, reliability performance testing, and/or process qualification, may not yet be complete, and this item is subject to further changes or possible discontinuation. If available for ordering, purchases will be subject to an additional waiver at checkout, and are intended for early internal evaluation purposes only. These items are sold without warranties of any kind.

(3) **RoHS values:** Yes, No, RoHS Exempt. See the [TI RoHS Statement](#) for additional information and value definition.

(4) **Lead finish/Ball material:** Parts may have multiple material finish options. Finish options are separated by a vertical ruled line. Lead finish/Ball material values may wrap to two lines if the finish value exceeds the maximum column width.

(5) **MSL rating/Peak reflow:** The moisture sensitivity level ratings and peak solder (reflow) temperatures. In the event that a part has multiple moisture sensitivity ratings, only the lowest level per JEDEC standards is shown. Refer to the shipping label for the actual reflow temperature that will be used to mount the part to the printed circuit board.

(6) **Part marking:** There may be an additional marking, which relates to the logo, the lot trace code information, or the environmental category of the part.

Multiple part markings will be inside parentheses. Only one part marking contained in parentheses and separated by a "~" will appear on a part. If a line is indented then it is a continuation of the previous line and the two combined represent the entire part marking for that device.

Important Information and Disclaimer:The information provided on this page represents TI's knowledge and belief as of the date that it is provided. TI bases its knowledge and belief on information provided by third parties, and makes no representation or warranty as to the accuracy of such information. Efforts are underway to better integrate information from third parties. TI has taken and continues to take reasonable steps to provide representative and accurate information but may not have conducted destructive testing or chemical analysis on incoming materials and chemicals. TI and TI suppliers consider certain information to be proprietary, and thus CAS numbers and other limited information may not be available for release.

In no event shall TI's liability arising out of such information exceed the total purchase price of the TI part(s) at issue in this document sold by TI to Customer on an annual basis.

TAPE AND REEL INFORMATION

QUADRANT ASSIGNMENTS FOR PIN 1 ORIENTATION IN TAPE



*All dimensions are nominal

Device	Package Type	Package Drawing	Pins	SPQ	Reel Diameter (mm)	Reel Width W1 (mm)	A0 (mm)	B0 (mm)	K0 (mm)	P1 (mm)	W (mm)	Pin1 Quadrant
DRV2510QPWRQ1	HTSSOP	PWP	16	2000	330.0	12.4	6.9	5.6	1.6	8.0	12.0	Q1
DRV2510QPWRQ1	HTSSOP	PWP	16	2000	330.0	12.4	6.9	5.6	1.6	8.0	12.0	Q1

TAPE AND REEL BOX DIMENSIONS

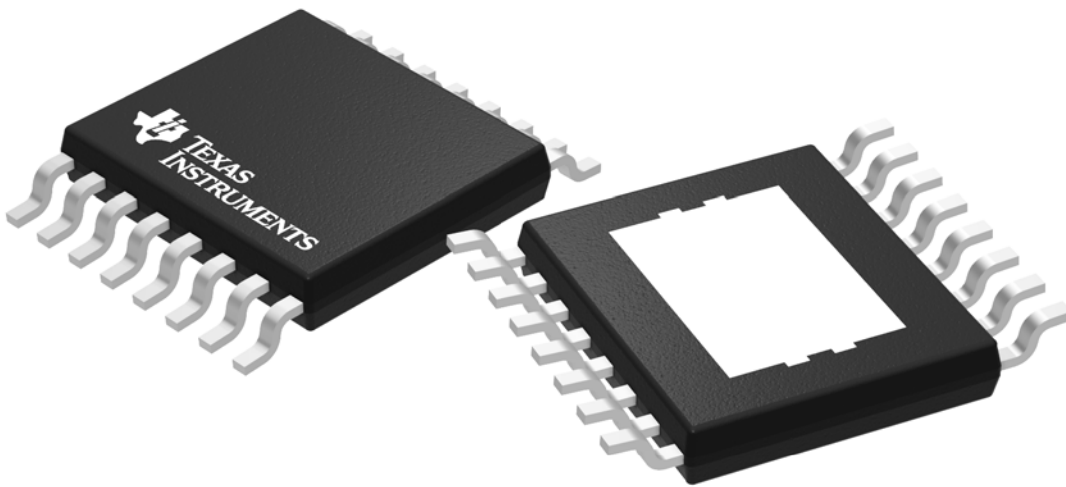

*All dimensions are nominal

Device	Package Type	Package Drawing	Pins	SPQ	Length (mm)	Width (mm)	Height (mm)
DRV2510QPWPRQ1	HTSSOP	PWP	16	2000	350.0	350.0	43.0
DRV2510QPWPRQ1	HTSSOP	PWP	16	2000	353.0	353.0	32.0

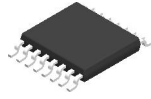

Images above are just a representation of the package family, actual package may vary.
Refer to the product data sheet for package details.

PWP0016B



PACKAGE OUTLINE

PowerPAD™ TSSOP - 1.2 mm max height

PLASTIC SMALL OUTLINE

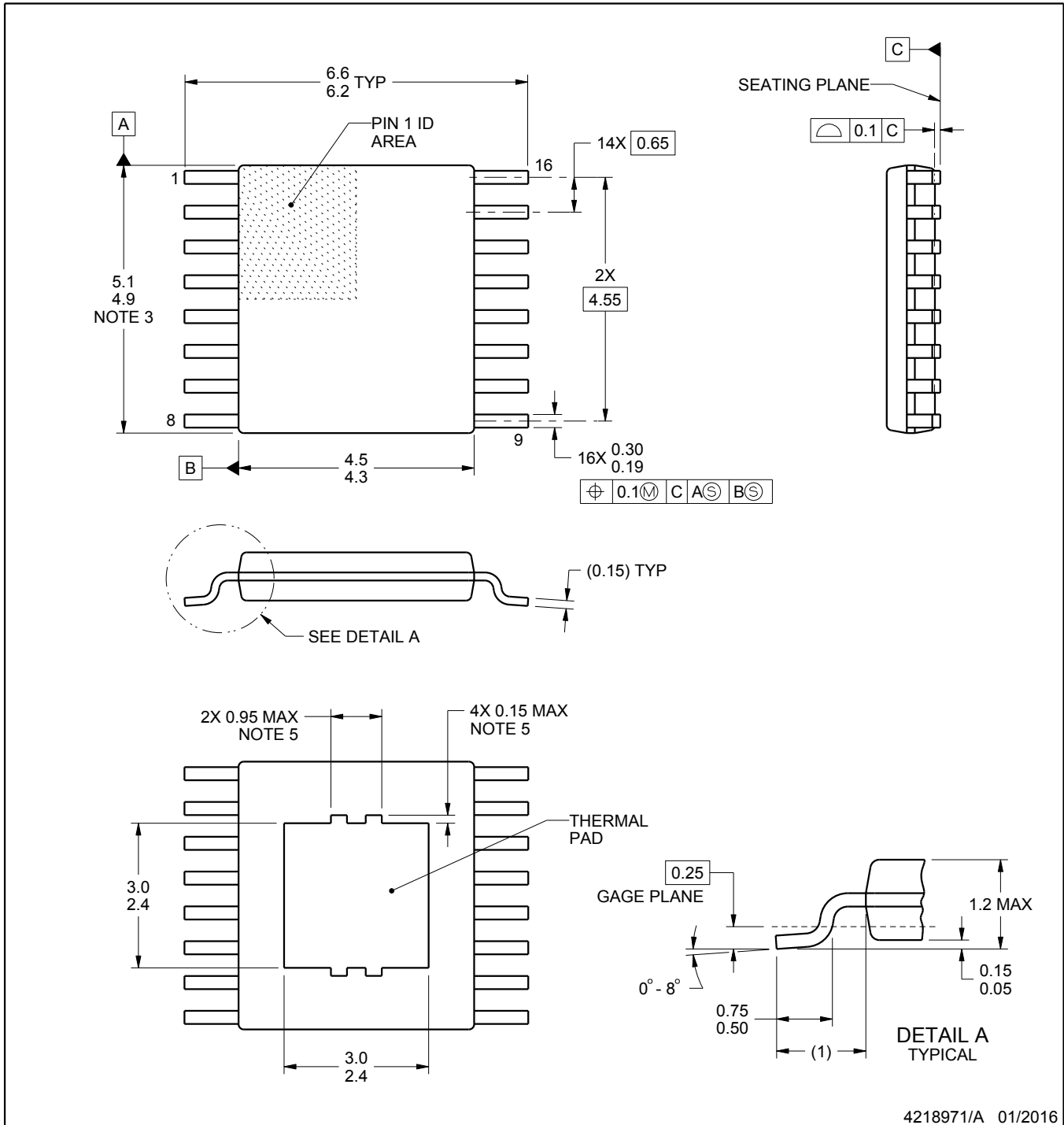

NOTES:

PowerPAD is a trademark of Texas Instruments.

1. All linear dimensions are in millimeters. Any dimensions in parenthesis are for reference only. Dimensioning and tolerancing per ASME Y14.5M.
2. This drawing is subject to change without notice.
3. This dimension does not include mold flash, protrusions, or gate burrs. Mold flash, protrusions, or gate burrs shall not exceed 0.15 mm per side.
4. Reference JEDEC registration MO-153.
5. Features may not be present.

EXAMPLE BOARD LAYOUT

PWP0016B

PowerPAD™ TSSOP - 1.2 mm max height

PLASTIC SMALL OUTLINE

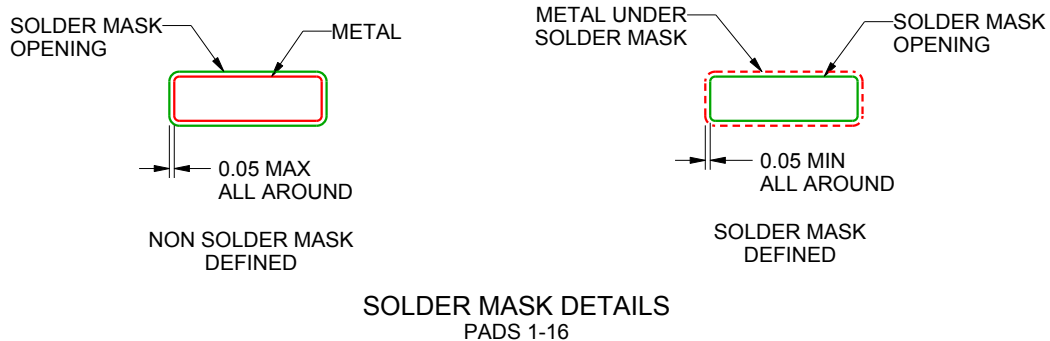
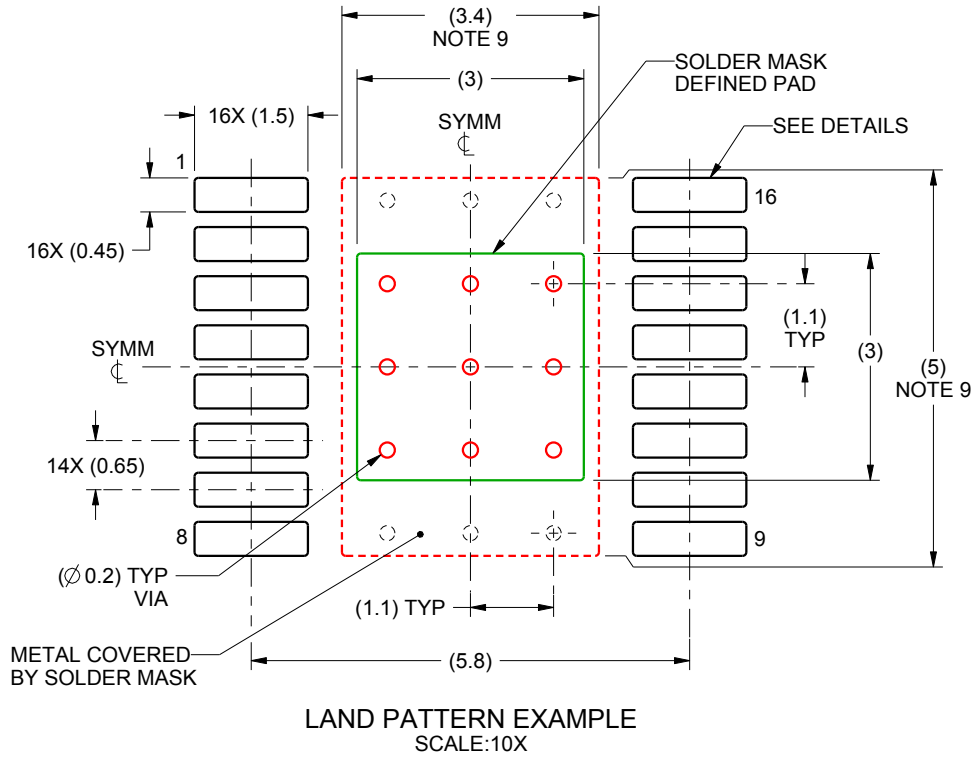

4218971/A 01/2016

NOTES: (continued)

6. Publication IPC-7351 may have alternate designs.
7. Solder mask tolerances between and around signal pads can vary based on board fabrication site.
8. This package is designed to be soldered to a thermal pad on the board. For more information, see Texas Instruments literature numbers SLMA002 (www.ti.com/lit/slma002) and SLMA004 (www.ti.com/lit/slma004).
9. Size of metal pad may vary due to creepage requirement.

EXAMPLE STENCIL DESIGN

PWP0016B

PowerPAD™ TSSOP - 1.2 mm max height

PLASTIC SMALL OUTLINE

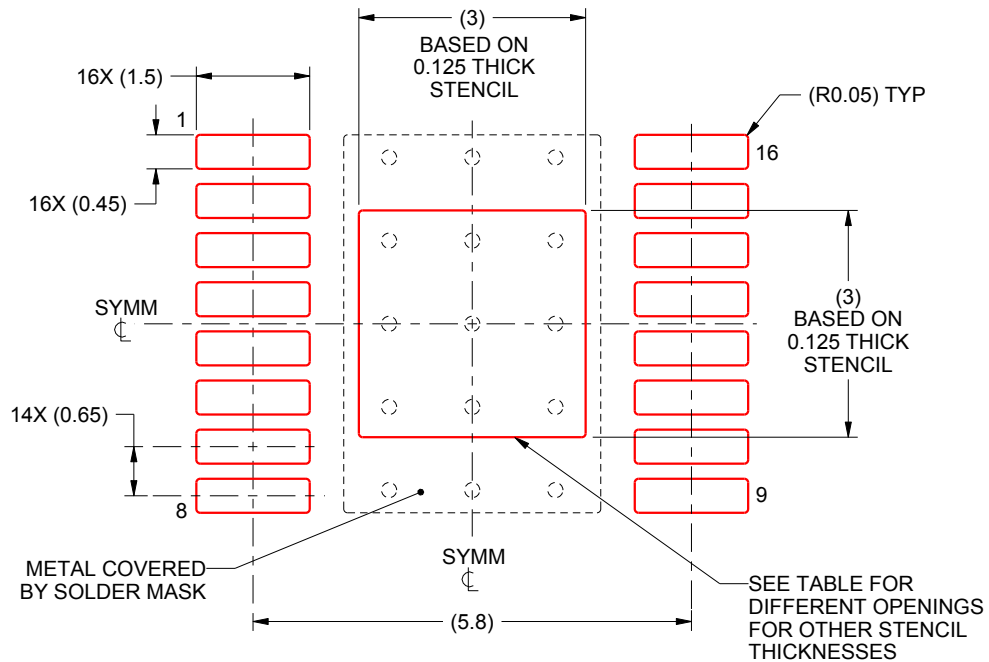

SOLDER PASTE EXAMPLE
 EXPOSED PAD
 100% PRINTED SOLDER COVERAGE BY AREA
 SCALE:10X

STENCIL THICKNESS	SOLDER STENCIL OPENING
0.1	3.35 X 3.35
0.125	3 X 3 (SHOWN)
0.15	2.74 X 2.74
0.175	2.54 X 2.54

4218971/A 01/2016

NOTES: (continued)

10. Laser cutting apertures with trapezoidal walls and rounded corners may offer better paste release. IPC-7525 may have alternate design recommendations.
11. Board assembly site may have different recommendations for stencil design.

重要通知和免责声明

TI“按原样”提供技术和可靠性数据（包括数据表）、设计资源（包括参考设计）、应用或其他设计建议、网络工具、安全信息和其他资源，不保证没有瑕疵且不做任何明示或暗示的担保，包括但不限于对适销性、与某特定用途的适用性或不侵犯任何第三方知识产权的暗示担保。

这些资源可供使用 TI 产品进行设计的熟练开发人员使用。您将自行承担以下全部责任：(1) 针对您的应用选择合适的 TI 产品，(2) 设计、验证并测试您的应用，(3) 确保您的应用满足相应标准以及任何其他安全、安保法规或其他要求。

这些资源如有变更，恕不另行通知。TI 授权您仅可将这些资源用于研发本资源所述的 TI 产品的相关应用。严禁以其他方式对这些资源进行复制或展示。您无权使用任何其他 TI 知识产权或任何第三方知识产权。对于因您对这些资源的使用而对 TI 及其代表造成的任何索赔、损害、成本、损失和债务，您将全额赔偿，TI 对此概不负责。

TI 提供的产品受 [TI 销售条款](#)、[TI 通用质量指南](#) 或 [ti.com](#) 上其他适用条款或 TI 产品随附的其他适用条款的约束。TI 提供这些资源并不会扩展或以其他方式更改 TI 针对 TI 产品发布的适用的担保或担保免责声明。除非德州仪器 (TI) 明确将某产品指定为定制产品或客户特定产品，否则其产品均为按确定价格收入目录的标准通用器件。

TI 反对并拒绝您可能提出的任何其他或不同的条款。

版权所有 © 2026，德州仪器 (TI) 公司

最后更新日期：2025 年 10 月