

适用于 DLP5500 DMD 的 DLPC200 DLP 数字控制器

1 特性

- 用于确保 DLP5500 DMD 可靠运行
- 通过两个 24 位输入端口确保实时数据流 (RGB888)
 - 端口 1 支持 HDMI 输入
 - 端口 2 通过扩展卡支持输入
- 高速图形序列模式
 - 将图形数据直接下载到器件
 - 1 位二进制图形速率高达 5000Hz
 - 8 位灰度图形速率高达 700Hz
 - 输入与微镜 1 对 1 映射
 - 可编程的图形重新排序
- 可与摄像机和传感器轻松同步
 - 三个可配置输出触发器
 - 两个可配置输入触发器
- 多个配置接口
 - 通过 I²C 支持 EDID
 - USB 和 SPI 器件控制

2 应用

- 机器视觉
 - 3D 深度测量和捕捉
 - 机器人导引
 - 挤压产品表面缺陷检测
 - 拾取与放置
- 3D 打印机
- 医疗仪器
 - 3D 牙齿扫描仪
 - 血管成像
 - 显微镜
- 计算机直接制版打印机
- 3D 生物辨识
 - 指纹识别
 - 面部识别

3 说明

DLPC200 执行图像处理和控制以及 DMD 数据格式化以驱动 0.55 XGA DMD (DLP5500)。

该数字控制器为用户提供可靠的独立高速微镜控制，用于结构光、显示和其他空间光调制 (SLM) 应用。

DLPC200 使用固态照明 (SSI) 提供高达 5000Hz 二进制或 700Hz 8 位灰度的图形速率。

这款易于编程的器件使用户能够将芯片组与外部源（例如传感器、摄像头和处理器）进行连接和同步，从而支持高精度的 3D 机器视觉应用。多个配置接口为外部和嵌入式输入源提供了灵活性。装载和存储定制图形的便利性使得 DLPC200 成为先进光控制应用的理想选择。

器件信息(1)

器件型号	封装	封装尺寸 (标称值)
DLPC200	BGA (780)	29.00mm x 29.00mm

(1) 如需了解所有可用封装，请参阅数据表末尾的可订购产品附录。

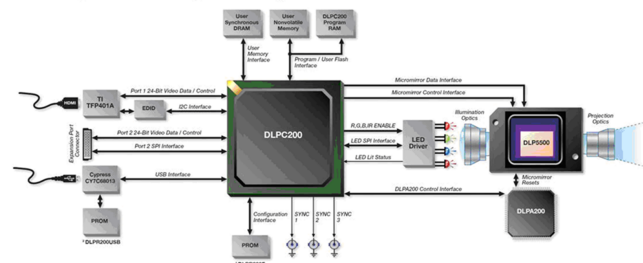

目录

1	特性	1	7	Detailed Description	35
2	应用	1	7.1	Overview	35
3	说明	1	7.2	Functional Block Diagram	35
4	修订历史记录	2	7.3	Feature Description	35
5	Pin Configuration and Functions	5	7.4	Device Functional Modes	36
6	Specifications	20	8	Application and Implementation	37
6.1	Absolute Maximum Ratings	20	8.1	Application Information	37
6.2	Handling Ratings	20	8.2	Typical Application	37
6.3	Recommended Operating Conditions	20	9	Power Supply Recommendations	45
6.4	Thermal Information	20	9.1	Power-Up Requirements	45
6.5	I/O Electrical Characteristics	21	9.2	Power-Down Requirements	45
6.6	Video Input Pixel Interface Timing Requirements	21	10	Layout	46
6.7	I ² C Interface Timing Requirements	23	10.1	Layout Guidelines	46
6.8	USB Read Interface Timing Requirements	25	10.2	Layout Example	46
6.9	USB Write Interface Timing Requirements	26	10.3	Thermal Considerations	47
6.10	SPI Slave Interface Timing Requirements	27	11	器件和文档支持	48
6.11	Parallel Flash Interface Timing Requirements	28	11.1	器件支持	48
6.12	Serial Flash Interface Timing Requirements	30	11.2	文档支持	48
6.13	Static RAM Interface Timing Requirements	31	11.3	接收文档更新通知	48
6.14	DMD Interface Timing Requirements	31	11.4	社区资源	48
6.15	DLPA200 Interface Timing Requirements	32	11.5	商标	49
6.16	DDR2 SDR Memory Interface Timing Requirements	33	11.6	静电放电警告	49
6.17	Video Input Pixel Interface – Image Sync and Blanking Requirements	34	11.7	Glossary	49
			12	机械、封装和可订购信息	49

4 修订历史记录

注：之前版本的页码可能与当前版本有所不同。

Changes from Revision E (August 2014) to Revision F	Page
• Added "(does not tristate)" to pin function entry SLAVE_SPI_MISO	8
• Deleted the active low indicator in the SLAVE_SPI_ACK in SPI Slave Interface Timing Requirements	27
• Changed SPI Timing Figure to reflect that the SLAVE_SPI_MISO signal does not tristate	27
• Changed SPI Timing Figure to reflect that SLAVE_SPI_ACK is an active high signal	27
• Removed active low indicator from the SLAVE_SPI_ACK signal in SPI Slave Interface	40
• Added clarifying note on the operation of the SLAVE_SPI_MOSI signal in SPI Slave Interface	40

Changes from Revision D (March 2012) to Revision E	Page
• 添加了处理额定值表、特性说明部分、器件功能模式、应用和实施部分、电源建议部分、布局部分、器件和文档支持部分以及机械、封装和可订购信息部分	1
• Updated descriptions in Pin Functions table	6
• Added Grounding scheme for Video Port 1 signals if not used	6
• Added Grounding scheme for video port 2 signals if not used	7
• Added Connection scheme for EDID and USB if not used	8
• Added Connection scheme for LED illumination Control if not used	15
• Added recommendation for 1-kΩ pullup to 3.3 V	15
• Changed from "recommend grounding" to "recommend 10-kΩ pulldown to DGND" for RSVD_S1, RSVD_S2, RSVD_S3, RSVD_X11, RSVD_S20, and RSVD_S21	17
• Changed description for RSVD_S0 from "do not connect" to "can be left open, recommend 10-kΩ pullup to 2.5 V"	17

• Changed pin description for RSVD_x15 and RSVD_X13 from "do not connect" to "do not leave open, required: 49.4-Ω pullup to 1.8 V"	17
• Changed pin description for RSVD_X14 and RSVD_X12 from "do not connect" to "do not leave open, required: 49.9-Ω pulldown to DGND"	17
• Changed from "do not connect" to "can be left open, recommend 10-kΩ pullup to 1.8 V" for RSVD_S4	17
• Changed pin description for RSVD_S18 and RSVD_S19 from "do not connect" to "can be left open, recommend 10-kΩ pullup to 2.5 V"	18
• Deleted Case Temperature thermal resistance	20
• Changed Micron MT47H32M16-25E replaces now obsolete MT47H32M16R	43
• Added Note about LED enabling after initialization is complete	45
• Added Heat Sink section	47

Changes from Revision C (February 2012) to Revision D
Page

• Changed the \overline{ADV} time line in Figure 6	28
--	----

Changes from Revision B (December 2010) to Revision C
Page

• Changed typo on pin number for PORT1_D10 Pin	6
• Changed typo on pin number for USB_CLK Pin	8
• Changed I/O type to B ₂ for USB interface data bus Pins	8
• Added pin number A15 to PINFUNCTIONS table	8
• Changed I/O type to B ₂ for Flash/SRAM data Pins	11
• Corrected the I/O type to O ₃ on $\overline{CFG_CS0}$ terminal pin	16
• Added pin number AB17, U7, U8, and AD15 to Pin Functions table	17
• Changed location of Absolute Maximum Ratings and Recommended Operating Conditions Tables in document	20
• Changed MIN and MAX T _J values in <i>Recommended Operating Conditions</i>	20
• Added V _{CC33} and V _{REF_B2-4} pins to <i>Recommended Operating Conditions</i>	20
• Changed Input Port Interface figure	22
• Changed SPI <i>Slave Interface Timing Requirements</i> table	27
• Added SPI Timing diagram	27
• Changed \overline{RST} signal timing in Parallel Flash Write Timing diagram	29
• Changed signal notations in <i>Serial Flash Interface Timing Requirements</i> table	30
• Changed signal notations in Flash Memory Interface Timing diagram	30
• Changed signal notations in DLPA200 I/F Timing diagram	32
• Changed Typical Application diagram	38
• Changed paragraph about read mode in <i>Parallel Flash Memory Interface</i>	41
• Deleted SRAM Interface Timing diagram and provided reference to the OEM data sheet	41
• Replaced "DAD" with "DLPA200"	42
• 已更改 文档中的器件标记的位置	48

Changes from Revision A (May 2010) to Revision B
Page

• Changed typo on pin number for MEM_D43 Pin	14
• Changed typo on pin number for MEM_D62 Pin	14
• Added part number used for EEPROM	40
• Changed part number for Winbond part	41
• Added new section for Power-Down Requirements	45

Changes from Original (April 2010) to Revision A	Page
• Added / changed pin names, updated descriptions in Pin Functions table	6
• Changed junction temperature and notated need for heat sink	20
• Deleted unused types, updated values in I/O Characteristics table	21
• Changed parameter names to match figure	34
• Added new section for Power-Up Requirements	45
• 已更改 在相关文档中将 TI 文献编号从 DLPS012 更改为 DLPZ004	48

5 Pin Configuration and Functions

**BGA
780 PINS**

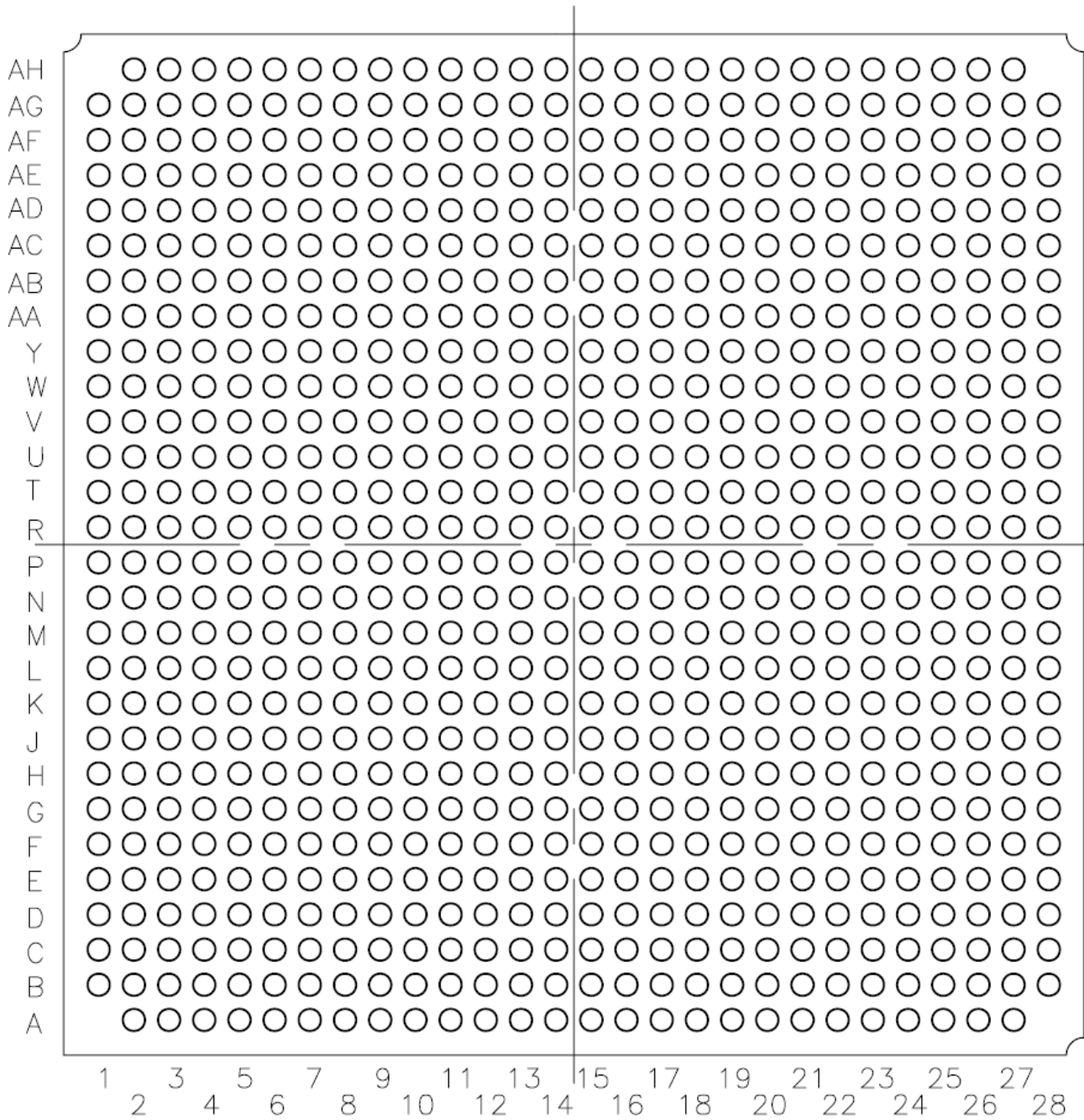

Pin Functions

PIN		I/O TYPE ⁽¹⁾	CLOCK SYSTEM	DESCRIPTION
NAME	NUMBER			
PORT 1 VIDEO DATA AND CONTROL⁽²⁾				
PORT1_CLK	J2	I ₃		Pixel clock (if not used, apply 10-kΩ pulldown to DGND)
PORT1_VSYNC	N3		PORT1_CLK	Vertical sync; weak pullup applied
PORT1_HSYNC	P1		PORT1_CLK	Horizontal sync; weak pullup applied
PORT1_IVALID	P2		PORT1_CLK	Data valid (if not used, apply 10-kΩ pulldown to DGND)
PORT1_D0	D2		PORT1_CLK	Pixel data – Blue 0 (if not used, apply 10-kΩ pulldown to DGND)
PORT1_D1	D3		PORT1_CLK	Pixel data – Blue 1 (if not used, apply 10-kΩ pulldown to DGND)
PORT1_D2	F5		PORT1_CLK	Pixel data – Blue 2 (if not used, apply 10-kΩ pulldown to DGND)
PORT1_D3	D1		PORT1_CLK	Pixel data – Blue 3 (if not used, apply 10-kΩ pulldown to DGND)
PORT1_D4	F3		PORT1_CLK	Pixel data – Blue 4 (if not used, apply 10-kΩ pulldown to DGND)
PORT1_D5	G4		PORT1_CLK	Pixel data – Blue 5 (if not used, apply 10-kΩ pulldown to DGND)
PORT1_D6	F1		PORT1_CLK	Pixel data – Blue 6 (if not used, apply 10-kΩ pulldown to DGND)
PORT1_D7	G3		PORT1_CLK	Pixel data – Blue 7 (if not used, apply 10-kΩ pulldown to DGND)
PORT1_D8	H5		PORT1_CLK	Pixel data – Green 0 (if not used, apply 10-kΩ pulldown to DGND)
PORT1_D9	H4		PORT1_CLK	Pixel data – Green 1 (if not used, apply 10-kΩ pulldown to DGND)
PORT1_D10	G2		PORT1_CLK	Pixel data – Green 2 (if not used, apply 10-kΩ pulldown to DGND)
PORT1_D11	J4		PORT1_CLK	Pixel data – Green 3 (if not used, apply 10-kΩ pulldown to DGND)
PORT1_D12	H3		PORT1_CLK	Pixel data – Green 4 (if not used, apply 10-kΩ pulldown to DGND)
PORT1_D13	J3		PORT1_CLK	Pixel data – Green 5 (if not used, apply 10-kΩ pulldown to DGND)
PORT1_D14	K3		PORT1_CLK	Pixel data – Green 6 (if not used, apply 10-kΩ pulldown to DGND)
PORT1_D15	L1		PORT1_CLK	Pixel data – Green 7 (if not used, apply 10-kΩ pulldown to DGND)
PORT1_D16	L3		PORT1_CLK	Pixel data – Red 0 (if not used, apply 10-kΩ pulldown to DGND)
PORT1_D17	L4		PORT1_CLK	Pixel data – Red 1 (if not used, apply 10-kΩ pulldown to DGND)
PORT1_D18	M4		PORT1_CLK	Pixel data – Red 2 (if not used, apply 10-kΩ pulldown to DGND)
PORT1_D19	K1	PORT1_CLK	Pixel data – Red 3 (if not used, apply 10-kΩ pulldown to DGND)	
PORT1_D20	M1	PORT1_CLK	Pixel data – Red 4 (if not used, apply 10-kΩ pulldown to DGND)	
PORT1_D21	K2	PORT1_CLK	Pixel data – Red 5 (if not used, apply 10-kΩ pulldown to DGND)	
PORT1_D22	M2	PORT1_CLK	Pixel data – Red 6 (if not used, apply 10-kΩ pulldown to DGND)	
PORT1_D23	M3	PORT1_CLK	Pixel data – Red 7 (if not used, apply 10-kΩ pulldown to DGND)	
PORT1_HPD	E15	B ₂		HDMI hotplug detect, (if not used, apply 10-kΩ pulldown to DGND)
PORT1_SYNCDET	J22			HDMI input sync detect, (if not used, apply 10-kΩ pulldown to DGND)

(1) See [I/O Electrical Characteristics](#) for more detail.

(2) 24-bit data is mapped according to RGB888 pixel format. See [Figure 13](#).

Pin Functions (continued)

PIN		I/O TYPE ⁽¹⁾	CLOCK SYSTEM	DESCRIPTION
NAME	NUMBER			
PORT 2 VIDEO DATA AND CONTROL⁽²⁾				
PORT2_CLK	Y2	I ₁		Pixel clock (if not used, apply 10-kΩ pulldown to DGND)
PORT2_VSYNC	AF2		PORT2_CLK	Vertical sync; weak pullup applied
PORT2_HSYNC	AB6		PORT2_CLK	Horizontal sync; weak pullup applied
PORT2_IVALID	W1		PORT2_CLK	Data valid (if not used, apply 10-kΩ pulldown to DGND)
PORT2_D0	Y1		PORT2_CLK	Pixel data – Blue 0 (if not used, apply 10-kΩ pulldown to DGND)
PORT2_D1	AE1		PORT2_CLK	Pixel data – Blue 1 (if not used, apply 10-kΩ pulldown to DGND)
PORT2_D2	U2		PORT2_CLK	Pixel data – Blue 2 (if not used, apply 10-kΩ pulldown to DGND)
PORT2_D3	AD12		PORT2_CLK	Pixel data – Blue 3 (if not used, apply 10-kΩ pulldown to DGND)
PORT2_D4	AB1		PORT2_CLK	Pixel data – Blue 4 (if not used, apply 10-kΩ pulldown to DGND)
PORT2_D5	V3		PORT2_CLK	Pixel data – Blue 5 (if not used, apply 10-kΩ pulldown to DGND)
PORT2_D6	U5		PORT2_CLK	Pixel data – Blue 6 (if not used, apply 10-kΩ pulldown to DGND)
PORT2_D7	T3		PORT2_CLK	Pixel data – Blue 7 (if not used, apply 10-kΩ pulldown to DGND)
PORT2_D8	AD1		PORT2_CLK	Pixel data – Green 0 (if not used, apply 10-kΩ pulldown to DGND)
PORT2_D9	AA3		PORT2_CLK	Pixel data – Green 1 (if not used, apply 10-kΩ pulldown to DGND)
PORT2_D10	R6		PORT2_CLK	Pixel data – Green 2 (if not used, apply 10-kΩ pulldown to DGND)
PORT2_D11	W3		PORT2_CLK	Pixel data – Green 3 (if not used, apply 10-kΩ pulldown to DGND)
PORT2_D12	AB5		PORT2_CLK	Pixel data – Green 4 (if not used, apply 10-kΩ pulldown to DGND)
PORT2_D13	AD3		PORT2_CLK	Pixel data – Green 5 (if not used, apply 10-kΩ pulldown to DGND)
PORT2_D14	AD5		PORT2_CLK	Pixel data – Green 6 (if not used, apply 10-kΩ pulldown to DGND)
PORT2_D15	AD4		PORT2_CLK	Pixel data – Green 7 (if not used, apply 10-kΩ pulldown to DGND)
PORT2_D16	AE5		PORT2_CLK	Pixel data – Red 0 (if not used, apply 10-kΩ pulldown to DGND)
PORT2_D17	AC11		PORT2_CLK	Pixel data – Red 1 (if not used, apply 10-kΩ pulldown to DGND)
PORT2_D18	AB8		PORT2_CLK	Pixel data – Red 2 (if not used, apply 10-kΩ pulldown to DGND)
PORT2_D19	AC7	PORT2_CLK	Pixel data – Red 3 (if not used, apply 10-kΩ pulldown to DGND)	
PORT2_D20	AG4	PORT2_CLK	Pixel data – Red 4 (if not used, apply 10-kΩ pulldown to DGND)	
PORT2_D21	AE4	PORT2_CLK	Pixel data – Red 5 (if not used, apply 10-kΩ pulldown to DGND)	
PORT2_D22	AF5	PORT2_CLK	Pixel data – Red 6 (if not used, apply 10-kΩ pulldown to DGND)	
PORT2_D23	AF3	PORT2_CLK	Pixel data – Red 7 (if not used, apply 10-kΩ pulldown to DGND)	
SYNC IN/SYNC OUT				
PORT1_Trig_in	F2	I ₃	PORT1_CLK	Alternate sync for port 1; treated as Vsync; weak pullup applied
PORT1_Sync_out	H6	O ₃	Async	Reserved for future use
PORT2_Trig_in	AB7	I ₁	PORT2_CLK	Alternate sync for port 2; treated as vsync; weak pullup applied
PORT2_Sync_out	Y3	O ₁	Async	Reserved for future use

Pin Functions (continued)

PIN		I/O TYPE ⁽¹⁾	CLOCK SYSTEM	DESCRIPTION
NAME	NUMBER			
CONTROL INTERFACES (I²C, USB, SPI)				
USB_CLK	B15	I ₃		USB clock input (48 MHz), feeds a PLL (if not used, apply 10-kΩ pulldown to DGND)
USB_CTRL0	B17	I ₃	USB_CLK	USB I/F FIFO programmable level (if not used, apply 10-kΩ pulldown to DGND)
USB_CTRL1	A26	I ₃	USB_CLK	USB I/F FIFO-full flag (if not used, apply 10-kΩ pulldown to DGND)
USB_CTRL2	D22	I ₃	USB_CLK	USB I/F FIFO-empty flag (if not used, apply 10-kΩ pulldown to DGND)
USB_CTRL3	C19	I ₃	USB_CLK	Reserved for future use (if not used, apply 10-kΩ pulldown to DGND)
USB_CTRL4	D16	I ₃	USB_CLK	Reserved for future use (if not used, apply 10-kΩ pulldown to DGND)
USB_CTRL5	G17	I ₃	USB_CLK	Reserved for future use (if not used, apply 10-kΩ pulldown to DGND)
USB_FD0	G16	B ₂	USB_CLK	USB interface data bus (if not used, apply 10-kΩ pulldown to DGND)
USB_FD1	C26			
USB_FD2	F17			
USB_FD3	C22			
USB_FD4	E18			
USB_FD5	B18			
USB_FD6	F18			
USB_FD7	E19			
USB_FD8	B23			
USB_FD9	D25			
USB_FD10	C21			
USB_FD11	D24			
USB_FD12	B19			
USB_FD13	E25			
USB_FD14	G18			
USB_FD15	C15			
USB_PA02	D23	O ₃	USB_CLK	USB I/F FIFO output enable for reads (if not used, apply 10-kΩ pullup to 3.3 V)
USB_PA04	G15	O ₃	USB_CLK	USB I/F FIFO address(0) (if not used, apply 10-kΩ pullup to 3.3 V)
USB_PA05	A22	O ₃	USB_CLK	USB I/F FIFO address(1) (if not used, apply 10-kΩ pullup to 3.3 V)
USB_PA06	A25	O ₃	USB_CLK	USB I/F FIFO packet end trigger
USB_RDY0	C16	O ₃	USB_CLK	USB I/F FIFO read enable (if not used, apply 10-kΩ pullup to 3.3 V)
USB_RDY1	C17	O ₃	USB_CLK	USB I/F FIFO write enable (if not used, apply 10-kΩ pullup to 3.3 V)
USB_RDY2	B26	O ₃	USB_CLK	Reserved for future use (if not used, apply 10-kΩ pullup to 3.3 V)
USB_RSVD_14	A15	I ₃	USB_CLK	Reserved for future use (if not used, apply 10-kΩ pulldown to DGND)
I2C_SCL	C25	B ₂		Master I ² C clock - 400 kHz. Requires external pullup
I2C_SDA	D18	B ₂	I2C_SCL	Master I ² C data - 400 kHz. Requires external pullup
EDID_I2C_SCL	F8	B ₂		HDMI EDID I ² C clock. 400 kHz. Requires external pullup (if EDID is not used, must be pulled up to 3.3 V through a 47-kΩ resistor)
EDID_I2C_SDA	D6	B ₂	EDID_I2C_SCL	HDMI EDID I ² C data. 400-kHz. Requires external pullup (if EDID is not used, must be pulled up to 3.3 V through a 47-kΩ resistor.)
SLAVE_SPI_CLK	B14	I ₃		Slave SPI clock
SLAVE_SPI_CS	C14	I ₃	SLAVE_SPI_CLK	Slave SPI chip select; weak pullup applied
SLAVE_SPI_MISO	D14	O ₃	SLAVE_SPI_CLK	Slave SPI data OUT (does not tristate)
SLAVE_SPI_MOSI	E14	I ₃	SLAVE_SPI_CLK	Slave SPI data IN; weak pullup applied
SLAVE_SPI_SOP	F21	I ₃	SLAVE_SPI_CLK	Reserved for future use
SLAVE_SPI_ACK	D20	O ₃	SLAVE_SPI_CLK	Slave SPI data busy

Pin Functions (continued)

PIN		I/O TYPE ⁽¹⁾	CLOCK SYSTEM	DESCRIPTION
NAME	NUMBER			
DMD INTERFACE				
DMD_DAT_AP1	AB27	O ₄	DMD_DCLK_AP, DMD_DCLK_AN	DMD data pins. LVDS pins for data bus A
DMD_DAT_AN1	AB28	O ₄		
DMD_DAT_AP3	Y25	O ₄		
DMD_DAT_AN3	Y26	O ₄		
DMD_DAT_AP5	W25	O ₄		
DMD_DAT_AN5	W26	O ₄		
DMD_DAT_AP7	W28	O ₄		
DMD_DAT_AN7	W27	O ₄		
DMD_DAT_AP9	V27	O ₄		
DMD_DAT_AN9	V28	O ₄		
DMD_DAT_AP11	V25	O ₄		
DMD_DAT_AN11	V26	O ₄		
DMD_DAT_AP13	V23	O ₄		
DMD_DAT_AN13	V24	O ₄		
DMD_DAT_AP15	T26	O ₄		
DMD_DAT_AN15	U27	O ₄		
DMD_DCLK_AP	T25	O ₄		DMD data clock. LVDS clock for data bus A
DMD_DCLK_AN	U28	O ₄		DMD data clock. LVDS clock for data bus A
DMD_SCTRL_AP	R25	O ₄	DMD_DCLK_AP, DMD_DCLK_AN	DMD data serial-control signal bus A (LVDS)
DMD_SCTRL_AN	R26	O		
DMD_DAT_BP1	AC24	O ₄	DMD_DCLK_BP, DMD_DCLK_BN	DMD data pins. LVDS pins for data bus B
DMD_DAT_BN1	AC25	O ₄		
DMD_DAT_BP3	AC26	O ₄		
DMD_DAT_BN3	AD26	O ₄		
DMD_DAT_BP5	AE27	O ₄		
DMD_DAT_BN5	AE28	O ₄		
DMD_DAT_BP7	AD27	O ₄		
DMD_DAT_BN7	AD28	O ₄		
DMD_DAT_BP9	Y23	O ₄		
DMD_DAT_BN9	Y24	O ₄		
DMD_DAT_BP11	AC27	O ₄		
DMD_DAT_BN11	AC28	O ₄		
DMD_DAT_BP13	AB25	O ₄		
DMD_DAT_BN13	AB26	O ₄		
DMD_DAT_BP15	AA25	O ₄		
DMD_DAT_BN15	AA26	O ₄		
DMD_DCLK_BP	U25	O ₄		DMD data clock. LVDS clock for data bus B
DMD_DCLK_BN	U26	O ₄		DMD data clock. LVDS clock for data bus B
DMD_SCTRL_BP	T21	O ₄	DMD_DCLK_AP, DMD_DCLK_AN	DMD data serial-control signal bus B (LVDS)
DMD_SCTRL_BN	T22	O ₄		
DMD_PWRDN	P26	O ₃	ASYNC	DMD power down (active-low)
RST_IRQ	M25	I ₃	ASYNC	DLPA200 interrupt (active-low)
RST_OE	M28	O ₃	ASYNC	DLPA200 output enable
RST_RST	H24	O ₃	ASYNC	DLPA200 reset
RST_STROBE	G28	O ₃		DLPA200 strobe

Pin Functions (continued)

PIN		I/O TYPE ⁽¹⁾	CLOCK SYSTEM	DESCRIPTION
NAME	NUMBER			
DMD INTERFACE (CONTINUED)				
RST_SEL0	G27	O ₃	RST_STROBE	DLPA200 voltage select
RST_SEL1	G26			
RST_MODE0	L24	O ₃	RST_STROBE	DLPA200 mode select
RST_MODE1	L23			
RST_A0	K25	O ₃	RST_STROBE	DLPA200 address
RST_A1	J26			
RST_A2	J25			
RST_A3	K26			
SCP_DMD_RST_DO	G25	O ₃	SCP_DMD_RST_CLK	SCP data out (write data)
SCP_DMD_RST_DI	H26	I ₃	SCP_DMD_RST_CLK	SCP data in (read data)
$\overline{\text{SCP_DMD_EN}}$	L25	O ₃	SCP_DMD_RST_CLK	DMD SCP chip select
$\overline{\text{SCP_RST_EN}}$	H23	O ₃	SCP_DMD_RST_CLK	DLPA200 SCP chip select
SCP_DMD_RST_CLK	H25	O ₃		DMD/DLPA200 SCP clock, 125 kHz
STATIC RAM INTERFACE				
$\overline{\text{FLASH_CE}}$	D12	O ₃	ASYNC	Flash chip enable
FLASH_SRAM_A0	D13	O ₃	$\overline{\text{FLASH_SRAM_WE}}$	Flash/SRAM address
FLASH_SRAM_A1	A11			
FLASH_SRAM_A2	C11			
FLASH_SRAM_A3	D11			
FLASH_SRAM_A4	A12			
FLASH_SRAM_A5	B12			
FLASH_SRAM_A6	D10			
FLASH_SRAM_A7	A10			
FLASH_SRAM_A8	B10			
FLASH_SRAM_A9	B8			
FLASH_SRAM_A10	C8			
FLASH_SRAM_A11	A7			
FLASH_SRAM_A12	B7			
FLASH_SRAM_A13	A4			
FLASH_SRAM_A14	D7			
FLASH_SRAM_A15	C6			
FLASH_SRAM_A16	D8			
FLASH_SRAM_A17	B6			
FLASH_SRAM_A18	C7			
FLASH_SRAM_A19	A8			
FLASH_SRAM_A20	C4			
FLASH_SRAM_A21	B3			
FLASH_SRAM_A22	A3			
FLASH_SRAM_A23	C5			
FLASH_SRAM_A24	D5			
FLASH_SRAM_A25	B4			
FLASH_SRAM_A26	D4			

Pin Functions (continued)

PIN		I/O TYPE ⁽¹⁾	CLOCK SYSTEM	DESCRIPTION
NAME	NUMBER			
STATIC RAM INTERFACE (CONTINUED)				
FLASH_SRAM_D0	E11	B ₂	$\overline{\text{FLASH_SRAM_WE}}$	Flash/SRAM data
FLASH_SRAM_D1	F10			
FLASH_SRAM_D2	E10			
FLASH_SRAM_D3	G9			
FLASH_SRAM_D4	E8			
FLASH_SRAM_D5	E7			
FLASH_SRAM_D6	E5			
FLASH_SRAM_D7	E4			
FLASH_SRAM_D8	F11			
FLASH_SRAM_D9	E12			
FLASH_SRAM_D10	F12			
FLASH_SRAM_D11	G12			
FLASH_SRAM_D12	G13			
FLASH_SRAM_D13	H13			
FLASH_SRAM_D14	F14			
FLASH_SRAM_D15	G14			
$\overline{\text{FLASH_SRAM_OE}}$	C10	O ₃		Flash output enable
FLASH_SRAM_RDY	C13	I ₃		Flash wait
$\overline{\text{FLASH_SRAM_RST}}$	C12	O ₃		Flash reset
$\overline{\text{FLASH_SRAM_WE}}$	A6	O ₃		Flash write enable
$\overline{\text{SRAM_CE}}$	B11	O ₃		SRAM chip enable
$\overline{\text{SRAM_LB}}$	D9	O ₃		SRAM lower byte enable
$\overline{\text{SRAM_UB}}$	C9	O ₃		SRAM upper byte enable
SDRAM INTERFACE				
MEM_CLK_P0	R2	O ₅		DDR2 memory, differential memory clock
MEM_CLK_N0	R1	O ₅		DDR2 memory, differential memory clock
MEM_CLK_P1	U3	O ₅		DDR2 memory, differential memory clock
MEM_CLK_N1	U4	O ₅		DDR2 memory, differential memory clock
MEM_CLK_P2	AC5	O ₅		DDR2 memory, differential memory clock
MEM_CLK_N2	AC4	O ₅		DDR2 memory, differential memory clock
MEM_CLK_P3	AE14	O ₅		DDR2 memory, differential memory clock
MEM_CLK_N3	AF14	O ₅		DDR2 memory, differential memory clock
MEM_CKE0	AF12	O ₅		
MEM_BA0	Y19	O ₅	MEM_CLK	
MEM_BA1	AD21	O ₅	MEM_CLK	
MEM_BA2	AE7	O ₅	MEM_CLK	

Pin Functions (continued)

PIN		I/O TYPE ⁽¹⁾	CLOCK SYSTEM	DESCRIPTION
NAME	NUMBER			
SDRAM INTERFACE (CONTINUED)				
MEM_A0	AD24	O ₅	MEM_CLK	DDR2 memory, multiplexed row and column address. The memory in the kit is 512 Mb in x16 mode, 8 Meg x 16 bits x 4 banks. Only A(12:0) and BA(1:0) are currently used. A(15:13) and BA(2) are reserved for future use (RFU).
MEM_A1	AF21			
MEM_A2	AG23			
MEM_A3	AE8			
MEM_A4	AG12			
MEM_A5	AF23			
MEM_A6	AC17			
MEM_A7	AA16			
MEM_A8	AE23			
MEM_A9	AE22			
MEM_A10	AE16			
MEM_A11	AD25			
MEM_A12	AF19			
MEM_A13	AH10			
MEM_A14	AA8			
MEM_A15	AD11			
MEM_CAS	AG19	O ₅	MEM_CLK	Column address strobe, active low
MEM_RAS	AE20	O ₅	MEM_CLK	Row address strobe, active low
MEM_CS0	AF13	O ₅	MEM_CLK	Chip select, active low
MEM_WE	AG25	O ₅	MEM_CLK	Write enable, active low
MEM_ODT	AH12	O ₅	MEM_CLK	
MEM_DM0	W2	O ₅	MEM_CLK	
MEM_DM1	AE2	O ₅	MEM_CLK	
MEM_DM2	AH6	O ₅	MEM_CLK	
MEM_DM3	AF7	O ₅	MEM_CLK	
MEM_DM4	AE13	O ₅	MEM_CLK	
MEM_DM5	AH18	O ₅	MEM_CLK	
MEM_DM6	AF24	O ₅	MEM_CLK	
MEM_DM7	AG26	O ₅	MEM_CLK	
MEM_DS0	AB2	B ₁	MEM_CLK_P0	
MEM_DS1	AE3	B ₁	MEM_CLK_N0	
MEM_DS2	AD7	B ₁	MEM_CLK_P1	
MEM_DS3	AE10	B ₁	MEM_CLK_N1	
MEM_DS4	AF11	B ₁	MEM_CLK_P2	
MEM_DS5	AF17	B ₁	MEM_CLK_N2	
MEM_DS6	AE18	B ₁	MEM_CLK_P3	
MEM_DS7	AF26	B ₁	MEM_CLK_N3	

Pin Functions (continued)

PIN		I/O TYPE ⁽¹⁾	CLOCK SYSTEM	DESCRIPTION
NAME	NUMBER			
SDRAM INTERFACE (CONTINUED)				
MEM_D0	R3	B ₁	MEM_DS0, MEM_DS1	
MEM_D1	R4	B ₁		
MEM_D2	T4	B ₁		
MEM_D3	R5	B ₁		
MEM_D4	U1	B ₁		
MEM_D5	V4	B ₁		
MEM_D6	V2	B ₁		
MEM_D7	V1	B ₁		
MEM_D8	U6	B ₁		
MEM_D9	Y4	B ₁		
MEM_D10	AC2	B ₁		
MEM_D11	AC1	B ₁		
MEM_D12	AC3	B ₁		
MEM_D13	AD2	B ₁		
MEM_D14	AB3	B ₁		
MEM_D15	AA4	B ₁		
MEM_D16	AE6	B ₁	MEM_DS2, MEM_DS3	
MEM_D17	AF4	B ₁		
MEM_D18	AG3	B ₁		
MEM_D19	AH3	B ₁		
MEM_D20	AF6	B ₁		
MEM_D21	AH4	B ₁		
MEM_D22	AD8	B ₁		
MEM_D23	AG6	B ₁		
MEM_D24	AB9	B ₁		
MEM_D25	AD10	B ₁		
MEM_D26	AG7	B ₁		
MEM_D27	AH7	B ₁		
MEM_D28	AC8	B ₁		
MEM_D29	AA10	B ₁		
MEM_D30	AG8	B ₁		
MEM_D31	AH8	B ₁		

Pin Functions (continued)

PIN		I/O TYPE ⁽¹⁾	CLOCK SYSTEM	DESCRIPTION
NAME	NUMBER			
SDRAM INTERFACE (CONTINUED)				
MEM_D32	AF8	B ₁	MEM_DS4, MEM_DS5	
MEM_D33	AE9	B ₁		
MEM_D34	AF10	B ₁		
MEM_D35	AG10	B ₁		
MEM_D36	AE12	B ₁		
MEM_D37	AE11	B ₁		
MEM_D38	AG11	B ₁		
MEM_D39	AH11	B ₁		
MEM_D40	AC15	B ₁		
MEM_D41	AF15	B ₁		
MEM_D42	AG17	B ₁		
MEM_D43	AH17	B ₁		
MEM_D44	AF16	B ₁		
MEM_D45	AB16	B ₁		
MEM_D46	AE17	B ₁		
MEM_D47	AG18	B ₁		
MEM_D48	AH19	B ₁		MEM_DS6, MEM_DS7
MEM_D49	AD17	B ₁		
MEM_D50	AG21	B ₁		
MEM_D51	AH21	B ₁		
MEM_D52	AG22	B ₁		
MEM_D53	AH22	B ₁		
MEM_D54	AH23	B ₁		
MEM_D55	AE19	B ₁		
MEM_D56	AF25	B ₁		
MEM_D57	AF20	B ₁		
MEM_D58	AD18	B ₁		
MEM_D59	AE21	B ₁		
MEM_D60	AE25	B ₁		
MEM_D61	AH25	B ₁		
MEM_D62	AF22	B ₁		
MEM_D63	AE24	B ₁		

Pin Functions (continued)

PIN		I/O TYPE ⁽¹⁾	CLOCK SYSTEM	DESCRIPTION
NAME	NUMBER			
LED DRIVER INTERFACE				
PWM0	C27	O ₃	Async	PWM signal used to control the LED current (if not used, apply 10-kΩ pull-down to DGND)
PWM1	D28	O ₃	Async	PWM signal used to control the LED current (if not used, apply 10-kΩ pull-down to DGND)
PWM2	D27	O ₃	Async	PWM signal used to control the LED current (if not used, apply 10-kΩ pull-down to DGND)
PWM3	D26	O ₃	Async	PWM signal used to control the LED current (if not used, apply 10-kΩ pull-down to DGND)
LED_IR_EN	E28	O ₃	Async	IR LED enable strobe. Controlled by programmable DMD sequence timing (active high), (if not used, apply 1-kΩ pull-down to DGND)
LED_RED_EN	F28	O ₃	Async	RED LED enable strobe. Controlled by programmable DMD sequence timing (active high), (if not used, apply 1-kΩ pull-down to DGND)
LED_GRN_EN	E27	O ₃	Async	Green LED enable strobe. Controlled by programmable DMD sequence timing (active high), (if not used, apply 1-kΩ pull-down to DGND)
LED_BLU_EN	F27	O ₃	Async	Blue LED enable strobe. Controlled by programmable DMD sequence timing (active high), (if not used, apply 1-kΩ pull-down to DGND)
LED_SUBFRAME	E26	O ₃	Async	Subframe signal used by LED driver. Controlled by programmable DMD sequence timing (active high), (if not used, apply 1-kΩ pull-down to DGND)
SYNC_0	F26	O ₃	Async	Extra strobe. Controlled by programmable DMD sequence timing (active-high)
SYNC_1	F25	O ₃	Async	Extra strobe. Controlled by programmable DMD sequence timing (active-high)
SYNC_2	F24	O ₃	Async	Extra strobe. Controlled by programmable DMD sequence timing (active-high)
$\overline{\text{LED_EN}}$	L28	O ₃	Async	LED driver enable. Active-low output control to external LED drive logic, recommend 1-kΩ pullup to 3.3 V
LED_SYNC	M21	O ₃	Async	Reserved for future use; weak pullup applied
LED_SYNCEN	C24	O ₃	Async	Inverted $\overline{\text{LED_LIT}}$ signal (if not used, apply 10-kΩ pull-down to DGND)
$\overline{\text{LED_LIT}}$	J28	I ₃	Async	LED driver status, (if not used, apply 1-kΩ pull-down to DGND)
LED_SENS	K27	I ₃	Async	Reserved for future use (if not used, apply 1-kΩ pull-down to DGND)
LED_SPI_CLK	N26	O ₃	Async	LED SPI master clock (if not used, apply 1-kΩ pullup to 3.3 V)
$\overline{\text{LED_SPI_CS}}$	M26	O ₃	LED_SPI_CLK	LED SPI master chip select (if not used, apply 1-kΩ pullup to 3.3 V)
LED_SPI_DIR	P25	O ₃	LED_SPI_CLK	LED SPI master driver direction (if not used, apply 1-kΩ pullup to 3.3 V)
LED_SPI_MISO	L27	I ₃	LED_SPI_CLK	LED SPI master data IN (if not used, apply 1-kΩ pullup to 3.3 V)
LED_SPI_MOSI	L26	O ₃	LED_SPI_CLK	LED SPI master data OUT; weak pullup applied

Pin Functions (continued)

PIN		I/O TYPE ⁽¹⁾	CLOCK SYSTEM	DESCRIPTION
NAME	NUMBER			
SYSTEM INTERFACES				
$\overline{\text{CFG_CSO}}$	E2	O ₃	CFG_DCLK	Chip-select output for an external serial configuration device. Active low
CFG_CLK	P3	O ₃	CFG_DCLK	Configuration serial EPROM data clock
CFG_AS DI	N7	I ₃	CFG_DCLK	Data input from an external serial configuration device. Provides configuration data for the device
CFG_AS DO	F4	O ₃	CFG_DCLK	Serial data output. This pin sends address and control information to the external PROM during configuration.
$\overline{\text{CFG_STATUS}}$	M6	O ₃	CFG_DCLK	Configuration status pin
CFG_DONE	P24	O ₃	CFG_DCLK	Configuration-done status pin. Signal goes high at the end of configuration.
CFG_MSEL0	N22	I ₃	Async	Configuration-mode selection signals
CFG_MSEL1	P23			
CFG_MSEL2	M22			
CFG_MSEL3	P22			
$\overline{\text{CFG_CE}}$	R8	I ₃	Async	Chip enable. Active-low
$\overline{\text{CFG_EN}}$	P4	I ₃	Async	Configuration control. Configuration starts when a low-to-high transition is detected at this pin.
$\overline{\text{CFG_CEO}}$	P28	O ₃	Async	
REF_CLK	J27	I ₃		50-MHz reference clock, 3.3 V
$\overline{\text{RESET}}$	A14	I ₃	Async	Device reset (active-low)
PWR_GOOD	A23	I ₃	Async	System power-good indicator
RESERVED				
RSVD_H10	N4	B ₂		GPIO
RSVD_H11	L2	B ₂		GPIO
RSVD_H12	K4	B ₂		GPIO
RSVD_H6	G1	B ₂		GPIO
RSVD_H5	G5	B ₂		GPIO
RSVD_H4	G6	B ₂		GPIO
RSVD_H2	E1	B ₂		GPIO
RSVD_H1	C2	B ₂		GPIO
RSVD_T0	E22			These I/Os can be left open or unconnected for normal operation.
RSVD_T1	D21			
RSVD_T2	A21			
RSVD_T3	C18			
RSVD_T4	B22			
RSVD_T5	B21			
RSVD_T6	D17			
RSVD_T7	E21			
RSVD_TC	M24			
RSVD_D0	A17	I ₃		
RSVD_D1	D15	O ₃		Reserved for future use, do not connect
RSVD_D2	E17	I ₃		Reserved for future use, do not connect
RSVD_D3	F15	O ₃		Reserved for future use, do not connect
RSVD_H3	E3	I ₃		Reserved for future use, can be left open, recommend grounding
RSVD_H7	H7	I ₃		Reserved for future use, can be left open, recommend grounding
RSVD_H8	L5	I ₃		Reserved for future use, can be left open, recommend grounding
RSVD_H9	M5	I ₃		Reserved for future use, can be left open, recommend grounding

Pin Functions (continued)

PIN		I/O TYPE ⁽¹⁾	CLOCK SYSTEM	DESCRIPTION
NAME	NUMBER			
RESERVED (CONTINUED)				
RSVD_H13	J1	I ₃		Reserved for future use, can be left open, recommend grounding
RSVD_P0	P7	I ₄		Reserved for future use, do not connect
RSVD_P1	P6	O ₂		Reserved for future use, do not connect
RSVD_P2	P8	I ₄		Reserved for future use, do not connect
RSVD_P3	P5	I ₄		Reserved for future use, do not connect
RSVD_G0	C23	O ₃		Reserved for future use, do not connect
RSVD_G1	F19	O ₃		Reserved for future use, do not connect
RSVD_G2	M27	O ₃		Reserved for future use, do not connect
RSVD_G3	N21	O ₃		Reserved for future use, do not connect
RSVD_G4	P27	O ₃		Reserved for future use, do not connect
RSVD_G5	A18	O ₃		Reserved for future use, do not connect
RSVD_G6	A19	O ₃		Reserved for future use, do not connect
RSVD_S1	AG14			Unused input only, can be left open, recommend 10-kΩ pulldown to DGND
RSVD_S2	AG15			Unused input only, can be left open, recommend 10-kΩ pulldown to DGND
RSVD_S3	AH14			Unused input only, can be left open, recommend 10-kΩ pulldown to DGND
RSVD_X11	AH15			Unused input only, can be left open, recommend 10-kΩ pulldown to DGND
RSVD_S20	Y27			Unused input only, can be left open, recommend 10-kΩ pulldown to DGND
RSVD_S21	Y28			Unused input only, can be left open, recommend 10-kΩ pulldown to DGND
RSVD_X9	AA22			Reserved for future use, do not connect
RSVD_S0	AA24			Reserved for future use, can be left open, recommend 10-kΩ pullup to 2.5 V
RSVD_X10	AB23			Reserved for future use, do not connect
RSVD_X6	AB24			Reserved for future use, do not connect
RSVD_X3	AC21			Reserved for future use, do not connect
RSVD_X15	AA17			Reserved, do not leave open, required: 49.4-Ω pullup to 1.8 V
RSVD_X14	AB17			Reserved, do not leave open, required: 49.9-Ω pulldown to DGND
RSVD_X13	U7			Reserved, do not leave open, required: 49.4-Ω pullup to 1.8V
RSVD_X12	U8			Reserved, do not leave open, required: 49.9-Ω pulldown to DGND
RSVD_X2	AE15			Reserved for future use, do not connect
RSVD_X0	AF18			Reserved for future use, do not connect
RSVD_X1	AD15			Reserved for future use, do not connect
RSVD_X8	AF27			Reserved for future use, do not connect
RSVD_X4	AF9			Reserved for future use, do not connect
RSVD_S4	AH26			Reserved for future use, can be left open, recommend 10-kΩ pullup to 1.8 V
RSVD_S5	B25			Reserved for future use, do not connect
RSVD_S6	C20			Reserved for future use, do not connect
RSVD_S8	D19			Reserved for future use, do not connect
RSVD_X5	E24			Reserved for future use, do not connect
RSVD_S10	F22			Reserved for future use, do not connect

Pin Functions (continued)

PIN		I/O TYPE ⁽¹⁾	CLOCK SYSTEM	DESCRIPTION
NAME	NUMBER			
RESERVED (CONTINUED)				
RSVD_S11	K28			Reserved for future use, do not connect
RSVD_S14	N25			Reserved for future use, do not connect
RSVD_X7	R24			Reserved for future use, do not connect
RSVD_S16	R27			Reserved for future use, do not connect
RSVD_S17	R28			Reserved for future use, do not connect
RSVD_S18	U23			Reserved for future use, can be left open, recommend 10-kΩ pullup to 2.5 V
RSVD_S19	U24			Reserved for future use, can be left open, recommend 10-kΩ pullup to 2.5 V
POWER AND GROUND⁽³⁾				
P1P2V		PWR	N/A	1.2-V core power
P2P5V_DPLL		PWR	N/A	2.5-V filtered power for internal PLL
P1P8V		PWR	N/A	1.8-V I/O power
P2P5V		PWR	N/A	2.5-V I/O power
P3P3V		PWR	N/A	3.3-V I/O power
GND		PWR	N/A	Common digital ground
GND A		PWR	N/A	Common PLL ground

(3) Unused inputs should be pulled down to ground through an external resistor.

Power and Ground Pins

PIN		DESCRIPTION
NAME	NUMBER	
INPUT POWER AND GROUND PINS		
VCC_1P2V	K9, K11, K13, K15, K17, K19, L10, L12, L14, L16, L18, L20, M9, M11, M13, M15, M17, M19, N10, N12, N14, N16, N18, N20, P9, P11, P13, P15, P17, P19, R10, R12, R14, R16, R18, R20, T9, T11, T13, T15, T17, T19, U10, U12, U14, U16, U18, U20, V9, V11, V13, V15, V17, V19, W10, W12, W14, W16, W18, W20	1.2-V power supply for core logic
VCC_2P5V	AA28, AG28, T24, T28, W24	2.5-V power supply for I/Os on bank 5
VCC_1P8V	AA1, AG1, T1, T5, W5, AA11, AD6, AD9, AD13, AH2, AH5, AH9, AH13, AA18, AD16, AD20, AD23, AH16, AH20, AH24, AH27	1.8-V power supply for I/Os on banks 2, 3, 4
VCC_3P3V	B1, H1, K5, N1, N5, B28, H28, K24, N24, N28 A16, A20, A24, A27, E16, E20, E23, H18, A2, A5, A9, A13, E6, E9, E13, H11	3.3-V power supply for I/Os on banks 1, 6, 7, 8
VCCA	Y8, J21, J8, Y21	2.5-V power supply for the internal PLL analog supply
VCCD_PLL	Y9, J20, J9, Y20	1.2-V power supply for the internal PLL digital supply
VREF_B2	T7, T8, AB4	DDR2 VREF 0.9 V. The SDRAM specification provides guidelines on how these references should be connected. It is not just any 0.9-V source on the board.
VREF_B3	AB13, AB11, Y10	DDR2 VREF 0.9 V. The SDRAM specification provides guidelines on how these references should be connected. It is not just any 0.9-V source on the board.
VREF_B4	AB20, AC18, AA15	DDR2 VREF 0.9 V. The SDRAM specification provides guidelines on how these references should be connected. It is not just any 0.9-V source on the board.
DGND	K10, K12, K14, K16, K18, K20, L9, L11, L13, L15, L17, L19, M10, M12, M14, M16, M18, M20, N9, N11, N13, N15, N17, N19, P10, P12, P14, P16, P18, P20, R9, R11, R13, R15, R17, R19, T10, T12, T14, T16, T18, T20, U9, U11, U13, U15, U17, U19, V10, V12, V14, V16, V18, V20, W9, W11, W13, W15, W17, W19, AA2, AA27, AC6, AC9, AC13, AC16, AC20, AC23, AF1, AF28, AG2, AG5, AG9, AG13, AG16, AG20, AG24, AG27, B2, B5, B9, B13, B16, B20, B24, B27, C1, C28, F6, F9, F13, F16, F20, F23, H2, H27, J11, J18, K6, K23, N2, N6, N23, N27, T2, T6, T23, T27, W6, W23, Y11, Y18	Common ground
DGND2	H9, H20, AA9, AA20	Analog ground return for the PLL (This should not be connected to the common ground GND.)
NC	C3, F7, G7, G8, G10, G11, G19, G20, G21, G22, G23, G24, H8, H10, H12, H14, H15, H16, H17, H19, H21, H22, J5, J6, J7, J10, J12, J13, J14, J15, J16, J17, J19, J23, J24, K7, K8, K21, K22, L6, L7, L8, L21, L22, M7, M8, M23, N8, P21, R7, R21, R22, R23, U21, U22, V5, V6, V7, V8, V21, V22, W4, W7, W8, W21, W22, Y5, Y6, Y7, Y12, Y13, Y14, Y15, Y16, Y17, Y22, AA5, AA6, AA7, AA12, AA13, AA14, AA19, AA21, AA23, AB10, AB12, AB14, AB15, AB18, AB19, AB21, AB22, AC10, AC12, AC14, AC19, AC22, AD14, AD19, AD22, AE26	No-connect pins

6 Specifications

6.1 Absolute Maximum Ratings⁽¹⁾

Over operating free-air temperature range (unless otherwise noted)

		MIN	MAX	UNIT
V _{CC12}	Supply voltage ⁽²⁾	-0.5	1.8	V
V _{CCIO18}		-0.5	3.9	
V _{CCA25_DPLL}		-0.5	3.75	
V _{CCD_PLL1-4}		-0.5	1.8	
V _I	Input voltage ⁽³⁾ (1.8 V, 2.5 V, 3.3 V)	-0.5	3.95	V
T _J	Operating junction temperature	-40	125	°C

- (1) Stresses beyond those listed under *Absolute Maximum Ratings* may cause permanent damage to the device. These are stress ratings only, and functional operation of the device at these or any other conditions beyond those indicated under *Recommended Operating Conditions* is not implied. Exposure to absolute-maximum-rated conditions for extended periods may affect device reliability.
- (2) All voltage values are with respect to GND, and at the device, not at the power supply.
- (3) Applies to external input and bidirectional buffers.

6.2 Handling Ratings

		MIN	MAX	UNIT	
T _{stg}	Storage temperature range	-65	150	°C	
V _(ESD)	Electrostatic discharge	Human body model (HBM), per ANSI/ESDA/JEDEC JS-001, all pins ⁽¹⁾	-2000	2000	V
		Charged device model (CDM), per JEDEC specification JESD22-C101, all pins ⁽²⁾	-500	500	

- (1) JEDEC document JEP155 states that 500-V HBM allows safe manufacturing with a standard ESD control process.
- (2) JEDEC document JEP157 states that 250-V CDM allows safe manufacturing with a standard ESD control process.

6.3 Recommended Operating Conditions

Over operating free-air temperature range (unless otherwise noted)

		MIN	NOM	MAX	UNIT
V _{CC12}	1.2-V supply voltage, core logic	1.15	1.2	1.25	V
V _{CC18}	1.8-V supply voltage, HSTL output buffers	1.71	1.8	1.89	V
V _{CCA25_DPLL}	2.5-V analog voltage for PLL regulator	2.375	2.5	2.625	V
V _{CCD_PLL1-4}	1.2-V supply voltage, for PLL	1.15	1.2	1.25	V
V _{CC33}	3.3-V supply voltage	3.135	3.3	3.465	V
V _{REF_B2-4}	0.9-V reference voltage, for DDR2 SDRAM	0.833	0.9	0.969	V
V _I	Input voltage	-0.5		3.6	V
V _O	Output voltage	0		V _{CCIO}	V
t _{Ramp}	Power supply ramp time	50 μs		3 ms	—
T _J	Operating junction temperature ⁽¹⁾	-20		85	°C

- (1) Heat sink not required for 0°C to 55°C, but for 55°C to 85°C, TI recommends a low-profile (15-mm) heat sink.

6.4 Thermal Information

THERMAL METRIC ⁽¹⁾		DLPC200	UNIT	
		BGA		
		780 PINS		
R _{θJA}	Junction-to-ambient thermal resistance	Natural convection	16.9	°C/W
		100 CFM	13.5	
		200 CFM	11.8	
		400 CFM	10.5	
R _{θJC(top)}	Junction-to-case (top) thermal resistance	3.3		
R _{θJB}	Junction-to-board thermal resistance	5.9		

- (1) For more information about traditional and new thermal metrics, see the *IC Package Thermal Metrics* application report, [SPRA953](#).

6.5 I/O Electrical Characteristics

All inputs and outputs are LVCMOS

I/O TYPE ⁽¹⁾	TEST CONDITIONS	V _{IL} (V)		V _{IH} (V)		V _{OH} (V)	V _{OL} (V)	UNIT
		MIN	MAX	MIN	MAX	MIN	MAX	
I ₁ Input LVCMOS	V _{CCIO} = 1.8 V	-0.3	0.35 × V _{CCIO}	0.65 × V _{CCIO}	2.25			V
I ₂ Input LVCMOS	V _{CCIO} = 2.5 V	-0.3	0.7	1.7	V _{CCIO} + 0.3			V
I ₃ Input LVCMOS	V _{CCIO} = 3.3 V	-0.3	0.8	1.7	3.6			V
I ₄ Input LVTTTL	V _{CCIO} = 3.3 V	-0.3	0.8	1.7	3.6			V
O ₁ Output LVCMOS	V _{CCIO} = 1.8 V					V _{CCIO} - 0.45	0.45	V
O ₂ Output LVTTTL	V _{CCIO} = 3.3 V					2.4	0.45	V
O ₃ Output LVCMOS	V _{CCIO} = 3.3 V					V _{CCIO} - 0.2	0.2	V
O ₄ Output LVDS	V _{CCIO} = 3.3 V					V _{CCIO} - 0.3	0.3	V
O ₅ Output SSTL-18 Class I	V _{CCIO} = 1.8 V					1.484	0.398	V
B ₁ Bidirectional SSTL-18 Class I	V _{CCIO} = 1.8 V		0.844	1.094		1.484	0.398	V
B ₂ Bidirectional LVCMOS	V _{CCIO} = 3.3 V	-0.3	0.8	1.7	3.6	V _{CCIO} - 0.2	0.2	V

(1) Cross reference to I/O assignments

6.6 Video Input Pixel Interface Timing Requirements

PARAMETER	TEST CONDITIONS	MIN	MAX	UNIT
f _{pclock} Clock frequency, PORTx_CLK			80	MHz
t _{p_wh} Pulse duration, high	45% to 55% reference points (signal)	5.6		ns
t _{p_wl} Pulse duration, low	45% to 55% reference points (signal)	5.6		ns
t _{p_su} Setup time, PORTx_D(23-0) valid before PORTx_CLK	See ⁽¹⁾	1.5		ns
t _{p_h} Hold time, PORTx_D(23-0) valid after PORTx_CLK	See ⁽¹⁾	1.5		ns
t _{p_su} Setup time, PORTx_VSYNC valid before PORTx_CLK	See ⁽¹⁾	1.5		ns
t _{p_h} Hold time, PORTx_VSYNC valid after PORTx_CLK	See ⁽¹⁾	1.5		ns
t _{p_su} Setup time, PORTx_HSYNC valid before PORTx_CLK	See ⁽¹⁾	1.5		ns
t _{p_h} Hold time, PORTx_HSYNC valid after PORTx_CLK	See ⁽¹⁾	1.5		ns
t _{p_su} Setup time, PORTx_IVALID valid before PORTx_CLK	See ⁽¹⁾	1.5		ns
t _{p_h} Hold time, PORTx_IVALID valid after PORTx_CLK	See ⁽¹⁾	1.5		ns

(1) PCLK may be inverted from that shown in [Figure 1](#). In that case, the same specifications in the table are valid except now referenced to the falling edge of the clock. If the falling edge of PCLK is used, a USB or SPI command must be sent to tell the DLPC200 to use the falling edge of PCLK.

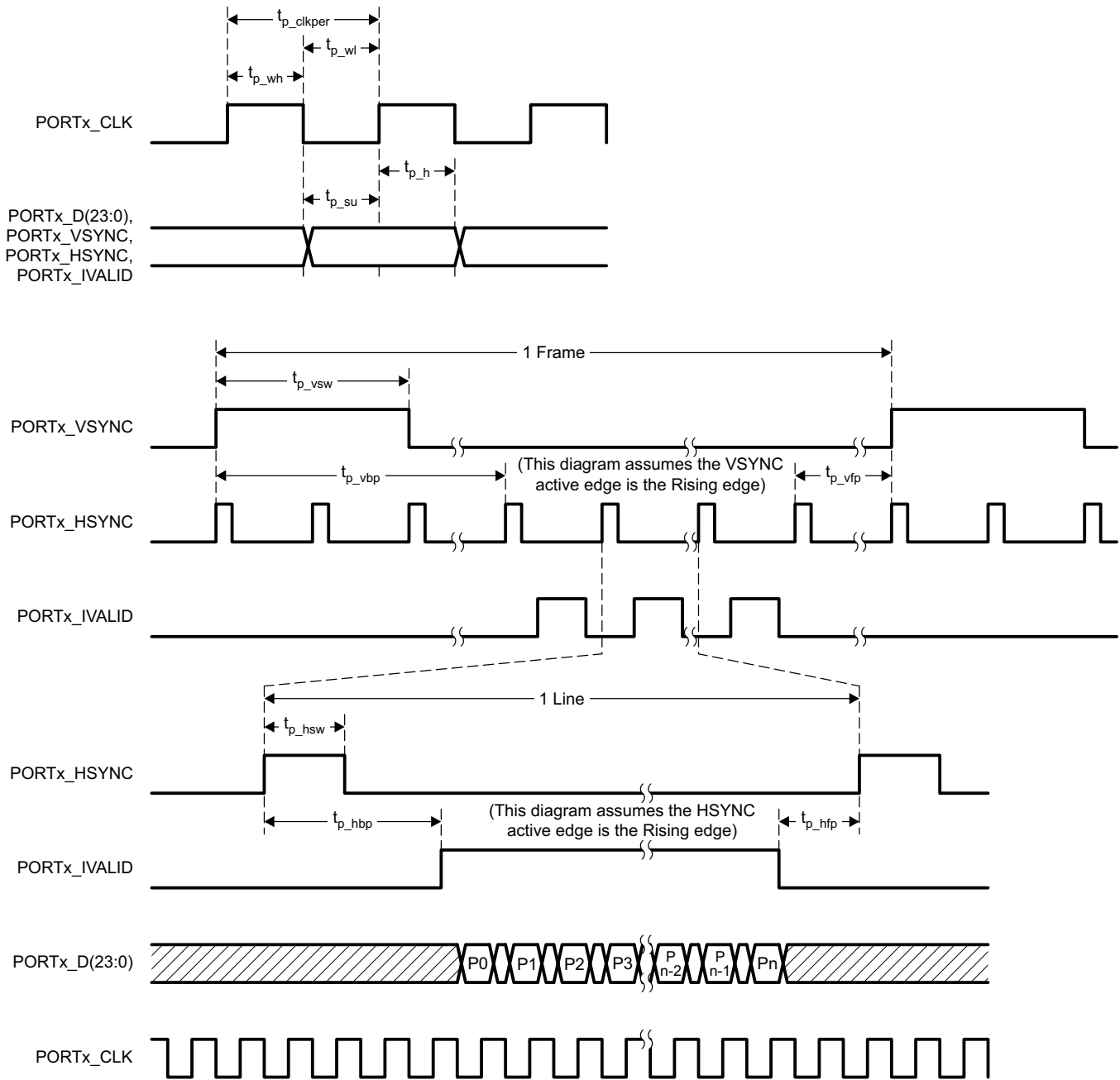

Figure 1. Input Port Interface

See [Pin Configuration and Functions](#) for the proper connection schema if a video input port will not be used.

6.7 I²C Interface Timing Requirements

PARAMETER		MIN	MAX	UNIT
f_{scl}	I ² C clock frequency	0	400	kHz
t_{sch}	I ² C clock high time	1		ms
t_{scl}	I ² C clock low time	1		ms
t_{sp}	I ² C spike time		20	ns
t_{sds}	I ² C serial-data setup time	100		ns
t_{sdh}	I ² C serial-data hold time	100		ns
t_{icr}	I ² C input rise time	100		ns
t_{ocf}	I ² C output fall time	30	200	ns
t_{buf}	I ² C bus free time between stop and start conditions	1.3		ms
t_{sts}	I ² C start or repeat start condition setup	1		ms
t_{sth}	I ² C start or repeat start condition hold	1		ms
t_{sph}	I ² C stop condition setup	1		ms
t_{vd}	Valid-data time	SCL low to SDA output valid		1 ms
	Valid-data time of ACK condition	ACK signal from SCL low to SDA (out) low		1 ms
t_{sch}	I ² C bus capacitive load	0	100	pF

6.8 USB Read Interface Timing Requirements

PARAMETER		MIN	TYP	MAX	UNIT
t_{CL}	1 / CLKOUT frequency		20.8		ns
t_{AV}	Delay from clock to valid address			10.7	ns
t_{STBL}	Clock to USB_RDY0 LOW			11	ns
t_{STBH}	Clock to USB_RDY0 HIGH			11	ns
t_{SCSL}	Clock to USB_PA02 LOW			13	ns
t_{DSU}	Data setup to clock	9.6			ns
t_{DH}	Data hold time	0			ns
t_{ACC1}	Valid USB_PA04 to valid USB_FDC	43			ns

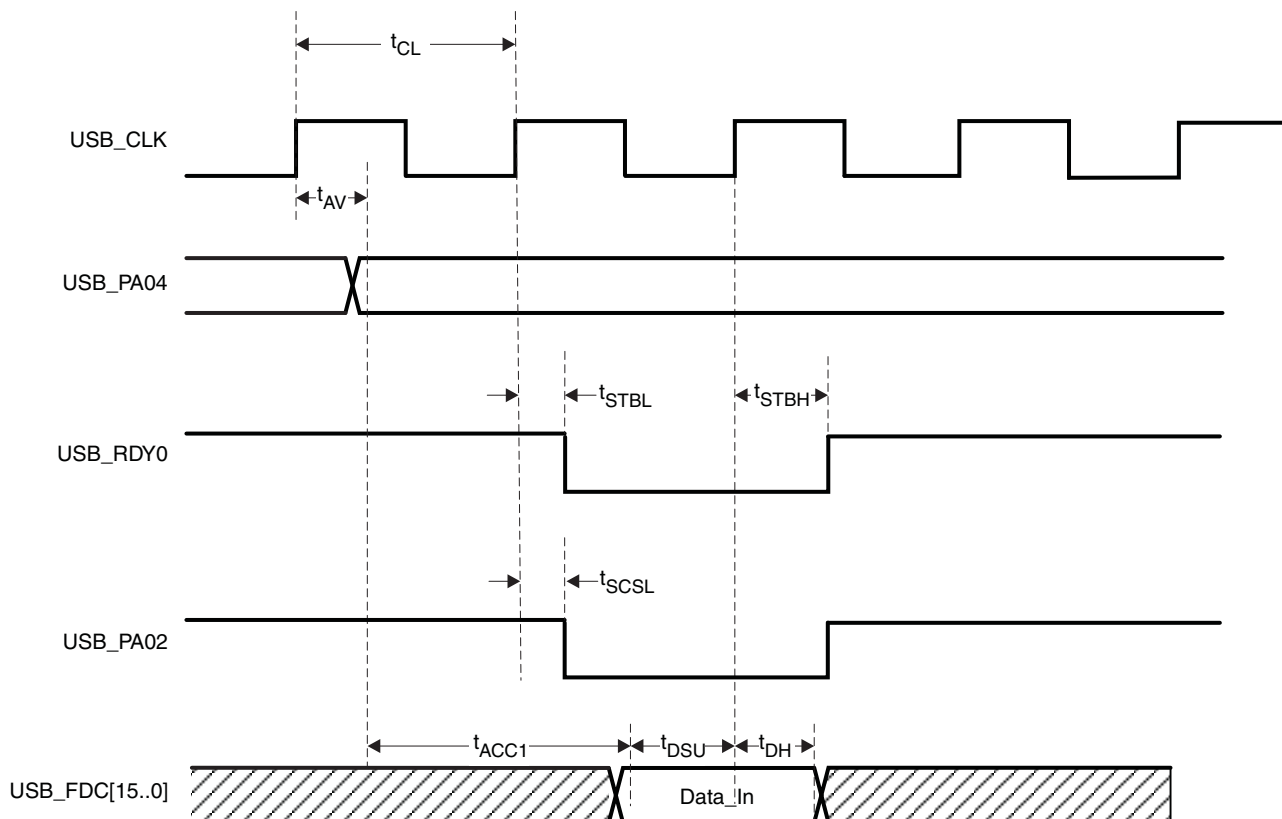

Figure 3. USB Read Timing

6.9 USB Write Interface Timing Requirements

PARAMETER		MIN	MAX	UNIT
t_{AV}	Delay from clock to valid address	0	10.7	ns
t_{STBL}	Clock to USB_RDY1 pulse LOW	0	11.2	ns
t_{STBH}	Clock to USB_RDY1 pulse HIGH	0	11.2	ns
t_{SCSL}	Clock to USB_PA02 pulse LOW		13	ns
t_{ON1}	Clock to data turn on	0	13.1	ns
t_{OFF1}	Clock to data hold time	0	13.1	ns

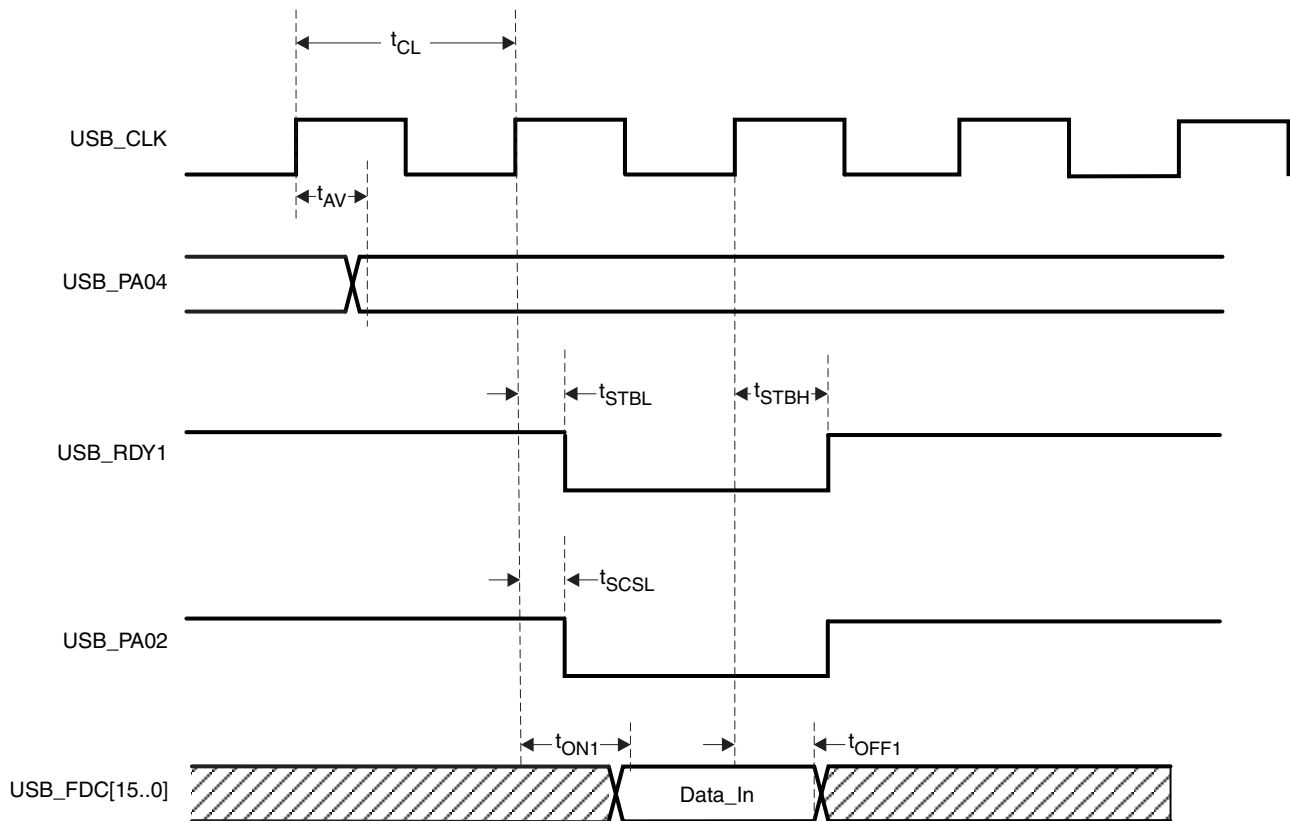

Figure 4. USB Write Timing

See [Pin Configuration and Functions](#) for the proper connection schema if the USB interface will not be used.

6.10 SPI Slave Interface Timing Requirements

PARAMETER		MIN	MAX	UNIT
f_{clock}	Clock frequency, SLAVE_SPI_CLK		5	MHz
$t_{\text{p_clkper}}$	Clock period, SLAVE_SPI_CLK	200		ns
$t_{\text{p_wh}}$	Pulse duration high, SLAVE_SPI_CLK	10		ns
$t_{\text{p_wl}}$	Pulse duration low, SLAVE_SPI_CLK	10		ns
$t_{\text{c_su}}$	Setup time, SLAVE_SPI_CS	6		ns
$t_{\text{c_h}}$	Hold time, SLAVE_SPI_CS	3		ns
$t_{\text{i_su}}$	Setup time, SLAVE_SPI_MOSI	10		ns
$t_{\text{i_h}}$	Hold time, SLAVE_SPI_MOSI	10		ns
$t_{\text{o_su}}$	Setup time, SLAVE_SPI_MISO	10		ns
$t_{\text{o_h}}$	Hold time, SLAVE_SPI_MISO	10		ns
$t_{\text{a_su}}$	Setup time, SLAVE_SPI_ACK	7		ns
$t_{\text{a_h}}$	Hold time, SLAVE_SPI_ACK	7		ns

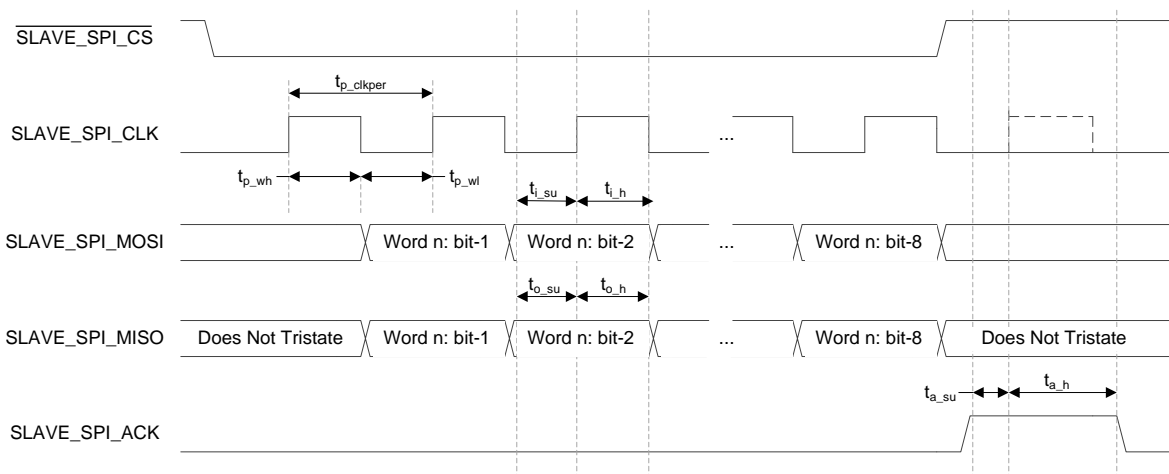

Figure 5. SPI Timing

6.11 Parallel Flash Interface Timing Requirements

PARAMETER		MIN	MAX	UNIT
t_{AVAV}	Read cycle time		110	ns
t_{AVQV}	Address to output valid		110	ns
t_{ELQV}	\overline{CE} low to output valid		110	ns
t_{GLQV}	\overline{OE} low to output valid		25	ns
t_{PHQV}	\overline{RST} high to output valid		150	ns
t_{GLTV}	\overline{OE} low to \overline{WAIT} valid		17	ns
t_{PHWL}	\overline{RST} high recovery to \overline{WE} low	150		ns
t_{ELWL}	\overline{CE} setup to \overline{WE} low	0		ns
t_{WLWH}	\overline{WE} write pulse width low	50		ns
t_{DVWH}	Data setup to \overline{WE} high	50		ns
t_{AVWH}	Address setup to \overline{WE} high	50		ns
t_{WHEH}	\overline{CE} hold from \overline{WE} high	0		ns
t_{PWDHX}	Data hold from \overline{WE} high	0		ns
t_{WHAX}	Address hold from \overline{WE} high	0		ns

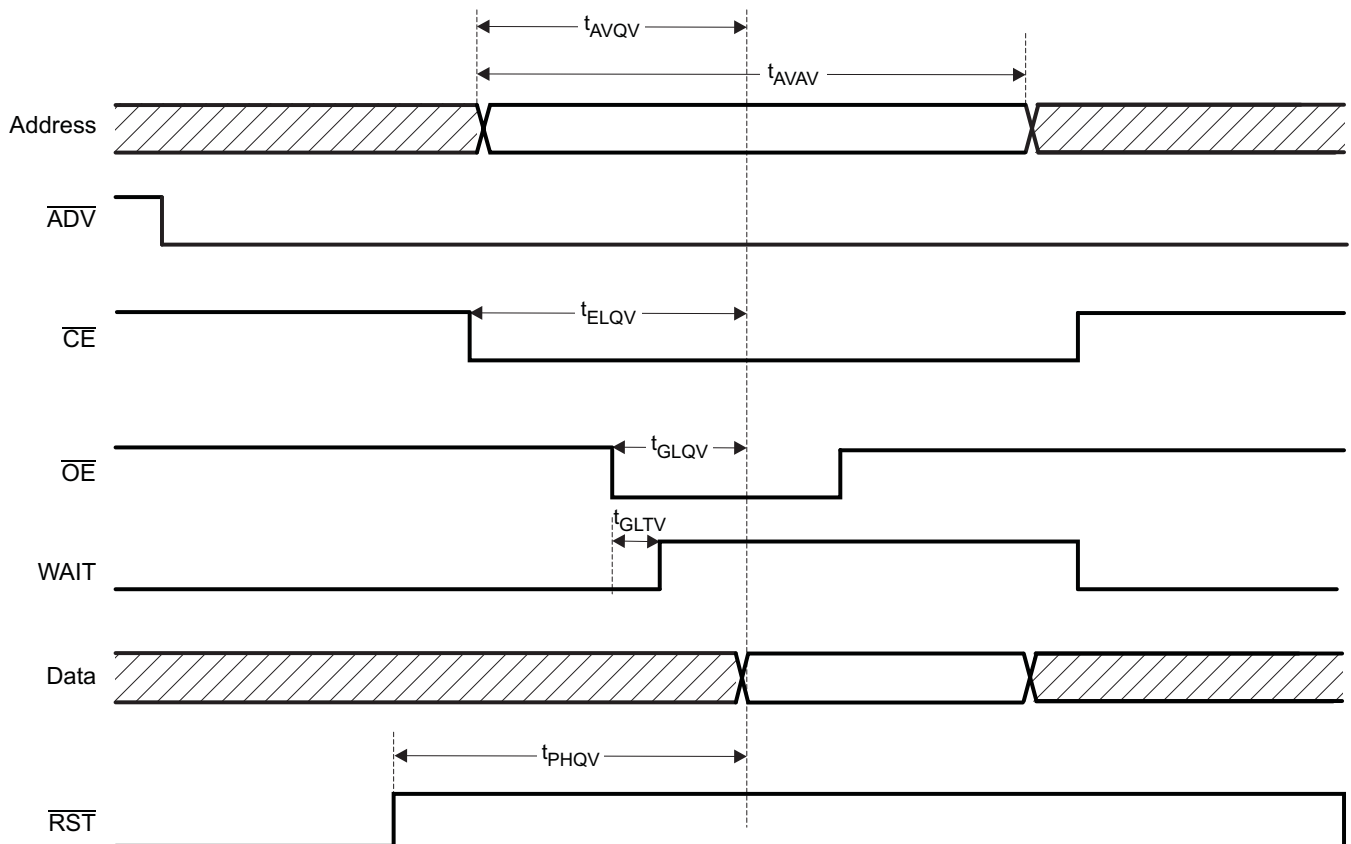

Figure 6. Parallel Flash Read Timing

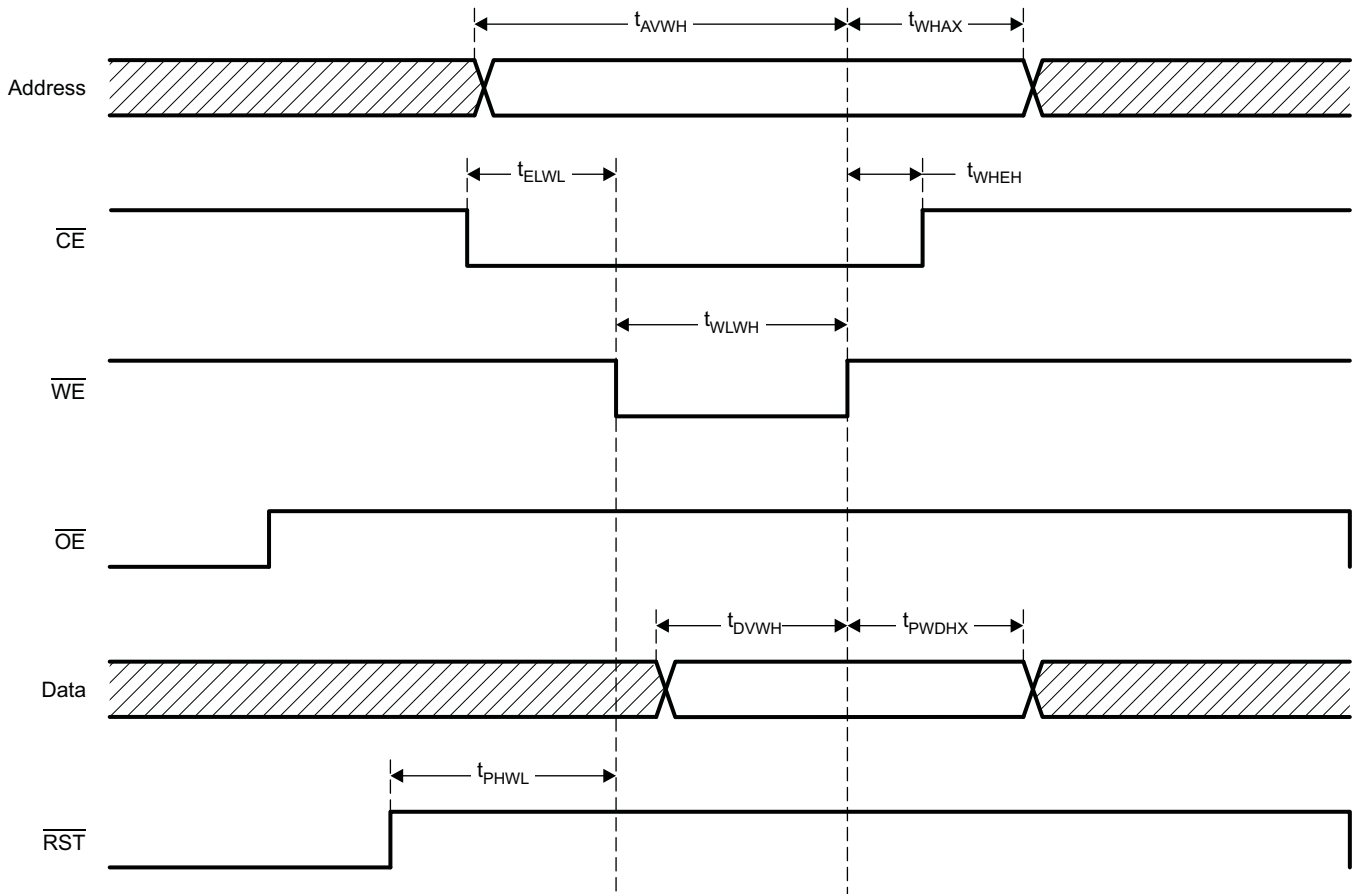

Figure 7. Parallel Flash Write Timing

6.12 Serial Flash Interface Timing Requirements

The DLPC200 controller flash memory interface consists of a SPI flash serial interface at 33.3 MHz (nominal).

PARAMETER		MIN	MAX	UNIT
f_{clock}	Clock frequency, CFG_CLK	dc	33	MHz
t_{p_clkper}	Clock period, CFG_CLK		30.03	ns
t_{p_wh}	Pulse duration low, CFG_CLK	6		ns
t_{p_wl}	Pulse duration high, CFG_CLK	6		ns
t_{p_su}	Setup time – CFG_ASDI/CFG_ASDO valid before CFG_CLK rising edge	2		ns
t_{p_h}	Hold time – CFG_ASDI/CFG_ASDO valid after CFG_CLK rising edge	5		ns

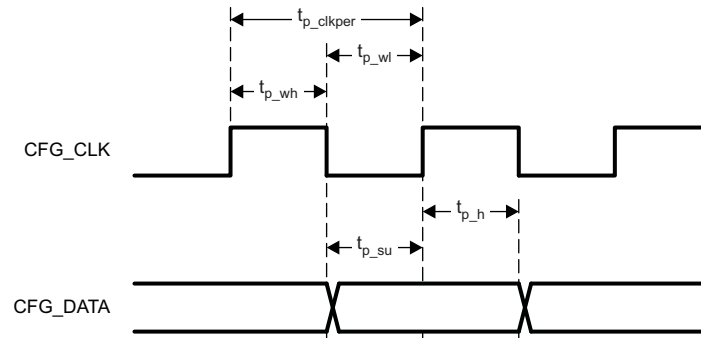

Figure 8. Flash Memory Interface Timing

6.13 Static RAM Interface Timing Requirements

The DLPC200 controller static RAM (SRAM) interface consists of a high performance CMOS SRAM organized as 128K words by 16 bits (2 Mb).

PARAMETER		MIN	MAX	UNIT
t_{RC}	Read cycle time	10		ns
t_{AA}	Address to data valid		10	ns
t_{OHA}	Data hold from address change	3		ns
t_{WC}	Write cycle time	10		ns
t_{SCE}	CE low to write end	7		ns
t_{AW}	Address setup to write end	7		ns
t_{HA}	Address hold from write end	0		ns
t_{SA}	Address setup to write start	0		ns
t_{PWE}	WE pulse duration	7		ns
t_{SD}	Data setup to write end	5		ns
t_{HD}	Data hold from write end	0		ns

6.14 DMD Interface Timing Requirements

The DLPC200-DMD interface consists of a 200 MHz (nominal) DDR output-only interface with LVDS signaling.

PARAMETER		MIN	TYP	MAX	UNIT
f_{clock}	Clock frequency, DCLK_A and DCLK_B		200		MHz
t_{p_clkper}	Clock period, DCLK_A and DCLK_B		5		ns
t_{p_wh}	Pulse duration low, DCLK_A and DCLK_B		1.25		ns
t_{p_wl}	Pulse duration high, DCLK_A and DCLK_B		1.25		ns
t_{skew}	Channel B relative to channel A	-1.25		1.25	ns
t_{p_su}	Output setup time – D_A(0:15) and D_B(0:15) relative to both rising and falling edges of DCLK_A and DCLK_B, respectively	0.35			ns
t_{p_h}	Output hold time – D_A(0:15) and D_B(0:15) relative to both rising and falling edges of DCLK_A and DCLK_B, respectively	0.35			ns

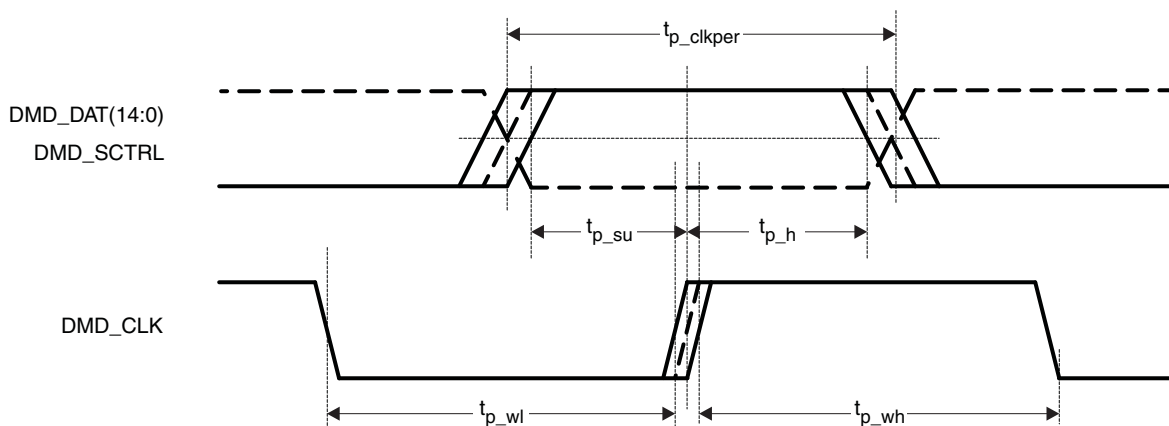

Figure 9. DMD I/F Timing

6.15 DLPA200 Interface Timing Requirements

The DLPC200 interface to the DLPA200 consists of a 125 kHz (nominal) serial communications port (SCP).

PARAMETER		MIN	TYP	MAX	UNIT
f_{clock}	Clock frequency		125	125	kHz
$t_{\text{p_clkper}}$	Clock period			8	us
$t_{\text{p_wh}}$	Pulse duration low			4	us
$t_{\text{p_wl}}$	Pulse duration high			4	us
$t_{\text{p_su}}$	SCPDI setup time	7.3			ns
$t_{\text{p_h}}$	SCPDI hold time	5.7			ns

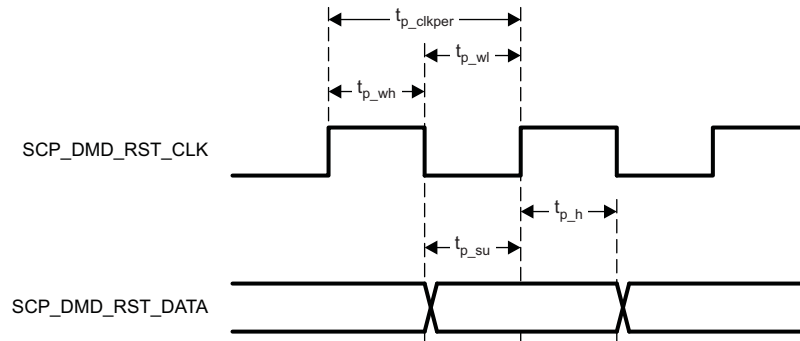

Figure 10. DLPA200 I/F Timing

6.16 DDR2 SDR Memory Interface Timing Requirements

PARAMETER		MIN	MAX	UNIT
t_{CYCLE}	Cycle time reference	5	8	ns
t_{CH}	CK high pulse duration ⁽¹⁾	2.4	4.16	ns
t_{CL}	CK low pulse duration ⁽¹⁾	2.4	4.16	ns
t_{CMS}	Command setup	200		ps
t_{CMH}	Command hold	275		ps
t_{AS}	Address setup	400		ps
t_{AH}	Address hold	400		ps
t_{DS}	Write data setup	1.5		ns
t_{DH}	Write data hold	1.5		ns
t_{AC}	Read data access time	-450	450	ps
t_{OH}	Read data hold time		340	ps
t_{LZ}	Read data low-impedance time	-900	450	ps
t_{HZ}	Read data high-impedance time		450	ps

(1) Output setup/hold numbers already account for controller clock jitter. Only routing skew and memory setup/hold need be considered in system timing analysis.

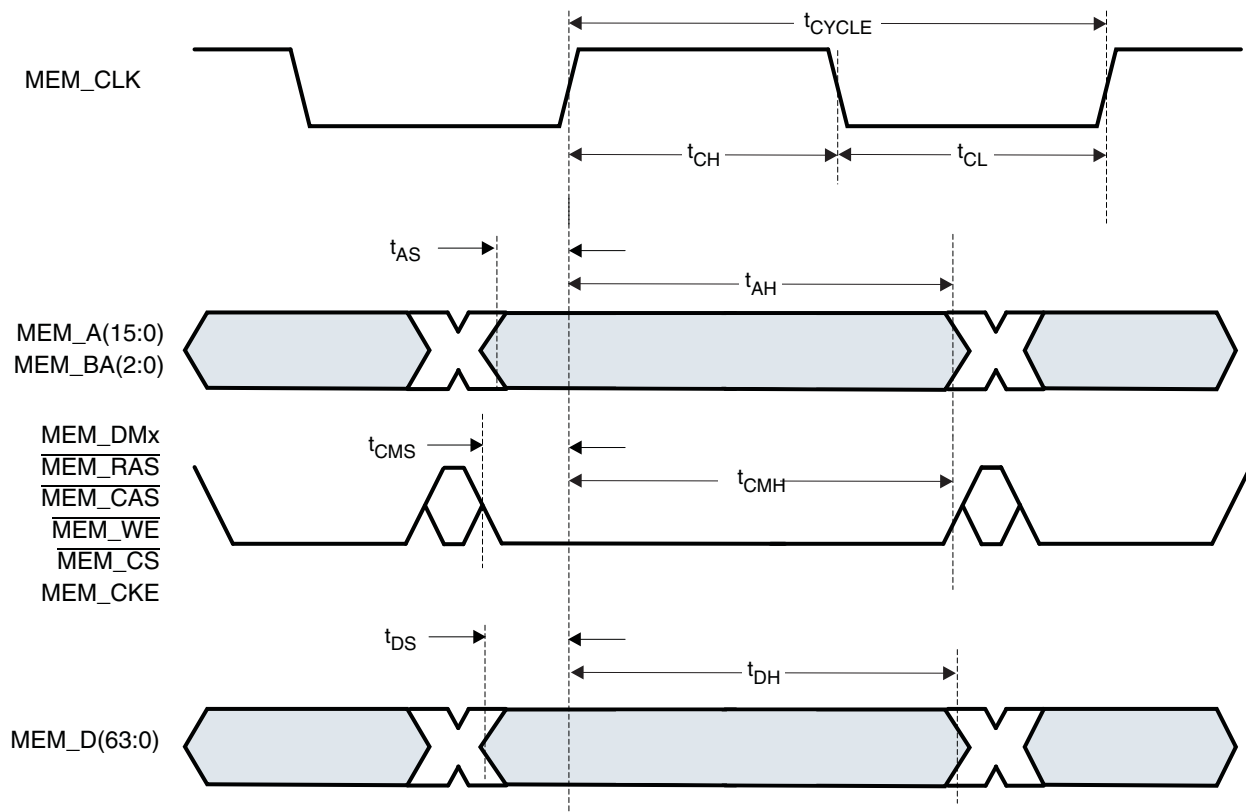

Figure 11. SDR Memory I/F Write Timing

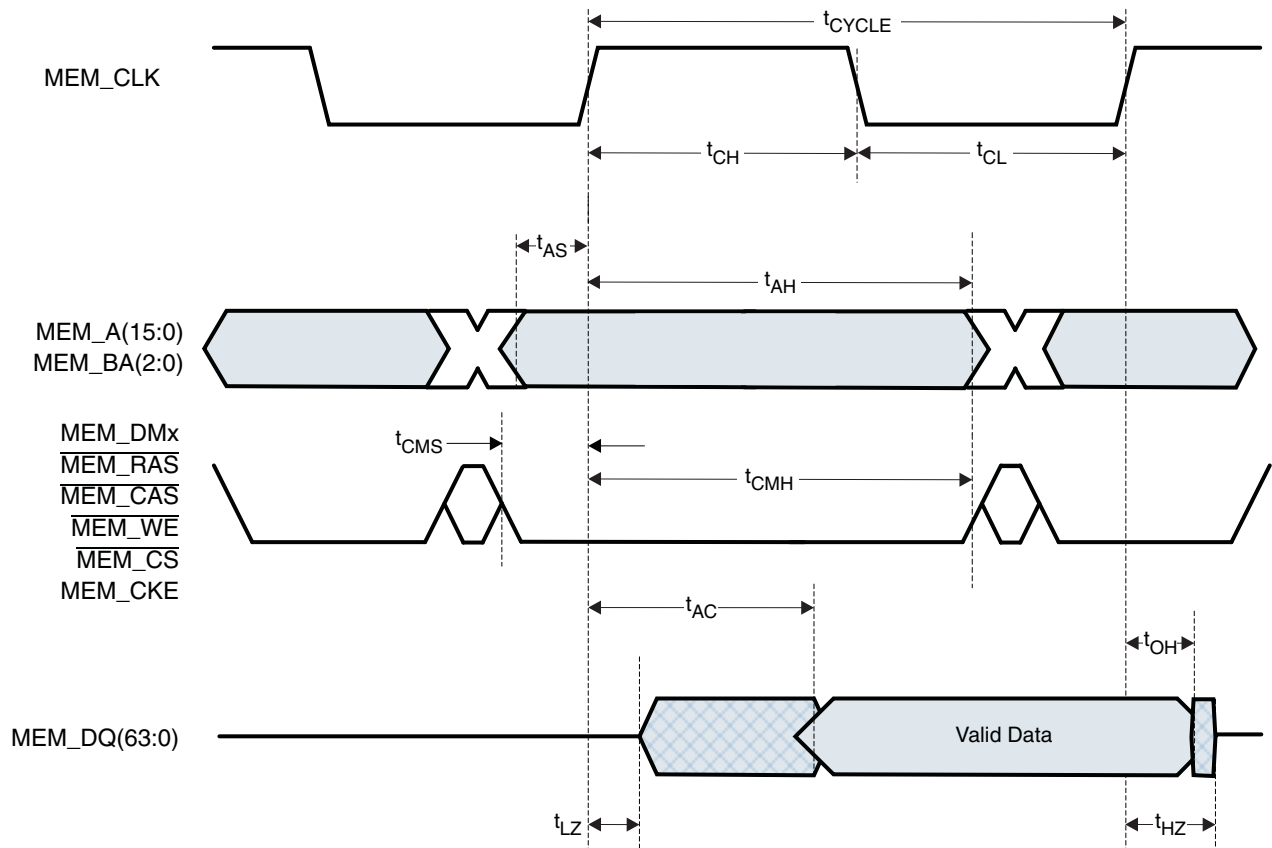

Figure 12. SDR Memory I/F Read Timing

6.17 Video Input Pixel Interface – Image Sync and Blanking Requirements

Figure 13 shows how pixels should be mapped to the input data bus for both port 1 and port 2.

PARAMETER		MIN	MAX	UNIT
t_{p_vsw}	Vertical sync duration	1		clocks
t_{p_vbp}	Vertical back porch	14		lines
t_{p_vfp}	Vertical front porch	2		lines
t_{p_hsw}	Horizontal sync duration	1		clocks
t_{p_hbp}	Horizontal back porch	64		clocks
t_{p_hfp}	Horizontal front porch	75		clocks

24-Bit Input Bus, RGB888

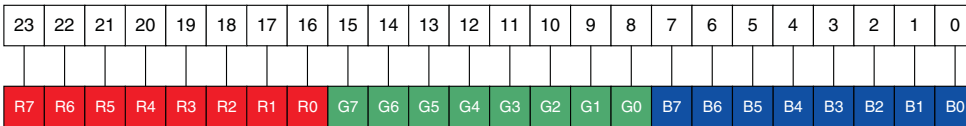

PORTx_D(23:0) of the Input Pixel Data Bus
Default Bus Assignment Mapping

RGB888 Format

Figure 13. Pixel Mapping

7 Detailed Description

7.1 Overview

In DLP-based solutions, image data is 100% digital from the DLPC200 inputs to the image on the DMD. Patterns stay in digital form and are not converted into an analog signal. The DLPC200 controller processes the digital input and converts the data into a format needed by the DMD. The DMD steers light by using binary pulse-duration modulation (PWM) for each micromirror. For further details, refer to DMD data sheet (DLPS013 for the DLP5500 DMD).

The DLPC200 only accepts 1024 × 768 (XGA) formatted data for both video and structured light modes. The functionality of this controller is well-suited for techniques such as structured light, additive manufacturing, or digital exposure.

7.2 Functional Block Diagram

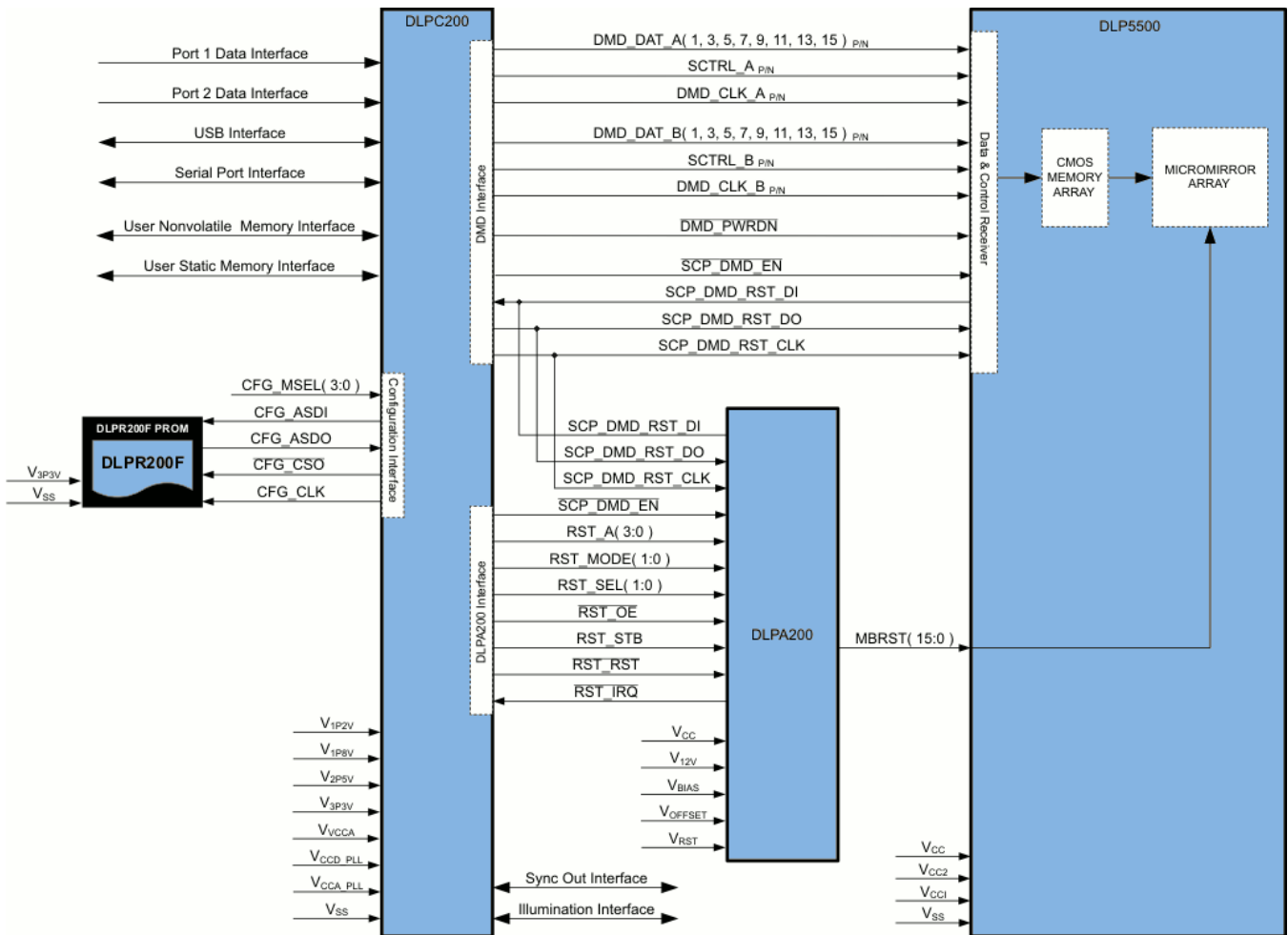

7.3 Feature Description

7.3.1 Frame Rates

The digital input interface levels for image data are nominally 1.8 or 3.3 V. Port 1 input is 3.3 V and port 2 input is 1.8 V.

[DLPR200F firmware](#) is provided by TI to support the operation of video and structured light mode.

Feature Description (continued)
Table 1. Frame Rates

MODE		MIN	MAX	UNIT
Structured light	1 bit per pixel	6	5000	Hz
	8 bits per pixel	6	700	
Video		6	60	Hz

7.4 Device Functional Modes

The DLPC200 has two basic functional mode types: video and structured light.

7.4.1 Video Modes

The controller accepts RGB-8-8-8 input to port 1 or port 2 through a selectable MUX. XGA video information is displayed on the DMD at 6 to 60 fps.

An internal pattern generator can generate RGB-8-8-8 video patterns into an internal selectable MUX for verification and debug purposes.

7.4.2 Structured Light Modes

The DLPC200 provides two structured light modes: static image buffer and real-time structured light.

7.4.2.1 Static Image Buffer Mode

Image data can be loaded into parallel flash memory to load to DDR2 memory at startup to be displayed, or can be loaded over USB or the SPI port directly to DDR2 memory to be displayed. Binary (1-bit) or grayscale (8-bit) patterns can be displayed. The memory will hold 960 binary patterns or 120 grayscale patterns.

7.4.2.2 Real Time Structured Light Mode

RGB-8-8-8 60 fps data can be input into port 1 or port 2 and reinterpreted as up to 24 binary (1-bit) patterns or three grayscale (8-bit) patterns. The specified number of patterns is displayed equally during the exposure time specified. Any unused RGB-8-8-8 data in the video frame must be filled with data, usually 0s.

For example, during one video frame (16.67 ms), 12 binary patterns of the 24 RGB bits are requested to be displayed during half of the video frame time (exposure time = 8.33 ms). Each of the eight red bits and the four most significant green bits are displayed as a binary pattern for 694 μ s each. The remaining bits are ignored and the remaining 8.33 ms of the frame will be dark.

8 Application and Implementation

8.1 Application Information

The DLPC200 is used in conjunction with the DLPA200 driver to drive the DLP5500 (0.55-inch XGA DMD). This combination can be used for a number of applications from 3D printers to microscopes.

The most common application is for 3D structured light measurement applications. In this application, patterns (binary, grayscale, or even full color) are projected onto the target and the distortion of the patterns are recorded by an imaging device to extract 3D (x, y, z) surface information.

8.2 Typical Application

A schematic is shown in [Figure 14](#) for projecting RGB and IR structured light patterns onto a measurement target. Typically, an imaging device is triggered through one of the three syncs to record the data as each pattern is displayed.

Typical Application (continued)

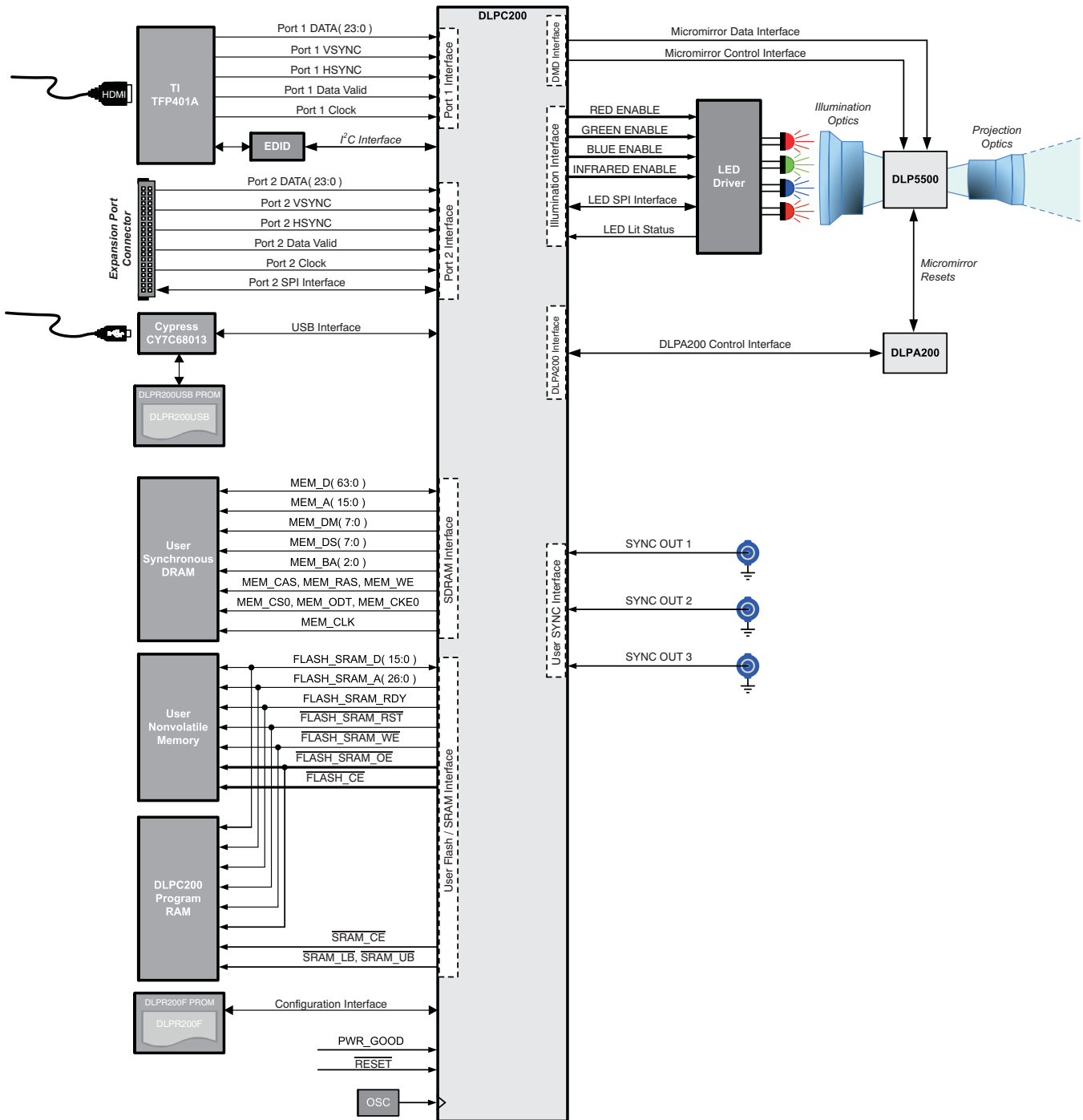

Figure 14. Typical RGB + IR Structured Light Application

8.2.1 Design Requirements

All applications using the DLP 0.55-inch XGA chipset require the DLPC200 controller, the DLPA200 driver, and the DLP5500 DMD for correct operation. The system also requires user supplied SRAM and a configuration PROM programmed with the DLPR200F program file and a 50-MHz oscillator is for operation.

Typical Application (continued)

8.2.2 Detailed Design Procedure

8.2.2.1 DLPC200 System Interfaces

The DLPC200 supports the following interfaces: extended display identification data (EDID), USB, SPI, parallel flash, serial flash, DDR2 SDRAM, and two RGB888 input ports, which are described in the following subsections.

8.2.2.1.1 DLPC200 Master, I²C Interface for EDID Programming

The DLPC200 controller I²C interface is only used to program the HDMI EDID. Upon plugging in an HDMI source, the DMD resolution is compared to the HDMI output resolution programmed in the HDMI EDID PROM. If the two resolutions do not match, then the HDMI EDID is adjusted to match the DMD resolution.

The bidirectional I²C bus consists of the serial clock (SCL) and serial data (SDA) lines. Both lines must be connected to a positive supply through a pullup resistor when connected to the output stages of a device. Data transfer may be initiated only when the bus is not busy.

I²C communication with this device is initiated by a master sending a Start condition, a high-to-low transition on the SDA input/output while the SCL input is high. After the Start condition, the device address byte is sent, MSB first, including the data direction bit (R/W).

After receiving the valid address byte, this device responds with an ACK, a low on the SDA input/output during the high of the ACK-related clock pulse.

On the I²C bus, only one data bit is transferred during each clock pulse. The data on the SDA line must remain stable during the high pulse of the clock period, as changes in the data line at this time are interpreted as control commands (Start or Stop). A Stop condition (a low-to-high transition on the SDA input/output while the SCL input is high) is sent by the master.

Any number of data bytes can be transferred from the transmitter to the receiver between the Start and Stop conditions. Each byte of eight bits is followed by one ACK bit. The transmitter must release the SDA line before the receiver can send an ACK bit. The device that acknowledges must pull down the SDA line during the ACK clock pulse so that the SDA line is stable low during the high pulse of the ACK-related clock period. Setup and hold times must be met to ensure proper operation.

Table 2. Recommended EDID PROM Devices

PART NUMBER	MANUFACTURER
24LC02B	Microchip Technology

8.2.2.1.2 USB Interface

The USB interface consists of a single-chip integrated USB 2.0 transceiver, smart SIE, and enhanced 8051 microprocessor running at 48 MHz (nominal) that supports USB 2.0.

8.2.2.1.3 Bus Protocol

USB is a polled bus. The host controller (typically at PC) initiates all data transfers. Each transaction begins when the PC sends a packet. Communications are always through the bulk transfer mode, and 512 bytes of data are always written/read at a time. The packet consists of the following:

- Header (6 bytes)
- Data (505 bytes)
- Checksum (1 byte)

The USB device that is addressed selects itself by decoding the appropriate address fields. The direction of data transfer, either read or write, is specified in the packet header. The source of the transaction then sends a data packet or indicates it has no data to transfer. At the end of either a single packet transfer or a multi-packet transfer, the destination responds with a handshake packet indicating whether the transfer was successful.

The packet header consists of:

- CMD1 – Indicates if packet is write/write response or read/read response
- CMD2 – Groups major functions together
- CMD3 – Provides more information about packet grouping defined in CMD2

- CMD4 – Used to indicate location of data in a multi-packet transfer
- Len_MSB:Len_LSB – Valid number of bytes of data transferred in packet data

Header						Data	Checksum
CMD1 1 byte	CMD2 1 byte	CMD3 1 byte	CMD4 1 byte	Len_LSB 1 byte	Len_MSB 1 byte	0-505 bytes	1 byte

Figure 15. USB Data Packet

As discussed previously, the header describes whether the data transaction is to be a read or write and designates the data endpoint. The data portion of the packet carries the payload and is followed by a handshaking mechanism, checksum, that reports if the data was received successfully, or if the endpoint is stalled or not available to accept data.

Table 3. Recommended USB Devices

PART NUMBER	MANUFACTURER
CY7C68013A	Cypress
24LC128I/SN	Microchip Technology

8.2.2.1.4 SPI Slave Interface

The DLPC200 controller SPI interface consists of a 5-MHz input.

The SPI bus specifies five logic signals.

- SLAVE_SPI_CLK – Serial clock (output from master)
- SLAVE_SPI_MOSI – Master output, slave input (output from master)
- SLAVE_SPI_MISO – Master input, slave output (output from slave, does not tristate)
- $\overline{\text{SLAVE_SPI_CS}}$ – Slave select (active low; output from master)
- SLAVE_SPI_ACK – Holdoff signal to indicate that the slave is processing commands and cannot accept new input (output from slave)

The master pulls the slave-select low. During each SPI clock cycle, a full-duplex data transmission occurs:

- The master sends a bit on the MOSI line; the slave reads it from that same line.
- The slave sends a bit on the MISO line; the master reads it from that same line.

Transmissions involve two shift registers, one in the master and one in the slave; they are connected in a ring. Data is shifted out with the most significant bit first, while shifting a new least significant bit into the same register.

After that register has been shifted out, the master and slave have exchanged register values. If there is more data to exchange, the shift registers are loaded with new data and the process repeats. Transmissions may involve any number of clock cycles.

When there is no more data to be transmitted, the master stops toggling its clock. Transmissions consist of packet commands/responses similar to the protocol defined for the USB interface. The SPI slave supports variable-length command and response packets, and a master can initiate multiple such transmissions as needed.

NOTE

The SLAVE_SPI_MOSI signal does not tristate. To use the controller's slave SPI interface in a multi-slave SPI bus an external tristate buffer, like [SN74LVC1G](#), must be used on the SLAVE_SPI_MOSI signal.

8.2.2.1.5 Parallel Flash Memory Interface

The controller parallel flash memory interface supports a high-speed NOR device with a 16-bit data bus and up to 1 GB of memory.

To perform an asynchronous read, an address is driven onto the address bus, and \overline{CE} is asserted. \overline{WE} and \overline{RST} must already have been deasserted. WAIT is configured to be active low and is set to a deasserted state. \overline{ADV} must be held low throughout the read cycle. CLK is not used for asynchronous reads and is ignored. After \overline{OE} is asserted, the data is driven onto DQ[15:0] after an initial access time t_{AVQV} or t_{GLQV} delay.

The WAIT signal indicates data valid when the device is operating in asynchronous mode (RCR.15 = 0). The WAIT signal is only deasserted when data is valid on the bus. When the device is operating in asynchronous non-array read mode, such as read status, read ID, or read query, the WAIT signal is also deasserted when data is valid on the bus. WAIT behavior during asynchronous non-array reads at the end of the word line works correctly only on the first data access.

To perform a write operation, both \overline{CE} and \overline{WE} are asserted while \overline{RST} and \overline{OE} are deasserted. During a write operation, address and data are latched on the rising edge of \overline{WE} or \overline{CE} , whichever occurs first. When the device is operating in write operations, WAIT is set to a deasserted state as determined by RCR.10.

Table 4. Recommended Parallel Flash Devices

PART NUMBER	MANUFACTURER	SIZE
JS28F00AP30BF	Numonyx	128 Mb

8.2.2.1.6 Serial Flash Memory Interface

Table 5 shows the serial flash parts that were tested by TI and found to work properly with the DLPC200.

Table 5. Recommended Serial Flash Devices

PART NUMBER	MANUFACTURER	SIZE
M25P64	Numonyx	64 Mb
W25X64	Winbond	64 Mb

8.2.2.1.7 SRAM Interface

Table 6 shows the serial flash parts that were tested by TI and found to work properly with the DLPC200. See the recommended SRAM data sheet for read and write cycle timing information.

Table 6. Recommended Static RAM Devices

PART NUMBER	MANUFACTURER	SIZE
CY7C1011DV33	Cypress	2 Mb

8.2.2.1.8 DDR2 SDR Memory Interface

The DDR2 SDRAM is a high-speed CMOS, dynamic random-access memory. It is internally configured as a multibank DRAM. The controller DDR-2 memory interface consists of four 32-Mb by 16-bit wide, DDR-2 interfaces with double-data-rate signaling, operating at 133.33 MHz (nominal). A bidirectional data strobe (DQS, \overline{DQS}) is transmitted externally, along with data, for use in data capture at the receiver. DQS is a strobe transmitted by the DDR2 SDRAM during READ commands and by the memory controller during WRITE commands. DQS is edge-aligned with data for READ commands and center-aligned with data for WRITE commands.

The DDR2 SDRAM operates from a differential clock (CK and \overline{CK}); the crossing of CK going high and \overline{CK} going low is referred to as the positive edge of CK. Commands (address and control signals) are registered at every positive edge of CK. Input data is registered on both edges of DQS, and output data is referenced to both edges of DQS as well as to both edges of CK. Read and write accesses to the DDR2 SDRAM are burst-oriented; accesses start at a selected location and continue for a programmed number of locations in a programmed sequence.

Accesses begin with the registration of an ACTIVATE command, which is then followed by a READ or WRITE command. The address bits registered coincident with the ACTIVATE command are used to select the bank and row to be accessed. The address bits registered coincident with the READ or WRITE command are used to select the bank and the starting column location for the burst access.

8.2.2.1.9 Projector Image and Control Port Signals

The DLPC200 provides two input ports for graphics and motion video inputs. The following listed signals support the two input interface modes.

Following are the two input image interface modes, signal descriptions, and pins needed on the DLPC200.

- PORT 1, 28 pins (HDMI connector)
 - PORT1_D(23-0) – Projector data
 - PORT1_VSYNC – Vertical sync
 - PORT1_HSYNC – Horizontal sync
 - PORT1_IVALID – Data enable
 - PORT1_CLK – Projector clock (rising edge or falling edge, to capture input data)
- PORT 2, 28 pins (expansion connector)
 - PORT2_D(23-0) – Projector data
 - PORT2_VSYNC – Vertical sync
 - PORT2_HSYNC – Horizontal sync
 - PORT2_IVALID – Data enable
 - PORT2_CLK – Projector clock (rising edge or falling edge, to capture input data)

Two control interfaces, USB and SPI, are provided to configure the DLPC200, as well as to transmit pattern data to memory for structured light mode. Following are the pins needed for the SPI and USB control interfaces.

- USB, 48 MHz
 - USB_CLK – USB clock
 - USB_CTRL1 – FIFO full flag
 - USB_CTRL2 – FIFO empty flag
 - USB_FD(15-0) – USB data
 - USB_PA02 – FIFO output enable for reads
 - USB_PA04 – FIFO address bit
 - USB_PA05 – FIFO address bit
 - USB_RDY1 – Write enable
 - USB_RDY0 – Read enable
- SPI, 5 MHz
 - SLAVE_SPI_CLK – SPI clock
 - SLAVE_SPI_ACK – Busy signal that holds off additional transactions until the slave has completed processing data
 - SLAVE_SPI_MISO – Output from slave
 - SLAVE_SPI_MOSI – Output from master
 - SLAVE_SPI_CS – Slave select

Images are displayed via control of the DMD and DLPA200. The DLPC200 DMD interface consists of a 200-MHz (nominal) half-bus DDR output-only interface with LVDS signaling. The serial communications port (SCP), 125-kHz nominal, is used to read or write control data to both the DMD and the DLPA200. The following listed signals support data transfer to the DMD and DLPA200.

- DMD, 200 MHz
 - DMD_CLK_AP, DMD_CLK_AN – DMD clock for A
 - DMD_CLK_BP, DMD_CLK_BN – DMD clock for B
 - DMD_DAT_AP, DMD_DAT_AN(1, 3, 5, 7, 9, 11, 13, 15) – Data bus A (odd-numbered pins are used for half-bus)
 - DMD_DAT_BP, DMD_DAT_BN(1, 3, 5, 7, 9, 11, 13, 15) – Data bus B (odd-numbered pins are used for half-bus)
 - DMD_SCRTL_AP, DMD_SCRTL_AN – S-control for A
 - DMD_SCRTL_BP, DMD_SCRTL_BN – S-control for B
- DLPA200, 125 kHz

- SCP_DMD_RST_CLK – SCP clock
- SCP_DMD_EN – Enable DMD communication
- SCP_RST_EN – Enable DLPA200 communication
- SCP_DMD_RST_DI – Input data
- SCP_DMD_RST_DO – Output data

8.2.2.1.10 SDRAM Memory

The DLPC200 requires an external DDR2 SDR SDRAM. The DLPC200 supports the use of four 512-Mb SDRAMs. The requirements for the SDRAMs are:

- SDRAM type: DDR2
- Speed: 133 MHz minimum
- 16-bit interface size: 32 Mb
- Supply voltage: 1.8 V

Table 7 lists the recommended SDRAM devices that have been tested by TI and found to work properly with the DLPC200.

Table 7. Recommended SDRAM Devices

PART NUMBER	MANUFACTURER	SIZE
MT47H32M16-25E (replaces now obsolete – MT47H32M16R)	Micron	512 Mb

8.2.3 Application Curve

The DLPC200 is used to control the DLP5500 0.5-inch XGA DMD. This device can be used for numerous applications in the visible range of the spectrum such as 3D printing or structured light. Figure 16 shows single-pass window transmission for 0° and 30° angles of incidence. The area from 420 to 700 nm (light blue) is the range specified for operation of the DLP5500.

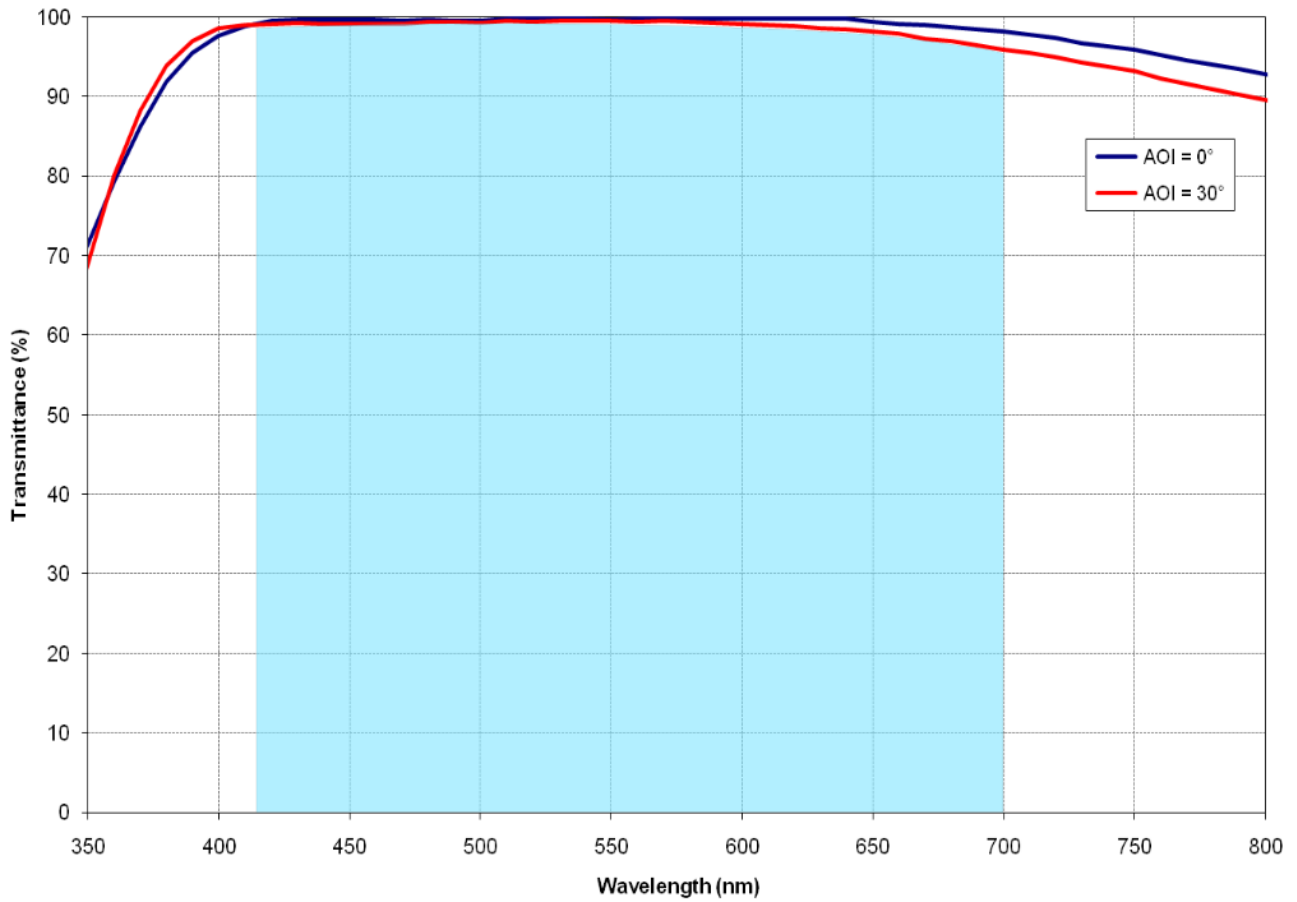

Figure 16. Window Transmission Curve for the DLP5500

9 Power Supply Recommendations

9.1 Power-Up Requirements

Details about the chip power-up requirements are included in the [DLPZ004](#) chipset data sheet. For the DLPC200, there is a 50-MHz reference clock that must meet the specifications listed in [Table 8](#). Additionally, at power-up, the 3.3-V supply must be stable for 2 s before the global reset (`RESET`) occurs, and then `PWR_GOOD` occurs within 20 ms.

The latest revision of the firmware (#DLPR200) does not enable the LEDs over the LED Control interface until initialization is complete and any solution loaded in flash is running.

Table 8. Reference Clock Oscillator Requirements

PART NUMBER	FREQUENCY STABILITY	FREQUENCY	SUPPLY VOLTAGE
ASV-50.000MHZ-E-J-T	±20 ppm (0.002% or ±0.001 MHz)	50 MHz	3.3 V

9.2 Power-Down Requirements

Details about the chip power-down requirements are included in the [DLPZ004](#) chipset data sheet. For the DLPC200, there is a minimum 1-ms delay from the time when `PWR_GOOD` goes low until any of the supplied voltages can drop below their minimum valid values (see [Table 9](#)). This is required so that the DMD can be parked. See [Table 9](#) for more details.

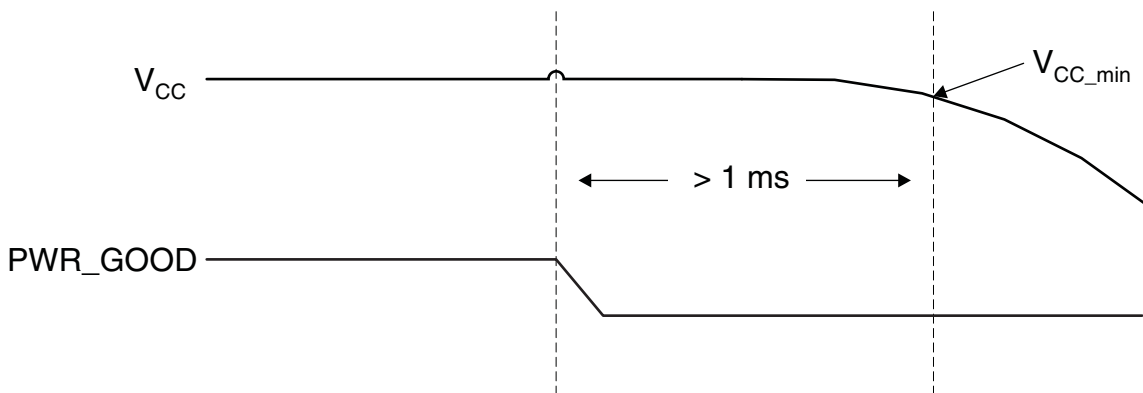

Figure 17.

Table 9. Supply Voltages and Minimum Values

V_{CC}	V_{CC_min}	UNIT
1.2	1.14	V
1.8	1.71	
2.5	2.375	
3.3	3.135	

10 Layout

10.1 Layout Guidelines

10.1.1 Impedance Requirements

Signals should be routed to have a matched impedance of $50\ \Omega \pm 10\%$ except for LVDS differential pairs (DMD_DAT_Xnn, DMD_DCKL_Xn, and DMD_SCTRL_Xn) and DDR2 differential clock pairs (MEM_CLK_nn), which should be matched to $100\ \Omega \pm 10\%$ across each pair.

10.1.2 PCB Signal Routing

When designing a PCB board for the DLPC200 the following are recommended:

Maintain signal trace corners no sharper than 45° . Adjacent signal layers should have the predominate traces routed orthogonal to each other. TI recommends that critical signals be hand routed in the following order: DDR2 Memory, DMD (LVDS signals), then DLPA200 signals.

TI does not recommend signal routing on power or ground planes.

TI does not recommend ground plane slots.

Do not allow high speed signal traces to cross over slots in adjacent power and/or ground planes.

Table 10. Important Signal Trace Constraints

Signal	Constraints
DDR2 differential clock pairs	P-to-N length <12 mils (0.31 mm) Trace width: 30 mil (0.76 mm)
DDR2 data	Length within ± 150 mils (3.81 mm) relative to DDR2 differential clock Maximum termination signal recommended trace length <0.5 inch (12.7 mm)
LVDS (DMD_DAT_xnn, DMD_DCKL_xn, and DMD_SCTRL_xn)	P-to-N data, clock, and SCTRL: <10 mils (0.25 mm); Pair-to-pair <10 mils (0.25 mm); Bundle-to-bundle <2000 mils (50 mm, for example DMD_DAT_Ann to DMD_DAT_Bnn) Trace width: 4 mil (0.1 mm) Trace spacing: In ball field – 4 mil (0.11 mm); PCB etch – 14 mil (0.36 mm) Maximum recommended trace length <6 inches (150 mm)

Table 11. Power Trace Widths and Spacing

Signal Name	Minimum Trace Width	Minimum Trace Spacing	Layout Requirements
GND	Maximize	5 mil (0.13 mm)	Maximize trace width to connecting pin as a minimum
P3P3V	400 mil (10.2 mm)	10 mil (0.25 mm)	Create mini plane and connect to devices as necessary with multiple vias
P5V, P2P5V, P1P8V, P1P5V, P1P2V	50 mil (1.3 mm)	10 mil (0.25 mm)	Create mini planes and connect to devices as necessary with multiple vias
P5V, P3P3V, P2P5V, P1P8V, P1P5V, P1P2V	30 mil (0.76 mm)	10 mil (0.25 mm)	Stub width to connecting IC pins; maximize width when possible
VREF_Bn	200 mil (5.1 mm)	30 mil (0.76 mm)	Stub width to connecting IC pins; maximize width when possible

10.1.3 Fiducials

For automatic component insertion fiducials, use 0.05-inch copper with a 0.1-inch cutout (antipad). Fiducials for optical auto insertion are placed on three corners of both sides of the PCB.

10.2 Layout Example

For LVDS (and other differential signal) pairs and groups, it is important to match trace lengths. In the area of the dashed lines, [Figure 18](#) shows correct matching of signal pair lengths with serpentine sections to maintain the correct impedance.

Layout Example (continued)

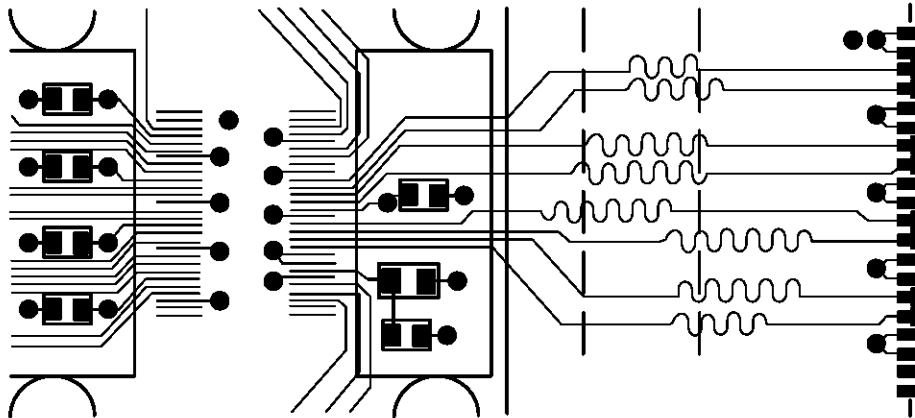

Figure 18. Mitering LVDS Traces to Match Lengths

10.3 Thermal Considerations

The underlying thermal limitation for the DLPC200 is that the maximum operating junction temperature (T_J) not be exceeded (see [Recommended Operating Conditions](#)). This temperature depends on operating ambient temperature, airflow, PCB design (including the component layout density and the amount of copper used), power dissipation of the DLPC200, and power dissipation of surrounding components. The DLPC200 package is designed primarily to extract heat through the power and ground planes of the PCB; thus, copper content and airflow over the PCB are important factors.

10.3.1 Heat Sink

A heat sink not required for operation between 0°C and 55°C ambient, but is required for operation between 55°C and 85°C, TI recommends a low-profile (15-mm) heat sink. See [Thermal Information](#) for thermal resistance with different airflow values without a heat sink.

11 器件和文档支持

11.1 器件支持

11.1.1 Third-Party Products Disclaimer

TI'S PUBLICATION OF INFORMATION REGARDING THIRD-PARTY PRODUCTS OR SERVICES DOES NOT CONSTITUTE AN ENDORSEMENT REGARDING THE SUITABILITY OF SUCH PRODUCTS OR SERVICES OR A WARRANTY, REPRESENTATION OR ENDORSEMENT OF SUCH PRODUCTS OR SERVICES, EITHER ALONE OR IN COMBINATION WITH ANY TI PRODUCT OR SERVICE.

11.1.2 器件标记

器件标记应如下所示。



标记关键字:

- 第 1 行: TI 参考号
- 第 2 行: 器件名称
- 第 3 行: DLP[®]徽标
- 第 4 行: 日期代码
- 第 5 行: 原产国/地区
- 第 6 行: 组装批次编号
- 第 7 行: 追踪代码

11.2 文档支持

相关文档:

- [DLP 0.55 XGA 芯片组数据表](#)
- [DLPA200 DMD 微镜驱动器](#)
- [DLP5500 0.55 XGA DMD 数据表](#)

11.3 接收文档更新通知

要接收文档更新通知, 请导航至 TI.com.cn 上的器件产品文件夹。单击右上角的 [通知我](#) 进行注册, 即可每周接收产品信息更改摘要。有关更改的详细信息, 请查看任何已修订文档中包含的修订历史记录。

11.4 社区资源

下列链接提供到 TI 社区资源的连接。链接的内容由各个分销商“按照原样”提供。这些内容并不构成 TI 技术规范, 并且不一定反映 TI 的观点; 请参阅 TI 的 [《使用条款》](#)。

TI E2E™ 在线社区 *TI 的工程师对工程师 (E2E) 社区*。此社区的创建目的在于促进工程师之间的协作。在 e2e.ti.com 中, 您可以咨询问题、分享知识、拓展思路并与同行工程师一道帮助解决问题。

社区资源 (接下页)

设计支持 *TI 参考设计支持* 可帮助您快速查找有帮助的 E2E 论坛、设计支持工具以及技术支持的联系信息。

11.5 商标

E2E is a trademark of Texas Instruments.

DLP is a registered trademark of Texas Instruments.

11.6 静电放电警告



这些装置包含有限的内置 ESD 保护。存储或装卸时，应将导线一起截短或将装置放置于导电泡棉中，以防止 MOS 门极遭受静电损伤。

11.7 Glossary

SLYZ022 — *TI Glossary*.

This glossary lists and explains terms, acronyms, and definitions.

12 机械、封装和可订购信息

以下页面包含机械、封装和可订购信息。这些信息是指定器件的最新可用数据。数据如有变更，恕不另行通知，且不会对此文档进行修订。如需获取此数据表的浏览器版本，请参阅左侧的导航栏。

PACKAGING INFORMATION

Orderable part number	Status (1)	Material type (2)	Package Pins	Package qty Carrier	RoHS (3)	Lead finish/ Ball material (4)	MSL rating/ Peak reflow (5)	Op temp (°C)	Part marking (6)
DLPC200ZEW	Active	Production	BGA (ZEW) 780	36 JEDEC TRAY (5+1)	Yes	Call TI	Level-3-260C-168 HR	-20 to 85	

(1) **Status:** For more details on status, see our [product life cycle](#).

(2) **Material type:** When designated, preproduction parts are prototypes/experimental devices, and are not yet approved or released for full production. Testing and final process, including without limitation quality assurance, reliability performance testing, and/or process qualification, may not yet be complete, and this item is subject to further changes or possible discontinuation. If available for ordering, purchases will be subject to an additional waiver at checkout, and are intended for early internal evaluation purposes only. These items are sold without warranties of any kind.

(3) **RoHS values:** Yes, No, RoHS Exempt. See the [TI RoHS Statement](#) for additional information and value definition.

(4) **Lead finish/Ball material:** Parts may have multiple material finish options. Finish options are separated by a vertical ruled line. Lead finish/Ball material values may wrap to two lines if the finish value exceeds the maximum column width.

(5) **MSL rating/Peak reflow:** The moisture sensitivity level ratings and peak solder (reflow) temperatures. In the event that a part has multiple moisture sensitivity ratings, only the lowest level per JEDEC standards is shown. Refer to the shipping label for the actual reflow temperature that will be used to mount the part to the printed circuit board.

(6) **Part marking:** There may be an additional marking, which relates to the logo, the lot trace code information, or the environmental category of the part.

Multiple part markings will be inside parentheses. Only one part marking contained in parentheses and separated by a "-" will appear on a part. If a line is indented then it is a continuation of the previous line and the two combined represent the entire part marking for that device.

Important Information and Disclaimer: The information provided on this page represents TI's knowledge and belief as of the date that it is provided. TI bases its knowledge and belief on information provided by third parties, and makes no representation or warranty as to the accuracy of such information. Efforts are underway to better integrate information from third parties. TI has taken and continues to take reasonable steps to provide representative and accurate information but may not have conducted destructive testing or chemical analysis on incoming materials and chemicals. TI and TI suppliers consider certain information to be proprietary, and thus CAS numbers and other limited information may not be available for release.

In no event shall TI's liability arising out of such information exceed the total purchase price of the TI part(s) at issue in this document sold by TI to Customer on an annual basis.

ZEW (S-PBGA-N780)

PLASTIC BALL GRID ARRAY

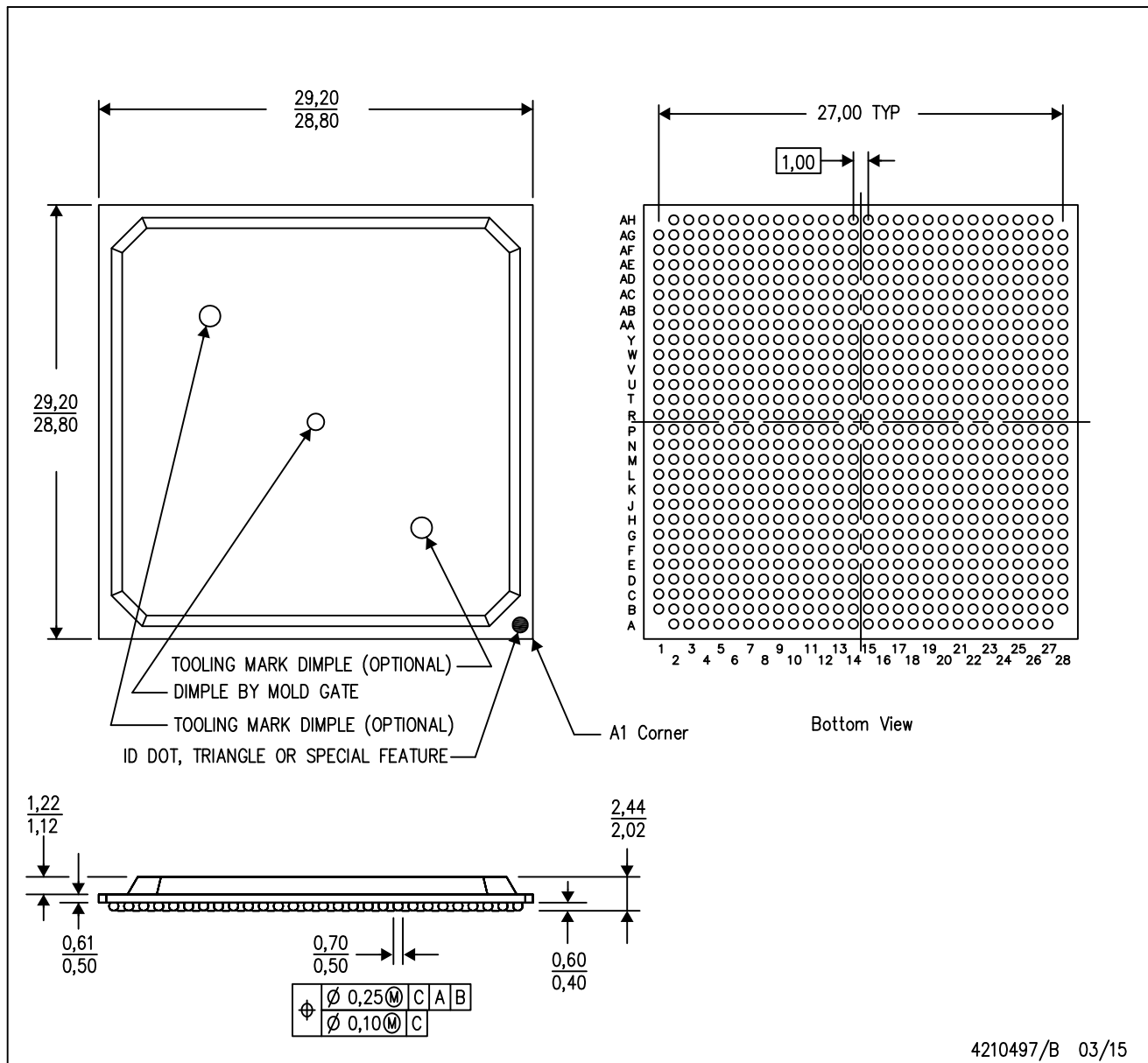

4210497/B 03/15

- NOTES:
- A. All linear dimensions are in millimeters. Dimensioning and tolerancing per ASME Y14.5M-1994.
 - B. This drawing is subject to change without notice.
 - C. Falls within JEDEC MS-034, Variation: AAM-1.
 - D. This package is Pb-free.

重要通知和免责声明

TI“按原样”提供技术和可靠性数据（包括数据表）、设计资源（包括参考设计）、应用或其他设计建议、网络工具、安全信息和其他资源，不保证没有瑕疵且不做任何明示或暗示的担保，包括但不限于对适销性、与某特定用途的适用性或不侵犯任何第三方知识产权的暗示担保。

这些资源可供使用 TI 产品进行设计的熟练开发人员使用。您将自行承担以下全部责任：(1) 针对您的应用选择合适的 TI 产品，(2) 设计、验证并测试您的应用，(3) 确保您的应用满足相应标准以及任何其他安全、安保法规或其他要求。

这些资源如有变更，恕不另行通知。TI 授权您仅可将这些资源用于研发本资源所述的 TI 产品的相关应用。严禁以其他方式对这些资源进行复制或展示。您无权使用任何其他 TI 知识产权或任何第三方知识产权。对于因您对这些资源的使用而对 TI 及其代表造成的任何索赔、损害、成本、损失和债务，您将全额赔偿，TI 对此概不负责。

TI 提供的产品受 [TI 销售条款](#)、[TI 通用质量指南](#) 或 [ti.com](#) 上其他适用条款或 TI 产品随附的其他适用条款的约束。TI 提供这些资源并不会扩展或以其他方式更改 TI 针对 TI 产品发布的适用的担保或担保免责声明。除非德州仪器 (TI) 明确将某产品指定为定制产品或客户特定产品，否则其产品均为按确定价格收入目录的标准通用器件。

TI 反对并拒绝您可能提出的任何其他或不同的条款。

版权所有 © 2026，德州仪器 (TI) 公司

最后更新日期：2025 年 10 月