

### Features

- Synchronous Counting and Asynchronous Loading
- Two Outputs for N-Bit Cascading
- Look-Ahead Carry for High-Speed Counting
- Fanout (Over Temperature Range)
  - Standard Outputs . . . . . 10 LSTTL Loads
  - Bus Driver Outputs . . . . . 15 LSTTL Loads
- Wide Operating Temperature Range . . . -55°C to 125°C
- Balanced Propagation Delay and Transition Times
- Significant Power Reduction Compared to LSTTL Logic ICs
- HC Types
  - 2V to 6V Operation
  - High Noise Immunity:  $N_{IL} = 30\%$ ,  $N_{IH} = 30\%$  of  $V_{CC}$  at  $V_{CC} = 5V$
- HCT Types
  - 4.5V to 5.5V Operation
  - Direct LSTTL Input Logic Compatibility,  $V_{IL} = 0.8V$  (Max),  $V_{IH} = 2V$  (Min)
  - CMOS Input Compatibility,  $I_I \leq 1\mu A$  at  $V_{OL}$ ,  $V_{OH}$

### Description

The 'HC192, 'HC193 and 'HCT193 are asynchronously presettable BCD Decade and Binary Up/Down synchronous counters, respectively.

### Pinout

CD54HC192, CD54HC193, CD54HCT193 (CERDIP)  
 CD74HC192 (PDIP, SOP, TSSOP)  
 CD74HC193 (PDIP, SOIC)  
 CD74HCT193 (PDIP)  
 TOP VIEW

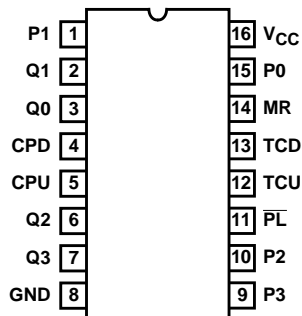

Presetting the counter to the number on the preset data inputs (P0-P3) is accomplished by a LOW asynchronous parallel load input ( $\overline{PL}$ ). The counter is incremented on the low-to-high transition of the Clock-Up input (and a high level on the Clock-Down input) and decremented on the low to high transition of the Clock-Down input (and a high level on the Clock-up input). A high level on the MR input overrides any other input to clear the counter to its zero state. The Terminal Count up (carry) goes low half a clock period before the zero count is reached and returns to a high level at the zero count. The Terminal Count Down (borrow) in the count down mode likewise goes low half a clock period before the maximum count (9 in the 192 and 15 in the 193) and returns to high at the maximum count. Cascading is effected by connecting the carry and borrow outputs of a less significant counter to the Clock-Up and Clock-Down inputs, respectively, of the next most significant counter.

If a decade counter is preset to an illegal state or assumes an illegal state when power is applied, it will return to the normal sequence in one count as shown in state diagram.

### Ordering Information

PART NUMBER	TEMP. RANGE (°C)	PACKAGE
CD54HC192F3A	-55 to 125	16 Ld CERDIP
CD54HC193F3A	-55 to 125	16 Ld CERDIP
CD54HCT193F3A	-55 to 125	16 Ld CERDIP
CD74HC192E	-55 to 125	16 Ld PDIP
CD74HC192NSR	-55 to 125	16 Ld SOP
CD74HC192PW	-55 to 125	16 Ld TSSOP
CD74HC192PWR	-55 to 125	16 Ld TSSOP
CD74HC192PWT	-55 to 125	16 Ld TSSOP
CD74HC193E	-55 to 125	16 Ld PDIP
CD74HC193M	-55 to 125	16 Ld SOIC
CD74HC193MT	-55 to 125	16 Ld SOIC
CD74HC193M96	-55 to 125	16 Ld SOIC
CD74HCT193E	-55 to 125	16 Ld PDIP

NOTE: When ordering, use the entire part number. The suffixes 96 and R denote tape and reel. The suffix T denotes a small-quantity reel of 250.

**Functional Diagram**

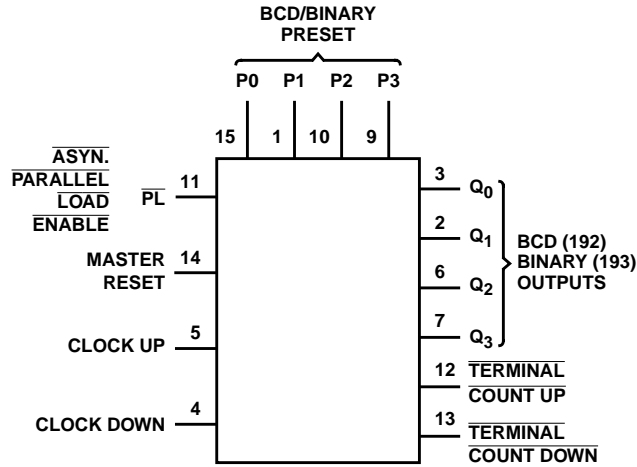

**TRUTH TABLE**

CLOCK UP	CLOCK DOWN	RESET	PARALLEL LOAD	FUNCTION
↑	H	L	H	Count Up
H	↑	L	H	Count Down
X	X	H	X	Reset
X	X	L	L	Load Preset Inputs

H = High Voltage Level, L = Low Voltage Level, X = Don't Care, ↑ = Transition from Low to High Level

## CD54/74HC192, CD54/74HC193, CD54/74HCT193

### Absolute Maximum Ratings

DC Supply Voltage, $V_{CC}$ .....	-0.5V to 7V
DC Input Diode Current, $I_{IK}$	
For $V_I < -0.5V$ or $V_I > V_{CC} + 0.5V$ .....	$\pm 20mA$
DC Output Diode Current, $I_{OK}$	
For $V_O < -0.5V$ or $V_O > V_{CC} + 0.5V$ .....	$\pm 20mA$
DC Output Source or Sink Current per Output Pin, $I_O$	
For $V_O > -0.5V$ or $V_O < V_{CC} + 0.5V$ .....	$\pm 25mA$
DC $V_{CC}$ or Ground Current, $I_{CC}$ or $I_{GND}$ .....	$\pm 50mA$

### Thermal Information

Package Thermal Impedance, $\theta_{JA}$ (see Note 1):	
E (PDIP) Package .....	67°C/W
M (SOIC) Package .....	73°C/W
NS (SOP) Package .....	64°C/W
PW (TSSOP) Package .....	108°C/W
Maximum Junction Temperature .....	150°C
Maximum Storage Temperature Range .....	-65°C to 150°C
Maximum Lead Temperature (Soldering 10s) .....	300°C
(SOIC - Lead Tips Only)	

### Operating Conditions

Temperature Range ( $T_A$ ) .....	-55°C to 125°C
Supply Voltage Range, $V_{CC}$	
HC Types .....	.2V to 6V
HCT Types .....	4.5V to 5.5V
DC Input or Output Voltage, $V_I, V_O$ .....	0V to $V_{CC}$
Input Rise and Fall Time	
2V .....	1000ns (Max)
4.5V .....	500ns (Max)
6V .....	400ns (Max)

*CAUTION: Stresses above those listed in "Absolute Maximum Ratings" may cause permanent damage to the device. This is a stress only rating and operation of the device at these or any other conditions above those indicated in the operational sections of this specification is not implied.*

#### NOTE:

- The package thermal impedance is calculated in accordance with JESD 51-7.

### DC Electrical Specifications

PARAMETER	SYMBOL	TEST CONDITIONS			25°C			-40°C TO 85°C		-55°C TO 125°C		UNITS
		$V_I$ (V)	$I_O$ (mA)	$V_{CC}$ (V)	MIN	TYP	MAX	MIN	MAX	MIN	MAX	
<b>HC TYPES</b>												
High Level Input Voltage	$V_{IH}$	-	-	2	1.5	-	-	1.5	-	1.5	-	V
				4.5	3.15	-	-	3.15	-	3.15	-	V
				6	4.2	-	-	4.2	-	4.2	-	V
Low Level Input Voltage	$V_{IL}$	-	-	2	-	-	0.5	-	0.5	-	0.5	V
				4.5	-	-	1.35	-	1.35	-	1.35	V
				6	-	-	1.8	-	1.8	-	1.8	V
High Level Output Voltage CMOS Loads	$V_{OH}$	$V_{IH}$ or $V_{IL}$	-0.02	2	1.9	-	-	1.9	-	1.9	-	V
			-0.02	4.5	4.4	-	-	4.4	-	4.4	-	V
High Level Output Voltage TTL Loads	$V_{OH}$	$V_{IH}$ or $V_{IL}$	-0.02	6	5.9	-	-	5.9	-	5.9	-	V
			-4	4.5	3.98	-	-	3.84	-	3.7	-	V
Low Level Output Voltage CMOS Loads	$V_{OL}$	$V_{IH}$ or $V_{IL}$	0.02	2	-	-	0.1	-	0.1	-	0.1	V
			0.02	4.5	-	-	0.1	-	0.1	-	0.1	V
Low Level Output Voltage TTL Loads	$V_{OL}$	$V_{IH}$ or $V_{IL}$	0.02	6	-	-	0.1	-	0.1	-	0.1	V
			4	4.5	-	-	0.26	-	0.33	-	0.4	V
Input Leakage Current	$I_I$	$V_{CC}$ or GND	0	6	-	-	0.26	-	0.33	-	0.4	V
			5.2	6	-	-	0.26	-	0.33	-	0.4	V
Input Leakage Current	$I_I$	$V_{CC}$ or GND	-	6	-	-	$\pm 0.1$	-	$\pm 1$	-	$\pm 1$	$\mu A$
Quiescent Device Current	$I_{CC}$	$V_{CC}$ or GND	0	6	-	-	8	-	80	-	160	$\mu A$

**CD54/74HC192, CD54/74HC193, CD54/74HCT193**

**DC Electrical Specifications (Continued)**

PARAMETER	SYMBOL	TEST CONDITIONS			25°C			-40°C TO 85°C		-55°C TO 125°C		UNITS
		V <sub>I</sub> (V)	I <sub>O</sub> (mA)	V <sub>CC</sub> (V)	MIN	TYP	MAX	MIN	MAX	MIN	MAX	
<b>HCT TYPES</b>												
High Level Input Voltage	V <sub>IH</sub>	-	-	4.5 to 5.5	2	-	-	2	-	2	-	V
Low Level Input Voltage	V <sub>IL</sub>	-	-	4.5 to 5.5	-	-	0.8	-	0.8	-	0.8	V
High Level Output Voltage CMOS Loads	V <sub>OH</sub>	V <sub>IH</sub> or V <sub>IL</sub>	-0.02	4.5	4.4	-	-	4.4	-	4.4	-	V
High Level Output Voltage TTL Loads			-4	4.5	3.98	-	-	3.84	-	3.7	-	V
Low Level Output Voltage CMOS Loads	V <sub>OL</sub>	V <sub>IH</sub> or V <sub>IL</sub>	0.02	4.5	-	-	0.1	-	0.1	-	0.1	V
Low Level Output Voltage TTL Loads			4	4.5	-	-	0.26	-	0.33	-	0.4	V
Input Leakage Current	I <sub>I</sub>	V <sub>CC</sub> to GND	-	5.5	-	-	±0.1	-	±1	-	±1	μA
Quiescent Device Current	I <sub>CC</sub>	V <sub>CC</sub> or GND	-	5.5	-	-	8	-	80	-	160	μA
Additional Quiescent Device Current Per Input Pin: 1 Unit Load	ΔI <sub>CC</sub> (Note 2)	V <sub>CC</sub> - 2.1	-	4.5 to 5.5	-	100	360	-	450	-	490	μA

NOTE:

- For dual-supply systems theoretical worst case (V<sub>I</sub> = 2.4V, V<sub>CC</sub> = 5.5V) specification is 1.8mA.

**HCT Input Loading Table**

INPUT	UNIT LOADS
P0-P3	0.4
MR	1.45
PL	0.85
CPU, CPD	1.45

NOTE: Unit Load is ΔI<sub>CC</sub> limit specified in DC Electrical Specifications table, e.g. 360μA max at 25°C.

**CD54/74HC192, CD54/74HC193, CD54/74HCT193**

**Prerequisite For Switching Specifications**

PARAMETER	SYMBOL	V <sub>CC</sub> (V)	25°C			-40°C TO 85°C		-55°C TO 125°C		UNITS
			MIN	TYP	MAX	MIN	MAX	MIN	MAX	
<b>HC TYPES</b>										
Pulse Width CPU, CPD  192	t <sub>W</sub>	2	115	-	-	145	-	175	-	ns
		4.5	23	-	-	29	-	35	-	ns
		6	20	-	-	25	-	30	-	ns
CPU, CPD  193	t <sub>W</sub>	2	100	-	-	125	-	150	-	ns
		4.5	20	-	-	25	-	30	-	ns
		6	17	-	-	21	-	26	-	ns
$\overline{PL}$	t <sub>W</sub>	2	80	-	-	100	-	120	-	ns
		4.5	16	-	-	20	-	24	-	ns
		6	14	-	-	17	-	20	-	ns
MR	t <sub>W</sub>	2	100	-	-	125	-	150	-	ns
		4.5	20	-	-	25	-	30	-	ns
		6	17	-	-	21	-	26	-	ns
Set-up Time Pn to $\overline{PL}$	t <sub>SU</sub>	2	80	-	-	100	-	120	-	ns
		4.5	16	-	-	20	-	24	-	ns
		6	14	-	-	17	-	20	-	ns
Hold Time Pn to $\overline{PL}$	t <sub>H</sub>	2	0	-	-	0	-	0	-	ns
		4.5	0	-	-	0	-	0	-	ns
		6	0	-	-	0	-	0	-	ns
Hold Time CPD to CPU or CPU to CPD	t <sub>H</sub>	2	80	-	-	100	-	120	-	ns
		4.5	16	-	-	20	-	24	-	ns
		6	14	-	-	17	-	20	-	ns
Recovery Time $\overline{PL}$ to CPU, CPD	t <sub>REC</sub>	2	80	-	-	100	-	120	-	ns
		4.5	16	-	-	20	-	24	-	ns
		6	14	-	-	17	-	20	-	ns
MR to CPU, CPD	t <sub>REC</sub>	2	5	-	-	5	-	5	-	ns
		4.5	5	-	-	5	-	5	-	ns
		6	5	-	-	5	-	5	-	ns
Maximum Frequency CPU, CPD  192	f <sub>MAX</sub>	2	5	-	-	4	-	3	-	MHz
		4.5	22	-	-	18	-	15	-	MHz
		6	24	-	-	21	-	18	-	MHz
CPU, CPD  193	f <sub>MAX</sub>	2	5	-	-	4	-	3	-	MHz
		4.5	25	-	-	20	-	17	-	MHz
		6	29	-	-	24	-	20	-	MHz
<b>HCT TYPES</b>										
Pulse Width CPU, CPD  192	t <sub>W</sub>	2	-	-	-	-	-	-	-	ns
		4.5	23	-	-	29	-	35	-	ns
		6	-	-	-	-	-	-	-	ns
CPU, CPD  193	t <sub>W</sub>	2	-	-	-	-	-	-	-	ns
		4.5	23	-	-	29	-	35	-	ns
		6	-	-	-	-	-	-	-	ns

**CD54/74HC192, CD54/74HC193, CD54/74HCT193**

**Prerequisite For Switching Specifications (Continued)**

PARAMETER	SYMBOL	V <sub>CC</sub> (V)	25°C			-40°C TO 85°C		-55°C TO 125°C		UNITS
			MIN	TYP	MAX	MIN	MAX	MIN	MAX	
$\overline{PL}$	t <sub>W</sub>	2	-	-	-	-	-	-	-	ns
		4.5	16	-	-	20	-	24	-	ns
		6	-	-	-	-	-	-	-	ns
MR	t <sub>W</sub>	2	-	-	-	-	-	-	-	ns
		4.5	20	-	-	25	-	30	-	ns
		6	-	-	-	-	-	-	-	ns
Set-up Time P <sub>n</sub> to $\overline{PL}$	t <sub>SU</sub>	2	-	-	-	-	-	-	-	ns
		4.5	15	-	-	19	-	22	-	ns
		6	-	-	-	-	-	-	-	ns
Hold Time P <sub>n</sub> to $\overline{PL}$	t <sub>H</sub>	2	-	-	-	-	-	-	-	ns
		4.5	0	-	-	0	-	0	-	ns
		6	-	-	-	-	-	-	-	ns
Hold Time CPD to CPU or CPU to CPD	t <sub>H</sub>	2	-	-	-	-	-	-	-	ns
		4.5	16	-	-	20	-	24	-	ns
		6	-	-	-	-	-	-	-	ns
Recovery Time $\overline{PL}$ to CPU, CPD	t <sub>REC</sub>	2	-	-	-	-	-	-	-	ns
		4.5	15	-	-	19	-	22	-	ns
		6	-	-	-	-	-	-	-	ns
MR to CPU, CPD	t <sub>REC</sub>	2	-	-	-	-	-	-	-	ns
		4.5	5	-	-	5	-	5	-	ns
		6	-	-	-	-	-	-	-	ns
Maximum Frequency CPU, CPD 192	f <sub>MAX</sub>	2	-	-	-	-	-	-	-	MHz
		4.5	22	-	-	18	-	15	-	MHz
		6	-	-	-	-	-	-	-	MHz
CPU, CPD 193	f <sub>MAX</sub>	2	-	-	-	-	-	-	-	MHz
		4.5	22	-	-	18	-	15	-	MHz
		6	-	-	-	-	-	-	-	MHz

**Switching Specifications** Input t<sub>r</sub>, t<sub>f</sub> = 6ns

PARAMETER	SYMBOL	TEST CONDITIONS	V <sub>CC</sub> (V)	25°C			-40°C TO 85°C		-55°C TO 125°C		UNITS
				MIN	TYP	MAX	MIN	MAX	MIN	MAX	
<b>HC TYPES</b>											
Propagation Delay CPU to $\overline{TCU}$	t <sub>PLH</sub> , t <sub>PHL</sub>	C <sub>L</sub> = 50pF	2	-	-	125	-	155	-	190	ns
		C <sub>L</sub> = 50pF	4.5	-	-	25	-	31	-	38	ns
		C <sub>L</sub> = 15pF	5	-	10	-	-	-	-	-	ns
		C <sub>L</sub> = 50pF	6	-	-	21	-	26	-	32	ns
CPD to $\overline{TCU}$	t <sub>PLH</sub> , t <sub>PHL</sub>	C <sub>L</sub> = 50pF	2	-	-	125	-	155	-	190	ns
		C <sub>L</sub> = 50pF	4.5	-	-	25	-	31	-	38	ns
		C <sub>L</sub> = 15pF	5	-	10	-	-	-	-	-	ns
		C <sub>L</sub> = 50pF	6	-	-	21	-	26	-	32	ns
CPU to Q <sub>n</sub>	t <sub>PLH</sub> , t <sub>PHL</sub>	C <sub>L</sub> = 50pF	2	-	-	220	-	270	-	325	ns
		C <sub>L</sub> = 50pF	4.5	-	-	43	-	54	-	65	ns
		C <sub>L</sub> = 15pF	5	-	18	-	-	-	-	-	ns
		C <sub>L</sub> = 50pF	6	-	-	37	-	46	-	55	ns

**CD54/74HC192, CD54/74HC193, CD54/74HCT193**

**Switching Specifications** Input  $t_r, t_f = 6\text{ns}$  (Continued)

PARAMETER	SYMBOL	TEST CONDITIONS	V <sub>CC</sub> (V)	25°C			-40°C TO 85°C		-55°C TO 125°C		UNITS
				MIN	TYP	MAX	MIN	MAX	MIN	MAX	
CPD to Q <sub>n</sub>	t <sub>PLH</sub> , t <sub>PHL</sub>	C <sub>L</sub> = 50pF	2	-	-	220	-	270	-	325	ns
		C <sub>L</sub> = 50pF	4.5	-	-	43	-	54	-	65	ns
		C <sub>L</sub> = 15pF	5	-	18	-	-	-	-	-	ns
		C <sub>L</sub> = 50pF	6	-	-	37	-	46	-	55	ns
P <sub>L</sub> to Q <sub>n</sub>	t <sub>PLH</sub> , t <sub>PHL</sub>	C <sub>L</sub> = 50pF	2	-	-	220	-	275	-	330	ns
		C <sub>L</sub> = 50pF	4.5	-	-	44	-	55	-	66	ns
		C <sub>L</sub> = 15pF	5	-	18	-	-	-	-	-	ns
		C <sub>L</sub> = 50pF	6	-	-	37	-	47	-	56	ns
MR to Q <sub>n</sub>	t <sub>PHL</sub>	C <sub>L</sub> = 50pF	2	-	-	200	-	250	-	300	ns
		C <sub>L</sub> = 50pF	4.5	-	-	40	-	50	-	60	ns
		C <sub>L</sub> = 15pF	5	-	17	-	-	-	-	-	ns
		C <sub>L</sub> = 50pF	6	-	-	34	-	43	-	51	ns
Transition Time Q, TCU, TCD	t <sub>TLH</sub> , t <sub>THL</sub>	C <sub>L</sub> = 50pF	2	-	-	75	-	95	-	110	ns
			4.5	-	-	15	-	19	-	22	ns
			6	-	-	13	-	16	-	19	ns
Input Capacitance	C <sub>IN</sub>	C <sub>L</sub> = 50pF	-	-	-	10	-	10	-	10	pF
Power Dissipation Capacitance (Notes 3, 4)	C <sub>PD</sub>	C <sub>L</sub> = 15pF	5	-	40	-	-	-	-	-	pF
<b>HCT TYPES</b>											
Propagation Delay CPU to TCU	t <sub>PLH</sub> , t <sub>PHL</sub>	C <sub>L</sub> = 50pF	4.5	-	-	27	-	34	-	41	ns
		C <sub>L</sub> = 15pF	5	-	11	-	-	-	-	-	ns
CPU to TCD	t <sub>PLH</sub> , t <sub>PHL</sub>	C <sub>L</sub> = 50pF	4.5	-	-	27	-	34	-	41	ns
		C <sub>L</sub> = 15pF	5	-	11	-	-	-	-	-	ns
CPU to Q <sub>n</sub>	t <sub>PLH</sub> , t <sub>PHL</sub>	C <sub>L</sub> = 50pF	4.5	-	-	40	-	50	-	60	ns
		C <sub>L</sub> = 15pF	5	-	17	-	-	-	-	-	ns
CPD to Q <sub>n</sub>	t <sub>PLH</sub> , t <sub>PHL</sub>	C <sub>L</sub> = 50pF	4.5	-	-	40	-	50	-	60	ns
		C <sub>L</sub> = 15pF	5	-	17	-	-	-	-	-	ns
P <sub>L</sub> to Q <sub>n</sub>	t <sub>PLH</sub> , t <sub>PHL</sub>	C <sub>L</sub> = 50pF	4.5	-	-	46	-	58	-	69	ns
		C <sub>L</sub> = 15pF	5	-	21	-	-	-	-	-	ns
MR to Q <sub>n</sub>	t <sub>PHL</sub>	C <sub>L</sub> = 50pF	4.5	-	-	43	-	54	-	65	ns
		C <sub>L</sub> = 15pF	5	-	18	-	-	-	-	-	ns
Transition Time Q, TCU, TCD	t <sub>TLH</sub> , t <sub>THL</sub>	C <sub>L</sub> = 50pF	2	-	-	75	-	95	-	110	ns
			4.5	-	-	15	-	19	-	22	ns
Input Capacitance	C <sub>IN</sub>	C <sub>L</sub> = 50pF	-	-	-	10	-	10	-	10	pF
Power Dissipation Capacitance (Notes 3, 4)	C <sub>PD</sub>	C <sub>L</sub> = 15pF	5	-	50	-	-	-	-	-	pF

**NOTES:**

- C<sub>PD</sub> is used to determine the dynamic power consumption, per gate.
- $P_D = V_{CC}^2 f_i + \sum (C_L V_{CC}^2)$  where  $f_i$  = Input Frequency,  $C_L$  = Output Load Capacitance,  $V_{CC}$  = Supply Voltage.

**Test Circuits and Waveforms**

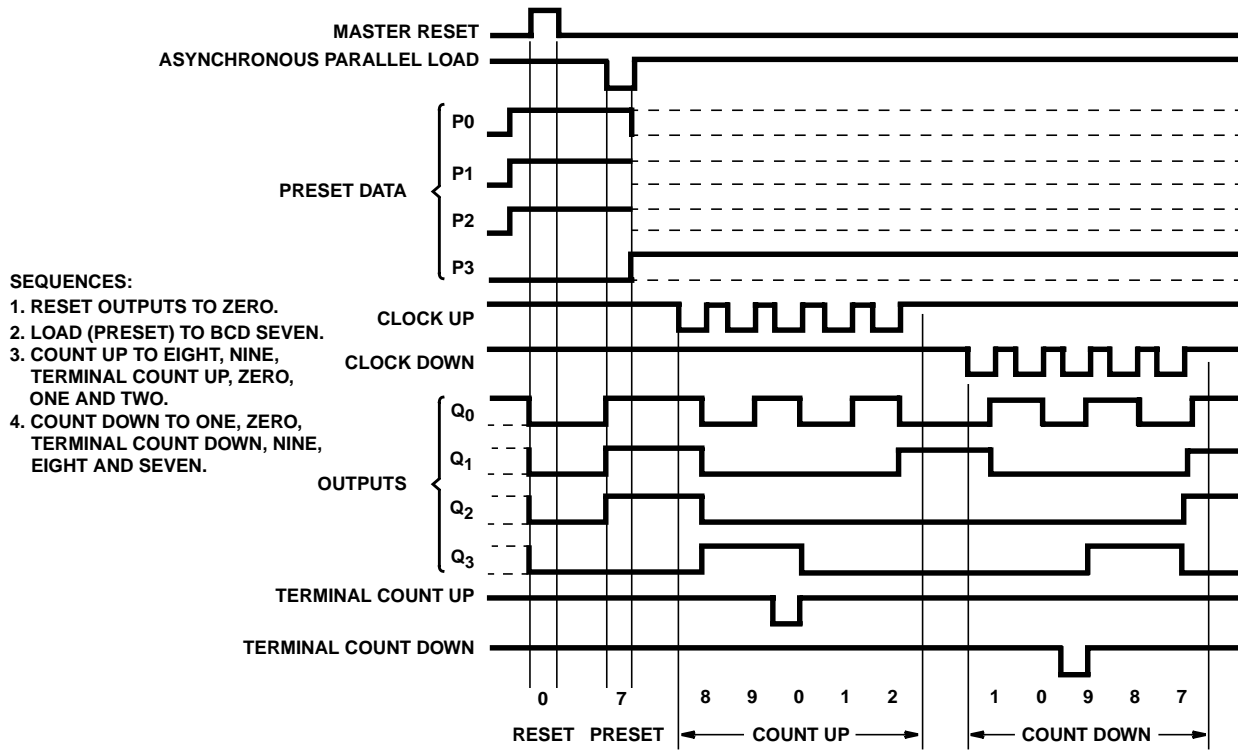

FIGURE 1. 'HC192 SYNCHRONOUS DECADE COUNTERS, TYPICAL RESET, PRESET AND COUNT SEQUENCES

Test Circuits and Waveforms (Continued)

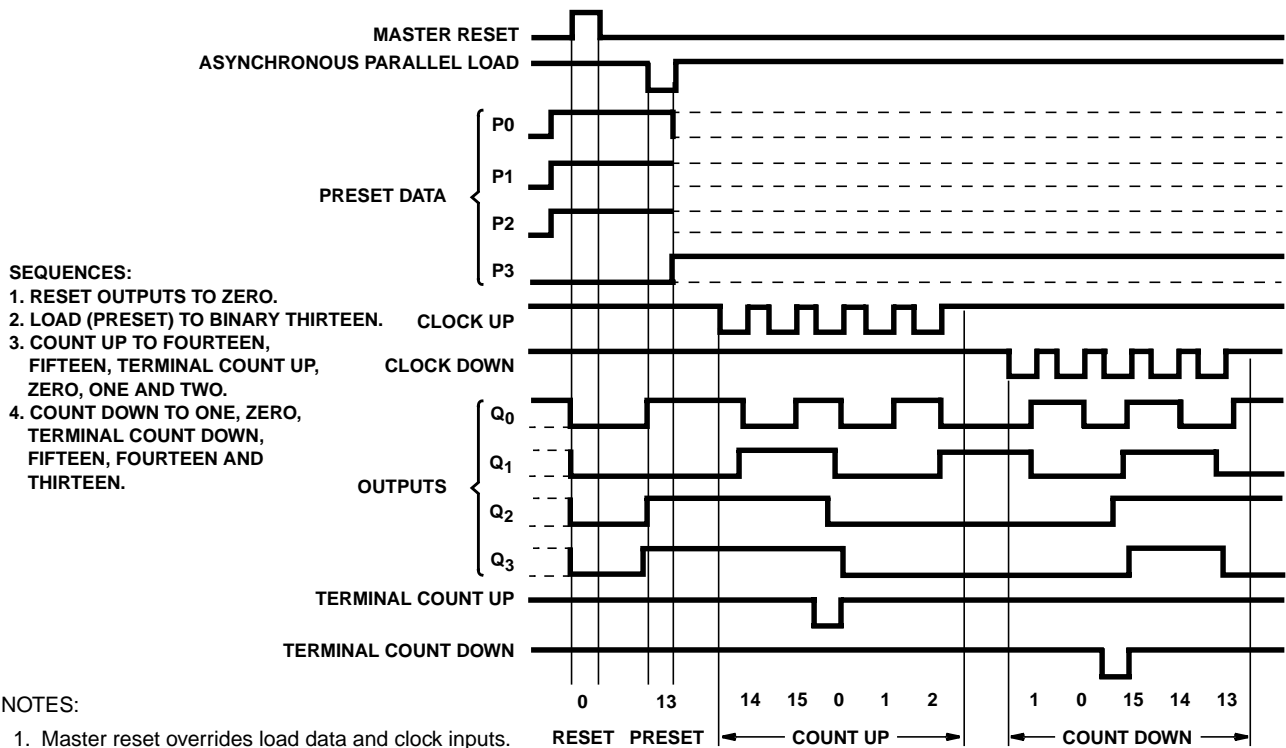

FIGURE 2. 'HC193 SYNCHRONOUS BINARY COUNTERS, TYPICAL RESET, PRESET AND COUNT SEQUENCES

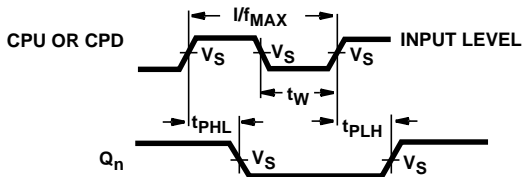

FIGURE 3. CLOCK TO OUTPUT DELAYS AND CLOCK PULSE WIDTH

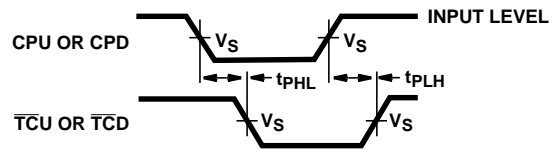

FIGURE 4. CLOCK TO TERMINAL COUNT DELAYS

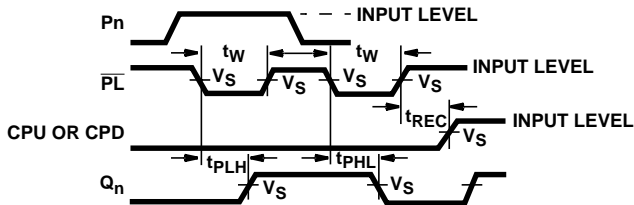

FIGURE 5. PARALLEL LOAD PULSE WIDTH, PARALLEL LOAD TO OUTPUT DELAYS, AND PARALLEL LOAD TO CLOCK RECOVERY TIME

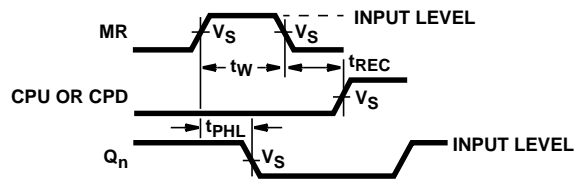

FIGURE 6. MASTER RESET PULSE WIDTH, MASTER RESET TO OUTPUT DELAY AND MASTER RESET TO CLOCK RECOVERY TIME



**PACKAGING INFORMATION**

Orderable part number	Status (1)	Material type (2)	Package   Pins	Package qty   Carrier	RoHS (3)	Lead finish/ Ball material (4)	MSL rating/ Peak reflow (5)	Op temp (°C)	Part marking (6)
<a href="#">5962-8780801EA</a>	Active	Production	CDIP (J)   16	25   TUBE	No	SNPB	N/A for Pkg Type	-55 to 125	5962-8780801EA CD54HC192F3A
<a href="#">5962-9084801MEA</a>	Active	Production	CDIP (J)   16	25   TUBE	No	SNPB	N/A for Pkg Type	-55 to 125	5962-9084801ME A CD54HCT193F3A
<a href="#">CD54HC192F3A</a>	Active	Production	CDIP (J)   16	25   TUBE	No	SNPB	N/A for Pkg Type	-55 to 125	5962-8780801EA CD54HC192F3A
CD54HC192F3A.A	Active	Production	CDIP (J)   16	25   TUBE	No	SNPB	N/A for Pkg Type	-55 to 125	5962-8780801EA CD54HC192F3A
<a href="#">CD54HC193F3A</a>	Active	Production	CDIP (J)   16	25   TUBE	No	SNPB	N/A for Pkg Type	-55 to 125	5962-8772401EA CD54HC193F3A
CD54HC193F3A.A	Active	Production	CDIP (J)   16	25   TUBE	No	SNPB	N/A for Pkg Type	-55 to 125	5962-8772401EA CD54HC193F3A
<a href="#">CD54HCT193F3A</a>	Active	Production	CDIP (J)   16	25   TUBE	No	SNPB	N/A for Pkg Type	-55 to 125	5962-9084801ME A CD54HCT193F3A
CD54HCT193F3A.A	Active	Production	CDIP (J)   16	25   TUBE	No	SNPB	N/A for Pkg Type	-55 to 125	5962-9084801ME A CD54HCT193F3A
<a href="#">CD74HC192E</a>	Active	Production	PDIP (N)   16	25   TUBE	Yes	NIPDAU	N/A for Pkg Type	-55 to 125	CD74HC192E
CD74HC192E.A	Active	Production	PDIP (N)   16	25   TUBE	Yes	NIPDAU	N/A for Pkg Type	-55 to 125	CD74HC192E
<a href="#">CD74HC192NSR</a>	Active	Production	SOP (NS)   16	2000   LARGE T&R	Yes	NIPDAU	Level-1-260C-UNLIM	-55 to 125	HC192M
CD74HC192NSR.A	Active	Production	SOP (NS)   16	2000   LARGE T&R	Yes	NIPDAU	Level-1-260C-UNLIM	-55 to 125	HC192M
CD74HC192NSRG4	Active	Production	SOP (NS)   16	2000   LARGE T&R	Yes	NIPDAU	Level-1-260C-UNLIM	-55 to 125	HC192M
<a href="#">CD74HC192PWR</a>	Active	Production	TSSOP (PW)   16	2000   LARGE T&R	Yes	NIPDAU	Level-1-260C-UNLIM	-55 to 125	HJ192
CD74HC192PWR.A	Active	Production	TSSOP (PW)   16	2000   LARGE T&R	Yes	NIPDAU	Level-1-260C-UNLIM	-55 to 125	HJ192
<a href="#">CD74HC192PWT</a>	Obsolete	Production	TSSOP (PW)   16	-	-	Call TI	Call TI	-55 to 125	HJ192
<a href="#">CD74HC193E</a>	Active	Production	PDIP (N)   16	25   TUBE	Yes	NIPDAU	N/A for Pkg Type	-55 to 125	CD74HC193E
CD74HC193E.A	Active	Production	PDIP (N)   16	25   TUBE	Yes	NIPDAU	N/A for Pkg Type	-55 to 125	CD74HC193E
<a href="#">CD74HC193M</a>	Obsolete	Production	SOIC (D)   16	-	-	Call TI	Call TI	-55 to 125	HC193M
<a href="#">CD74HC193M96</a>	Active	Production	SOIC (D)   16	2500   LARGE T&R	Yes	NIPDAU	Level-1-260C-UNLIM	-55 to 125	HC193M
CD74HC193M96.A	Active	Production	SOIC (D)   16	2500   LARGE T&R	Yes	NIPDAU	Level-1-260C-UNLIM	-55 to 125	HC193M

Orderable part number	Status (1)	Material type (2)	Package   Pins	Package qty   Carrier	RoHS (3)	Lead finish/ Ball material (4)	MSL rating/ Peak reflow (5)	Op temp (°C)	Part marking (6)
<a href="#">CD74HC193MT</a>	Obsolete	Production	SOIC (D)   16	-	-	Call TI	Call TI	-55 to 125	HC193M
<a href="#">CD74HCT193E</a>	Active	Production	PDIP (N)   16	25   TUBE	Yes	NIPDAU	N/A for Pkg Type	-55 to 125	CD74HCT193E
CD74HCT193E.A	Active	Production	PDIP (N)   16	25   TUBE	Yes	NIPDAU	N/A for Pkg Type	-55 to 125	CD74HCT193E

<sup>(1)</sup> **Status:** For more details on status, see our [product life cycle](#).

<sup>(2)</sup> **Material type:** When designated, preproduction parts are prototypes/experimental devices, and are not yet approved or released for full production. Testing and final process, including without limitation quality assurance, reliability performance testing, and/or process qualification, may not yet be complete, and this item is subject to further changes or possible discontinuation. If available for ordering, purchases will be subject to an additional waiver at checkout, and are intended for early internal evaluation purposes only. These items are sold without warranties of any kind.

<sup>(3)</sup> **RoHS values:** Yes, No, RoHS Exempt. See the [TI RoHS Statement](#) for additional information and value definition.

<sup>(4)</sup> **Lead finish/Ball material:** Parts may have multiple material finish options. Finish options are separated by a vertical ruled line. Lead finish/Ball material values may wrap to two lines if the finish value exceeds the maximum column width.

<sup>(5)</sup> **MSL rating/Peak reflow:** The moisture sensitivity level ratings and peak solder (reflow) temperatures. In the event that a part has multiple moisture sensitivity ratings, only the lowest level per JEDEC standards is shown. Refer to the shipping label for the actual reflow temperature that will be used to mount the part to the printed circuit board.

<sup>(6)</sup> **Part marking:** There may be an additional marking, which relates to the logo, the lot trace code information, or the environmental category of the part.

Multiple part markings will be inside parentheses. Only one part marking contained in parentheses and separated by a "-" will appear on a part. If a line is indented then it is a continuation of the previous line and the two combined represent the entire part marking for that device.

**Important Information and Disclaimer:** The information provided on this page represents TI's knowledge and belief as of the date that it is provided. TI bases its knowledge and belief on information provided by third parties, and makes no representation or warranty as to the accuracy of such information. Efforts are underway to better integrate information from third parties. TI has taken and continues to take reasonable steps to provide representative and accurate information but may not have conducted destructive testing or chemical analysis on incoming materials and chemicals. TI and TI suppliers consider certain information to be proprietary, and thus CAS numbers and other limited information may not be available for release.

In no event shall TI's liability arising out of such information exceed the total purchase price of the TI part(s) at issue in this document sold by TI to Customer on an annual basis.

**OTHER QUALIFIED VERSIONS OF CD54HC192, CD54HC193, CD54HCT193, CD74HC192, CD74HC193, CD74HCT193 :**

● Catalog : [CD74HC192](#), [CD74HC193](#), [CD74HCT193](#)

● Military : [CD54HC192](#), [CD54HC193](#), [CD54HCT193](#)

**NOTE: Qualified Version Definitions:**

- Catalog - TI's standard catalog product
- Military - QML certified for Military and Defense Applications

**TAPE AND REEL INFORMATION**

**QUADRANT ASSIGNMENTS FOR PIN 1 ORIENTATION IN TAPE**

\*All dimensions are nominal

Device	Package Type	Package Drawing	Pins	SPQ	Reel Diameter (mm)	Reel Width W1 (mm)	A0 (mm)	B0 (mm)	K0 (mm)	P1 (mm)	W (mm)	Pin1 Quadrant
CD74HC192NSR	SOP	NS	16	2000	330.0	16.4	8.1	10.4	2.5	12.0	16.0	Q1
CD74HC192PWR	TSSOP	PW	16	2000	330.0	12.4	6.9	5.6	1.6	8.0	12.0	Q1
CD74HC193M96	SOIC	D	16	2500	330.0	16.4	6.5	10.3	2.1	8.0	16.0	Q1

**TAPE AND REEL BOX DIMENSIONS**

\*All dimensions are nominal

Device	Package Type	Package Drawing	Pins	SPQ	Length (mm)	Width (mm)	Height (mm)
CD74HC192NSR	SOP	NS	16	2000	353.0	353.0	32.0
CD74HC192PWR	TSSOP	PW	16	2000	353.0	353.0	32.0
CD74HC193M96	SOIC	D	16	2500	353.0	353.0	32.0

**TUBE**

\*All dimensions are nominal

Device	Package Name	Package Type	Pins	SPQ	L (mm)	W (mm)	T (μm)	B (mm)
CD74HC192E	N	PDIP	16	25	506	13.97	11230	4.32
CD74HC192E	N	PDIP	16	25	506	13.97	11230	4.32
CD74HC192E.A	N	PDIP	16	25	506	13.97	11230	4.32
CD74HC192E.A	N	PDIP	16	25	506	13.97	11230	4.32
CD74HC193E	N	PDIP	16	25	506	13.97	11230	4.32
CD74HC193E	N	PDIP	16	25	506	13.97	11230	4.32
CD74HC193E.A	N	PDIP	16	25	506	13.97	11230	4.32
CD74HC193E.A	N	PDIP	16	25	506	13.97	11230	4.32
CD74HCT193E	N	PDIP	16	25	506	13.97	11230	4.32
CD74HCT193E	N	PDIP	16	25	506	13.97	11230	4.32
CD74HCT193E.A	N	PDIP	16	25	506	13.97	11230	4.32
CD74HCT193E.A	N	PDIP	16	25	506	13.97	11230	4.32



# PACKAGE OUTLINE

## NS0016A

### SOP - 2.00 mm max height

SOP



4220735/A 12/2021

#### NOTES:

1. All linear dimensions are in millimeters. Dimensions in parenthesis are for reference only. Dimensioning and tolerancing per ASME Y14.5M.
2. This drawing is subject to change without notice.
3. This dimension does not include mold flash, protrusions, or gate burrs. Mold flash, protrusions, or gate burrs shall not exceed 0.15 mm, per side.
4. This dimension does not include interlead flash. Interlead flash shall not exceed 0.25 mm, per side.

# EXAMPLE BOARD LAYOUT

NS0016A

SOP - 2.00 mm max height

SOP



4220735/A 12/2021

NOTES: (continued)

5. Publication IPC-7351 may have alternate designs.

6. Solder mask tolerances between and around signal pads can vary based on board fabrication site.

# EXAMPLE STENCIL DESIGN

NS0016A

SOP - 2.00 mm max height

SOP



SOLDER PASTE EXAMPLE  
BASED ON 0.125 mm THICK STENCIL  
SCALE:7X

4220735/A 12/2021

NOTES: (continued)

7. Laser cutting apertures with trapezoidal walls and rounded corners may offer better paste release. IPC-7525 may have alternate design recommendations.
8. Board assembly site may have different recommendations for stencil design.

D (R-PDSO-G16)

PLASTIC SMALL OUTLINE



- NOTES:
- A. All linear dimensions are in inches (millimeters).
  - B. This drawing is subject to change without notice.
  - C. Body length does not include mold flash, protrusions, or gate burrs. Mold flash, protrusions, or gate burrs shall not exceed 0.006 (0,15) each side.
  - D. Body width does not include interlead flash. Interlead flash shall not exceed 0.017 (0,43) each side.
  - E. Reference JEDEC MS-012 variation AC.

J (R-GDIP-T\*\*)

14 LEADS SHOWN

CERAMIC DUAL IN-LINE PACKAGE



DIM \ PINS **	14	16	18	20
A	0.300 (7,62) BSC	0.300 (7,62) BSC	0.300 (7,62) BSC	0.300 (7,62) BSC
B MAX	0.785 (19,94)	.840 (21,34)	0.960 (24,38)	1.060 (26,92)
B MIN	—	—	—	—
C MAX	0.300 (7,62)	0.300 (7,62)	0.310 (7,87)	0.300 (7,62)
C MIN	0.245 (6,22)	0.245 (6,22)	0.220 (5,59)	0.245 (6,22)



4040083/F 03/03

- NOTES:
- All linear dimensions are in inches (millimeters).
  - This drawing is subject to change without notice.
  - This package is hermetically sealed with a ceramic lid using glass frit.
  - Index point is provided on cap for terminal identification only on press ceramic glass frit seal only.
  - Falls within MIL STD 1835 GDIP1-T14, GDIP1-T16, GDIP1-T18 and GDIP1-T20.

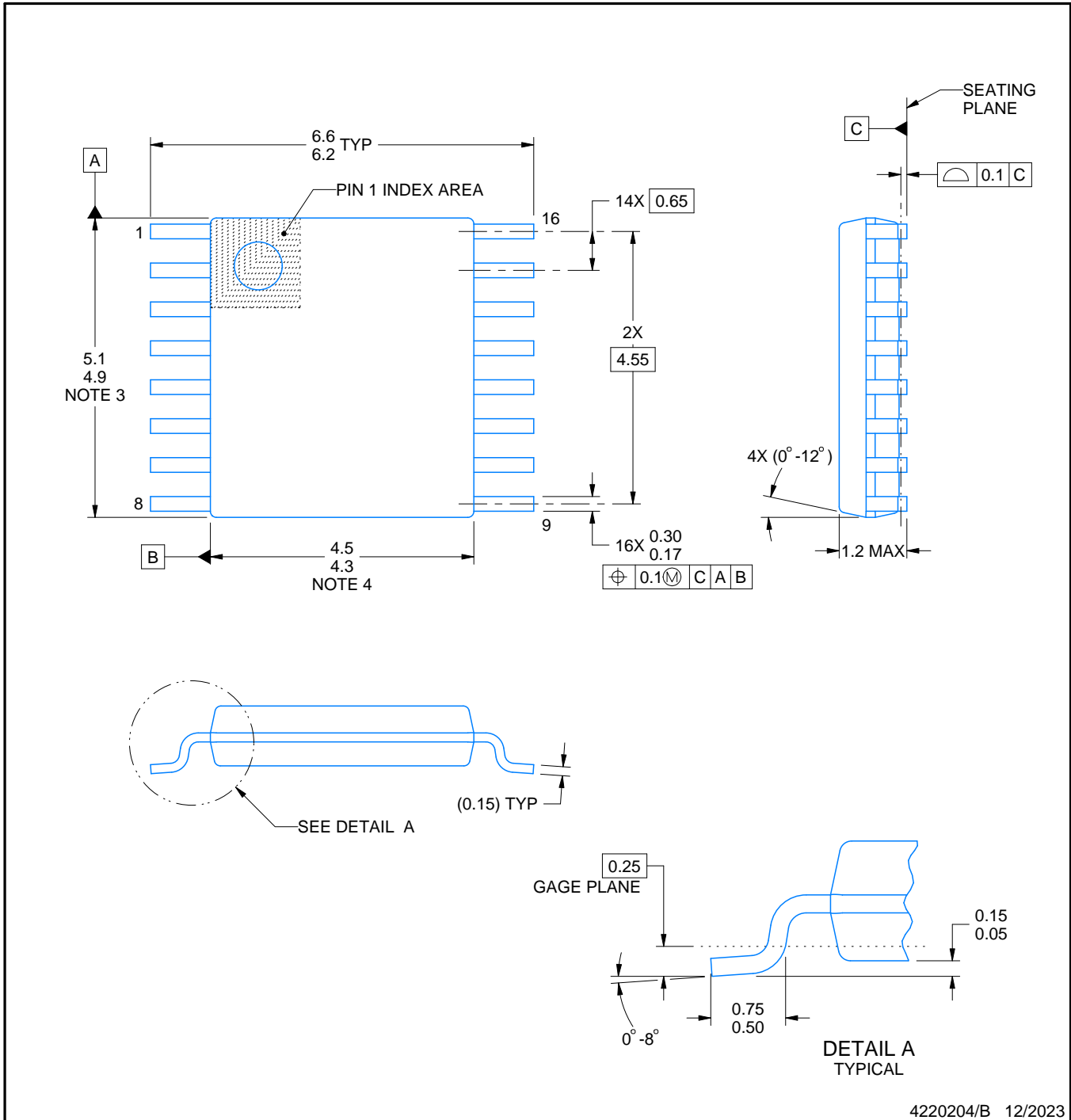

4220204/B 12/2023

NOTES:

1. All linear dimensions are in millimeters. Any dimensions in parenthesis are for reference only. Dimensioning and tolerancing per ASME Y14.5M.
2. This drawing is subject to change without notice.
3. This dimension does not include mold flash, protrusions, or gate burrs. Mold flash, protrusions, or gate burrs shall not exceed 0.15 mm per side.
4. This dimension does not include interlead flash. Interlead flash shall not exceed 0.25 mm per side.
5. Reference JEDEC registration MO-153.

# EXAMPLE BOARD LAYOUT

PW0016A

TSSOP - 1.2 mm max height

SMALL OUTLINE PACKAGE

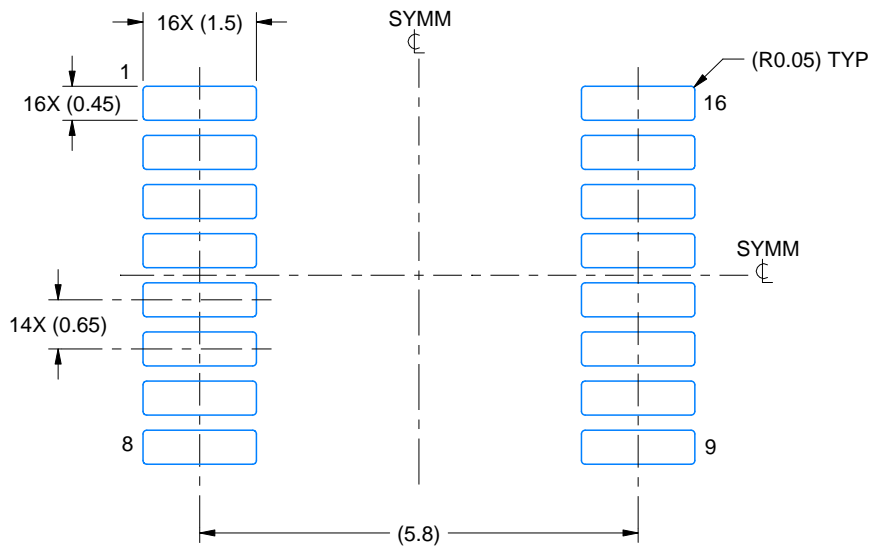

LAND PATTERN EXAMPLE  
EXPOSED METAL SHOWN  
SCALE: 10X

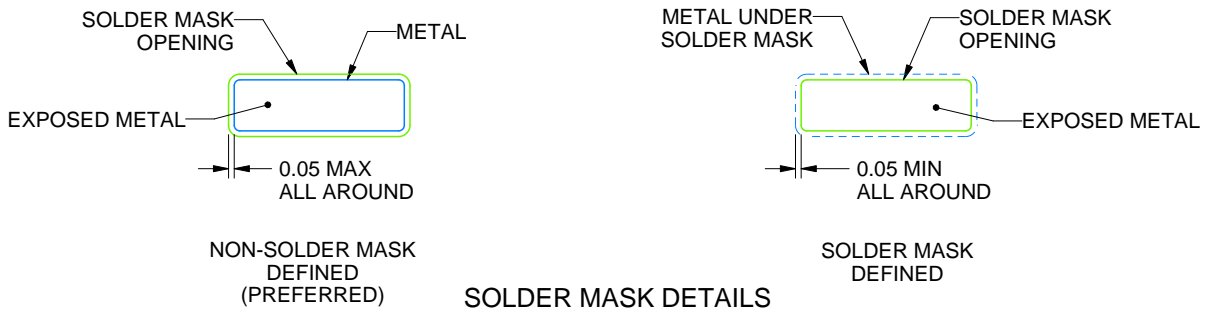

4220204/B 12/2023

NOTES: (continued)

- 6. Publication IPC-7351 may have alternate designs.
- 7. Solder mask tolerances between and around signal pads can vary based on board fabrication site.

# EXAMPLE STENCIL DESIGN

PW0016A

TSSOP - 1.2 mm max height

SMALL OUTLINE PACKAGE

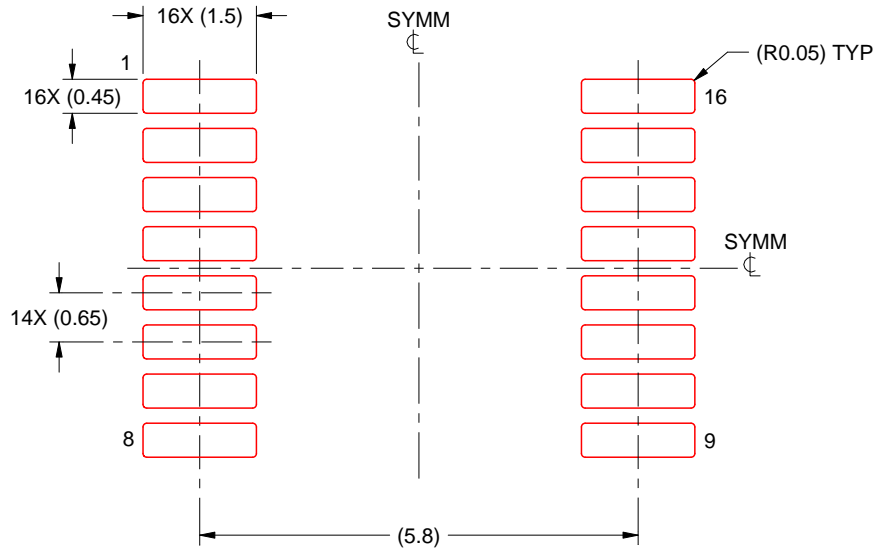

SOLDER PASTE EXAMPLE  
BASED ON 0.125 mm THICK STENCIL  
SCALE: 10X

4220204/B 12/2023

NOTES: (continued)

8. Laser cutting apertures with trapezoidal walls and rounded corners may offer better paste release. IPC-7525 may have alternate design recommendations.
9. Board assembly site may have different recommendations for stencil design.

N (R-PDIP-T\*\*)

PLASTIC DUAL-IN-LINE PACKAGE

16 PINS SHOWN

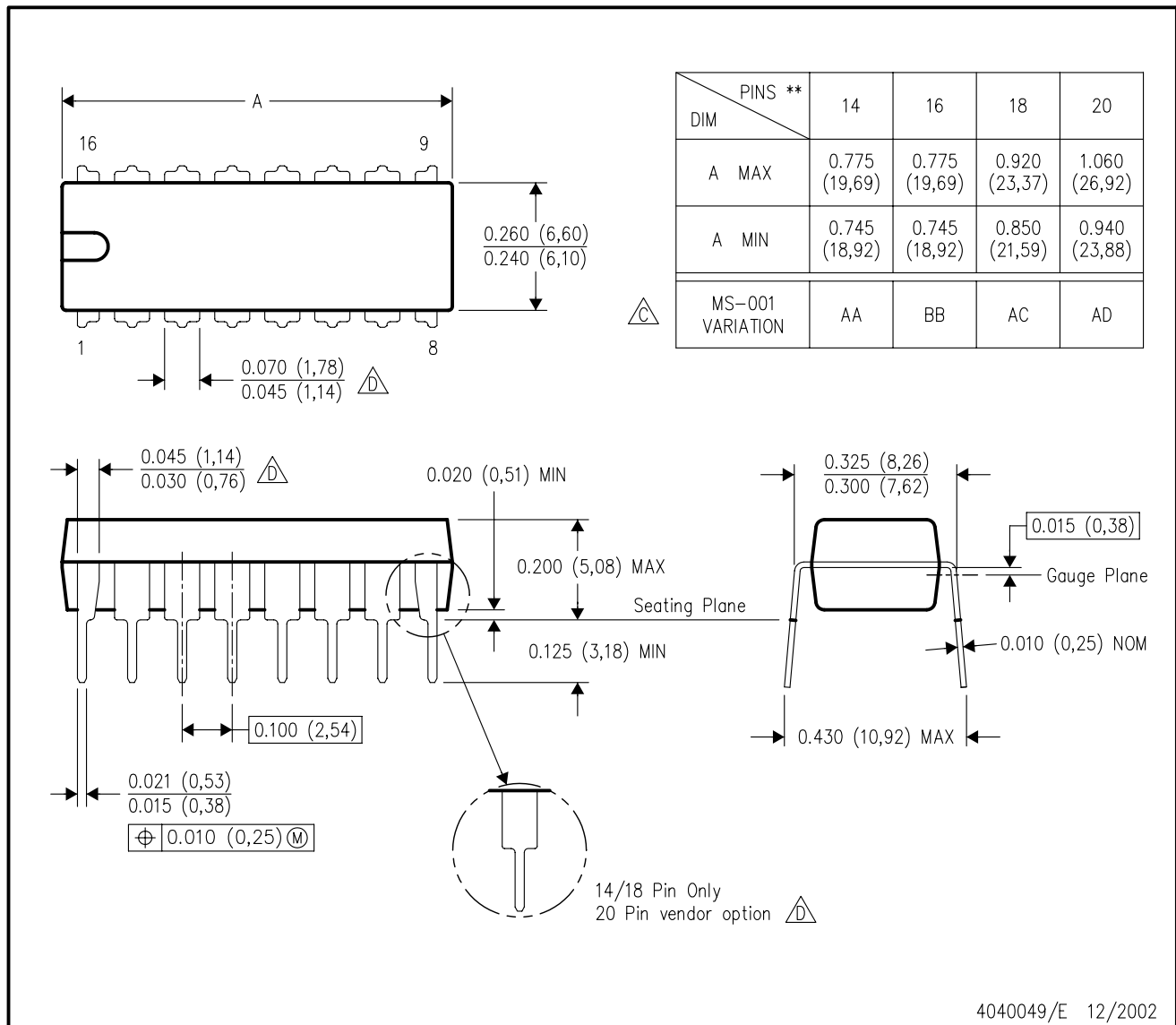

- NOTES:
- A. All linear dimensions are in inches (millimeters).
  - B. This drawing is subject to change without notice.
  - Falls within JEDEC MS-001, except 18 and 20 pin minimum body length (Dim A).
  - The 20 pin end lead shoulder width is a vendor option, either half or full width.

## IMPORTANT NOTICE AND DISCLAIMER

TI PROVIDES TECHNICAL AND RELIABILITY DATA (INCLUDING DATASHEETS), DESIGN RESOURCES (INCLUDING REFERENCE DESIGNS), APPLICATION OR OTHER DESIGN ADVICE, WEB TOOLS, SAFETY INFORMATION, AND OTHER RESOURCES "AS IS" AND WITH ALL FAULTS, AND DISCLAIMS ALL WARRANTIES, EXPRESS AND IMPLIED, INCLUDING WITHOUT LIMITATION ANY IMPLIED WARRANTIES OF MERCHANTABILITY, FITNESS FOR A PARTICULAR PURPOSE OR NON-INFRINGEMENT OF THIRD PARTY INTELLECTUAL PROPERTY RIGHTS.

These resources are intended for skilled developers designing with TI products. You are solely responsible for (1) selecting the appropriate TI products for your application, (2) designing, validating and testing your application, and (3) ensuring your application meets applicable standards, and any other safety, security, regulatory or other requirements.

These resources are subject to change without notice. TI grants you permission to use these resources only for development of an application that uses the TI products described in the resource. Other reproduction and display of these resources is prohibited. No license is granted to any other TI intellectual property right or to any third party intellectual property right. TI disclaims responsibility for, and you fully indemnify TI and its representatives against any claims, damages, costs, losses, and liabilities arising out of your use of these resources.

TI's products are provided subject to [TI's Terms of Sale](#), [TI's General Quality Guidelines](#), or other applicable terms available either on [ti.com](http://ti.com) or provided in conjunction with such TI products. TI's provision of these resources does not expand or otherwise alter TI's applicable warranties or warranty disclaimers for TI products. Unless TI explicitly designates a product as custom or customer-specified, TI products are standard, catalog, general purpose devices.

TI objects to and rejects any additional or different terms you may propose.

Copyright © 2026, Texas Instruments Incorporated

Last updated 10/2025