

CD4066B CMOS 四路双向开关

1 特性

- 15V 数字或 $\pm 7.5V$ 峰峰值开关
- 工作电压为 15V 时
典型导通电阻为 $125\ \Omega$
- 在 15V 信号输入范围内匹配的
开关导通电阻不超过 $5\ \Omega$
- 在整个峰峰值信号范围内具有
平坦的导通电阻
- 高开关输出电压比：
 $f_{is} = 10\text{kHz}$ 、 $R_L = 1\text{k}\ \Omega$ 时典型值为 80dB
- 高度线性： $f_{is} = 1\text{kHz}$ 、 $V_{is} = 5V_{p-p}$ 、
 $V_{DD} - V_{SS} \geq 10V$ 、 $R_L = 10\text{k}\ \Omega$ 时失真典型值小于 0.5%
- 超低关断状态开关泄漏，从而产生较低的失调电流
和高有效关断状态电阻： $V_{DD} - V_{SS} = 10V$ 、 $T_A = 25^\circ\text{C}$ 时的典型值为 10pA
- 较高控制输入阻抗
(控制电路与信号电路相隔离)：
典型值为 $10^{12}\ \Omega$
- 低开关间串扰： $f_{is} = 8\text{MHz}$ 、 $R_L = 1\text{k}\ \Omega$ 时典型值为
- 50dB
- 匹配的控制输入到信号输出电容：可减少输出信号
瞬态
- 频率响应，
开启 = 40MHz (典型值)
- 针对 20V 下的静态电流进行了 100% 测试
- 5V、10V 和 15V 参数额定值

2 应用

- 模拟信号开关和多路复用：信号门控、调制器、静
噪控制、解调器、斩波器、换向开关
- 数字信号开关和多路复用
- 模数和数模转换
- 频率、阻抗、相位和模拟信号增益的数字控制
- [楼宇自动化](#)

3 说明

CD4066B 器件是一款用于模拟或数字信号传输或多路复用的四路双向开关。该器件与 CD4016B 器件引脚对引脚兼容，但导通状态电阻低得多。此外，导通状态电阻在整个信号输入范围内相对恒定。

CD4066B 器件包含四个双向开关，每个开关都具有独立的控件。3V 至 18V 的宽工作电源电压范围支持用于广泛的应用。与单通道开关相比，优点包括峰值输入信号电压摆幅等于最大电源电压以及在输入信号范围内具有更恒定的导通状态阻抗。而对于采样保持应用，建议使用 CD4016B 器件。

封装信息

器件型号	封装 ⁽¹⁾	封装尺寸 ⁽²⁾
CD4066B	N (PDIP , 14)	19.3mm × 9.4mm
	D (SOIC , 14)	8.65mm × 6mm
	NS (SOP , 14)	10.2mm × 7.8mm
	PW (TSSOP , 14)	5mm × 6.4mm

(1) 有关更多信息，请参阅节 11

(2) 封装尺寸 (长 × 宽) 为标称值，并包括引脚 (如适用)。

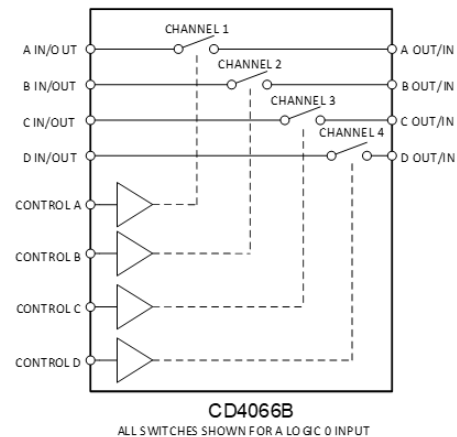

通过数字控制逻辑进行双向信号传输



Table of Contents

1 特性	1	7.3 Feature Description.....	14
2 应用	1	7.4 Device Functional Modes.....	15
3 说明	1	8 Application and Implementation	16
4 Pin Configuration and Functions	3	8.1 Application Information.....	16
5 Specifications	4	8.2 Typical Application.....	16
5.1 Absolute Maximum Ratings.....	4	8.3 Power Supply Recommendations.....	17
5.2 ESD Ratings.....	4	8.4 Layout.....	17
5.3 Recommended Operating Conditions.....	4	9 Device and Documentation Support	19
5.4 Thermal Information.....	5	9.1 接收文档更新通知.....	19
5.5 Electrical Characteristics.....	5	9.2 支持资源.....	19
5.6 Switching Characteristics.....	8	9.3 Trademarks.....	19
5.7 Typical Characteristics.....	9	9.4 静电放电警告.....	19
6 Parameter Measurement Information	10	9.5 术语表.....	19
7 Detailed Description	14	10 Revision History	19
7.1 Overview.....	14	11 Mechanical, Packaging, and Orderable Information	19
7.2 Functional Block Diagram.....	14		

4 Pin Configuration and Functions



图 4-1. N, J, D, NS, or PW Packages 14-Pin PDIP, CDIP, SOIC, SOP, or TSSOP (Top View)

表 4-1. Pin Functions

PIN		TYPE ⁽¹⁾	DESCRIPTION
NAME	NO.		
SIG A IN/OUT	1	I/O	Input/Output for Switch A
SIG A OUT/IN	2	I/O	Output/Input for Switch A
SIG B OUT/IN	3	I/O	Output/Input for Switch B
SIG B IN/OUT	4	I/O	Input/Output for Switch B
CONTROL B	5	I	Control pin for Switch B
CONTROL C	6	I	Control pin for Switch C
V _{SS}	7	—	Low Voltage Power Pin
SIG C IN/OUT	8	I/O	Input/Output for Switch C
SIG C OUT/IN	9	I/O	Output/Input for Switch C
SIG D OUT/IN	10	I/O	Output/Input for Switch D
SIG D IN/OUT	11	I/O	Input/Output for Switch D
CONTROL D	12	I	Control Pin for D
CONTROL A	13	I	Control Pin for A
V _{DD}	14	—	Power Pin

(1) I = input, O = output

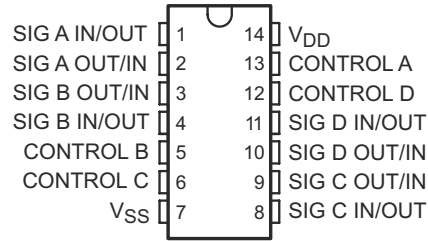
5 Specifications

5.1 Absolute Maximum Ratings

over operating free-air temperature range (unless otherwise noted)^{(1) (2)}

		MIN	MAX	UNIT
$V_{DD} - V_{SS}$	Supply voltage		20	V
V_{DD}		- 0.5	20	V
V_{SS}		- 20	0.5	V
I_{SEL} or I_{EN}	Logic control input pin current (\overline{EN} , Ax, SELx)	- 30	30	mA
V_S or V_D	Source or drain voltage (Sx, D)	$V_{SS} - 0.5$	$V_{DD} + 0.5$	V
I_S or I_D (CONT)	Source or drain continuous current (Sx, D)	- 20	20	mA
T_J	Junction temperature		150	°C
T_{stg}	Storage temperature	- 65	150	°C

- (1) Stresses beyond those listed under *Absolute Maximum Rating* may cause permanent damage to the device. These are stress ratings only, which do not imply functional operation of the device at these or any other conditions beyond those indicated under *Recommended Operating Condition*. Exposure to absolute-maximum-rated conditions for extended periods may affect device reliability.
- (2) All voltages are with respect to ground, unless otherwise specified.

5.2 ESD Ratings

		VALUE	UNIT
$V_{(ESD)}$	Electrostatic discharge	Human body model (HBM), per ANSI/ESDA/JEDEC JS-001, all pins ⁽¹⁾	±500
		Charged device model (CDM), per JEDEC specification JESD22-C101, all pins ⁽²⁾	±1500

- (1) JEDEC document JEP155 states that 500V HBM allows safe manufacturing with a standard ESD control process.
- (2) JEDEC document JEP157 states that 250V CDM allows safe manufacturing with a standard ESD control process.

5.3 Recommended Operating Conditions

over operating free-air temperature range (unless otherwise noted)

		MIN	NOM	MAX	UNIT
$V_{DD} - V_{SS}$ ⁽¹⁾	Power supply voltage differential	3		18	V
V_{DD}	Positive power supply voltage	3		18	V
V_S or V_D	Signal path input/output voltage (source or drain pin) (Sx, D)	V_{SS}		V_{DD}	V
V_{SEL} or V_{EN}	Address or enable pin voltage	0		V_{DD}	V
I_S or I_D (CONT)	Source or drain continuous current (Sx, D)	- 10		10	mA
T_A	Ambient temperature	- 55		125	°C

- (1) V_{DD} and V_{SS} can be any value as long as $3V \leq (V_{DD} - V_{SS}) \leq 24V$, and the minimum V_{DD} is met.

5.4 Thermal Information

THERMAL METRIC ⁽¹⁾		CD406x				UNIT
		N (PDIP)	D (SOIC)	NS (SO)	PW (TSSOP)	
		14 PINS	14 PINS	14 PINS	14 PINS	
$R_{\theta JA}$	Junction-to-ambient thermal resistance	93.7	109.7	112.4	101.8	°C/W
$R_{\theta JC(top)}$	Junction-to-case (top) thermal resistance	72.5	69.4	70.4	44.3	°C/W
$R_{\theta JB}$	Junction-to-board thermal resistance	68.0	67.9	76.4	68.2	°C/W
Ψ_{JT}	Junction-to-top characterization parameter	50.3	25.8	28.9	3.2	°C/W
Ψ_{JB}	Junction-to-board characterization parameter	67.3	67.1	75.4	67.6	°C/W

(1) For more information about traditional and new thermal metrics, see the [Semiconductor and IC Package Thermal Metrics](#) application report.

5.5 Electrical Characteristics

Over operating free-air temperature range, $V_{SUPPLY} = \pm 5V$, and $R_L = 100 \Omega$, (unless otherwise noted)⁽¹⁾

PARAMETER		TEST CONDITIONS		MIN	TYP	MAX	UNIT
SIGNAL INPUTS (V_{IS}) AND OUTPUTS (V_{OS})							
V_{OS}	Switch output voltage	$V_{DD} = 5V$ $V_{IS} = 0V$				0.4	V
		$V_{DD} = 5V$ $V_{IS} = 5V$			4.6		V
		$V_{DD} = 10V$ $V_{IS} = 0V$				0.5	V
		$V_{DD} = 10V$ $V_{IS} = 10V$			9.5		V
		$V_{DD} = 15V$ $V_{IS} = 0V$				1.5	V
		$V_{DD} = 15V$ $V_{IS} = 15V$			13.5		V
ΔR_{ON}	On-state resistance difference between any two switches		$R_L = 10k\Omega$, $V_C = V_{DD}$	$V_{DD} = 5V$		15	Ω
	On-state resistance difference between any two switches	On-state resistance difference between any two switches		$V_{DD} = 10V$		10	
	On-state resistance difference between any two switches	On-state resistance difference between any two switches		$V_{DD} = 15V$		5	
V_{IHC}	Control input, high voltage		See Figure 7	$V_{DD} = 5V$		3.5	V
				$V_{DD} = 10V$		7	V
				$V_{DD} = 15V$		11	V

5.5 Electrical Characteristics (续)

Over operating free-air temperature range, $V_{SUPPLY} = \pm 5V$, and $R_L = 100 \Omega$, (unless otherwise noted)⁽¹⁾

PARAMETER		TEST CONDITIONS			MIN	TYP	MAX	UNI T
	Maximum control input repetition rate	$V_{IN} = V_{DD}$, $C_L = 50pF$, $R_L = 1k\Omega$ $V_C = 10V$ (square wave centered on 5V), $t_r, t_f = 20ns$, $V_{os} = 1/2V_{os}$ at 1kHz	$V_{DD} = 5V$			6	MHz	
			$V_{DD} = 10V$			9		
			$V_{DD} = 15V$			9.5		
C_{IN}	Input Capacitance				5	7.5	pF	
I_{IS}	Switch input current	$V_{DD} = 5V$ $V_{is} = 0V$	$T_A = -55^\circ C$				0.64	mA
			$T_A = -40^\circ C$				0.61	
			$T_A = 25^\circ C$			0.51		
			$T_A = 85^\circ C$			0.42		
			$T_A = 125^\circ C$			0.36		
		$V_{DD} = 5V$ $V_{is} = 5V$	$T_A = -55^\circ C$				-0.64	mA
			$T_A = -40^\circ C$				-0.61	
			$T_A = 25^\circ C$			-0.51		
			$T_A = 85^\circ C$			-0.42		
			$T_A = 125^\circ C$			-0.36		
		$V_{DD} = 10V$ $V_{is} = 0V$	$T_A = -55^\circ C$				1.6	mA
			$T_A = -40^\circ C$				1.5	
			$T_A = 25^\circ C$			1.3		
			$T_A = 85^\circ C$			1.1		
			$T_A = 125^\circ C$			0.9		
		$V_{DD} = 10V$ $V_{is} = 10V$	$T_A = -55^\circ C$				-1.6	mA
			$T_A = -40^\circ C$				-1.5	
			$T_A = 25^\circ C$			-1.3		
			$T_A = 85^\circ C$			-1.1		
			$T_A = 125^\circ C$			-0.9		
		$V_{DD} = 15V$ $V_{is} = 0V$	$T_A = -55^\circ C$				4.2	mA
			$T_A = -40^\circ C$				4	
			$T_A = 25^\circ C$			3.4		
			$T_A = 85^\circ C$			2.8		
$T_A = 125^\circ C$				2.4				
$V_{DD} = 15V$ $V_{is} = 15V$	$T_A = -55^\circ C$				-4.2	mA		
	$T_A = -40^\circ C$				-4			
	$T_A = 25^\circ C$			-3.4				
	$T_A = 85^\circ C$			-2.8				
	$T_A = 125^\circ C$			-2.4				

5.5 Electrical Characteristics (续)

Over operating free-air temperature range, $V_{SUPPLY} = \pm 5V$, and $R_L = 100 \Omega$, (unless otherwise noted)⁽¹⁾

PARAMETER		TEST CONDITIONS			MIN	TYP	MAX	UNI T
I_{DD}	Quiescent Device Current All switches OFF	$V_{is} = 0$ to 5V $V_{DD} = 5V$	$T_A = -55^\circ C$				5	μA
			$T_A = -40^\circ C$				5	
			$T_A = 25^\circ C$			4	6	
			$T_A = 85^\circ C$				7	
			$T_A = 125^\circ C$				7.5	
		$V_{is} = 0$ to 10V $V_{DD} = 10V$	$T_A = -55^\circ C$				6	
			$T_A = -40^\circ C$				6	
			$T_A = 25^\circ C$			5	7	
			$T_A = 85^\circ C$				8	
			$T_A = 125^\circ C$				9	
		$V_{is} = 0$ to 15V $V_{DD} = 15V$	$T_A = -55^\circ C$				7	
			$T_A = -40^\circ C$				7.5	
			$T_A = 25^\circ C$			5.5	8	
			$T_A = 85^\circ C$				9	
			$T_A = 125^\circ C$				10	
		$V_{is} = 0$ to 20V $V_{DD} = 20V$	$T_A = -55^\circ C$				8.5	
			$T_A = -40^\circ C$				8.5	
			$T_A = 25^\circ C$			6.5	9	
			$T_A = 85^\circ C$				10	
			$T_A = 125^\circ C$				11	
r_{ON}	ON Resistance r_{ON} Max	to $(V_{DD}+V_{SS})/2$, V_C $= V_{DD}$, $R_L = 10k \Omega$ returned $V_{is} = V_{SS}$ to V_{DD}	$V_{DD} = 5V$	$T_A = -55^\circ C$			800	Ω
				$T_A = -40^\circ C$			850	
				$T_A = 25^\circ C$		470	1050	
				$T_A = 85^\circ C$			1200	
				$T_A = 125^\circ C$			1300	
			$V_{DD} = 10V$	$T_A = -55^\circ C$			310	
				$T_A = -40^\circ C$			330	
				$T_A = 25^\circ C$		180	400	
				$T_A = 85^\circ C$			500	
				$T_A = 125^\circ C$			500	
			$V_{DD} = 15V$	$T_A = -55^\circ C$			200	
				$T_A = -40^\circ C$			210	
$T_A = 25^\circ C$		125		240				
$T_A = 85^\circ C$				300				
			$T_A = 125^\circ C$			320		

5.5 Electrical Characteristics (续)

Over operating free-air temperature range, $V_{SUPPLY} = \pm 5V$, and $R_L = 100 \Omega$, (unless otherwise noted)⁽¹⁾

PARAMETER		TEST CONDITIONS			MIN	TYP	MAX	UNIT
V_{ILC}	Control input, low voltage (max)	$ I_{is} < 10 \mu A$, $V_{is} = V_{SS}$, $V_{OS} = V_{DD}$, and $V_{is} = V_{DD}$, $V_{OS} = V_{SS}$	$V_{DD} = 5V$	$T_A = -55^\circ C$			1	V
				$T_A = -40^\circ C$			1	
				$T_A = 25^\circ C$			1	
				$T_A = 85^\circ C$			1	
				$T_A = 125^\circ C$			1	
			$V_{DD} = 10V$	$T_A = -55^\circ C$			1	
				$T_A = -40^\circ C$			1	
				$T_A = 25^\circ C$			1	
				$T_A = 85^\circ C$			1	
				$T_A = 125^\circ C$			1	
			$V_{DD} = 15V$	$T_A = -55^\circ C$			1	
				$T_A = -40^\circ C$			1	
				$T_A = 25^\circ C$			1	
				$T_A = 85^\circ C$			1	
				$T_A = 125^\circ C$			1	
I_{IN}	Input current (max)	$V_{is} \leq V_{DD}$, $V_{DD} - V_{SS} = 18V$, $V_{CC} \leq V_{DD} - V_{SS}$, $V_{DD} = 18V$	$T_A = -55^\circ C$		-0.8	0.8	μA	
			$T_A = -40^\circ C$		-0.8	0.8		
	$T_A = 25^\circ C$			-0.7	± 0.2	0.7		
	$T_A = 85^\circ C$			-0.6	0.6			
	$T_A = 125^\circ C$			-0.55	0.55			

(1) Peak-to-Peak voltage symmetrical about $(V_{DD} - V_{EE}) / 2$.

5.6 Switching Characteristics

$T_A = 25^\circ C$

PARAMETER	FROM	TO	TEST CONDITIONS	V_{CC}	MIN	TYP	MAX	UNIT
t_{pd}	Signal input	Signal output	$V_{IN} = V_{DD}$, $t_r, t_f = 20ns$, $C_L = 50pF$, $R_L = 1k \Omega$	5V		20	40	ns
				10V		10	20	
				15V		7	15	
t_{plh}	Signal input	Signal output	$V_{IN} = V_{DD}$, $t_r, t_f = 20ns$, $C_L = 50pF$, $R_L = 1k \Omega$	5V		35	70	ns
				10V		20	40	
				15V		15	30	
t_{phi}	Signal input	Signal output	$V_{IN} = V_{DD}$, $t_r, t_f = 20ns$, $C_L = 50pF$, $R_L = 1k \Omega$	5V		35	70	ns
				10V		20	40	
				15V		15	30	

5.7 Typical Characteristics

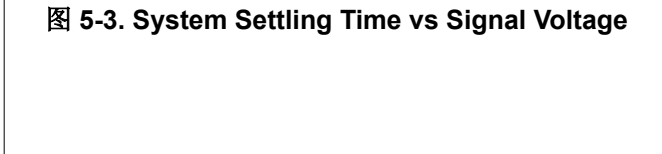
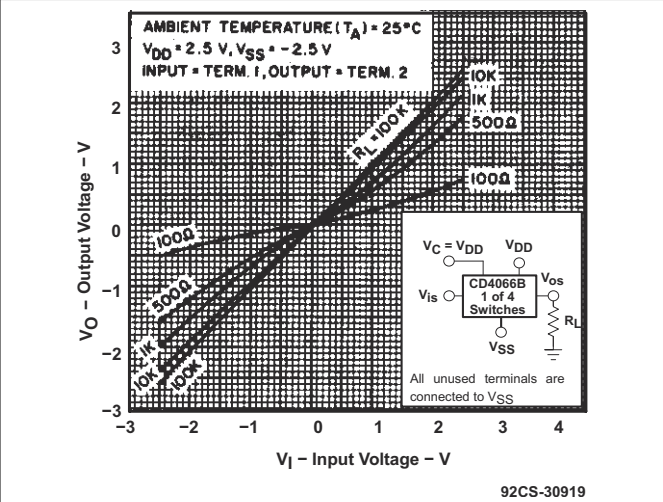
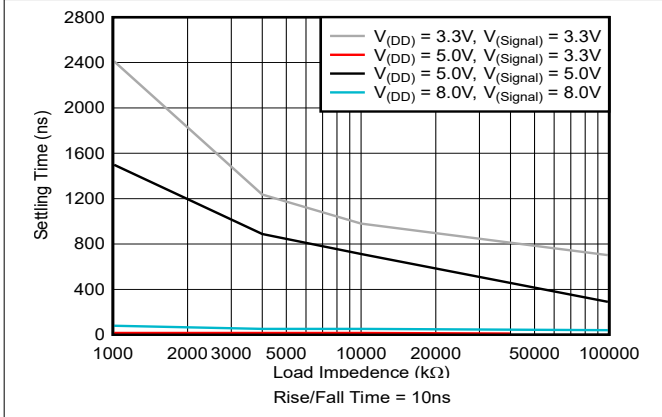
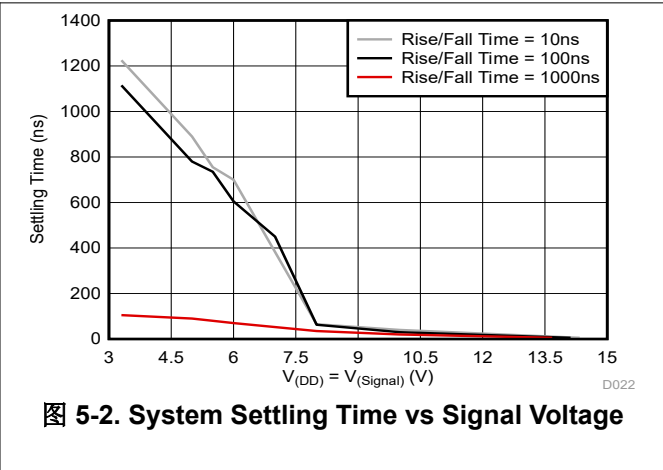
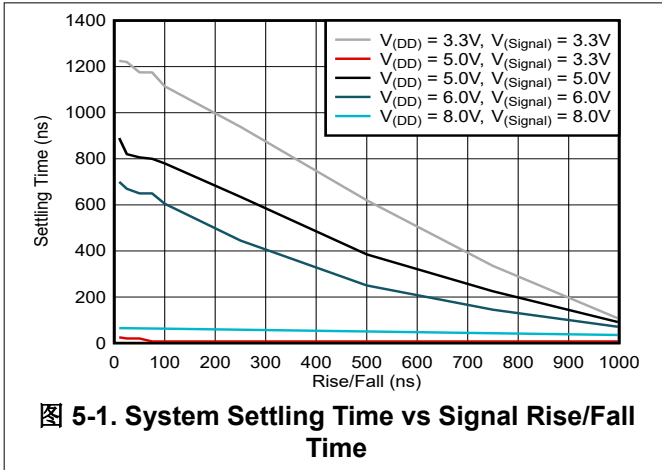

6 Parameter Measurement Information



图 6-1. Determination of r_{on} as a Test Condition for Control-Input High-Voltage (V_{IHC}) Specification



图 6-2. Channel On-State Resistance Measurement Circuit

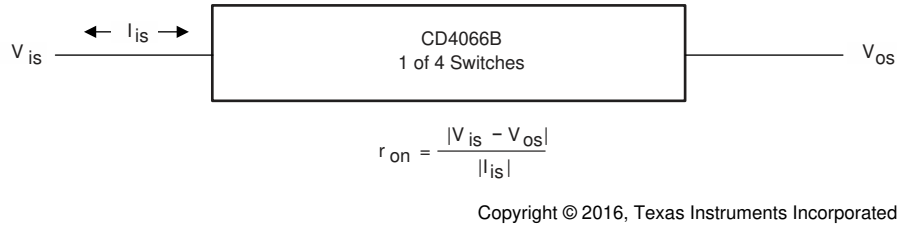

Measured on Boonton capacitance bridge, model 75a (1 MHz);
test-fixture capacitance nulled out.

图 6-3. Typical On Characteristics for One of Four Channels

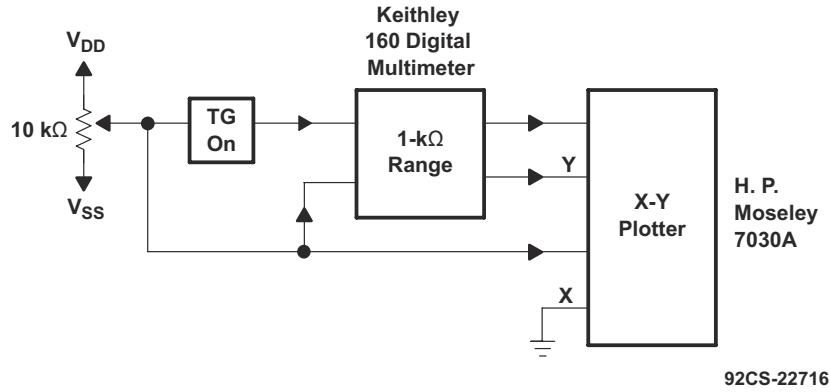
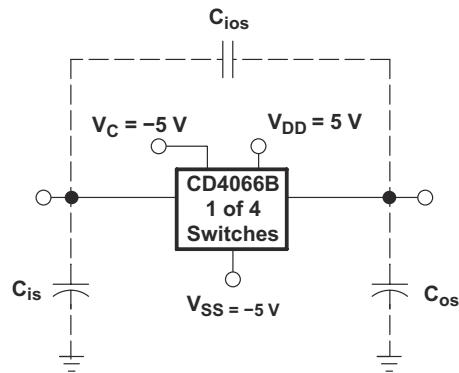
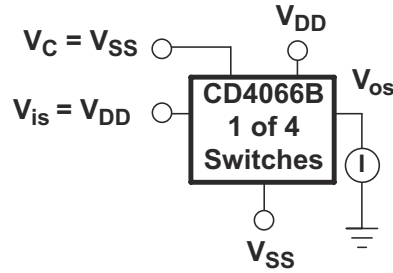

92CS-30922

All unused terminals are connected to V_{SS} .

图 6-4. Off-Switch Input or Output Leakage

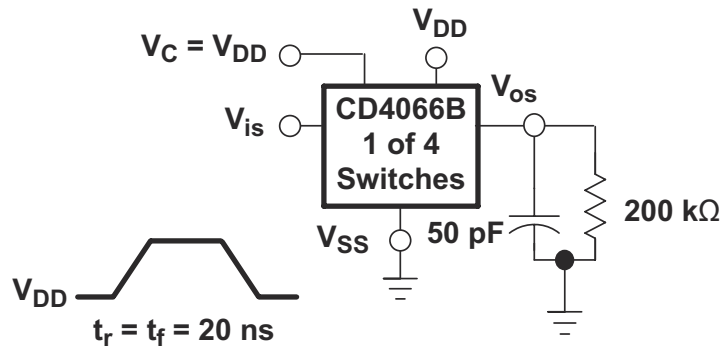

92CS-30923

All unused terminals are connected to V_{SS} .

图 6-5. Propagation Delay Time Signal Input (V_{is}) to Signal Output (V_{os})

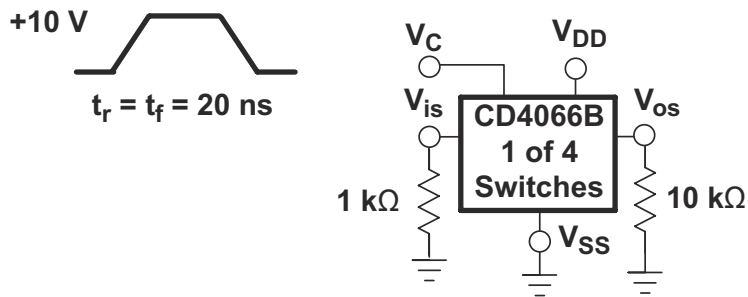

92CS-30924

All unused terminals are connected to V_{SS} .

图 6-6. Crosstalk-Control Input to Signal Output

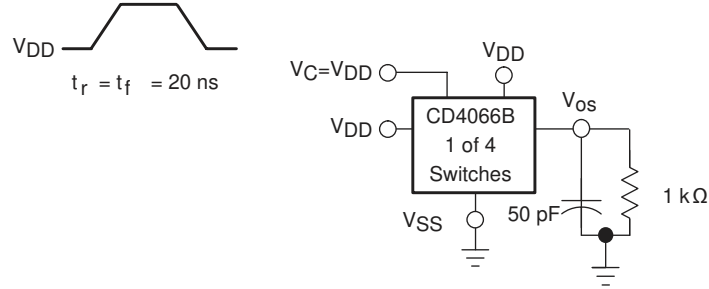

Copyright © 2016, Texas Instruments Incorporated

All unused pins are connected to VSS.

Delay is measured at Vos level of +10% from ground (turn-on) or on-state output level (turn-off).

图 6-7. Propagation Delay, t_{PLH}, t_{PHL} Control-Signal Output

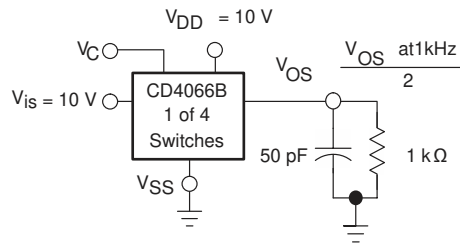
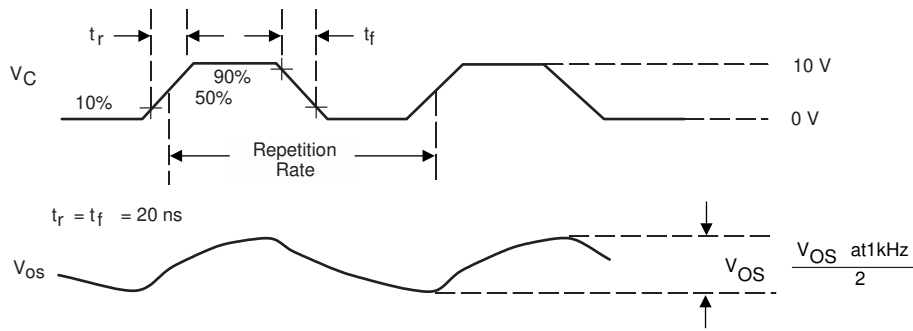

Copyright © 2016, Texas Instruments Incorporated

All unused pins are connected to VSS.

图 6-8. Maximum Allowable Control-Input Repetition Rate

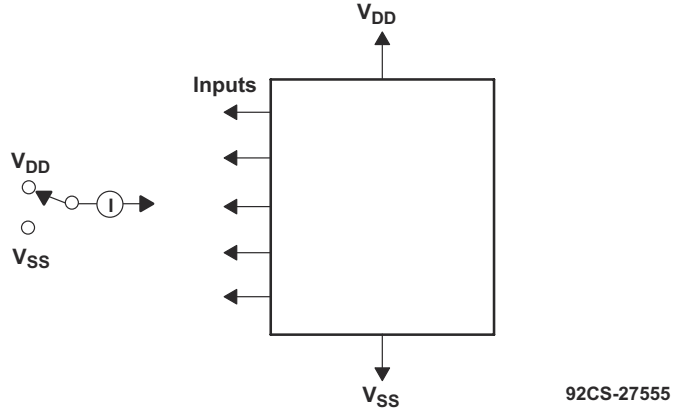

Measure inputs sequentially to both V_{DD} and V_{SS} . Connect all unused inputs to either V_{DD} or V_{SS} . Measure control inputs only.

图 6-9. Input Leakage-Current Test Circuit

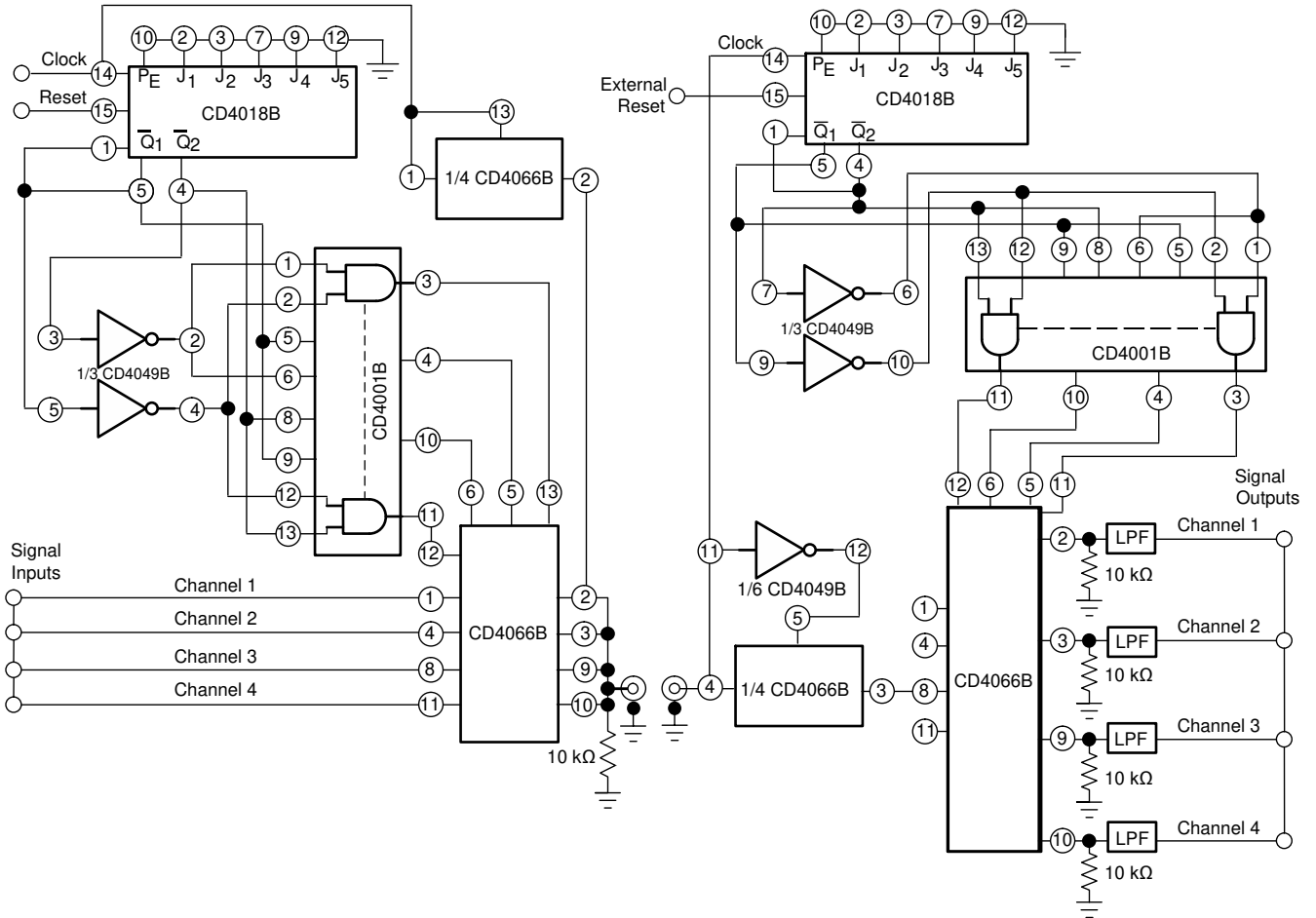

Copyright © 2016, Texas Instruments Incorporated

图 6-10. Four-Channel PAM Multiplex System Diagram

7 Detailed Description

7.1 Overview

CD4066B has four independent digitally controlled analog switches with a bias voltage of V_{SS} to allow for different voltage levels to be used for low output. Both the p and n devices in a given switch are biased on or off simultaneously by the control signal. As shown in 图 7-1, the well of the n-channel device on each switch is tied to either the input (when the switch is on) or to V_{SS} (when the switch is off). Thus, when the control of the device is low, the output of the switch goes to V_{SS} and when the control is high the output of the device goes to V_{DD} .

7.2 Functional Block Diagram

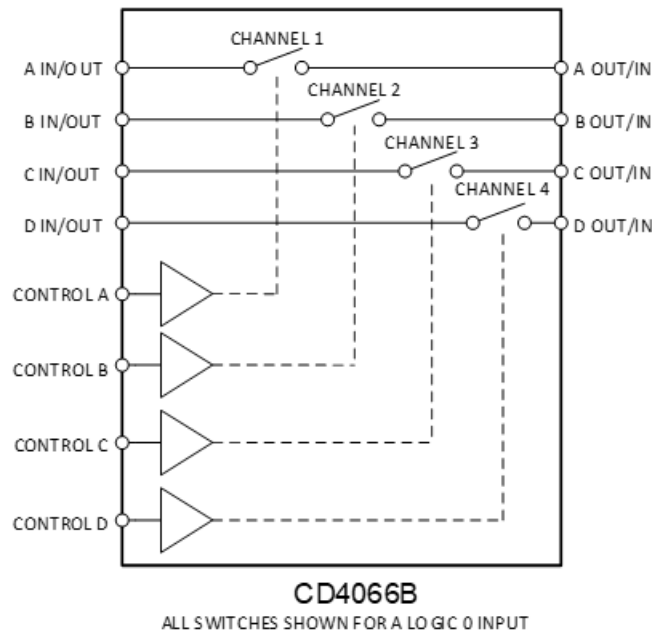

- All control inputs are protected by the CMOS protection network.
- All p substrates are connected to V_{DD} .
- Normal operation control-line biasing: switch on (logic 1), $V_C = V_{DD}$; switch off (logic 0), $V_C = V_{SS}$.
- Signal-level range: $V_{SS} \leq V_{is} \leq V_{DD}$.

图 7-1. Schematic Diagram of One-of-Four Identical Switches and Associated Control Circuitry

7.3 Feature Description

Each switch has different control pins, which allows for more options for the outputs. Bias Voltage allows the device to output a voltage other than 0V when the device control is low. The CD4066B has a large absolute maximum voltage for V_{DD} of 20V.

7.4 Device Functional Modes

表 7-1 lists the functions of this device.

表 7-1. Function Table

INPUTS		OUTPUT
SIG IN/OUT	CONTROL	SIG OUT/IN
H	H	H
L	H	L
X	L	Hi-Z

8 Application and Implementation

备注

以下应用部分中的信息不属于 TI 器件规格的范围，TI 不担保其准确性和完整性。TI 的客户应负责确定器件是否适用于其应用。客户应验证并测试其设计，以确保系统功能。

8.1 Application Information

In applications that employ separate power sources to drive V_{DD} and the signal inputs, the V_{DD} current capability should exceed V_{DD}/R_L (R_L = effective external load of the four CD4066B device bilateral switches). This provision avoids any permanent current flow or clamp action on the V_{DD} supply when power is applied or removed from the CD4066B device.

In certain applications, the external load-resistor current can include both V_{DD} and signal-line components. To avoid drawing V_{DD} current when switch current flows into pins 1, 4, 8, or 11, the voltage drop across the bidirectional switch must not exceed 0.8V (calculated from r_{on} values shown).

No V_{DD} current flows through R_L if the switch current flows into pins 2, 3, 9, or 10.

8.2 Typical Application

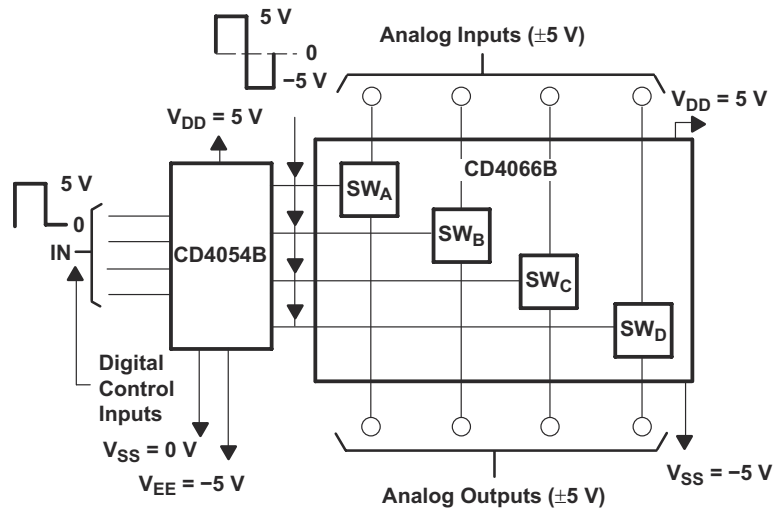

92CS-30927

图 8-1. Bidirectional Signal Transmission Through Digital Control Logic

8.2.1 Design Requirements

This device uses CMOS technology and has balanced output drive. Avoid bus contention because it can drive currents in excess of maximum limits. The high drive also creates fast edges into light loads, so consider routing and load conditions to prevent ringing.

8.2.2 Detailed Design Procedure

- Recommended input conditions:
 - For rise time and fall time specifications, see $\Delta t / \Delta v$ in [Recommended Operating Conditions](#).
 - For specified high and low levels, see V_{IH} and V_{IL} in [Recommended Operating Conditions](#).
- Recommended output conditions:
 - Load currents should not exceed $\pm 10\text{mA}$.

8.2.3 Application Curve



图 8-2. Power Dissipation vs. Switching Frequency

8.3 Power Supply Recommendations

The power supply can be any voltage between the MIN and MAX supply voltage rating located in [Recommended Operating Conditions](#).

Each VCC pin should have a good bypass capacitor to prevent power disturbance. For devices with a single supply, $0.1\mu\text{F}$ is recommended; if there are multiple VCC pins, then $0.01\mu\text{F}$ or $0.022\mu\text{F}$ is recommended for each power pin. It is acceptable to parallel multiple bypass capacitors to reject different frequencies of noise. A $0.1\mu\text{F}$ and a $1\mu\text{F}$ are commonly used in parallel. The bypass capacitor should be installed as close to the power pin as possible for best results.

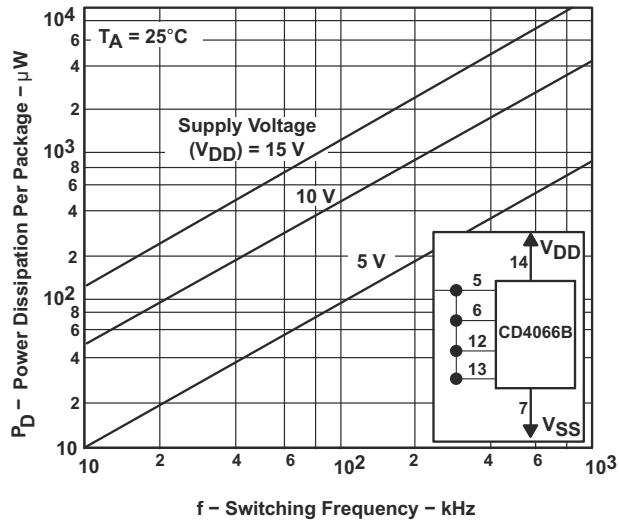
8.4 Layout

8.4.1 Layout Guidelines

When using multiple bit logic devices inputs must never float.

In many cases, functions or parts of functions of digital logic devices are unused, for example, when only two inputs of a triple-input *and* gate are used or only 3 of the 4 buffer gates are used. Such input pins must not be left unconnected because the undefined voltages at the outside connections result in undefined operational states. All unused inputs of digital logic devices must be connected to a high or low bias to prevent them from floating. The logic level that should be applied to any particular unused input depends on the function of the device. Generally they are tied to GND or VCC, whichever makes more sense or is more convenient. It is generally acceptable to float outputs, unless the part is a transceiver. If the transceiver has an output enable pin, it disables the output section of the part when asserted. This does not disable the input section of the I/Os, so they cannot float when disabled.

8.4.2 Layout Example



图 8-3. Diagram for Unused Inputs

9 Device and Documentation Support

9.1 接收文档更新通知

要接收文档更新通知，请导航至 ti.com 上的器件产品文件夹。点击 [通知](#) 进行注册，即可每周接收产品信息更改摘要。有关更改的详细信息，请查看任何已修订文档中包含的修订历史记录。

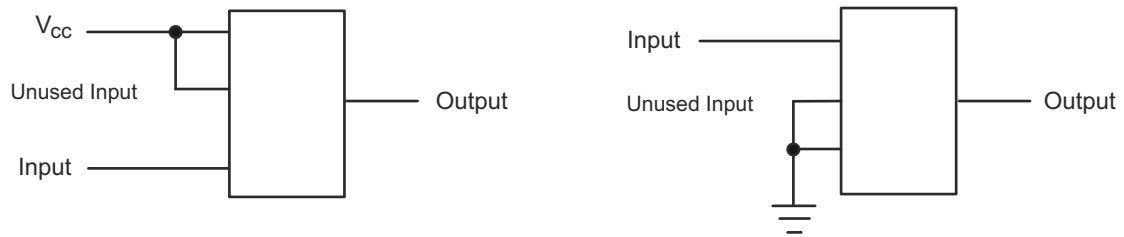
9.2 支持资源

[TI E2E™ 中文支持论坛](#) 是工程师的重要参考资料，可直接从专家处获得快速、经过验证的解答和设计帮助。搜索现有解答或提出自己的问题，获得所需的快速设计帮助。

链接的内容由各个贡献者“按原样”提供。这些内容并不构成 TI 技术规范，并且不一定反映 TI 的观点；请参阅 TI 的 [使用条款](#)。

9.3 Trademarks

TI E2E™ is a trademark of Texas Instruments.
所有商标均为其各自所有者的财产。

9.4 静电放电警告



静电放电 (ESD) 会损坏这个集成电路。德州仪器 (TI) 建议通过适当的预防措施处理所有集成电路。如果不遵守正确的处理和安装程序，可能会损坏集成电路。

ESD 的损坏小至导致微小的性能降级，大至整个器件故障。精密的集成电路可能更容易受到损坏，这是因为非常细微的参数更改都可能会导致器件与其发布的规格不相符。

9.5 术语表

[TI 术语表](#) 本术语表列出并解释了术语、首字母缩略词和定义。

10 Revision History

注：以前版本的页码可能与当前版本的页码不同

Changes from Revision I (May 2024) to Revision J (August 2024)	Page
• Added Settling Time plots.....	9

Changes from Revision H (January 2020) to Revision I (May 2024)	Page
• 更改了封装信息表以包含封装引线.....	1
• 通篇更改了表格、图和交叉参考的编号格式.....	1
• 删除了数据表中的 J (CDIP, 14) 封装.....	1
• Changed max and typ IDD for lower supply voltages.....	5
• Changed VIL from 2V to 1V across supply.....	5

Changes from Revision G (June 2017) to Revision H (January 2020)	Page
• Added Junction Temperature details to the <i>Absolute Maximum Ratings</i> table.....	4

11 Mechanical, Packaging, and Orderable Information

The following pages include mechanical, packaging, and orderable information. This information is the most current data available for the designated devices. This data is subject to change without notice and revision of this document. For browser-based versions of this data sheet, refer to the left-hand navigation.

PACKAGING INFORMATION

Orderable part number	Status (1)	Material type (2)	Package Pins	Package qty Carrier	RoHS (3)	Lead finish/ Ball material (4)	MSL rating/ Peak reflow (5)	Op temp (°C)	Part marking (6)
CD4066BE	Active	Production	PDIP (N) 14	25 TUBE	Yes	NIPDAU	N/A for Pkg Type	-55 to 125	CD4066BE
CD4066BE.A	Active	Production	PDIP (N) 14	25 TUBE	Yes	NIPDAU	N/A for Pkg Type	-55 to 125	CD4066BE
CD4066BF	Active	Production	CDIP (J) 14	25 TUBE	No	SNPB	N/A for Pkg Type	-55 to 125	CD4066BF
CD4066BF.A	Active	Production	CDIP (J) 14	25 TUBE	No	SNPB	N/A for Pkg Type	-55 to 125	CD4066BF
CD4066BF3A	Active	Production	CDIP (J) 14	25 TUBE	No	SNPB	N/A for Pkg Type	-55 to 125	CD4066BF3A
CD4066BF3A.A	Active	Production	CDIP (J) 14	25 TUBE	No	SNPB	N/A for Pkg Type	-55 to 125	CD4066BF3A
CD4066BM	Obsolete	Production	SOIC (D) 14	-	-	Call TI	Call TI	-55 to 125	CD4066BM
CD4066BM96	Active	Production	SOIC (D) 14	2500 LARGE T&R	Yes	NIPDAU	Level-1-260C-UNLIM	-55 to 125	CD4066BM
CD4066BM96.A	Active	Production	SOIC (D) 14	2500 LARGE T&R	Yes	NIPDAU	Level-1-260C-UNLIM	-55 to 125	CD4066BM
CD4066BM96G4	Obsolete	Production	SOIC (D) 14	-	-	Call TI	Call TI	-55 to 125	CD4066BM
CD4066BMT	Obsolete	Production	SOIC (D) 14	-	-	Call TI	Call TI	-55 to 125	CD4066BM
CD4066BNS	Obsolete	Production	SOP (NS) 14	-	-	Call TI	Call TI	-55 to 125	CD4066B
CD4066BNSR	Active	Production	SOP (NS) 14	2000 LARGE T&R	Yes	NIPDAU	Level-1-260C-UNLIM	-55 to 125	CD4066B
CD4066BNSR.A	Active	Production	SOP (NS) 14	2000 LARGE T&R	Yes	NIPDAU	Level-1-260C-UNLIM	-55 to 125	CD4066B
CD4066BPW	Obsolete	Production	TSSOP (PW) 14	-	-	Call TI	Call TI	-55 to 125	CM066B
CD4066BPWR	Active	Production	TSSOP (PW) 14	2000 LARGE T&R	Yes	NIPDAU	Level-1-260C-UNLIM	-55 to 125	CM066B
CD4066BPWR.A	Active	Production	TSSOP (PW) 14	2000 LARGE T&R	Yes	NIPDAU	Level-1-260C-UNLIM	-55 to 125	CM066B
CD4066BPWRG4	Obsolete	Production	TSSOP (PW) 14	-	-	Call TI	Call TI	-55 to 125	CM066B
JM38510/05852BCA	Active	Production	CDIP (J) 14	25 TUBE	No	SNPB	N/A for Pkg Type	-55 to 125	JM38510/ 05852BCA
JM38510/05852BCA.A	Active	Production	CDIP (J) 14	25 TUBE	No	SNPB	N/A for Pkg Type	-55 to 125	JM38510/ 05852BCA
M38510/05852BCA	Active	Production	CDIP (J) 14	25 TUBE	No	SNPB	N/A for Pkg Type	-55 to 125	JM38510/ 05852BCA

(1) **Status:** For more details on status, see our [product life cycle](#).

(2) **Material type:** When designated, preproduction parts are prototypes/experimental devices, and are not yet approved or released for full production. Testing and final process, including without limitation quality assurance, reliability performance testing, and/or process qualification, may not yet be complete, and this item is subject to further changes or possible discontinuation. If available for ordering, purchases will be subject to an additional waiver at checkout, and are intended for early internal evaluation purposes only. These items are sold without warranties of any kind.

(3) **RoHS values:** Yes, No, RoHS Exempt. See the [TI RoHS Statement](#) for additional information and value definition.

(4) **Lead finish/Ball material:** Parts may have multiple material finish options. Finish options are separated by a vertical ruled line. Lead finish/Ball material values may wrap to two lines if the finish value exceeds the maximum column width.

(5) **MSL rating/Peak reflow:** The moisture sensitivity level ratings and peak solder (reflow) temperatures. In the event that a part has multiple moisture sensitivity ratings, only the lowest level per JEDEC standards is shown. Refer to the shipping label for the actual reflow temperature that will be used to mount the part to the printed circuit board.

(6) **Part marking:** There may be an additional marking, which relates to the logo, the lot trace code information, or the environmental category of the part.

Multiple part markings will be inside parentheses. Only one part marking contained in parentheses and separated by a "~" will appear on a part. If a line is indented then it is a continuation of the previous line and the two combined represent the entire part marking for that device.

Important Information and Disclaimer: The information provided on this page represents TI's knowledge and belief as of the date that it is provided. TI bases its knowledge and belief on information provided by third parties, and makes no representation or warranty as to the accuracy of such information. Efforts are underway to better integrate information from third parties. TI has taken and continues to take reasonable steps to provide representative and accurate information but may not have conducted destructive testing or chemical analysis on incoming materials and chemicals. TI and TI suppliers consider certain information to be proprietary, and thus CAS numbers and other limited information may not be available for release.

In no event shall TI's liability arising out of such information exceed the total purchase price of the TI part(s) at issue in this document sold by TI to Customer on an annual basis.

OTHER QUALIFIED VERSIONS OF CD4066B, CD4066B-MIL :

- Catalog : [CD4066B](#)
- Automotive : [CD4066B-Q1](#), [CD4066B-Q1](#)
- Military : [CD4066B-MIL](#)

NOTE: Qualified Version Definitions:

- Catalog - TI's standard catalog product
- Automotive - Q100 devices qualified for high-reliability automotive applications targeting zero defects
- Military - QML certified for Military and Defense Applications

TAPE AND REEL INFORMATION

QUADRANT ASSIGNMENTS FOR PIN 1 ORIENTATION IN TAPE

*All dimensions are nominal

Device	Package Type	Package Drawing	Pins	SPQ	Reel Diameter (mm)	Reel Width W1 (mm)	A0 (mm)	B0 (mm)	K0 (mm)	P1 (mm)	W (mm)	Pin1 Quadrant
CD4066BM96	SOIC	D	14	2500	330.0	16.4	6.5	9.0	2.1	8.0	16.0	Q1
CD4066BM96	SOIC	D	14	2500	330.0	16.4	6.5	9.0	2.1	8.0	16.0	Q1
CD4066BNSR	SOP	NS	14	2000	330.0	16.4	8.1	10.4	2.5	12.0	16.0	Q1
CD4066BPWR	TSSOP	PW	14	2000	330.0	12.4	6.9	5.6	1.6	8.0	12.0	Q1

TAPE AND REEL BOX DIMENSIONS



*All dimensions are nominal

Device	Package Type	Package Drawing	Pins	SPQ	Length (mm)	Width (mm)	Height (mm)
CD4066BM96	SOIC	D	14	2500	353.0	353.0	32.0
CD4066BM96	SOIC	D	14	2500	353.0	353.0	32.0
CD4066BNSR	SOP	NS	14	2000	353.0	353.0	32.0
CD4066BPWR	TSSOP	PW	14	2000	353.0	353.0	32.0

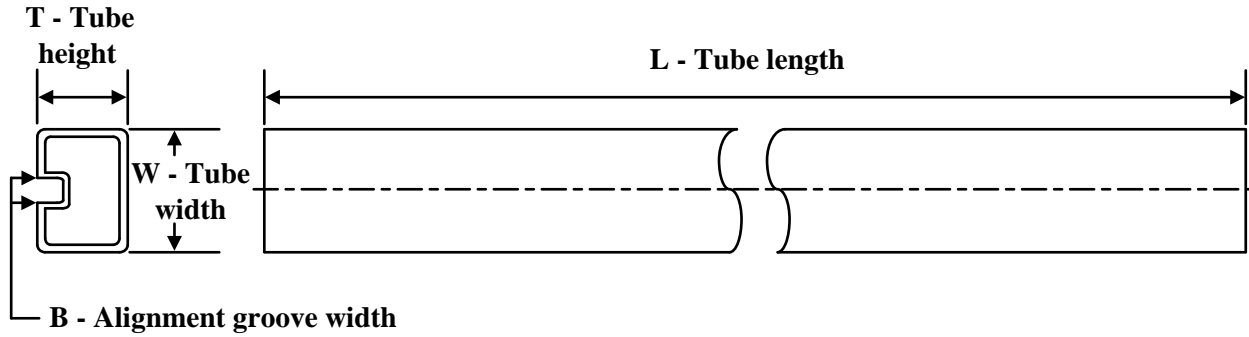
TUBE

*All dimensions are nominal

Device	Package Name	Package Type	Pins	SPQ	L (mm)	W (mm)	T (μm)	B (mm)
CD4066BE	N	PDIP	14	25	506	13.97	11230	4.32
CD4066BE.A	N	PDIP	14	25	506	13.97	11230	4.32

D0014A



PACKAGE OUTLINE

SOIC - 1.75 mm max height

SMALL OUTLINE INTEGRATED CIRCUIT

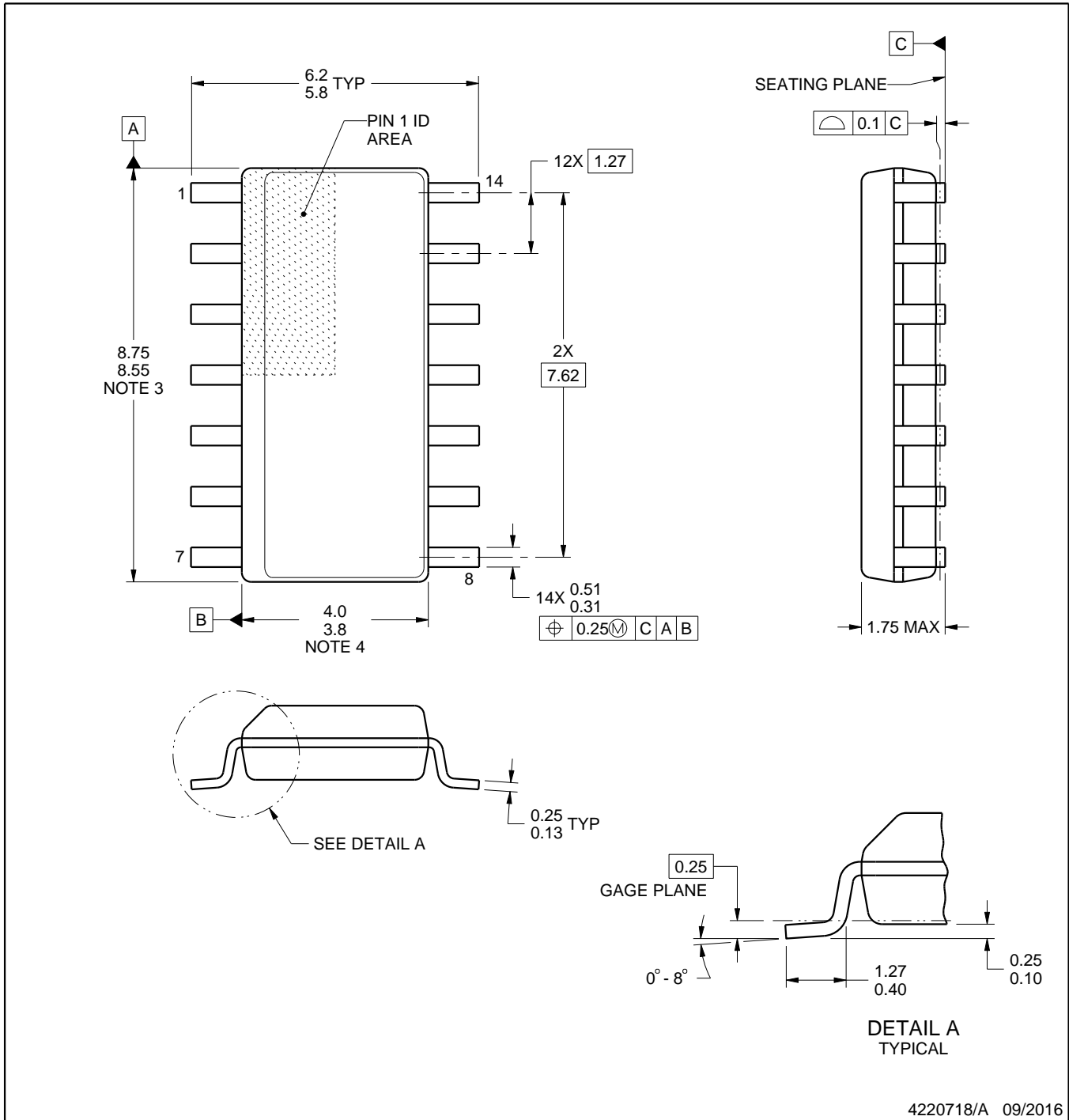

NOTES:

1. All linear dimensions are in millimeters. Dimensions in parenthesis are for reference only. Dimensioning and tolerancing per ASME Y14.5M.
2. This drawing is subject to change without notice.
3. This dimension does not include mold flash, protrusions, or gate burrs. Mold flash, protrusions, or gate burrs shall not exceed 0.15 mm, per side.
4. This dimension does not include interlead flash. Interlead flash shall not exceed 0.43 mm, per side.
5. Reference JEDEC registration MS-012, variation AB.

EXAMPLE BOARD LAYOUT

D0014A

SOIC - 1.75 mm max height

SMALL OUTLINE INTEGRATED CIRCUIT



LAND PATTERN EXAMPLE
SCALE:8X



SOLDER MASK DETAILS

4220718/A 09/2016

NOTES: (continued)

- 6. Publication IPC-7351 may have alternate designs.
- 7. Solder mask tolerances between and around signal pads can vary based on board fabrication site.

EXAMPLE STENCIL DESIGN

D0014A

SOIC - 1.75 mm max height

SMALL OUTLINE INTEGRATED CIRCUIT



SOLDER PASTE EXAMPLE
BASED ON 0.125 mm THICK STENCIL
SCALE:8X

4220718/A 09/2016

NOTES: (continued)

8. Laser cutting apertures with trapezoidal walls and rounded corners may offer better paste release. IPC-7525 may have alternate design recommendations.
9. Board assembly site may have different recommendations for stencil design.

MECHANICAL DATA

NS (R-PDSO-G**)

PLASTIC SMALL-OUTLINE PACKAGE

14-PINS SHOWN



- NOTES:
- A. All linear dimensions are in millimeters.
 - B. This drawing is subject to change without notice.
 - C. Body dimensions do not include mold flash or protrusion, not to exceed 0,15.

J 14

GENERIC PACKAGE VIEW
CDIP - 5.08 mm max height
CERAMIC DUAL IN LINE PACKAGE

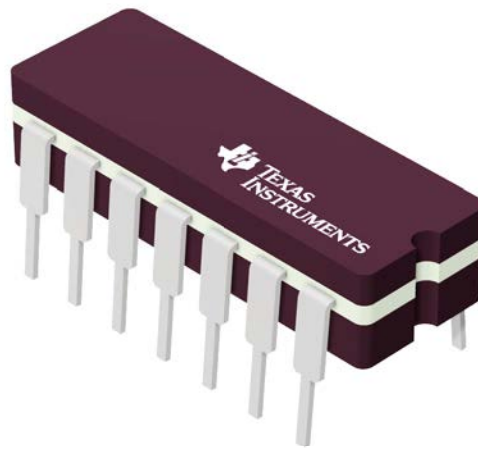

Images above are just a representation of the package family, actual package may vary.
Refer to the product data sheet for package details.

4040083-5/G

J0014A

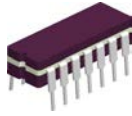

PACKAGE OUTLINE

CDIP - 5.08 mm max height

CERAMIC DUAL IN LINE PACKAGE

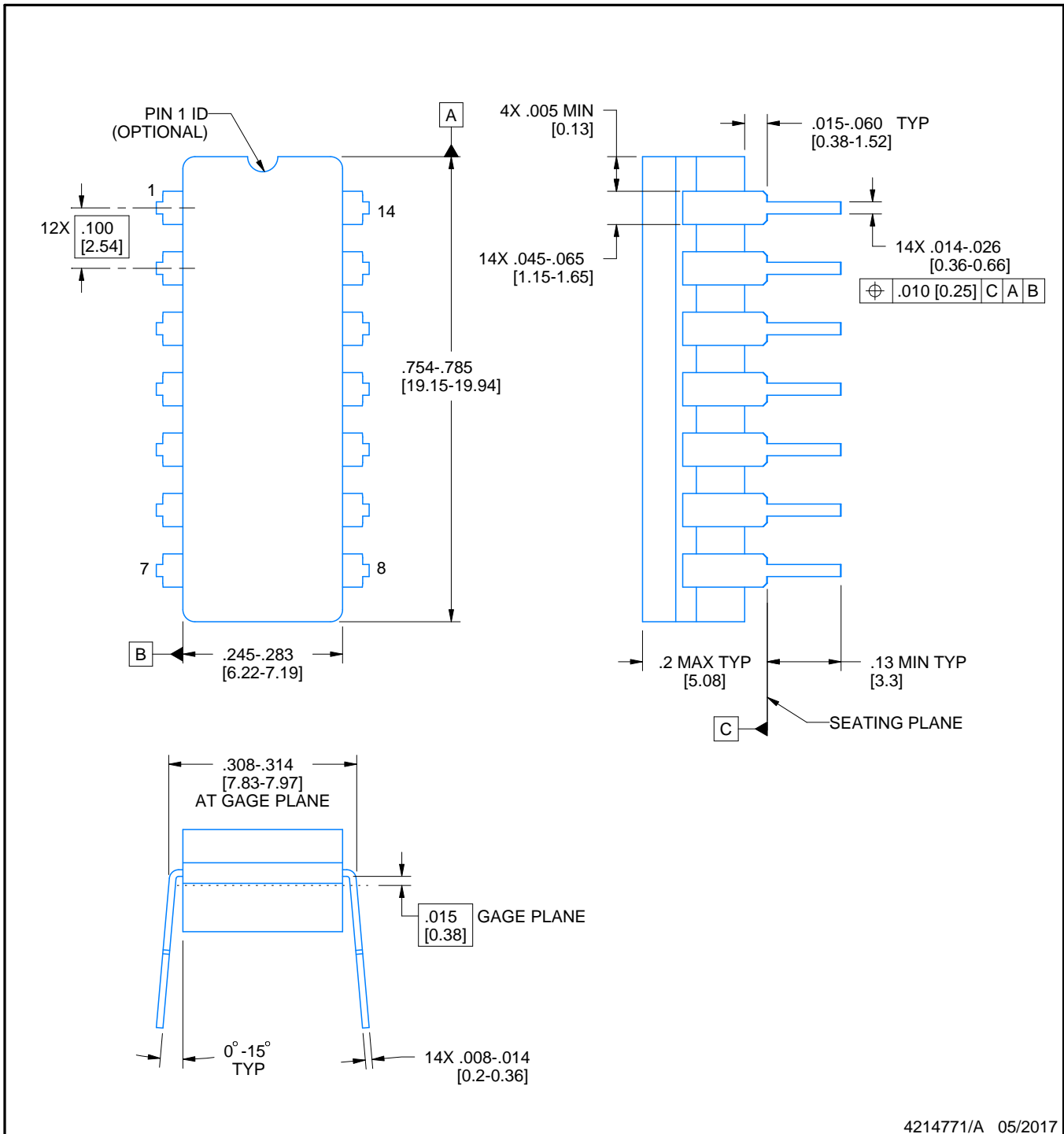

4214771/A 05/2017

NOTES:

1. All controlling linear dimensions are in inches. Dimensions in brackets are in millimeters. Any dimension in brackets or parenthesis are for reference only. Dimensioning and tolerancing per ASME Y14.5M.
2. This drawing is subject to change without notice.
3. This package is hermetically sealed with a ceramic lid using glass frit.
4. Index point is provided on cap for terminal identification only and on press ceramic glass frit seal only.
5. Falls within MIL-STD-1835 and GDIP1-T14.

EXAMPLE BOARD LAYOUT

J0014A

CDIP - 5.08 mm max height

CERAMIC DUAL IN LINE PACKAGE



LAND PATTERN EXAMPLE
NON-SOLDER MASK DEFINED
SCALE: 5X

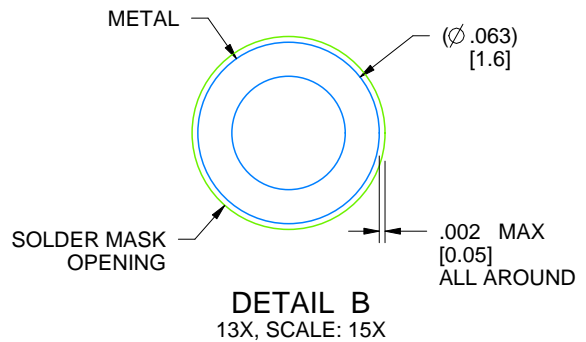
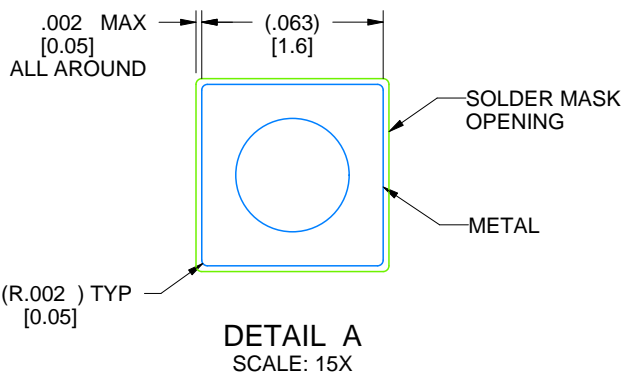

4214771/A 05/2017

N (R-PDIP-T**)

PLASTIC DUAL-IN-LINE PACKAGE

16 PINS SHOWN



- NOTES:
- A. All linear dimensions are in inches (millimeters).
 - B. This drawing is subject to change without notice.
 - Falls within JEDEC MS-001, except 18 and 20 pin minimum body length (Dim A).
 - The 20 pin end lead shoulder width is a vendor option, either half or full width.

PW0014A



PACKAGE OUTLINE

TSSOP - 1.2 mm max height

SMALL OUTLINE PACKAGE



4220202/B 12/2023

NOTES:

1. All linear dimensions are in millimeters. Any dimensions in parenthesis are for reference only. Dimensioning and tolerancing per ASME Y14.5M.
2. This drawing is subject to change without notice.
3. This dimension does not include mold flash, protrusions, or gate burrs. Mold flash, protrusions, or gate burrs shall not exceed 0.15 mm per side.
4. This dimension does not include interlead flash. Interlead flash shall not exceed 0.25 mm per side.
5. Reference JEDEC registration MO-153.

EXAMPLE BOARD LAYOUT

PW0014A

TSSOP - 1.2 mm max height

SMALL OUTLINE PACKAGE

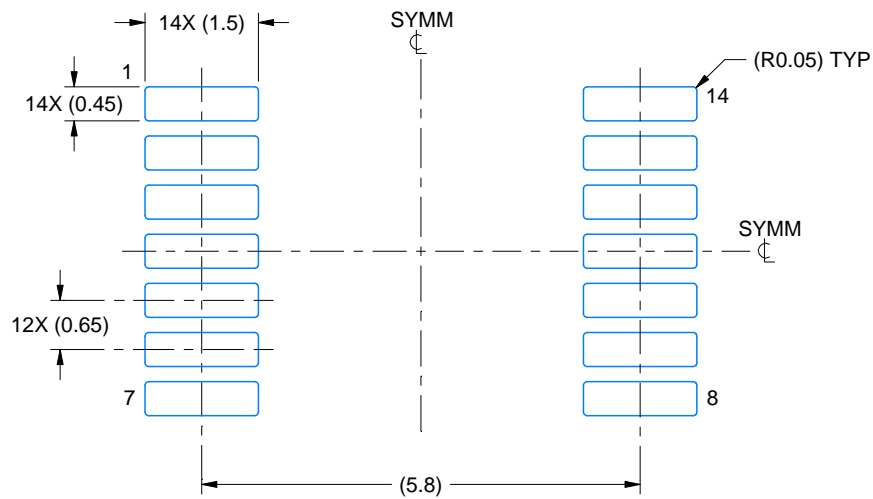

LAND PATTERN EXAMPLE
EXPOSED METAL SHOWN
SCALE: 10X

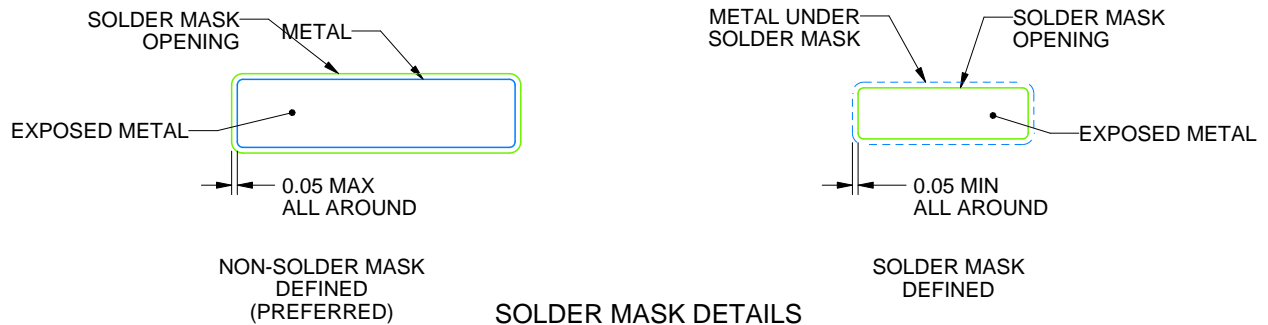

4220202/B 12/2023

NOTES: (continued)

6. Publication IPC-7351 may have alternate designs.
7. Solder mask tolerances between and around signal pads can vary based on board fabrication site.

EXAMPLE STENCIL DESIGN

PW0014A

TSSOP - 1.2 mm max height

SMALL OUTLINE PACKAGE

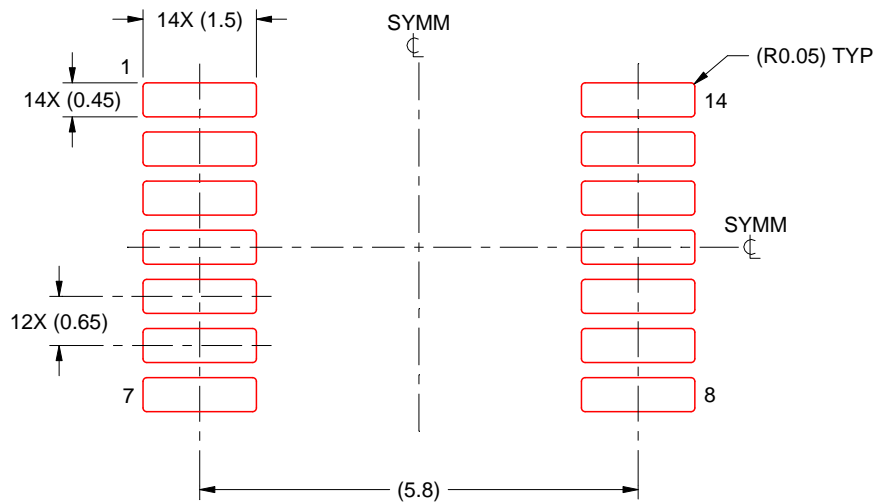

SOLDER PASTE EXAMPLE
BASED ON 0.125 mm THICK STENCIL
SCALE: 10X

4220202/B 12/2023

NOTES: (continued)

8. Laser cutting apertures with trapezoidal walls and rounded corners may offer better paste release. IPC-7525 may have alternate design recommendations.
9. Board assembly site may have different recommendations for stencil design.

重要通知和免责声明

TI“按原样”提供技术和可靠性数据（包括数据表）、设计资源（包括参考设计）、应用或其他设计建议、网络工具、安全信息和其他资源，不保证没有瑕疵且不做任何明示或暗示的担保，包括但不限于对适销性、与某特定用途的适用性或不侵犯任何第三方知识产权的暗示担保。

这些资源可供使用 TI 产品进行设计的熟练开发人员使用。您将自行承担以下全部责任：(1) 针对您的应用选择合适的 TI 产品，(2) 设计、验证并测试您的应用，(3) 确保您的应用满足相应标准以及任何其他安全、安保法规或其他要求。

这些资源如有变更，恕不另行通知。TI 授权您仅可将这些资源用于研发本资源所述的 TI 产品的相关应用。严禁以其他方式对这些资源进行复制或展示。您无权使用任何其他 TI 知识产权或任何第三方知识产权。对于因您对这些资源的使用而对 TI 及其代表造成的任何索赔、损害、成本、损失和债务，您将全额赔偿，TI 对此概不负责。

TI 提供的产品受 [TI 销售条款](#)、[TI 通用质量指南](#) 或 [ti.com](#) 上其他适用条款或 TI 产品随附的其他适用条款的约束。TI 提供这些资源并不会扩展或以其他方式更改 TI 针对 TI 产品发布的适用的担保或担保免责声明。除非德州仪器 (TI) 明确将某产品指定为定制产品或客户特定产品，否则其产品均为按确定价格收入目录的标准通用器件。

TI 反对并拒绝您可能提出的任何其他或不同的条款。

版权所有 © 2026，德州仪器 (TI) 公司

最后更新日期：2025 年 10 月