

Parallel RTC With CPU Supervisor

Features

- Real-Time Clock counts seconds through years in BCD format
- On-chip battery-backup switchover circuit with nonvolatile control for external SRAM
- Less than 500nA of clock operation current in backup mode
- Microprocessor reset valid to $V_{CC} = V_{SS}$
- Independent watchdog timer with a programmable time-out period
- Power-fail interrupt warning
- Programmable clock alarm interrupt active in battery-backup mode
- Programmable periodic interrupt
- Battery-low warning

General Description

The bq4845 Real-Time Clock is a low-power microprocessor peripheral that integrates a time-of-day clock, a 100-year calendar, and a CPU supervisor in a 28-pin SOIC or DIP. The bq4845 is ideal for fax machines, copiers, industrial control systems, point-of-sale terminals, data loggers, and computers.

The bq4845 provides direct connections for a 32.768KHz quartz crystal and a 3V backup battery. Through the use of the conditional chip enable output (\overline{CE}_{OUT}) and battery voltage output (V_{OUT}) pins, the bq4845 can write-protect and make nonvolatile external SRAMs. The backup cell powers the real-time clock and maintains SRAM information in the absence of system voltage.

The bq4845 contains a temperature-compensated reference and comparator circuit that monitors the status of its voltage supply. When the bq4845 de-

tects an out-of-tolerance condition, it generates an interrupt warning and subsequently a microprocessor reset. The reset stays active for 200ms after V_{CC} rises within tolerance, to allow for power supply and processor stabilization.

The bq4845 also has a built-in watchdog timer to monitor processor operation. If the microprocessor does not toggle the watchdog input (\overline{WDI}) within the programmed time-out period, the bq4845 asserts \overline{WDO} and \overline{RST} . \overline{WDI} unconnected disables the watchdog timer.

The bq4845 can generate other interrupts based on a clock alarm condition or a periodic setting. The alarm interrupt can be set to occur from once per second to once per month. The alarm can be made active in the battery-backup mode to serve as a system wake-up call. For interrupts at a rate beyond once per second, the periodic interrupt can be programmed with periods of 30.5 μ s to 500ms.

Pin Connections

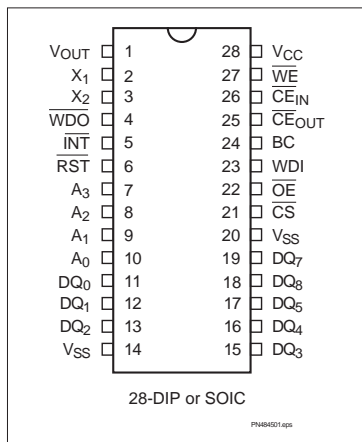

Pin Names

A_0 – A_3	Clock/control address inputs	\overline{BC}	Backup battery input
DQ_0 – DQ_7	Data inputs/outputs	V_{OUT}	Back-up battery output
\overline{WE}	Write enable	\overline{INT}	Interrupt output
\overline{OE}	Output enable	\overline{RST}	Microprocessor reset
\overline{CS}	Chip select input	\overline{WDI}	Watchdog input
\overline{CE}_{IN}	External RAM chip enable	\overline{WDO}	Watchdog output
\overline{CE}_{OUT}	Conditional RAM chip enable	V_{CC}	+5V supply
X_1 – X_2	Crystal inputs	V_{SS}	Ground

bq4845/bq4845Y

Functional Description

power-on reset timing, watchdog timer activation, and interrupt generation.

Figure 1 is a block diagram of the bq4845. The following sections describe the bq4845 functional operation including clock interface, data-retention modes,

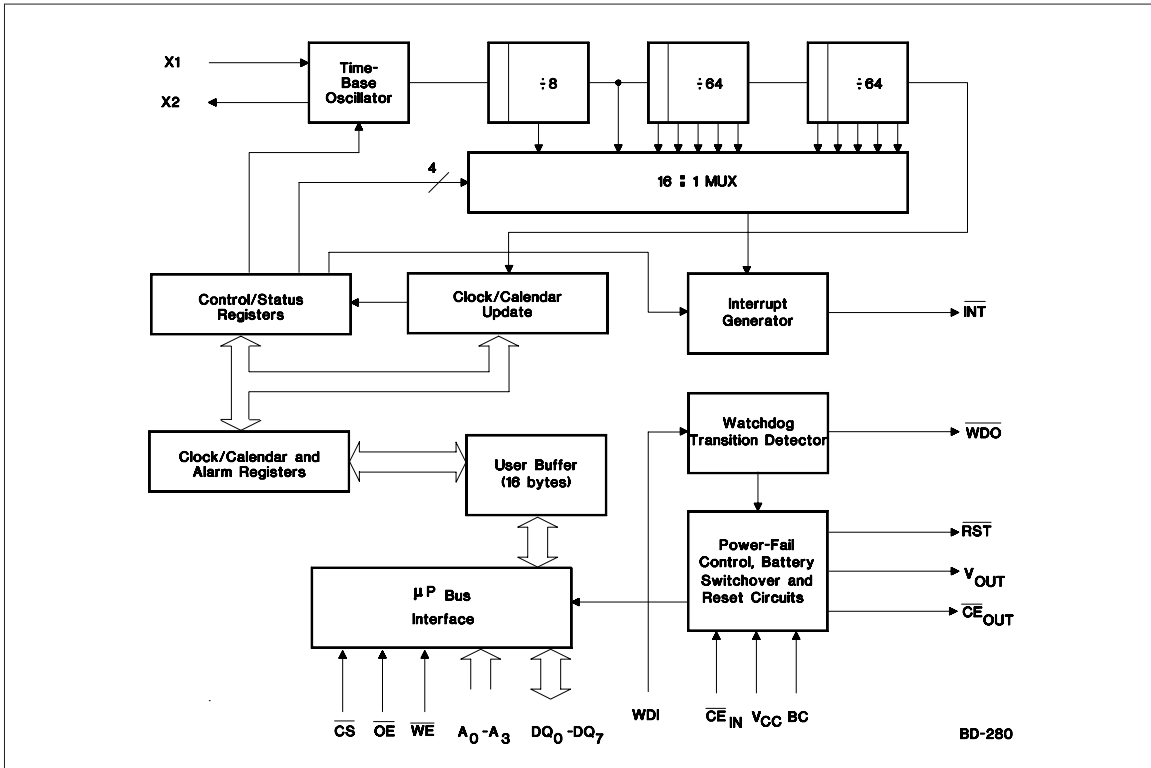

Figure 1. Block Diagram

Truth Table

V _{CC}	\overline{CS}	\overline{OE}	\overline{WE}	\overline{CE}_{OUT}	V _{OUT}	Mode	DQ	Power
< V _{CC} (max.)	V _{IH}	X	X	\overline{CE}_{IN}	V _{OUT1}	Deselect	High Z	Standby
	V _{IL}	X	V _{IL}	\overline{CE}_{IN}	V _{OUT1}	Write	D _{IN}	Active
> V _{CC} (min.)	V _{IL}	V _{IL}	V _{IH}	\overline{CE}_{IN}	V _{OUT1}	Read	D _{OUT}	Active
	V _{IL}	V _{IH}	V _{IH}	\overline{CE}_{IN}	V _{OUT1}	Read	High Z	Active
< V _{PF} D (min.) > V _{SO}	X	X	X	V _{OH}	V _{OUT1}	Deselect	High Z	CMOS standby
≤ V _{SO}	X	X	X	V _{OH} B	V _{OUT2}	Deselect	High Z	Battery-backup mode

Pin Descriptions

X1-X2 Crystal inputs

X1-X2 are a direct connection for a 32.768kHz, 6pF crystal.

$\overline{\text{RST}}$ Reset output

$\overline{\text{RST}}$ goes low whenever V_{CC} falls below the power fail threshold. $\overline{\text{RST}}$ will remain low for 200ms typical after V_{CC} crosses the threshold on power-up. $\overline{\text{RST}}$ also goes low whenever a watchdog timeout occurs. $\overline{\text{RST}}$ is an open-drain output.

$\overline{\text{INT}}$ Interrupt output

$\overline{\text{INT}}$ goes low when a power fail, periodic, or alarm condition occurs. $\overline{\text{INT}}$ is an open-drain output.

WDI Watchdog input

WDI is a three-level input. If WDI remains either high or low for longer than the watchdog time-out period (1.5 seconds default), $\overline{\text{WDO}}$ goes low. $\overline{\text{WDO}}$ remains low until the next transition at WDI. Leaving WDI unconnected disables the watchdog function. WDI connects to an internal voltage divider between V_{OUT} and V_{SS} , which sets it to mid-supply when left unconnected.

$\overline{\text{WDO}}$ Watchdog output

$\overline{\text{WDO}}$ goes low if WDI remains either high or low longer than the watchdog time-out period. $\overline{\text{WDO}}$ returns high on the next transition at WDI. $\overline{\text{WDO}}$ remains high if WDI is unconnected.

A₀-A₃ Clock address inputs

A₀-A₃ allow access to the 16 bytes of real-time clock and control registers.

DQ₀-DQ₇ Data input and output

DQ₀-DQ₇ provide x8 data for real-time clock information. These pins connect to the memory data bus.

V_{SS} Ground

$\overline{\text{CS}}$ Chip select

$\overline{\text{OE}}$ Output enable

$\overline{\text{OE}}$ provides the read control for the RTC memory locations.

$\overline{\text{CE}}_{OUT}$ Chip enable output

$\overline{\text{CE}}_{OUT}$ goes low only when $\overline{\text{CE}}_{IN}$ is low and V_{CC} is above the power fail threshold. If $\overline{\text{CE}}_{IN}$ is low, and power fail occurs, $\overline{\text{CE}}_{OUT}$ stays low for 100 μ s or until $\overline{\text{CE}}_{IN}$ goes high, whichever occurs first.

$\overline{\text{CE}}_{IN}$ Chip enable input

$\overline{\text{CE}}_{IN}$ is the input to the chip-enable gating circuit.

BC Backup battery input

BC should be connected to a 3V backup cell. A voltage within the V_{BC} range on the BC pin should be present upon power up to provide proper oscillator start-up.

V_{OUT} Output supply voltage

V_{OUT} provides the higher of V_{CC} or V_{BC} , switched internally, to supply external RAM.

$\overline{\text{WE}}$ Write enable

$\overline{\text{WE}}$ provides the write control for the RTC memory locations.

V_{CC} Input supply voltage

+5V input

bq4845/bq4845Y

Address Map

The bq4845 provides 16 bytes of clock and control status registers. Table 1 is a map of the bq4845 registers, and Table 2 describes the register bits.

Clock Memory Interface

The bq4845 has the same interface for clock/calendar and control information as standard SRAM. To read and write to these locations, the user must put the bq4845 in the proper mode and meet the timing requirements.

Read Mode

The bq4845 is in read mode whenever \overline{OE} (Output enable) is low and \overline{CS} (chip select) is low. The unique address, specified by the 4 address inputs, defines which one of the 16 clock/calendar bytes is to be accessed. The bq4845 makes valid data available at the data I/O pins within t_{AA} (address access time). This occurs after the last address input signal is stable, and providing the \overline{CS} and \overline{OE} (output enable) access times are met. If the \overline{CS} and \overline{OE} access times are not met, valid data is available after the latter of chip select access time (t_{ACS}) or output enable access time (t_{OE}).

\overline{CS} and \overline{OE} control the state of the eight three-state data I/O signals. If the outputs are activated before t_{AA} ,

Table 1. bq4845 Clock and Control Register Map

Ad- dress (h)	D7	D6	D5	D4	D3	D2	D1	D0	12-Hour Range (h)	Register	
0	0	10-second digit			1-second digit				00–59	Seconds	
1	ALM1	ALM0				1-second digit				00–59	Seconds alarm
		10-second digit									
2	0	10-minute digit			1-minute digit				00–59	Minutes	
3	ALM1	ALM0				1-minute digit				00–59	Minutes alarm
		10-minute digit									
4	PM/AM	0	10-hour digit			1-hour digit				01–12 AM/ 81– 92 PM	Hours
5	ALM1	ALM0	10-hour digit			1-hour digit				01–12 AM/ 81–92 PM	Hours alarm
	PM/AM										
6	0	0	10-day digit			1-day digit				01–31	Day
7	ALM1	ALM0	10-day digit			1-day digit				01–31	Day alarm
8	0	0			0	Day-of-week digit				01–07	Day-of-week
9	0	0	0	10 mo.	1-month digit				01–12	Month	
A	10-year digit				1-year digit				00–99	Year	
B	*	WD2	WD1	WD0	RS3	RS2	RS1	RS0		Programmable rates	
C	*	*			AIE	PIE	PWRIE	ABE		Interrupt enables	
D	*	*			AF	PF	PWRF	BVF		Flags	
E	*	*			UTI	\overline{STOP}	24/12	DSE		Control	
F	*	*	*	*	*	*	*	*		Unused	

Notes: * = Unused bits; unwritable and read as 0.
 0 = should be set to 0 for valid time/calendar range.
 Clock calendar data in BCD. Automatic leap year adjustment.
 PM/AM = 1 for PM; PM/AM = 0 for AM.
 DSE = 1 enables daylight savings adjustment.
 24/12 = 1 enables 24-hour data representation; 24/12 = 0 enables 12-hour data representation.
 Day-of-Week coded as Sunday = 1 through Saturday = 7.
 BVF = 1 for valid battery.
 \overline{STOP} = 1 turns the RTC on; \overline{STOP} = 0 stops the RTC in back-up mode.

Table 2. Clock and Control Register Bits

Bits	Description
24/12	24- or 12-hour representation
ABE	Alarm interrupt enable in battery-backup mode
AF	Alarm interrupt flag
AIE	Alarm interrupt enable
ALM0–ALM1	Alarm mask bits
BVF	Battery-valid flag
DSE	Daylight savings time enable
PF	Periodic interrupt flag
PIE	Periodic interrupt enable
PM/AM	PM or AM indication
PWRF	Power-fail interrupt flag
PWRIE	Power-fail interrupt enable
RS0–RS3	Periodic interrupt rate
$\overline{\text{STOP}}$	Oscillator stop and start
UTI	Update transfer inhibit
WD0 - WD2	Watchdog time-out rate

the data lines are driven to an indeterminate state until t_{AA} . If the address inputs are changed while $\overline{\text{CS}}$ and $\overline{\text{OE}}$ remain low, output data remains valid for t_{OH} (output data hold time), but goes indeterminate until the next address access.

Write Mode

The bq4845 is in write mode whenever $\overline{\text{WE}}$ and $\overline{\text{CS}}$ are active. The start of a write is referenced from the latter-occurring falling edge of $\overline{\text{WE}}$ or $\overline{\text{CS}}$. A write is terminated by the earlier rising edge of $\overline{\text{WE}}$ or $\overline{\text{CS}}$. The addresses must be held valid throughout the cycle. $\overline{\text{CS}}$ or $\overline{\text{WE}}$ must return high for a minimum of t_{WR2} from $\overline{\text{CS}}$ or t_{WR1} from $\overline{\text{WE}}$ prior to the initiation of another read or write cycle.

Data-in must be valid t_{DW} prior to the end of write and remain valid for t_{DH1} or t_{DH2} afterward. $\overline{\text{OE}}$ should be kept high during write cycles to avoid bus contention; although, if the output bus has been activated by a low on $\overline{\text{CS}}$ and $\overline{\text{OE}}$, a low on $\overline{\text{WE}}$ disables the outputs t_{WZ} after $\overline{\text{WE}}$ falls.

Reading the Clock

Once every second, the user-accessible clock/calendar locations are updated simultaneously from the internal real time counters. To prevent reading data in transition, updates to the bq4845 clock registers should be halted. Updating is halted by setting the update transfer inhibit (UTI) bit D3 of the control register E. As long as the UTI bit is 1, updates to user-accessible clock locations are inhibited. Once the frozen clock information is retrieved by reading the appropriate clock memory locations, the UTI bit should be reset to 0 in order to allow updates to occur from the internal counters. Because the internal counters are not halted by setting the UTI bit, reading the clock locations has no effect on clock accuracy. Once the UTI bit is reset to 0, the internal registers update within one second the user-accessible registers with the correct time. A halt command issued during a clock update allows the update to occur before freezing the data.

Setting the Clock

The UTI bit must also be used to set the bq4845 clock. Once set, the locations can be written with the desired information in BCD format. Resetting the UTI bit to 0 causes the written values to be transferred to the internal clock counters and allows updates to the user-accessible registers to resume within one second.

Stopping and Starting the Clock Oscillator

The bq4845 clock can be programmed to turn off when the part goes into battery back-up mode by setting $\overline{\text{STOP}}$ to 0 prior to power down. If the board using the bq4845 is to spend a significant period of time in storage, the $\overline{\text{STOP}}$ bit can be used to preserve some battery capacity. $\overline{\text{STOP}}$ set to 1 keeps the clock running when V_{CC} drops below V_{SO} . With V_{CC} greater than V_{SO} , the bq4845 clock runs regardless of the state of $\overline{\text{STOP}}$.

Power-Down/Power-Up Cycle

The bq4845 continuously monitors V_{CC} for out-of-tolerance. During a power failure, when V_{CC} falls below V_{PFD} , the bq4845 write-protects the clock and storage registers. When V_{CC} is below V_{BC} (3V typical), the power source is switched to BC. RTC operation and storage data are sustained by a valid backup energy source. When V_{CC} is above V_{BC} , the power source is V_{CC} . Write-protection continues for t_{CSR} time after V_{CC} rises above V_{PFD} .

An external CMOS static RAM is battery-backed using the V_{OUT} and chip enable output pins from the bq4845. As the voltage input V_{CC} slews down during a power failure, the chip enable output, $\overline{\text{CE}}_{OUT}$, is forced inactive independent of the chip enable input $\overline{\text{CE}}_{IN}$.

bq4845/bq4845Y

This activity unconditionally write-protects the external SRAM as V_{CC} falls below V_{PFD} . If a memory access is in progress to the external SRAM during power-fail detection, that memory cycle continues to completion before the memory is write-protected. If the memory cycle is not terminated within time t_{WPT} , the chip enable output is unconditionally driven high, write-protecting the controlled SRAM.

As the supply continues to fall past V_{PFD} , an internal switching device forces V_{OUT} to the external backup energy source. \overline{CE}_{OUT} is held high by the V_{OUT} energy source.

During power-up, V_{OUT} is switched back to the 5V supply as V_{CC} rises above the backup cell input voltage sourcing V_{OUT} . \overline{CE}_{OUT} is held inactive for time t_{CER} after the power supply has reached V_{PFD} , independent of the \overline{CE}_{IN} input, to allow for processor stabilization.

During power-valid operation, the \overline{CE}_{IN} input is passed through to the \overline{CE}_{OUT} output with a propagation delay of less than 12ns.

Figure 2 shows the hardware hookup for the external RAM, battery, and crystal.

A primary backup energy source input is provided on the bq4845. The BC input accepts a 3V primary battery, typically some type of lithium chemistry. Since the bq4845 provides for reverse battery charging protection, no diode or current limiting resistor is needed in series with the cell. To prevent battery drain when there is no valid data to retain, V_{OUT} and \overline{CE}_{OUT} are internally isolated from BC by the initial connection of a battery. Following the first application of V_{CC} above V_{PFD} , this isolation is broken, and the backup cell provides power to V_{OUT} and \overline{CE}_{OUT} for the external SRAM.

The crystal should be located as close to X1 and X2 as possible and meet the specifications in the Crystal Specification Table. With the specified crystal, the bq4845 RTC will be accurate to within one minute per month at room temperature. In the absence of a crystal, a 32.768 kHz waveform can be fed into X1 with X2 grounded.

Power-On Reset

The bq4845 provides a power-on reset, which pulls the RST pin low on power-down and remains low on power-up for t_{RST} after V_{CC} passes V_{PFD} . With valid battery voltage on BC, RST remains valid for $V_{CC} = V_{SS}$.

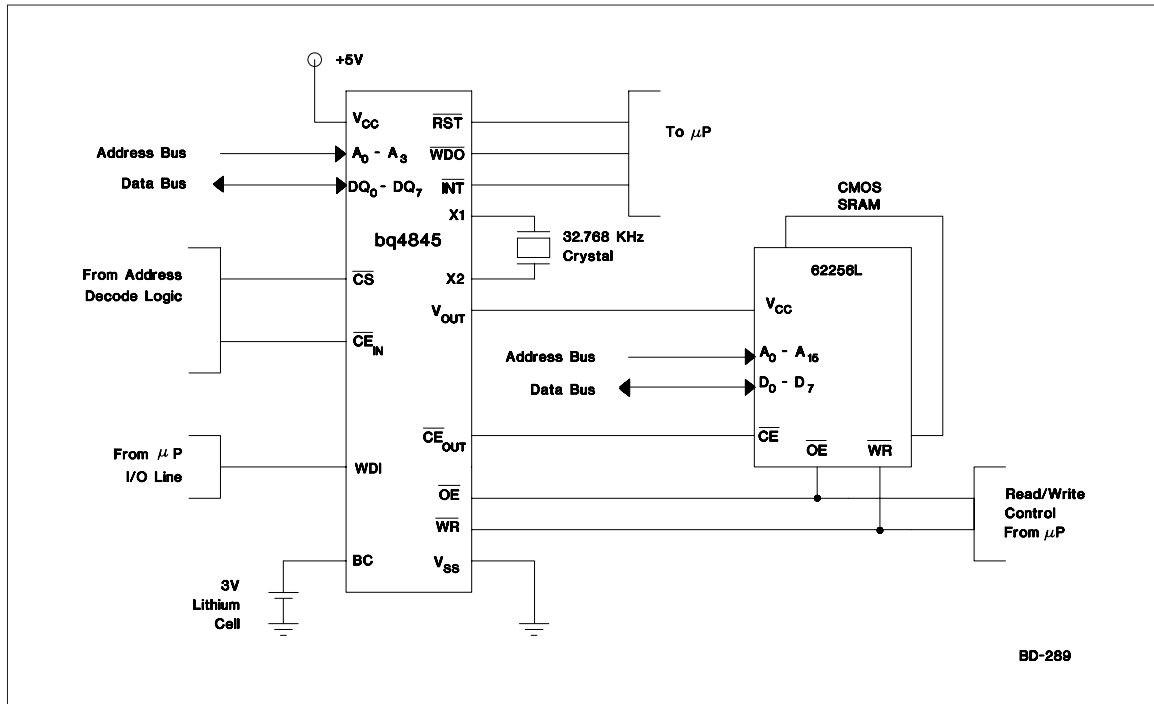

Figure 2. bq4845 Application Circuit

Watchdog Timer

The watchdog monitors microprocessor activity through the Watchdog input (WDI). To use the watchdog function, connect WDI to a bus line or a microprocessor I/O line. If WDI remains high or low for longer than the watchdog time-out period (1.5 seconds default), the bq4845 asserts \overline{WDO} and \overline{RST} .

Watchdog Input

The bq4845 resets the watchdog timer if a change of state (high to low, low to high, or a minimum 100ns pulse) occurs at the Watchdog input (WDI) during the watchdog period. The watchdog time-out is set by WD0-WD2 in register B. The bq4845 maintains the watchdog time-out programming through power cycles. The default state (no valid battery power) of WD0-WD2 is 000 or 1.5s on power-up. Table 3 shows the programmable watchdog time-out rates. The watchdog time-out period immediately after a reset is equal to the programmed watchdog time-out.

To disable the watchdog function, leave WDI floating. An internal resistor network (100k Ω equivalent impedance

at WDI) biases WDI to approximately 1.6V. Internal comparators detect this level and disable the watchdog timer. When V_{CC} is below the power-fail threshold, the bq4845 disables the watchdog function and disconnects WDI from its internal resistor network, thus making it high impedance.

Watchdog Output

The Watchdog output (\overline{WDO}) remains high if there is a transition or pulse at WDI during the watchdog time-out period. The bq4845 disables the watchdog function and \overline{WDO} is a logic high when V_{CC} is below the power fail threshold, battery-backup mode is enabled, or WDI is an open circuit. In watchdog mode, if no transition occurs at WDI during the watchdog time-out period, the bq4845 asserts \overline{RST} for the reset time-out period t_1 . \overline{WDO} goes low and remains low until the next transition at WDI. If WDI is held high or low indefinitely, \overline{RST} will generate pulses (t_1 seconds wide) every t_3 seconds. Figure 3 shows the watchdog timing.

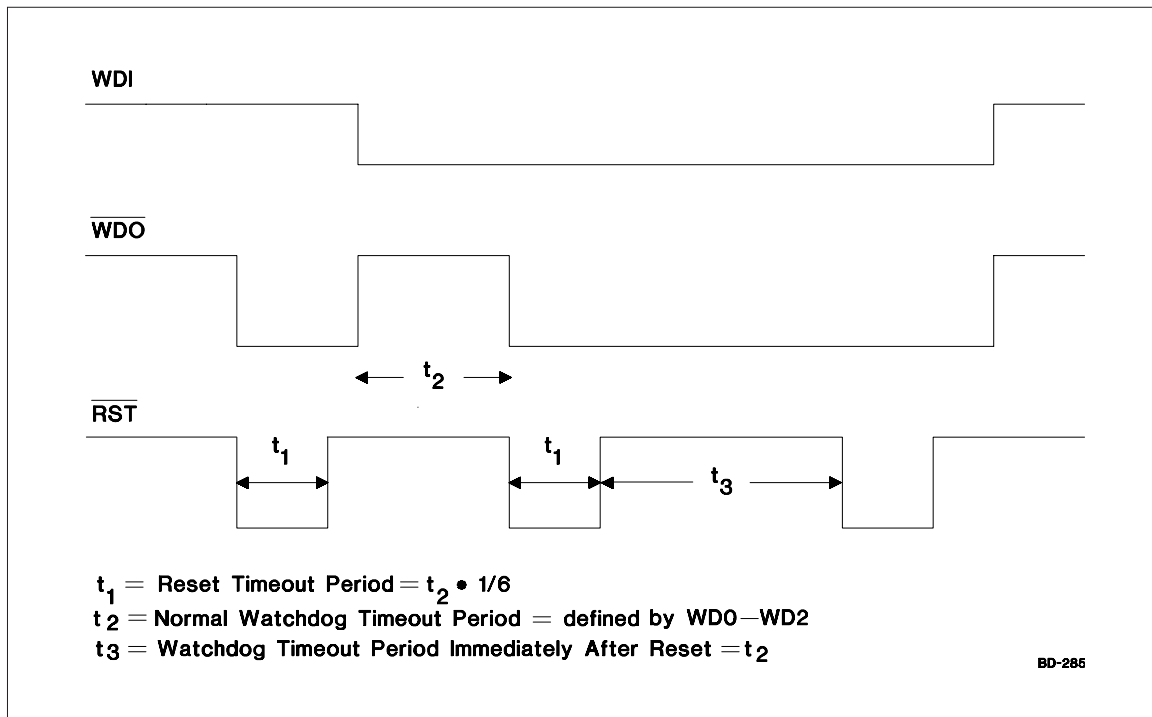

Figure 3. Watchdog Time-out Period and Reset Active Time

bq4845/bq4845Y

Interrupts

The bq4845 allows three individually selected interrupt events to generate an interrupt request on the INT pin. These three interrupt events are:

- The periodic interrupt, programmable to occur once every 30.5µs to 500ms
- The alarm interrupt, programmable to occur once per second to once per month
- The power-fail interrupt, which can be enabled to be asserted when the bq4845 detects a power failure

The periodic, alarm, and power-fail interrupts are enabled by an individual interrupt-enable bit in register C, the interrupts register. When an event occurs, its event flag bit in the flags register, register D, is set. If the corresponding event enable bit is also set, then an interrupt request is generated. Reading the flags register clears all flag bits and makes INT high impedance. To reset the flag register, the bq4845 addresses must be held stable at register D for at least 50ns to avoid inadvertent resets.

Periodic Interrupt

Bits RS3–RS0 in the interrupts register program the rate for the periodic interrupt. The user can interpret the interrupt in two ways: either by polling the flags register for PF assertion or by setting PIE so that INT goes active when the bq4845 sets the periodic flag. Reading the flags register resets the PF bit and returns INT to the high-impedance state. Table 4 shows the periodic rates.

Alarm Interrupt

Registers 1, 3, 5, and 7 program the real-time clock alarm. During each update cycle, the bq4845 compares the date, hours, minutes, and seconds in the clock regis-

ters with the corresponding alarm registers. If a match between all the corresponding bytes is found, the alarm flag AF in the flags register is set. If the alarm interrupt is enabled with AIE, an interrupt request is generated on INT. The alarm condition is cleared by a read to the flags register. ALM1 – ALM0 in the alarm registers, mask each alarm compare byte. An alarm byte is masked by setting ALM1 (D7) and ALM0 (D6) to 1. Alarm byte masking can be used to select the frequency of the alarm interrupt, according to Table 5.

The alarm interrupt can be made active while the bq4845 is in the battery-backup mode by setting ABE in the interrupts register. Normally, the INT pin goes high-impedance during battery backup. With ABE set, however, INT is driven low if an alarm condition occurs and the AIE bit is set. Because the AIE bit is reset during power-on reset, an alarm generated during power-on reset updates only the flags register. The user can read the flags register during boot-up to determine if an alarm was generated during power-on reset.

Power-Fail Interrupt

When VCC falls to the power-fail-detect point, the power-fail flag PWRP is set. If the power-fail interrupt enable bit (PWRIE) is also set, then INT is asserted low. The power-fail interrupt occurs twpr before the bq4845 generates a reset and deselects. The PWRIE bit is cleared on power-up.

Battery-Low Warning

The bq4845 checks the battery on power-up. When the battery voltage is approximately 2.1V, the battery-valid flag BVF in the flags register is set to a 0 indicating that clock and RAM data may be invalid.

Table 3. Watchdog Time-out Rates

WD2	WD1	WD0	Normal Watchdog Time-out Period (t ₂ , t ₃)	Reset Time-out Period (t ₁)
0	0	0	1.5s	0.25s
0	0	1	23.4375ms	3.9063ms
0	1	0	46.875ms	7.8125ms
0	1	1	93.75ms	15.625ms
1	0	0	187.5ms	31.25ms
1	0	1	375ms	62.5ms
1	1	0	750ms	125ms
1	1	1	3s	0.5s

Aug. 1995

Table 4. Periodic Interrupt Rates

Register B Bits				Periodic Interrupt	
RS3	RS2	RS1	RS0	Period	Units
0	0	0	0	None	
0	0	0	1	30.5175	μs
0	0	1	0	61.035	μs
0	0	1	1	122.070	μs
0	1	0	0	244.141	μs
0	1	0	1	488.281	μs
0	1	1	0	976.5625	μs
0	1	1	1	1.95315	ms
1	0	0	0	3.90625	ms
1	0	0	1	7.8125	ms
1	0	1	0	15.625	ms
1	0	1	1	31.25	ms
1	1	0	0	62.5	ms
1	1	0	1	125	ms
1	1	1	0	250	ms
1	1	1	1	500	ms

Table 5. Alarm Frequency (Alarm Bits D6 and D7 of Alarm Registers)

1h	3h	5h	7h	Alarm Frequency
ALM1•ALM0	ALM1•ALM0	ALM1•ALM0	ALM1•ALM0	
1	1	1	1	Once per second
0	1	1	1	Once per minute when seconds match
0	0	1	1	Once per hour when minutes, and seconds match
0	0	0	1	Once per day when hours, minutes, and seconds match
0	0	0	0	When date, hours, minutes, and seconds match

bq4845/bq4845Y

Absolute Maximum Ratings

Symbol	Parameter	Value	Unit	Conditions
V _{CC}	DC voltage applied on V _{CC} relative to V _{SS}	-0.3 to 7.0	V	
V _T	DC voltage applied on any pin excluding V _{CC} relative to V _{SS}	-0.3 to 7.0	V	V _T ≤ V _{CC} + 0.3
T _{OPR}	Operating temperature	0 to +70	°C	Commercial
		-40 to +85	°C	Industrial
T _{STG}	Storage temperature	-55 to +125	°C	
T _{BIAS}	Temperature under bias	-40 to +85	°C	
T _{SOLDER}	Soldering temperature	+260	°C	For 10 seconds

Note: Permanent device damage may occur if **Absolute Maximum Ratings** are exceeded. Functional operation should be limited to the Recommended DC Operating Conditions detailed in this data sheet. Exposure to conditions beyond the operational limits for extended periods of time may affect device reliability.

Recommended DC Operating Conditions (T_A = T_{OPR})

Symbol	Parameter	Minimum	Typical	Maximum	Unit	Notes
V _{CC}	Supply voltage	4.5	5.0	5.5	V	bq4845Y
		4.75	5.0	5.5	V	bq4845
V _{SS}	Supply voltage	0	0	0	V	
V _{IL}	Input low voltage	-0.3	-	0.8	V	
V _{IH}	Input high voltage	2.2	-	V _{CC} + 0.3	V	
V _{BC}	Backup cell voltage	2.3	-	4.0	V	

Note: Typical values indicate operation at T_A = 25°C.

DC Electrical Characteristics ($T_A = T_{OPR}$, $V_{CCmin} \leq V_{CC} \leq V_{CCmax}$)

Symbol	Parameter	Minimum	Typical	Maximum	Unit	Conditions/Notes
I_{LI}	Input leakage current	-	-	± 1	μA	$V_{IN} = V_{SS}$ to V_{CC}
I_{LO}	Output leakage current	-	-	± 1	μA	$\overline{CS} = V_{IH}$ or $\overline{OE} = V_{IH}$ or $\overline{WE} = V_{IL}$
V_{OH}	Output high voltage	2.4	-	-	V	$I_{OH} = -2.0$ mA
V_{OHB}	V_{OH} , BC Supply	$V_{BC} - 0.3$	-	-	V	$V_{BC} > V_{CC}$, $I_{OH} = -10\mu A$
V_{OL}	Output low voltage	-	-	0.4	V	$I_{OL} = 4.0$ mA
I_{CC}	Operating supply current	-	12	25	mA	Min. cycle, duty = 100%, $\overline{CS} = V_{IL}$, $I_{I/O} = 0$ mA
I_{SB1}	Standby supply current	-	3	-	mA	$\overline{CS} = V_{IH}$
I_{SB2}	Standby supply current	-	1.5	-	mA	$\overline{CS} \geq V_{CC} - 0.2$ V, $0V \leq V_{IN} \leq 0.2$ V, or $V_{IN} \geq V_{CC} - 0.2$ V
V_{SO}	Supply switch-over voltage	-	V_{BC}	-	V	
I_{CCB}	Battery operation current	-	0.3	0.5	μA	$V_{BC} = 3$ V, $T_A = 25^\circ C$, no load on V_{OUT} or CE_{OUT}
V_{PFD}	Power-fail-detect voltage	4.55	4.62	4.75	V	bq4845
	Power-fail-detect voltage	4.30	4.37	4.5	V	bq4845Y
V_{OUT1}	V_{OUT} voltage	$V_{CC} - 0.3$ V	-	-	V	$I_{OUT} = 100$ mA, $V_{CC} > V_{BC}$
V_{OUT2}	V_{OUT} voltage	$V_{BC} - 0.3$ V	-	-	V	$I_{OUT} = 100\mu A$, $V_{CC} < V_{BC}$
V_{RST}	\overline{RST} output voltage	-	-	0.4V	-	$I_{RST} = 4$ mA
V_{INT}	\overline{INT} output voltage	-	-	0.4V	-	$I_{INT} = 4$ mA
V_{WDO}	\overline{WDO} output voltage	-	-	0.4V	-	$I_{SINK} = 4$ mA
		2.4	-	-	-	$I_{SOURCE} = 2$ mA
I_{WDIL}	Watchdog input low current	-50	-10	-	μA	$0 < V_{WDI} < 0.8$ V
I_{WDIH}	Watchdog input high current	-	20	50	μA	$2.2 < V_{WDI} < V_{CC}$

Notes: Typical values indicate operation at $T_A = 25^\circ C$, $V_{CC} = 5$ V.
RST and INT are open-drain outputs.

Crystal Specifications (DT-26 or Equivalent)

Symbol	Parameter	Minimum	Typical	Maximum	Unit
f_0	Oscillation frequency	-	32.768	-	kHz
C_L	Load capacitance	-	6	-	pF
T_P	Temperature turnover point	20	25	30	$^\circ C$
k	Parabolic curvature constant	-	-	-0.042	ppm/ $^\circ C$
Q	Quality factor	40,000	70,000	-	
R_1	Series resistance	-	-	45	K Ω
C_0	Shunt capacitance	-	1.1	1.8	pF
C_0/C_1	Capacitance ratio	-	430	600	
D_L	Drive level	-	-	1	μW
$\Delta f/f_0$	Aging (first year at $25^\circ C$)	-	1	-	ppm

bq4845/bq4845Y

Capacitance ($T_A = 25^\circ\text{C}$, $F = 1\text{MHz}$, $V_{CC} = 5.0\text{V}$)

Symbol	Parameter	Minimum	Typical	Maximum	Unit	Conditions
$C_{I/O}$	Input/output capacitance	-	-	7	pF	Output voltage = 0V
C_{IN}	Input capacitance	-	-	5	pF	Input voltage = 0V

Note: These parameters are sampled and not 100% tested.

AC Test Conditions

Parameter	Test Conditions
Input pulse levels	0V to 3.0V
Input rise and fall times	5 ns
Input and output timing reference levels	1.5 V (unless otherwise specified)
Output load (including scope and jig)	See Figures 4 and 5

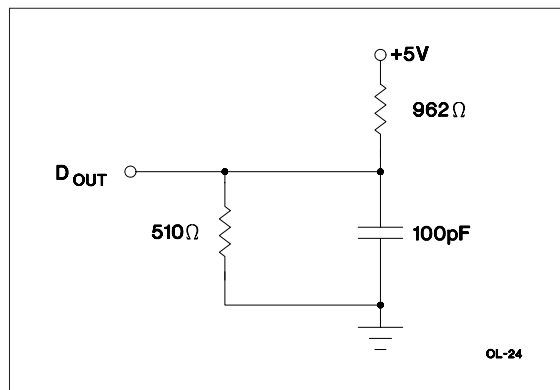

Figure 4. Output Load A

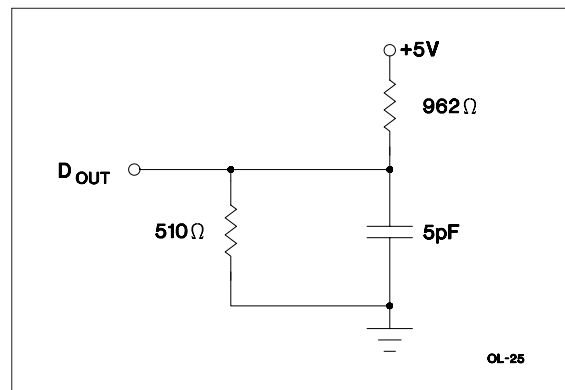

Figure 5. Output Load B

Read Cycle ($T_A = T_{OPR}, V_{CCmin} \leq V_{CC} \leq V_{CCmax}$)

Symbol	Parameter	Min.	Max.	Unit	Conditions
t _{RC}	Read cycle time	70	-	ns	
t _{AA}	Address access time	-	70	ns	Output load A
t _{ACS}	Chip select access time	-	70	ns	Output load A
t _{OE}	Output enable to output valid	-	35	ns	Output load A
t _{CLZ}	Chip select to output in low Z	5	-	ns	Output load B
t _{OLZ}	Output enable to output in low Z	0	-	ns	Output load B
t _{CHZ}	Chip deselect to output in high Z	0	25	ns	Output load B
t _{OHZ}	Output disable to output in high Z	0	25	ns	Output load B
t _{OH}	Output hold from address change	10	-	ns	Output load A

Write Cycle ($T_A = T_{OPR}, V_{CCmin} \leq V_{CC} \leq V_{CCmax}$)

Symbol	Parameter	Min.	Max.	Unit	Conditions
t _{WC}	Write cycle time	70	-	ns	
t _{CW}	Chip select to end of write	65	-	ns	(1)
t _{AW}	Address valid to end of write	65	-	ns	(1)
t _{AS}	Address setup time	0	-	ns	Measured from address valid to beginning of write. (2)
t _{WP}	Write pulse width	55	-	ns	Measured from beginning of write to end of write. (1)
t _{WR1}	Write recovery time (write cycle 1)	5	-	ns	Measured from \overline{WE} going high to end of write cycle. (3)
t _{WR2}	Write recovery time (write cycle 2)	15	-	ns	Measured from \overline{CS} going high to end of write cycle. (3)
t _{DW}	Data valid to end of write	30	-	ns	Measured to first low-to-high transition of either \overline{CS} or \overline{WE} .
t _{DH1}	Data hold time (write cycle 1)	0	-	ns	Measured from \overline{WE} going high to end of write cycle. (4)
t _{DH2}	Data hold time (write cycle 2)	10	-	ns	Measured from \overline{CS} going high to end of write cycle. (4)
t _{WZ}	Write enabled to output in high Z	0	25	ns	I/O pins are in output state. (5)
t _{OW}	Output active from end of write	0	-	ns	I/O pins are in output state. (5)

- Notes:**
1. A write ends at the earlier transition of \overline{CS} going high and \overline{WE} going high.
 2. A write occurs during the overlap of a low \overline{CS} and a low \overline{WE} . A write begins at the later transition of \overline{CS} going low and \overline{WE} going low.
 3. Either t_{WR1} or t_{WR2} must be met.
 4. Either t_{DH1} or t_{DH2} must be met.
 5. If \overline{CS} goes low simultaneously with \overline{WE} going low or after \overline{WE} going low, the outputs remain in high-impedance state.

bq4845/bq4845Y

Read Cycle No. 1 (Address Access) ^{1,2}

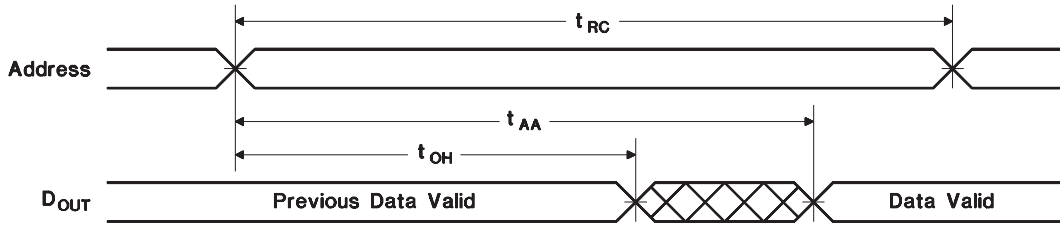

RC-1

Read Cycle No. 2 (CS Access) ^{1,3,4}

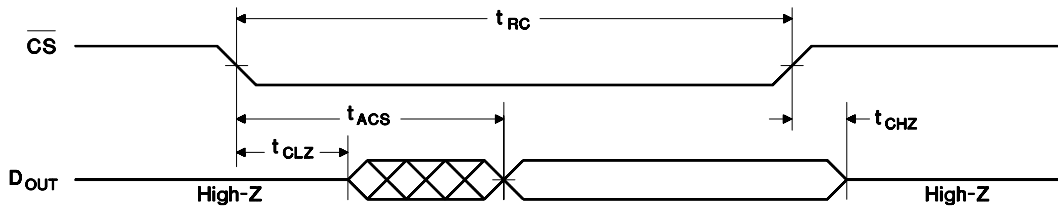

RC-3B

Read Cycle No. 3 (OE Access) ^{1,5}

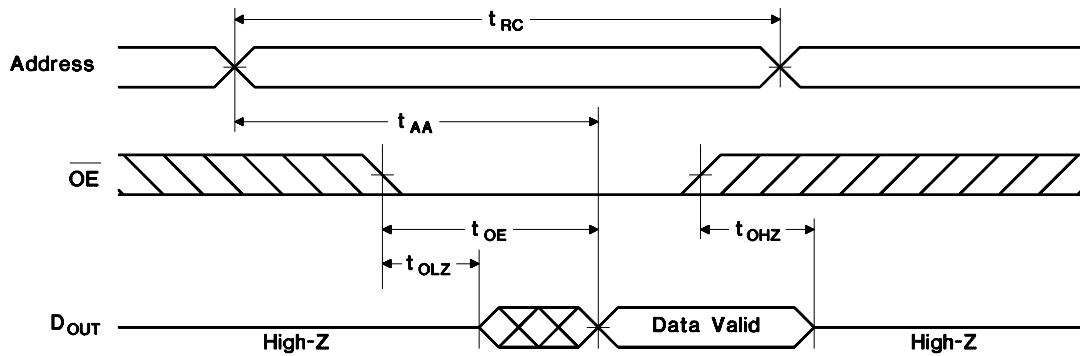

RC-3

- Notes:**
1. \overline{WE} is held high for a read cycle.
 2. Device is continuously selected: $\overline{CS} = \overline{OE} = V_{IL}$.
 3. Address is valid prior to or coincident with \overline{CS} transition low.
 4. $\overline{OE} = V_{IL}$.
 5. Device is continuously selected: $\overline{CS} = V_{IL}$.

Aug. 1995

Write Cycle No. 1 (WE-Controlled) ^{1,2,3}

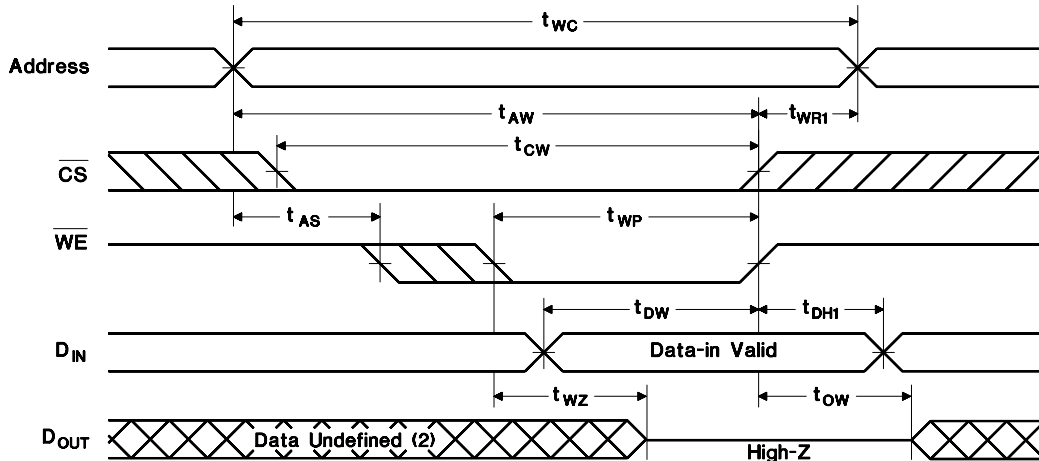

WC-12

Write Cycle No. 2 (CS-Controlled) ^{1,2,3,4,5}

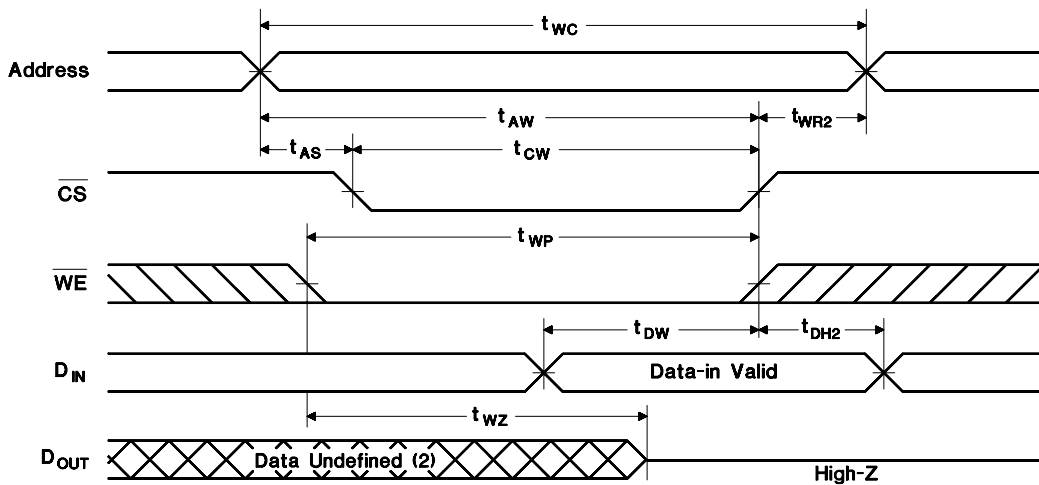

WC-13

- Notes:**
1. \overline{CS} or \overline{WE} must be high during address transition.
 2. Because I/O may be active (\overline{OE} low) during this period, data input signals of opposite polarity to the outputs must not be applied.
 3. If \overline{OE} is high, the I/O pins remain in a state of high impedance.
 4. Either t_{WR1} or t_{WR2} must be met.
 5. Either t_{DH1} or t_{DH2} must be met.

bq4845/bq4845Y

Power-Down/Power-Up Timing (TA = TOPR)

Symbol	Parameter	Minimum	Typical	Maximum	Unit	Conditions
t _F	V _{CC} slew from 4.75 to 4.25V	300	-	-	μs	
t _{FS}	V _{CC} slew from 4.25 to V _{SO}	10	-	-	μs	
t _R	V _{CC} slew from V _{SO} to V _{PFD(MAX)}	100	-	-	μs	
t _{PF}	Interrupt delay from V _{PFD}	6	-	24	μs	
t _{WPT}	Write-protect time for external RAM	90	100	125	μs	Delay after V _{CC} slews down past V _{PFD} before SRAM is write-protected and RST activated.
t _{CSR}	$\overline{\text{CS}}$ at V _{IH} after power-up	100	200	300	ms	Internal write-protection period after V _{CC} passes V _{PFD} on power-up.
t _{RST}	V _{PFD} to $\overline{\text{RST}}$ inactive	t _{CSR}	-	t _{CSR}	ms	Reset active time-out period
t _{CER}	Chip enable recovery time	t _{CSR}	-	t _{CSR}	ms	Time during which external SRAM is write-protected after V _{CC} passes V _{PFD} on power-up.
t _{CED}	Chip enable propagation delay to external SRAM	-	9	12	ns	Output load A

Caution: Negative undershoots below the absolute maximum rating of -0.3V in battery-backup mode may affect data integrity.

Power-Down/Power-Up Timing

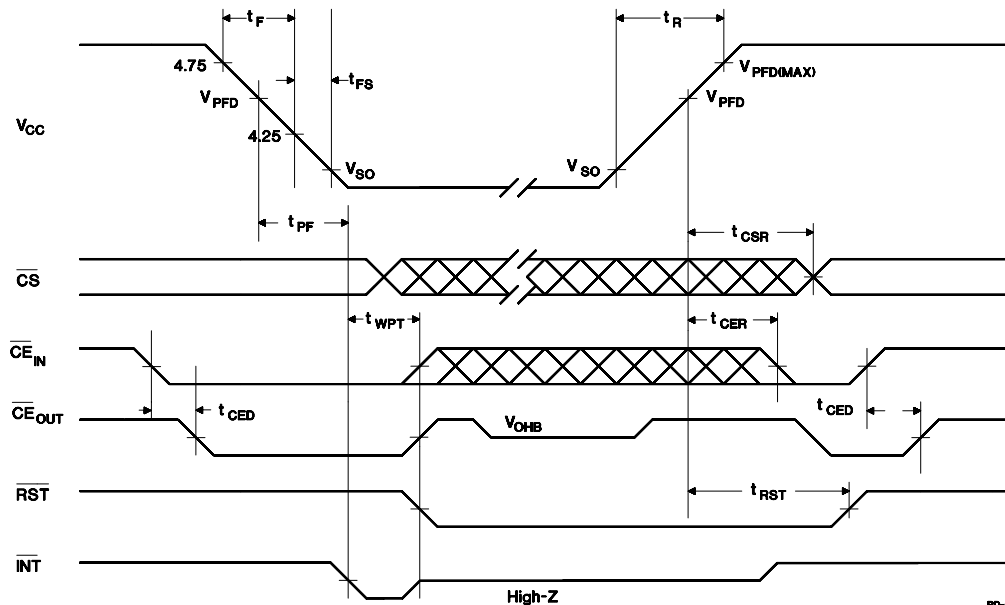

Notes: PWRIE set to "1" to enable power fail interrupt.
RST and INT are open drain and require an external pull-up resistor.

Aug. 1995

28-Pin DIP (P)

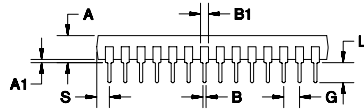
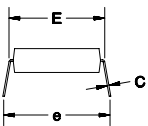
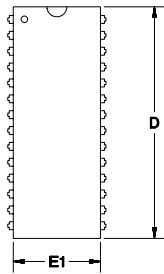

28-Pin DIP (P)

Dimension	Minimum	Maximum
A	0.160	0.190
A1	0.015	0.040
B	0.015	0.022
B1	0.045	0.065
C	0.008	0.013
D	1.440	1.480
E	0.600	0.625
E1	0.530	0.570
e	0.600	0.670
G	0.090	0.110
L	0.115	0.150
S	0.070	0.090

All dimensions are in inches.

bq4845/bq4845Y

28-Pin SOIC (S)

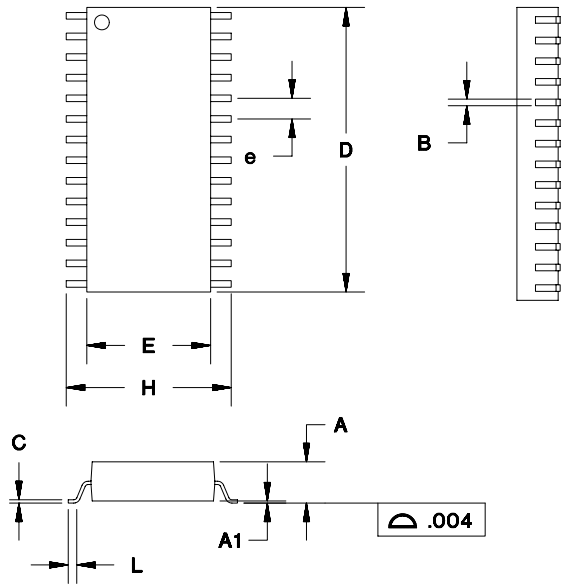

28-Pin SOIC (S)

Dimension	Minimum	Maximum
A	0.095	0.105
A1	0.004	0.012
B	0.013	0.020
C	0.008	0.013
D	0.700	0.715
E	0.290	0.305
e	0.045	0.055
H	0.395	0.415
L	0.020	0.040

All dimensions are in inches.

Ordering Information

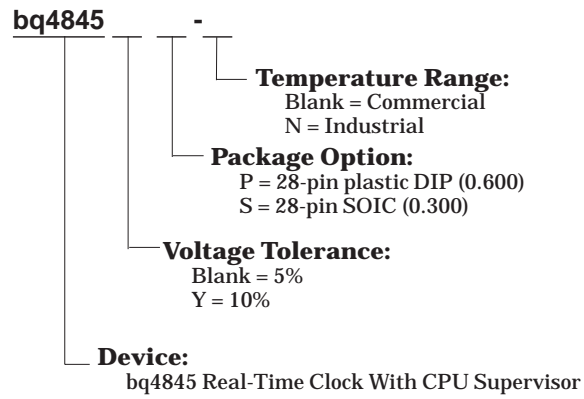

PACKAGING INFORMATION

Orderable part number	Status (1)	Material type (2)	Package Pins	Package qty Carrier	RoHS (3)	Lead finish/ Ball material (4)	MSL rating/ Peak reflow (5)	Op temp (°C)	Part marking (6)
BQ4845S-A4TR	Last Time Buy	Production	SOIC (DW) 28	1000 LARGE T&R	Yes	NIPDAU	Level-1-260C-UNLIM	0 to 70	4845S -A4
BQ4845S-A4TR.B	Last Time Buy	Production	SOIC (DW) 28	1000 LARGE T&R	Yes	NIPDAU	Level-1-260C-UNLIM	0 to 70	4845S -A4

(1) **Status:** For more details on status, see our [product life cycle](#).

(2) **Material type:** When designated, preproduction parts are prototypes/experimental devices, and are not yet approved or released for full production. Testing and final process, including without limitation quality assurance, reliability performance testing, and/or process qualification, may not yet be complete, and this item is subject to further changes or possible discontinuation. If available for ordering, purchases will be subject to an additional waiver at checkout, and are intended for early internal evaluation purposes only. These items are sold without warranties of any kind.

(3) **RoHS values:** Yes, No, RoHS Exempt. See the [TI RoHS Statement](#) for additional information and value definition.

(4) **Lead finish/Ball material:** Parts may have multiple material finish options. Finish options are separated by a vertical ruled line. Lead finish/Ball material values may wrap to two lines if the finish value exceeds the maximum column width.

(5) **MSL rating/Peak reflow:** The moisture sensitivity level ratings and peak solder (reflow) temperatures. In the event that a part has multiple moisture sensitivity ratings, only the lowest level per JEDEC standards is shown. Refer to the shipping label for the actual reflow temperature that will be used to mount the part to the printed circuit board.

(6) **Part marking:** There may be an additional marking, which relates to the logo, the lot trace code information, or the environmental category of the part.

Multiple part markings will be inside parentheses. Only one part marking contained in parentheses and separated by a "-" will appear on a part. If a line is indented then it is a continuation of the previous line and the two combined represent the entire part marking for that device.

Important Information and Disclaimer: The information provided on this page represents TI's knowledge and belief as of the date that it is provided. TI bases its knowledge and belief on information provided by third parties, and makes no representation or warranty as to the accuracy of such information. Efforts are underway to better integrate information from third parties. TI has taken and continues to take reasonable steps to provide representative and accurate information but may not have conducted destructive testing or chemical analysis on incoming materials and chemicals. TI and TI suppliers consider certain information to be proprietary, and thus CAS numbers and other limited information may not be available for release.

In no event shall TI's liability arising out of such information exceed the total purchase price of the TI part(s) at issue in this document sold by TI to Customer on an annual basis.

TAPE AND REEL INFORMATION

QUADRANT ASSIGNMENTS FOR PIN 1 ORIENTATION IN TAPE

*All dimensions are nominal

Device	Package Type	Package Drawing	Pins	SPQ	Reel Diameter (mm)	Reel Width W1 (mm)	A0 (mm)	B0 (mm)	K0 (mm)	P1 (mm)	W (mm)	Pin1 Quadrant
BQ4845S-A4TR	SOIC	DW	28	1000	330.0	32.4	11.35	18.67	3.1	16.0	32.0	Q1

TAPE AND REEL BOX DIMENSIONS

*All dimensions are nominal

Device	Package Type	Package Drawing	Pins	SPQ	Length (mm)	Width (mm)	Height (mm)
BQ4845S-A4TR	SOIC	DW	28	1000	356.0	356.0	53.0

IMPORTANT NOTICE AND DISCLAIMER

TI PROVIDES TECHNICAL AND RELIABILITY DATA (INCLUDING DATASHEETS), DESIGN RESOURCES (INCLUDING REFERENCE DESIGNS), APPLICATION OR OTHER DESIGN ADVICE, WEB TOOLS, SAFETY INFORMATION, AND OTHER RESOURCES "AS IS" AND WITH ALL FAULTS, AND DISCLAIMS ALL WARRANTIES, EXPRESS AND IMPLIED, INCLUDING WITHOUT LIMITATION ANY IMPLIED WARRANTIES OF MERCHANTABILITY, FITNESS FOR A PARTICULAR PURPOSE OR NON-INFRINGEMENT OF THIRD PARTY INTELLECTUAL PROPERTY RIGHTS.

These resources are intended for skilled developers designing with TI products. You are solely responsible for (1) selecting the appropriate TI products for your application, (2) designing, validating and testing your application, and (3) ensuring your application meets applicable standards, and any other safety, security, regulatory or other requirements.

These resources are subject to change without notice. TI grants you permission to use these resources only for development of an application that uses the TI products described in the resource. Other reproduction and display of these resources is prohibited. No license is granted to any other TI intellectual property right or to any third party intellectual property right. TI disclaims responsibility for, and you fully indemnify TI and its representatives against any claims, damages, costs, losses, and liabilities arising out of your use of these resources.

TI's products are provided subject to [TI's Terms of Sale](#), [TI's General Quality Guidelines](#), or other applicable terms available either on ti.com or provided in conjunction with such TI products. TI's provision of these resources does not expand or otherwise alter TI's applicable warranties or warranty disclaimers for TI products. Unless TI explicitly designates a product as custom or customer-specified, TI products are standard, catalog, general purpose devices.

TI objects to and rejects any additional or different terms you may propose.

Copyright © 2026, Texas Instruments Incorporated

Last updated 10/2025