

# bq2407x 1.5A 高电池电压锂离子电池充电器 (具有电源路径管理 IC)

## 1 特性

- 完全符合 USB 充电器标准
  - 最大输入电流可选 100mA 和 500mA
  - 100mA 最大电流限制可确保充电符合 USB-IF 标准
  - 基于输入的动态电源管理 ( $V_{IN-DPM}$ )，用于保护免受不良 USB 电源损害
- 28V 输入额定值，具有过压保护
- 集成的动态电源路径管理 (DPPM) 功能可同时独立进行系统供电和电池充电
- 具有用于进行电流监控的输出 (ISET)，可支持高达 1.5A 的充电电流
- 针对墙式充电器的高达 1.5A 的可编程输入电流限制
- 系统输出跟踪电池电压
- 带有 SYSOFF 输入的电池断开功能。
- 可编程预充电和快速充电安全定时器
- 反向电流、短路和热保护
- 负温度系数 (NTC) 热敏电阻输入
- 专有启动序列可限制浪涌电流
- 电池充电电压  $V_{BAT}$ :
  - bq24076 - 4.4V (典型值)
  - bq24078 - 4.35V (典型值)
- 状态指示 - 正在充电/充电完成，电源正常

## 2 应用范围

- 智能电话
- 便携式媒体播放器
- 便携式导航设备
- 低功耗手持设备
- 便携式游戏机
- 耳机
- 可穿戴设备
- 家庭自动化
- 便携式医疗设备

## 3 说明

bq2407x 是一个集成型锂离子电池线性充电器系列，具有适用于空间受限型便携式应用的系统电源路径管理功能。这类器件通过 USB 端口或交流适配器运行，最高支持 1.5A 的充电电流。它们在输入电压范围内具有输入电压保护功能，因此支持非稳压适配器。bq2407x 的 USB 输入电流限制精度和启动序列使得这款器件能够符合 USB-IF 涌入电流规范。此外，输入动态电源管理 ( $V_{IN-DPM}$ ) 可防止因错误配置 USB 电源而引起的系统崩溃，并且可最大程度地提高能够从适配器中获得的功率。

bq2407x 具有动态电源路径管理 (DPPM) 功能，可在系统供电的同时独立为电池充电。当输入电流限制引起系统输出降至 DPPM 阈值时，DPPM 电路将减少充电电流；因此，可在为系统负载供电时随时监测充电电流。这个特性减少了电池上充放电周期的数量，可实现充电正常终止并使得系统能够在由有缺陷或者不完整的电池组供电的情况下运行。

器件信息<sup>(1)</sup>

| 器件型号    | 封装        | 封装尺寸 (标称值)      |
|---------|-----------|-----------------|
| bq24076 | VQFN (16) | 3.00mm x 3.00mm |
| bq24078 |           |                 |

(1) 如需了解所有可用封装，请参阅数据表末尾的可订购产品附录。

典型应用电路

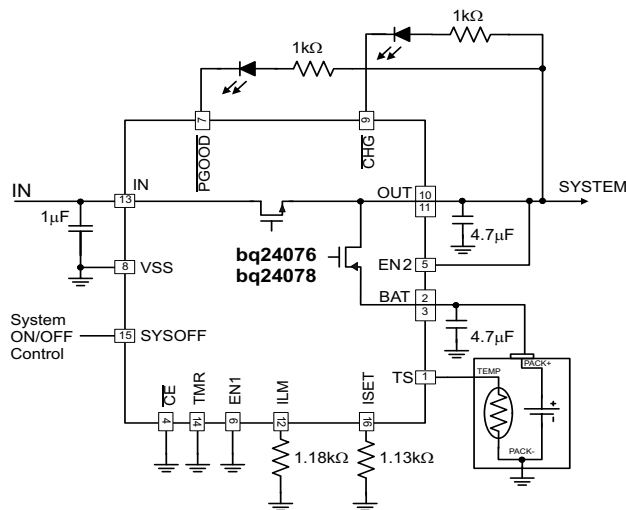

Copyright © 2017, Texas Instruments Incorporated



## 目录

|   |  |
|---|--|
| <p><b>1</b> 特性 ..... 1</p> <p><b>2</b> 应用范围 ..... 1</p> <p><b>3</b> 说明 ..... 1</p> <p><b>4</b> 修订历史记录 ..... 2</p> <p><b>5</b> 说明 (续) ..... 3</p> <p><b>6</b> <b>Device Comparison Table</b> ..... 3</p> <p><b>7</b> <b>Pin Configuration and Functions</b> ..... 4</p> <p><b>8</b> <b>Specifications</b> ..... 5</p> <p style="padding-left: 20px;">8.1 Absolute Maximum Ratings ..... 5</p> <p style="padding-left: 20px;">8.2 ESD Ratings ..... 5</p> <p style="padding-left: 20px;">8.3 Recommended Operating Conditions ..... 6</p> <p style="padding-left: 20px;">8.4 Thermal Information ..... 6</p> <p style="padding-left: 20px;">8.5 Dissipation Ratings ..... 6</p> <p style="padding-left: 20px;">8.6 Electrical Characteristics ..... 7</p> <p style="padding-left: 20px;">8.7 Typical Characteristics ..... 9</p> <p><b>9</b> <b>Detailed Description</b> ..... 11</p> <p style="padding-left: 20px;">9.1 Overview ..... 11</p> <p style="padding-left: 20px;">9.2 Functional Block Diagram ..... 12</p> | <p style="padding-left: 20px;">9.3 Feature Description ..... 13</p> <p style="padding-left: 20px;">9.4 Device Functional Modes ..... 24</p> <p><b>10</b> <b>Application and Implementation</b> ..... 26</p> <p style="padding-left: 20px;">10.1 Application Information ..... 26</p> <p style="padding-left: 20px;">10.2 Typical Application ..... 26</p> <p><b>11</b> <b>Power Supply Recommendations</b> ..... 31</p> <p><b>12</b> <b>Layout</b> ..... 31</p> <p style="padding-left: 20px;">12.1 Layout Guidelines ..... 31</p> <p style="padding-left: 20px;">12.2 Layout Example ..... 32</p> <p style="padding-left: 20px;">12.3 Thermal Considerations ..... 33</p> <p><b>13</b> <b>器件和文档支持</b> ..... 34</p> <p style="padding-left: 20px;">13.1 器件支持 ..... 34</p> <p style="padding-left: 20px;">13.2 相关链接 ..... 34</p> <p style="padding-left: 20px;">13.3 接收文档更新通知 ..... 34</p> <p style="padding-left: 20px;">13.4 社区资源 ..... 34</p> <p style="padding-left: 20px;">13.5 商标 ..... 34</p> <p style="padding-left: 20px;">13.6 静电放电警告 ..... 34</p> <p style="padding-left: 20px;">13.7 Glossary ..... 34</p> <p><b>14</b> <b>机械、封装和可订购信息</b> ..... 34</p> |
|---|--|

## 4 修订历史记录

### Changes from Original (October 2017) to Revision A

Page

- |   |   |
|---|---|
| <ul style="list-style-type: none"> <li>• Changed <math>I_{IN}</math> Test Conditions From: <math>T_J = 85^\circ\text{C}</math> To: <math>T_J &lt; 85^\circ\text{C}</math> in the <i>Electrical Characteristics</i> table ..... 7</li> </ul> | 7 |
|---|---|

## 5 说明（续）

此外，该系列充电器可提供经稳压的系统输入，即使在电池完全放电的情况下，也可使系统在连接电源后实现瞬间开启。当适配器无法提供峰值系统电流时，电源路径管理架构还允许使用电池来补充系统电流，进而支持使用更小的适配器。

电池充电发生于以下三个阶段：调节、恒定电流和恒定电压。在所有的充电阶段，一个内部控制环路监测 IC 结温并且如果超过此内部温度阈值则减少充电电流。充电器功率级和充电电流感应功能完全集成在了一起。该充电器具高精度电流和电压调节环路、充电状态显示和充电终止功能。输入电流限制和充电电流可使用外部电阻编程设定。

## 6 Device Comparison Table

| PART NUMBER <sup>(1)</sup> <sup>(2)</sup> | V <sub>OV</sub> P | V <sub>BAT(REG)</sub> | V <sub>OUT(REG)</sub>     | V <sub>DPPM</sub>            | OPTIONAL FUNCTION |
|---|-------------------|-----------------------|---------------------------|------------------------------|-------------------|
| bq24072                                   | 6.6 V             | 4.2 V                 | V <sub>BAT</sub> + 225 mV | V <sub>O(REG)</sub> – 100 mV | TD                |
| bq24073                                   | 6.6 V             | 4.2 V                 | 4.4 V                     | V <sub>O(REG)</sub> – 100 mV | TD                |
| bq24074                                   | 10.5 V            | 4.2 V                 | 4.4 V                     | V <sub>O(REG)</sub> – 100 mV | ITERM             |
| bq24075                                   | 6.6 V             | 4.2 V                 | 5.5 V                     | 4.3 V                        | SYSOFF            |
| bq24076                                   | 6.6 V             | 4.4 V                 | V <sub>BAT</sub> + 210mV  | V <sub>BAT</sub> +100 mV     | SYSOFF            |
| bq24078                                   | 6.6 V             | 4.35 V                | V <sub>BAT</sub> + 210mV  | V <sub>BAT</sub> +100 mV     | SYSOFF            |
| bq24079                                   | 6.6 V             | 4.1 V                 | 5.5 V                     | 4.3 V                        | SYSOFF            |

(1) For all available packages, see the orderable addendum at the end of the data sheet

(2) This product is RoHS compatible, including a lead concentration that does not exceed 0.1% of total product weight, and is suitable for use in specified lead-free soldering processes. In addition, this product uses package materials that do not contain halogens, including bromine (Br) or antimony (Sb) above 0.1% of total product weight.

## 7 Pin Configuration and Functions

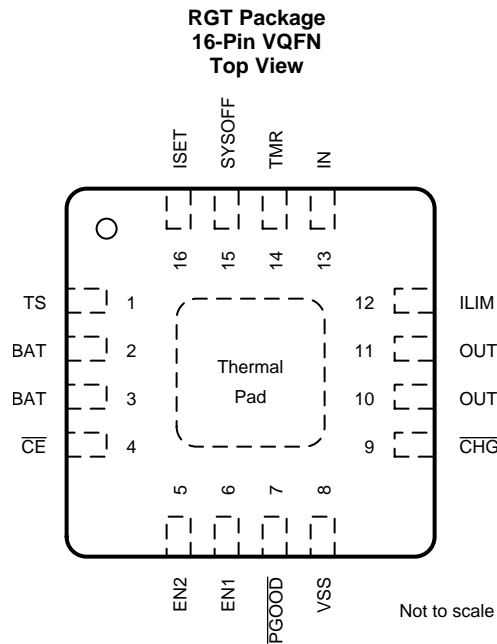

### Pin Functions

| PIN                       |        | I/O | DESCRIPTION  |
|---------------------------|--------|-----|--|
| NAME                      | NO.    |     |  |
| BAT                       | 2, 3   | I/O | Charger Power Stage Output and Battery Voltage Sense Input. Connect BAT to the positive terminal of the battery. Bypass BAT to VSS with a 4.7- $\mu$ F to 47- $\mu$ F ceramic capacitor.   |
| $\overline{\text{CE}}$    | 4      | I   | Charge Enable Active-Low Input. Connect $\overline{\text{CE}}$ to a high logic level to suspend charging. When $\overline{\text{CE}}$ is high, OUT is active and battery supplement mode is still available. Connect $\overline{\text{CE}}$ to a low logic level to enable the battery charger. $\overline{\text{CE}}$ is internally pulled down with approximately 285 k $\Omega$ . Do not leave $\overline{\text{CE}}$ unconnected to ensure proper operation. |
| $\overline{\text{CHG}}$   | 9      | O   | Open-Drain Charging Status Indication Output. $\overline{\text{CHG}}$ pulls to VSS when the battery is charging. $\overline{\text{CHG}}$ is high impedance when charging is complete and when charger is disabled. Connect $\overline{\text{CHG}}$ to the desired logic voltage rail using a 1k $\Omega$ -100k $\Omega$ resistor, or use with an LED for visual indication.  |
| EN1                       | 6      | I   | Input Current Limit Configuration Inputs. Use EN1 and EN2 control the maximum input current and enable USB compliance. See Table 2 for the description of the operation states. EN1 and EN2 are internally pulled down with $\approx$ 285 k $\Omega$ . Do not leave EN1 or EN2 unconnected to ensure proper operation.   |
| EN2                       | 5      | I   |  |
| ILIM                      | 12     | I   | Adjustable Current Limit Programming Input. Connect a 1100- $\Omega$ to 8-k $\Omega$ resistor from ILIM to VSS to program the maximum input current (EN2=1, EN1=0). The input current includes the system load and the battery charge current. Leaving ILIM unconnected disables all charging.   |
| IN                        | 13     | I   | Input Power Connection. Connect IN to the external DC supply (AC adapter or USB port). The input operating range is 4.35 V to 6.6 V (bq24076 and bq24078). The input can accept voltages up to 26 V without damage but operation is suspended. Connect bypass capacitor 1 $\mu$ F to 10 $\mu$ F to VSS.  |
| ISET                      | 16     | I/O | Fast Charge Current Programming Input. Connect a 590- $\Omega$ to 8.9-k $\Omega$ resistor from ISET to VSS to program the fast charge current level. Charging is disabled if ISET is left unconnected. While charging, the voltage at ISET reflects the actual charging current and can be used to monitor charge current. See <a href="#">Charge Current Translator</a> for more details.   |
| OUT                       | 10, 11 | O   | System Supply Output. OUT provides a regulated output when the input is below the OVP threshold and above the regulation voltage. When the input is out of the operation range, OUT is connected to V <sub>BAT</sub> except when SYSOFF is high. Connect OUT to the system load. Bypass OUT to VSS with a 4.7- $\mu$ F to 47- $\mu$ F ceramic capacitor.   |
| $\overline{\text{PGOOD}}$ | 7      | O   | Open-drain Power Good Status Indication Output. $\overline{\text{PGOOD}}$ pulls to VSS when a valid input source is detected. $\overline{\text{PGOOD}}$ is high-impedance when the input power is not within specified limits. Connect $\overline{\text{PGOOD}}$ to the desired logic voltage rail using a 1-k $\Omega$ to 100-k $\Omega$ resistor, or use with an LED for visual indication.  |
| SYSOFF                    | 15     | I   | System Enable Input. Connect SYSOFF high to turn off the FET connecting the battery to the system output. When an adapter is connected, charging is also disabled. Connect SYSOFF low for normal operation. SYSOFF is internally pulled up to V <sub>BAT</sub> through a large resistor (approximately 5 M $\Omega$ ). Do not leave SYSOFF unconnected to ensure proper operation.   |
| Thermal Pad               | –      | –   | There is an internal electrical connection between the exposed thermal pad and the VSS pin of the device. The thermal pad must be connected to the same potential as the VSS pin on the printed circuit board. Do not use the thermal pad as the primary ground input for the device. VSS pin must be connected to ground at all times.  |
| TMR                       | 14     | I   | Timer Programming Input. TMR controls the pre-charge and fast-charge safety timers. Connect TMR to VSS to disable all safety timers. Connect a 18-k $\Omega$ to 72-k $\Omega$ resistor between TMR and VSS to program the timers a desired length. Leave TMR unconnected to set the timers to the default values.  |

### Pin Functions (continued)

| PIN  |     | I/O | DESCRIPTION   |
|------|-----|-----|---|
| NAME | NO. |     |   |
| TS   | 1   | I   | External NTC Thermistor Input. Connect the TS input to the NTC thermistor in the battery pack. TS monitors a 10-kΩ NTC thermistor. For applications that do not use the TS function, connect a 10-kΩ fixed resistor from TS to VSS to maintain a valid voltage level on TS. |
| VSS  | 8   | –   | Ground. Connect to the thermal pad and to the ground rail of the circuit.   |

**Table 1. EN1/EN2 Settings**

| EN2 | EN1 | MAXIMUM INPUT CURRENT INTO IN PIN            |
|-----|-----|--|
| 0   | 0   | 100 mA. USB100 mode                          |
| 0   | 1   | 500 mA. USB500 mode                          |
| 1   | 0   | Set by an external resistor from ILIM to VSS |
| 1   | 1   | Standby (USB suspend mode)                   |

## 8 Specifications

### 8.1 Absolute Maximum Ratings<sup>(1)</sup>

over the 0°C to 125°C operating free-air temperature range (unless otherwise noted)

|                  |                             | MIN   | MAX                | UNIT |   |
|------------------|-----------------------------|---|--------------------|------|---|
| V <sub>I</sub>   | Input Voltage               | IN (with respect to VSS)  | –0.3               | 28   | V |
|                  |                             | BAT (with respect to VSS)   | –0.3               | 5    | V |
|                  |                             | OUT, EN1, EN2, $\overline{CE}$ , TS, ISET, $\overline{PGOOD}$ , $\overline{CHG}$ , ILIM, TMR, ITERM, SYSOFF, TD (with respect to VSS) | –0.3               | 7    | V |
| I <sub>I</sub>   | Input Current               | IN  | 1.6                | A    |   |
| I <sub>O</sub>   | Output Current (Continuous) | OUT   | 5                  | A    |   |
|                  |                             | BAT (Discharge mode)  | 5                  | A    |   |
|                  |                             | BAT (Charging mode)   | 1.5 <sup>(2)</sup> | A    |   |
|                  | Output Sink Current         | $\overline{CHG}$ , $\overline{PGOOD}$   | 15                 | mA   |   |
| T <sub>J</sub>   | Junction temperature        | –40   | 150                | °C   |   |
| T <sub>stg</sub> | Storage temperature         | –65   | 150                | °C   |   |

- (1) Stresses beyond those listed under *Absolute Maximum Ratings* may cause permanent damage to the device. These are stress ratings only, and functional operation of the device at these or any other conditions beyond those indicated under *Recommended Operating Conditions* is not implied. Exposure to absolute-maximum-rated conditions for extended periods may affect device reliability. All voltage values are with respect to the network ground terminal unless otherwise noted.
- (2) The IC operational charging life is reduced to 20,000 hours, when charging at 1.5A and 125°C. The thermal regulation feature reduces charge current if the IC's junction temperature reaches 125°C; thus without a good thermal design the maximum programmed charge current may not be reached.

### 8.2 ESD Ratings

|                    |                         | VALUE  | UNIT  |
|--------------------|-------------------------|--|-------|
| V <sub>(ESD)</sub> | Electrostatic discharge | Human body model (HBM), per ANSI/ESDA/JEDEC JS-001 <sup>(1)</sup>              | ±1500 |
|                    |                         | Charged-device model (CDM), per JEDEC specification JESD22-C101 <sup>(2)</sup> | ±500  |

- (1) JEDEC document JEP155 states that 500-V HBM allows safe manufacturing with a standard ESD control process.
- (2) JEDEC document JEP157 states that 250-V CDM allows safe manufacturing with a standard ESD control process.

### 8.3 Recommended Operating Conditions

|                    |   | MIN  | MAX                | UNIT |
|--------------------|---|------|--------------------|------|
| V <sub>I</sub>     | IN voltage range  | 4.35 | 26                 | V    |
|                    | IN operating voltage range                              | 4.35 | 6.4                | V    |
| I <sub>IN</sub>    | Input current, IN pin                                   |      | 1.5                | A    |
| I <sub>OUT</sub>   | Current, OUT pin  |      | 4.5                | A    |
| I <sub>BAT</sub>   | Current, BAT pin (Discharging)                          |      | 4.5                | A    |
| I <sub>CHG</sub>   | Current, BAT pin (Charging)                             |      | 1.5 <sup>(1)</sup> | A    |
| T <sub>J</sub>     | Junction Temperature                                    | –40  | 125                | °C   |
| R <sub>ILIM</sub>  | Maximum input current programming resistor              | 1100 | 8000               | Ω    |
| R <sub>ISET</sub>  | Fast-charge current programming resistor <sup>(2)</sup> | 590  | 8900               | Ω    |
| R <sub>ITERM</sub> | Termination current programming resistor                | 0    | 15                 | kΩ   |
| R <sub>TMR</sub>   | Timer programming resistor                              | 18   | 72                 | kΩ   |

- (1) The IC operational charging life is reduced to 20,000 hours, when charging at 1.5A and 125°C. The thermal regulation feature reduces charge current if the IC's junction temperature reaches 125°C; thus without a good thermal design the maximum programmed charge current may not be reached.
- (2) Use a 1% tolerance resistor for R<sub>ISET</sub> to avoid issues with the R<sub>ISET</sub> short test when using the maximum charge current setting.

### 8.4 Thermal Information

| THERMAL METRIC <sup>(1)</sup> |  | bq2407x    |  |
|-------------------------------|--|------------|--|
|                               |  | RGT (VQFN) |  |
|                               |  | 16 PIN     |  |
|                               |  | UNIT       |  |
| R <sub>θJA</sub>              | Junction-to-ambient thermal resistance       | 44.5 °C/W  |  |
| R <sub>θJC(top)</sub>         | Junction-to-case (top) thermal resistance    | 54.2 °C/W  |  |
| R <sub>θJB</sub>              | Junction-to-board thermal resistance         | 17.2 °C/W  |  |
| Ψ <sub>JT</sub>               | Junction-to-top characterization parameter   | 1.0 °C/W   |  |
| Ψ <sub>JB</sub>               | Junction-to-board characterization parameter | 17.1 °C/W  |  |
| R <sub>θJC(bot)</sub>         | Junction-to-case (bottom) thermal resistance | 3.8 °C/W   |  |

- (1) For more information about traditional and new thermal metrics, see the [Semiconductor and IC Package Thermal Metrics](#) application report.

### 8.5 Dissipation Ratings

| PACKAGE <sup>(1)</sup> | R <sub>θJA</sub> | R <sub>θJC</sub> | POWER RATING          |                       |
|------------------------|------------------|------------------|-----------------------|-----------------------|
|                        |                  |                  | T <sub>A</sub> ≤ 25°C | T <sub>A</sub> = 85°C |
| RGT <sup>(2)</sup>     | 39.47°C/W        | 2.4°C/W          | 2.3 W                 | 225 mW                |

- (1) For the most current package and ordering information, see the Package Option Addendum at the end of this document, or see the TI website at [www.ti.com](http://www.ti.com).
- (2) This data is based on using the JEDEC High-K board and the exposed die pad is connected to a Cu pad on the board. The pad is connected to the ground plane by a 2 × 3 via matrix.

## 8.6 Electrical Characteristics

Over junction temperature range ( $0^\circ \leq T_J \leq 125^\circ\text{C}$ ) and the recommended supply voltage range (unless otherwise noted)

| PARAMETER  |  | TEST CONDITIONS   | MIN                      | TYP                                  | MAX                      | UNIT          |
|--|--|---|--------------------------|--------------------------------------|--------------------------|---------------|
| <b>INPUT</b>   |  |   |                          |                                      |                          |               |
| UVLO   | Undervoltage lock-out  | $V_{IN}: 0\text{ V} \rightarrow 4\text{ V}$   | 3.2                      | 3.3                                  | 3.4                      | V             |
| $V_{HYS}$  | Hysteresis on UVLO   | $V_{IN}: 4\text{ V} \rightarrow 0\text{ V}$   | 200                      |                                      | 300                      | mV            |
| $V_{IN(DT)}$   | Input power detection threshold  | Input power detected when $V_{IN} > V_{BAT} + V_{IN(DT)}$<br>$V_{BAT} = 3.6\text{ V}$ , $V_{IN}: 3.5\text{ V} \rightarrow 4\text{ V}$ | 55                       | 80                                   | 130                      | mV            |
| $V_{HYS}$  | Hysteresis on $V_{IN(DT)}$   | $V_{BAT} = 3.6\text{ V}$ , $V_{IN}: 4\text{ V} \rightarrow 3.5\text{ V}$  | 20                       |                                      |                          | mV            |
| $t_{DGL(PGOOD)}$   | Deglintch time, input power detected status  | Time measured from $V_{IN}: 0\text{ V} \rightarrow 5\text{ V}$ 1 $\mu\text{s}$ rise-time to PGOOD = LO                                |                          | 1.2                                  |                          | ms            |
| $V_{OVP}$  | Input overvoltage protection threshold   | $V_{IN}: 5\text{ V} \rightarrow 7\text{ V}$   | 6.4                      | 6.6                                  | 6.8                      | V             |
| $V_{HYS}$  | Hysteresis on OVP  | $V_{IN}: 7\text{ V} \rightarrow 5\text{ V}$   |                          | 110                                  |                          | mV            |
| $t_{DGL(OVP)}$   | Input overvoltage blanking time (OVP fault deglitch)   |   |                          | 50                                   |                          | $\mu\text{s}$ |
| $t_{REC}$  | Input overvoltage recovery time  | Time measured from $V_{IN}: 11\text{ V} \rightarrow 5\text{ V}$ with 1 $\mu\text{s}$ fall-time to PGOOD = LO                          |                          | 1.2                                  |                          | ms            |
| <b>ILIM, ISET SHORT-CIRCUIT DETECTION (CHECKED DURING STARTUP)</b> |  |   |                          |                                      |                          |               |
| $I_{SC}$   | Current source   | $V_{IN} > UVLO$ and $V_{IN} > V_{BAT} + V_{IN(DT)}$   |                          | 1.3                                  |                          | mA            |
| $V_{SC}$   |  | $V_{IN} > UVLO$ and $V_{IN} > V_{BAT} + V_{IN(DT)}$   |                          | 520                                  |                          | mV            |
| <b>QUIESCENT CURRENT</b>   |  |   |                          |                                      |                          |               |
| $I_{BAT(PDWN)}$  | Sleep current into BAT pin   | $\overline{CE} = \text{LO}$ or HI, input power not detected, No load on OUT pin, $T_J = 85^\circ\text{C}$                             |                          | 4.1                                  | 7                        | $\mu\text{A}$ |
| $I_{IN}$   | Standby current into IN pin  | EN1= HI, EN2=HI, $V_{IN} = 6\text{ V}$ , $T_J < 85^\circ\text{C}$   |                          | 39                                   | 50                       | $\mu\text{A}$ |
|  |  | EN1= HI, EN2=HI, $V_{IN} = 10\text{ V}$ , $T_J < 85^\circ\text{C}$  |                          | 91                                   | 200                      |               |
| $I_{CC}$   | Active supply current, IN pin  | $\overline{CE} = \text{LO}$ , $V_{IN} = 6\text{ V}$ , no load on OUT pin, $V_{BAT} > V_{BAT(REG)}$ , (EN1, EN2) $\neq$ (HI, HI)       |                          |                                      | 1.5                      | mA            |
| <b>POWER PATH</b>  |  |   |                          |                                      |                          |               |
| $V_{DO(IN-OUT)}$   | $V_{IN} - V_{OUT}$   | $V_{IN} = 4.3\text{ V}$ , $I_{IN} = 1\text{ A}$ , $V_{BAT} = 4.2\text{ V}$  |                          | 300                                  | 475                      | mV            |
| $V_{DO(BAT-OUT)}$  | $V_{BAT} - V_{OUT}$  | $I_{OUT} = 1\text{ A}$ , $V_{IN} = 0\text{ V}$ , $V_{BAT} > 3\text{ V}$   |                          | 50                                   | 100                      | mV            |
| $V_{O(REG)}$   | OUT pin voltage regulation   | $V_{IN} > V_{OUT} + V_{DO(IN-OUT)}$ , $V_{BAT} < 3.2\text{ V}$  | 3.31                     | 3.41                                 | 3.51                     | V             |
|  |  | $V_{IN} > V_{OUT} + V_{DO(IN-OUT)}$ , $V_{BAT} \geq 3.2\text{ V}$   | $V_{BAT} + 145\text{mV}$ | $V_{BAT} + 210\text{mV}$             | $V_{BAT} + 275\text{mV}$ |               |
| $I_{IN(max)}$  | Maximum input current  | EN1 = LO, EN2 = LO  | 90                       | 95                                   | 100                      | mA            |
|  |  | EN1 = HI, EN2 = LO  | 450                      | 475                                  | 500                      |               |
|  |  | EN2 = HI, EN1 = LO  | $K_{LIM}/R_{LIM}$        |                                      |                          |               |
| $K_{LIM}$  | Maximum input current factor   | $I_{LIM} = 500\text{ mA}$ to 1.5 A  | 1500                     | 1610                                 | 1720                     | A $\Omega$    |
|  |  | $I_{LIM} = 200\text{ mA}$ to 500 mA   | 1330                     | 1525                                 | 1720                     |               |
| $I_{IN(max)}$  | Programmable input current limit range   | EN2 = HI, EN1 = LO, $R_{LIM} = 8\text{ k}\Omega$ to 1.1 k $\Omega$  | 200                      |                                      | 1500                     | mA            |
| $V_{IN-DPM}$   | Input voltage threshold when input current is reduced  | EN2 = LO, EN1 = X   | 4.35                     | 4.5                                  | 4.63                     | V             |
| $V_{DPPM}$   | Output voltage threshold when charging current is reduced  |   | $V_{BAT} + 125\text{mV}$ | $V_{BAT} + 100\text{mV}$             | $V_{BAT} + 85\text{mV}$  | V             |
| $V_{BSUP1}$  | Enter battery supplement mode  | $V_{BAT} = 3.6\text{ V}$ , $R_{LIM} = 1.5\text{ k}\Omega$ , $R_{LOAD} = 10\ \Omega \rightarrow 2\ \Omega$                             |                          | $V_{OUT} \leq V_{BAT} - 40\text{mV}$ |                          | V             |
| $V_{BSUP2}$  | Exit battery supplement mode   | $V_{BAT} = 3.6\text{ V}$ , $R_{LIM} = 1.5\text{ k}\Omega$ , $R_{LOAD} = 2\ \Omega \rightarrow 10\ \Omega$                             |                          | $V_{OUT} \geq V_{BAT} - 20\text{mV}$ |                          | V             |
| $V_{O(SC1)}$   | Output short-circuit detection threshold, power-on   | $V_{IN} > V_{UVLO}$ and $V_{IN} > V_{BAT} + V_{IN(DT)}$   | 0.8                      | 0.9                                  | 1                        | V             |
| $V_{O(SC2)}$   | Output short-circuit detection threshold, supplement mode $V_{BAT} - V_{OUT} > V_{O(SC2)}$ indicates short-circuit | $V_{IN} > V_{UVLO}$ and $V_{IN} > V_{BAT} + V_{IN(DT)}$   | 200                      | 250                                  | 300                      | mV            |
| $t_{DGL(SC2)}$   | Deglitch time, supplement mode short circuit   |   |                          | 250                                  |                          | $\mu\text{s}$ |
| $t_{REC(SC2)}$   | Recovery time, supplement mode short circuit   |   |                          | 60                                   |                          | ms            |
| <b>BATTERY CHARGER</b>   |  |   |                          |                                      |                          |               |
| $I_{BAT}$  | Source current for BAT pin short-circuit detection   | $V_{BAT} = 1.5\text{ V}$  | 4                        | 7.5                                  | 11                       | mA            |
| $V_{BAT(SC)}$  | BAT pin short-circuit detection threshold  | $V_{BAT}$ rising  | 1.6                      | 1.8                                  | 2                        | V             |
| $V_{BAT(REG)}$   | Battery charge voltage   | (76)  | 4.358                    | 4.4                                  | 4.44                     | V             |
|  |  | (78)  | 4.31                     | 4.35                                 | 4.39                     |               |
| $V_{LOWV}$   | Pre-charge to fast-charge transition threshold   | $V_{IN} > V_{UVLO}$ and $V_{IN} > V_{BAT} + V_{IN(DT)}$   | 2.9                      | 3                                    | 3.1                      | V             |
| $t_{DGL1(LOWV)}$   | Deglitch time on pre-charge to fast-charge transition  |   |                          | 25                                   |                          | ms            |
| $t_{DGL2(LOWV)}$   | Deglitch time on fast-charge to pre-charge transition  |   |                          | 25                                   |                          | ms            |

## Electrical Characteristics (continued)

 Over junction temperature range ( $0^{\circ} \leq T_J \leq 125^{\circ}\text{C}$ ) and the recommended supply voltage range (unless otherwise noted)

| PARAMETER  |  | TEST CONDITIONS  | MIN  | TYP                                  | MAX                                 | UNIT |
|--|--|--|--|--------------------------------------|-------------------------------------|------|
| $I_{\text{CHG}}$   | Battery fast charge current range                              | $V_{\text{BAT(REG)}} > V_{\text{BAT}} > V_{\text{LOWV}}$ , $V_{\text{IN}} = 5\text{ V}$ $\overline{\text{CE}} = \text{LO}$ ,<br>$\text{EN1} = \text{LO}$ , $\text{EN2} = \text{HI}$  | 100  |                                      | 1500                                | mA   |
|  | Battery fast charge current                                    | $\overline{\text{CE}} = \text{LO}$ , $\text{EN1} = \text{LO}$ , $\text{EN2} = \text{HI}$ ,<br>$V_{\text{BAT}} > V_{\text{LOWV}}$ , $V_{\text{IN}} = 5\text{ V}$ , $I_{\text{INmax}} > I_{\text{CHG}}$ , no load on OUT pin,<br>thermal loop and DPPM loop not active |  | $K_{\text{ISET}}/R_{\text{ISET}}$    |                                     | A    |
| $K_{\text{ISET}}$  | Fast charge current factor                                     |  | 797  | 890                                  | 975                                 | AΩ   |
| $I_{\text{PRECHG}}$  | Pre-charge current   |  | $K_{\text{PRECHG}}/R_{\text{ISET}}$              |                                      |                                     | A    |
| $K_{\text{PRECHG}}$  | Pre-charge current factor                                      |  | 60   | 88                                   | 118                                 | AΩ   |
| $I_{\text{TERM}}$  | Termination comparator detection threshold<br>(internally set) | $\overline{\text{CE}} = \text{LO}$ , ( $\text{EN1}$ , $\text{EN2}$ ) $\neq$ ( $\text{LO}$ , $\text{LO}$ ),<br>$V_{\text{BAT}} > V_{\text{RCH}}$ , $t < t_{\text{MAXCH}}$ , $V_{\text{IN}} = 5\text{ V}$ , DPPM loop and thermal<br>loop not active                   | $0.09 \times I_{\text{CHG}}$                     | $0.1 \times I_{\text{CHG}}$          | $0.11 \times I_{\text{CHG}}$        | A    |
|  |  | $\overline{\text{CE}} = \text{LO}$ , ( $\text{EN1}$ , $\text{EN2}$ ) = ( $\text{LO}$ , $\text{LO}$ ),<br>$V_{\text{BAT}} > V_{\text{RCH}}$ , $t < t_{\text{MAXCH}}$ , $V_{\text{IN}} = 5\text{ V}$ , DPPM loop and thermal<br>loop not active                        | $0.027 \times I_{\text{CHG}}$                    | $0.033 \times I_{\text{CHG}}$        | $0.040 \times I_{\text{CHG}}$       |      |
| $I_{\text{BIAS(TERM)}}$  | Current for external termination-setting resistor              | $V_{\text{IN}} > V_{\text{UVLO}}$ and $V_{\text{IN}} > V_{\text{BAT}} + V_{\text{IN(DT)}}$   | 72   | 75                                   | 78                                  | μA   |
| $t_{\text{DGL(TERM)}}$   | Deglintch time, termination detected                           |  |  | 25                                   |                                     | ms   |
| $V_{\text{RCH}}$   | Recharge detection threshold                                   | $V_{\text{IN}} > V_{\text{UVLO}}$ and $V_{\text{IN}} > V_{\text{BAT}} + V_{\text{IN(DT)}}$   | $V_{\text{BAT(REG)}} - 140\text{mV}$             | $V_{\text{BAT(REG)}} - 100\text{mV}$ | $V_{\text{BAT(REG)}} - 60\text{mV}$ | V    |
| $t_{\text{DGL(RCH)}}$  | Deglintch time, recharge threshold detected                    |  |  | 62.5                                 |                                     | ms   |
| $t_{\text{DGL(NO-IN)}}$  | Delay time, input power loss to OUT LDO turn-off               | $V_{\text{BAT}} = 3.6\text{ V}$ . Time measured from<br>$V_{\text{IN}}: 5\text{ V} \rightarrow 3\text{ V}$ 1 μs fall-time  |  | 20                                   |                                     | ms   |
| $I_{\text{BAT(DET)}}$  | Sink current for battery detection                             | $V_{\text{BAT}} = 2.5\text{ V}$  | 5  | 7.5                                  | 10                                  | mA   |
| $t_{\text{DET}}$   | Battery detection timer  | BAT high or low  |  | 250                                  |                                     | ms   |
| <b>BATTERY CHARGING TIMERS</b>   |  |  |  |                                      |                                     |      |
| $t_{\text{PRECHG}}$  | Pre-charge safety timer value                                  | TMR = floating   | 1440   | 1800                                 | 2160                                | s    |
| $t_{\text{MAXCHG}}$  | Charge safety timer value                                      | TMR = floating   | 14400  | 18000                                | 21600                               | s    |
| $t_{\text{PRECHG}}$  | Pre-charge safety timer value                                  | $18\text{ k}\Omega < R_{\text{TMR}} < 72\text{ k}\Omega$   | $R_{\text{TMR}} \times K_{\text{TMR}}$           |                                      |                                     | s    |
| $t_{\text{MAXCHG}}$  | Charge safety timer value                                      | $18\text{ k}\Omega < R_{\text{TMR}} < 72\text{ k}\Omega$   | $10 \times R_{\text{TMR}} \times K_{\text{TMR}}$ |                                      |                                     | s    |
| $K_{\text{TMR}}$   | Timer factor   |  | 36   | 48                                   | 60                                  | s/kΩ |
| <b>BATTERY-PACK NTC MONITOR<sup>(1)</sup></b>                                  |  |  |  |                                      |                                     |      |
| $I_{\text{NTC}}$   | NTC bias current   | $V_{\text{IN}} > \text{UVLO}$ and $V_{\text{IN}} > V_{\text{BAT}} + V_{\text{IN(DT)}}$   | 72   | 75                                   | 80                                  | μA   |
| $V_{\text{HOT}}$   | High temperature trip point                                    | Battery charging, $V_{\text{TS}}$ Falling  | 270  | 300                                  | 330                                 | mV   |
| $V_{\text{HYS(HOT)}}$  | Hysteresis on high trip point                                  | Battery charging, $V_{\text{TS}}$ Rising from $V_{\text{HOT}}$   |  | 30                                   |                                     | mV   |
| $V_{\text{COLD}}$  | Low temperature trip point                                     | Battery charging, $V_{\text{TS}}$ Rising   | 2000   | 2100                                 | 2200                                | mV   |
| $V_{\text{HYS(COLD)}}$   | Hysteresis on low trip point                                   | Battery charging, $V_{\text{TS}}$ Falling from $V_{\text{COLD}}$   |  | 300                                  |                                     | mV   |
| $t_{\text{DGL(TS)}}$   | Deglintch time, pack temperature fault detection               | TS fault detected to charger disable   |  | 50                                   |                                     | ms   |
| $V_{\text{DIS(TS)}}$   | TS function disable threshold                                  | TS unconnected   |  | $V_{\text{IN}} - 200\text{mV}$       |                                     | V    |
| <b>THERMAL REGULATION</b>  |  |  |  |                                      |                                     |      |
| $T_{\text{J(REG)}}$  | Temperature regulation limit                                   |  |  | 125                                  |                                     | °C   |
| $T_{\text{J(OFF)}}$  | Thermal shutdown temperature                                   | $T_J$ Rising   |  | 155                                  |                                     | °C   |
| $T_{\text{J(OFF-HYS)}}$  | Thermal shutdown hysteresis                                    |  |  | 20                                   |                                     | °C   |
| <b>LOGIC LEVELS ON EN1, EN2, <math>\overline{\text{CE}}</math>, SYSOFF, TD</b> |  |  |  |                                      |                                     |      |
| $V_{\text{IL}}$  | Logic LOW input voltage  |  | 0  |                                      | 0.4                                 | V    |
| $V_{\text{IH}}$  | Logic HIGH input voltage                                       |  | 1.4  |                                      | 6                                   | V    |
| $I_{\text{IL}}$  | Input sink current   | $V_{\text{IL}} = 0\text{ V}$   |  |                                      | 1                                   | μA   |
| $I_{\text{IH}}$  | Input source current   | $V_{\text{IH}} = 1.4\text{ V}$   |  |                                      | 10                                  | μA   |
| <b>LOGIC LEVELS ON PGOOD, CHG</b>  |  |  |  |                                      |                                     |      |
| $V_{\text{OL}}$  | Output LOW voltage   | $I_{\text{SINK}} = 5\text{ mA}$  |  |                                      | 0.4                                 | V    |

(1) These numbers set trip points of  $0^{\circ}\text{C}$  and  $50^{\circ}\text{C}$  while charging, with  $3^{\circ}\text{C}$  hysteresis on the trip points, with a Vishay Type 2 curve NTC with an R25 of  $10\text{ k}\Omega$ .



### 8.7 Typical Characteristics

$V_{IN} = 6\text{ V}$ ,  $EN1=1$ ,  $EN2=0$ , bq24078 application circuit,  $T_A = 25^\circ\text{C}$ , unless otherwise noted.

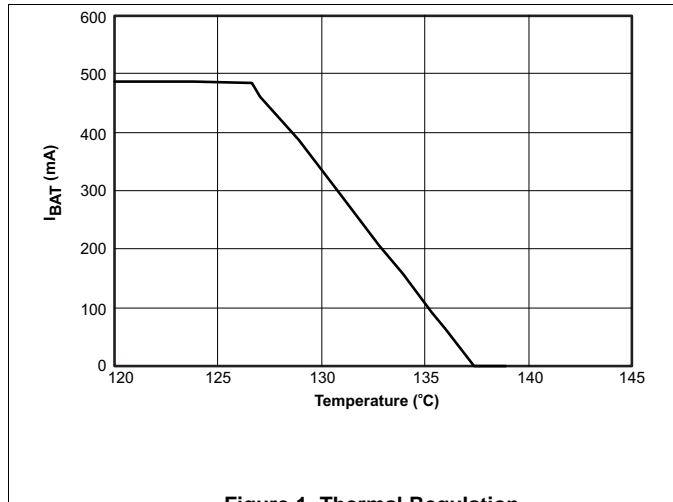

Figure 1. Thermal Regulation

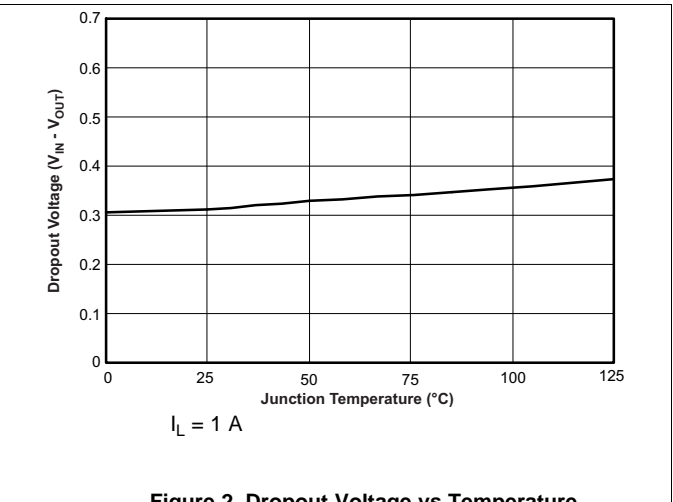

Figure 2. Dropout Voltage vs Temperature

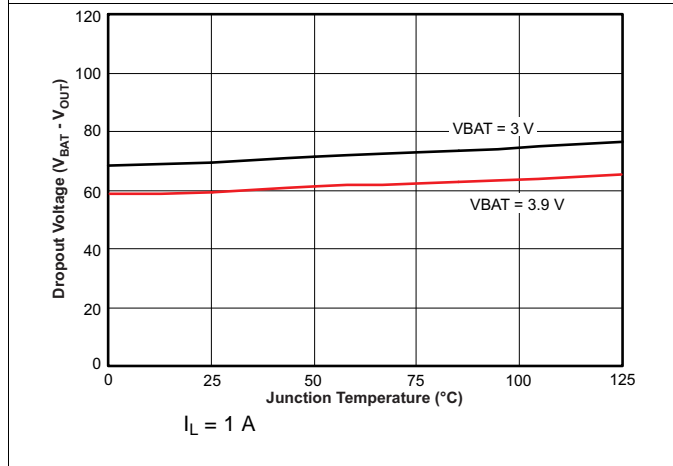

Figure 3. Dropout Voltage vs Temperature No Input Supply

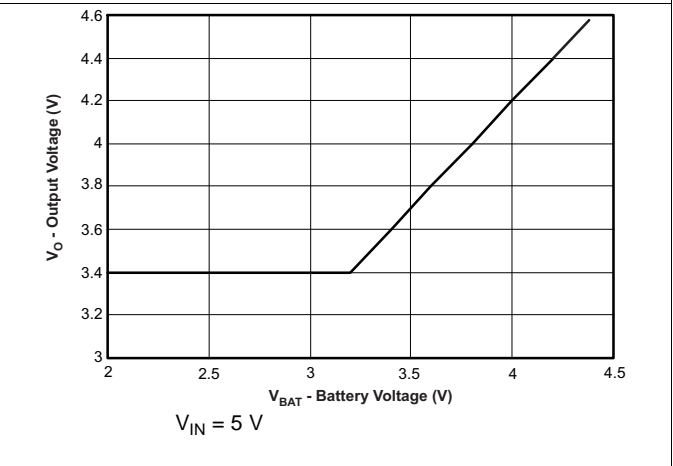

Figure 4. bq24078 Output Regulation Voltage vs Battery Voltage

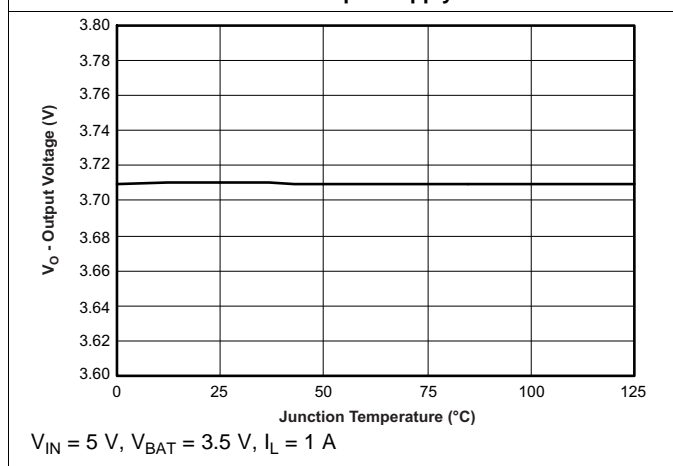

Figure 5. bq24076 Output Regulation Voltage vs Temperature

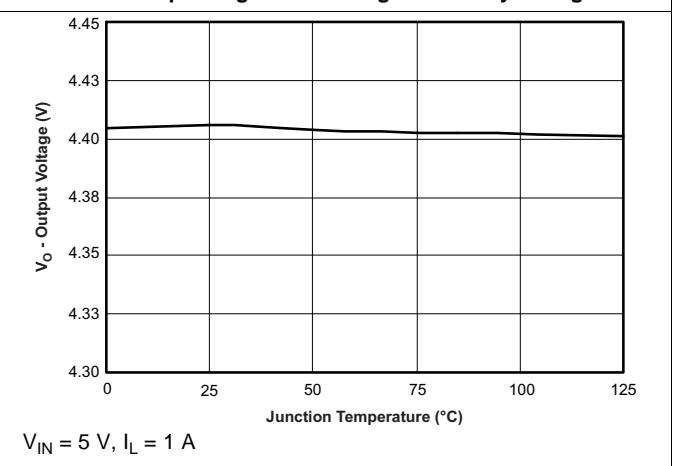
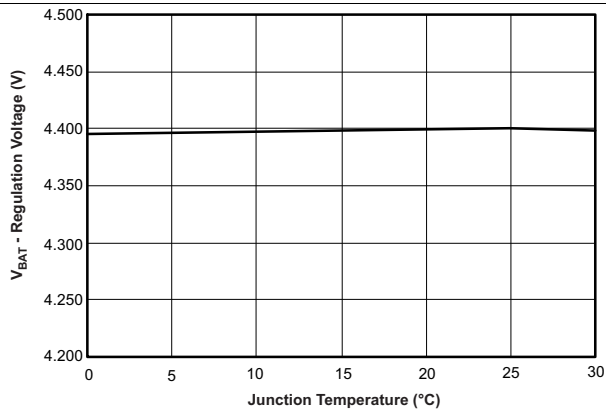

Figure 6. bq24076 Output Regulation Voltage vs Temperature

### Typical Characteristics (continued)

$V_{IN} = 6\text{ V}$ ,  $EN1=1$ ,  $EN2=0$ , bq24078 application circuit,  $T_A = 25^\circ\text{C}$ , unless otherwise noted.



**Figure 7. bq24076**  
BAT Regulation Voltage vs Temperature

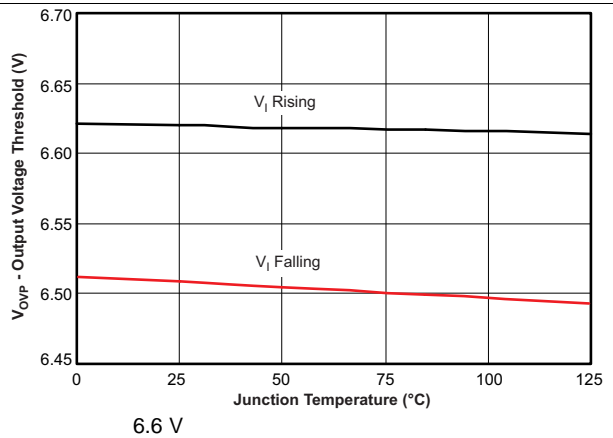

**Figure 8. bq24076/78**  
Overvoltage Protection Threshold vs Temperature

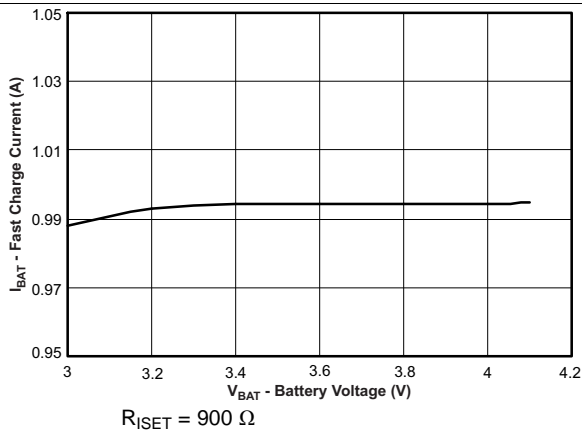

**Figure 9. Fastcharge Current vs Battery Voltage**

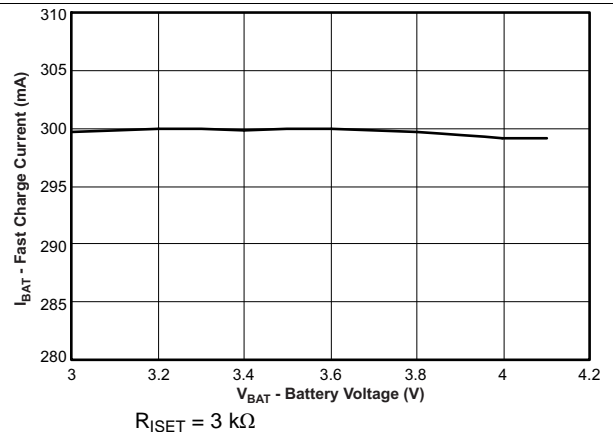

**Figure 10. Fastcharge Current vs Battery Voltage**

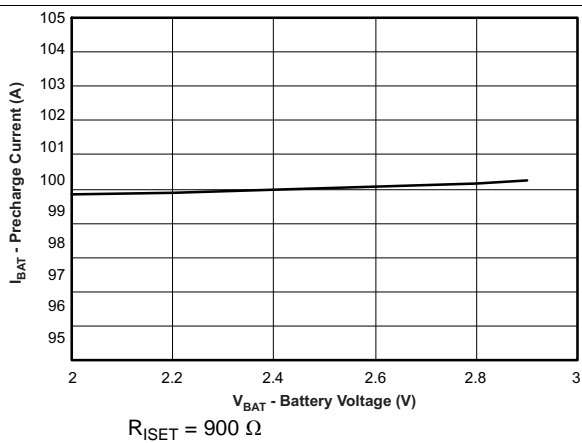

**Figure 11. Precharge Current vs Battery Voltage**

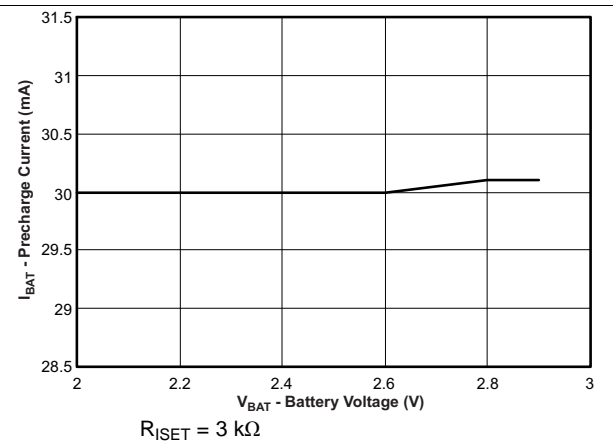

**Figure 12. Precharge Current vs Battery Voltage**

## 9 Detailed Description

### 9.1 Overview

The bq2407x devices are integrated Li-Ion linear chargers and system power path management devices targeted at space-limited portable applications. The device powers the system while simultaneously and independently charging the battery. This feature reduces the number of charge and discharge cycles on the battery, allows for proper charge termination and enables the system to run with a defective or absent battery pack. This feature also allows instant system turn-on even with a totally discharged battery. The input power source for charging the battery and running the system can be an AC adapter or a USB port. The devices feature Dynamic Power Path Management (DPPM), which shares the source current between the system and battery charging, and automatically reduces the charging current if the system load increases. When charging from a USB port, the input dynamic power management ( $V_{IN}$ -DPM) circuit reduces the input current if the input voltage falls below a threshold, thus preventing the USB port from crashing. The power-path architecture also permits the battery to supplement the system current requirements when the adapter cannot deliver the peak system currents.

## 9.2 Functional Block Diagram

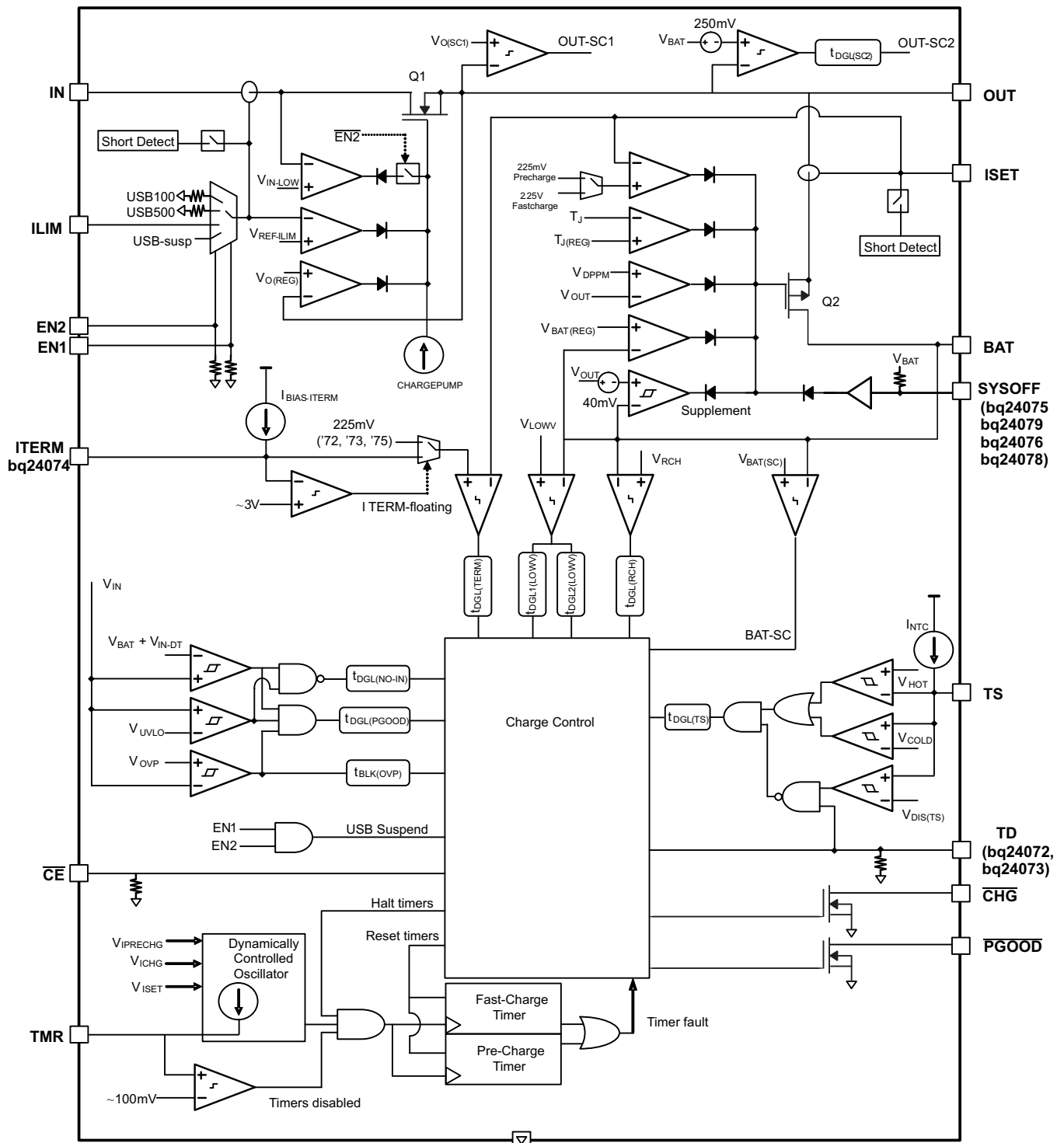

Copyright © 2017, Texas Instruments Incorporated

## 9.3 Feature Description

### 9.3.1 Undervoltage Lockout (UVLO)

The bq2407x family remains in power down mode when the input voltage at the IN pin is below the undervoltage threshold (UVLO).

During the power down mode the host commands at the control inputs ( $\overline{\text{CE}}$ , EN1 and EN2) are ignored. The Q1 FET connected between IN and OUT pins is off, and the status outputs  $\overline{\text{CHG}}$  and  $\overline{\text{PGOOD}}$  are high impedance. The Q2 FET that connects BAT to OUT is ON. (If SYSOFF is high, Q2 is off). During power down mode, the  $V_{\text{OUT(SC2)}}$  circuitry is active and monitors for overload conditions on OUT.

### 9.3.2 Power On

When  $V_{\text{IN}}$  exceeds the UVLO threshold, the bq2407x powers up. While  $V_{\text{IN}}$  is below  $V_{\text{BAT}} + V_{\text{IN(DT)}}$ , the host commands at the control inputs ( $\overline{\text{CE}}$ , EN1 and EN2) are ignored. The Q1 FET connected between IN and OUT pins is off, and the status outputs  $\overline{\text{CHG}}$  and  $\overline{\text{PGOOD}}$  are high impedance. The Q2 FET that connects BAT to OUT is ON. (If SYSOFF is high, Q2 is off). During this mode, the  $V_{\text{OUT(SC2)}}$  circuitry is active and monitors for overload conditions on OUT.

Once  $V_{\text{IN}}$  rises above  $V_{\text{BAT}} + V_{\text{IN(DT)}}$ ,  $\overline{\text{PGOOD}}$  is driven low to indicate the valid power status and the  $\overline{\text{CE}}$ , EN1, and EN2 inputs are read. The device enters standby mode if (EN1 = EN2 = HI) or if an input overvoltage condition occurs. In standby mode, Q1 is OFF and Q2 is ON so OUT is connected to the battery input. (If SYSOFF is high, FET Q2 is off). During this mode, the  $V_{\text{OUT(SC2)}}$  circuitry is active and monitors for overload conditions on OUT.

When the input voltage at IN is within the valid range:  $V_{\text{IN}} > \text{UVLO}$  **AND**  $V_{\text{IN}} > V_{\text{BAT}} + V_{\text{IN(DT)}}$  **AND**  $V_{\text{IN}} < V_{\text{OVP}}$ , and the EN1 and EN2 pins indicate that the USB suspend mode is not enabled [(EN1, EN2) ≠ (HI, HI)] all internal timers and other circuit blocks are activated. The device then checks for short-circuits at the ISET and ILIM pins. If no short conditions exists, the device switches on the input FET Q1 with a 100mA current limit to checks for a short circuit at OUT. When  $V_{\text{OUT}}$  is above  $V_{\text{O(SC1)}}$ , the FET Q1 switches to the current limit threshold set by EN1, EN2 and  $R_{\text{ILIM}}$  and the device enters into the normal operation. During normal operation, the system is powered by the input source (Q1 is regulating), and the device continuously monitors the status of  $\overline{\text{CE}}$ , EN1 and EN2 as well as the input voltage conditions.

**Feature Description (continued)**

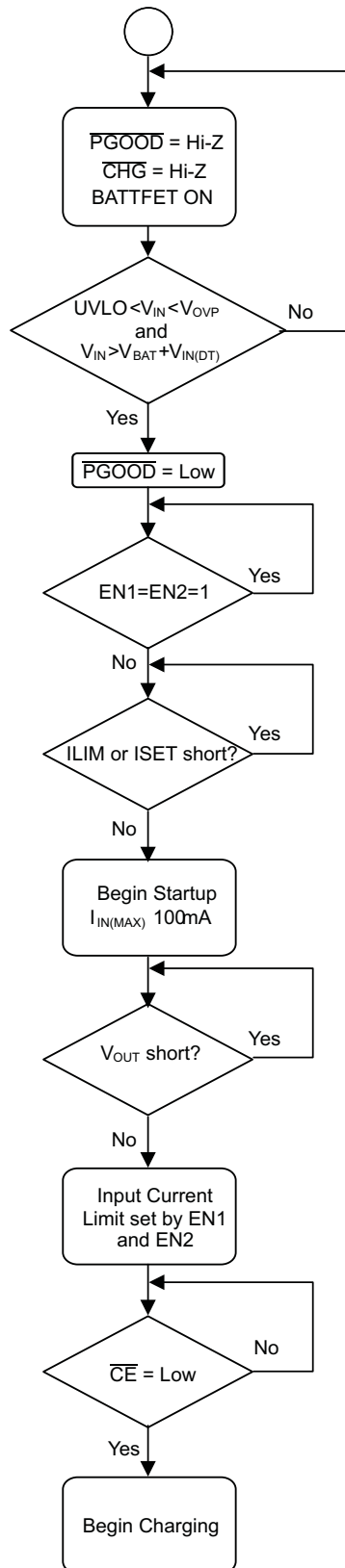

**Figure 13. Startup Flow Diagram**

## Feature Description (continued)

### 9.3.3 Overvoltage Protection (OVP)

The bq2407x accepts inputs up to 28 V without damage. Additionally, an overvoltage protection (OVP) circuit is implemented that shuts off the internal LDO and discontinues charging when  $V_{IN} > V_{OVP}$  for a period long than  $t_{DGL(OVP)}$ . When in OVP, the system output (OUT) is connected to the battery and PGOOD is high impedance. Once the OVP condition is removed, a new power on sequence starts (see [Power On](#)). The safety timers are reset and a new charge cycle will be indicated by the CHG output.

### 9.3.4 Dynamic Power-Path Management

The bq2407x features an OUT output that powers the external load connected to the battery. This output is active whenever a source is connected to IN or BAT. The following sections discuss the behavior of OUT with a source connected to IN to charge the battery and a battery source only.

#### 9.3.4.1 Input Source Connected (ADAPTER or USB)

With a source connected, the dynamic power-path management (DPPM) circuitry of the bq2407x monitors the input current continuously. For the bq24076/78, OUT is regulated to 210 mV above the voltage at BAT. When the BAT voltage falls below 3.2 V, OUT is clamped to 3.41 V. This allows for proper startup of the system load even with a discharged battery. The current into IN is shared between charging the battery and powering the system load at OUT. The bq2407x has internal selectable current limits of 100 mA (USB100) and 500 mA (USB500) for charging from USB ports, as well as a resistor-programmable input current limit.

The bq2407x is USB IF compliant for the inrush current testing. The USB specification allows up to 10  $\mu$ F to be hard started, which establishes 50  $\mu$ C as the maximum inrush charge value when exceeding 100 mA. The input current limit for the bq2407x prevents the input current from exceeding this limit, even with system capacitances greater than 10  $\mu$ F. The input capacitance to the device must be selected small enough to prevent a violation (<10  $\mu$ F), as this current is not limited. [Figure 14](#) demonstrates the start-up of the bq2407x and compares it to the USB-IF specification.

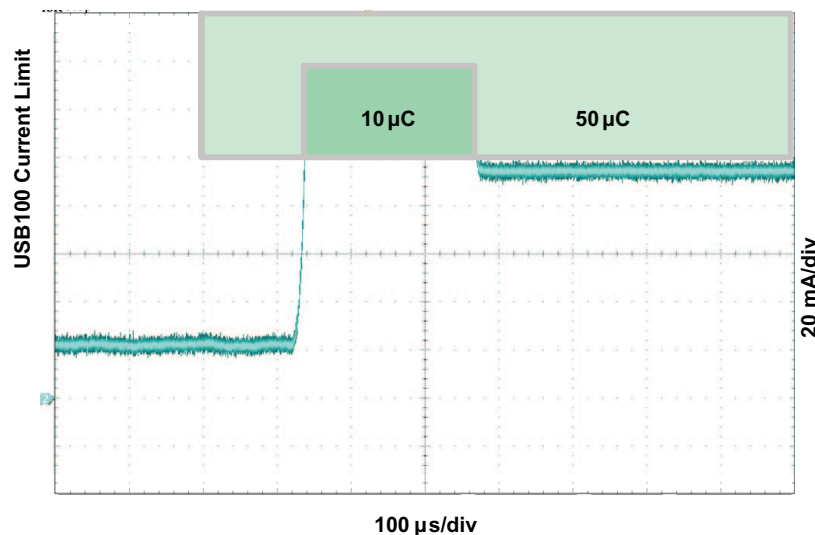

Figure 14. USB-IF Inrush Current Test

The input current limit selection is controlled by the state of the EN1 and EN2 pins as shown in the [EN1/EN2 Settings](#) table in [Pin Configuration and Functions](#). When using the resistor-programmable current limit, the input current limit is set by the value of the resistor connected from the ILIM pin to VSS, and is given by the equation:

$$I_{IN-MAX} = K_{ILIM}/R_{ILIM} \quad (1)$$

The input current limit is adjustable up to 1.5 A. The valid resistor range is 1.1 k $\Omega$  to 8 k $\Omega$ .

## Feature Description (continued)

When the IN source is connected, priority is given to the system load. The DPPM and Battery Supplement modes are used to maintain the system load. Figure 16 illustrates examples of the DPPM and supplement modes. These modes are explained in detail in the following sections.

### 9.3.4.1.1 Input DPM Mode ( $V_{IN-DPM}$ )

The bq2407x utilizes the  $V_{IN-DPM}$  mode for operation from current-limited USB ports. When EN1 and EN2 are configured for USB100 (EN2=0, EN1=0) or USB500 (EN2=0, EN1=1) modes, the input voltage is monitored. If  $V_{IN}$  falls to  $V_{IN-DPM}$ , the input current limit is reduced to prevent the input voltage from falling further. This prevents the bq2407x from crashing poorly designed or incorrectly configured USB sources. Figure 15 shows the  $V_{IN-DPM}$  behavior to a current limited source. In this figure, the input source has a 400-mA current limit and the device is in USB500 mode (EN1=1, EN2=0).

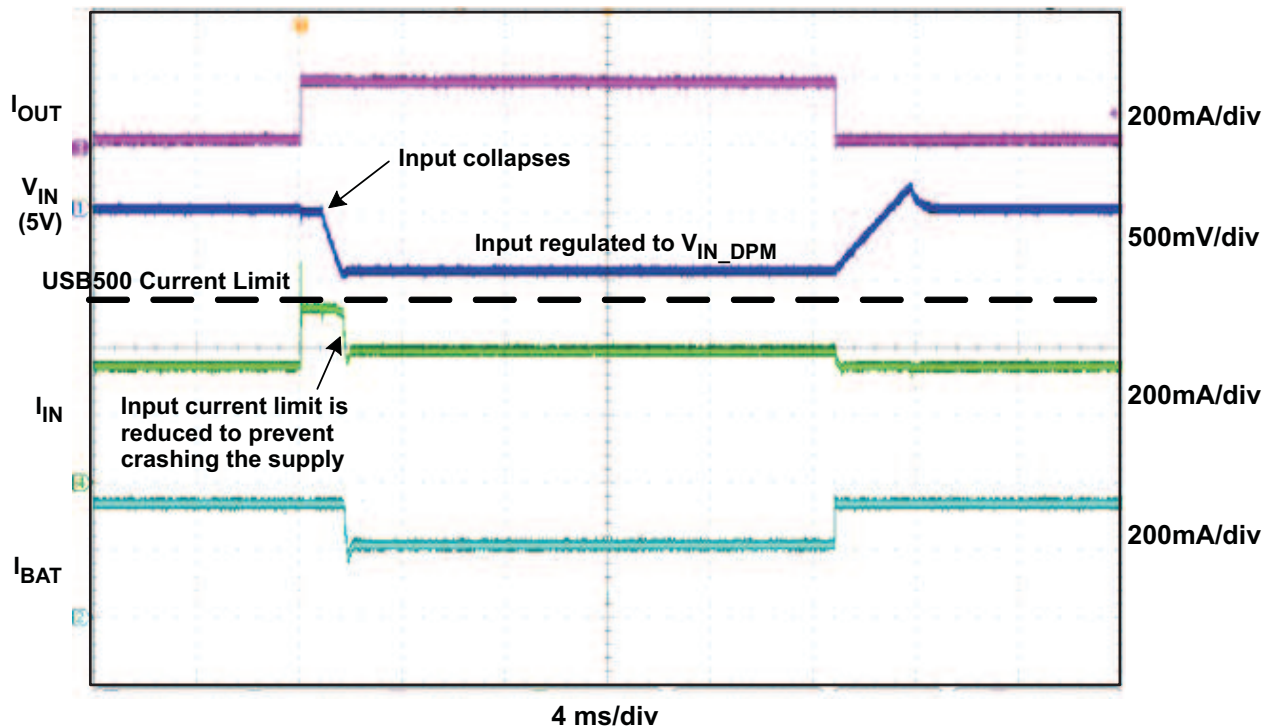

Figure 15.  $V_{IN-DPM}$  Waveform

### 9.3.4.1.2 DPPM Mode

When the sum of the charging and system load currents exceeds the maximum input current (programmed with EN1, EN2, and ILIM pins), the voltage at OUT decreases. Once the voltage on the OUT pin falls to  $V_{DPPM}$ , the bq2407x enters DPPM mode. In this mode, the charging current is reduced as the OUT current increases in order to maintain the system output. Battery termination is disabled while in DPPM mode.

### 9.3.4.1.3 Battery Supplement Mode

While in DPPM mode, if the charging current falls to zero and the system load current increases beyond the programmed input current limit, the voltage at OUT reduces further. When the OUT voltage drops below the  $V_{BSUP1}$  threshold, the battery supplements the system load. The battery stops supplementing the system load when the voltage at OUT rises above the  $V_{BSUP2}$  threshold.

During supplement mode, the battery supplement current is not regulated (BAT-FET is fully on), however there is a short circuit protection circuit built in. Figure 31 demonstrates supplement mode. If during battery supplement mode, the voltage at OUT drops  $V_{O(SC2)}$  below the BAT voltage, the OUT output is turned off if the overload exists after  $t_{DGL(SC2)}$ . The short circuit recovery timer then starts counting. After  $t_{REC(SC2)}$ , OUT turns on and attempts to restart. If the short circuit remains, OUT is turned off and the counter restarts. Battery termination is disabled while in supplement mode.



Feature Description (continued)

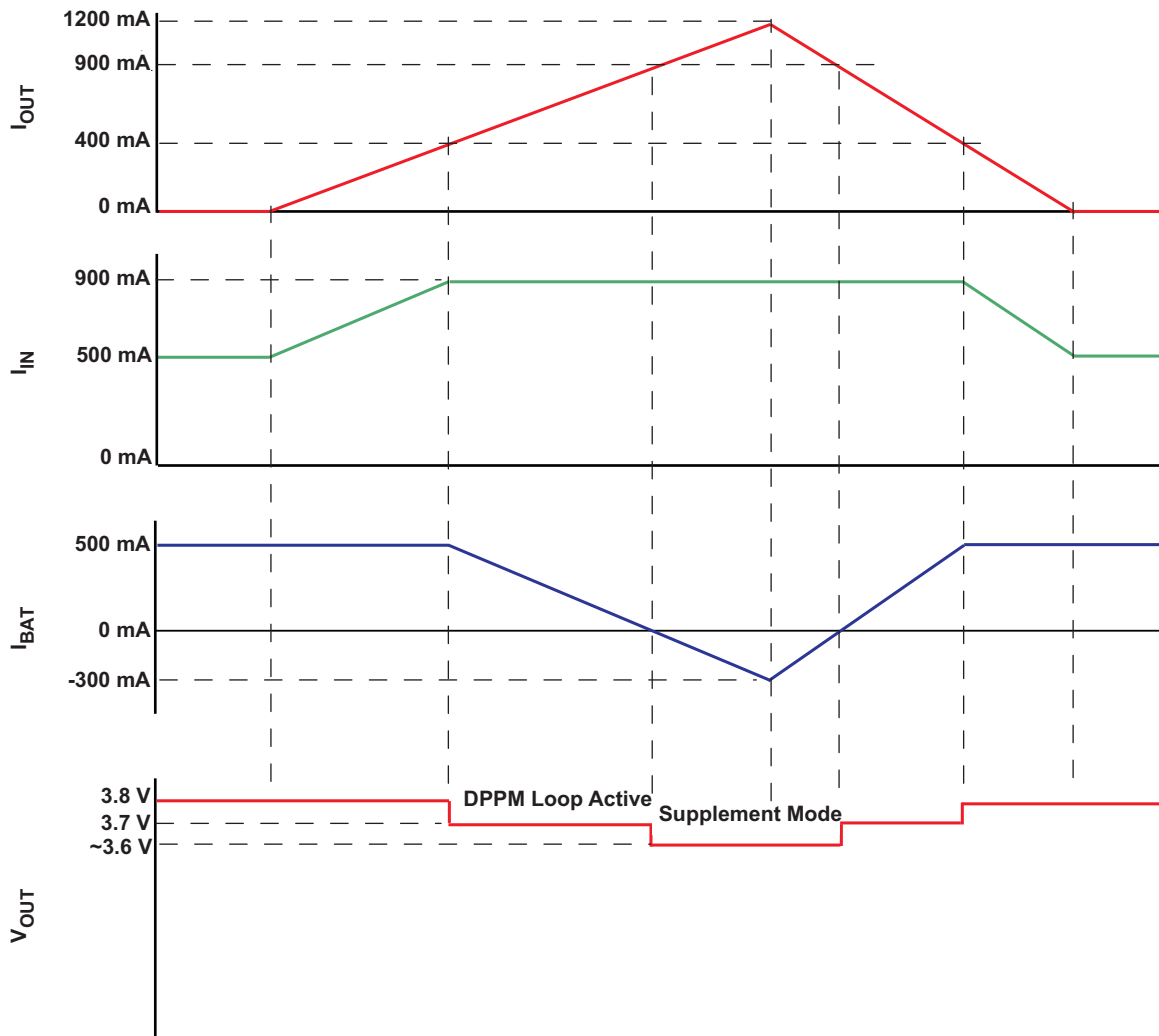

Figure 16. bq24076/78 DPPM and Battery Supplement Modes ( $V_{OREG} = V_{BAT} + 210 \text{ mV}$ ,  $V_{BAT} = 3.6 \text{ V}$ )

9.3.4.2 Input Source Not Connected

When no source is connected to the IN input, OUT is powered strictly from the battery. During this mode the current into OUT is not regulated, similar to *Battery Supplement Mode*, however the short circuit circuitry is active. If the OUT voltage falls below the BAT voltage by 250 mV for longer than  $t_{DGL(SC2)}$ , OUT is turned off. The short circuit recovery timer then starts counting. After  $t_{REC(SC2)}$ , OUT turns on and attempts to restart. If the short circuit remains, OUT is turned off and the counter restarts. This ON/OFF cycle continues until the overload condition is removed.

9.3.5 Battery Charging

Set  $\overline{CE}$  low to initiate battery charging. First, the device checks for a short-circuit on the BAT pin by sourcing  $I_{BAT(SC)}$  to the battery and monitoring the voltage. When the BAT voltage exceeds  $V_{BAT(SC)}$ , the battery charging continues. The battery is charged in three phases: conditioning pre-charge, constant current fast charge (current regulation) and a constant voltage tapering (voltage regulation). In all charge phases, an internal control loop monitors the IC junction temperature and reduces the charge current if an internal temperature threshold is exceeded.

Figure 17 illustrates a normal Li-Ion charge cycle using the bq2407x:

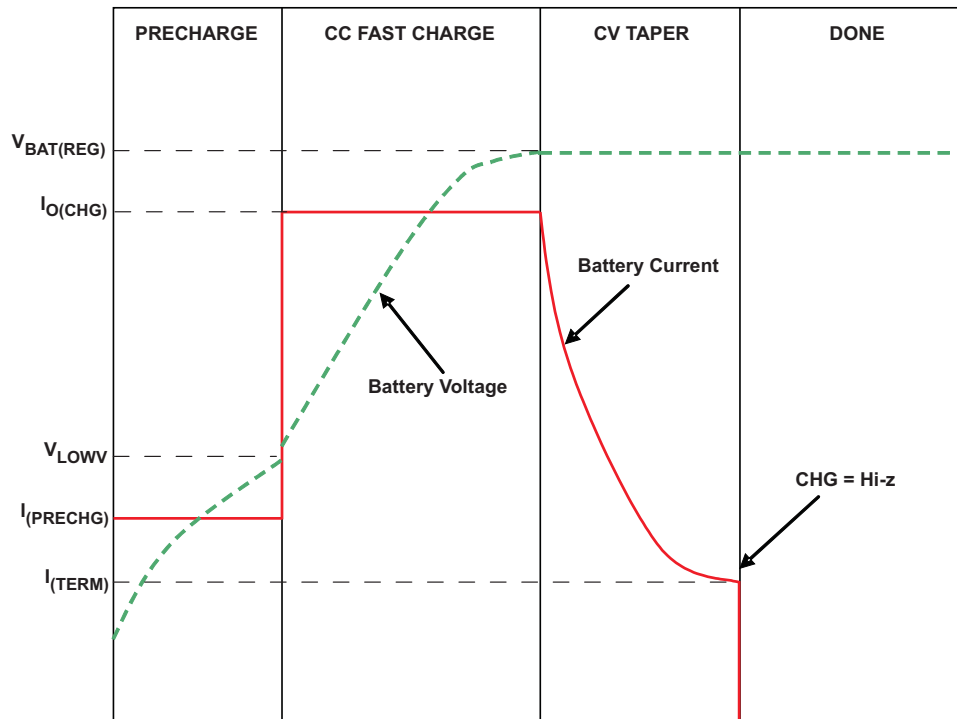
**Feature Description (continued)**

**Figure 17. Typical Charge Cycle**

In the pre-charge phase, the battery is charged at with the pre-charge current ( $I_{PRECHG}$ ). Once the battery voltage crosses the  $V_{LOWV}$  threshold, the battery is charged with the fast-charge current ( $I_{CHG}$ ). As the battery voltage reaches  $V_{BAT(REG)}$ , the battery is held at a constant voltage of  $V_{BAT(REG)}$  and the charge current tapers off as the battery approaches full charge. When the battery current reaches  $I_{TERM}$ , the  $\overline{CHG}$  pin indicates *charging done* by going high-impedance.

Note that termination detection is disabled whenever the charge rate is reduced because of the actions of the thermal loop, the DPPM loop or the  $V_{IN(LOW)}$  loop.

The value of the fast-charge current is set by the resistor connected from the ISET pin to VSS, and is given by the equation:

$$I_{CHG} = K_{ISET}/R_{ISET} \quad (2)$$

The charge current limit is adjustable up to 1.5 A. The valid resistor range is 590  $\Omega$  to 5.9 k $\Omega$ . If  $I_{CHG}$  is programmed as greater than the input current limit, the battery will not charge at the rate of  $I_{CHG}$ , but at the slower rate of  $I_{IN(MAX)}$  (minus the load current on the OUT pin, if any). In this case, the charger timers will be proportionately slowed down.

**9.3.5.1 Charge Current Translator**

When the charger is enabled, internal circuits generate a current proportional to the charge current at the ISET input. The current out of ISET is 1/400 ( $\pm 10\%$ ) of the charge current. This current, when applied to the external charge current programming resistor,  $R_{ISET}$ , generates an analog voltage that can be monitored by an external host to calculate the current sourced from BAT.

$$V_{ISET} = I_{CHARGE} / 400 \times R_{ISET} \quad (3)$$

Feature Description (continued)

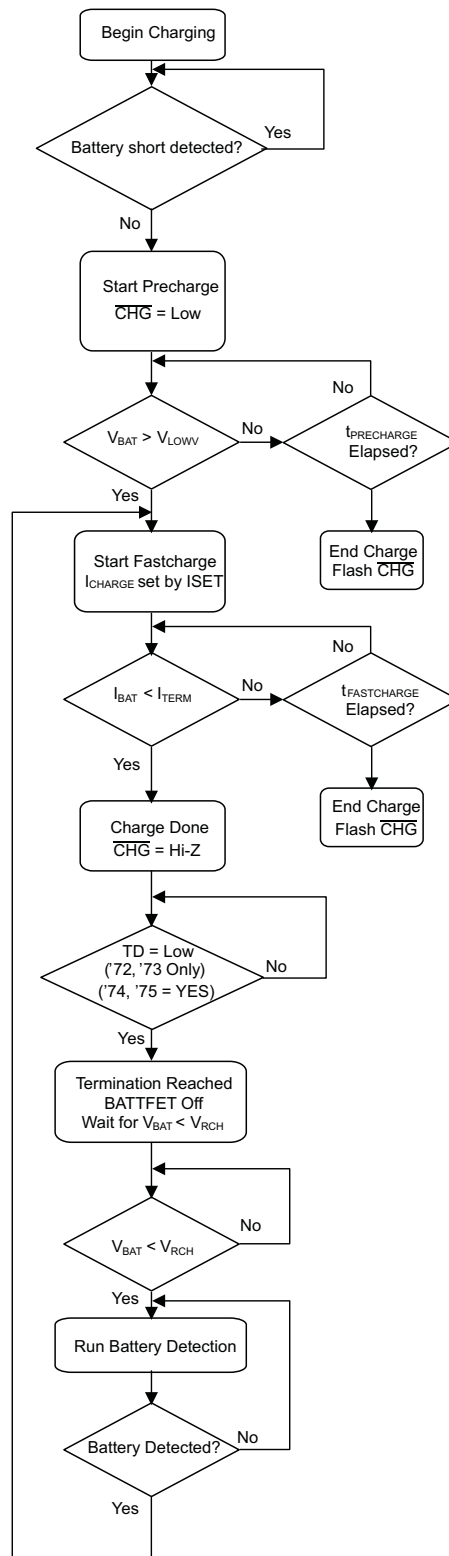

Figure 18. Battery Charging Flow Diagram

## Feature Description (continued)

### 9.3.5.2 Battery Detection and Recharge

The bq2407x automatically detects if a battery is connected or removed. Once a charge cycle is complete, the battery voltage is monitored. When the battery voltage falls below  $V_{RCH}$ , the battery detection routine is run. During battery detection, current ( $I_{BAT(DET)}$ ) is pulled from the battery for a duration  $t_{DET}$  to see if the voltage on BAT falls below  $V_{LOWV}$ . If not, charging begins. If it does, then it indicates that the battery is missing or the protector is open. Next, the precharge current is applied for  $t_{DET}$  to close the protector if possible. If  $V_{BAT} < V_{RCH}$ , then the protector closed and charging is initiated. If  $V_{BAT} > V_{RCH}$ , then the battery is determined to be missing and the detection routine continues.

### 9.3.5.3 Battery Disconnect (SYSOFF Input, bq24076, bq24078)

The bq24076 and bq24078 feature a SYSOFF input that allows the user to turn the FET Q2 off and disconnect the battery from the OUT pin. This is useful for disconnecting the system load from the battery, factory programming where the battery is not installed or for host side impedance track fuel gauging, such as bq27500, where the battery open circuit voltage level must be detected before the battery charges or discharges. The /CHG output remains low when SYSOFF is high. Connect SYSOFF to VSS, to turn Q2 on for normal operation. SYSOFF is internally pulled to VBAT through ~5 MΩ resistor.

### 9.3.5.4 Dynamic Charge Timers (TMR Input)

The bq2407x devices contain internal safety timers for the pre-charge and fast-charge phases to prevent potential damage to the battery and the system. The timers begin at the start of the respective charge cycles. The timer values are programmed by connecting a resistor from TMR to VSS. The resistor value is calculated using the following equation:

$$t_{PRECHG} = K_{TMR} \times R_{TMR} \quad (4)$$

$$t_{MAXCHG} = 10 \times K_{TMR} \times R_{TMR} \quad (5)$$

Leave TMR unconnected to select the internal default timers. Disable the timers by connecting TMR to VSS.

Reset the timers by toggling the CE pin, or by toggling EN1, EN2 pin to put the device in and out of USB suspend mode (EN1 = HI, EN2 = HI).

Note that timers are suspended when the device is in thermal shutdown, and the timers are slowed proportionally to the charge current when the device enters thermal regulation.

During the fast charge phase, several events increase the timer durations.

- The system load current activates the DPPM loop which reduces the available charging current
- The input current is reduced because the input voltage has fallen to  $V_{IN(LOW)}$
- The device has entered thermal regulation because the IC junction temperature has exceeded  $T_{J(REG)}$

During each of these events, the internal timers are slowed down proportionately to the reduction in charging current. For example, if the charging current is reduced by half for two minutes, the timer clock is reduced to half the frequency and the counter counts half as fast resulting in only one minute of "counting" time.

If the pre charge timer expires before the battery voltage reaches  $V_{LOWV}$ , the bq2407x indicates a fault condition. Additionally, if the battery current does not fall to  $I_{TERM}$  before the fast charge timer expires, a fault is indicated. The  $\overline{CHG}$  output flashes at approximately 2 Hz to indicate a fault condition. The fault condition is cleared by toggling  $\overline{CE}$  or the input power, entering/ exiting USB suspend mode, or an OVP event.

### 9.3.5.5 Status Indicators ( $\overline{PGOOD}$ , $\overline{CHG}$ )

The bq2407x contains two open-drain outputs that signal its status. The  $\overline{PGOOD}$  output signals when a valid input source is connected.  $\overline{PGOOD}$  is low when  $(V_{BAT} + V_{IN(DT)}) < V_{IN} < V_{OVP}$ . When the input voltage is outside of this range,  $\overline{PGOOD}$  is high impedance.

The charge cycle after power-up, CE going low, or exiting OVP is indicated with the  $\overline{CHG}$  pin on (low - LED on), whereas all refresh (subsequent) charges will result in the  $\overline{CHG}$  pin off (open - LED off). In addition, the  $\overline{CHG}$  signals timer faults by flashing at approximately 2 Hz.

**Table 2.  $\overline{\text{PGOOD}}$  Status Indicator**

| INPUT STATE  | $\overline{\text{PGOOD}}$ OUTPUT |
|--|----------------------------------|
| $V_{\text{IN}} < V_{\text{UVLO}}$                                      | High-impedance                   |
| $V_{\text{UVLO}} < V_{\text{IN}} < V_{\text{BAT}} + V_{\text{IN(DT)}}$ | High-impedance                   |
| $V_{\text{BAT}} + V_{\text{IN(DT)}} < V_{\text{IN}} < V_{\text{OVP}}$  | Low                              |
| $V_{\text{IN}} > V_{\text{OVP}}$                                       | High-impedance                   |

**Table 3.  $\overline{\text{CHG}}$  Status Indicator**

| CHARGE STATE                        | $\overline{\text{CHG}}$ OUTPUT |
|-------------------------------------|--------------------------------|
| Charging                            | Low (for first charge cycle)   |
| Charging suspended by thermal loop  |                                |
| Safety timers expired               | Flashing at 2 Hz               |
| Charging done                       | High-impedance                 |
| Recharging after termination        |                                |
| IC disabled or no valid input power |                                |
| Battery absent                      |                                |

### 9.3.5.6 Thermal Regulation and Thermal Shutdown

The bq2407x contain a thermal regulation loop that monitors the die temperature. If the temperature exceeds  $T_{\text{J(REG)}}$ , the device automatically reduces the charging current to prevent the die temperature from increasing further. In some cases, the die temperature continues to rise despite the operation of the thermal loop, particularly under high  $V_{\text{IN}}$  and heavy OUT system load conditions. Under these conditions, if the die temperature increases to  $T_{\text{J(OFF)}}$ , the input FET Q1 is turned OFF. FET Q2 is turned ON to ensure that the battery still powers the load on OUT. Once the device die temperature cools by  $T_{\text{J(OFF-HYS)}}$ , the input FET Q1 is turned on and the device returns to thermal regulation. Continuous overtemperature conditions result in a "hiccup" mode. During thermal regulation, the safety timers are slowed down proportionately to the reduction in current limit.

Note that this feature monitors the die temperature of the bq2407x. This is not synonymous with ambient temperature. Self heating exists due to the power dissipated in the IC because of the linear nature of the battery charging algorithm and the LDO associated with OUT. A modified charge cycle with the thermal loop active is shown in [Figure 19](#). Battery termination is disabled during thermal regulation.

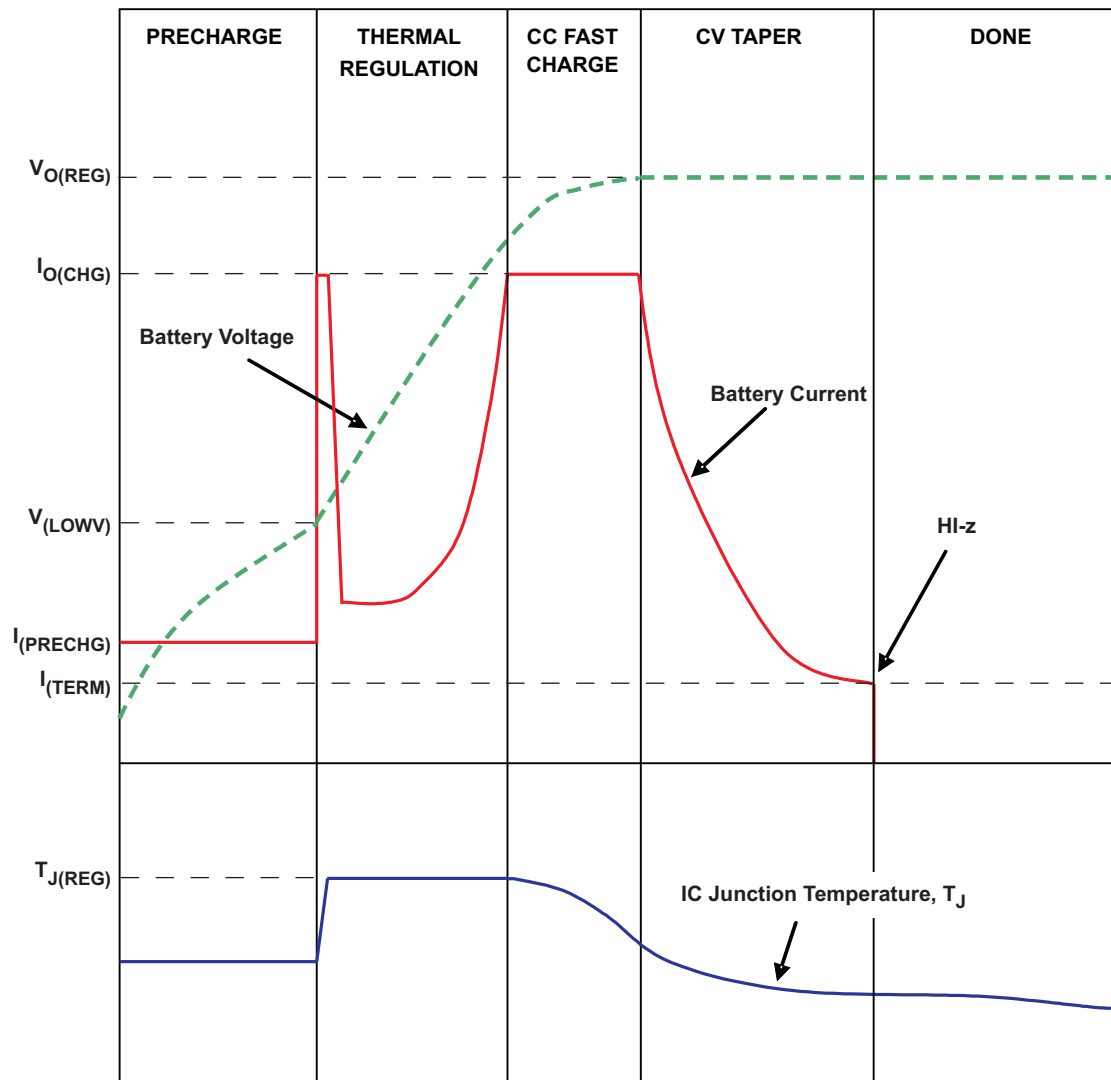

**Figure 19. Charge Cycle Modified by Thermal Loop**

### 9.3.6 Battery Pack Temperature Monitoring

The bq2407x features an external battery pack temperature monitoring input. The TS input connects to the NTC thermistor in the battery pack to monitor battery temperature and prevent dangerous over-temperature conditions. During charging,  $I_{NTC}$  is sourced to TS and the voltage at TS is continuously monitored. If, at any time, the voltage at TS is outside of the operating range ( $V_{COLD}$  to  $V_{HOT}$ ), charging is suspended. The timers maintain their values but suspend counting. When the voltage measured at TS returns to within the operation window, charging is resumed and the timers continue counting. When charging is suspended due to a battery pack temperature fault, the CHG pin remains low and continues to indicate charging.

For applications that do not require the TS monitoring function, connect a 10-k $\Omega$  resistor from TS to VSS to set the TS voltage at a valid level and maintain charging.

The allowed temperature range for 103AT-2 type thermistor is 0°C to 50°C. However, the user may increase the range by adding two external resistors. See [Figure 20](#) for the circuit details. The values for  $R_s$  and  $R_p$  are calculated using the following equations:

$$R_s = \frac{-(R_{TH} + R_{TC}) \pm \sqrt{\left( (R_{TH} + R_{TC})^2 - 4 \left\{ R_{TH} \times R_{TC} + \frac{V_H \times V_C}{(V_H - V_C) \times I_{TS}} \times (R_{TC} - R_{TH}) \right\} \right)}}{2} \quad (6)$$

$$R_p = \frac{V_H \times (R_{TH} + R_s)}{I_{TS} \times (R_{TH} + R_s) - V_H}$$

where

- $R_{TH}$ : Thermistor Hot Trip Value found in thermistor data sheet
  - $R_{TC}$ : Thermistor Cold Trip Value found in thermistor data sheet
  - $V_H$ : IC's Hot Trip Threshold = 0.3 V nominal
  - $V_C$ : IC's Cold Trip Threshold = 2.1 V nominal
  - $I_{TS}$ : IC's Output Current Bias = 75  $\mu$ A nominal
  - NTC Thermistor Semitec 103AT-4
- (7)

$R_s$  and  $R_p$  1% values were chosen closest to calculated values in [Table 4](#).

**Table 4. Calculated Values**

| COLD TEMP RESISTANCE AND TRIP THRESHOLD, $\Omega$ ( $^{\circ}$ C) | HOT TEMP RESISTANCE AND TRIP THRESHOLD, $\Omega$ ( $^{\circ}$ C) | EXTERNAL BIAS RESISTOR, $R_s$ ( $\Omega$ ) | EXTERNAL BIAS RESISTOR, $R_p$ ( $\Omega$ ) |
|---|--|--|--|
| 28000 (-0.6)  | 4000 (51)  | 0  | $\infty$                                   |
| 28480 (-1)  | 3536 (55)  | 487  | 845000                                     |
| 28480 (-1)  | 3021 (60)  | 1000                                       | 549000                                     |
| 33890 (-5)  | 4026 (51)  | 76.8                                       | 158000                                     |
| 33890 (-5)  | 3536 (55)  | 576  | 150000                                     |
| 33890 (-5)  | 3021 (60)  | 1100                                       | 140000                                     |

RHOT and RCOLD are the thermistor resistance at the desired hot and cold temperatures, respectively. The temperature window cannot be tightened more than using only the thermistor connected to TS, it can only be extended.

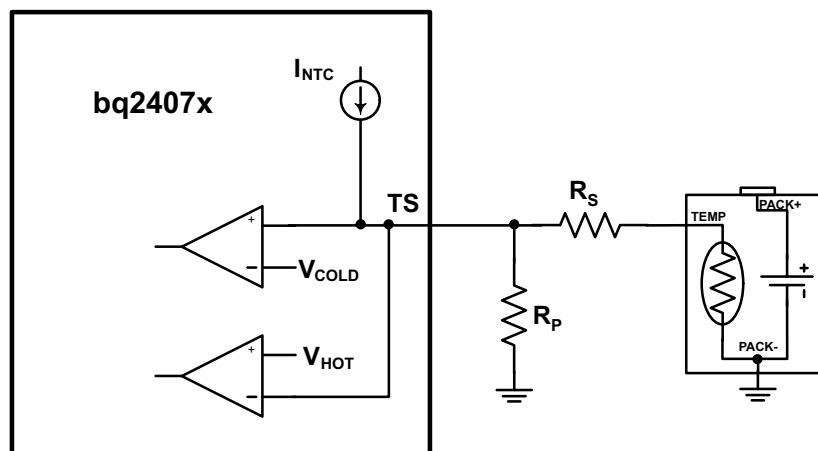

Copyright © 2017, Texas Instruments Incorporated

**Figure 20. Extended TS Pin Thresholds**

## 9.4 Device Functional Modes

### 9.4.1 Sleep Mode

When the input is between UVLO and  $V_{IN(DT)}$ , the device enters sleep mode. After entering sleep mode for >20 mS the internal FET connection between the IN and OUT pin is disabled and pulling the input to ground will not discharge the battery, other than the leakage on the BAT pin. If one has a full 1000-mAhr battery and the leakage is 10  $\mu$ A, then it would take 1000 mAhr / 10  $\mu$ A = 100000 hours (11.4 years) to discharge the battery. The self-discharge of the battery is typically five times higher than this.

### 9.4.2 Explanation of Deglitch Times and Comparator Hysteresis

**NOTE**

Figure 21 to Figure 25 are not to scale.

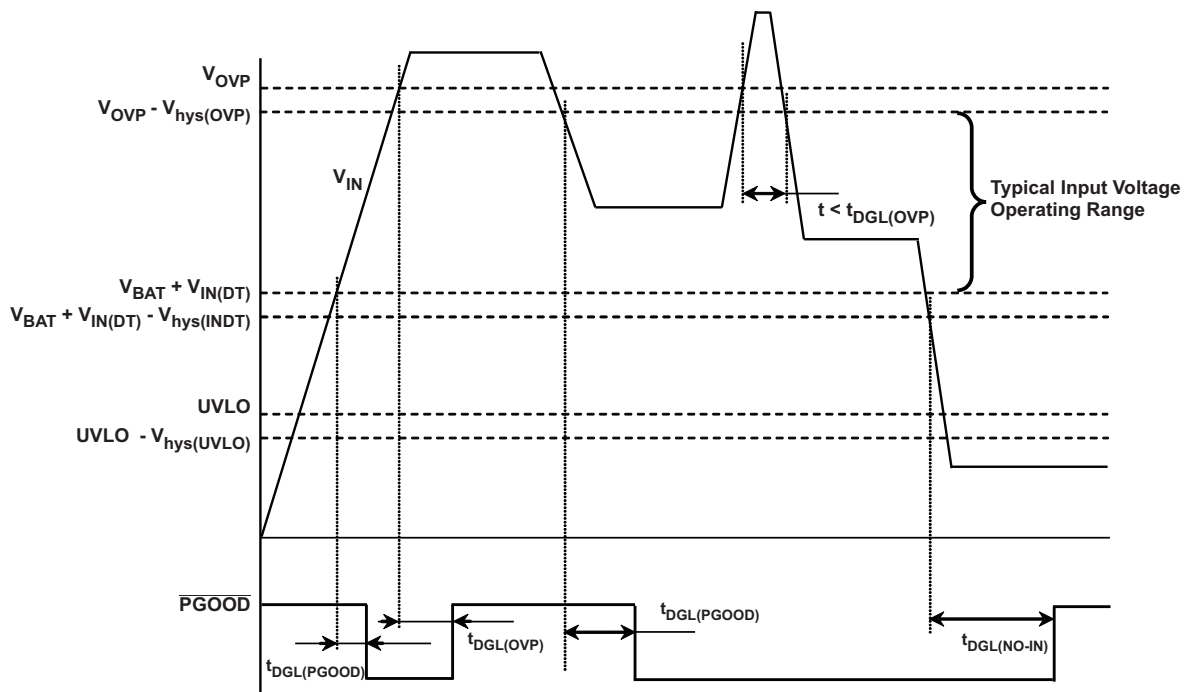

Figure 21. Power-Up, Power-Down, Power Good Indication

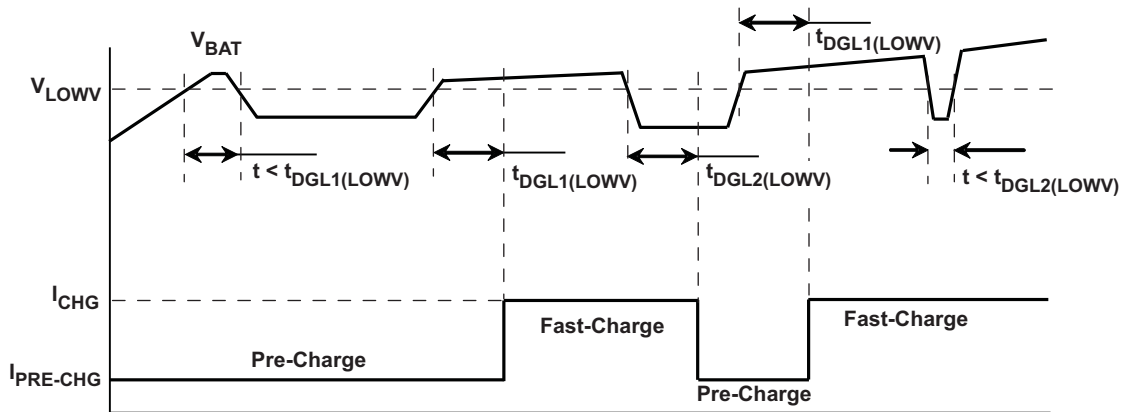

Figure 22. Precharge to Fast-Charge, Fast- to Pre-Charge Transition –  $t_{DGL1(LOWV)}$ ,  $t_{DGL2(LOWV)}$





## 10 Application and Implementation

### NOTE

Information in the following applications sections is not part of the TI component specification, and TI does not warrant its accuracy or completeness. TI's customers are responsible for determining suitability of components for their purposes. Customers should validate and test their design implementation to confirm system functionality.

### 10.1 Application Information

The bq2407x devices power the system while simultaneously and independently charging the battery. The input power source for charging the battery and running the system can be an AC adapter or a USB port. The devices feature dynamic power-path management (DPPM), which shares the source current between the system and battery charging and automatically reduces the charging current if the system load increases. When charging from a USB port, the input dynamic power management (VIN-DPM) circuit reduces the input current limit if the input voltage falls below a threshold, preventing the USB port from crashing. The power-path architecture also permits the battery to supplement the system current requirements when the adapter cannot deliver the peak system currents.

The bq2407x is configurable to be host controlled for selecting different input current limits based on the input source connected, or a fully stand alone device for applications that do not support multiple types of input sources.

### 10.2 Typical Application

$V_{IN} = UVLO$  to  $V_{OVP}$ ,  $I_{FASTCHG} = 800$  mA,  $I_{IN(MAX)} = 1.3$  A, Battery Temperature Charge Range =  $0^{\circ}\text{C}$  to  $50^{\circ}\text{C}$ , 6.25-hour Fastcharge Safety Timer

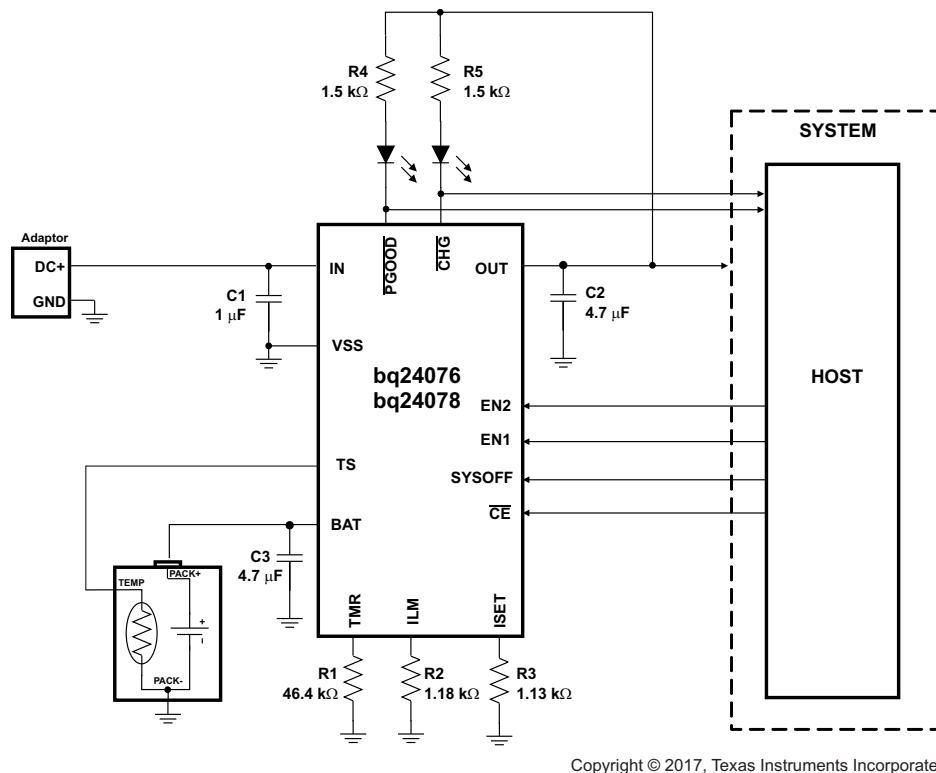

Copyright © 2017, Texas Instruments Incorporated

**Figure 26. Using bq24076/bq24078 in a Host-Controlled Charger Application**

## Typical Application (continued)

### 10.2.1 Design Requirements

- Supply voltage = 5 V
- Fast charge current of approximately 800 mA; ISET - pin 16
- Input current limit = 1.3 A; ILIM - pin 12
- Termination current threshold = 110 mA; ITERM – pin 15 (bq24074 only)
- Safety timer duration, Fast-Charge = 6.25 hours; TMR – pin 14
- TS – Battery Temperature Sense = 10 kΩ NTC (103AT-2)

### 10.2.2 Detailed Design Procedure

#### 10.2.2.1 bq2407x Charger Design Example

See [Figure 26](#) for a schematic of the design example.

##### 10.2.2.1.1 System ON/OFF (SYSOFF) (bq24076 or bq24078 only)

Connect SYSOFF high to disconnect the battery from the system load. Connect SYSOFF low for normal operation

#### 10.2.2.2 Calculations

##### 10.2.2.2.1 Program the Fast Charge Current (ISET):

$$R_{ISET} = K_{ISET} / I_{CHG}$$

$K_{ISET} = 890 \text{ A}\Omega$  from the electrical characteristics table.

$$R_{ISET} = 890 \text{ A}\Omega / 0.8 \text{ A} = 1.1125 \text{ k}\Omega$$

Select the closest standard value, which for this case is 1.13 kΩ. Connect this resistor between ISET (pin 16) and  $V_{SS}$ .

##### 10.2.2.2.2 Program the Input Current Limit (ILIM)

$$R_{ILIM} = K_{ILIM} / I_{L\_MAX}$$

$K_{ILIM} = 1550 \text{ A}\Omega$  from the electrical characteristics table.

$$R_{ISET} = 1550 \text{ A}\Omega / 1.3 \text{ A} = 1.192 \text{ k}\Omega$$

Select the closest standard value, which for this case is 1.18 kΩ. Connect this resistor between ILIM (pin 12) and  $V_{SS}$ .

##### 10.2.2.2.3 Program 6.25-hour Fast-Charge Safety Timer (TMR)

$$R_{TMR} = t_{MAXCHG} / (10 \times K_{TMR})$$

$K_{TMR} = 48 \text{ s/k}\Omega$  from the electrical characteristics table.

$$R_{TMR} = (6.25 \text{ hr} \times 3600 \text{ s/hr}) / (10 \times 48 \text{ s/k}\Omega) = 46.8 \text{ k}\Omega$$

Select the closest standard value, which for this case is 46.4 kΩ. Connect this resistor between TMR (pin 2) and  $V_{SS}$ .

#### 10.2.2.3 TS Function

Use a 10-kΩ NTC thermistor in the battery pack (103AT-2). For applications that do not require the TS monitoring function, connect a 10-kΩ resistor from TS to  $V_{SS}$  to set the TS voltage at a valid level and maintain charging.

#### 10.2.2.4 $\overline{CHG}$ and $\overline{PGOOD}$

LED Status: Connect a 1.5-kΩ resistor in series with a LED between  $\overline{OUT}$  and  $\overline{CHG}$  to indicate charging status. Connect a 1.5-kΩ resistor in series with a LED between  $\overline{OUT}$  and  $\overline{PGOOD}$  to indicate when a valid input source is connected.

## Typical Application (continued)

Processor Monitoring Status: Connect a pullup resistor (on the order of 100 k $\Omega$ ) between the power rail of the processor and  $\overline{\text{CHG}}$  and  $\overline{\text{PGOOD}}$ .

### 10.2.2.5 Selecting IN, OUT, and BAT Pin Capacitors

In most applications, all that is needed is a high-frequency decoupling capacitor (ceramic) on the power pin, input, output and battery pins. Using the values shown on the application diagram, is recommended. After evaluation of these voltage signals with real system operational conditions, one can determine if capacitance values can be adjusted toward the minimum recommended values (DC load application) or higher values for fast high amplitude pulsed load applications. Note if designed high input voltage sources (bad adaptors or wrong adaptors), the capacitor needs to be rated appropriately. Ceramic capacitors are tested to 2x their rated values so a 16-V capacitor may be adequate for a 30-V transient (verify tested rating with capacitor manufacturer).

**Typical Application (continued)**

**10.2.3 Application Curves**

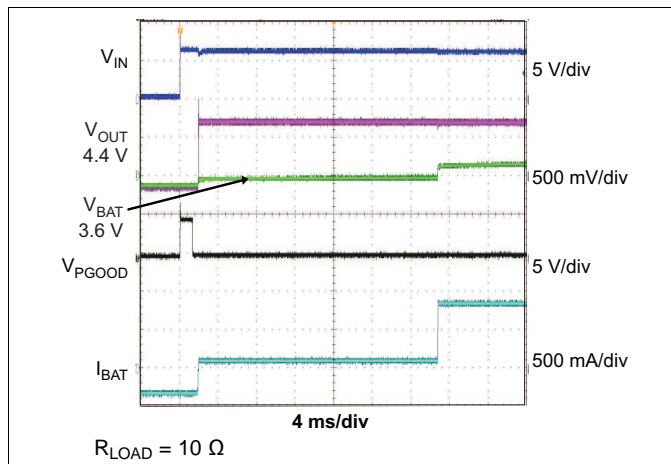

**Figure 27. Adapter Plug-In Battery Connected**

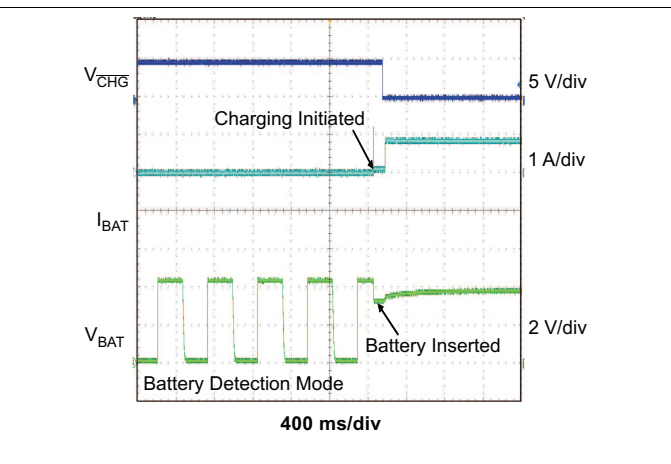

**Figure 28. Battery Detection Battery Inserted**

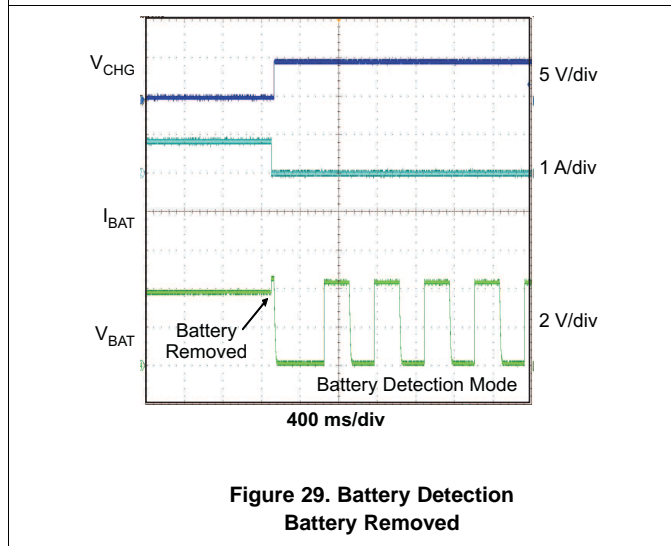

**Figure 29. Battery Detection Battery Removed**

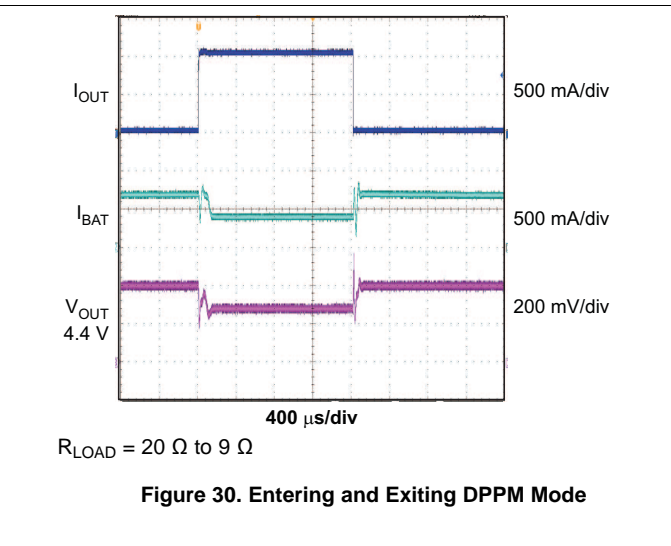

**Figure 30. Entering and Exiting DPPM Mode**

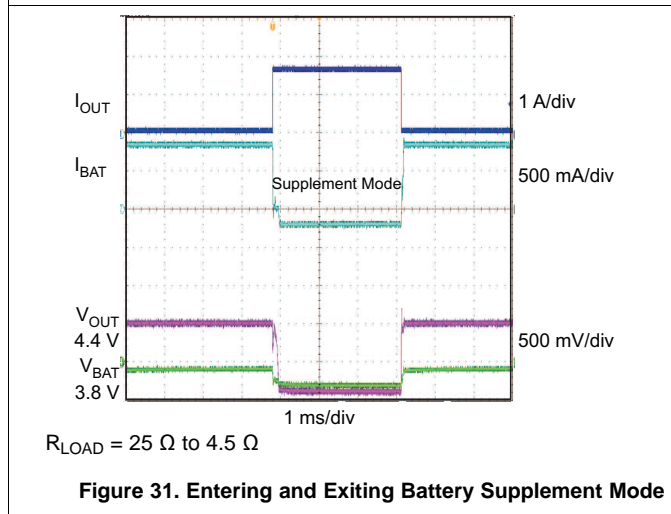

**Figure 31. Entering and Exiting Battery Supplement Mode**

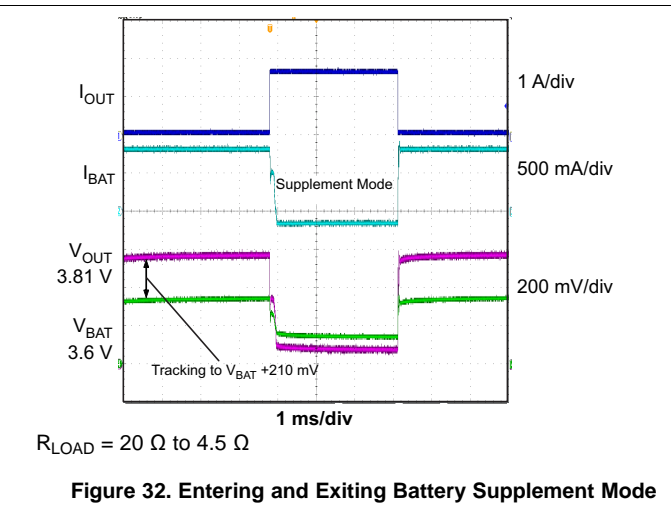

**Figure 32. Entering and Exiting Battery Supplement Mode**

Typical Application (continued)

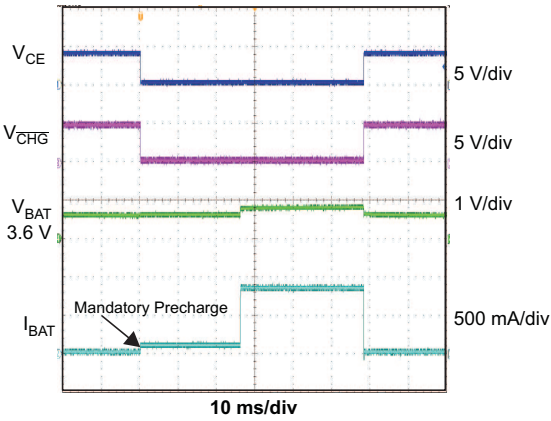

Figure 33. Charger ON/OFF Using  $\overline{CE}$

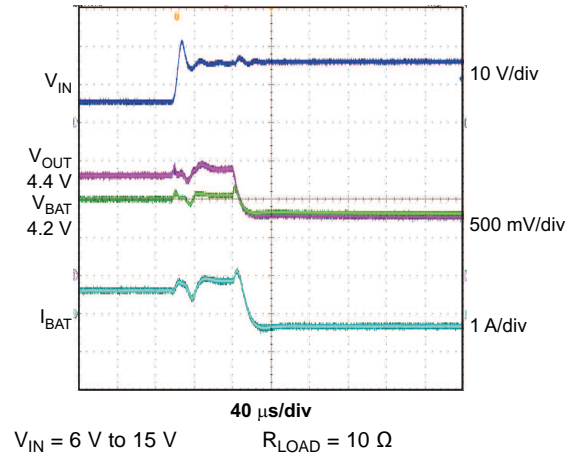

Figure 34. OVP Fault

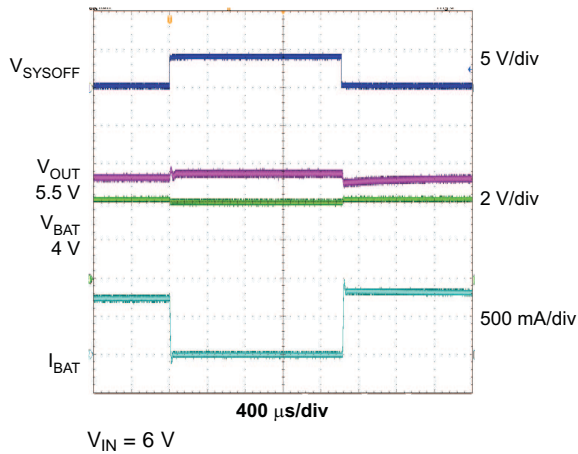

Figure 35. System ON/OFF With Input Connected  
bq24076, bq24078

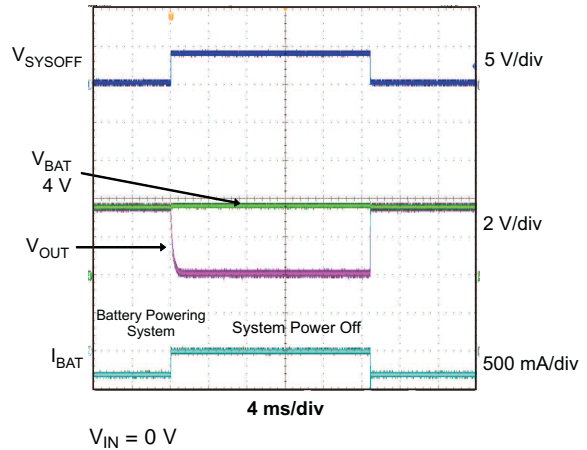

Figure 36. System ON/OFF With Input Not Connected  
bq24076, bq24078

## 11 Power Supply Recommendations

Some adapters implement a half rectifier topology, which causes the adapter output voltage to fall below the battery voltage during part of the cycle. To enable operation with adapters under those conditions, the bq2407x family keeps the charger on for at least 20 msec (typical) after the input power puts the part in sleep mode. This feature enables use of external adapters using 50 Hz networks. The input must not drop below the UVLO voltage for the charger to work properly. Thus, the battery voltage should be above the UVLO to help prevent the input from dropping out. Additional input capacitance may be needed.

## 12 Layout

### 12.1 Layout Guidelines

- To obtain optimal performance, the decoupling capacitor from IN to GND (thermal pad) and the output filter capacitors from OUT to GND (thermal pad) should be placed as close as possible to the bq2407x, with short trace runs to both IN, OUT and GND (thermal pad).
- All low-current GND connections should be kept separate from the high-current charge or discharge paths from the battery. Use a single-point ground technique incorporating both the small signal ground path and the power ground path.
- The high current charge paths into IN pin and from the OUT pin must be sized appropriately for the maximum charge current in order to avoid voltage drops in these traces
- The bq2407x family is packaged in a thermally enhanced MLP package. The package includes a thermal pad to provide an effective thermal contact between the IC and the printed circuit board (PCB); this thermal pad is also the main ground connection for the device. Connect the thermal pad to the PCB ground connection. Full PCB design guidelines for this package are provided in *QFN/SON PCB Attachment Application Note (SLUA271)*.

## 12.2 Layout Example

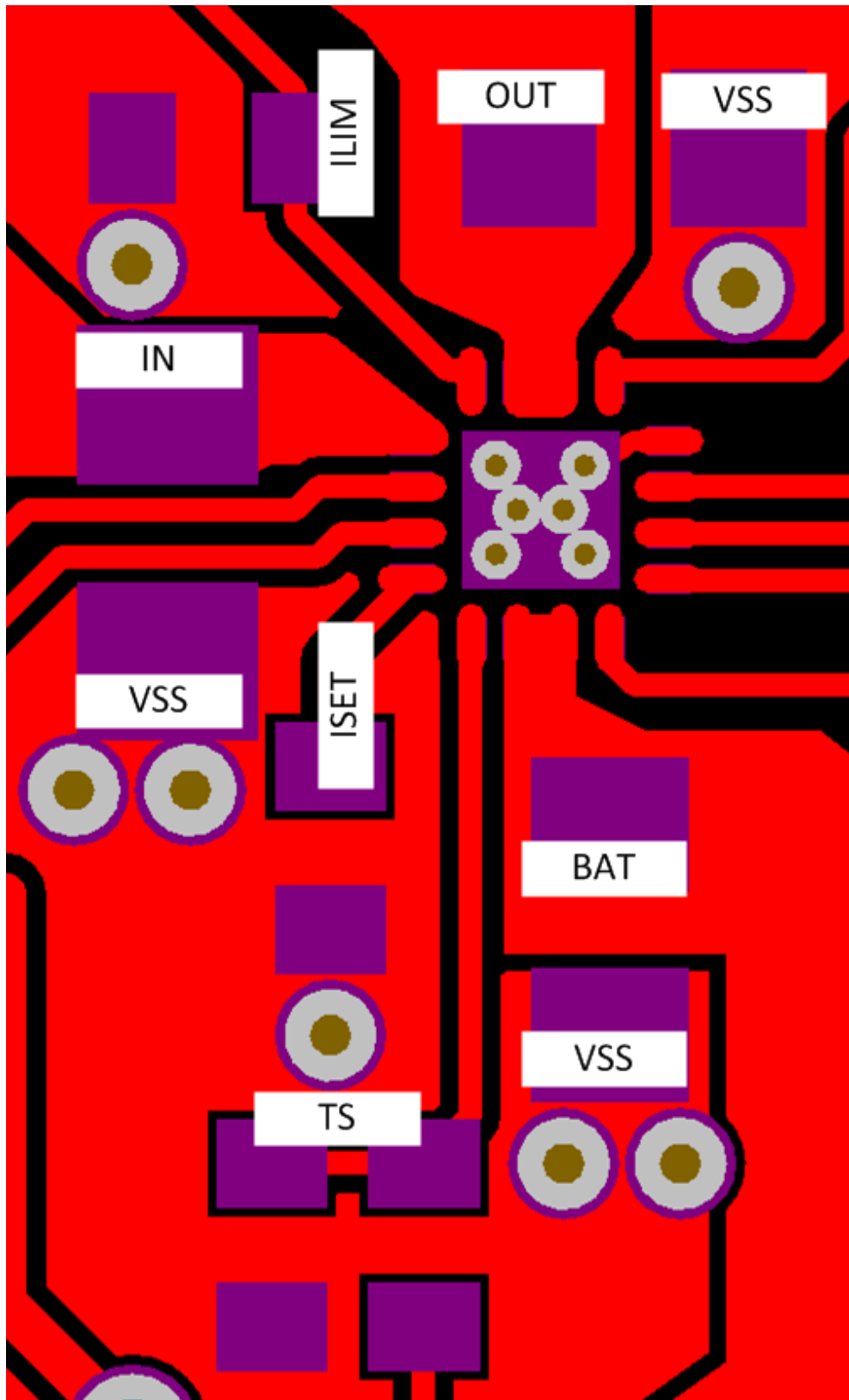

Figure 37. Layout Schematic



### 12.3 Thermal Considerations

The bq24076/78 family is packaged in a thermally enhanced MLP package. The package includes a thermal pad to provide an effective thermal contact between the IC and the printed circuit board (PCB). The power pad should be directly connected to the  $V_{SS}$  pin. Full PCB design guidelines for this package are provided in *QFN/SON PCB Attachment Application Note (SLUA271)*. The most common measure of package thermal performance is thermal impedance ( $\theta_{JA}$ ) measured (or modeled) from the chip junction to the air surrounding the package surface (ambient). The mathematical expression for  $\theta_{JA}$  is:

$$\theta_{JA} = (T_J - T) / P$$

where

- $T_J$  = chip junction temperature
- $T$  = ambient temperature
- $P$  = device power dissipation

(8)

Factors that can influence the measurement and calculation of  $\theta_{JA}$  include:

- Whether or not the device is board mounted
- Trace size, composition, thickness, and geometry
- Orientation of the device (horizontal or vertical)
- Volume of the ambient air surrounding the device under test and airflow
- Whether other surfaces are in close proximity to the device being tested

Due to the charge profile of Li-Ion batteries the maximum power dissipation is typically seen at the beginning of the charge cycle when the battery voltage is at its lowest. Typically after fast charge begins the pack voltage increases to  $\approx 3.4$  V within the first 2 minutes. The thermal time constant of the assembly typically takes a few minutes to heat up so when doing maximum power dissipation calculations, 3.4 V is a good minimum voltage to use. This is verified, with the system and a fully discharged battery, by plotting temperature on the bottom of the PCB under the IC (pad should have multiple vias), the charge current and the battery voltage as a function of time. The fast charge current will start to taper off if the part goes into thermal regulation.

The device power dissipation,  $P$ , is a function of the charge rate and the voltage drop across the internal PowerFET. It can be calculated from the following equation when a battery pack is being charged :

$$P = [V_{(IN)} - V_{(OUT)}] \times I_{(OUT)} + [V_{(OUT)} - V_{(BAT)}] \times I_{(BAT)}$$

(9)

The thermal loop feature reduces the charge current to limit excessive IC junction temperature. It is recommended that the design not run in thermal regulation for typical operating conditions (nominal input voltage and nominal ambient temperatures) and use the feature for non typical situations such as hot environments or higher than normal input source voltage. With that said, the IC will still perform as described, if the thermal loop is always active.

## 13 器件和文档支持

### 13.1 器件支持

#### 13.1.1 Third-Party Products Disclaimer

TI'S PUBLICATION OF INFORMATION REGARDING THIRD-PARTY PRODUCTS OR SERVICES DOES NOT CONSTITUTE AN ENDORSEMENT REGARDING THE SUITABILITY OF SUCH PRODUCTS OR SERVICES OR A WARRANTY, REPRESENTATION OR ENDORSEMENT OF SUCH PRODUCTS OR SERVICES, EITHER ALONE OR IN COMBINATION WITH ANY TI PRODUCT OR SERVICE.

### 13.2 相关链接

下面的表格列出了快速访问链接。类别包括技术文档、支持与社区资源、工具和软件，以及申请样片或购买产品的快速链接。

表 5. 相关链接

| 器件      | 产品文件夹                 | 立即订购                  | 技术文档                  | 工具和软件                 | 支持和社区                 |
|---------|-----------------------|-----------------------|-----------------------|-----------------------|-----------------------|
| bq24076 | <a href="#">请单击此处</a> | <a href="#">请单击此处</a> | <a href="#">请单击此处</a> | <a href="#">请单击此处</a> | <a href="#">请单击此处</a> |
| bq24078 | <a href="#">请单击此处</a> | <a href="#">请单击此处</a> | <a href="#">请单击此处</a> | <a href="#">请单击此处</a> | <a href="#">请单击此处</a> |

### 13.3 接收文档更新通知

要接收文档更新通知，请导航至 [TI.com](http://TI.com) 上的器件产品文件夹。单击右上角的 [通知我](#) 进行注册，即可每周接收产品信息更改摘要。有关更改的详细信息，请查看任何已修订文档中包含的修订历史记录。

### 13.4 社区资源

下列链接提供到 TI 社区资源的连接。链接的内容由各个分销商“按照原样”提供。这些内容并不构成 TI 技术规范，并且不一定反映 TI 的观点；请参阅 TI 的 [《使用条款》](#)。

**TI E2E™ 在线社区** [TI 的工程师对工程师 \(E2E\) 社区](#)。此社区的创建目的在于促进工程师之间的协作。在 [e2e.ti.com](http://e2e.ti.com) 中，您可以咨询问题、分享知识、拓展思路并与同行工程师一道帮助解决问题。

**设计支持** [TI 参考设计支持](#) 可帮助您快速查找有帮助的 E2E 论坛、设计支持工具以及技术支持的联系信息。

### 13.5 商标

E2E is a trademark of Texas Instruments.  
All other trademarks are the property of their respective owners.

### 13.6 静电放电警告



这些装置包含有限的内置 ESD 保护。存储或装卸时，应将导线一起截短或将装置放置于导电泡棉中，以防止 MOS 门极遭受静电损伤。

### 13.7 Glossary

[SLYZ022](#) — *TI Glossary*.

This glossary lists and explains terms, acronyms, and definitions.

## 14 机械、封装和可订购信息

以下页面包含机械、封装和可订购信息。这些信息是指定器件的最新可用数据。数据如有变更，恕不另行通知和修订此文档。如欲获取此产品说明书的浏览器版本，请参阅左侧的导航。

**PACKAGING INFORMATION**

| Orderable part number       | Status<br>(1) | Material type<br>(2) | Package   Pins  | Package qty   Carrier | RoHS<br>(3) | Lead finish/<br>Ball material<br>(4) | MSL rating/<br>Peak reflow<br>(5) | Op temp (°C) | Part marking<br>(6) |
|-----------------------------|---------------|----------------------|-----------------|-----------------------|-------------|--------------------------------------|-----------------------------------|--------------|---------------------|
| <a href="#">BQ24076RGTR</a> | Active        | Production           | VQFN (RGT)   16 | 3000   LARGE T&R      | Yes         | NIPDAU                               | Level-2-260C-1 YEAR               | -40 to 85    | B24076              |
| BQ24076RGTR.B               | Active        | Production           | VQFN (RGT)   16 | 3000   LARGE T&R      | Yes         | NIPDAU                               | Level-2-260C-1 YEAR               | -40 to 85    | B24076              |
| <a href="#">BQ24076RGTT</a> | Active        | Production           | VQFN (RGT)   16 | 250   SMALL T&R       | Yes         | NIPDAU                               | Level-2-260C-1 YEAR               | -40 to 85    | B24076              |
| BQ24076RGTT.B               | Active        | Production           | VQFN (RGT)   16 | 250   SMALL T&R       | Yes         | NIPDAU                               | Level-2-260C-1 YEAR               | -40 to 85    | B24076              |
| <a href="#">BQ24078RGTR</a> | Active        | Production           | VQFN (RGT)   16 | 3000   LARGE T&R      | Yes         | NIPDAU                               | Level-2-260C-1 YEAR               | -40 to 85    | B24078              |
| BQ24078RGTR.B               | Active        | Production           | VQFN (RGT)   16 | 3000   LARGE T&R      | Yes         | NIPDAU                               | Level-2-260C-1 YEAR               | -40 to 85    | B24078              |
| <a href="#">BQ24078RGTT</a> | Active        | Production           | VQFN (RGT)   16 | 250   SMALL T&R       | Yes         | NIPDAU                               | Level-2-260C-1 YEAR               | -40 to 85    | B24078              |
| BQ24078RGTT.B               | Active        | Production           | VQFN (RGT)   16 | 250   SMALL T&R       | Yes         | NIPDAU                               | Level-2-260C-1 YEAR               | -40 to 85    | B24078              |

(1) **Status:** For more details on status, see our [product life cycle](#).

(2) **Material type:** When designated, preproduction parts are prototypes/experimental devices, and are not yet approved or released for full production. Testing and final process, including without limitation quality assurance, reliability performance testing, and/or process qualification, may not yet be complete, and this item is subject to further changes or possible discontinuation. If available for ordering, purchases will be subject to an additional waiver at checkout, and are intended for early internal evaluation purposes only. These items are sold without warranties of any kind.

(3) **RoHS values:** Yes, No, RoHS Exempt. See the [TI RoHS Statement](#) for additional information and value definition.

(4) **Lead finish/Ball material:** Parts may have multiple material finish options. Finish options are separated by a vertical ruled line. Lead finish/Ball material values may wrap to two lines if the finish value exceeds the maximum column width.

(5) **MSL rating/Peak reflow:** The moisture sensitivity level ratings and peak solder (reflow) temperatures. In the event that a part has multiple moisture sensitivity ratings, only the lowest level per JEDEC standards is shown. Refer to the shipping label for the actual reflow temperature that will be used to mount the part to the printed circuit board.

(6) **Part marking:** There may be an additional marking, which relates to the logo, the lot trace code information, or the environmental category of the part.

Multiple part markings will be inside parentheses. Only one part marking contained in parentheses and separated by a "-" will appear on a part. If a line is indented then it is a continuation of the previous line and the two combined represent the entire part marking for that device.

**Important Information and Disclaimer:** The information provided on this page represents TI's knowledge and belief as of the date that it is provided. TI bases its knowledge and belief on information provided by third parties, and makes no representation or warranty as to the accuracy of such information. Efforts are underway to better integrate information from third parties. TI has taken and continues to take reasonable steps to provide representative and accurate information but may not have conducted destructive testing or chemical analysis on incoming materials and chemicals. TI and TI suppliers consider certain information to be proprietary, and thus CAS numbers and other limited information may not be available for release.

In no event shall TI's liability arising out of such information exceed the total purchase price of the TI part(s) at issue in this document sold by TI to Customer on an annual basis.

**TAPE AND REEL INFORMATION**

**QUADRANT ASSIGNMENTS FOR PIN 1 ORIENTATION IN TAPE**

\*All dimensions are nominal

| Device      | Package Type | Package Drawing | Pins | SPQ  | Reel Diameter (mm) | Reel Width W1 (mm) | A0 (mm) | B0 (mm) | K0 (mm) | P1 (mm) | W (mm) | Pin1 Quadrant |
|-------------|--------------|-----------------|------|------|--------------------|--------------------|---------|---------|---------|---------|--------|---------------|
| BQ24076RGTR | VQFN         | RGT             | 16   | 3000 | 330.0              | 12.4               | 3.3     | 3.3     | 1.1     | 8.0     | 12.0   | Q2            |
| BQ24076RGTT | VQFN         | RGT             | 16   | 250  | 180.0              | 12.5               | 3.3     | 3.3     | 1.1     | 8.0     | 12.0   | Q2            |
| BQ24078RGTR | VQFN         | RGT             | 16   | 3000 | 330.0              | 12.4               | 3.3     | 3.3     | 1.1     | 8.0     | 12.0   | Q2            |
| BQ24078RGTT | VQFN         | RGT             | 16   | 250  | 180.0              | 12.5               | 3.3     | 3.3     | 1.1     | 8.0     | 12.0   | Q2            |

## TAPE AND REEL BOX DIMENSIONS



\*All dimensions are nominal

| Device      | Package Type | Package Drawing | Pins | SPQ  | Length (mm) | Width (mm) | Height (mm) |
|-------------|--------------|-----------------|------|------|-------------|------------|-------------|
| BQ24076RGTR | VQFN         | RGT             | 16   | 3000 | 338.0       | 355.0      | 50.0        |
| BQ24076RGTT | VQFN         | RGT             | 16   | 250  | 205.0       | 200.0      | 33.0        |
| BQ24078RGTR | VQFN         | RGT             | 16   | 3000 | 338.0       | 355.0      | 50.0        |
| BQ24078RGTT | VQFN         | RGT             | 16   | 250  | 205.0       | 200.0      | 33.0        |

**RGT 16**

**GENERIC PACKAGE VIEW**

**VQFN - 1 mm max height**

PLASTIC QUAD FLATPACK - NO LEAD



Images above are just a representation of the package family, actual package may vary.  
Refer to the product data sheet for package details.

4203495/1

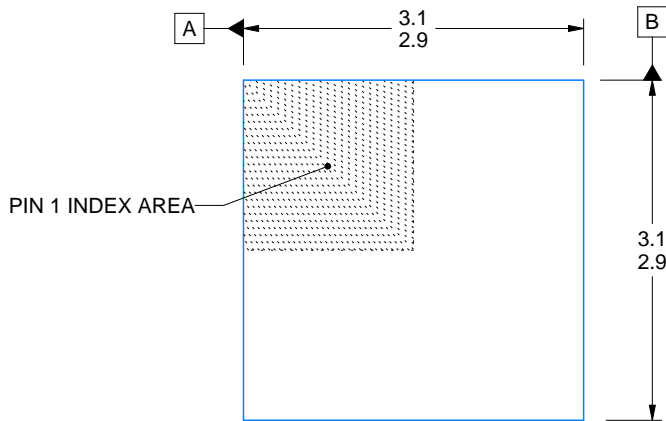
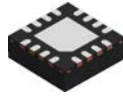

| SIDE WALL METAL THICKNESS DIM A |          |
|---------------------------------|----------|
| OPTION 1                        | OPTION 2 |
| 0.1                             | 0.2      |

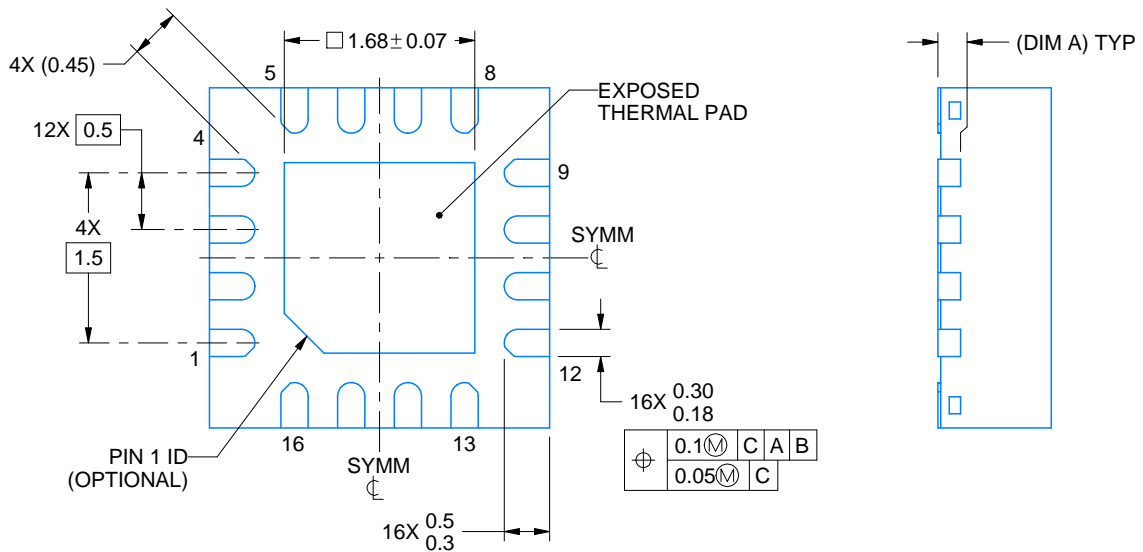
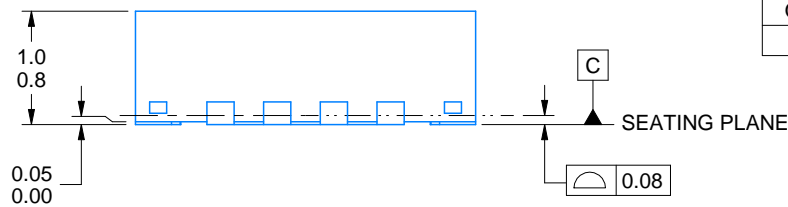

4222419/E 07/2025

NOTES:

1. All linear dimensions are in millimeters. Any dimensions in parenthesis are for reference only. Dimensioning and tolerancing per ASME Y14.5M.
2. This drawing is subject to change without notice.
3. The package thermal pad must be soldered to the printed circuit board for thermal and mechanical performance.





# EXAMPLE STENCIL DESIGN

RGT0016C

VQFN - 1 mm max height

PLASTIC QUAD FLATPACK - NO LEAD

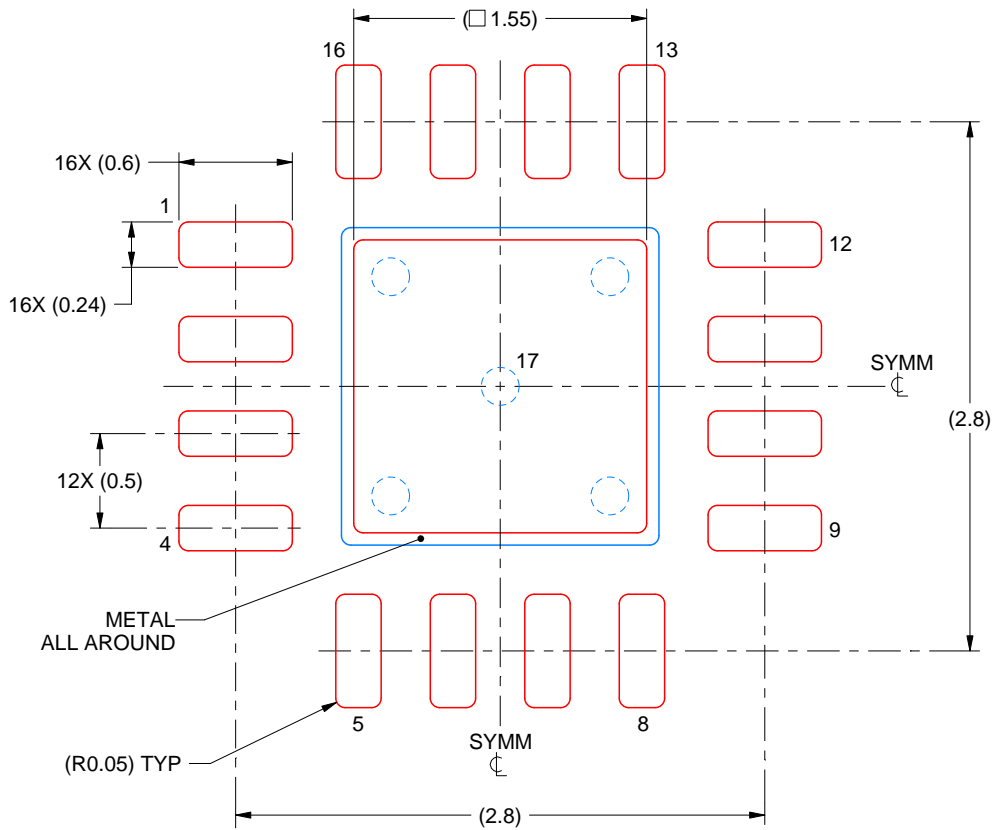

**SOLDER PASTE EXAMPLE**  
BASED ON 0.125 mm THICK STENCIL

EXPOSED PAD 17:  
85% PRINTED SOLDER COVERAGE BY AREA UNDER PACKAGE  
SCALE:25X

4222419/E 07/2025

NOTES: (continued)

6. Laser cutting apertures with trapezoidal walls and rounded corners may offer better paste release. IPC-7525 may have alternate design recommendations.

## 重要通知和免责声明

TI“按原样”提供技术和可靠性数据（包括数据表）、设计资源（包括参考设计）、应用或其他设计建议、网络工具、安全信息和其他资源，不保证没有瑕疵且不做任何明示或暗示的担保，包括但不限于对适销性、与某特定用途的适用性或不侵犯任何第三方知识产权的暗示担保。

这些资源可供使用 TI 产品进行设计的熟练开发人员使用。您将自行承担以下全部责任：(1) 针对您的应用选择合适的 TI 产品，(2) 设计、验证并测试您的应用，(3) 确保您的应用满足相应标准以及任何其他安全、安保法规或其他要求。

这些资源如有变更，恕不另行通知。TI 授权您仅可将这些资源用于研发本资源所述的 TI 产品的相关应用。严禁以其他方式对这些资源进行复制或展示。您无权使用任何其他 TI 知识产权或任何第三方知识产权。对于因您对这些资源的使用而对 TI 及其代表造成的任何索赔、损害、成本、损失和债务，您将全额赔偿，TI 对此概不负责。

TI 提供的产品受 [TI 销售条款](#)、[TI 通用质量指南](#) 或 [ti.com](#) 上其他适用条款或 TI 产品随附的其他适用条款的约束。TI 提供这些资源并不会扩展或以其他方式更改 TI 针对 TI 产品发布的适用的担保或担保免责声明。除非德州仪器 (TI) 明确将某产品指定为定制产品或客户特定产品，否则其产品均为按确定价格收入目录的标准通用器件。

TI 反对并拒绝您可能提出的任何其他或不同的条款。

版权所有 © 2025，德州仪器 (TI) 公司

最后更新日期：2025 年 10 月