

# ADS1259-Q1 汽车用, 14.4kSPS, 24 位模数转换器 具有集成低漂移基准

## 1 特性

- 符合汽车应用要求
- 具有符合 AEC-Q100 的下列结果:
  - 温度等级:  $-40^{\circ}\text{C}$  至  $125^{\circ}\text{C}$
  - 人体模型 (HBM) 静电放电 (ESD) 分类等级 2
  - 充电器件模型 (CDM) ESD 分类等级 C4B
- 可编程数据速率: 10SPS 至 14.4kSPS
- 单周期稳定数字滤波器
- 高性能:
  - 1.2kSPS 时的有效位数 (ENOB) 为 21.3
  - 积分非线性 (INL): 3ppm
  - 偏移漂移:  $0.05\mu\text{V}/^{\circ}\text{C}$
  - 增益漂移:  $0.5\text{ppm}/^{\circ}\text{C}$
- 内部基准: 2.5V, 漂移  $10\text{ppm}/^{\circ}\text{C}$
- 内部 2% 精准振荡器
- 输入信号超范围检测
- 可选校验和与冗余数据读取功能以增加数据完整性
- SPI™- 兼容接口, 模式 1
- 模拟电源: 5V 或者  $\pm 2.5\text{V}$
- 数字电源: 2.7V 至 5V

## 2 应用范围

- 汽车传动
- 电动汽车

## 3 说明

ADS1259-Q1 是一款精密, 低漂移, 24 位模数转换器 (ADC)。此器件可在数据速率高达 14.4kSPS 时执行高分辨率转换, 并因此非常适合于测量宽动态范围内快速变化的信号。一个集成的低噪声, 低漂移 2.5V 基准免除了对于外部电压基准的需要, 从而减少了系统成本和组件数量。

此转换器使用一个四阶、固有稳定、三角积分 ( $\Delta\Sigma$ ) 调制器, 此调制器提供出色的噪声性能和线性。此器件可将集成振荡器、外部晶振或外部时钟用作 ADC 时钟源。

一个快速响应输入超范围检测器标志是否出现一个输入超范围事件。为了增加嘈杂汽车应用环境中的数据完整性, ADS1259-Q1 提供一个可选校验和字节与一个冗余转换数据读取功能。

ADS1259-Q1 运行时的功率为 13mW, 而在节电模式下的功耗少于  $25\mu\text{W}$ 。TI 提供的 ADS1259-Q1 器件采用薄型小外形尺寸 (TSSOP)-20 封装, 可在  $-40^{\circ}\text{C}$  至  $125^{\circ}$  的温度范围内完全额定运行。

### 器件信息

订货编号	封装	封装尺寸
ADS1259QPWRQ1	TSSOP (20)	6.5mm x 4.4mm

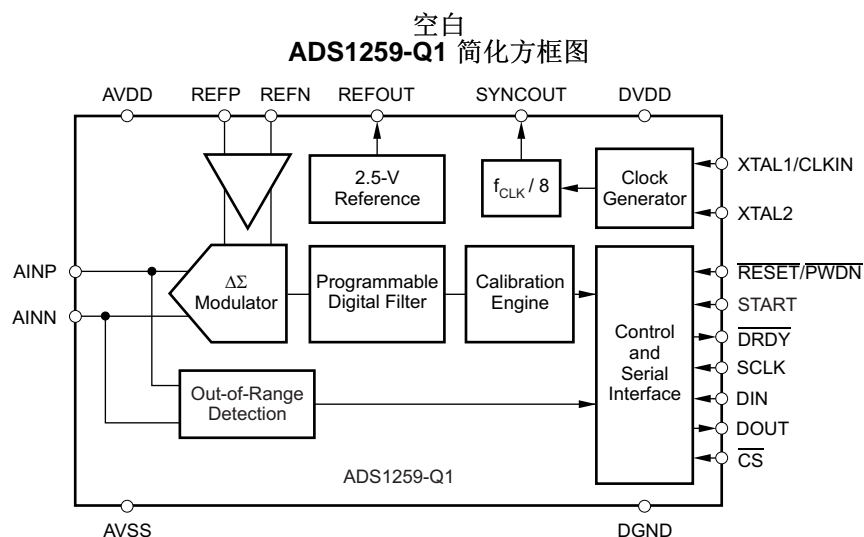

## 目录

<p><b>1</b> 特性 ..... 1</p> <p><b>2</b> 应用范围 ..... 1</p> <p><b>3</b> 说明 ..... 1</p> <p><b>4</b> 修订历史记录 ..... 2</p> <p><b>5</b> <b>Terminal Configuration and Functions</b> ..... 3</p> <p><b>6</b> <b>Specifications</b> ..... 4</p> <p style="padding-left: 20px;">6.1 Absolute Maximum Ratings ..... 4</p> <p style="padding-left: 20px;">6.2 Handling Ratings ..... 4</p> <p style="padding-left: 20px;">6.3 Recommended Operating Conditions ..... 5</p>	<p>6.4 Thermal Information ..... 5</p> <p>6.5 Electrical Characteristics ..... 6</p> <p><b>7</b> <b>Residue</b> ..... 7</p> <p><b>8</b> 器件文档和支持 ..... 8</p> <p style="padding-left: 20px;">8.1 Trademarks ..... 8</p> <p style="padding-left: 20px;">8.2 Electrostatic Discharge Caution ..... 8</p> <p style="padding-left: 20px;">8.3 Glossary ..... 8</p> <p><b>9</b> 机械封装和可订购信息 ..... 9</p>
---	---

## 4 修订历史记录

日期	修订版本	注释
2014 年 3 月	*	最初发布版本

## 5 Terminal Configuration and Functions

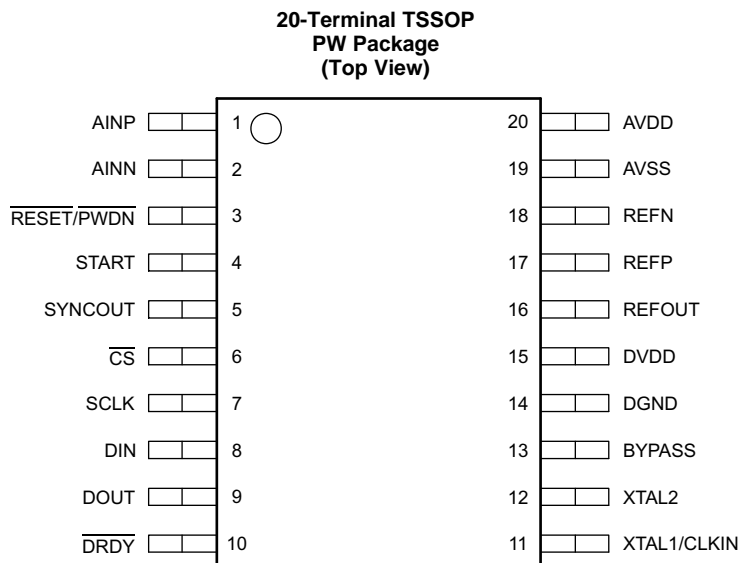

### Terminal Functions

TERMINAL		TYPE	DESCRIPTION
NO.	NAME		
1	AINP	Analog input	Positive analog input
2	AINN	Analog input	Negative analog input
3	$\overline{\text{RESET/PWDN}}$	Digital input	Reset or power down; reset is active-low; hold low for power down.
4	START	Digital input	Start conversions, active-high
5	SYNCOUT	Digital output	Sync clock output ( $f_{(\text{CLK})} / 8$ )
6	$\overline{\text{CS}}$	Digital input	SPI chip-select, active-low
7	SCLK	Digital input	SPI clock input
8	DIN	Digital input	SPI data input
9	DOUT	Digital output	SPI data output
10	$\overline{\text{DRDY}}$	Digital output	Data-ready output, active-low
11	XTAL1/CLKIN	Digital input	Internal oscillator: DGND External clock: clock input Crystal oscillator: external crystal1
12	XTAL2	Digital	External crystal2, otherwise no connection
13	BYPASS	Analog	Core voltage bypass. Connect a 1- $\mu\text{F}$ capacitor to DGND.
14	DGND	Digital	Digital ground
15	DVDD	Digital	Digital power supply
16	REFOUT	Analog output	Positive internal reference output. Connect a 1- $\mu\text{F}$ capacitor, $C_{\text{REFOUT}}$ , to AVSS.
17	REFP	Analog input	Positive reference input. Connect a 1- $\mu\text{F}$ capacitor, $C_{\text{REFIN}}$ , to REFN. <sup>(1)</sup>
18	REFN	Analog input	Negative reference input <sup>(1)</sup>
19	AVSS	Analog	Negative analog power supply and negative internal reference output
20	AVDD	Analog	Positive analog power supply

(1) Leave unused reference inputs unconnected or tie to AVDD.

## 6 Specifications

### 6.1 Absolute Maximum Ratings<sup>(1)</sup>

over operating ambient temperature range (unless otherwise noted)

		MIN	MAX	UNIT
AVDD to AVSS		-0.3	7	V
AVSS to DGND		-2.8	0.3	V
DVDD to DGND		-0.3	7	V
Analog input voltage	AINN, AINP, REFN, REFP	AVSS - 0.3	AVDD + 0.3	V
Digital input voltage	$\overline{CS}$ , DIN, RESET/PDWN, SCLK, START, XTAL1/CLKIN	DGND - 0.3	DVDD + 0.3	V
Input current, continuous	Any terminal except supply terminals	-10	10	mA
Operating junction temperature, T <sub>J</sub>		-40	150	°C

- (1) Stresses beyond those listed under *Absolute Maximum Ratings* may cause permanent damage to the device. These are stress ratings only, which do not imply functional operation of the device at these or any other conditions beyond those indicated under *Recommended Operating Conditions*. Exposure to absolute-maximum-rated conditions for extended periods may affect device reliability.

### 6.2 Handling Ratings

		MIN	MAX	UNIT
T <sub>stg</sub>	Storage temperature range	-60	150	°C
V <sub>(ESD)</sub> <sup>(1)</sup>	Human-body model (HBM) ESD stress voltage <sup>(2)</sup>	-2	2	kV
	Charged-device model (CDM) ESD stress voltage <sup>(2)</sup>	-1	1	kV

- (1) Electrostatic discharge (ESD) to measure device sensitivity or immunity to damage caused by assembly-line electrostatic discharges into the device.
- (2) Meets or exceeds the passing level per AEC-Q100.

### 6.3 Recommended Operating Conditions

over operating ambient temperature range (unless otherwise noted)

		MIN	NOM	MAX	UNIT
<b>POWER SUPPLY</b>					
Analog power supply	AVDD to AVSS	4.75	5.0	5.25	V
	AVSS to DGND	-2.6	-2.5	0	V
Digital power supply	DVDD to DGND	2.7	3.3	5.25	V
<b>ANALOG INPUTS</b>					
Absolute input voltage	AINP or AINN	AVSS - 0.1		AVDD + 0.1	V
Differential input voltage <sup>(1)</sup>	$V_{(IN)} = (V_{(AINP)} - V_{(AINN)})$	-V <sub>ref</sub>		V <sub>ref</sub>	V
<b>VOLTAGE REFERENCE INPUTS</b>					
Reference input voltage	$V_{ref} = (V_{(REFP)} - V_{(REFN)})$	0.5	2.5	AVDD - AVSS + 0.2	V
Absolute negative reference voltage	REFN	AVSS - 0.1	AVSS	REFP - 0.5	V
Absolute positive reference voltage	REFP	REFN + 0.5	AVSS + 2.5	AVDD + 0.1	V
<b>EXTERNAL CLOCK SOURCES (f<sub>(CLK)</sub>)</b>					
Crystal oscillator	Frequency	2	7.3728	8	MHz
External clock	Frequency	0.1	7.3728	8	MHz
	Duty cycle	40%		60%	
<b>DIGITAL INPUTS</b>					
High-level input voltage, V <sub>IH</sub>		0.8 DVDD		DVDD	V
Low-level input voltage, V <sub>IL</sub>		DGND		0.2 DVDD	V
<b>TEMPERATURE RANGE</b>					
Operating ambient temperature, T <sub>A</sub>		-40		125	°C

(1) Excluding the effects of offset and gain error.

### 6.4 Thermal Information

THERMAL METRIC <sup>(1)</sup>		PW (20 TERMINALS)	UNIT
R <sub>θJA</sub>	Junction-to-ambient thermal resistance	86.9	°C/W
R <sub>θJC(top)</sub>	Junction-to-case (top) thermal resistance	21	°C/W
R <sub>θJB</sub>	Junction-to-board thermal resistance	39.1	°C/W
ψ <sub>JT</sub>	Junction-to-top characterization parameter	0.8	°C/W
ψ <sub>JB</sub>	Junction-to-board characterization parameter	38.4	°C/W
R <sub>θJC(bot)</sub>	Junction-to-case (bottom) thermal resistance	N/A	°C/W

(1) For more information about traditional and new thermal metrics, see the *IC Package Thermal Metrics* application report, [SPRA953](#).

## 6.5 Electrical Characteristics

Minimum and maximum specifications are at  $T_A = -40^\circ\text{C}$  to  $125^\circ\text{C}$ . Typical specifications are at  $T_A = 25^\circ\text{C}$ ,  $AVDD = 2.5\text{ V}$ ,  $AVSS = -2.5\text{ V}$ ,  $DVDD = 3.3\text{ V}$ , external  $f_{\text{CLK}} = 7.3728\text{ MHz}$ , external  $V_{\text{ref}} = 2.5\text{ V}$ , and  $f_{\text{DATA}} = 60\text{ SPS}$  (unless otherwise noted)

PARAMETER	TEST CONDITIONS	MIN	TYP	MAX	UNIT
<b>ANALOG INPUTS</b>					
Differential input impedance			120		k $\Omega$
Common-mode input impedance			500		k $\Omega$
<b>SYSTEM PERFORMANCE</b>					
Resolution (no missing codes)		24			Bits
Data rate, $f_{\text{DATA}}$		10		14,400	SPS
Noise (input referred)	Shorted inputs, See SBAS424 for more information.		0.7		$\mu\text{V}_{\text{RMS}}$
Integral nonlinearity, INL	Best-fit method	-10	$\pm 3$	10	ppm
Offset voltage (input referred)		-250	$\pm 40$	250	$\mu\text{V}$
Offset voltage after calibration <sup>(1)</sup>			$\pm 1$		$\mu\text{V}$
Offset drift	$T_A = -40^\circ\text{C}$ to $125^\circ\text{C}$		0.05	0.25	$\mu\text{V}/^\circ\text{C}$
Gain error <sup>(2)</sup>		-0.5%	$\pm 0.05\%$	0.5%	
Gain error after calibration <sup>(1)</sup>			$\pm 0.0002\%$		
Gain drift	$T_A = -40^\circ\text{C}$ to $125^\circ\text{C}$		0.5	2.5	ppm/ $^\circ\text{C}$
Normal-mode rejection ratio, NMRR		See SBAS424.			
Common-mode rejection ratio, CMRR	60 Hz, ac <sup>(3)</sup>	100	120		dB
AVDD, AVSS power-supply rejection ratio, PSRR	60 Hz, ac <sup>(3)</sup>	85	95		dB
DVDD power supply-rejection ratio, PSRR	60 Hz, ac <sup>(3)</sup>	85	110		dB
<b>OUT-OF-RANGE DETECTION</b>					
Threshold level	$AVSS + 150\text{ mV} \leq V_{\text{(AINP)}}; V_{\text{(AINN)}} \leq AVDD - 150\text{ mV}$		$\pm 105$		%FSR
Threshold level accuracy	$AVSS + 150\text{ mV} \leq V_{\text{(AINP)}}; V_{\text{(AINN)}} \leq AVDD - 150\text{ mV}$		$\pm 0.5$		%FSR
<b>VOLTAGE REFERENCE INPUTS</b>					
Average reference input current	$AVSS \leq V_{\text{(REFP)}}; V_{\text{(REFN)}} \leq AVDD$		350		nA
Average reference input current drift			0.2		nA/ $^\circ\text{C}$
<b>INTERNAL VOLTAGE REFERENCE</b>					
Reference output voltage	$V_{\text{(REFOUT)}} = (\text{REFOUT} - AVSS)$		2.5		V
Accuracy	$T_A = 25^\circ\text{C}$	-0.4%		0.4%	
Temperature drift	$T_A = -40^\circ\text{C}$ to $125^\circ\text{C}$		10	40	ppm/ $^\circ\text{C}$
Drive current (sink and source)		-10		10	mA
Load regulation			10		$\mu\text{V}/\text{mA}$
Turn-on settling time	$\pm 0.001\%$ settling, $C_{\text{REFIN}} = 1\ \mu\text{F}$ , $C_{\text{REFOUT}} = 1\ \mu\text{F}$		1		s
Long-term stability	0 to 1000 hours		70		ppm
Thermal hysteresis			30		ppm
<b>CLOCK SOURCE (<math>f_{\text{CLK}}</math>)</b>					
Internal oscillator frequency			7.3728		MHz
Internal oscillator accuracy		-2%	$\pm 0.2\%$	2%	
External crystal oscillator start-up time <sup>(4)</sup>	18-pF load capacitors		20		ms
<b>DIGITAL INPUTS AND OUTPUTS (DVDD = 2.7 V to 5.25 V)</b>					
High-level output voltage, $V_{\text{OH}}$	$I_{\text{OH}} = 1\text{ mA}$	0.8 DVDD			V
	$I_{\text{OH}} = 8\text{ mA}$	0.75 DVDD			
Low-level output voltage, $V_{\text{OL}}$	$I_{\text{OL}} = 1\text{ mA}$	0.2 DVDD			V
	$I_{\text{OL}} = 8\text{ mA}$	0.2 DVDD			
Input hysteresis			0.1		V
Input leakage	$0 < V_{\text{(DIGITAL INPUT)}} < DVDD$	-10		10	$\mu\text{A}$

(1) Calibration accuracy is on the level of noise (signal and ADC), reduced by the effect of 16-reading averaging.

(2) Excludes internal reference error.

(3)  $f_{\text{DATA}} = 14.4\text{ kSPS}$ . Placing a notch of the digital filter at 60 Hz (setting  $f_{\text{DATA}} = 10\text{ SPS}$  or  $60\text{ SPS}$ ) further improves the common-mode rejection and power-supply rejection of this input frequency.

(4) External crystal start-up time can vary with crystal manufacturer and over temperature.

## Electrical Characteristics (continued)

Minimum and maximum specifications are at  $T_A = -40^{\circ}\text{C}$  to  $125^{\circ}\text{C}$ . Typical specifications are at  $T_A = 25^{\circ}\text{C}$ ,  $AVDD = 2.5\text{ V}$ ,  $AVSS = -2.5\text{ V}$ ,  $DVDD = 3.3\text{ V}$ , external  $f_{\text{CLK}} = 7.3728\text{ MHz}$ , external  $V_{\text{ref}} = 2.5\text{ V}$ , and  $f_{\text{DATA}} = 60\text{ SPS}$  (unless otherwise noted)

PARAMETER	TEST CONDITIONS	MIN	TYP	MAX	UNIT
<b>POWER SUPPLY</b>					
Absolute analog supply current (AVDD, AVSS)	Operating (internal reference enabled)		2.3	5	mA
	Standby mode (internal reference enabled)		200		μA
	Standby mode (internal reference disabled)		1		
	Power-down mode		1		
Digital supply current (DVDD)	Operating (internal oscillator <sup>(5)</sup> )		500	700	μA
	Standby mode (internal oscillator)		160	300	
	Power-down mode (external CLKIN, SCLK stopped, digital inputs maintained at $V_{\text{IH}}$ or $V_{\text{IL}}$ voltage levels)		1	10	
Power dissipation	Operating (internal reference enabled, internal oscillator)		13	28	mW
	Standby mode (internal reference enabled, internal oscillator)		1.5		
	Standby mode (internal reference disabled, internal oscillator)		0.5		
	Power-down mode		10		μW

(5) Internal oscillator current: 40 μA (typ.)

## 7 Residue

See [SBAS424](#) for any information on the ADS1259-Q1 device that is not covered in the foregoing sections.

## 8 器件文档和支持

### 8.1 Trademarks

SPI is a trademark of Motorola.

All other trademarks are the property of their respective owners.

### 8.2 Electrostatic Discharge Caution



This integrated circuit can be damaged by ESD. Texas Instruments recommends that all integrated circuits be handled with appropriate precautions. Failure to observe proper handling and installation procedures can cause damage.

ESD damage can range from subtle performance degradation to complete device failure. Precision integrated circuits may be more susceptible to damage because very small parametric changes could cause the device not to meet its published specifications.

### 8.3 Glossary

[SLYZ022](#) — *TI Glossary*.

This glossary lists and explains terms, acronyms and definitions.



## 9 机械封装和可订购信息

以下页中包括机械封装和可订购信息。 这些信息是针对指定器件可提供的最新数据。 这些数据会在无通知且不对本文档进行修订的情况下发生改变。 要获得这份数据表的浏览器版本，请查阅左侧导航栏。

**PACKAGING INFORMATION**

Orderable Device	Status (1)	Package Type	Package Drawing	Pins	Package Qty	Eco Plan (2)	Lead finish/ Ball material (6)	MSL Peak Temp (3)	Op Temp (°C)	Device Marking (4/5)	Samples
ADS1259QPWRQ1	ACTIVE	TSSOP	PW	20	2000	RoHS & Green	NIPDAU	Level-1-260C-UNLIM	-40 to 125	AD1259Q1	Samples

(1) The marketing status values are defined as follows:

**ACTIVE:** Product device recommended for new designs.

**LIFEBUY:** TI has announced that the device will be discontinued, and a lifetime-buy period is in effect.

**NRND:** Not recommended for new designs. Device is in production to support existing customers, but TI does not recommend using this part in a new design.

**PREVIEW:** Device has been announced but is not in production. Samples may or may not be available.

**OBSOLETE:** TI has discontinued the production of the device.

(2) **RoHS:** TI defines "RoHS" to mean semiconductor products that are compliant with the current EU RoHS requirements for all 10 RoHS substances, including the requirement that RoHS substance do not exceed 0.1% by weight in homogeneous materials. Where designed to be soldered at high temperatures, "RoHS" products are suitable for use in specified lead-free processes. TI may reference these types of products as "Pb-Free".

**RoHS Exempt:** TI defines "RoHS Exempt" to mean products that contain lead but are compliant with EU RoHS pursuant to a specific EU RoHS exemption.

**Green:** TI defines "Green" to mean the content of Chlorine (Cl) and Bromine (Br) based flame retardants meet JS709B low halogen requirements of <=1000ppm threshold. Antimony trioxide based flame retardants must also meet the <=1000ppm threshold requirement.

(3) MSL, Peak Temp. - The Moisture Sensitivity Level rating according to the JEDEC industry standard classifications, and peak solder temperature.

(4) There may be additional marking, which relates to the logo, the lot trace code information, or the environmental category on the device.

(5) Multiple Device Markings will be inside parentheses. Only one Device Marking contained in parentheses and separated by a "-" will appear on a device. If a line is indented then it is a continuation of the previous line and the two combined represent the entire Device Marking for that device.

(6) Lead finish/Ball material - Orderable Devices may have multiple material finish options. Finish options are separated by a vertical ruled line. Lead finish/Ball material values may wrap to two lines if the finish value exceeds the maximum column width.

**Important Information and Disclaimer:**The information provided on this page represents TI's knowledge and belief as of the date that it is provided. TI bases its knowledge and belief on information provided by third parties, and makes no representation or warranty as to the accuracy of such information. Efforts are underway to better integrate information from third parties. TI has taken and continues to take reasonable steps to provide representative and accurate information but may not have conducted destructive testing or chemical analysis on incoming materials and chemicals. TI and TI suppliers consider certain information to be proprietary, and thus CAS numbers and other limited information may not be available for release.

In no event shall TI's liability arising out of such information exceed the total purchase price of the TI part(s) at issue in this document sold by TI to Customer on an annual basis.

PW0020A



# PACKAGE OUTLINE

## TSSOP - 1.2 mm max height

SMALL OUTLINE PACKAGE



4220206/A 02/2017

### NOTES:

1. All linear dimensions are in millimeters. Any dimensions in parenthesis are for reference only. Dimensioning and tolerancing per ASME Y14.5M.
2. This drawing is subject to change without notice.
3. This dimension does not include mold flash, protrusions, or gate burrs. Mold flash, protrusions, or gate burrs shall not exceed 0.15 mm per side.
4. This dimension does not include interlead flash. Interlead flash shall not exceed 0.25 mm per side.
5. Reference JEDEC registration MO-153.

# EXAMPLE BOARD LAYOUT

PW0020A

TSSOP - 1.2 mm max height

SMALL OUTLINE PACKAGE



LAND PATTERN EXAMPLE  
EXPOSED METAL SHOWN  
SCALE: 10X



SOLDER MASK DETAILS

4220206/A 02/2017

NOTES: (continued)

- 6. Publication IPC-7351 may have alternate designs.
- 7. Solder mask tolerances between and around signal pads can vary based on board fabrication site.

# EXAMPLE STENCIL DESIGN

PW0020A

TSSOP - 1.2 mm max height

SMALL OUTLINE PACKAGE



SOLDER PASTE EXAMPLE  
BASED ON 0.125 mm THICK STENCIL  
SCALE: 10X

4220206/A 02/2017

NOTES: (continued)

8. Laser cutting apertures with trapezoidal walls and rounded corners may offer better paste release. IPC-7525 may have alternate design recommendations.
9. Board assembly site may have different recommendations for stencil design.

## 重要声明和免责声明

TI“按原样”提供技术和可靠性数据（包括数据表）、设计资源（包括参考设计）、应用或其他设计建议、网络工具、安全信息和其他资源，不保证没有瑕疵且不做任何明示或暗示的担保，包括但不限于对适销性、某特定用途方面的适用性或不侵犯任何第三方知识产权的暗示担保。

这些资源可供使用 TI 产品进行设计的熟练开发人员使用。您将自行承担以下全部责任：(1) 针对您的应用选择合适的 TI 产品，(2) 设计、验证并测试您的应用，(3) 确保您的应用满足相应标准以及任何其他功能安全、信息安全、监管或其他要求。

这些资源如有变更，恕不另行通知。TI 授权您仅可将这些资源用于研发本资源所述的 TI 产品的应用。严禁对这些资源进行其他复制或展示。您无权使用任何其他 TI 知识产权或任何第三方知识产权。您应全额赔偿因在这些资源的使用中对 TI 及其代表造成的任何索赔、损害、成本、损失和债务，TI 对此概不负责。

TI 提供的产品受 [TI 的销售条款](#) 或 [ti.com](#) 上其他适用条款/TI 产品随附的其他适用条款的约束。TI 提供这些资源并不会扩展或以其他方式更改 TI 针对 TI 产品发布的适用的担保或担保免责声明。

TI 反对并拒绝您可能提出的任何其他或不同的条款。

邮寄地址：Texas Instruments, Post Office Box 655303, Dallas, Texas 75265

Copyright © 2024，德州仪器 (TI) 公司