

## 单通道 5Ω SP3T 模拟开关 5V/3.3V 3:1 多路复用器/多路信号分离器

### 1 特性

- 指定的先断后合开关
- 低导通状态电阻
- 高带宽
- 控制输入可承受 5.5V 电压
- 低电荷注入
- 出色的通态电阻匹配
- 低总谐波失真 (THD)
- 1.65V 至 5.5V 单电源运行
- 锁断性能超过 100mA (符合 JESD 78, II 类规范的要求)
- 静电放电 (ESD) 性能测试符合 JESD 22 规范
  - 2000V 人体放电模式 (A114-B, II 类)
  - 1000V 充电器件模型 (C101)

### 2 应用

- 手机
- 掌上电脑 (PDA)
- 便携式仪表

### 3 说明

TS5A3357 是一款高性能单通道 3:1 模拟开关, 可在 1.65V 至 5.5V 电压范围内运行。该器件可提供低导通状态电阻和低输入/输出电容, 因此具有低信号失真。先断后合功能允许在信号失真极低的情况下将信号从一个端口传输到另一个端口。该器件还可提供低电荷注入, 因此适用于高性能音频和数据收集系统。

#### 器件信息(1)

器件型号	封装	封装尺寸 (标称值)
TS5A3357	VSSOP (8)	2.3mm x 2mm

(1) 如需了解所有可用封装, 请参阅产品说明书末尾的可订购产品附录。

逻辑图

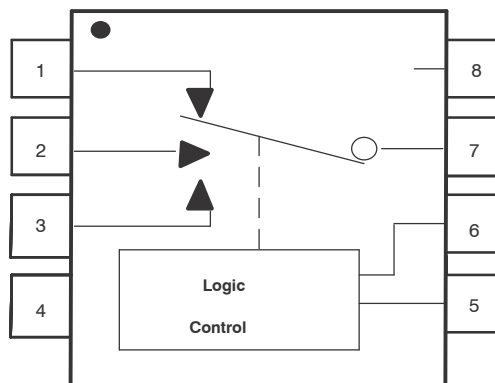

## 目录

<b>1</b>	特性 .....	1	9.2	Functional Block Diagram .....	20
<b>2</b>	应用 .....	1	9.3	Feature Description .....	20
<b>3</b>	说明 .....	1	9.4	Device Functional Modes .....	20
<b>4</b>	修订历史记录 .....	2	<b>10</b>	<b>Application and Implementation</b> .....	21
<b>5</b>	<b>Device Comparison Table</b> .....	3	10.1	Application Information .....	21
<b>6</b>	<b>Pin Configuration and Functions</b> .....	4	10.2	Typical Application .....	21
<b>7</b>	<b>Specifications</b> .....	5	<b>11</b>	<b>Power Supply Recommendations</b> .....	22
7.1	Absolute Maximum Ratings .....	5	<b>12</b>	<b>Layout</b> .....	23
7.2	ESD Ratings .....	5	12.1	Layout Guidelines .....	23
7.3	Recommended Operating Conditions .....	5	12.2	Layout Example .....	23
7.4	Thermal Information .....	5	<b>13</b>	<b>器件和文档支持</b> .....	24
7.5	Electrical Characteristics for 5-V Supply .....	6	13.1	器件支持 .....	24
7.6	Electrical Characteristics for 3.3-V Supply .....	8	13.2	文档支持 .....	24
7.7	Electrical Characteristics for 2.5-V Supply .....	10	13.3	接收文档更新通知 .....	24
7.8	Electrical Characteristics for 1.8-V Supply .....	12	13.4	社区资源 .....	24
7.9	Typical Characteristics .....	14	13.5	商标 .....	24
<b>8</b>	<b>Parameter Measurement Information</b> .....	16	13.6	静电放电警告 .....	24
<b>9</b>	<b>Detailed Description</b> .....	20	13.7	术语表 .....	24
9.1	Overview .....	20	<b>14</b>	<b>机械、封装和可订购信息</b> .....	24

## 4 修订历史记录

注：之前版本的页码可能与当前版本有所不同。

### Changes from Revision A (December 2007) to Revision B

Page

- 增加了器件信息表、ESD 额定值表、建议运行条件表、特性说明部分、器件功能模式、应用和实施部分、电源建议部分、布局部分、器件和文档支持部分以及机械、封装和可订购信息部分 .....

1

## 5 Device Comparison Table

**Table 1. Summary of Characteristics<sup>(1)</sup>**

Configuration	Triple 3:1 Multiplexer/ Demultiplexer (1 × SP3T)
Number of channels	1
ON-state resistance ( $r_{on}$ )	5 $\Omega$
ON-state resistance match ( $\Delta r_{on}$ )	0.1 $\Omega$
ON-state resistance flatness ( $r_{on(flat)}$ )	6.5 $\Omega$
Turn-on/turn-off time ( $t_{ON}/t_{OFF}$ )	6.5 ns/3.7 ns
Break-before-make time ( $t_{BBM}$ )	0.5 ns
Charge injection ( $Q_C$ )	3.4 pC
Bandwidth (BW)	334 MHz
OFF isolation ( $O_{ISO}$ )	–82 dB at 10 MHz
Crosstalk ( $X_{TALK}$ )	–62 dB at 10 MHz
Total harmonic distortion (THD)	0.05%
Leakage current ( $I_{COM(OFF)}$ )	$\pm 1 \mu A$

(1)  $V_+ = 5 V$ ,  $T_A = 25^\circ C$

## 6 Pin Configuration and Functions

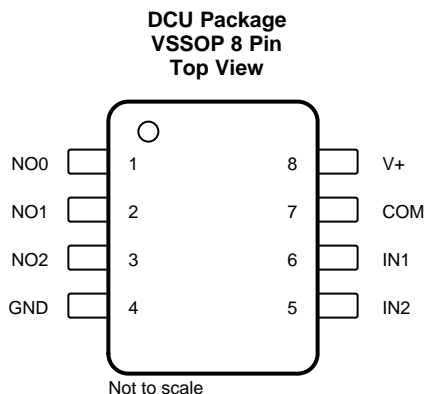

### Pin Functions

PIN		DESCRIPTION
NAME	NO.	
NO0	1	Normally open
NO1	2	Normally open
NO2	3	Normally open
GND	4	Digital ground
IN2	5	Digital control to connect COM to NO
IN1	6	Digital control to connect COM to NO
COM	7	Common
V+	8	Power supply

## 7 Specifications

### 7.1 Absolute Maximum Ratings

over operating free-air temperature range (unless otherwise noted)<sup>(1)</sup>

		MIN	MAX	UNIT
V <sub>+</sub>	Supply voltage range <sup>(2)</sup>	-0.5	6.5	V
V <sub>NO</sub> V <sub>COM</sub>	Analog voltage range <sup>(2) (3) (4)</sup>	-0.5	V <sub>+</sub> + 0.5	V
I <sub>K</sub>	Analog port diode current	V <sub>NO</sub> , V <sub>COM</sub> < 0 or V <sub>NO</sub> , V <sub>COM</sub> > V <sub>+</sub>		mA
I <sub>NO</sub> I <sub>COM</sub>	On-state switch current	V <sub>NO</sub> , V <sub>COM</sub> = 0 to V <sub>+</sub>		mA
V <sub>I</sub>	Digital input voltage range <sup>(2) (3)</sup>	-0.5	6.5	V
I <sub>IK</sub>	Digital input clamp current	V <sub>I</sub> < 0		mA
I <sub>+</sub>	Continuous current through V <sub>+</sub>		100	mA
I <sub>GND</sub>	Continuous current through GND	-100	100	mA
T <sub>stg</sub>	Storage temperature range	-65	150	°C

- (1) Stresses beyond those listed under *Absolute Maximum Ratings* may cause permanent damage to the device. These are stress ratings only, which do not imply functional operation of the device at these or any other conditions beyond those indicated under *Recommended Operating Conditions*. Exposure to absolute-maximum-rated conditions for extended periods may affect device reliability.
- (2) All voltages are with respect to ground, unless otherwise specified.
- (3) The input and output voltage ratings may be exceeded if the input and output clamp-current ratings are observed.
- (4) This value is limited to 5.5 V maximum.

### 7.2 ESD Ratings

		VALUE	UNIT
V <sub>(ESD)</sub>	Electrostatic discharge	Human-body model (HBM), per ANSI/ESDA/JEDEC JS-001 <sup>(1)</sup>	V
		Charged-device model (CDM), per JEDEC specification JESD22-C101 <sup>(2)</sup>	

- (1) JEDEC document JEP155 states that 500-V HBM allows safe manufacturing with a standard ESD control process.
- (2) JEDEC document JEP157 states that 250-V CDM allows safe manufacturing with a standard ESD control process.

### 7.3 Recommended Operating Conditions

over operating free-air temperature range (unless otherwise noted)

		MIN	MAX	UNIT
V <sub>+</sub>	Supply voltage range	1.65	5.5	V
V <sub>NO</sub> V <sub>COM</sub>	Analog voltage range	0	V <sub>+</sub>	
V <sub>I</sub>	Digital input voltage range	0	5.5	

### 7.4 Thermal Information

THERMAL METRIC <sup>(1)</sup>		TS5A3357	
		DCU (VSSOP)	
		8 PINS	
R <sub>θJA</sub>	Junction-to-ambient thermal resistance	206.5	°C/W
R <sub>θJC(top)</sub>	Junction-to-case (top) thermal resistance	78.7	°C/W
R <sub>θJB</sub>	Junction-to-board thermal resistance	85.3	°C/W
ψ <sub>JT</sub>	Junction-to-top characterization parameter	7.3	°C/W
ψ <sub>JB</sub>	Junction-to-board characterization parameter	84.8	°C/W
R <sub>θJC(bot)</sub>	Junction-to-case (bottom) thermal resistance	n/a	°C/W

- (1) For more information about traditional and new thermal metrics, see the [Semiconductor and IC Package Thermal Metrics](#) application report.

## 7.5 Electrical Characteristics for 5-V Supply<sup>(1)</sup>

$V_+ = 4.5\text{ V to }5.5\text{ V}$ ,  $T_A = -40^\circ\text{C to }85^\circ\text{C}$  (unless otherwise noted)

PARAMETER	SYMBOL	TEST CONDITIONS	$T_A$	$V_+$	MIN	TYP	MAX	UNIT
<b>Analog Switch</b>								
Peak ON resistance	$r_{\text{peak}}$	$0 \leq V_{\text{NO}} \leq V_+$ , $I_{\text{COM}} = -30\text{ mA}$ ,	Switch ON, See <a href="#">Figure 13</a>	Full	4.5 V		15	$\Omega$
ON-state resistance	$r_{\text{on}}$	$V_{\text{NO}} = 0$ , $I_{\text{COM}} = 30\text{ mA}$	Switch ON, See <a href="#">Figure 13</a>	25°C	4.5 V		5	7
				Full			7	
		25°C				6	12	
		Full				12		
		$V_{\text{NO}} = 2.4\text{ V}$ , $I_{\text{COM}} = -30\text{ mA}$		25°C		7	15	
		$V_{\text{NO}} = 4.5\text{ V}$ , $I_{\text{COM}} = -30\text{ mA}$		Full		15		
ON-state resistance match between channels	$\Delta r_{\text{on}}$	$V_{\text{NO}} = 3.15\text{ V}$ , $I_{\text{COM}} = -30\text{ mA}$ ,	Switch ON, See <a href="#">Figure 13</a>	25°C	4.5 V	0.1		$\Omega$
ON-state resistance flatness	$r_{\text{on(flat)}}$	$0 \leq V_{\text{NO}} \leq V_+$ , $I_{\text{COM}} = -30\text{ mA}$ ,	Switch ON, See <a href="#">Figure 13</a>	25°C	5 V	6.5		$\Omega$
NO OFF leakage current	$I_{\text{NO(OFF)}}$	$V_{\text{NO}} = 0\text{ to }V_+$ , $V_{\text{COM}} = V_+\text{ to }0$	Switch OFF, See <a href="#">Figure 14</a>	25°C	5.5 V	-0.1	0.1	$\mu\text{A}$
				Full		-1	1	
COM OFF leakage current	$I_{\text{COM(OFF)}}$	$V_{\text{COM}} = 0\text{ to }V_+$ , $V_{\text{NO}} = V_+\text{ to }0$ ,	Switch OFF, See <a href="#">Figure 14</a>	25°C	0	-0.1	0.1	$\mu\text{A}$
				Full		-1	1	
NO ON leakage current	$I_{\text{NO(ON)}}$	$V_{\text{NO}} = 0\text{ to }V_+$ , $V_{\text{COM}} = \text{Open}$ ,	Switch ON, See <a href="#">Figure 14</a>	25°C	5.5 V	-0.1	0.1	$\mu\text{A}$
				Full		-1	1	
COM ON leakage current	$I_{\text{COM(ON)}}$	$V_{\text{NO}} = \text{Open}$ , $V_{\text{COM}} = 0\text{ to }V_+$ ,	Switch ON, See <a href="#">Figure 14</a>	25°C	5.5 V	-0.1	0.1	$\mu\text{A}$
				Full		-1	1	
<b>Digital Control Inputs (IN1, IN2)<sup>(2)</sup></b>								
Input logic high	$V_{\text{IH}}$			Full		$V_+ \times 0.7$	5.5	V
Input logic low	$V_{\text{IL}}$			Full		0	$V_+ \times 0.3$	V
Input leakage current	$I_{\text{IH}}, I_{\text{IL}}$	$V_{\text{I}} = 5.5\text{ V or }0$		25°C	5.5 V		0.1	$\mu\text{A}$
				Full		1		

(1) The algebraic convention, whereby the most negative value is a minimum and the most positive value is a maximum

(2) All unused digital inputs of the device must be held at  $V_+$  or GND to ensure proper device operation. Refer to the TI application report, *Implications of Slow or Floating CMOS Inputs*, literature number SCBA004.

**Electrical Characteristics for 5-V Supply<sup>(1)</sup> (continued)**
 $V_+ = 4.5\text{ V to }5.5\text{ V}$ ,  $T_A = -40^\circ\text{C to }85^\circ\text{C}$  (unless otherwise noted)

PARAMETER	SYMBOL	TEST CONDITIONS	$T_A$	$V_+$	MIN	TYP	MAX	UNIT
<b>Dynamic</b>								
Turn-on time	$t_{ON}$	$V_{NO} = V_+$ or GND, $R_L = 500\ \Omega$ , See <a href="#">Figure 16</a>	25°C	5 V	1.5		6.5	ns
			Full	4.5 V to 5.5 V	1.5		7	
Turn-off time	$t_{OFF}$	$V_{NO} = V_+$ or GND, $R_L = 500\ \Omega$ , See <a href="#">Figure 16</a>	25°C	5 V	0.8		3.7	ns
			Full	4.5 V to 5.5 V	0.8		7	
Break-before-make time	$t_{BBM}$	$V_{NO} = V_+$ , $R_L = 50\ \Omega$ , See <a href="#">Figure 17</a>	25°C	5 V	0.5			ns
			Full	4.5 V to 5.5 V	0.5			
Charge injection	$Q_C$	$V_{GEN} = 0$ , $C_L = 0.1\text{ nF}$ , See <a href="#">Figure 21</a>	25°C	5 V		3.4		pC
NO OFF capacitance	$C_{NO(OFF)}$	$V_{NO} = V_+$ or GND, Switch OFF, See <a href="#">Figure 15</a>	25°C	5 V		4.5		pF
COM OFF capacitance	$C_{COM(OFF)}$	$V_{NO} = V_+$ or GND, Switch OFF, See <a href="#">Figure 15</a>	25°C	5 V		10.5		pF
NO ON capacitance	$C_{NO(ON)}$	$V_{NO} = V_+$ or GND, Switch ON, See <a href="#">Figure 15</a>	25°C	5 V		17		pF
COM ON capacitance	$C_{COM(ON)}$	$V_{COM} = V_+$ or GND, Switch ON, See <a href="#">Figure 15</a>	25°C	5 V		17		pF
Digital input capacitance	$C_I$	$V_I = V_+$ or GND, See <a href="#">Figure 15</a>	25°C	5 V		3		pF
Bandwidth	BW	$R_L = 50\ \Omega$ , Switch ON, See <a href="#">Figure 18</a>	25°C	4.5 V to 5.5 V		334		MHz
OFF isolation	$O_{ISO}$	$R_L = 50\ \Omega$ , $f = 10\text{ MHz}$ , Switch OFF, See <a href="#">Figure 19</a>	25°C	4.5 V to 5.5 V		-82		dB
Crosstalk	$X_{TALK}$	$R_L = 50\ \Omega$ , $f = 10\text{ MHz}$ , Switch ON, See <a href="#">Figure 20</a>	25°C	4.5 V to 5.5 V		-62		dB
<b>Supply</b>								
Positive supply current	$I_+$	$V_I = V_+$ or GND, Switch ON or OFF	25°C	5.5 V			1	$\mu\text{A}$
			Full				10	

### 7.6 Electrical Characteristics for 3.3-V Supply<sup>(1)</sup>

$V_+ = 3\text{ V to }3.6\text{ V}$ ,  $T_A = -40^\circ\text{C to }85^\circ\text{C}$  (unless otherwise noted)

PARAMETER	SYMBOL	TEST CONDITIONS	$T_A$	$V_+$	MIN	TYP	MAX	UNIT
<b>Analog Switch</b>								
Peak ON resistance	$r_{\text{peak}}$	$0 \leq V_{\text{NO}} \leq V_+$ , $I_{\text{COM}} = -24\text{ mA}$ , Switch ON, See <a href="#">Figure 13</a>	Full	3 V			25	$\Omega$
ON-state resistance	$r_{\text{on}}$	$V_{\text{NO}} = 0\text{ V}$ , $I_{\text{COM}} = 24\text{ mA}$ Switch ON, See <a href="#">Figure 13</a>	25°C	3 V			6.5	9
			Full				9	
			25°C				9	20
			Full				20	
ON-state resistance match between channels	$\Delta r_{\text{on}}$	$V_{\text{NO}} = 2.1\text{ V}$ , $I_{\text{COM}} = -24\text{ mA}$ , Switch ON, See <a href="#">Figure 13</a>	25°C	3 V		0.1	$\Omega$	
ON-state resistance flatness	$r_{\text{on(Flat)}}$	$0 \leq V_{\text{NO}} \leq V_+$ , $I_{\text{COM}} = -24\text{ mA}$ , Switch ON, See <a href="#">Figure 13</a>	25°C	3.3 V		13.5	$\Omega$	
NO OFF leakage current	$I_{\text{NO(OFF)}}$	$V_{\text{NO}} = 0\text{ to }V_+$ , $V_{\text{COM}} = V_+\text{ to }0$ , Switch OFF, See <a href="#">Figure 14</a>	25°C	3.6 V			-0.1	0.1
			Full				-1	1
COM OFF leakage current	$I_{\text{COM(OFF)}}$	$V_{\text{COM}} = 0\text{ to }V_+$ , $V_{\text{NO}} = V_+\text{ to }0$ , Switch OFF, See <a href="#">Figure 14</a>	25°C	3.6 V			-0.1	0.1
			Full				-1	1
NO ON leakage current	$I_{\text{NO(ON)}}$	$V_{\text{NO}} = 0\text{ to }V_+$ , $V_{\text{COM}} = V_+\text{ to }0$ , Switch ON, See <a href="#">Figure 14</a>	25°C	3.6 V			-0.1	0.1
			Full				-1	1
COM ON leakage current	$I_{\text{COM(ON)}}$	$V_{\text{NO}} = \text{Open}$ , $V_{\text{COM}} = 0\text{ to }V_+$ , Switch ON, See <a href="#">Figure 14</a>	25°C	3.6 V			-0.1	0.1
			Full				-1	1
<b>Digital Control Inputs (IN1, IN2)<sup>(2)</sup></b>								
Input logic high	$V_{\text{IH}}$		Full			$V_+ \times 0.7$	5.5	V
Input logic low	$V_{\text{IL}}$		Full			0	$V_+ \times 0.3$	V
Input leakage current	$I_{\text{IH}}, I_{\text{IL}}$	$V_{\text{I}} = 5.5\text{ V or }0$	25°C	3.6 V			-1	0.1
			Full				1	

- (1) The algebraic convention, whereby the most negative value is a minimum and the most positive value is a maximum
- (2) All unused digital inputs of the device must be held at  $V_+$  or GND to ensure proper device operation. Refer to the TI application report, *Implications of Slow or Floating CMOS Inputs*, literature number SCBA004.

**Electrical Characteristics for 3.3-V Supply<sup>(1)</sup> (continued)**
 $V_+ = 3\text{ V to }3.6\text{ V}$ ,  $T_A = -40^\circ\text{C to }85^\circ\text{C}$  (unless otherwise noted)

PARAMETER	SYMBOL	TEST CONDITIONS	$T_A$	$V_+$	MIN	TYP	MAX	UNIT
<b>Dynamic</b>								
Turn-on time	$t_{ON}$	$V_{NO} = V_+$ or GND, $R_L = 500\ \Omega$ ,	$C_L = 50\text{ pF}$ , See <a href="#">Figure 16</a>	25°C	3.3 V	2	9.5	ns
				Full	3 V to 3.6 V	2	11	
Turn-off time	$t_{OFF}$	$V_{NO} = V_+$ or GND, $R_L = 500\ \Omega$ ,	$C_L = 50\text{ pF}$ , See <a href="#">Figure 16</a>	25°C	3.3 V	1.3	5.1	ns
				Full	3 V to 3.6 V	1.5	5.5	
Break-before-make time	$t_{BBM}$	$V_{NO} = V_+$ , $R_L = 50\ \Omega$ ,	$C_L = 50\text{ pF}$ , See <a href="#">Figure 17</a>	25°C	3.3 V	0.5		ns
				Full	3 V to 3.6 V	0.5		
Charge injection	$Q_C$	$V_{GEN} = 0$ , $C_L = 0.1\text{ nF}$ ,	25°C	3.3 V		1.75		pC
NO OFF capacitance	$C_{NO(OFF)}$	$V_{NO} = V_+$ or GND, Switch OFF,	25°C	3.3 V		4.5		pF
COM OFF capacitance	$C_{COM(OFF)}$	$V_{NO} = V_+$ or GND, Switch OFF,	25°C	3.3 V		10.5		pF
NO ON capacitance	$C_{NO(ON)}$	$V_{NO} = V_+$ or GND, Switch ON,	25°C	3.3 V		17		pF
COM ON capacitance	$C_{COM(ON)}$	$V_{COM} = V_+$ or GND, Switch ON,	25°C	3.3 V		17		pF
Digital input capacitance	$C_I$	$V_I = V_+$ or GND,	25°C	3.3 V		3		pF
Bandwidth	BW	$R_L = 50\ \Omega$ , Switch ON,	25°C	3 V to 3.6 V		327		MHz
OFF isolation	$O_{ISO}$	$R_L = 50\ \Omega$ , $f = 10\text{ MHz}$ ,	25°C	3 V to 3.6 V		-82		dB
Crosstalk	$X_{TALK}$	$R_L = 50\ \Omega$ , $f = 10\text{ MHz}$ ,	25°C	3 V to 3.6 V		-62		dB
<b>Supply</b>								
Positive supply current	$I_+$	$V_I = V_+$ or GND, Switch ON or OFF	25°C	3.6 V			1	$\mu\text{A}$
			Full				10	

## 7.7 Electrical Characteristics for 2.5-V Supply<sup>(1)</sup>

$V_+ = 2.3 \text{ V to } 2.7 \text{ V}$ ,  $T_A = -40^\circ\text{C to } 85^\circ\text{C}$  (unless otherwise noted)

PARAMETER	SYMBOL	TEST CONDITIONS		$T_A$	$V_+$	MIN	TYP	MAX	UNIT
<b>Analog Switch</b>									
Analog signal range	$V_{COM}, V_{NO}$					0		$V_+$	V
Peak ON resistance	$r_{peak}$	$0 \leq V_{NO} \leq V_+$ , $I_{COM} = -8 \text{ mA}$	Switch ON, See Figure 13	Full	2.3 V			50	$\Omega$
ON-state resistance	$r_{on}$	$V_{NO} = 0 \text{ V}$ , $I_{COM} = 8 \text{ mA}$	Switch ON, See Figure 13	25°C	2.3 V	8		12	$\Omega$
				Full				12	
		25°C		11		30			
		Full				30			
ON-state resistance match between channels	$\Delta r_{on}$	$V_{NO} = 1.8 \text{ V}$ , $I_{COM} = -8 \text{ mA}$	Switch ON, See Figure 13	25°C	2.3 V	0.3		$\Omega$	
ON-state resistance flatness	$r_{on(Flat)}$	$0 \leq V_{NO} \leq V_+$ , $I_{COM} = -8 \text{ mA}$	Switch ON, See Figure 13	25°C	2.5 V	39		$\Omega$	
NO OFF leakage current	$I_{NO(OFF)}$	$V_{NO} = 0 \text{ to } V_+$ , $V_{COM} = V_+ \text{ to } 0$	Switch OFF, See Figure 14	25°C	2.7 V	-0.1		0.1	$\mu\text{A}$
				Full		-1		1	
COM OFF leakage current	$I_{COM(OFF)}$	$V_{COM} = 0 \text{ to } V_+$ , $V_{NO} = V_+ \text{ to } 0$	Switch OFF, See Figure 14	25°C	2.7 V	-0.1		0.1	$\mu\text{A}$
				Full		-1		1	
NO ON leakage current	$I_{NO(ON)}$	$V_{NO} = 0 \text{ to } V_+$ , $V_{COM} = V_+ \text{ to } 0$	Switch ON, See Figure 14	25°C	2.7 V	-0.1		0.1	$\mu\text{A}$
				Full		-1		1	
COM ON leakage current	$I_{COM(ON)}$	$V_{NO} = \text{Open}$ , $V_{COM} = 0 \text{ to } V_+$	Switch ON, See Figure 14	25°C	2.7 V	-0.1		0.1	$\mu\text{A}$
				Full		-1		1	
<b>Digital Control Inputs (IN1, IN2)<sup>(2)</sup></b>									
Input logic high	$V_{IH}$			Full		$V_+ \times 0.75$		5.5	V
Input logic low	$V_{IL}$			Full		0	$V_+ \times 0.25$		V
Input leakage current	$I_{IH}, I_{IL}$	$V_I = 5.5 \text{ V or } 0$		25°C	2.7 V			0.1	$\mu\text{A}$
				Full				1	

(1) The algebraic convention, whereby the most negative value is a minimum and the most positive value is a maximum

(2) All unused digital inputs of the device must be held at  $V_+$  or GND to ensure proper device operation. Refer to the TI application report, *Implications of Slow or Floating CMOS Inputs*, literature number SCBA004.

**Electrical Characteristics for 2.5-V Supply<sup>(1)</sup> (continued)**
 $V_+ = 2.3\text{ V to }2.7\text{ V}$ ,  $T_A = -40^\circ\text{C to }85^\circ\text{C}$  (unless otherwise noted)

PARAMETER	SYMBOL	TEST CONDITIONS	$T_A$	$V_+$	MIN	TYP	MAX	UNIT
<b>Dynamic</b>								
Turn-on time	$t_{ON}$	$V_{NO} = V_+$ or GND, $R_L = 500\ \Omega$ ,	$C_L = 50\text{ pF}$ , See <a href="#">Figure 16</a>	25°C	2.5 V	3	15	ns
				Full	2.3 V to 2.7 V	3	16.5	
Turn-off time	$t_{OFF}$	$V_{NO} = V_+$ or GND, $R_L = 500\ \Omega$ ,	$C_L = 50\text{ pF}$ , See <a href="#">Figure 16</a>	25°C	2.5 V	2	7.2	ns
				Full	2.3 V to 2.7 V	2	7.8	
Break-before-make time	$t_{BBM}$	$V_{NO} = V_+$ , $R_L = 50\ \Omega$ ,	$C_L = 50\text{ pF}$ , See <a href="#">Figure 17</a>	25°C	2.5 V	0.5		ns
				Full	2.3 V to 2.7 V	0.5		
Charge injection	$Q_C$	$V_{GEN} = 0$ , $C_L = 0.1\text{ nF}$ ,	See <a href="#">Figure 21</a>	25°C	2.5 V	1.15		pC
NO OFF capacitance	$C_{NO(OFF)}$	$V_{NO} = V_+$ or GND, Switch OFF,	See <a href="#">Figure 15</a>	25°C	2.5 V	4.5		pF
COM OFF capacitance	$C_{COM(OFF)}$	$V_{NO} = V_+$ or GND, Switch OFF,	See <a href="#">Figure 15</a>	25°C	2.5 V	10.5		pF
NO ON capacitance	$C_{NO(ON)}$	$V_{NO} = V_+$ or GND, Switch ON,	See <a href="#">Figure 15</a>	25°C	2.5 V	17		pF
COM ON capacitance	$C_{COM(ON)}$	$V_{COM} = V_+$ or GND, Switch ON,	See <a href="#">Figure 15</a>	25°C	2.5 V	17		pF
Digital input capacitance	$C_I$	$V_I = V_+$ or GND,	See <a href="#">Figure 15</a>	25°C	2.5 V	3		pF
Bandwidth	BW	$R_L = 50\ \Omega$ , Switch ON,	See <a href="#">Figure 18</a>	25°C	2.3 V to 2.7 V	320		MHz
OFF isolation	$O_{ISO}$	$R_L = 50\ \Omega$ , $f = 10\text{ MHz}$ ,	Switch OFF, See <a href="#">Figure 19</a>	25°C	2.3 V to 2.7 V	-81		dB
Crosstalk	$X_{TALK}$	$R_L = 50\ \Omega$ , $f = 10\text{ MHz}$ ,	Switch ON, See <a href="#">Figure 20</a>	25°C	2.3 V to 2.7 V	-61		dB
<b>Supply</b>								
Positive supply current	$I_+$	$V_I = V_+$ or GND,	Switch ON or OFF	25°C	2.7 V		1	$\mu\text{A}$
				Full			10	

## 7.8 Electrical Characteristics for 1.8-V Supply<sup>(1)</sup>

$V_+ = 1.65\text{ V to }1.95\text{ V}$ ,  $T_A = -40^\circ\text{C to }85^\circ\text{C}$  (unless otherwise noted)

PARAMETER	SYMBOL	TEST CONDITIONS	$T_A$	$V_+$	MIN	TYP	MAX	UNIT	
<b>Analog Switch</b>									
Analog signal range	$V_{\text{COM}}, V_{\text{NO}}$				0		$V_+$	V	
Peak ON resistance	$r_{\text{peak}}$	$0 \leq V_{\text{NO}} \leq V_+$ , $I_{\text{COM}} = -4\text{ mA}$ , Switch ON, See <a href="#">Figure 13</a>	Full	1.65 V			150	$\Omega$	
ON-state resistance	$r_{\text{on}}$	$V_{\text{NO}} = 0\text{ V}$ , $I_{\text{COM}} = 4\text{ mA}$	25°C	1.65 V		10	20	$\Omega$	
			Full				20		
		25°C	Full				17		50
									50
ON-state resistance match between channels	$\Delta r_{\text{on}}$	$V_{\text{NO}} = 1.15\text{ V}$ , $I_{\text{COM}} = -4\text{ mA}$ , Switch ON, See <a href="#">Figure 13</a>	25°C	1.65 V		0.3		$\Omega$	
ON-state resistance flatness	$r_{\text{on(flat)}}$	$0 \leq V_{\text{NO}} \leq V_+$ , $I_{\text{COM}} = -4\text{ mA}$ , Switch ON, See <a href="#">Figure 13</a>	25°C	1.8 V		140		$\Omega$	
NO OFF leakage current	$I_{\text{NO(OFF)}}$	$V_{\text{NO}} = 0\text{ to }V_+$ , $V_{\text{COM}} = V_+\text{ to }0$ , Switch OFF, See <a href="#">Figure 14</a>	25°C	1.95 V		-0.1	0.1	$\mu\text{A}$	
			Full				-1		1
COM OFF leakage current	$I_{\text{COM(OFF)}}$	$V_{\text{COM}} = 0\text{ to }V_+$ , $V_{\text{NO}} = V_+\text{ to }0$ , Switch OFF, See <a href="#">Figure 14</a>	25°C	1.95 V		-0.1	0.1	$\mu\text{A}$	
			Full				-1		1
NO ON leakage current	$I_{\text{NO(ON)}}$	$V_{\text{NO}} = 0\text{ to }V_+$ , $V_{\text{COM}} = V_+\text{ to }0$ , Switch ON, See <a href="#">Figure 14</a>	25°C	1.95 V		-0.1	0.1	$\mu\text{A}$	
			Full				-1		1
COM ON leakage current	$I_{\text{COM(ON)}}$	$V_{\text{NO}} = \text{Open}$ , $V_{\text{COM}} = 0\text{ to }V_+$ , Switch ON, See <a href="#">Figure 14</a>	25°C	1.95 V		-0.1	0.1	$\mu\text{A}$	
			Full				-1		1
<b>Digital Control Inputs (IN1, IN2)<sup>(2)</sup></b>									
Input logic high	$V_{\text{IH}}$		Full		$V_+ \times 0.75$		5.5	V	
Input logic low	$V_{\text{IL}}$		Full		0		$V_+ \times 0.25$	V	
Input leakage current	$I_{\text{IH}}, I_{\text{IL}}$	$V_I = 5.5\text{ V or }0$	25°C	1.95 V			0.1	$\mu\text{A}$	
			Full				1		

(1) The algebraic convention, whereby the most negative value is a minimum and the most positive value is a maximum

(2) All unused digital inputs of the device must be held at  $V_+$  or GND to ensure proper device operation. Refer to the TI application report, *Implications of Slow or Floating CMOS Inputs*, literature number SCBA004.

**Electrical Characteristics for 1.8-V Supply<sup>(1)</sup> (continued)**
 $V_+ = 1.65\text{ V to }1.95\text{ V}$ ,  $T_A = -40^\circ\text{C to }85^\circ\text{C}$  (unless otherwise noted)

PARAMETER	SYMBOL	TEST CONDITIONS	$T_A$	$V_+$	MIN	TYP	MAX	UNIT
<b>Dynamic</b>								
Turn-on time	$t_{ON}$	$V_{NO} = V_+$ or GND, $R_L = 500\ \Omega$ , $C_L = 50\text{ pF}$ , See <a href="#">Figure 16</a>	25°C	1.8 V	5		32	ns
			Full	1.65 V to 1.95 V	5		34	
Turn-off time	$t_{OFF}$	$V_{NO} = V_+$ or GND, $R_L = 500\ \Omega$ , $C_L = 50\text{ pF}$ , See <a href="#">Figure 16</a>	25°C	1.8 V	3		14	ns
			Full	1.65 V to 1.95 V	3		14.5	
Break-before-make time	$t_{BBM}$	$V_{NO} = V_+$ , $R_L = 50\ \Omega$ , $C_L = 50\text{ pF}$ , See <a href="#">Figure 17</a>	25°C	1.8 V	0.5			ns
			Full	1.65 V to 1.95 V	0.5			
Charge injection	$Q_C$	$V_{GEN} = 0$ , $C_L = 0.1\text{ nF}$ , See <a href="#">Figure 21</a>	25°C	1.8 V		0.3		pC
NO OFF capacitance	$C_{NO(OFF)}$	$V_{NO} = V_+$ or GND, Switch OFF, See <a href="#">Figure 15</a>	25°C	1.8 V		4.5		pF
COM OFF capacitance	$C_{COM(OFF)}$	$V_{NO} = V_+$ or GND, Switch OFF, See <a href="#">Figure 15</a>	25°C	1.8 V		10.5		pF
NO ON capacitance	$C_{NO(ON)}$	$V_{NO} = V_+$ or GND, Switch ON, See <a href="#">Figure 15</a>	25°C	1.8 V		17		pF
COM ON capacitance	$C_{COM(ON)}$	$V_{COM} = V_+$ or GND, Switch ON, See <a href="#">Figure 15</a>	25°C	1.8 V		17		pF
Digital input capacitance	$C_I$	$V_I = V_+$ or GND, See <a href="#">Figure 15</a>	25°C	1.8 V		3		pF
Bandwidth	BW	$R_L = 50\ \Omega$ , Switch ON, See <a href="#">Figure 18</a>	25°C	1.65 V to 1.95 V		341		MHz
OFF isolation	$O_{ISO}$	$R_L = 50\ \Omega$ , $f = 10\text{ MHz}$ , Switch OFF, See <a href="#">Figure 19</a>	25°C	1.65 V to 1.95 V		-81		dB
Crosstalk	$X_{TALK}$	$R_L = 50\ \Omega$ , $f = 10\text{ MHz}$ , Switch ON, See <a href="#">Figure 20</a>	25°C	1.65 V to 1.95 V		-61		dB
<b>Supply</b>								
Positive supply current	$I_+$	$V_I = V_+$ or GND, Switch ON or OFF	25°C	1.95 V			1	$\mu\text{A}$
			Full				10	

### 7.9 Typical Characteristics

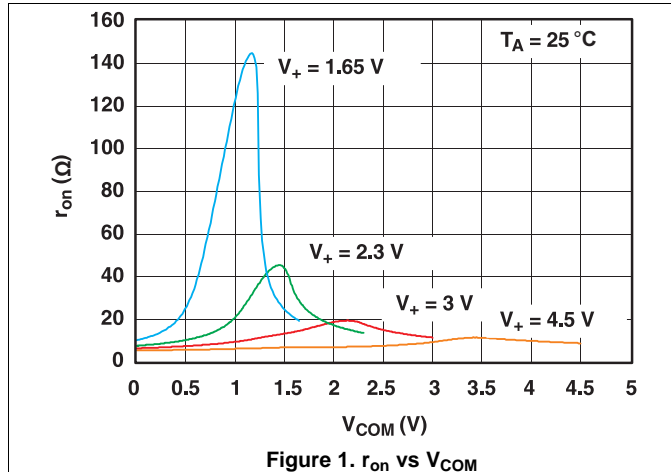

Figure 1.  $r_{on}$  vs  $V_{COM}$

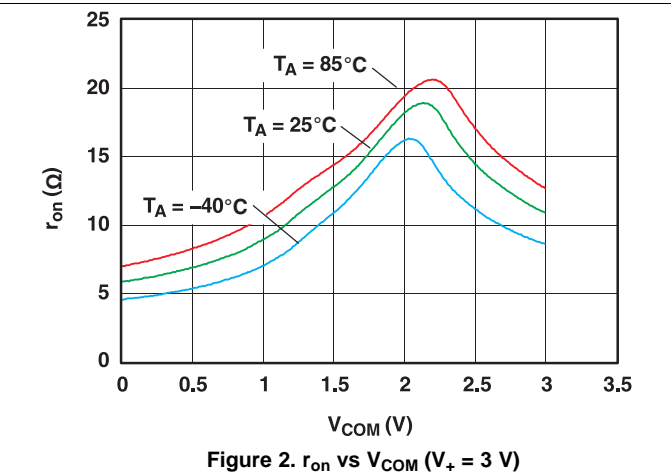

Figure 2.  $r_{on}$  vs  $V_{COM}$  ( $V_+ = 3\text{ V}$ )

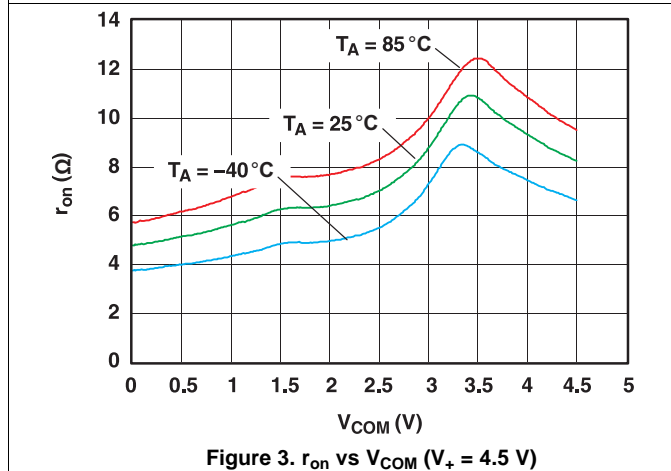

Figure 3.  $r_{on}$  vs  $V_{COM}$  ( $V_+ = 4.5\text{ V}$ )

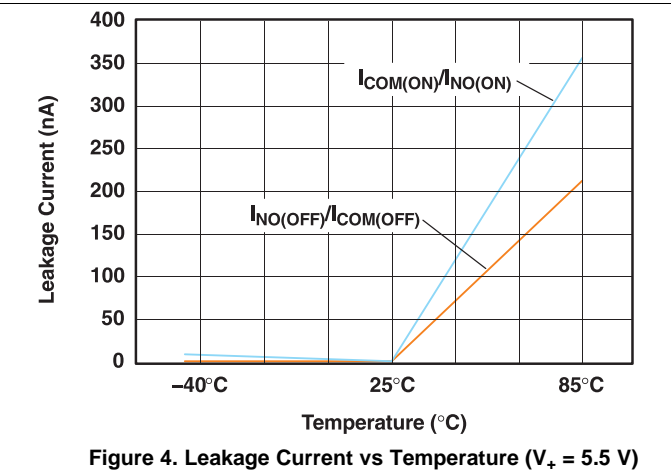

Figure 4. Leakage Current vs Temperature ( $V_+ = 5.5\text{ V}$ )

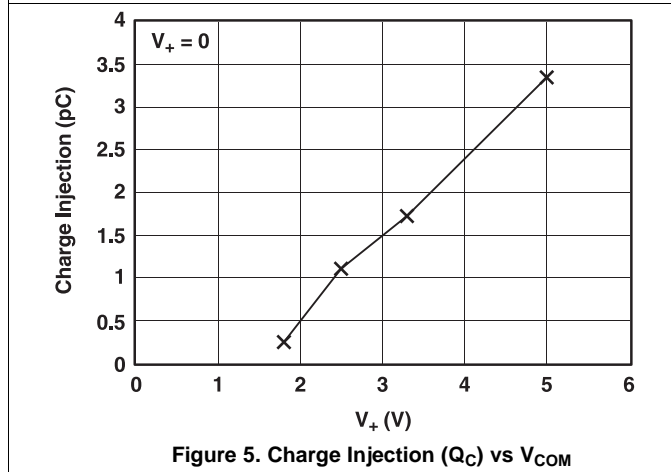

Figure 5. Charge Injection ( $Q_C$ ) vs  $V_{COM}$

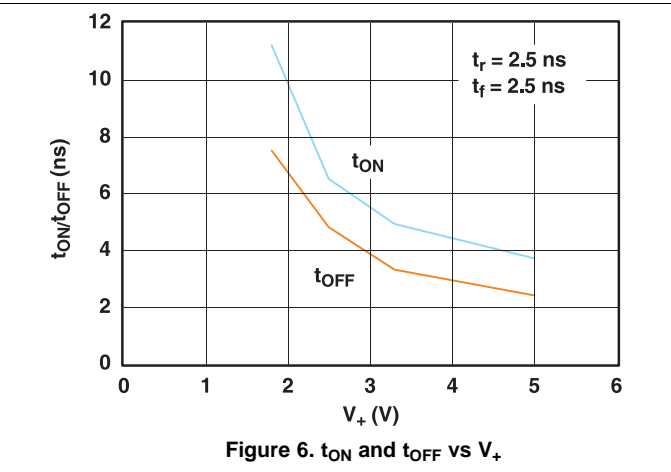

Figure 6.  $t_{ON}$  and  $t_{OFF}$  vs  $V_+$

Typical Characteristics (continued)

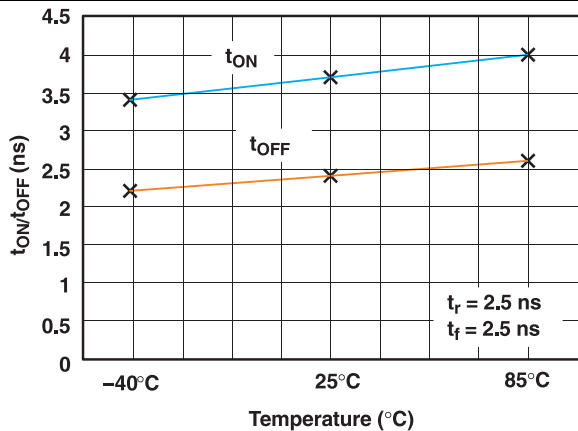

Figure 7. t<sub>ON</sub> and t<sub>OFF</sub> vs Temperature (V<sub>+</sub> = 5 V)

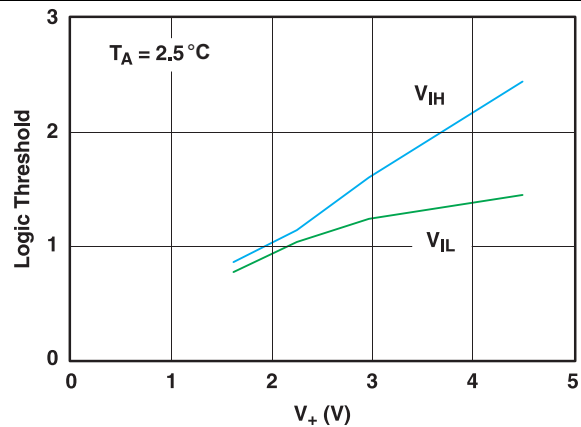

Figure 8. Logic-Level Threshold vs V<sub>+</sub>

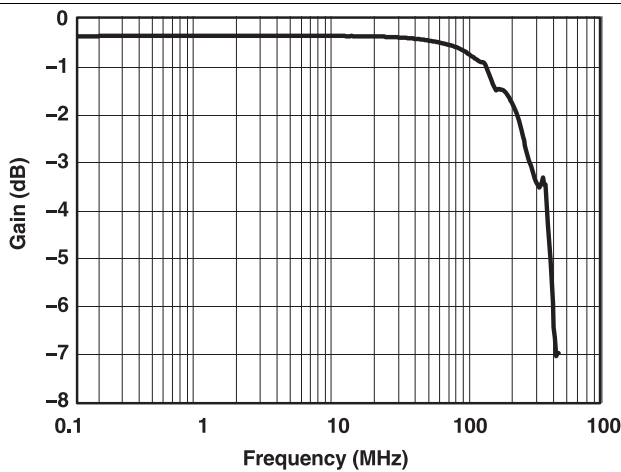

Figure 9. Frequency Response (V<sub>+</sub> = 3 V)

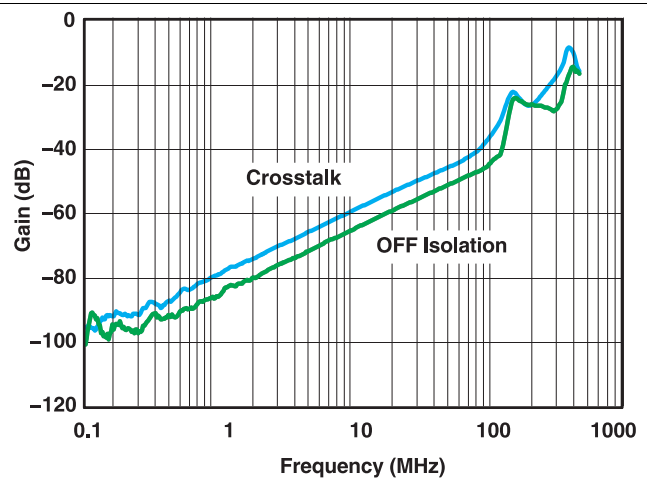

Figure 10. OFF Isolation and Crosstalk vs Frequency (V<sub>+</sub> = 3 V)

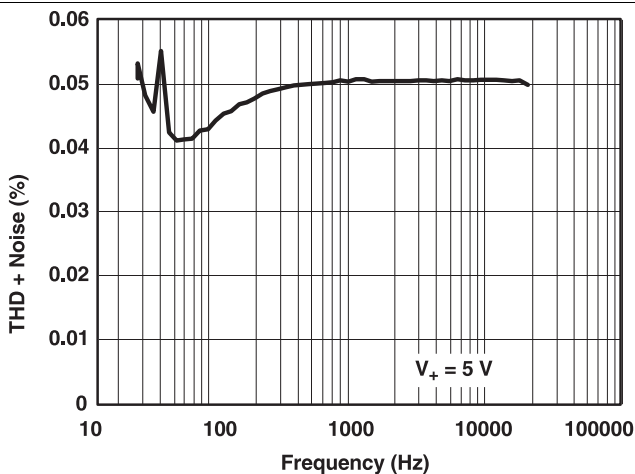

Figure 11. Total Harmonic Distortion vs Frequency (V<sub>+</sub> = 5 V)

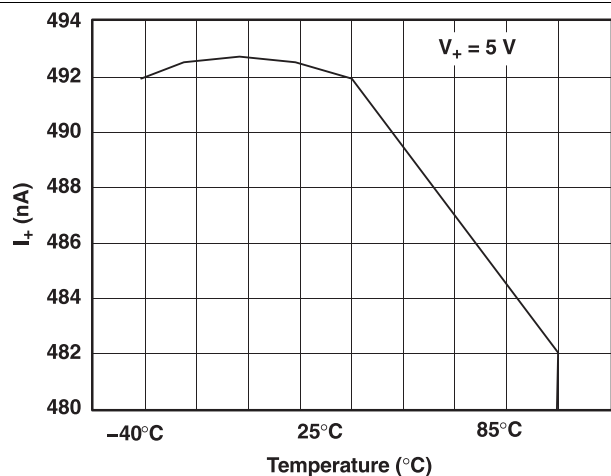

Figure 12. Power-Supply Current vs Temperature (V<sub>+</sub> = 5 V)

## 8 Parameter Measurement Information

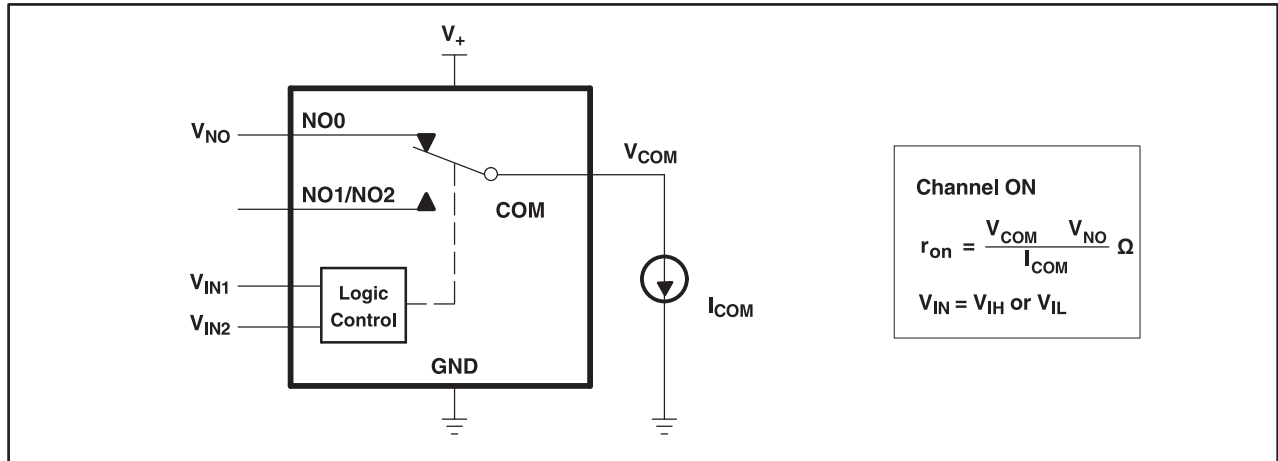

Figure 13. ON-State Resistance ( $r_{on}$ )

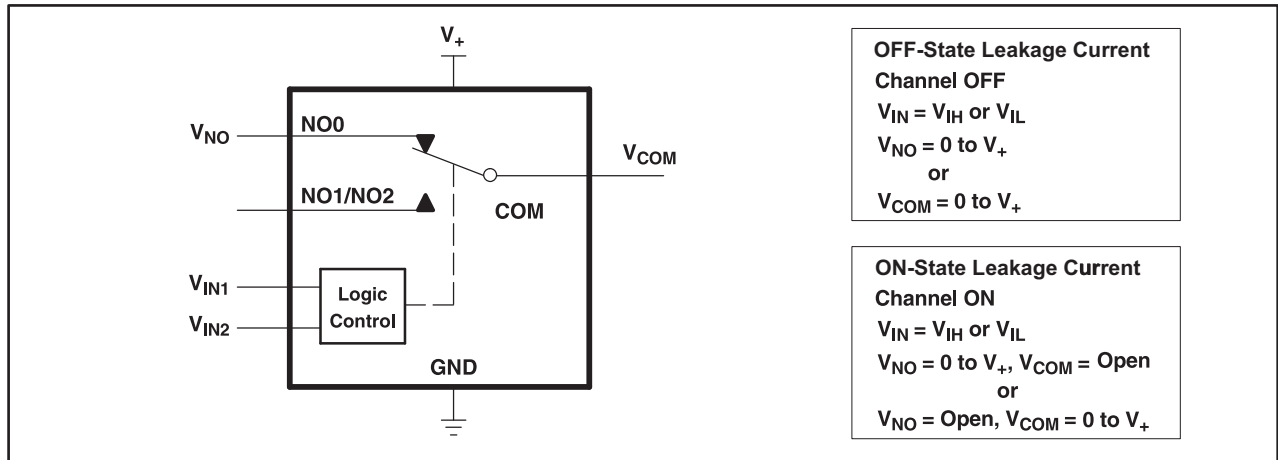

Figure 14. ON- and OFF-State Leakage Current ( $I_{COM(ON)}$ ,  $I_{COM(OFF)}$ ,  $I_{NO(ON)}$ ,  $I_{NO(OFF)}$ )

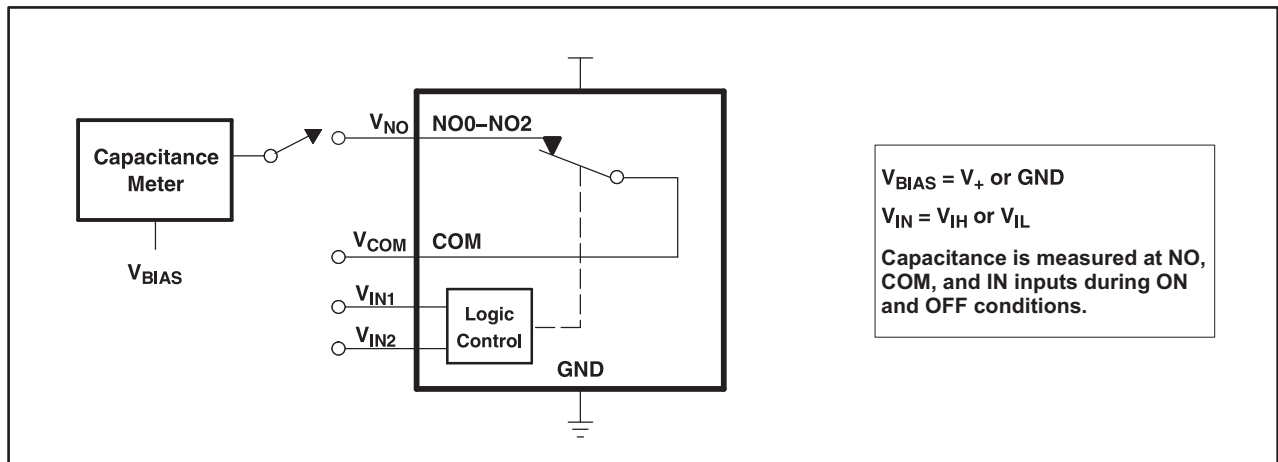
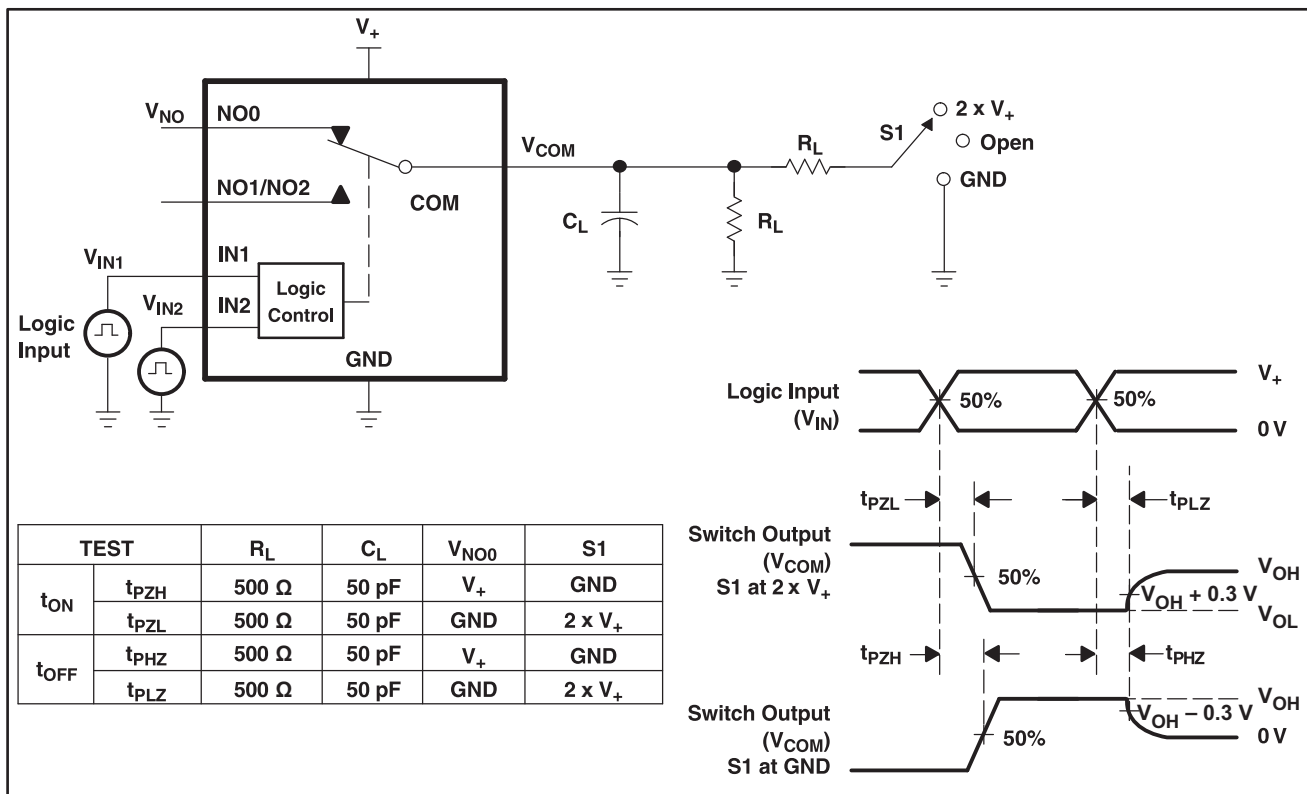

Figure 15. Capacitance ( $C_I$ ,  $C_{COM(ON)}$ ,  $C_{NO(OFF)}$ ,  $C_{COM(OFF)}$ ,  $C_{NO(ON)}$ )

Parameter Measurement Information (continued)



- A. All input pulses are supplied by generators having the following characteristics: PRR  $\leq$  10 MHz,  $Z_O = 50 \Omega$ ,  $t_r < 5$  ns,  $t_f < 5$  ns.
- B.  $C_L$  includes probe and jig capacitance.

Figure 16. Turn-On ( $t_{ON}$ ) and Turn-Off Time ( $t_{OFF}$ )

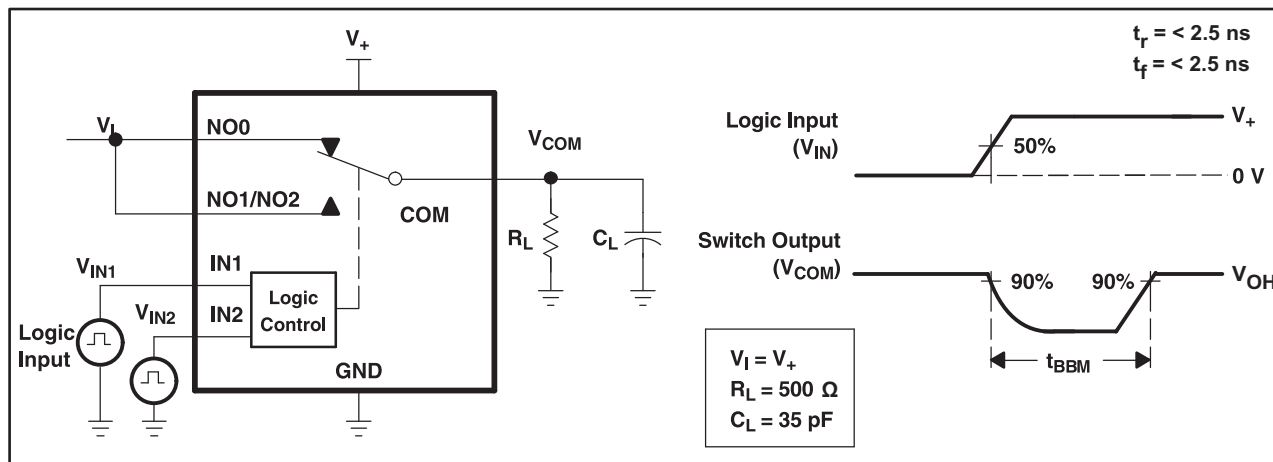

- A. All input pulses are supplied by generators having the following characteristics: PRR  $\leq$  10 MHz,  $Z_O = 50 \Omega$ ,  $t_r < 5$  ns,  $t_f < 5$  ns.
- B.  $C_L$  includes probe and jig capacitance.

Figure 17. Break-Before-Make Time ( $t_{BBM}$ )

Parameter Measurement Information (continued)

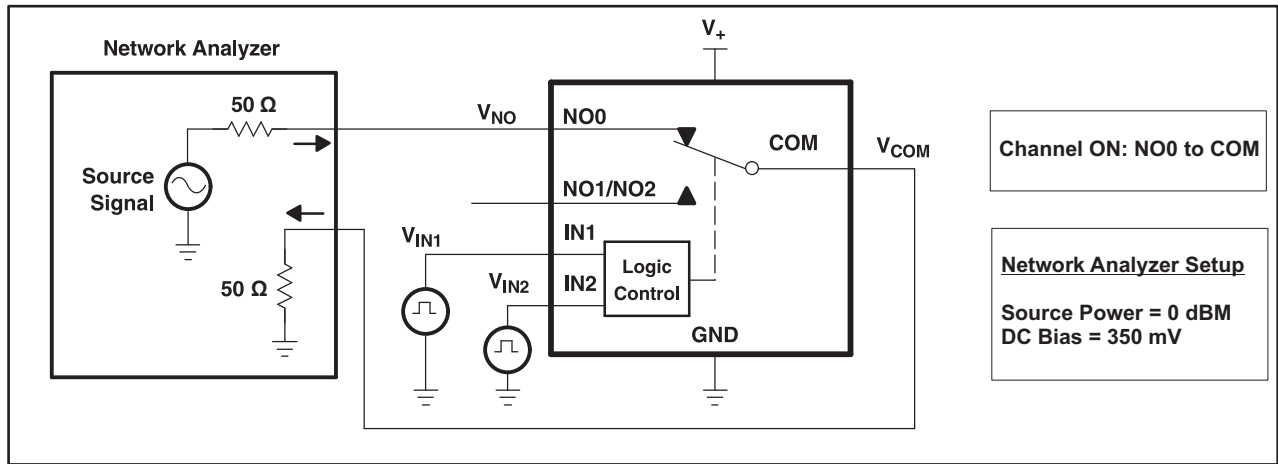

Figure 18. Bandwidth (BW)

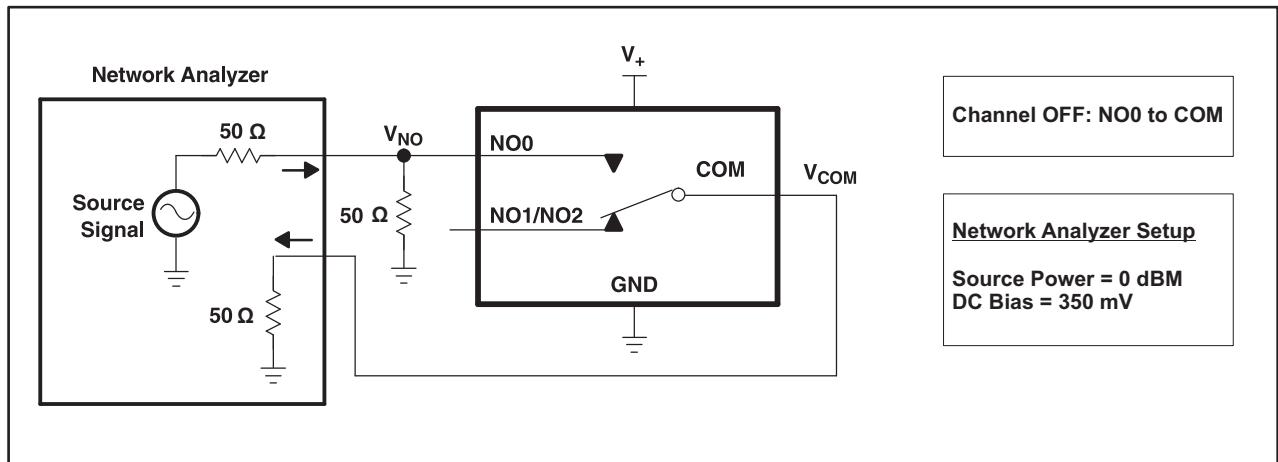

Figure 19. OFF Isolation ( $O_{ISO}$ )

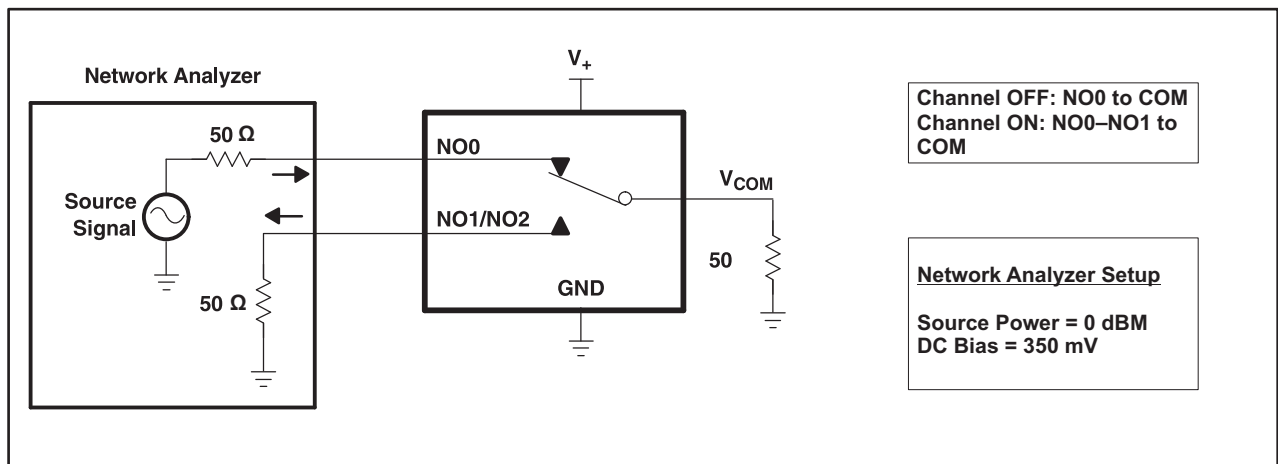
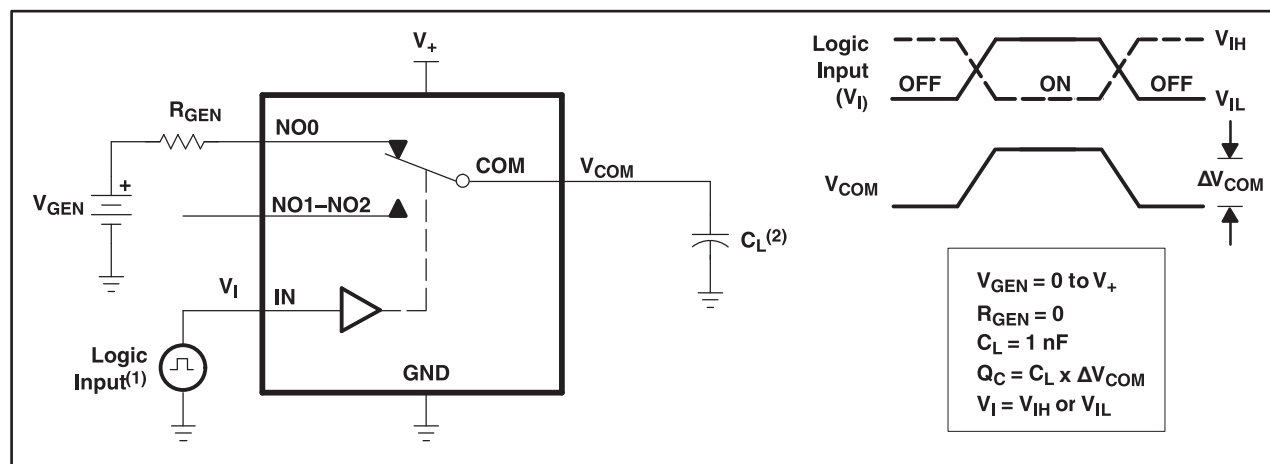

Figure 20. Crosstalk ( $X_{TALK}$ )

Parameter Measurement Information (continued)



- A. All input pulses are supplied by generators having the following characteristics: PRR  $\leq$  10 MHz,  $Z_O = 50 \Omega$ ,  $t_r < 5 \text{ ns}$ ,  $t_f < 5 \text{ ns}$ .
- B.  $C_L$  includes probe and jig capacitance.

Figure 21. Charge Injection ( $Q_C$ )

## 9 Detailed Description

### 9.1 Overview

The TS5A3357 is a bidirectional, single-channel, 3:1 analog switch that is designed to operate from 1.65 V to 5.5 V. This device provides a signal switching solution while maintaining excellent signal integrity, which makes the TS5A3357 suitable for a wide range of applications in various markets including personal electronics, portable instrumentation, and test and measurement equipment. The device maintains the signal integrity by its low ON-state resistance, excellent ON-state resistance matching, and total harmonic distortion (THD) performance. To prevent signal distortion during the transferring of a signal from one channel to another, the TS5A3357 device also has a specified break-before-make feature.

### 9.2 Functional Block Diagram

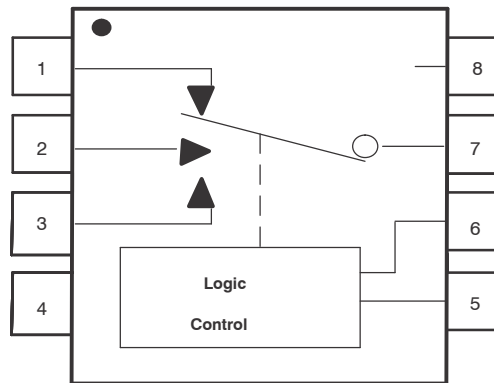

### 9.3 Feature Description

Break-before-make

Break-before-make is a safety feature that prevents two inputs from connecting when the TS5A3357 is switching. The TS5A3357 COM pin first breaks from the on-state switch before making the connection with the next on-state switch. The time delay between the break and the make is known as a break-before-make delay  $t_{BBM}$ .

### 9.4 Device Functional Modes

The digital control pins IN1 and IN2 determine the state of the connection between the COM and NO pins based on the truth table below.

Table 2. Function Table

IN1	IN2	COM TO NO0	COM TO NO1	COM TO NO2
L	L	OFF	OFF	OFF
H	L	ON	OFF	OFF
L	H	OFF	ON	OFF
H	H	OFF	OFF	ON

## 10 Application and Implementation

### NOTE

Information in the following applications sections is not part of the TI component specification, and TI does not warrant its accuracy or completeness. TI's customers are responsible for determining suitability of components for their purposes. Customers should validate and test their design implementation to confirm system functionality.

### 10.1 Application Information

### 10.2 Typical Application

The TS5A3357 switch is bidirectional, so the NO and COM pins can be used as either inputs or outputs. This switch is typically used when there is only one signal path that needs to be able to communicate to 3 different signal paths.

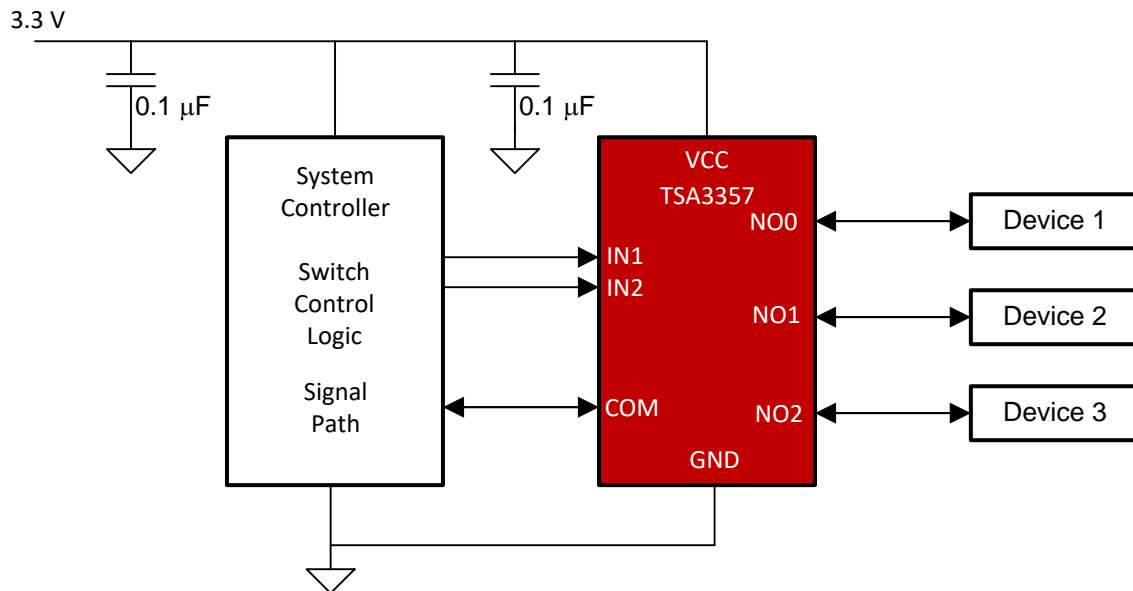

Figure 22. Typical Application Schematic

#### 10.2.1 Design Requirements

The TS5A3357 device can be properly operated without any external components. However, TI recommends connecting unused pins to ground through a 50-Ω resistor to prevent signal reflections back into the device. TI also recommends pulling up the digital control pins (IN1 and IN2) to VCC or pulling down to GND to avoid undesired switch positions that could result from the floating pin.

#### 10.2.2 Detailed Design Procedure

Select the appropriate supply voltage to cover the entire voltage swing of the signal passing through the switch because the TS5A3357 input and output signal swing through NO and COM are dependent on the supply voltage  $V_+$ . For example, if the desired signal level to pass through the switch is 5 V, VCC must be greater than or equal to 5 V.  $V_+ = 3.3$  V would not be valid for passing a 5-V signal since the Analog signal voltage cannot exceed the supply.

## Typical Application (continued)

### 10.2.3 Application Curves

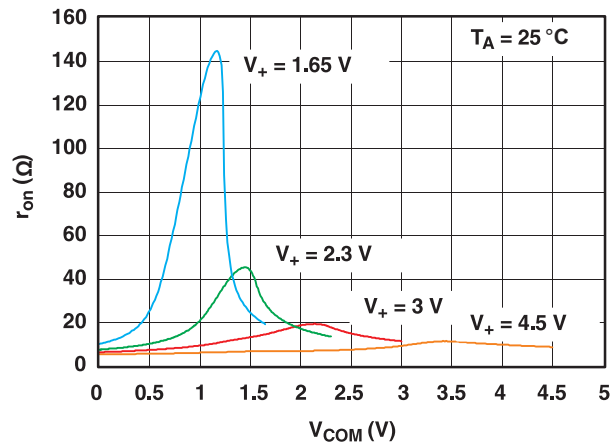

Figure 23.  $r_{on}$  vs  $V_{COM}$

## 11 Power Supply Recommendations

TI recommends proper power-supply sequencing for all CMOS devices. Do not exceed the absolute maximum ratings, because stresses beyond the listed ratings can cause permanent damage to the device. Always sequence  $V_+$  on first, followed by NO or COM. Although it is not required, power-supply bypassing improves noise margin and prevents switching noise propagation from the  $V_+$  supply to other components. A 0.1- $\mu$ F capacitor, connected from VCC to GND, is adequate for most applications.

## 12 Layout

### 12.1 Layout Guidelines

TI recommends following common printed-circuit board layout guidelines to ensure reliability of the device. Bypass capacitors should be used on power supplies. Short trace lengths should be used to avoid excessive loading.

### 12.2 Layout Example

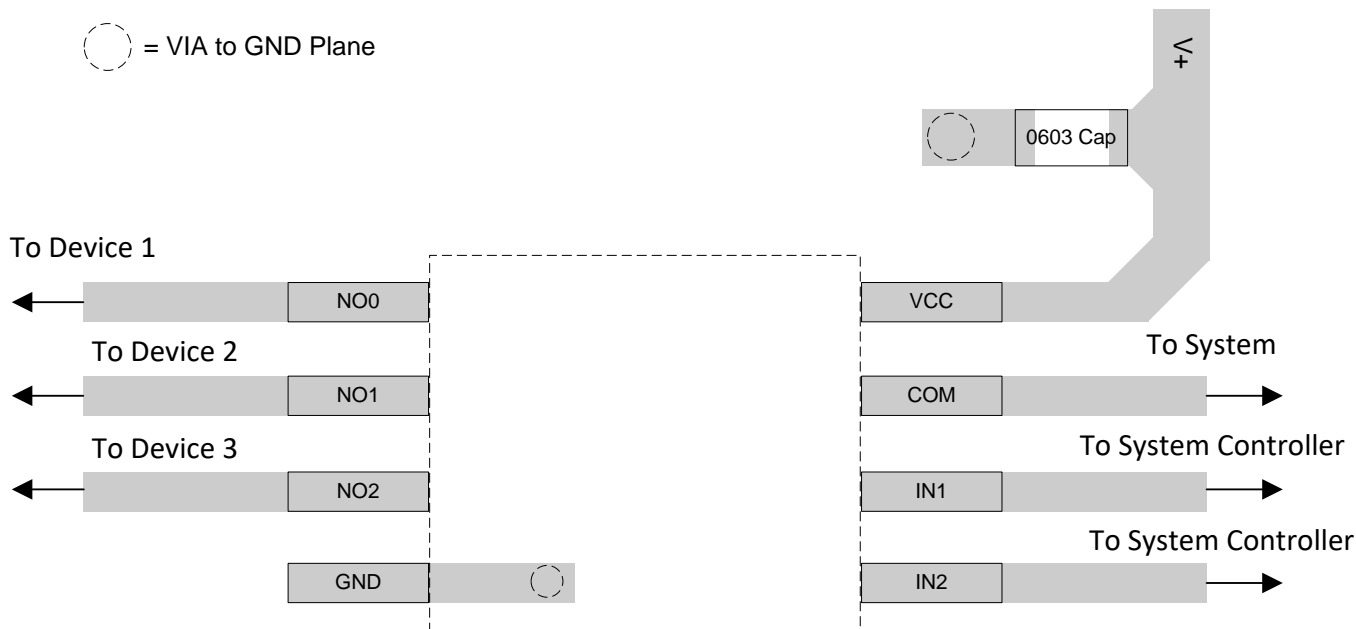

Figure 24. Example Layout

## 13 器件和文档支持

### 13.1 器件支持

### 13.2 文档支持

### 13.3 接收文档更新通知

要接收文档更新通知，请导航至 [TI.com.cn](http://TI.com.cn) 上的器件产品文件夹。单击右上角的 [通知我](#) 进行注册，即可每周接收产品信息更改摘要。有关更改的详细信息，请查看任何已修订文档中包含的修订历史记录。

### 13.4 社区资源

下列链接提供到 TI 社区资源的连接。链接的内容由各个分销商“按照原样”提供。这些内容并不构成 TI 技术规范，并且不一定反映 TI 的观点；请参阅 TI 的 [《使用条款》](#)。

**TI E2E™ 在线社区** [TI 的工程师对工程师 \(E2E\) 社区](#)。此社区的创建目的在于促进工程师之间的协作。在 [e2e.ti.com](http://e2e.ti.com) 中，您可以咨询问题、分享知识、拓展思路并与同行工程师一道帮助解决问题。

**设计支持** [TI 参考设计支持](#) 可帮助您快速查找有帮助的 E2E 论坛、设计支持工具以及技术支持的联系信息。

### 13.5 商标

E2E is a trademark of Texas Instruments.

### 13.6 静电放电警告



ESD 可能会损坏该集成电路。德州仪器 (TI) 建议通过适当的预防措施处理所有集成电路。如果不遵守正确的处理措施和安装程序，可能会损坏集成电路。

ESD 的损坏小至导致微小的性能降级，大至整个器件故障。精密的集成电路可能更容易受到损坏，这是因为非常细微的参数更改都可能会导致器件与其发布的规格不相符。

### 13.7 术语表

[SLYZ022](#) — *TI 术语表*。

这份术语表列出并解释术语、缩写和定义。

## 14 机械、封装和可订购信息

以下页面包含机械、封装和可订购信息。这些信息是指定器件的最新可用数据。数据如有变更，恕不另行通知，且不会对此文档进行修订。如需获取此产品说明书的浏览器版本，请查阅左侧的导航栏。

**PACKAGING INFORMATION**

Orderable part number	Status (1)	Material type (2)	Package   Pins	Package qty   Carrier	RoHS (3)	Lead finish/ Ball material (4)	MSL rating/ Peak reflow (5)	Op temp (°C)	Part marking (6)
<a href="#">TS5A3357DCUR</a>	Active	Production	VSSOP (DCU)   8	3000   LARGE T&R	Yes	NIPDAU   SN	Level-1-260C-UNLIM	-40 to 85	(JA9Q, JA9R)
TS5A3357DCUR.B	Active	Production	VSSOP (DCU)   8	3000   LARGE T&R	Yes	SN	Level-1-260C-UNLIM	-40 to 85	(JA9Q, JA9R)
<a href="#">TS5A3357DCURG4</a>	Active	Production	VSSOP (DCU)   8	3000   LARGE T&R	Yes	NIPDAU	Level-1-260C-UNLIM	-40 to 85	JA9R
TS5A3357DCURG4.B	Active	Production	VSSOP (DCU)   8	3000   LARGE T&R	Yes	NIPDAU	Level-1-260C-UNLIM	-40 to 85	JA9R

(1) **Status:** For more details on status, see our [product life cycle](#).

(2) **Material type:** When designated, preproduction parts are prototypes/experimental devices, and are not yet approved or released for full production. Testing and final process, including without limitation quality assurance, reliability performance testing, and/or process qualification, may not yet be complete, and this item is subject to further changes or possible discontinuation. If available for ordering, purchases will be subject to an additional waiver at checkout, and are intended for early internal evaluation purposes only. These items are sold without warranties of any kind.

(3) **RoHS values:** Yes, No, RoHS Exempt. See the [TI RoHS Statement](#) for additional information and value definition.

(4) **Lead finish/Ball material:** Parts may have multiple material finish options. Finish options are separated by a vertical ruled line. Lead finish/Ball material values may wrap to two lines if the finish value exceeds the maximum column width.

(5) **MSL rating/Peak reflow:** The moisture sensitivity level ratings and peak solder (reflow) temperatures. In the event that a part has multiple moisture sensitivity ratings, only the lowest level per JEDEC standards is shown. Refer to the shipping label for the actual reflow temperature that will be used to mount the part to the printed circuit board.

(6) **Part marking:** There may be an additional marking, which relates to the logo, the lot trace code information, or the environmental category of the part.

Multiple part markings will be inside parentheses. Only one part marking contained in parentheses and separated by a "~" will appear on a part. If a line is indented then it is a continuation of the previous line and the two combined represent the entire part marking for that device.

**Important Information and Disclaimer:** The information provided on this page represents TI's knowledge and belief as of the date that it is provided. TI bases its knowledge and belief on information provided by third parties, and makes no representation or warranty as to the accuracy of such information. Efforts are underway to better integrate information from third parties. TI has taken and continues to take reasonable steps to provide representative and accurate information but may not have conducted destructive testing or chemical analysis on incoming materials and chemicals. TI and TI suppliers consider certain information to be proprietary, and thus CAS numbers and other limited information may not be available for release.

In no event shall TI's liability arising out of such information exceed the total purchase price of the TI part(s) at issue in this document sold by TI to Customer on an annual basis.

**OTHER QUALIFIED VERSIONS OF TS5A3357 :**

- Automotive : [TS5A3357-Q1](#)

NOTE: Qualified Version Definitions:

- Automotive - Q100 devices qualified for high-reliability automotive applications targeting zero defects

**TAPE AND REEL INFORMATION**

**QUADRANT ASSIGNMENTS FOR PIN 1 ORIENTATION IN TAPE**



\*All dimensions are nominal

Device	Package Type	Package Drawing	Pins	SPQ	Reel Diameter (mm)	Reel Width W1 (mm)	A0 (mm)	B0 (mm)	K0 (mm)	P1 (mm)	W (mm)	Pin1 Quadrant
TS5A3357DCUR	VSSOP	DCU	8	3000	178.0	9.0	2.25	3.35	1.05	4.0	8.0	Q3
TS5A3357DCURG4	VSSOP	DCU	8	3000	180.0	8.4	2.25	3.35	1.05	4.0	8.0	Q3

**TAPE AND REEL BOX DIMENSIONS**

\*All dimensions are nominal

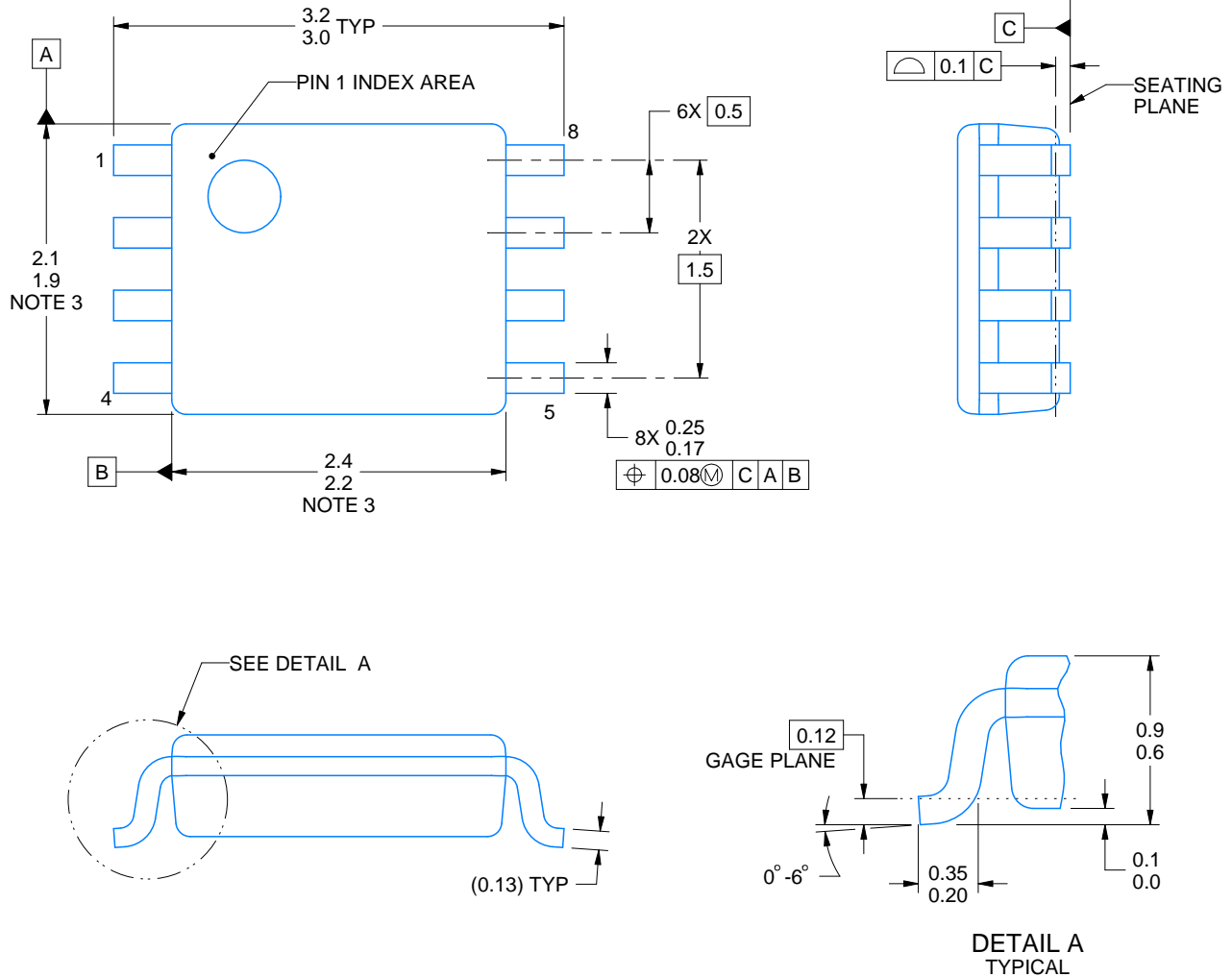
Device	Package Type	Package Drawing	Pins	SPQ	Length (mm)	Width (mm)	Height (mm)
TS5A3357DCUR	VSSOP	DCU	8	3000	180.0	180.0	18.0
TS5A3357DCURG4	VSSOP	DCU	8	3000	202.0	201.0	28.0



4225266/A 09/2014

NOTES:

1. All linear dimensions are in millimeters. Any dimensions in parenthesis are for reference only. Dimensioning and tolerancing per ASME Y14.5M.
2. This drawing is subject to change without notice.
3. This dimension does not include mold flash, protrusions, or gate burrs. Mold flash, protrusions, or gate burrs shall not exceed 0.15 mm per side.
4. Reference JEDEC registration MO-187 variation CA.

# EXAMPLE BOARD LAYOUT

DCU0008A

VSSOP - 0.9 mm max height

SMALL OUTLINE PACKAGE

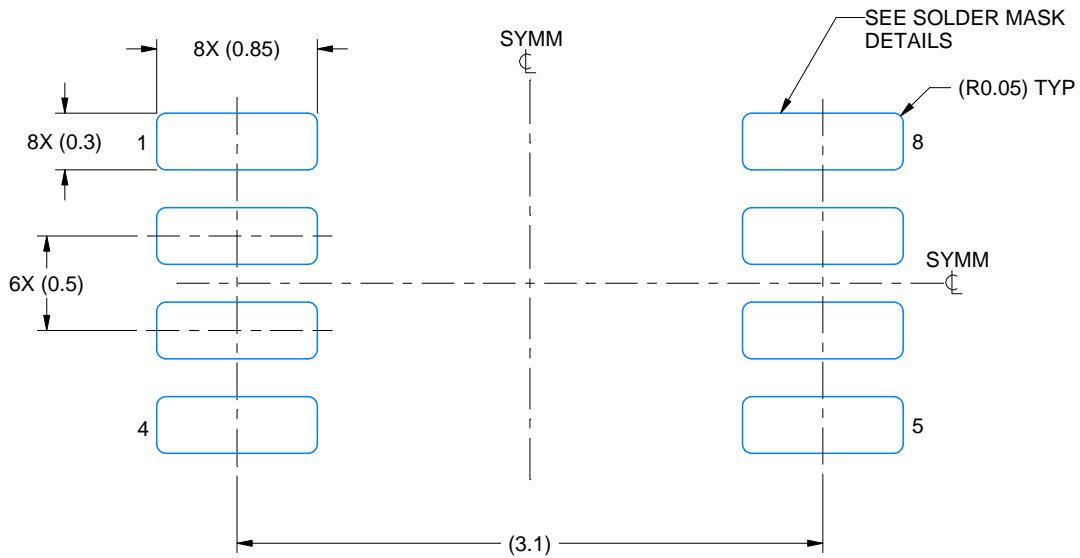

LAND PATTERN EXAMPLE  
EXPOSED METAL SHOWN  
SCALE: 25X



4225266/A 09/2014

NOTES: (continued)

- 5. Publication IPC-7351 may have alternate designs.
- 6. Solder mask tolerances between and around signal pads can vary based on board fabrication site.

# EXAMPLE STENCIL DESIGN

DCU0008A

VSSOP - 0.9 mm max height

SMALL OUTLINE PACKAGE



SOLDER PASTE EXAMPLE  
BASED ON 0.125 mm THICK STENCIL  
SCALE: 25X

4225266/A 09/2014

NOTES: (continued)

7. Laser cutting apertures with trapezoidal walls and rounded corners may offer better paste release. IPC-7525 may have alternate design recommendations.
8. Board assembly site may have different recommendations for stencil design.

## 重要通知和免责声明

TI“按原样”提供技术和可靠性数据（包括数据表）、设计资源（包括参考设计）、应用或其他设计建议、网络工具、安全信息和其他资源，不保证没有瑕疵且不做任何明示或暗示的担保，包括但不限于对适销性、与某特定用途的适用性或不侵犯任何第三方知识产权的暗示担保。

这些资源可供使用 TI 产品进行设计的熟练开发人员使用。您将自行承担以下全部责任：(1) 针对您的应用选择合适的 TI 产品，(2) 设计、验证并测试您的应用，(3) 确保您的应用满足相应标准以及任何其他安全、安保法规或其他要求。

这些资源如有变更，恕不另行通知。TI 授权您仅可将这些资源用于研发本资源所述的 TI 产品的相关应用。严禁以其他方式对这些资源进行复制或展示。您无权使用任何其他 TI 知识产权或任何第三方知识产权。对于因您对这些资源的使用而对 TI 及其代表造成的任何索赔、损害、成本、损失和债务，您将全额赔偿，TI 对此概不负责。

TI 提供的产品受 [TI 销售条款](#)、[TI 通用质量指南](#) 或 [ti.com](#) 上其他适用条款或 TI 产品随附的其他适用条款的约束。TI 提供这些资源并不会扩展或以其他方式更改 TI 针对 TI 产品发布的适用的担保或担保免责声明。除非德州仪器 (TI) 明确将某产品指定为定制产品或客户特定产品，否则其产品均为按确定价格收入目录的标准通用器件。

TI 反对并拒绝您可能提出的任何其他或不同的条款。

版权所有 © 2026，德州仪器 (TI) 公司

最后更新日期：2025 年 10 月