LOW-POWER BATTERY BACKUP IC WITH INTEGRATED BOOST CONVERTER

FEATURES

- Power-Path Switch to Select Main Battery or Backup Battery for Real-Time Clock (RTC)
- Integrated Boost DC/DC Converter
 - Modulation Select by Control Pin (PWMON), Pulse Frequency Modulation (PFM) or Pulse Width Modulation (PWM)
 - Fixed Switching Frequency (PWM, 750 kHz)
 - Peak Current Mode Control (PWM)
 - Low Power Consumption (PFM)
- Four Integrated Low Dropout (LDO) Voltage Regulators for 1.2 V/1.8 V/3.3 V
- Two Integrated Indicators
 - CS: Monitors the Voltage Level of Main Battery (VBAT) and Output voltage level of Boost Converter (VO_BT)
 - XRESET: Monitors the Output voltage Level of 3.3V LDO (VOUT)
- 16-Pin QFN (3mm × 3mm) Package
- Operating Temperature –35°C to 85°C
- Protection
 - Overcurrent Protection (OCP)
 - Overvoltage Protection (OVP)
 - Thermal Shutdown (TSD)
 - Undervoltage Lockout (UVLO)

APPLICATIONS

- Digital Still Cameras
- Portable Systems With Backup Battery

DESCRIPTION

The TPS65510 offers a suitable solution for power switch to select the main battery or the backup battery.

This device automatically selects the power path. It depends on the voltage level of the VO_BT pin. When the main battery is removed, the power path of the VOUT pin is automatically changed from the output of 3.3-V low dropout (LDO) voltage regulator to the backup battery.

The backup battery is charged from the power path of the VRO pin (output of 3.3-V LDO) via an external diode and resistor. The input of the LDO voltage regulator comes from the internal boost converter.

The 1.2-V output LDO and 1.8-V output LDO voltage regulators have a enable pin, V_CTRL. If these outputs are not necessary, V_CTRL should be connected to AGND to save power consumption. The self-power consumption is less than 3 µA (maximum) using the backup battery.

This device has two indicators. One is CS, which monitors the voltage level of the VBAT pin and VO_BT pin. The other is XRESET, which monitors voltage level of the VOUT pin. These indicators should be connected to CPU/DSP to reset them.

This device reduces the total solution area and extends the lifetime of the backup battery.



Please be aware that an important notice concerning availability, standard warranty, and use in critical applications of Texas Instruments semiconductor products and disclaimers thereto appears at the end of this data sheet.

PowerPAD is a trademark of Texas Instruments.



These devices have limited built-in ESD protection. The leads should be shorted together or the device placed in conductive foam during storage or handling to prevent electrostatic damage to the MOS gates.

APPLICATION CIRCUIT

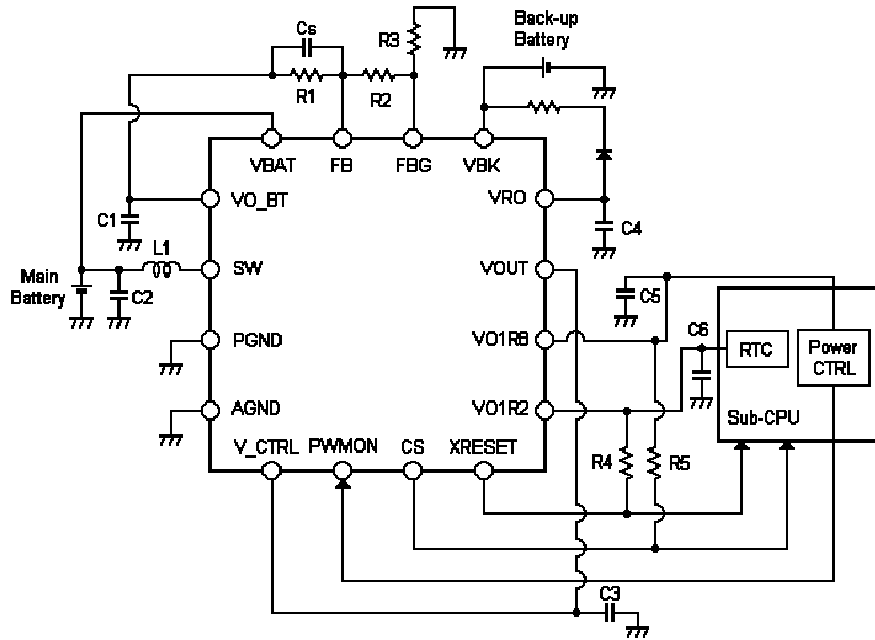

Figure 1. Typical Application Circuit (1.2-V/1.8-V Output)

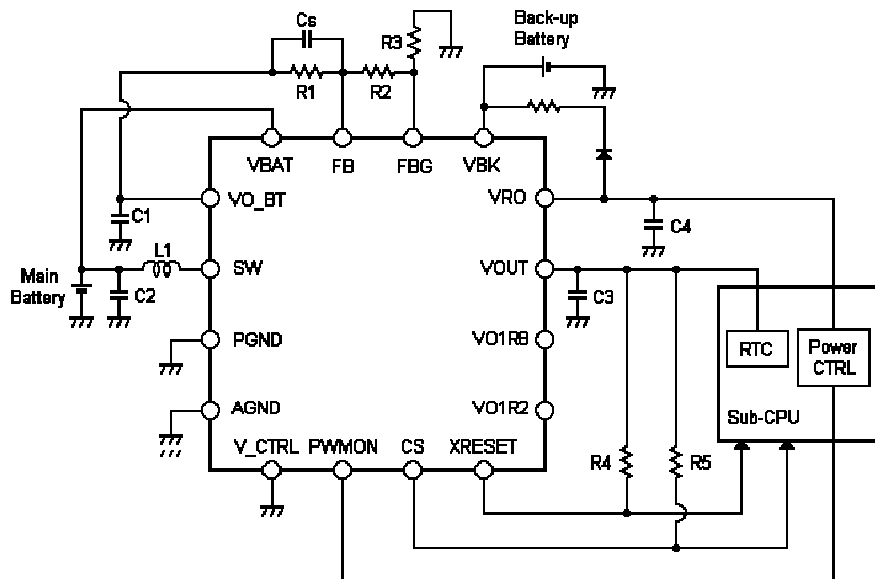

Figure 2. Typical Application Circuit (3.3-V Output)

ORDERING INFORMATION

T _A	PACKAGE MARKING	PACKAGE	PART NUMBER
–35°C to 85°C	CGK	16-pin QFN	TPS65510RGT

ABSOLUTE MAXIMUM RATINGS⁽¹⁾

over operating free-air temperature range (unless otherwise noted)

		MIN	MAX	UNIT
V _{BAT} , V _{BK}	Input voltage range	–0.3	6	V
SW		–0.3	7	
F _B , F _{BG}		–0.3	6	
P _{WMON} , V _{CTRL}		–0.3	6	
X _{RESET} , CS	Output voltage range	–0.3	6	V
V _{RO} , V _{OUT} , V _{O1R8} , V _{O1R2}		–0.3	3.6	
V _{O_BT}		–0.3	6	
SW	Switch current		1.3	A
Maximum junction temperature range			125	°C
Storage temperature range		–40	150	°C

(1) Stresses beyond those listed under "absolute maximum ratings" may cause permanent damage to the device. These are stress ratings only and functional operation of the device at these or any other conditions beyond those indicated under "recommended operating conditions" is not implied. Exposure to absolute-maximum-rated conditions for extended periods may affect device reliability.

DISSIPATION RATINGS

PACKAGE	R _{θJA} ⁽¹⁾	POWER RATING T _A < 25°C	POWER RATING T _A = 85°C
QFN	47.4°C/W	2.11 W	0.844 W

(1) The thermal resistance, R_{θJA}, is based on a soldered PowerPAD™ on 2S2P JEDEC board using thermal vias.

RECOMMENDED OPERATING CONDITIONS

over operating free-air temperature range (unless otherwise noted)

		MIN	TYP	MAX	UNIT
V _{BAT}	Supply voltage	2.65		5.5	V
V _{BK}		1.8		5.5	
V _{IH}	High-level digital input voltage at P _{WMON}	1.4		5.5	V
	High-level digital input voltage at V _{CTRL}	1.4		V _{OUT}	
V _{IL}	Low-level digital input voltage at P _{WMON}			0.4	V
	Low-level digital input voltage at V _{CTRL}			0.4	
Operating free-air temperature range		–35		85	°C

ELECTRICAL CHARACTERISTICS

T_A = 25°C (unless otherwise noted)

PARAMETER		TEST CONDITIONS	MIN	TYP	MAX	UNIT
I _{CC1}	Consumption current at VO_BT	V _(VO_BT) : 3.6 V, VOUT: No load V _(PWMON) : AGND (PFM mode)		60	100	μA
I _{CC2}	Consumption current at VO_BT	V _(VO_BT) : 5 V, VOUT: No load V _(PWMON) : VOUT (PWM mode)		250	350	μA
I _{CC3}	Consumption current at VBK	V _(VO_BT) : 3.6 V, V _(VBK) : 3 V VOUT: No load		0.1	1	μA
I _{CC4}	Consumption current at VBK	VO_BT: Open, V _(VBK) : 3 V VOUT: No load, V _(V_CTRL) : VOUT		2.5	5	μA
I _{CC5}	Consumption current at VBK	VO_BT: Open, V _(VBK) : 3 V VOUT: No load, V _(V_CTRL) : AGND		1.2	3	μA
I _{CC6}	Consumption current at VBAT	V _(VBAT) : 3.6 V, V _(VO_BT) : 3.5 V		5	10	μA
I _(SINK_CS)	Sink current at CS	V _(CS) : 0.5 V, CS pin: Low-Z	1	1.5		mA
I _(LEAK_CS)	Leakage current at CS	V _(CS) : 5.5 V, CS pin: Hi-Z			1	μA
I _(SINK_XRESET)	Sink current at XRESET	V _(XRESET) : 0.5 V, XRESET pin: Low-Z	1	1.5		mA
I _(LEAK_XRESET)	Leak current at XRESET	V _(XRESET) : 5.5 V, XRESET pin: Hi-Z			1	μA
I _(LEAK_VBK)	Leak current at VBK	V _(VO_BT) : 5.5 V, V _(VBK) : 0 V			1	μA
V _(UVLO_DET)	UVLO/CS detection level at VBAT	V _(VBAT) : from 0 V to 5.5 V	2.50	2.70	2.90	V
V _(UVLO_HYS)	UVLO/CS hysteresis at VBAT	V _(VBAT) : from 5.5 V to 0 V	–250	–200	–150	mV
V _(CS_DET)	CS detection level at VO_BT	V _(VO_BT) : from 5 V to 0 V	3.071	3.150	3.229	V
V _(CS_HYS)	CS hysteresis at VO_BT	V _(VO_BT) : from 0 V to 5 V	50	100	150	mV
V _(XRESET_DET)	XRESET detection level	V _(VOUT) : from 3.3 V to 0 V	2.048	2.100	2.153	V
V _(XRESET_HYS)	XRESET hysteresis	V _(VOUT) : from 0 V to 3.3 V	50	100	150	mV
V _(SW1)	Change the power path for VOUT	Monitoring at VO_BT	2.94	3.00	3.06	V
V _(SW2)	CS output disable level	Monitoring at VOUT	3.072	3.135	3.198	V
V _(WAKE_DET)	Threshold of WAKE mode	V _(VO_BT) : from 0 V to 3.6 V	2.38	2.50	2.63	V
V _(WAKE_HYS)	WAKE mode hysteresis	V _(VO_BT) : from 3.6 V to 0 V	–150	–100	–50	mV
R _(ON_VBK)	On resistance between VBK and VOUT	VO_BT: Open, V _(VBK) : 3 V, I _(VOUT) : 2 mA		30	60	Ω
TSD ⁽¹⁾	Thermal shutdown detection temperature			150		°C

(1) Specified by design. Not production tested.

ELECTRICAL CHARACTERISTICS (continued)
 $T_A = 25^\circ\text{C}$ (unless otherwise noted)

PARAMETER		TEST CONDITIONS	MIN	TYP	MAX	UNIT
Boost DC/DC Converter						
$V_{(FB)}$	Reference voltage	$V_{(PWMON)}$: AGND (PFM mode)	1.213	1.250	1.288	V
		$V_{(PWMON)}$: VOUT (PWM mode)	1.225	1.250	1.275	
	Overvoltage protection threshold	Monitoring at FB	1.30	1.35	1.40	V
	Overcurrent protection threshold	$V_{(PWMON)}$: AGND (PFM mode)	0.48	0.60	0.72	A
		$V_{(PWMON)}$: VOUT (PWM mode)	0.8	1.0	1.2	
OSC	Internal OSC frequency	$V_{(PWMON)}$: VOUT (PWM mode)	675	750	825	kHz
$R_{(ON_P)}$	P-ch FET ON resistance	$V_{(VO_BT)}$: 5 V		500	700	m Ω
$R_{(ON_N)}$	N-ch FET ON resistance	$V_{(VO_BT)}$: 5 V		200	250	m Ω
$R_{(ON_FBG)}$	FBG ON resistance	$V_{(PWMON)}$: VOUT (PWM mode)		1	1.5	k Ω
$I_{(LEAK_FBG)}$	Leakage current at FBG	$V_{(PWMON)}$: AGND (PFM mode)			1	μA
3.3-V Output LDO (VOUT)						
$V_{(VOUT)}$	Output voltage of VOUT	$V_{(VO_BT)}$: 5 V, $I_{(VOUT)}$: 1 mA	3.234	3.300	3.366	V
$I_{(VOUT)}$	Output current of VOUT	$V_{(VO_BT)}$: 5 V, $V_{(VOUT)} \geq 3.156$ V			30	mA
	Overcurrent protection threshold			50		mA
3.3-V Output LDO (VRO)						
$V_{(VRO)}$	Output voltage of VRO	$V_{(VO_BT)}$: 5 V, $I_{(VRO)}$: 1 mA	3.234	3.300	3.366	V
$I_{(VRO)}$	Output current of VRO	$V_{(VO_BT)}$: 5 V, $V_{(VRO)} \geq 3.156$ V		10	30	mA
	Overcurrent protection threshold			50		mA
1.8-V Output LDO (VO1R8)						
$V_{(VO1R8)}$	Output voltage of VO1R8	$V_{(V_CTRL)}$: VOUT, $V_{(VO_BT)}$: 5 V, $I_{(VO1R8)}$: 100 μA	1.71	1.80	1.89	V
$I_{(VO1R8)}$	Output current of VO1R8	$V_{(V_CTRL)}$: VOUT			100	μA
1.2-V Output LDO (VO1R2)						
$V_{(VO1R2)}$	Output voltage of VO1R2	$V_{(V_CTRL)}$: VOUT, $V_{(VO_BT)}$: 5 V, $I_{(VO1R2)}$: 100 μA	1.1	1.2	1.3	V
$I_{(VO1R2)}$	Output current of VO1R2	$V_{(V_CTRL)}$: VOUT			100	μA

SWITCHING CHARACTERISTICS
 $T_A = 25^\circ\text{C}$ (unless otherwise noted)

PARAMETER		TEST CONDITIONS	MIN	TYP	MAX	UNIT
$T_{CS}^{(1)}$	Detection delay at CS	$V_{(VO_BT)}$: from 3.6 V to 2.0 V		55		μs
$T_{XRESET}^{(1)}$	Detection delay at XRESET	$V_{(VOUT)}$: from 1.5 V to 3.0 V		25		μs

(1) Specified by design. Not production tested.

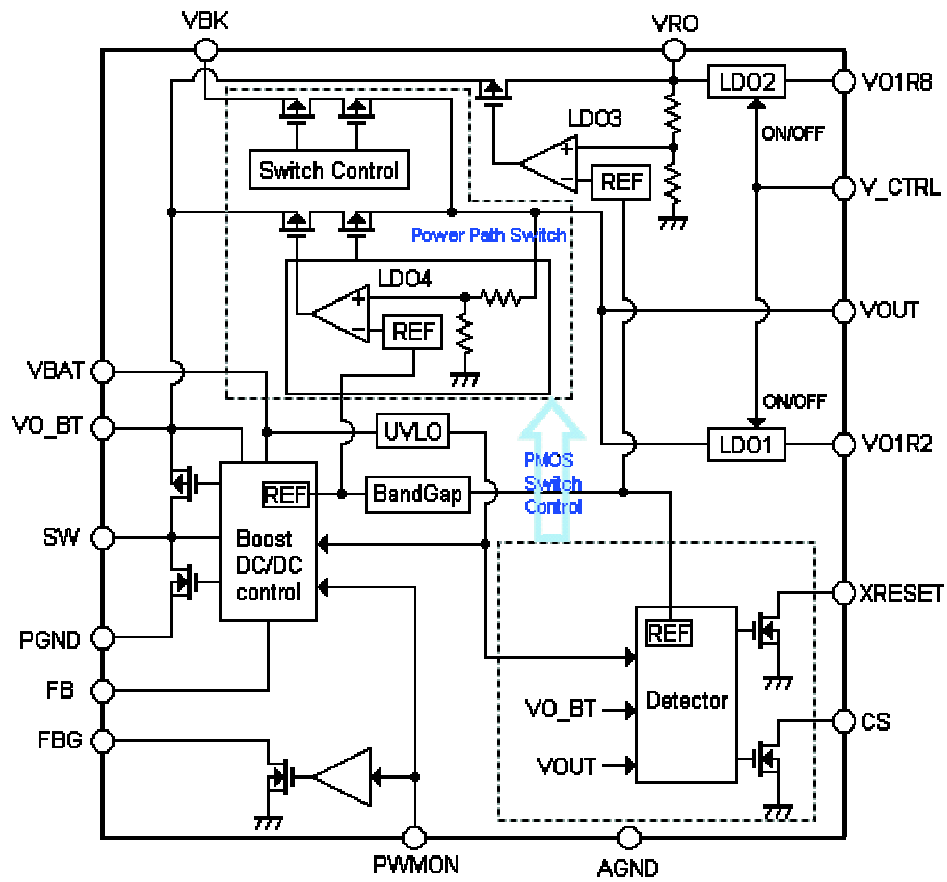
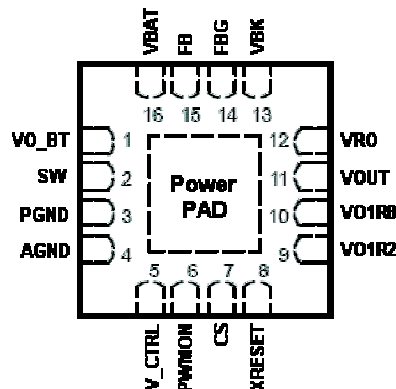

Figure 3. Block Diagram

PIN ASSIGNMENTS

TERMINAL FUNCTIONS

TERMINAL		I/O ⁽¹⁾	DESCRIPTION
NO.	NAME		
1	VO_BT	O	Boost converter output. This voltage is defined by the ration of external resistors. Please see the description in detail.
2	SW	I	Switching terminal for boost converter. This terminal should be connected to the external inductor.
3	PGND	G	Power ground. Connect to the ground plane.
4	AGND	G	Analog ground. Connect to the ground lane.
5	V_CTRL	I	LDO Enable/Disable input. When the input level is Low, it disables the operation of LDOs regarding VO1R8 and VO1R2. When the input level is high, it enables the operation of LDOs regarding VO1R8 and VO1R2.
6	PWMON	I	Modulation select pin. When the input level is low, the boost converter operates as PFM mode. When the input level is high, the boost converter operates as PWM mode.
7	CS	O	Indicator which monitors VBAT pin and VO_BT pin. CS is an open-drain output that goes low when the voltage level of VO_BT pin or VBAT pin is lower than the threshold. The threshold is specified with the Electrical Characteristics.
8	XRESET	O	Indicator that monitors VOUT; the output of 3.3-V LDO or backup battery. XRESET is an open-drain output that goes low when the voltage level of VOUT is lower than the threshold. The threshold is specified with the Electrical Characteristics.
9	VO1R2	O	1.2-V output regulated by LDO. The voltage level sets 1.2 V internally.
10	VO1R8	O	1.8-V output regulated by LDO. The voltage level sets 1.8 V internally.
11	VOUT	O	3.3-V output regulated by LDO or the voltage from backup battery. This output is selected by internal power switch. The selection depends on the output voltage of boost converter.
12	VRO	O	3.3-V output regulated by LDO. The voltage level sets 3.3 V internally.
13	VBK	I	Backup battery input. The recommended input voltage at VBK is from 1.8V to 5.5V.
14	FBG	I	Boost converter output adjustable pin. When the level of PWMON pin is low, the impedance of FBG is high impedance. When the level of PWMON pin is high, the impedance of FBG is almost GND level.
15	FB	I	Feedback voltage from boost converter output.
16	VBAT	I	Power supply from main battery. The recommended input voltage at VBAT is from 2.65V to 5.5V.

(1) I: Input pin, O: Output pin, P: Power supply pin, G: GND pin

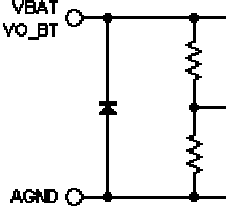
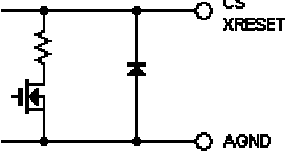
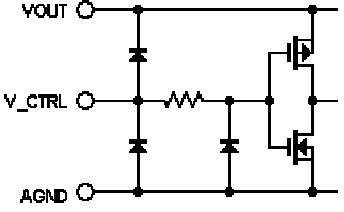
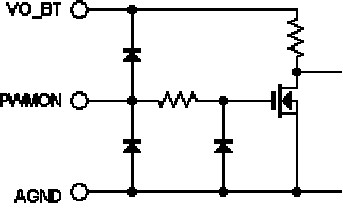
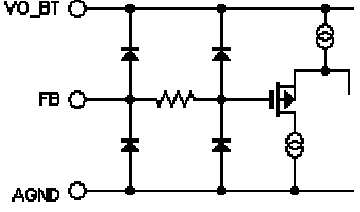
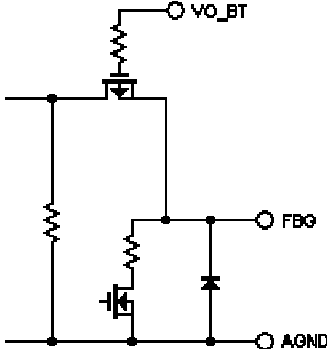
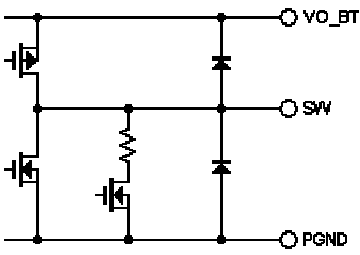
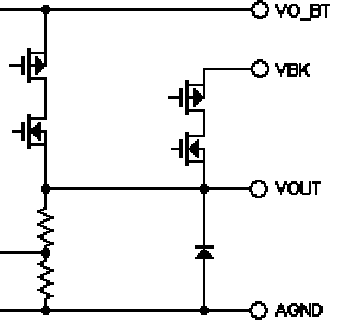
I/O Equivalent Circuits

<p style="text-align: center;">VBAT/VO_BT</p> 	<p style="text-align: center;">CS/XRESET</p> 
<p style="text-align: center;">V_CTRL</p> 	<p style="text-align: center;">PWMON</p> 
<p style="text-align: center;">FB</p> 	<p style="text-align: center;">FBG</p> 
<p style="text-align: center;">SW</p> 	<p style="text-align: center;">VOUT</p> 

I/O Equivalent Circuits (continued)

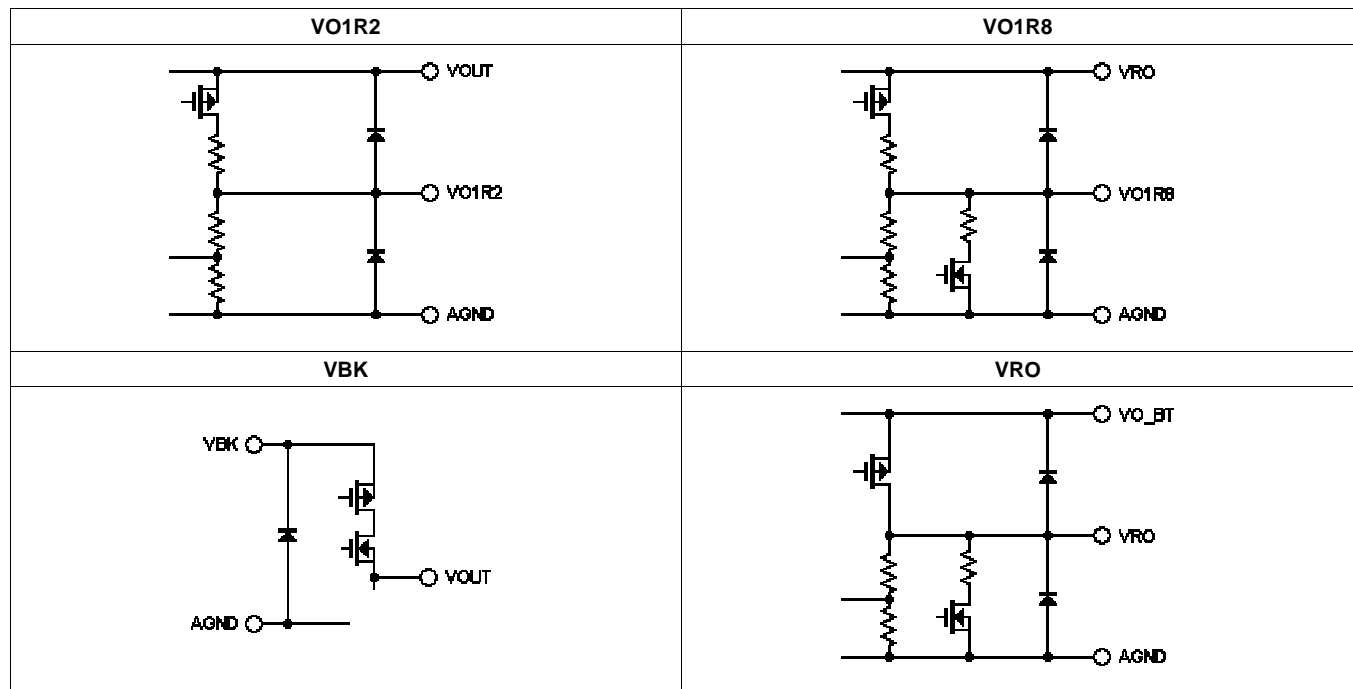

Figure 4. I/O Equivalent Circuits

FUNCTIONAL DESCRIPTION

Power-Path Switch

The TPS65510 has the switch to select a power path of VOUT pin from main battery or backup battery. These switches consist of P-ch MOSFET. Also, these switches avoid the reverse current from output side to battery side.

When the voltage of VO_BT pin (output of boost converter) is higher than the threshold specified by $V_{(SW1)}$ in Electrical Characteristics, the power path of VOUT comes from main battery via internal boost converter. The voltage of VOUT pin sets 3.3 V with internal LDO.

When a voltage of VO_BT pin is lower than the threshold specified by $V_{(SW1)}$ in Electrical Characteristics, the power path of VOUT comes from backup battery at VBK pin. Before the voltage of VO_BT pin reaches $V_{(SW1)}$, the switch to select a power path cannot change the power path route.

The voltage coming from backup battery is not regulated internally. When the voltage of VOUT is lower than the threshold specified by $V_{(XRESET_DET)}$ and $V_{(XRESET_HYS)}$ in Electrical Characteristics, the voltage of XRESET pin goes low (see the description of STATUS INDICATORS).

At the start of boost converter operation, the power path is different to avoid the power supply from backup battery. In this situation, the power path of VOUT comes from main battery via internal boost converter even if the output voltage of VO_BT is lower than threshold for CS signal specified by $V_{(SW1)}$ in Electrical Characteristics.

Boost Converter

The TPS65510 has the boost converter, and the power path comes from the main battery. It has four operation modes, WAKE mode, Pulse Frequency Modulation (PFM) mode, Pulse Width Modulation (PWM) mode and THROUGH mode.

At first, this converter operates as WAKE mode until the voltage of VO_BT pin is less than the threshold specified by $V_{(WAKE_DET)}$ and $V_{(WAKE_HYS)}$ in Electrical Characteristics. The switching frequency of WAKE mode is fixed. Only N-ch MOSFET operates during WAKE mode until the voltage of VO_BT pin reaches the threshold specified by $V_{(WAKE_DET)}$ and $V_{(WAKE_HYS)}$ in Electrical Characteristics.

After the voltage of VO_BT pin reaching more than the threshold specified by $V_{(WAKE_DET)}$ and $V_{(WAKE_HYS)}$ in Electrical Characteristics, the operation mode is shifted from WAKE mode to other modes selected by the level of PWMON pin. When the voltage of PWMON pin is low level, the boost converter operates as PFM mode. When the voltage of PWMON pin is high level, the boost converter operates as PWM mode. When the voltage of main battery is higher than the voltage of VO_BT pin, the converter operates as THROUGH mode to reduce the consumption current at VO_BT pin. At this mode, The TPS65510 forces P-ch MOSFET to be ON and N-ch MOSFET to be OFF. It means that the voltage of VO_BT pin is not regulated.

The boost converter has the reversed current protection to monitor the different voltage between VO_BT pin and SW pin. The protection monitors the difference at both PFM mode and PWM mode. When the voltage of SW pin is larger than that of VO_BT pin, the protection is activated. When the protection is activated, the internal P-ch MOSFET turns OFF. This means that the voltage of SW pin converges the battery voltage naturally.

The output voltage of boost converter depends on the operation mode. When the boost converter operates as PFM mode, the impedance of FBG pin goes Hi-Z and the output voltage is defined by R1, R2 and R3 shown in [Figure 1](#) and [Figure 2](#). When the boost converter operates as PWM mode, the impedance of FBG pin goes almost zero and the output voltage is defined by R1 and R2 shown in [Figure 1](#) and [Figure 2](#). The output voltage is calculated by [Equation 1](#) and [Equation 2](#).

PFM mode:

$$V_{VO_BT} = \left(1 + \frac{R_1}{R_2 + R_3} \right) \cdot V_{FB} \quad (1)$$

PWM mode:

$$V_{VO_BT} = \left(1 + \frac{R_1}{R_2} \right) \cdot V_{FB} \quad (2)$$

Where:

V_{VO_BT} : Voltage of VO_BT pin

V_{FB} : Voltage of FB
pin defined by
reference voltage in
Electrical
Characteristics

LDO Voltage Regulators

The TPS65510 has four types of LDO voltage regulators; 1.2-V output (LDO1, shown in [Figure 3](#)), 1.8-V output (LDO2, shown in [Figure 3](#)) and 3.3-V dual output (LDO3 and LDO4, shown in [Figure 3](#)). These output voltage are set by internal feedback loop only. The device has enable/disable control pin named V_CTRL for LDO1 and LDO2. When the voltage of V_CTRL is low level, the device disables the output of LDO1 and LDO2. When the voltage of V_CTRL is high level, the device enables the output of LDO1 and LDO2.

The power paths of LDO2, LDO3, and LDO4 are fixed; from output of LDO3 for LDO2 and from output of boost converter for LDO3 and LDO4. The power path of LDO1 is selected by power path switch; when output voltage of the boost converter is higher than the threshold specified by $V_{(SW1)}$ in Electrical Characteristics, the path comes from output of LDO4. When output voltage of the boost converter is lower than the threshold specified by $V_{(SW1)}$ in Electrical Characteristics, the path comes from backup battery connected to VBK pin.

The maximum outputs current are specified by $I_{(VO1R2)}$, $I_{(VO1R8)}$, $I_{(VRO)}$ and $I_{(VOUT)}$ in Electrical Characteristics.

Status Indicators

The TPS65510 has two device status indicators; CS and XRESET. These signal pins consist of open drain of N-ch MOSFET. Due to this, the pullup resistors should be needed. The recommended values of pullup resistors are 100 kΩ.

CS function monitors the voltage level of VBAT pin and VO_BT pin for selecting power path of VOUT. When the signal level of CS pin is high level, the power path of VOUT comes from the main battery via the boost converter. When the signal level of CS pin is low level, it comes from backup battery except the starting operation of boost converter. When the boost converter starts operation with the main battery, the P-ch MOSFET at LDO4 turns ON to avoid supplying the power from backup battery even if the voltage of VOUT is lower than the threshold specified by $V_{(SW1)}$ in Electrical Characteristics. The signal of the CS pin remains low level when the main battery is removed (including the transition) or the voltage level of VOUT does not achieve the threshold specified by $V_{(SW2)}$ in Electrical Characteristics.

XRESET function monitors the voltage level of VOUT pin for resetting the load like RTC. When the voltage of VOUT is more than the threshold specified by $V_{(XRESET_DET)}$ and $V_{(XRESET_HYS)}$ in Electrical Characteristics, the signal level of XRESET pin is high. When the voltage of VOUT is less than the threshold specified by $V_{(XRESET_DET)}$ and $V_{(XRESET_HYS)}$ in Electrical Characteristics, the signal level of XRESET pin is low. This situation requires resetting the load. The detailed waveform is shown in [Figure 5](#).

Summary of Status Indicator and Power-Path Switch

	Description	
CS ⁽¹⁾	Detection	Voltage of VO_BT pin
	Detect level	$V_{(CS_DET)}$ and $V_{(CS_HYS)}$ in Electrical Characteristics
Disable CS signal	Detection	Voltage of VOUT pin
	Detect level	$V_{(SW2)}$ in Electrical Characteristics
XRESET	Detection	Voltage of VOUT pin
	Detect level	$V_{(XRESET_DET)}$ and $V_{(XRESET_HYS)}$ in Electrical Characteristics
Power SW ⁽²⁾	Detection of path change	Voltage of VO_BT pin
	Detect level	$V_{(SW1)}$ in Electrical Characteristics

- (1) When the voltage of VBAT pin is less than the threshold of UVLO, the output of CS pin forces low level.
- (2) The Power path switch changes the path after the voltage of VO_BT is higher than $V_{(CS_DET)}$. Before that, the power path of VOUT comes from VO_BT pin; not VBK pin.

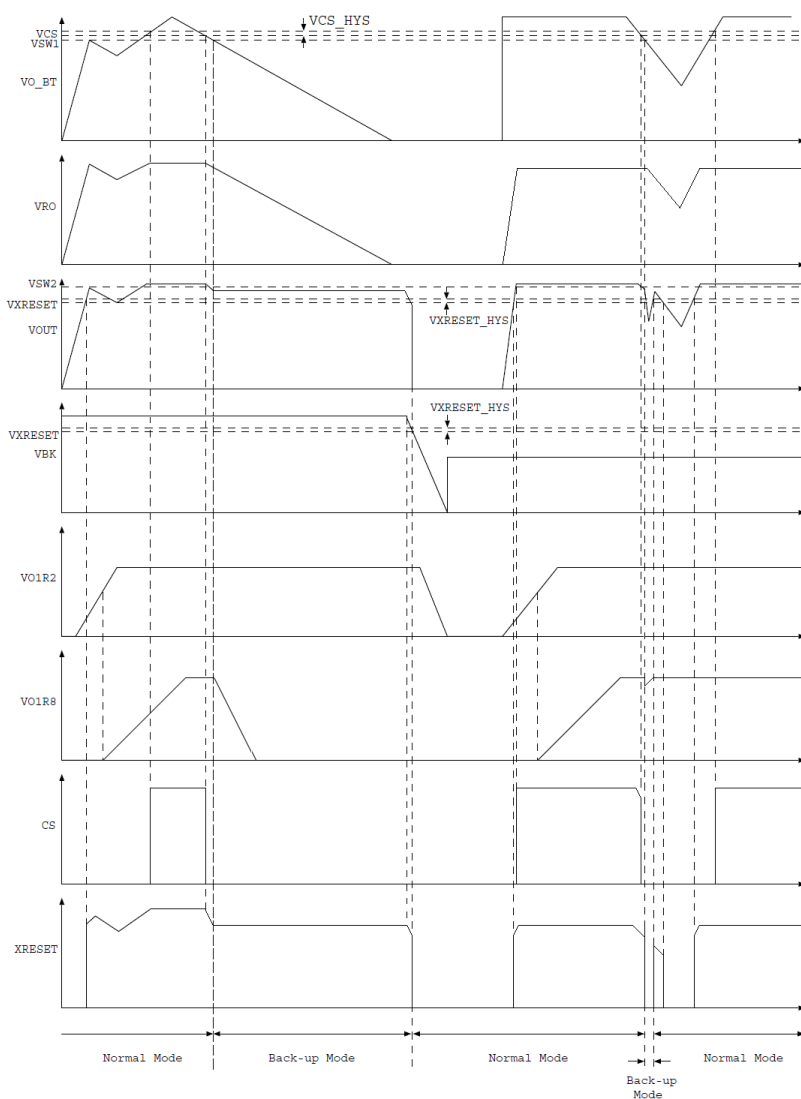

Figure 5. Power-Path Switch Timing Chart

Protection

The TPS65510 has over current protection (OCP), over voltage protection (OVP) Thermal shutdown (TSD) and Under Voltage Lock Out (UVLO). See [Table 1](#).

Table 1. Conditions of Protections

PIN	PROTECTION	CONDITION	
SW	OVP	Detect condition	Voltage of FB pin is greater than the threshold.
		Change mode	Operation disable without latch off
		Recovery condition	Voltage of FB pin is less than the threshold (auto recovery).
	OCP	Detect condition	Current of SW pin is greater than the threshold with counting 64 cycles × 750 [kHz] and the output voltage of VO_BT is less than 85% compared with the target voltage.
		Change mode	Operation mode changes from PWM mode to PFM mode.
		Recovery condition	Current of SW pin is less than the threshold and input edge signal from low level to high level at the PWMON pin.
VOUT	OCP	Detect condition	Current of VOUT pin is greater than the threshold.
		Change mode	Operation disable without latch off
		Recovery condition	Current of VOUT pin is less than the threshold (auto recovery).
VRO	OCP	Detect condition	Current of VRO pin is greater than the threshold.
		Change mode	Operation disable without latch off
		Recovery condition	Current of VRO pin is less than the threshold (auto recovery).
-	TSD	Detect condition	Temperature of chip is greater than the threshold.
		Change mode	Operation of boost converter shuts down with latch off.
		Recovery condition	Temperature of chip is lower than the threshold. Connect the main battery after disconnecting the main battery from the system
VBAT	UVLO	Detect condition	Voltage of VBAT pin is less than the threshold.
		Change mode	Operation of boost converter shutdown without latch off
		Recovery condition	Connect the main battery after disconnecting the main battery from the system.

PACKAGING INFORMATION

Orderable part number	Status (1)	Material type (2)	Package Pins	Package qty Carrier	RoHS (3)	Lead finish/ Ball material (4)	MSL rating/ Peak reflow (5)	Op temp (°C)	Part marking (6)
TPS65510RGTR	Active	Production	VQFN (RGT) 16	3000 LARGE T&R	Yes	NIPDAU	Level-2-260C-1 YEAR	-35 to 85	CGK
TPS65510RGTR.B	Active	Production	VQFN (RGT) 16	3000 LARGE T&R	Yes	NIPDAU	Level-2-260C-1 YEAR	-35 to 85	CGK
TPS65510RGTT	Active	Production	VQFN (RGT) 16	250 SMALL T&R	Yes	NIPDAU	Level-2-260C-1 YEAR	-35 to 85	CGK
TPS65510RGTT.B	Active	Production	VQFN (RGT) 16	250 SMALL T&R	Yes	NIPDAU	Level-2-260C-1 YEAR	-35 to 85	CGK

(1) **Status:** For more details on status, see our [product life cycle](#).

(2) **Material type:** When designated, preproduction parts are prototypes/experimental devices, and are not yet approved or released for full production. Testing and final process, including without limitation quality assurance, reliability performance testing, and/or process qualification, may not yet be complete, and this item is subject to further changes or possible discontinuation. If available for ordering, purchases will be subject to an additional waiver at checkout, and are intended for early internal evaluation purposes only. These items are sold without warranties of any kind.

(3) **RoHS values:** Yes, No, RoHS Exempt. See the [TI RoHS Statement](#) for additional information and value definition.

(4) **Lead finish/Ball material:** Parts may have multiple material finish options. Finish options are separated by a vertical ruled line. Lead finish/Ball material values may wrap to two lines if the finish value exceeds the maximum column width.

(5) **MSL rating/Peak reflow:** The moisture sensitivity level ratings and peak solder (reflow) temperatures. In the event that a part has multiple moisture sensitivity ratings, only the lowest level per JEDEC standards is shown. Refer to the shipping label for the actual reflow temperature that will be used to mount the part to the printed circuit board.

(6) **Part marking:** There may be an additional marking, which relates to the logo, the lot trace code information, or the environmental category of the part.

Multiple part markings will be inside parentheses. Only one part marking contained in parentheses and separated by a "~" will appear on a part. If a line is indented then it is a continuation of the previous line and the two combined represent the entire part marking for that device.

Important Information and Disclaimer: The information provided on this page represents TI's knowledge and belief as of the date that it is provided. TI bases its knowledge and belief on information provided by third parties, and makes no representation or warranty as to the accuracy of such information. Efforts are underway to better integrate information from third parties. TI has taken and continues to take reasonable steps to provide representative and accurate information but may not have conducted destructive testing or chemical analysis on incoming materials and chemicals. TI and TI suppliers consider certain information to be proprietary, and thus CAS numbers and other limited information may not be available for release.

In no event shall TI's liability arising out of such information exceed the total purchase price of the TI part(s) at issue in this document sold by TI to Customer on an annual basis.

TAPE AND REEL INFORMATION

QUADRANT ASSIGNMENTS FOR PIN 1 ORIENTATION IN TAPE

*All dimensions are nominal

Device	Package Type	Package Drawing	Pins	SPQ	Reel Diameter (mm)	Reel Width W1 (mm)	A0 (mm)	B0 (mm)	K0 (mm)	P1 (mm)	W (mm)	Pin1 Quadrant
TPS65510RGTR	VQFN	RGT	16	3000	330.0	12.4	3.3	3.3	1.1	8.0	12.0	Q2
TPS65510RGTT	VQFN	RGT	16	250	180.0	12.4	3.3	3.3	1.1	8.0	12.0	Q2

TAPE AND REEL BOX DIMENSIONS

*All dimensions are nominal

Device	Package Type	Package Drawing	Pins	SPQ	Length (mm)	Width (mm)	Height (mm)
TPS65510RGTR	VQFN	RGT	16	3000	353.0	353.0	32.0
TPS65510RGTT	VQFN	RGT	16	250	213.0	191.0	35.0

RGT 16

GENERIC PACKAGE VIEW

VQFN - 1 mm max height

PLASTIC QUAD FLATPACK - NO LEAD

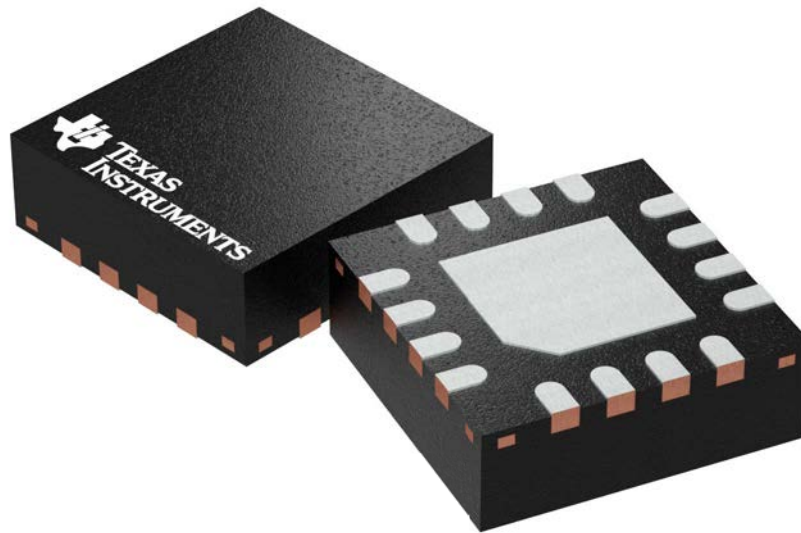

Images above are just a representation of the package family, actual package may vary.
Refer to the product data sheet for package details.

4203495/1

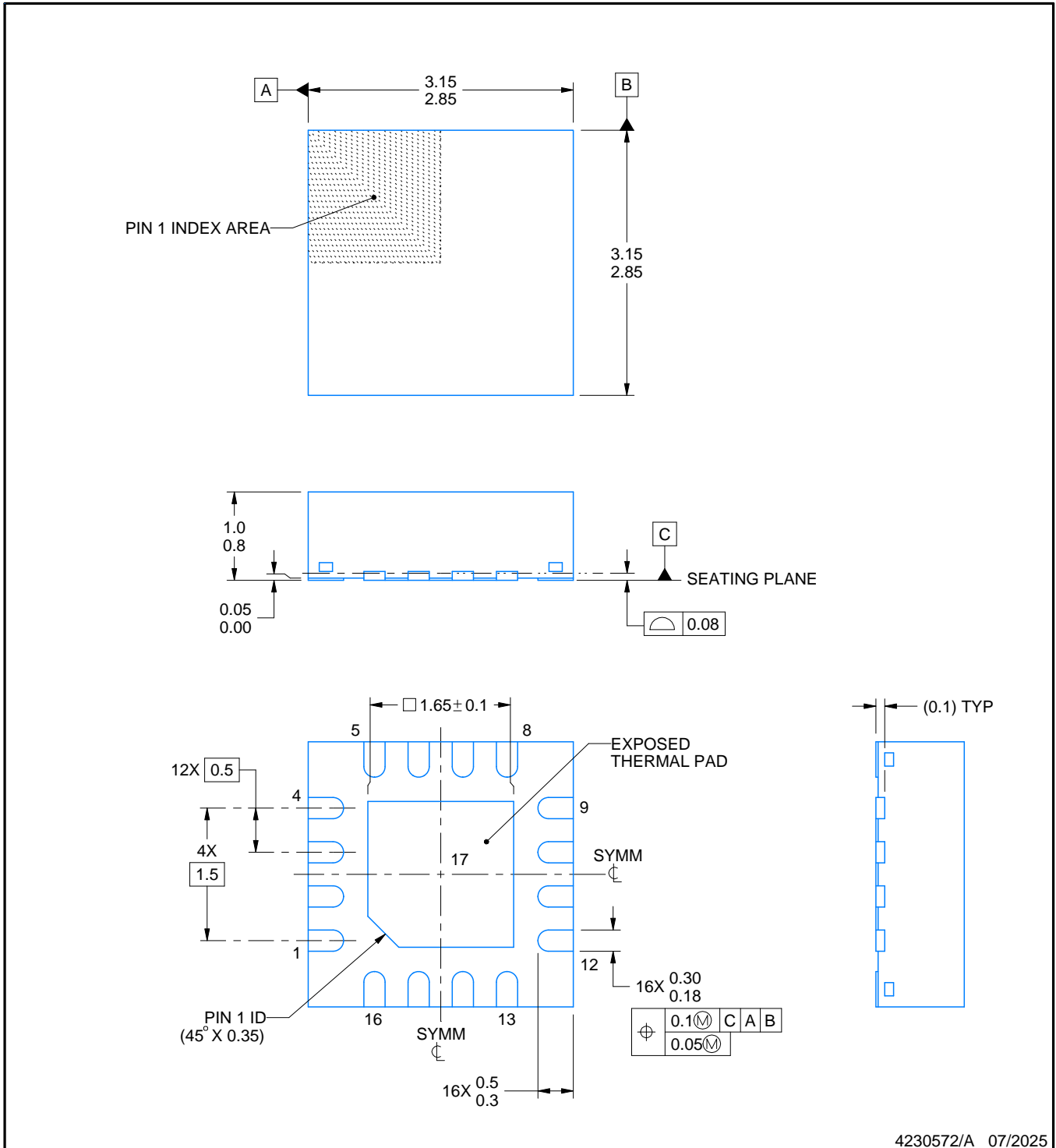
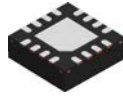

4230572/A 07/2025

NOTES:

1. All linear dimensions are in millimeters. Any dimensions in parenthesis are for reference only. Dimensioning and tolerancing per ASME Y14.5M.
2. This drawing is subject to change without notice.
3. The package thermal pad must be soldered to the printed circuit board for thermal and mechanical performance.

EXAMPLE BOARD LAYOUT

RGT0016F

VQFN - 1 mm max height

PLASTIC QUAD FLATPACK - NO LEAD

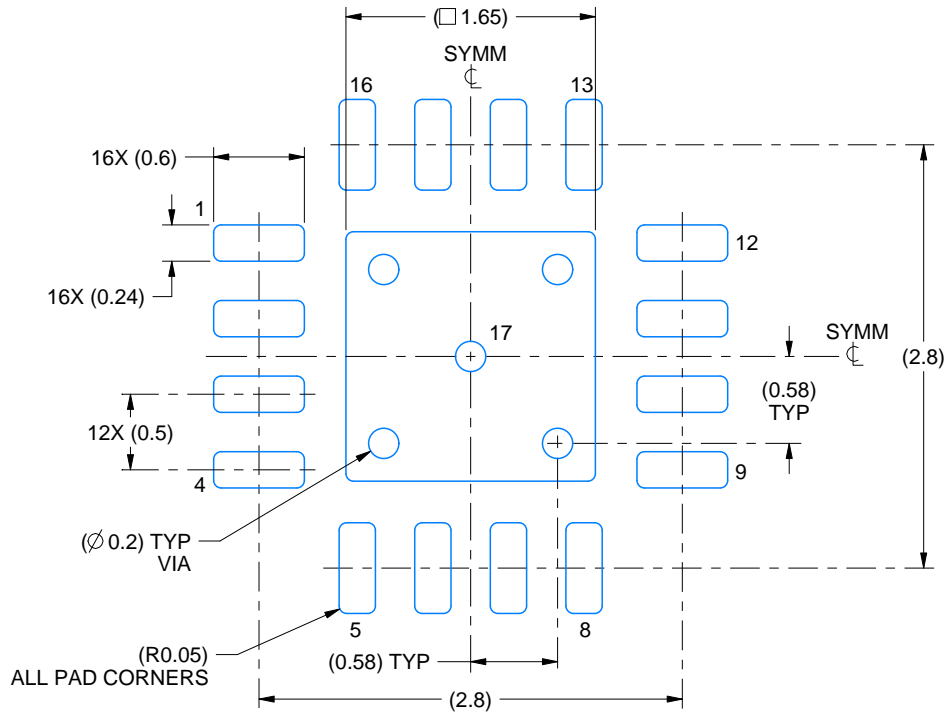

LAND PATTERN EXAMPLE
EXPOSED METAL SHOWN
SCALE:20X

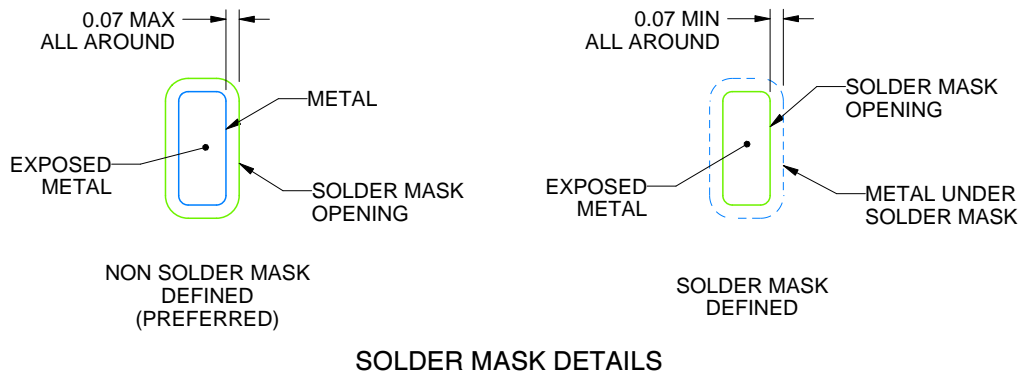

SOLDER MASK DETAILS

4230572/A 07/2025

NOTES: (continued)

4. This package is designed to be soldered to a thermal pad on the board. For more information, see Texas Instruments literature number SLUA271 (www.ti.com/lit/sluea271).
5. Vias are optional depending on application, refer to device data sheet. If any vias are implemented, refer to their locations shown on this view. It is recommended that vias under paste be filled, plugged or tented.

EXAMPLE STENCIL DESIGN

RGT0016F

VQFN - 1 mm max height

PLASTIC QUAD FLATPACK - NO LEAD

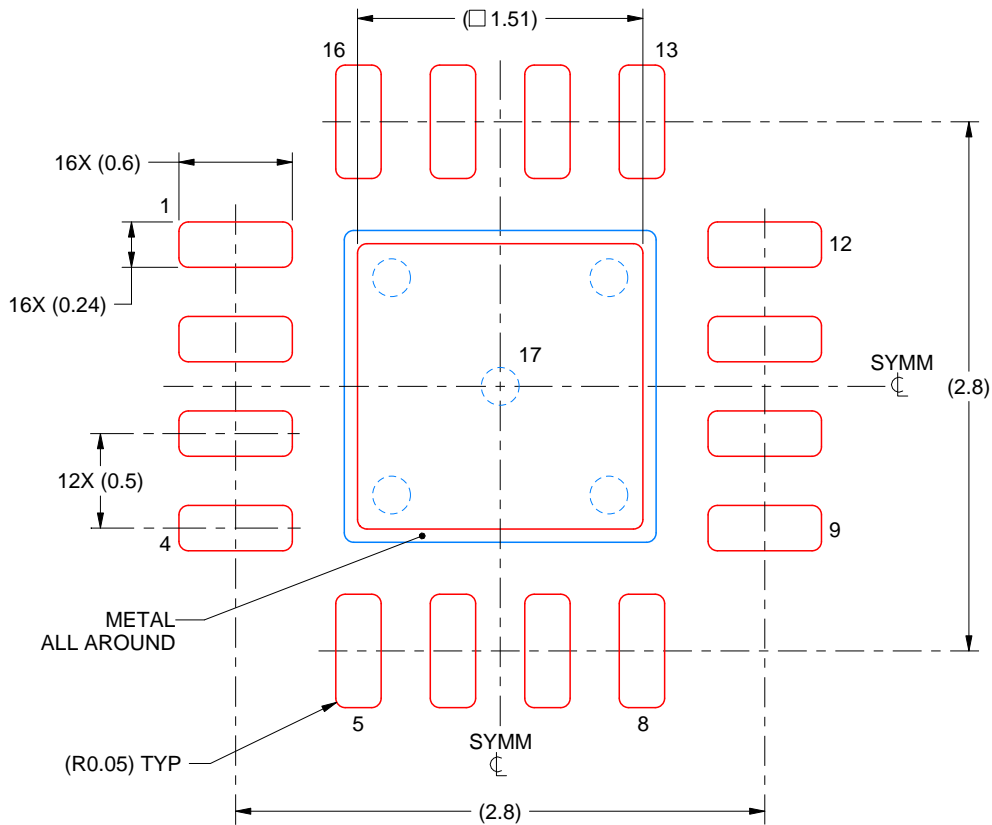

SOLDER PASTE EXAMPLE
BASED ON 0.125 mm THICK STENCIL

EXPOSED PAD 17:
84% PRINTED SOLDER COVERAGE BY AREA UNDER PACKAGE
SCALE:25X

4230572/A 07/2025

NOTES: (continued)

6. Laser cutting apertures with trapezoidal walls and rounded corners may offer better paste release. IPC-7525 may have alternate design recommendations.

IMPORTANT NOTICE AND DISCLAIMER

TI PROVIDES TECHNICAL AND RELIABILITY DATA (INCLUDING DATASHEETS), DESIGN RESOURCES (INCLUDING REFERENCE DESIGNS), APPLICATION OR OTHER DESIGN ADVICE, WEB TOOLS, SAFETY INFORMATION, AND OTHER RESOURCES "AS IS" AND WITH ALL FAULTS, AND DISCLAIMS ALL WARRANTIES, EXPRESS AND IMPLIED, INCLUDING WITHOUT LIMITATION ANY IMPLIED WARRANTIES OF MERCHANTABILITY, FITNESS FOR A PARTICULAR PURPOSE OR NON-INFRINGEMENT OF THIRD PARTY INTELLECTUAL PROPERTY RIGHTS.

These resources are intended for skilled developers designing with TI products. You are solely responsible for (1) selecting the appropriate TI products for your application, (2) designing, validating and testing your application, and (3) ensuring your application meets applicable standards, and any other safety, security, regulatory or other requirements.

These resources are subject to change without notice. TI grants you permission to use these resources only for development of an application that uses the TI products described in the resource. Other reproduction and display of these resources is prohibited. No license is granted to any other TI intellectual property right or to any third party intellectual property right. TI disclaims responsibility for, and you fully indemnify TI and its representatives against any claims, damages, costs, losses, and liabilities arising out of your use of these resources.

TI's products are provided subject to [TI's Terms of Sale](#), [TI's General Quality Guidelines](#), or other applicable terms available either on [ti.com](#) or provided in conjunction with such TI products. TI's provision of these resources does not expand or otherwise alter TI's applicable warranties or warranty disclaimers for TI products. Unless TI explicitly designates a product as custom or customer-specified, TI products are standard, catalog, general purpose devices.

TI objects to and rejects any additional or different terms you may propose.

Copyright © 2025, Texas Instruments Incorporated

Last updated 10/2025