

具有同步降压控制器、2A LDO 和缓冲基准的 TPS51916 完整 DDR2、DDR3、DDR3L 和 DDR4 存储器电源解决方案

1 特性

- 同步降压控制器 (VDDQ)
 - 转换电压范围: 3V 至 28V
 - 输出电压范围: 0.7V 至 1.8V
 - 0.8% V_{REF} 精度
 - 可选控制架构
 - D-CAP™ 模式, 可实现快速瞬态响应
 - D-CAP2™ 针对陶瓷输出电容器的模式
 - 可选 300kHz、400kHz、500kHz 或 670kHz 开关频率
 - 自动跳过功能优化了轻负载和重负载时的效率
 - 支持 S4 和 S5 状态下的软关闭
 - 过流 (OCL) / 过压 (OVP) / 欠压 (UVP) / 欠压闭锁 (UVLO) 保护
 - 电源正常输出
- 2A LDO (VTT), 缓冲基准 (VTTREF)
 - 2A (峰值) 灌电流和拉电流
 - 经缓冲的, 低噪声, 10mA VTTREF 输出
 - 0.8% VTTREF, 20mV VTT 精度
 - 支持高阻抗 (S3) 和软关闭 (S4、S5)
- 热关断
- 20 引脚, 3mm x 3mm, 四方扁平无引线 (QFN) 封装
- 创建 [WEBENCH](#) 设计

2 应用

- 存储器电源: DDR2、DDR3、DDR3L、DDR4
- 终端: SSTL_18、SSTL_15、SSTL_135、HSTL

3 说明

TPS51916 器件能够以最少总成本和最小空间为 DDR2、DDR3、DDR3L 和 DDR4 存储器系统提供完整的电源。它将同步降压稳压器控制器 (VDDQ) 与 2A 灌电流和 2A 拉电流跟踪 LDO (VTT) 以及缓冲低噪声基准 (VTTREF) 集成在一起。

该器件采用耦合了 300kHz 或 400kHz 频率的 D-CAP™ 模式, 以实现易于使用且快速的瞬态响应, 或采用耦合了更高的 500kHz 或 670kHz 频率的 D-CAP2™ 模式, 以在无需外部补偿电路的情况下支持陶瓷输出电容器。VTTREF 跟踪 $VDDQ/2$ 的精度优于 0.8%。能够提供 2A 灌电流和 2A 拉电流峰值电流功能的 VTT 只需 10 μ F 的陶瓷电容。提供专用的 LDO 电源输入。

该器件还可以提供卓越的电源性能。它支持灵活功率级控制, 将 VTT 置于高阻抗状态 (处于 S3) 并在 S4 或 S5 状态下对 VDDQ、VTT 和 VTTREF 进行放电 (软关闭)。它还提供具有低侧 MOSFET $R_{DS(on)}$ 检测功能的可编程 OCL、OVP、UVP、UVLO 以及热关断保护。

器件信息(1)

器件型号	封装	封装尺寸 (标称值)
TPS51916	QFN (20)	3mm x 3mm

(1) 如需了解所有可用封装, 请参阅数据表末尾的可订购产品附录。

简化应用

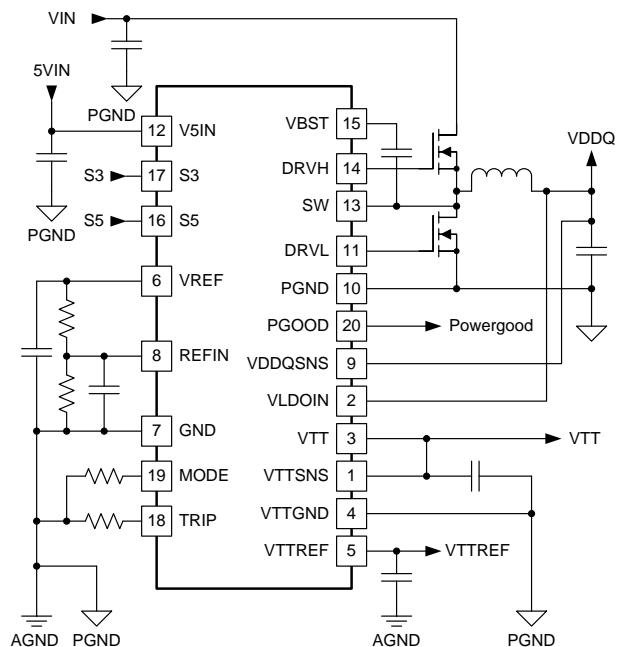

目录

1	特性	1	7.4	Device Functional Modes.....	20
2	应用	1	7.5	D-CAP2™ Mode Operation	22
3	说明	1	8	Application and Implementation	23
4	修订历史记录	2	8.1	Application Information.....	23
5	Pin Configuration and Functions	3	9	Power Supply Recommendations	28
6	Specifications.....	4	10	Layout.....	28
6.1	Absolute Maximum Ratings	4	10.1	Layout Guidelines	28
6.2	ESD Ratings.....	4	10.2	Layout Example	31
6.3	Recommended Operating Conditions.....	5	11	器件和文档支持	32
6.4	Thermal Information	5	11.1	接收文档更新通知	32
6.5	Electrical Characteristics.....	6	11.2	社区资源	32
6.6	Typical Characteristics	9	11.3	商标	32
7	Detailed Description	15	11.4	静电放电警告.....	32
7.1	Overview	15	11.5	术语表	32
7.2	Functional Block Diagram	15	12	机械、封装和可订购信息.....	32
7.3	Feature Description.....	16			

4 修订历史记录

Changes from Revision E (August 2016) to Revision F Page

- Changed *VLDOIN discharge current* test condition from "Non-tracking" to "Tracking" in [Electrical Characteristics](#) table **6**

Changes from Revision D (June 2012) to Revision E Page

- 已添加 添加了引脚配置和功能 部分、ESD 额定值表、特性 说明 部分、器件功能模式、应用和实施 部分、电源建议 部分、布局 部分、器件和文档支持 部分、接收文档更新通知 部分、社区资源 部分以及机械、封装和可订购信息 部分..... **1**
- Changed Minimum S3 or S5 high-level voltage from "1.8 V" to "1.5 V" in [Electrical Characteristics](#) table **7**

Changes from Revision C (March 2012) to Revision D Page

- Added clarity to **15**
- Added more information to [VTT and VTTREF](#) section. **18**
- Added clarity to [Figure 38](#)..... **22**

5 Pin Configuration and Functions

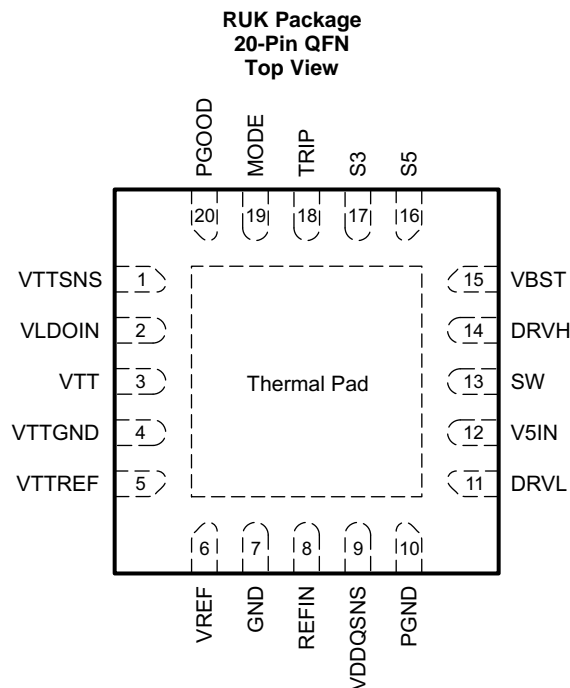

Pin Functions

PIN		I/O	DESCRIPTION
NAME	NO.		
DRVH	14	O	High-side MOSFET gate driver output.
DRVH	11	O	Low-side MOSFET gate driver output.
GND	7	–	Signal ground.
MODE	19	I	Connect resistor to GND to configure switching frequency, control mode and discharge mode. (See Table 2)
PGND	10	–	Gate driver power ground. $R_{DS(on)}$ current sensing input(+).
PGOOD	20	O	Powergood signal open drain output. PGOOD goes high when VDDQ output voltage is within the target range.
REFIN	8	I	Reference input for VDDQ. Connect to the midpoint of a resistor divider from VREF to GND. Add a capacitor for stable operation.
SW	13	I/O	High-side MOSFET gate driver return. $R_{DS(on)}$ current sensing input(-).
S3	17	I	S3 signal input. (See Table 1)
S5	16	I	S5 signal input. (See Table 1)
TRIP	18	I	Connect resistor to GND to set OCL at $V_{TRIP}/8$. Output 10- μ A current at room temperature, $T_C = 4700$ ppm/ $^{\circ}$ C.
VBST	15	I	High-side MOSFET gate driver bootstrap voltage input. Connect a capacitor from the VBST pin to the SW pin.
VDDQSNS	9	I	VDDQ output voltage feedback. Reference input for VTTREF. Also serves as power supply for VTTREF.
VLDOIN	2	I	Power supply input for VTT LDO. Connect VDDQ in typical application.
VREF	6	O	1.8-V reference output.
VTT	3	O	VTT 2-A LDO output. Need to connect at least 10 μ F of capacitance for stability.
VTTGND	4	–	Power ground for VTT LDO.
VTTREF	5	O	Buffered VTT reference output. Need to connect 0.22 μ F or larger capacitance for stability.
VTTSENS	1	I	VTT output voltage feedback.
V5IN	12	I	5-V power supply input for internal circuits and MOSFET gate drivers.
Thermal pad	–	–	Thermal pad. Connect directly to system GND plane with multiple vias.

6 Specifications

6.1 Absolute Maximum Ratings

 over operating free-air temperature range (unless otherwise noted)⁽¹⁾

		MIN	MAX	UNIT
Input voltage ⁽²⁾	VBST	–0.3	36	V
	VBST ⁽³⁾	–0.3	6	
	SW	–5	30	
	VLDOIN, VDDQSNS, REFIN	–0.3	3.6	
	VTTSENS	–0.3	3.6	
	PGND, VTTGND	–0.3	0.3	
	V5IN, S3, S5, TRIP, MODE	–0.3	6	
Output voltage ⁽²⁾	DRVH	–5	36	V
	DRVH ⁽³⁾	–0.3	6	
	VTTREF, VREF	–0.3	3.6	
	VTT	–0.3	3.6	
	DRVL	–0.3	6	
	PGOOD	–0.3	6	
Junction temperature, T _J			125	°C
Storage temperature, T _{STG}		–55	150	°C

(1) Stresses beyond those listed under *Absolute Maximum Ratings* may cause permanent damage to the device. These are stress ratings only, which do not imply functional operation of the device at these or any other conditions beyond those indicated under *Recommended Operating Conditions*. Exposure to absolute-maximum-rated conditions for extended periods may affect device reliability.

(2) All voltage values are with respect to the network ground terminal unless otherwise noted.

(3) Voltage values are with respect to the SW terminal.

6.2 ESD Ratings

		VALUE	UNIT
V _(ESD)	Electrostatic discharge	Human-body model (HBM), per ANSI/ESDA/JEDEC JS-001 ⁽¹⁾	±2000
		Charged-device model (CDM), per JEDEC specification JESD22-C101 ⁽²⁾	±1500

(1) JEDEC document JEP155 states that 500-V HBM allows safe manufacturing with a standard ESD control process.

(2) JEDEC document JEP157 states that 250-V CDM allows safe manufacturing with a standard ESD control process.

6.3 Recommended Operating Conditions

over operating free-air temperature range (unless otherwise noted)

		MIN	NOM	MAX	UNIT
Supply voltage	V5IN	4.5		5.5	V
Input voltage	VBST	-0.1		33.5	V
	VBST	-0.1		5.5	
	SW	-3		28	
	SW	-4.5		28	
	VLDOIN, VDDQSNS, REFIN	-0.1		3.5	
	VTTSENS	-0.1		3.5	
	PGND, VTTGND	-0.1		0.1	
Output voltage	S3, S5, TRIP, MODE	-0.1		5.5	V
	DRVH	-3		33.5	
	DRVH-SW	-0.1		5.5	
	DRVH (less than 30% of repetitive period)	-4.5		33.5	
	VTTREF, VREF	-0.1		3.5	
	VTT	-0.1		3.5	
	DRVL	-0.1		5.5	
PGOOD	-0.1		5.5		
T _A	Ambient temperature	-40		85	°C

6.4 Thermal Information

THERMAL METRIC ⁽¹⁾		TPS51916	UNIT
		RUK (QFN)	
		20 PINS	
R _{θJA}	Junction-to-ambient thermal resistance	94.1	°C/W
R _{θJC(top)}	Junction-to-case (top) thermal resistance	58.1	°C/W
R _{θJB}	Junction-to-board thermal resistance	64.3	°C/W
ψ _{JT}	Junction-to-top characterization parameter	31.8	°C/W
ψ _{JB}	Junction-to-board characterization parameter	58.0	°C/W
R _{θJC(bot)}	Junction-to-case (bottom) thermal resistance	5.9	°C/W

- (1) For more information about traditional and new thermal metrics, see the [Semiconductor and IC Package Thermal Metrics](#) application report.

6.5 Electrical Characteristics

over operating free-air temperature range, $V_{V5IN} = 5\text{ V}$, VLDOIN is connected to VDDQ output, $V_{MODE} = 0\text{ V}$, $V_{S3} = V_{S5} = 5\text{ V}$ (unless otherwise noted)

PARAMETER		TEST CONDITION	MIN	TYP	MAX	UNIT
SUPPLY CURRENT						
$I_{V5IN(S0)}$	V5IN supply current, in S0	$T_A = 25^\circ\text{C}$, No load, $V_{S3} = V_{S5} = 5\text{ V}$		590		μA
$I_{V5IN(S3)}$	V5IN supply current, in S3	$T_A = 25^\circ\text{C}$, No load, $V_{S3} = 0\text{ V}$, $V_{S5} = 5\text{ V}$		500		μA
$I_{V5INSDN}$	V5IN shutdown current	$T_A = 25^\circ\text{C}$, No load, $V_{S3} = V_{S5} = 0\text{ V}$			1	μA
$I_{VLDOIN(S0)}$	VLDOIN supply current, in S0	$T_A = 25^\circ\text{C}$, No load, $V_{S3} = V_{S5} = 5\text{ V}$			5	μA
$I_{VLDOIN(S3)}$	VLDOIN supply current, in S3	$T_A = 25^\circ\text{C}$, No load, $V_{S3} = 0\text{ V}$, $V_{S5} = 5\text{ V}$			5	μA
$I_{VLDOINSDN}$	VLDOIN shutdown current	$T_A = 25^\circ\text{C}$, No load, $V_{S3} = V_{S5} = 0\text{ V}$			5	μA
VREF OUTPUT						
V_{VREF}	Output voltage	$I_{VREF} = 30\ \mu\text{A}$, $T_A = 25^\circ\text{C}$		1.8000		V
		$0\ \mu\text{A} \leq I_{VREF} < 300\ \mu\text{A}$, $T_A = -10^\circ\text{C}$ to 85°C	1.7856		1.8144	
		$0\ \mu\text{A} \leq I_{VREF} < 300\ \mu\text{A}$, $T_A = -40^\circ\text{C}$ to 85°C	1.7820		1.8180	
$I_{VREFOCL}$	Current limit	$V_{VREF} = 1.7\text{ V}$	0.4	0.8		mA
VTTREF OUTPUT						
V_{VTTREF}	Output voltage			$V_{VDDQSNS}/2$		V
V_{VTTREF}	Output voltage tolerance to V_{VDDQ}	$ I_{VTTREF} < 100\ \mu\text{A}$, $1.2\text{ V} \leq V_{VDDQSNS} \leq 1.8\text{ V}$	49.2%		50.8%	
		$ I_{VTTREF} < 10\ \text{mA}$, $1.2\text{ V} \leq V_{VDDQSNS} \leq 1.8\text{ V}$	49%		51%	
$I_{VTTREFOCLSRC}$	Source current limit	$V_{VDDQSNS} = 1.8\text{ V}$, $V_{VTTREF} = 0\text{ V}$	10	18		mA
$I_{VTTREFOCLSNK}$	Sink current limit	$V_{VDDQSNS} = 1.8\text{ V}$, $V_{VTTREF} = 1.8\text{ V}$	10	17		mA
$I_{VTTREFDIS}$	VTTREF discharge current	$T_A = 25^\circ\text{C}$, $V_{S3} = V_{S5} = 0\text{ V}$, $V_{VTTREF} = 0.5\text{ V}$	0.8	1.3		mA
VTT OUTPUT						
V_{VTT}	Output voltage			V_{VTTREF}		V
V_{VTTTOL}	Output voltage tolerance to VTTREF	$ I_{VTT} \leq 10\ \text{mA}$, $1.2\text{ V} \leq V_{VDDQSNS} \leq 1.8\text{ V}$, $I_{VTTREF} = 0\ \text{A}$	-20		20	mV
		$ I_{VTT} \leq 1\ \text{A}$, $1.2\text{ V} \leq V_{VDDQSNS} \leq 1.8\text{ V}$, $I_{VTTREF} = 0\ \text{A}$	-30		30	
		$ I_{VTT} \leq 2\ \text{A}$, $1.4\text{ V} \leq V_{VDDQSNS} \leq 1.8\text{ V}$, $I_{VTTREF} = 0\ \text{A}$	-40		40	
		$ I_{VTT} \leq 1.5\ \text{A}$, $1.2\text{ V} \leq V_{VDDQSNS} \leq 1.4\text{ V}$, $I_{VTTREF} = 0\ \text{A}$	-40		40	
$I_{VTTOCLSRC}$	Source current limit	$V_{VDDQSNS} = 1.8\text{ V}$, $V_{VTT} = V_{VTTNS} = 0.7\text{ V}$, $I_{VTTREF} = 0\ \text{A}$	2	3		A
$I_{VTTOCLSNK}$	Sink current limit	$V_{VDDQSNS} = 1.8\text{ V}$, $V_{VTT} = V_{VTTNS} = 1.1\text{ V}$, $I_{VTTREF} = 0\ \text{A}$	2	3		A
I_{VTTLK}	Leakage current	$T_A = 25^\circ\text{C}$, $V_{S3} = 0\text{ V}$, $V_{S5} = 5\text{ V}$, $V_{VTT} = V_{VTTREF}$			5	μA
$I_{VTTNSBIAS}$	VTTNS input bias current	$V_{S3} = 5\text{ V}$, $V_{S5} = 5\text{ V}$, $V_{VTTNS} = V_{VTTREF}$	-0.5	0.0	0.5	μA
$I_{VTTNSLK}$	VTTNS leakage current	$V_{S3} = 0\text{ V}$, $V_{S5} = 5\text{ V}$, $V_{VTTNS} = V_{VTTREF}$	-1	0	1	μA
I_{VTTDIS}	VTT Discharge current	$T_A = 25^\circ\text{C}$, $V_{S3} = V_{S5} = 0\text{ V}$, $V_{VDDQSNS} = 1.8\text{ V}$, $V_{VTT} = 0.5\text{ V}$, $I_{VTTREF} = 0\ \text{A}$		7.8		mA
VDDQ OUTPUT						
$V_{VDDQSNS}$	VDDQ sense voltage			V_{REFIN}		
$V_{VDDQSNSSTOL}$	VDDQSNS regulation voltage tolerance to REFIN	$T_A = 25^\circ\text{C}$	-3		3	mV
$I_{VDDQSNS}$	VDDQSNS input current	$V_{VDDQSNS} = 1.8\text{ V}$		39		μA
I_{REFIN}	REFIN input current	$V_{REFIN} = 1.8\text{ V}$	-0.1	0.0	0.1	μA
$I_{VDDQDIS}$	VDDQ discharge current	$V_{S3} = V_{S5} = 0\text{ V}$, $V_{VDDQSNS} = 0.5\text{ V}$, MODE pin pulled down to GND through 47 k Ω (Non-tracking)		12		mA
$I_{VLDOINDIS}$	VLDOIN discharge current	$V_{S3} = V_{S5} = 0\text{ V}$, $V_{VDDQSNS} = 0.5\text{ V}$, MODE pin pulled down to GND through 100 k Ω (Tracking)		1.2		A

Electrical Characteristics (continued)

over operating free-air temperature range, $V_{V5IN} = 5\text{ V}$, VLDOIN is connected to VDDQ output, $V_{MODE} = 0\text{ V}$, $V_{S3} = V_{S5} = 5\text{ V}$ (unless otherwise noted)

PARAMETER	TEST CONDITION	MIN	TYP	MAX	UNIT		
SWITCH MODE POWER SUPPLY (SMPS) FREQUENCY							
f_{SW}	VDDQ switching frequency	$V_{IN} = 12\text{ V}$, $V_{VDDQSNS} = 1.8\text{ V}$, $R_{MODE} = 100\text{ k}\Omega$	300		kHz		
		$V_{IN} = 12\text{ V}$, $V_{VDDQSNS} = 1.8\text{ V}$, $R_{MODE} = 200\text{ k}\Omega$	400				
		$V_{IN} = 12\text{ V}$, $V_{VDDQSNS} = 1.8\text{ V}$, $R_{MODE} = 1\text{ k}\Omega$	500				
		$V_{IN} = 12\text{ V}$, $V_{VDDQSNS} = 1.8\text{ V}$, $R_{MODE} = 12\text{ k}\Omega$	670				
$t_{ON(min)}$	Minimum on-time ⁽¹⁾	DRVH rising to falling		60	ns		
$t_{OFF(min)}$	Minimum off-time	DRVH falling to rising		200 320 450			
VDDQ MOSFET DRIVER							
R_{DRVH}	DRVH resistance	Source, $I_{DRVH} = -50\text{ mA}$	1.6	3.0	Ω		
		Sink, $I_{DRVH} = 50\text{ mA}$	0.6	1.5			
R_{DRVL}	DRVL resistance	Source, $I_{DRVL} = -50\text{ mA}$	0.9	2.0			
		Sink, $I_{DRVL} = 50\text{ mA}$	0.5	1.2			
t_{DEAD}	Dead time	DRVH-off to DRVL-on	10		ns		
		DRVL-off to DRVH-on	20				
INTERNAL BOOT STRAP SW							
V_{FBST}	Forward voltage	$V_{V5IN-VBST}$, $T_A = 25^\circ\text{C}$, $I_F = 10\text{ mA}$		0.1	0.2	V	
I_{VBSTLK}	VBST leakage current	$T_A = 25^\circ\text{C}$, $V_{VBST} = 33\text{ V}$, $V_{SW} = 28\text{ V}$		0.01	1.5	μA	
LOGIC THRESHOLD							
I_{MODE}	MODE source current		14	15	16	μA	
V_{THMODE}	MODE threshold voltage	MODE 0-1	109	129	149	mV	
		MODE 1-2	235	255	275		
		MODE 2-3	392	412	432		
		MODE 3-4	580	600	620		
		MODE 4-5	829	854	879		
		MODE 5-6	1202	1232	1262		
		MODE 6-7	1760	1800	1840		
V_{IL}	S3 or S5 low-level voltage				0.5	V	
V_{IH}	S3 or S5 high-level voltage	1.5					
V_{IHYST}	S3 or S5 hysteresis voltage		0.25				
I_{ILK}	S3 or S5 input leak current		-1	0	1	μA	
SOFT START							
t_{SS}	VDDQ soft-start time	Internal soft-start time, $C_{VREF} = 0.1\text{ }\mu\text{F}$, S5 rising to $V_{VDDQSNS} > 0.99 \times V_{REFIN}$		1.1		ms	
PGOOD COMPARATOR							
V_{THPG}	VDDQ PGOOD threshold	PGOOD in from higher	106%	108%	110%		
		PGOOD in from lower	90%	92%	94%		
		PGOOD out to higher	114%	116%	118%		
		PGOOD out to lower	82%	84%	86%		
I_{PG}	PGOOD sink current	$V_{PGOOD} = 0.5\text{ V}$		3	5.9	mA	
t_{PGDLY}	PGOOD delay time	Delay for PGOOD in		0.8	1	1.2	ms
		Delay for PGOOD out, with 100 mV over drive			330		ns
$t_{PGSSDLY}$	PGOOD start-up delay	$C_{VREF} = 0.1\text{ }\mu\text{F}$, S5 rising to PGOOD rising			2.5	ms	

(1) Ensured by design. Not production tested.

Electrical Characteristics (continued)

over operating free-air temperature range, $V_{V5IN} = 5\text{ V}$, VLDOIN is connected to VDDQ output, $V_{MODE} = 0\text{ V}$, $V_{S3} = V_{S5} = 5\text{ V}$ (unless otherwise noted)

PARAMETER		TEST CONDITION	MIN	TYP	MAX	UNIT
PROTECTIONS						
I_{TRIP}	TRIP source current	$T_A = 25^\circ\text{C}$, $V_{TRIP} = 0.4\text{ V}$	9	10	11	μA
T_{CITRIP}	TRIP source current temperature coefficient ⁽¹⁾			4700		ppm/ $^\circ\text{C}$
V_{TRIP}	V_{TRIP} voltage range		0.2		3	V
V_{OCL}	Current limit threshold	$V_{TRIP} = 3.0\text{ V}$	360	375	390	mV
		$V_{TRIP} = 1.6\text{ V}$	190	200	210	
		$V_{TRIP} = 0.2\text{ V}$	20	25	30	
V_{OCLN}	Negative current limit threshold	$V_{TRIP} = 3.0\text{ V}$	-390	-375	-360	mV
		$V_{TRIP} = 1.6\text{ V}$	-210	-200	-190	
		$V_{TRIP} = 0.2\text{ V}$	-30	-25	-20	
V_{ZC}	Zero cross detection offset		0			mV
V_{UVLO}	V5IN UVLO threshold voltage	Wake-up	4.2	4.4	4.5	V
		Shutdown	3.7	3.9	4.1	
V_{OVP}	VDDQ OVP threshold voltage	OVP detect voltage	118%	120%	122%	
t_{OVPDLY}	VDDQ OVP propagation delay	With 100 mV over drive		430		ns
V_{UVP}	VDDQ UVP threshold voltage	UVP detect voltage	66%	68%	70%	
t_{UVPDLY}	VDDQ UVP delay			1		ms
$t_{UVPENDLY}$	VDDQ UVP enable delay			1.2		ms
V_{OOB}	OOB Threshold voltage			108%		
THERMAL SHUTDOWN						
T_{SDN}	Thermal shutdown threshold ⁽¹⁾	Shutdown temperature		140		$^\circ\text{C}$
		Hysteresis		10		

6.6 Typical Characteristics

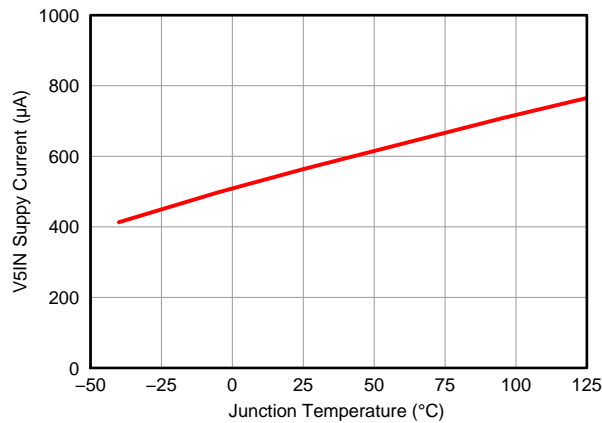

Figure 1. V5IN Supply Current vs Junction Temperature

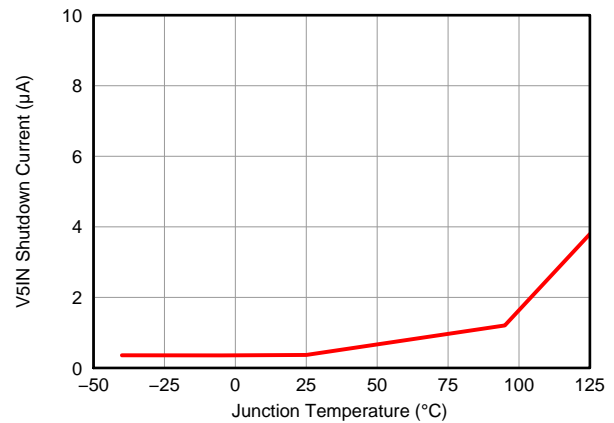

Figure 2. V5IN Shutdown Current vs Junction Temperature

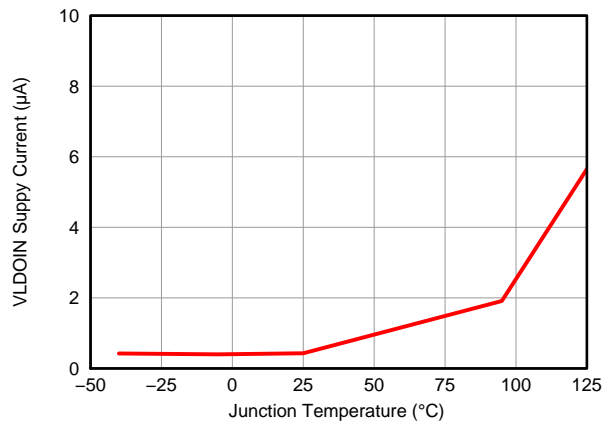

Figure 3. VLDOIN Supply Current vs Junction Temperature

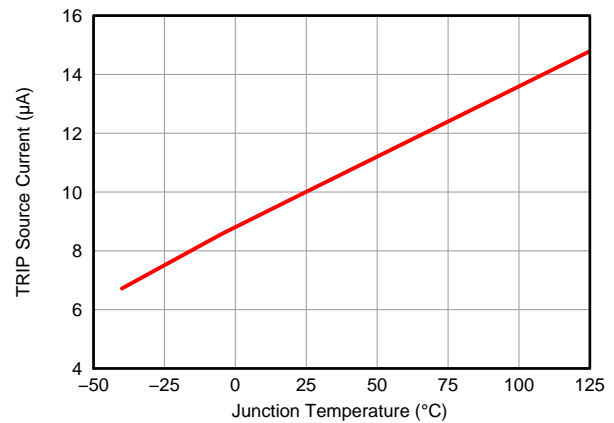

Figure 4. Current Sense Current vs Junction Temperature

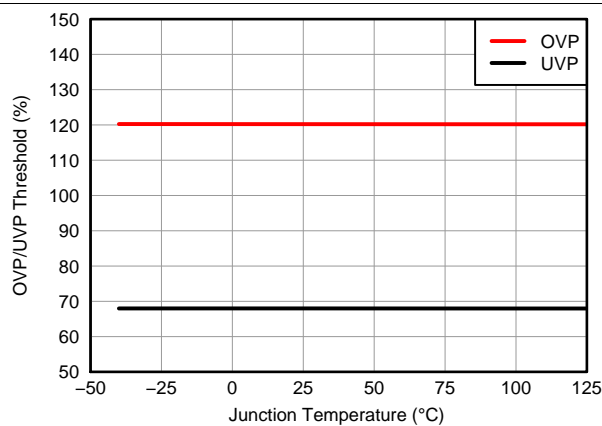

Figure 5. OVP/UVP Threshold vs Junction Temperature

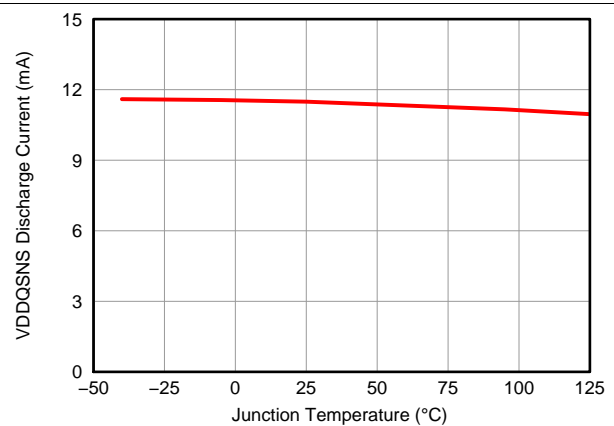

Figure 6. VDDQSNS Discharge Current vs Junction Temperature

Typical Characteristics (continued)

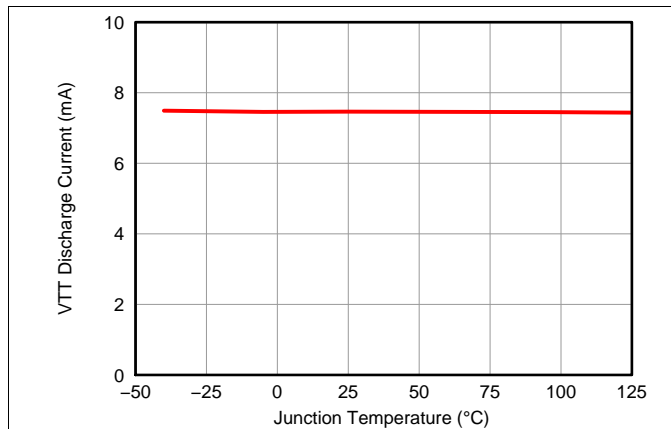

Figure 7. VTT Discharge Current vs Junction Temperature

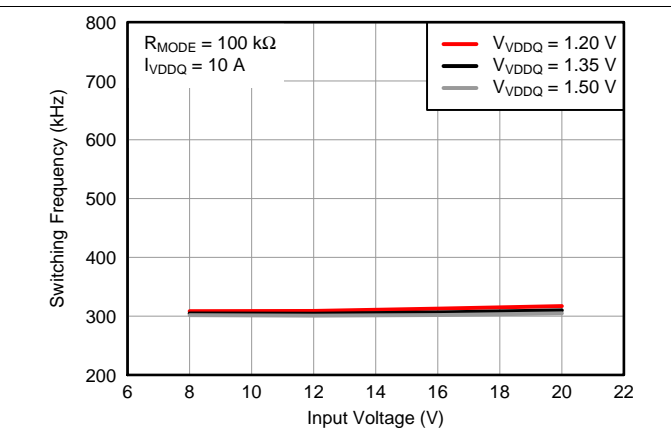

Figure 8. Switching Frequency vs Input Voltage

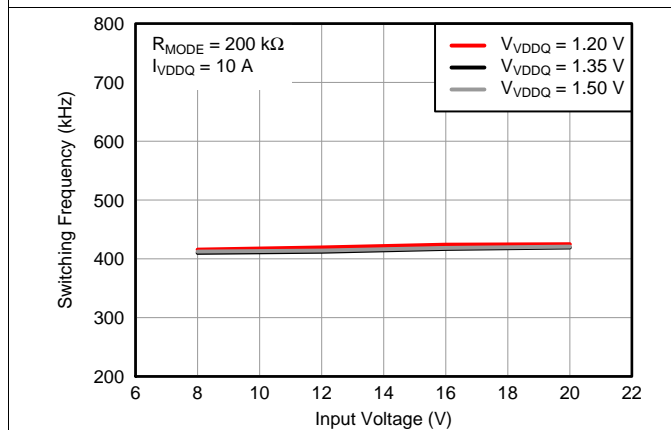

Figure 9. Switching Frequency vs Input Voltage

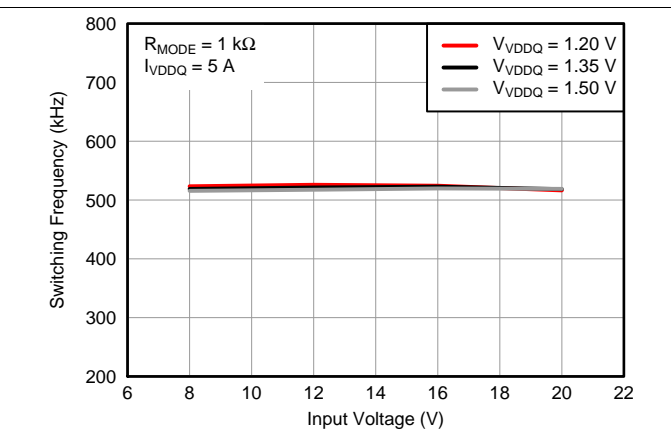

Figure 10. Switching Frequency vs Input Voltage

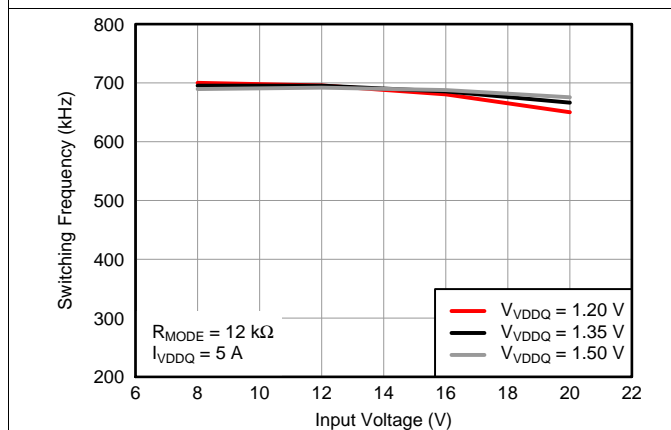

Figure 11. Switching Frequency vs Input Voltage

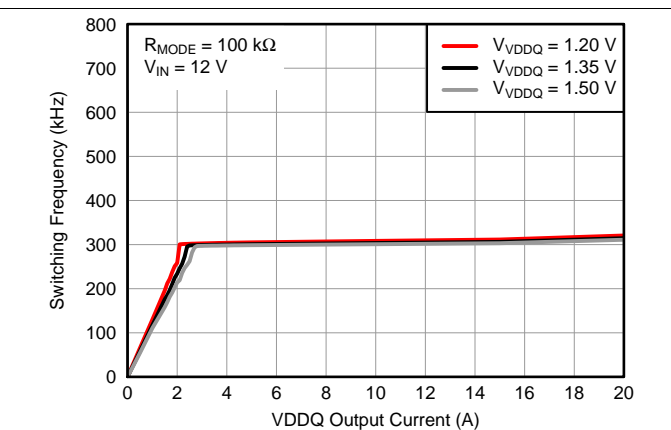

Figure 12. Switching Frequency vs Load Current

Typical Characteristics (continued)

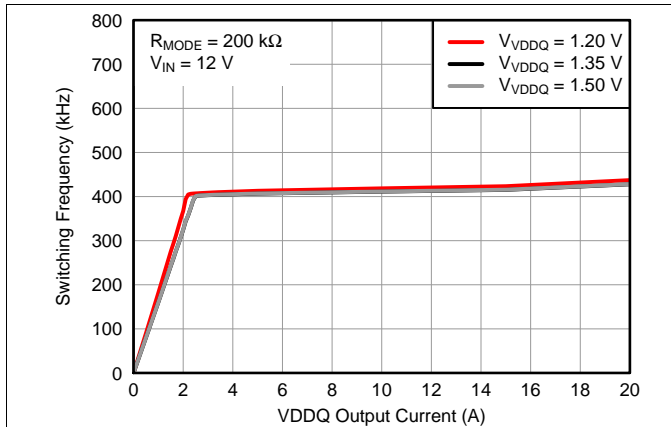

Figure 13. Switching Frequency vs Load Current

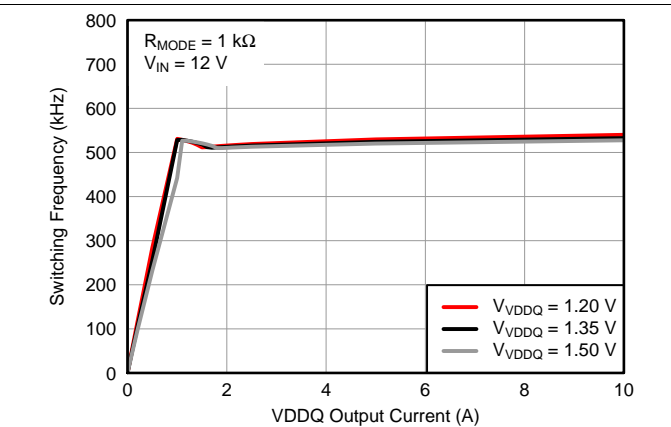

Figure 14. Switching Frequency vs Load Current

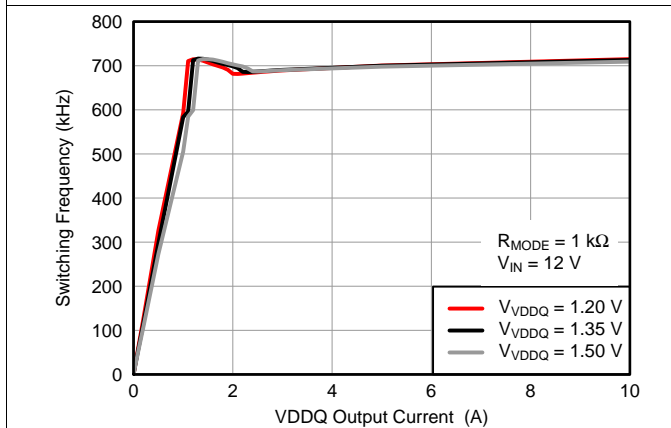

Figure 15. Switching Frequency vs Load Current

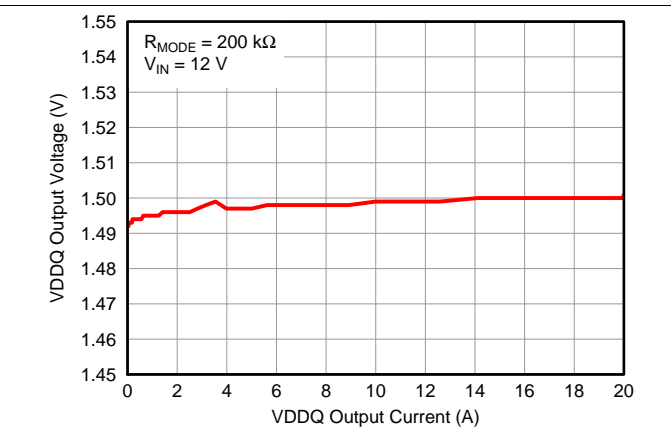

Figure 16. Load Regulation

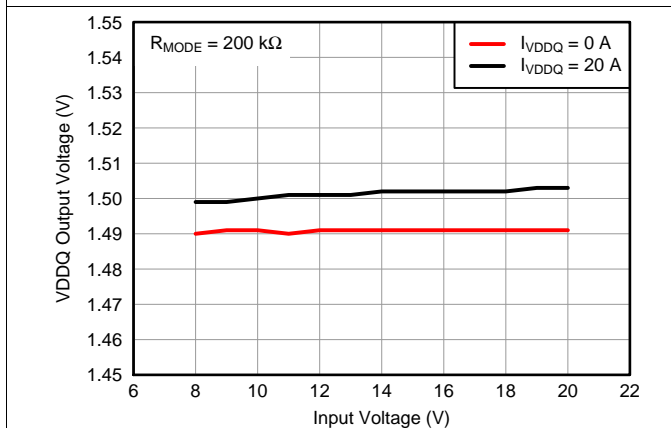

Figure 17. Line Regulation

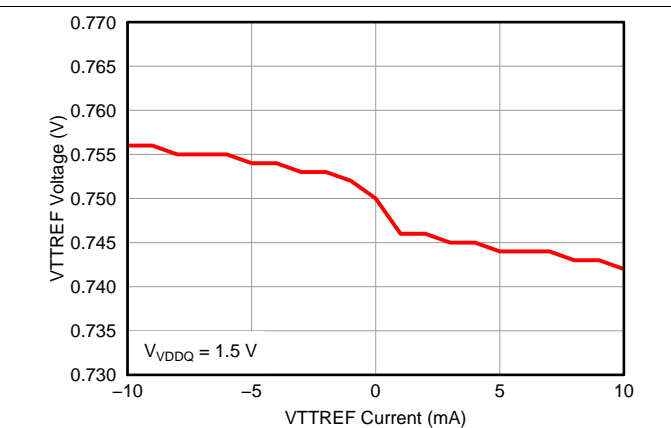

Figure 18. VTTREF Load Regulation

Typical Characteristics (continued)

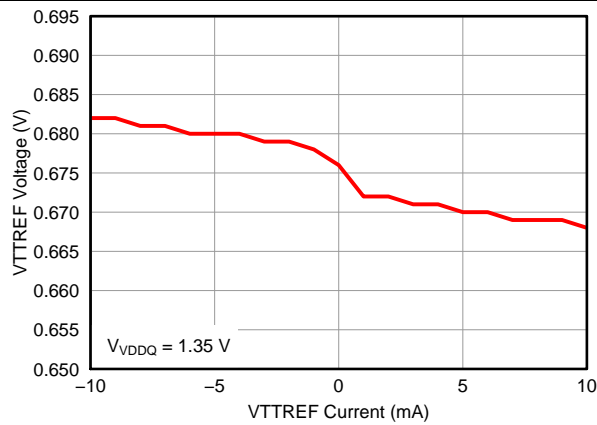

Figure 19. VTTREF Load Regulation

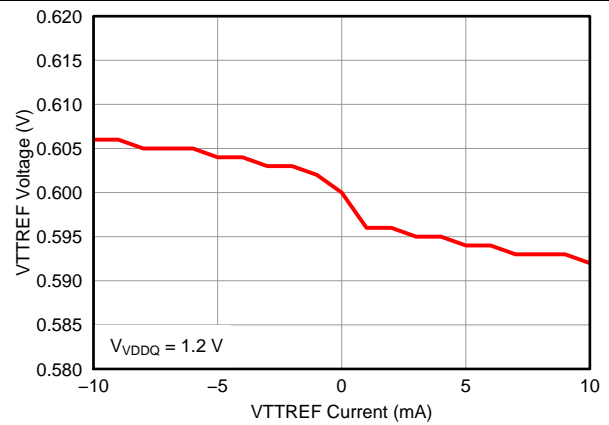

Figure 20. VTTREF Load Regulation

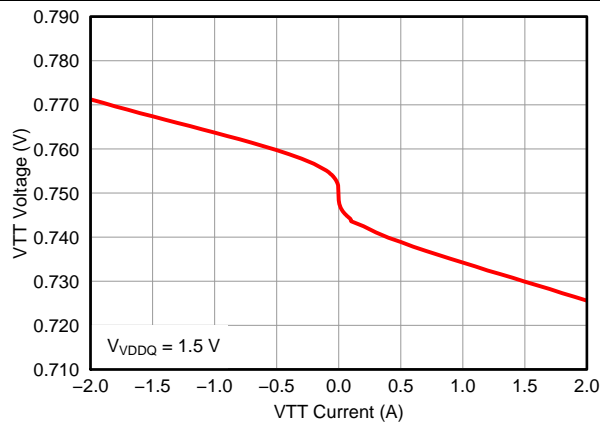

Figure 21. VTT Load Regulation

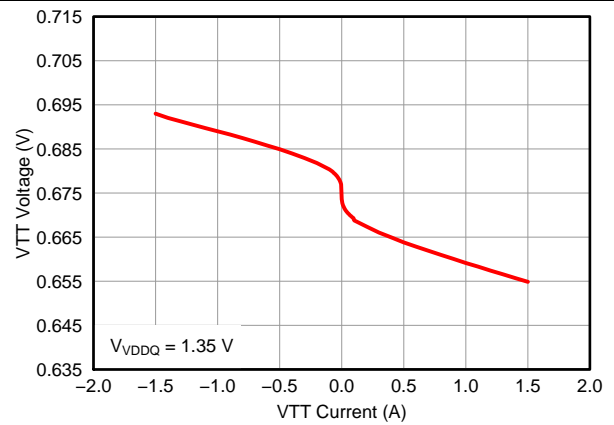

Figure 22. VTT Load Regulation

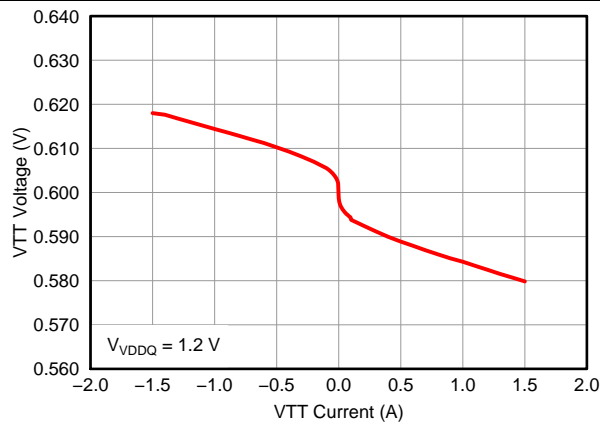

Figure 23. VTT Load Regulation

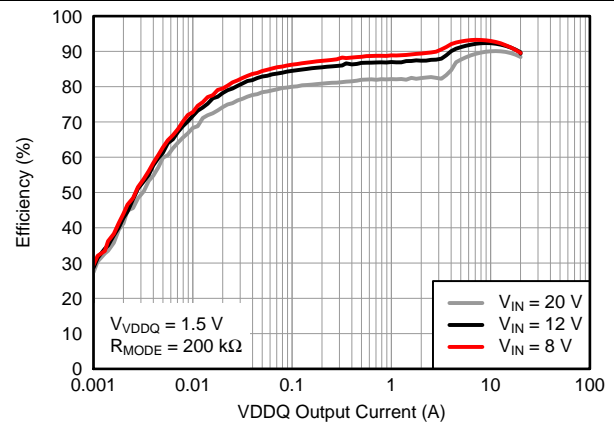
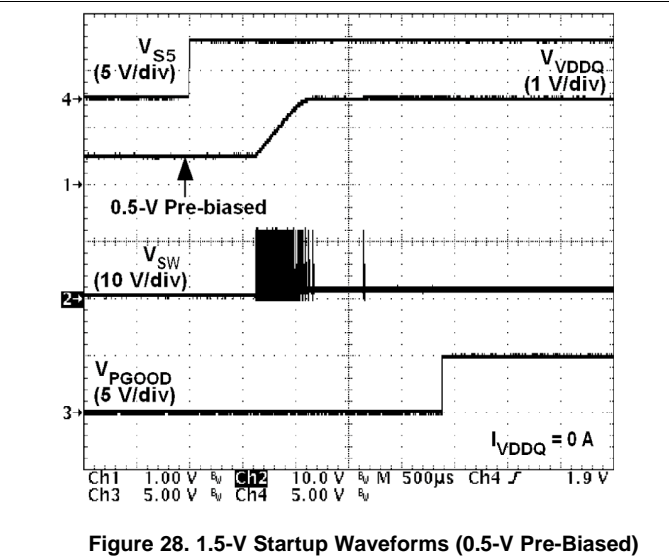
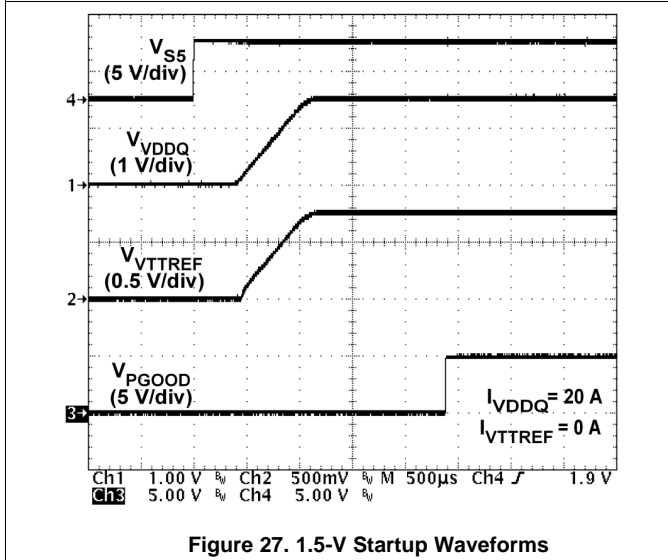
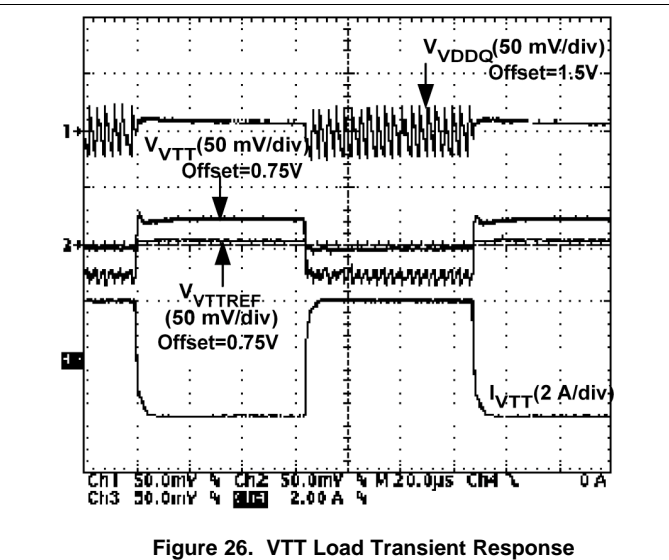
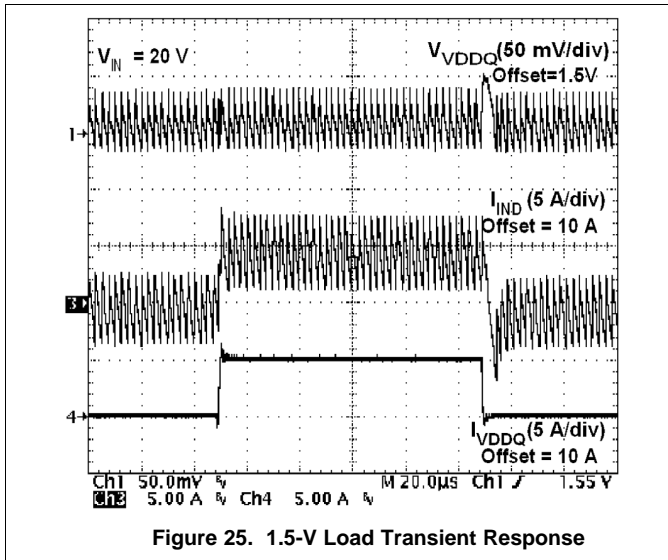

Figure 24. Efficiency

Typical Characteristics (continued)



Typical Characteristics (continued)

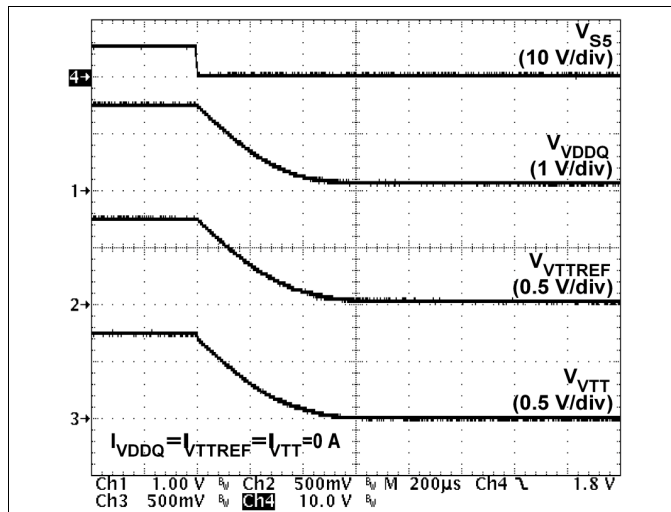

Figure 29. 1.5-V Soft-Stop Waveforms (Tracking Discharge)

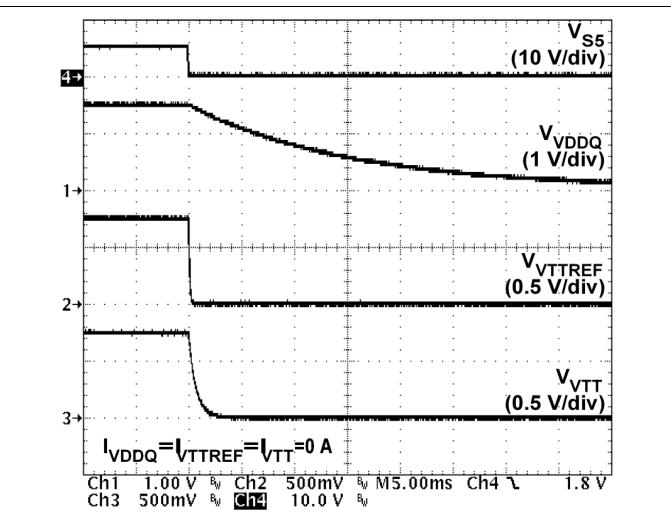

Figure 30. 1.5-V Soft-Stop Waveforms (Non-Tracking Discharge)

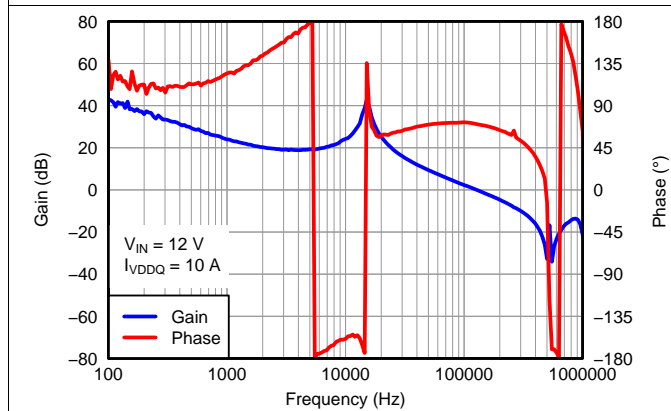

Figure 31. VDDQ Bode Plot

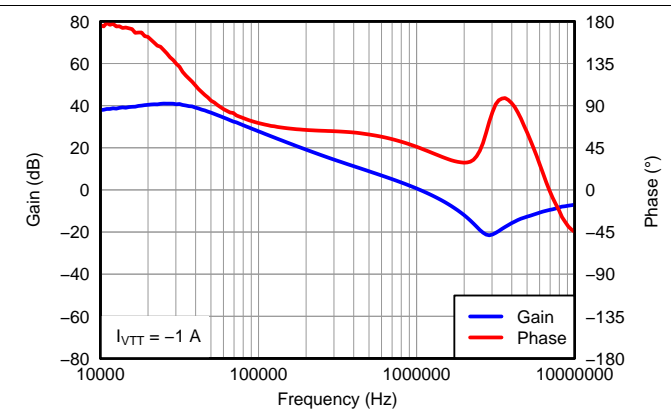

Figure 32. VTT Bode Plot (Sink)

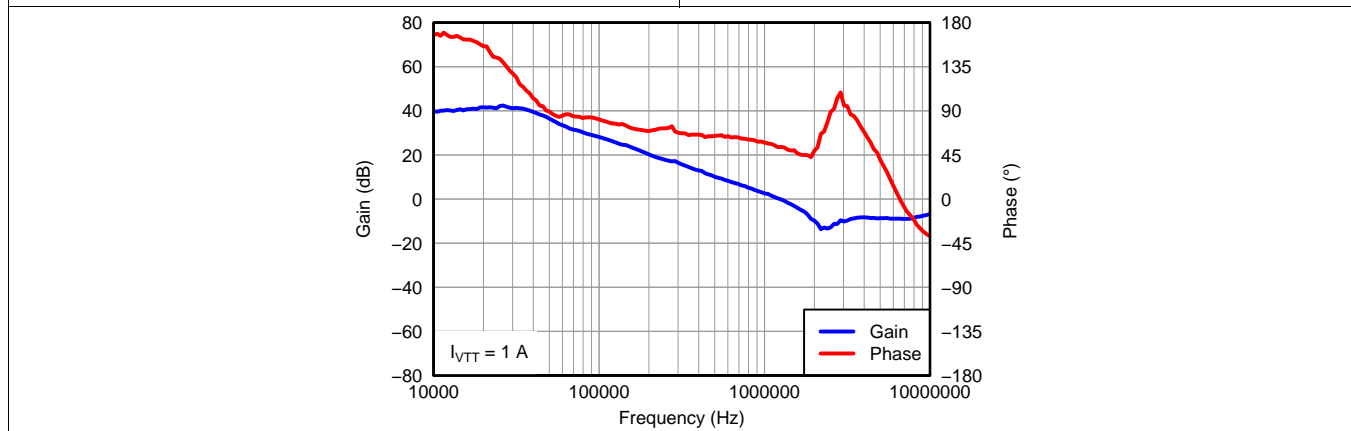
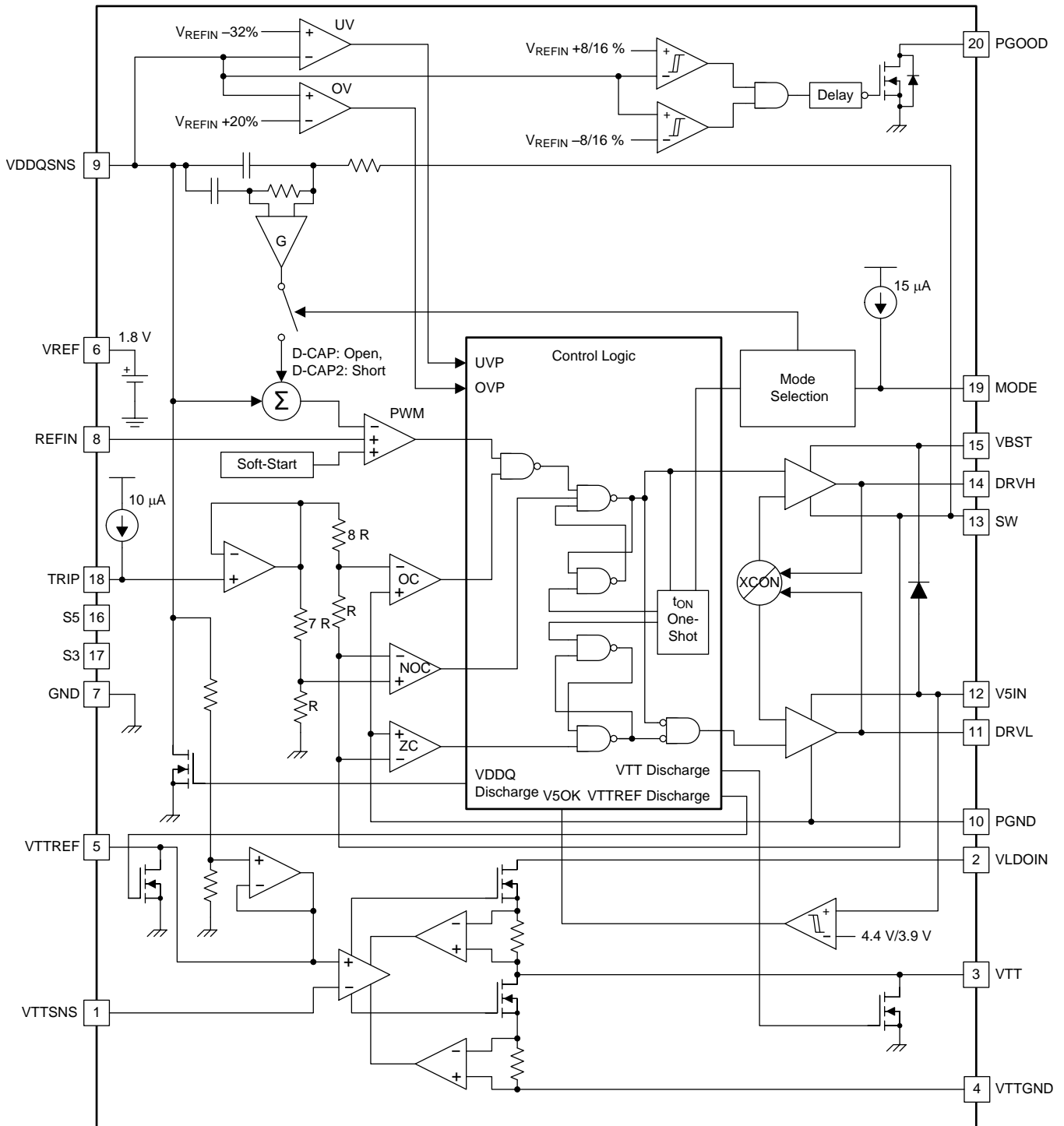

Figure 33. VTT Bode Plot (Source)

7 Detailed Description

7.1 Overview

7.2 Functional Block Diagram



Copyright © 2016, Texas Instruments Incorporated

7.3 Feature Description

7.3.1 VDDQ Switch Mode Power Supply Control

The TPS51916 device supports two SMPS control architectures, D-CAP™ mode and D-CAP2™ mode. Both control modes do not require complex external compensation networks and are suitable for designs with small external components counts. The D-CAP™ mode provides fast transient response with appropriate amount of equivalent series resistance (ESR) on the output capacitors. The D-CAP2™ mode is dedicated for a configuration with very low ESR output capacitors such as multi-layer ceramic capacitors (MLCC). For the both modes, an adaptive on-time control scheme is used to achieve pseudo-constant frequency. The TPS51916 device adjusts the on-time (t_{ON}) to be inversely proportional to the input voltage (V_{IN}) and proportional to the output voltage (V_{VDDQ}). This makes a switching frequency fairly constant over the variation of input voltage at the steady state condition. These control modes and switching frequencies are selected by the MODE pin described in [Table 2](#).

7.3.2 VREF and REFIN, VDDQ Output Voltage

The part provides a 1.8-V, $\pm 0.8\%$ accurate, voltage reference from VREF. This output has a 300- μ A (max) current capability to drive the REFIN input voltage through a voltage divider circuit. A capacitor with a value of 0.1- μ F or larger should be attached close to the VREF terminal.

The VDDQ switch-mode power supply (SMPS) output voltage is defined by REFIN voltage, within the range between 0.7 V and 1.8 V, programmed by the resistor-divider connected between VREF and GND. (See section.) A few nano farads of capacitance from REFIN to GND is recommended for stable operation.

7.3.3 Soft-Start and Powergood

Provide a voltage supply to VIN and V5IN before asserting S5 to high. TPS51916 device provides integrated VDDQ soft-start functions to suppress in-rush current at start-up. The soft-start is achieved by controlling internal reference voltage ramping up. [Figure 34](#) shows the start-up waveforms. The switching regulator waits for 400 μ s after S5 assertion. The MODE pin voltage is read in this period. A typical VDDQ ramp up duration is 700 μ s.

TPS51916 device has a powergood open-drain output that indicates the VDDQ voltage is within the target range. The target voltage window and transition delay times of the PGOOD comparator are $\pm 8\%$ (typ) and 1-ms delay for assertion (low to high), and $\pm 16\%$ (typ) and 330-ns delay for de-assertion (high to low) during running. The PGOOD start-up delay is 2.5 ms after S5 is asserted to high. Note that the time constant which is composed of the REFIN capacitor and a resistor divider needs to be short enough to reach the target value before PGOOD comparator enabled.

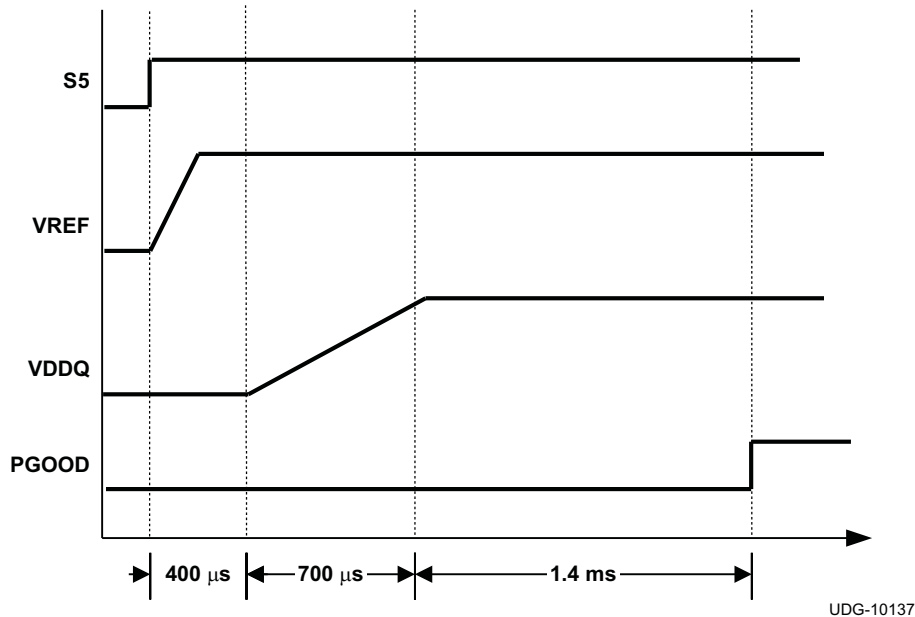

Figure 34. Typical Start-up Waveforms

Feature Description (continued)

7.3.4 Power State Control

The TPS51916 device has two input pins, S3 and S5, to provide simple control scheme of power state. All of VDDQ, VTTREF and VTT are turned on at S0 state (S3=S5=high). In S3 state (S3=low, S5=high), VDDQ and VTTREF voltages are kept on while VTT is turned off and left at high impedance state (high-Z). The VTT output floats and does not sink or source current in this state. In S4/S5 states (S3=S5=low), all of the three outputs are turned off and discharged to GND according to the discharge mode selected by MODE pin. Each state code represents as follow; S0 = full ON, S3 = suspend to RAM (STR), S4 = suspend to disk (STD), S5 = soft OFF. (See [Table 1](#))

Table 1. S3 or S5 Power State Control

STATE	S3	S5	VREF	VDDQ	VTTREF	VTT
S0	HI	HI	ON	ON	ON	ON
S3	LO	HI	ON	ON	ON	OFF(High-Z)
S4/S5	LO	LO	OFF	OFF(Discharge)	OFF(Discharge)	OFF(Discharge)

7.3.5 Discharge Control

In S4/S5 state, VDDQ, VTT, and VTTREF outputs are discharged based on the respective discharge mode selected above. The tracking discharge mode discharges VDDQ output through the internal VTT regulator transistors enabling quick discharge operation. The VTT output maintains tracking of the VTTREF voltage in this mode. (Please refer to [Figure 29](#)) After 4 ms of tracking discharge operation, the mode changes to non-tracking discharge. The VDDQ output must be connected to the VLDOIN pin in this mode. The non-tracking mode discharges the VDDQ and VTT pins using internal MOSFETs that are connected to corresponding output terminals. The non-tracking discharge is slow compared with the tracking discharge due to the lower current capability of these MOSFETs. (Please refer to [Figure 30](#))

7.3.6 VTT and VTTREF

The TPS51916 device integrates two high-performance, low-drop-out linear regulators, VTT and VTTREF, to provide complete DDR2, DDR3, DDR3L, and DDR4 power solutions. The VTTREF has a 10-mA sink/source current capability, and tracks $\frac{1}{2}$ of VDDQSNS with $\pm 1\%$ accuracy using an on-chip $\frac{1}{2}$ divider. A 0.22- μF (or larger) ceramic capacitor must be connected close to the VTTREF terminal to ensure stable operation. The VTT responds quickly to track VTTREF within ± 40 mV at all conditions, and the current capability is 2 A for both sink and source. A 10- μF (or larger) ceramic capacitor(s) need to be connected close to the VTT terminal for stable operation. To achieve tight regulation with minimum effect of wiring resistance, a remote sensing terminal, VTTSNS, should be connected to the positive node of VTT output capacitors as a separate trace from the high-current line to the VTT pin. (Refer to the [Layout](#) section for details.)

When VTT is not required in the design, following treatment is strongly recommended.

- Connect VLDOIN to VDDQ.
- Tie VTTSNS to VTT, and remove capacitors from VTT to float.
- Connect VTTGND to GND.
- Select MODE2, 3, 4 or 5 shown in [Table 2](#) (Select Non-tracking discharge mode).
- Maintain a 0.22- μF capacitor connected at VTTREF.
- Pull down S3 to GND with 1-k Ω resistance.

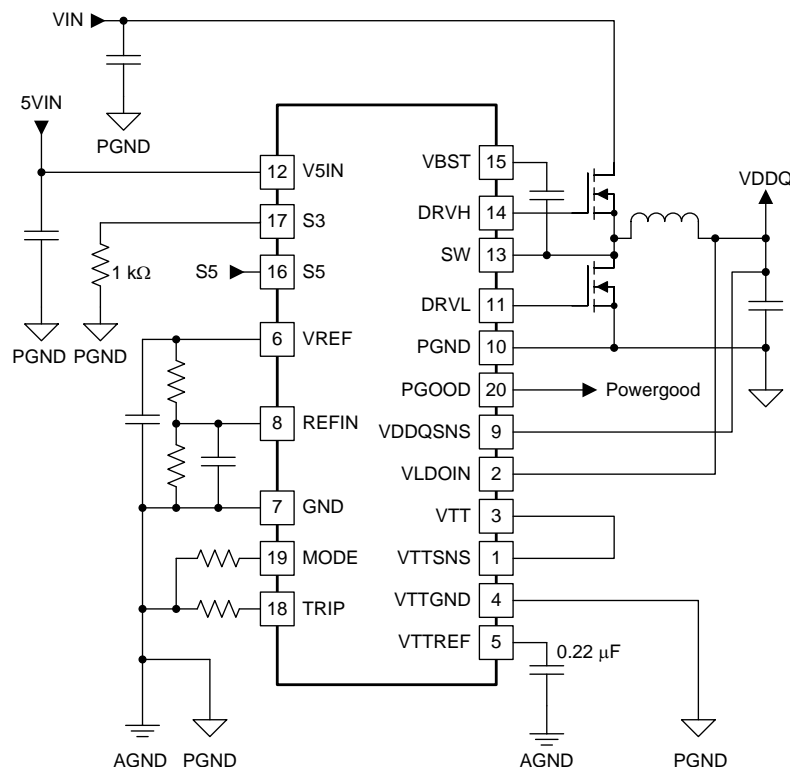

Copyright © 2016, Texas Instruments Incorporated

Figure 35. Application Circuit When VTT Is Not Required

7.3.7 VDDQ Overvoltage and Undervoltage Protection

The TPS51916 sets the overvoltage protection (OVP) when VDDQSNS voltage reaches a level 20% (typ) higher than the REFIN voltage. When an OV event is detected, the controller changes the output target voltage to 0 V. This usually turns off DRVH and forces DRVL to be on. When the inductor current begins to flow through the low-side MOSFET and reaches the negative OCL, DRVL is turned off and DRVH is turned on, for a minimum on-time.

After the minimum on-time expires, DRVH is turned off and DRVL is turned on again. This action minimizes the output node undershoot due to LC resonance. When the VDDQSNS reaches 0 V, the driver output is latched as DRVH off, DRVL on. VTTREF and VTT are turned off and discharged using the non-tracking discharge MOSFETs regardless of the tracking mode.

The undervoltage protection (UVP) latch is set when the VDDQSNS voltage remains lower than 68% (typ) of the REFIN voltage for 1 ms or longer. In this fault condition, the controller latches DRVH low and DRVL low and discharges the VDDQ, VTT and VTTREF outputs. UVP detection function is enabled after 1.2 ms of SMPS operation to ensure startup.

To release the OVP and UVP latches, toggle S5 or adjust the V5IN voltage down and up beyond the undervoltage lockout threshold.

7.3.8 VDDQ Out-of-Bound Operation

When the output voltage rises to 8% above the target value, the out-of-bound operation starts. During the out-of-bound condition, the controller operates in forced PWM-only mode. Turning on the low-side MOSFET beyond the zero inductor current quickly discharges the output capacitor. During this operation, the cycle-by-cycle negative overcurrent limit is also valid. Once the output voltage returns to within regulation range, the controller resumes to auto-skip mode.

7.3.9 VDDQ Overcurrent Protection

The VDDQ SMPS has cycle-by-cycle overcurrent limiting protection. The inductor current is monitored during the off-state using the low-side MOSFET $R_{DS(on)}$, and the controller maintains the off-state when the inductor current is larger than the overcurrent trip level. The current monitor circuit inputs are PGND and SW pins so that those should be properly connected to the source and drain terminals of low-side MOSFET. The overcurrent trip level, V_{OCTRIP} , is determined by Equation 1, where R_{TRIP} is the value of the resistor connected between the TRIP pin and GND, and I_{TRIP} is the current sourced from the TRIP pin. I_{TRIP} is 10 μ A typically at room temperature, and has 4700ppm/ $^{\circ}$ C temperature coefficient to compensate the temperature dependency of the low-side MOSFET $R_{DS(on)}$.

$$V_{OCTRIP} = R_{TRIP} \times \frac{I_{TRIP}}{8} \quad (1)$$

Because the comparison is done during the off-state, V_{OCTRIP} sets the valley level of the inductor current. The load current OCL level, I_{OCL} , can be calculated by considering the inductor ripple current as shown in Equation 2.

$$I_{OCL} = \left(\frac{V_{OCTRIP}}{R_{DS(on)}} \right) + \frac{I_{IND(ripple)}}{2} = \left(\frac{V_{OCTRIP}}{R_{DS(on)}} \right) + \frac{1}{2} \times \frac{V_{IN} - V_{OUT}}{L_X} \times \frac{V_{OUT}}{f_{SW} \times V_{IN}}$$

where

- $I_{IND(ripple)}$ is inductor ripple current (2)

In an overcurrent condition, the current to the load exceeds the current to the output capacitor, thus the output voltage tends to fall down. Eventually, it crosses the undervoltage protection threshold and shuts down.

7.3.10 VTT Overcurrent Protection

The LDO has an internally fixed constant overcurrent limiting of 3-A (typ) for both sink and source operation.

7.3.11 V5IN Undervoltage Lockout Protection

The TPS51916 has a 5-V supply undervoltage lockout protection (UVLO) threshold. When the V5IN voltage is lower than UVLO threshold voltage, typically 3.9 V, VDDQ, VTT and VTTREF are shut off. This is a non-latch protection.

7.3.12 Thermal Shutdown

The TPS51916 includes an internal temperature monitor. If the temperature exceeds the threshold value, 140 $^{\circ}$ C (typ), VDDQ, VTT and VTTREF are shut off. The state of VDDQ is open, and that of VTT and VTTREF are high impedance (high-Z) at thermal shutdown. The discharge functions of all outputs are disabled. This is a non-latch protection and the operation is restarted with soft-start sequence when the device temperature is reduced by 10 $^{\circ}$ C (typ).

$$f_0 = \frac{1}{2\pi \times \text{ESR} \times C_{\text{OUT}}} \leq \frac{f_{\text{SW}}}{3}$$

where

- ESR is the effective series resistance of the output capacitor
- C_{OUT} is the capacitance of the output capacitor
- f_{sw} is switching frequency

(3)

Jitter is another attribute caused by signal-to-noise ratio of the feedback signal. One of the major factors that determine jitter performance in D-CAP™ mode is the down-slope angle of the VDDQSNS ripple voltage. Figure 37 shows, in the same noise condition, that jitter is improved by making the slope angle larger.

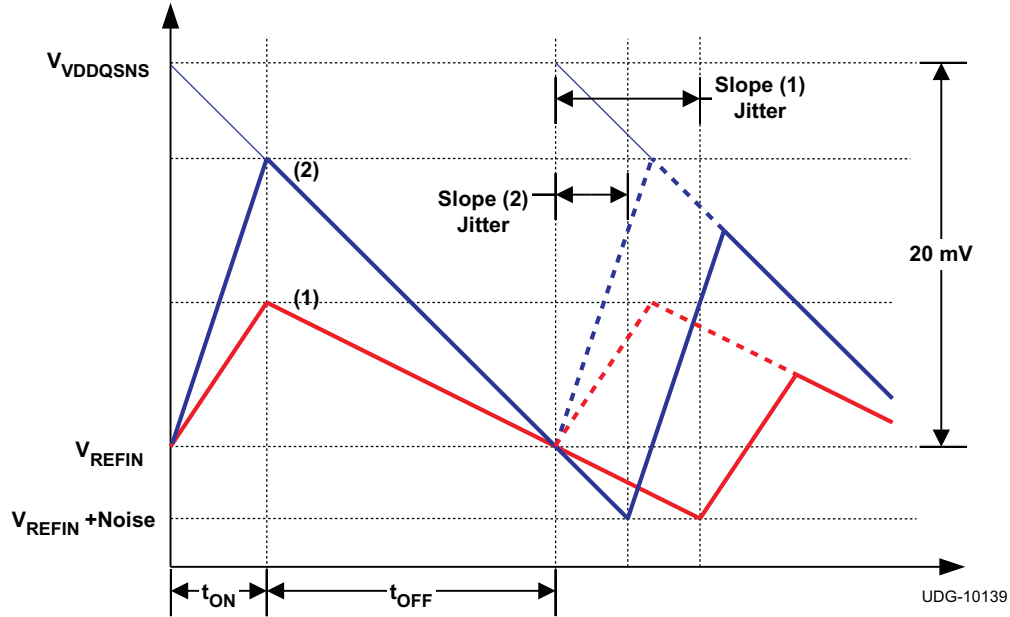

Figure 37. Ripple Voltage Slope and Jitter Performance

For a good jitter performance, use the recommended down slope of approximately 20 mV per switching period as shown in Figure 37 and Equation 4.

$$\frac{V_{\text{OUT}} \times \text{ESR}}{f_{\text{SW}} \times L_X} \geq 20\text{mV}$$

where

- V_{OUT} is the VDDQ output voltage
- L_X is the inductance

(4)

7.5 D-CAP2™ Mode Operation

Figure 38 shows simplified model of D-CAP2™ architecture.

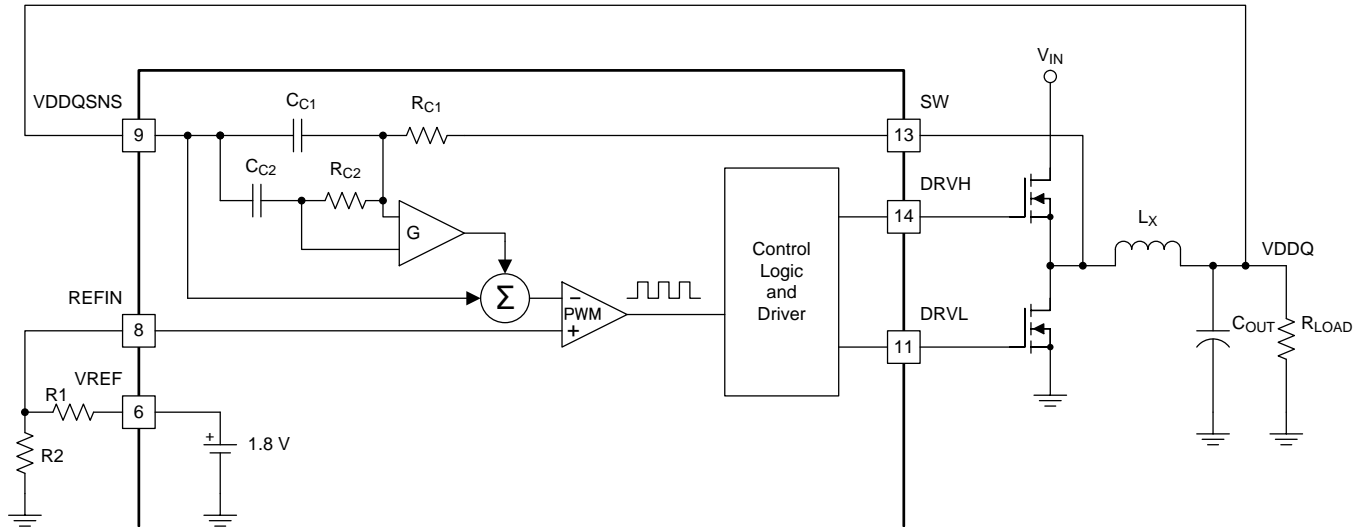

Figure 38. Simplified Modulator Using D-CAP2™ Mode

The D-CAP2™ mode in the TPS51916 device includes an internal feedback network enabling the use of very low ESR output capacitor(s) such as multi-layer ceramic capacitors. The role of the internal network is to sense the ripple component of the inductor current information and combine it with voltage feedback signal. Using $R_{C1}=R_{C2}\equiv R_C$ and $C_{C1}=C_{C2}\equiv C_C$, 0-dB frequency of the D-CAP2™ mode is given by Equation 5. It is recommended that the 0-dB frequency (f_0) be lower than 1/3 of the switching frequency to secure the proper phase margin

$$f_0 = \frac{R_C \times C_C}{2\pi \times G \times L_X \times C_{OUT}} \leq \frac{f_{SW}}{3}$$

where

- G is gain of the amplifier which amplifies the ripple current information generated by the compensation circuit (5)

The typical G value is 0.25, and typical $R_C C_C$ time constant values for 500 kHz and 670 kHz operation are 23 μ s and 14.6 μ s, respectively.

For example, when $f_{SW}=500$ kHz and $L_X=1$ μ H, C_{OUT} should be larger than 88 μ F.

When selecting the capacitor, pay attention to its characteristics. For MLCC use X5R or better dielectric and consider the derating of the capacitance by both DC bias and AC bias. When derating by DC bias and AC bias are 80% and 50%, respectively, the effective derating is 40% because $0.8 \times 0.5 = 0.4$. The capacitance of specialty polymer capacitors may change depending on the operating frequency. Consult capacitor manufacturers for specific characteristics.

8 Application and Implementation

NOTE

Information in the following applications sections is not part of the TI component specification, and TI does not warrant its accuracy or completeness. TI's customers are responsible for determining suitability of components for their purposes. Customers should validate and test their design implementation to confirm system functionality.

8.1 Application Information

8.1.1 DDR3, D-CAP™ 400-kHz Application with Tracking Discharge

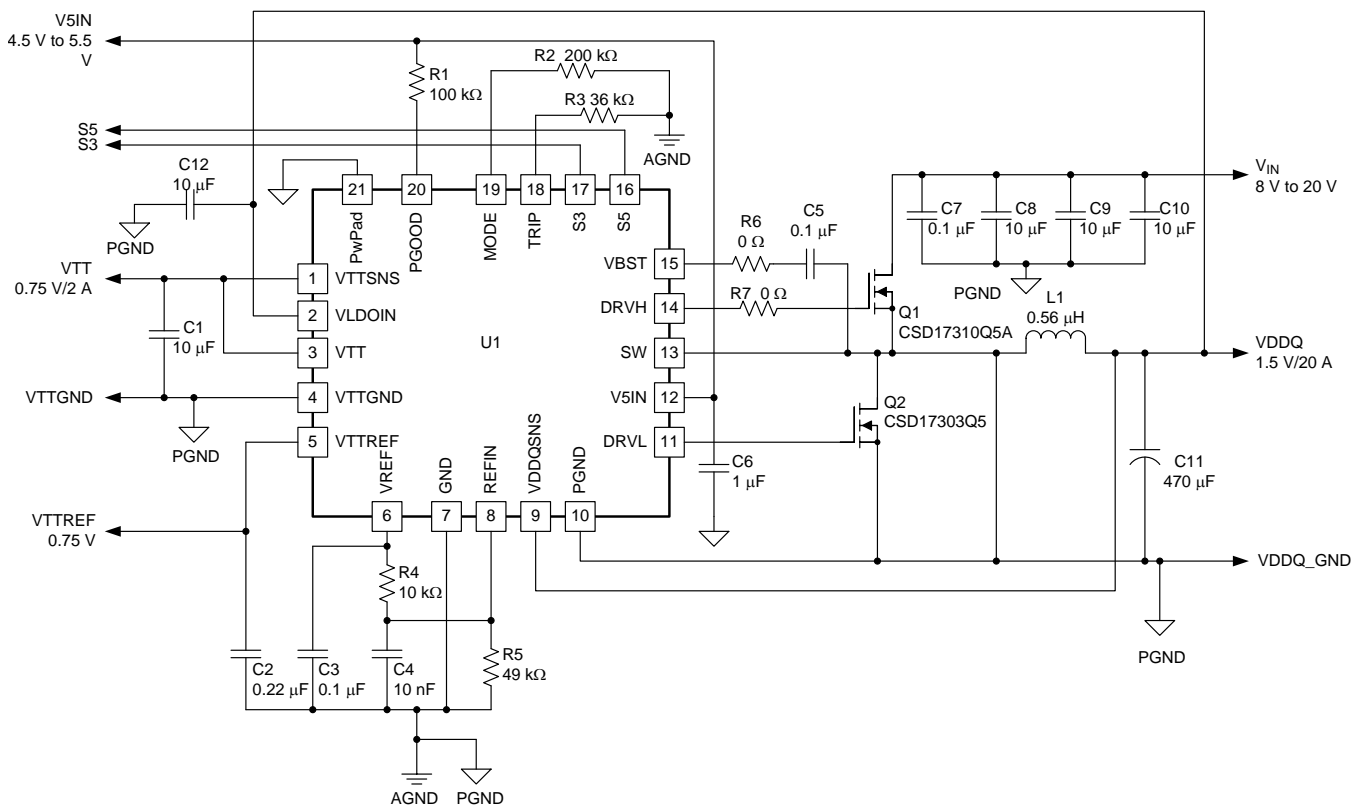

Copyright © 2016, Texas Instruments Incorporated

Figure 39. DDR3, D-CAP™ 400-kHz Application Circuit, Tracking Discharge

8.1.1.1 Design Requirements

Table 3. Design Requirements

PARAMETER		TEST CONDITIONS	MIN	TYP	MAX	UNIT
V_{IN}	Input voltage		8	12	20	V
V_{V5IN}	V5IN voltage		4.5	5	5.5	V
V_{VDDQ}	VDDQ output voltage			1.5		V
I_{VDDQ}	VDDQ output current		0		20	A
V_{VTT}	VTT output voltage			0.75		V
I_{VTT}	VTT output current	DDR3 mode , $V_{VTT} = 0.75$ V	-2		2	A
f_{SW}	Switching frequency	DCAP mode		400		kHz

8.1.1.2 Detailed Design Procedure

The external components selection is simple in D-CAP™ mode.

8.1.1.2.1 1. Determine the value of R1 AND R2

The output voltage is determined by the value of the voltage-divider resistor, R1 and R2 as shown in [Figure 36](#). R1 is connected between VREF and REFIN pins, and R2 is connected between the REFIN pin and GND. Setting R1 as 10-kΩ is a good starting point. Determine R2 using [Equation 6](#).

$$R2 = \frac{R1}{\left(\frac{1.8}{V_{OUT} - \left(\frac{I_{IND(ripple)} \times ESR}{2} \right)} \right) - 1} \quad (6)$$

8.1.1.2.2 2. Choose the inductor

The inductance value should be determined to yield a ripple current of approximately ¼ to ½ of maximum output current. Larger ripple current increases output ripple voltage and improves the signal-to-noise ratio and helps stable operation.

$$L_X = \frac{1}{I_{IND(ripple)} \times f_{SW}} \times \frac{(V_{IN(max)} - V_{OUT}) \times V_{OUT}}{V_{IN(max)}} = \frac{3}{I_{O(max)} \times f_{SW}} \times \frac{(V_{IN(max)} - V_{OUT}) \times V_{OUT}}{V_{IN(max)}} \quad (7)$$

The inductor needs a low direct current resistance (DCR) to achieve good efficiency, as well as enough room above peak inductor current before saturation. The peak inductor current can be estimated in [Equation 8](#).

$$I_{IND(peak)} = \frac{R_{TRIP} \times I_{TRIP}}{8 \times R_{DS(on)}} + \frac{1}{L \times f_{SW}} \times \frac{(V_{IN(max)} - V_{OUT}) \times V_{OUT}}{V_{IN(max)}} \quad (8)$$

8.1.1.2.3 3. Choose the OCL setting resistance, R_{TRIP}

Combining [Equation 1](#) and [Equation 2](#), R_{TRIP} can be obtained using [Equation 9](#).

$$R_{TRIP} = \frac{8 \times \left(I_{OCL} - \left(\frac{(V_{IN} - V_{OUT})}{(2 \times L_X)} \right) \times \frac{V_{OUT}}{(f_{SW} \times V_{IN})} \right) \times R_{DS(on)}}{I_{TRIP}} \quad (9)$$

8.1.1.2.4 Choose the output capacitors

Organic semiconductor capacitor(s) or specialty polymer capacitor(s) are recommended. Determine ESR to meet small signal stability and recommended ripple voltage. A quick reference is shown in [Equation 10](#) and [Equation 11](#).

$$\frac{1}{2\pi \times ESR \times C_{OUT}} \leq \frac{f_{SW}}{3} \quad (10)$$

$$\frac{V_{OUT} \times ESR}{f_{SW} \times L_X} \geq 20\text{mV} \quad (11)$$

Table 4. DDR3, D-CAP™ 400-kHz Application Circuit, List of Materials

REFERENCE DESIGNATOR	QTY	SPECIFICATION	MANUFACTURE	PART NUMBER
C8, C9, C10	3	10 μ F, 25 V	Taiyo Yuden	TMK325BJ106MM
C11	1	470 μ F, 2 V, 6 m Ω	Panasonic	EEFSE0D471R
L1	1	0.56 μ H, 21 A, 1.56 m Ω	Panasonic	ETQP4LR56WFC
Q1	1	30 V, 21 A, 4.5 m Ω	Texas Instruments	CSD17310Q5A
Q2	1	30 V, 32 A, 2 m Ω	Texas Instruments	CSD17303Q5

8.1.1.3 Application Curves

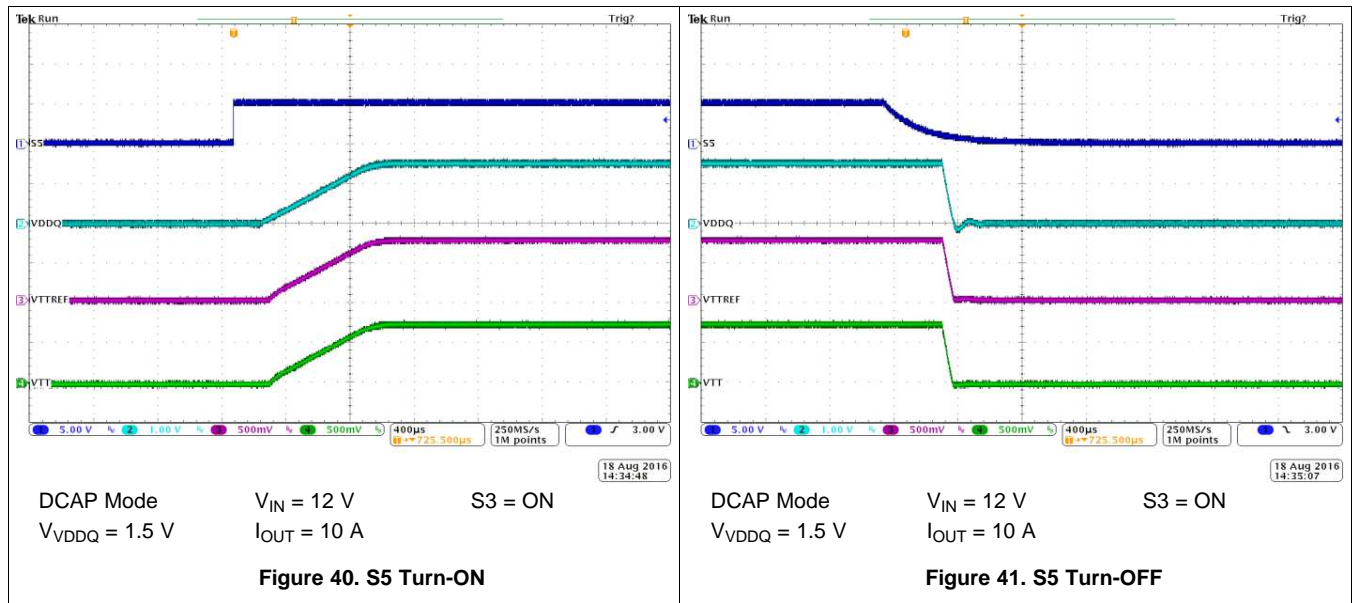

Figure 40. S5 Turn-ON

Figure 41. S5 Turn-OFF

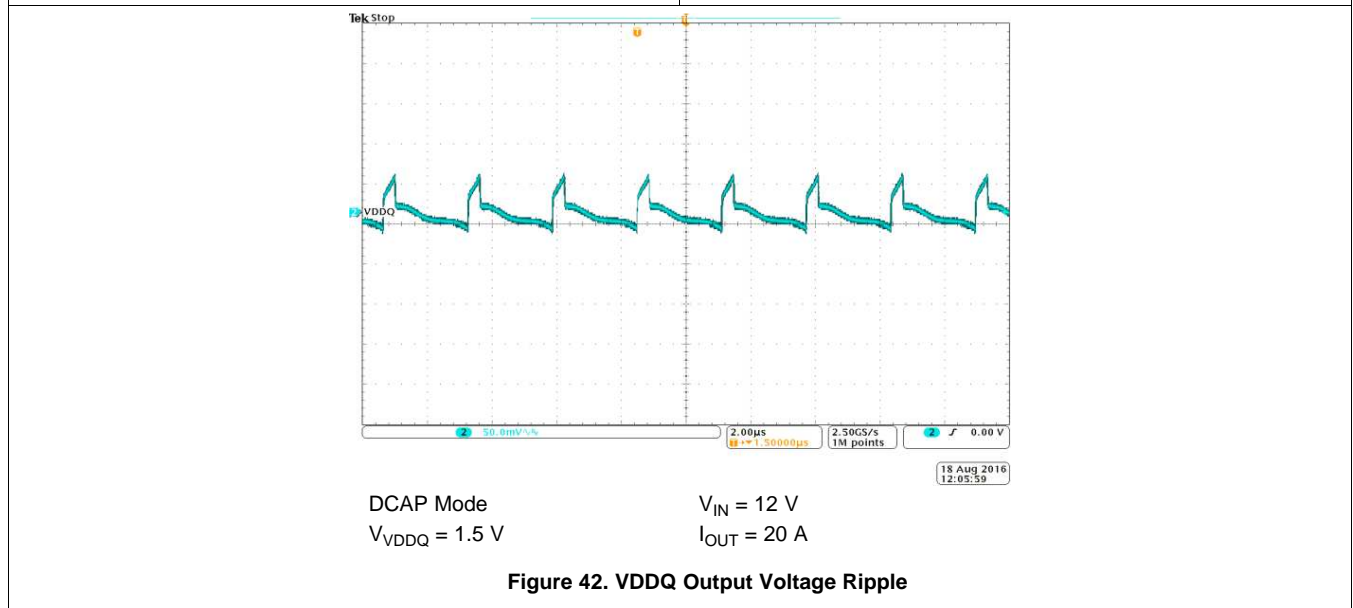
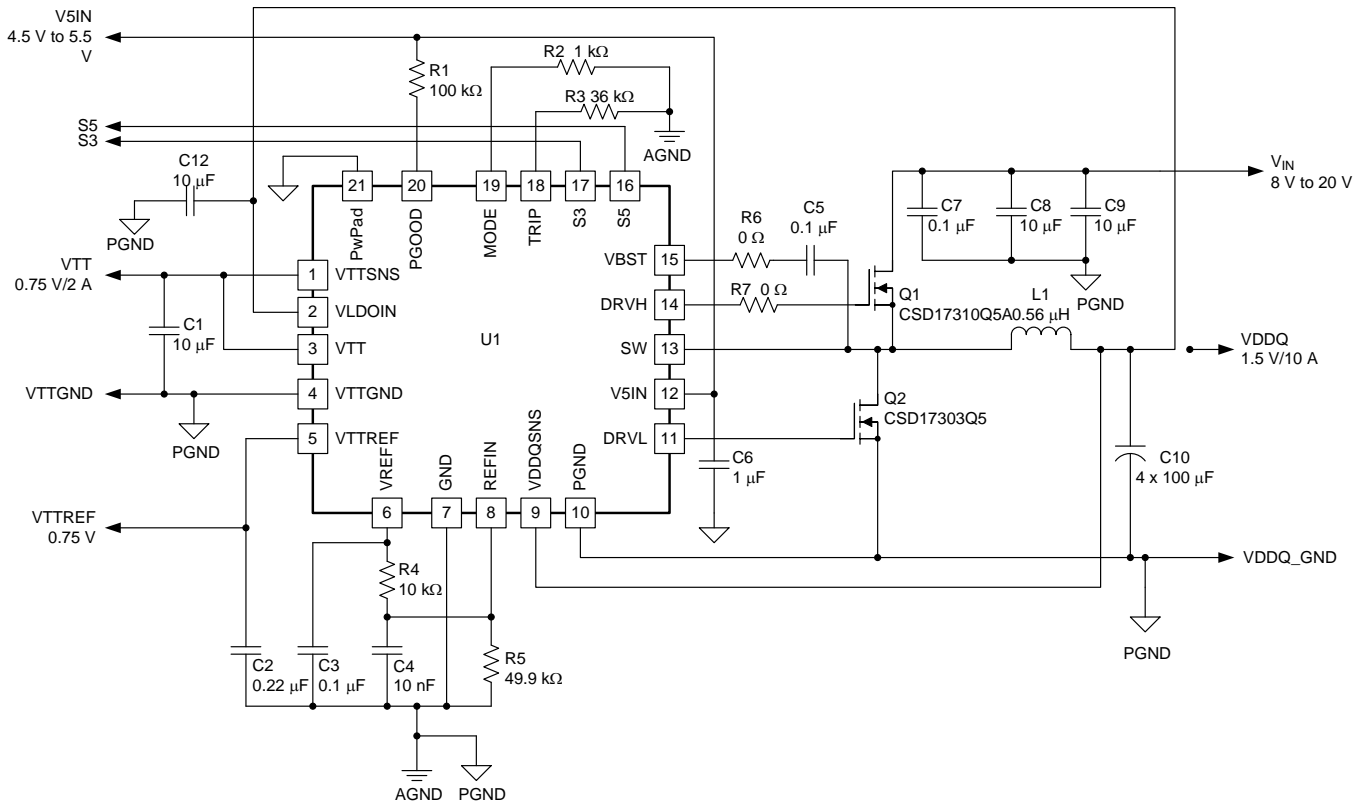

Figure 42. VDDQ Output Voltage Ripple

8.1.2 DDR3, DCAP-2 500-kHz Application, with Tracking Discharge



Copyright © 2016, Texas Instruments Incorporated

Figure 43. DDR3, DCAP-2 500-kHz Application Circuit, Tracking Discharge

Table 5. DDR3, DCAP-2 500-kHz Application Circuit, List of Materials

REFERENCE DESIGNATOR	QTY	SPECIFICATION	MANUFACTURE	PART NUMBER
C8, C9	2	10 µF, 25 V	Taiyo Yuden	TMK325BJ106MM
C10	4	100 µF, 6.3 V	Murata	GRM32ER60J107ME20L
L1	1	0.56 µH, 21 A, 1.56 mΩ	Panasonic	ETQP4LR56WFC
Q1	1	30 V, 21 A, 4.5 mΩ	Texas Instruments	CSD17310Q5A
Q2	1	30 V, 32 A, 2 mΩ	Texas Instruments	CSD17303Q5

8.1.2.1 Design Requirements

Table 6. Design Requirements

PARAMETER		TEST CONDITIONS	MIN	TYP	MAX	UNIT
V _{IN}	Input voltage		8	12	20	V
V _{V5IN}	V5IN voltage		4.5	5	5.5	V
V _{VDDQ}	VDDQ output voltage			1.5		V
I _{VDDQ}	VDDQ output current		0		20	A
V _{VTT}	VTT output voltage			0.75		V
I _{VTT}	VTT output current	DDR3 mode , V _{VTT} = 0.75 V	-2		2	A
f _{SW}	Switching frequency	DCAP2 mode		500		kHz

8.1.2.2 Detailed Design Procedure

The design procedure for this design is very similar to the design procedure for the design described in the previous section (see [DDR3, D-CAP™ 400-kHz Application with Tracking Discharge](#)). The key differences in the design procedure is described here.

8.1.2.2.1 Select Mode and Switching Frequency

Select a value of 1 kΩ for the mode resistor to set the controller at DCAP2 mode with a switching frequency of 500-kHz.

8.1.2.2.2 Determine output capacitance

Determine output capacitance to meet small signal stability as shown in [Equation 12](#).

$$\frac{R_C \times C_C}{2\pi \times G \times L_X \times C_{OUT}} \leq \frac{f_{SW}}{3}$$

where

- $R_C \times C_C$ time constant is 23 μs for 500 kHz operation (or 14.6 μs for 670 kHz operation)
- $G = 0.25$

(12)

8.1.2.3 Application Curves

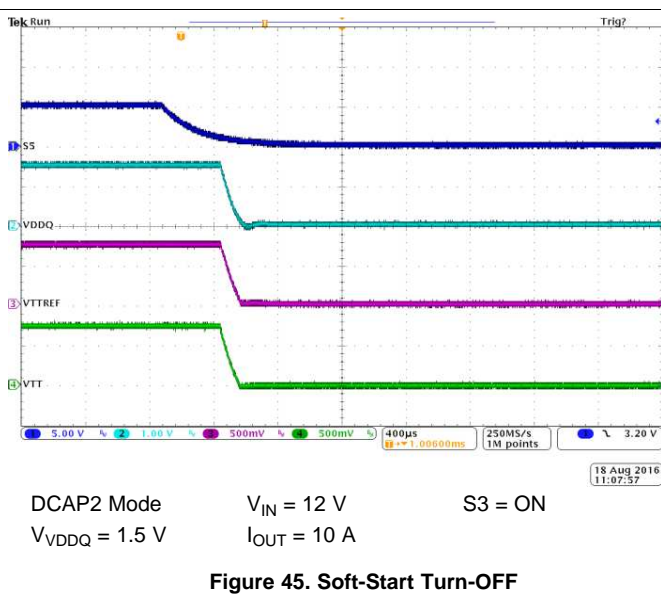
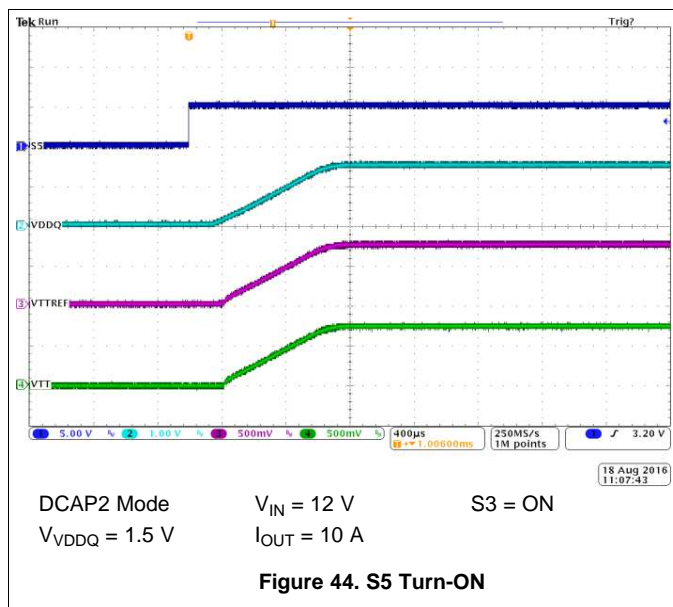

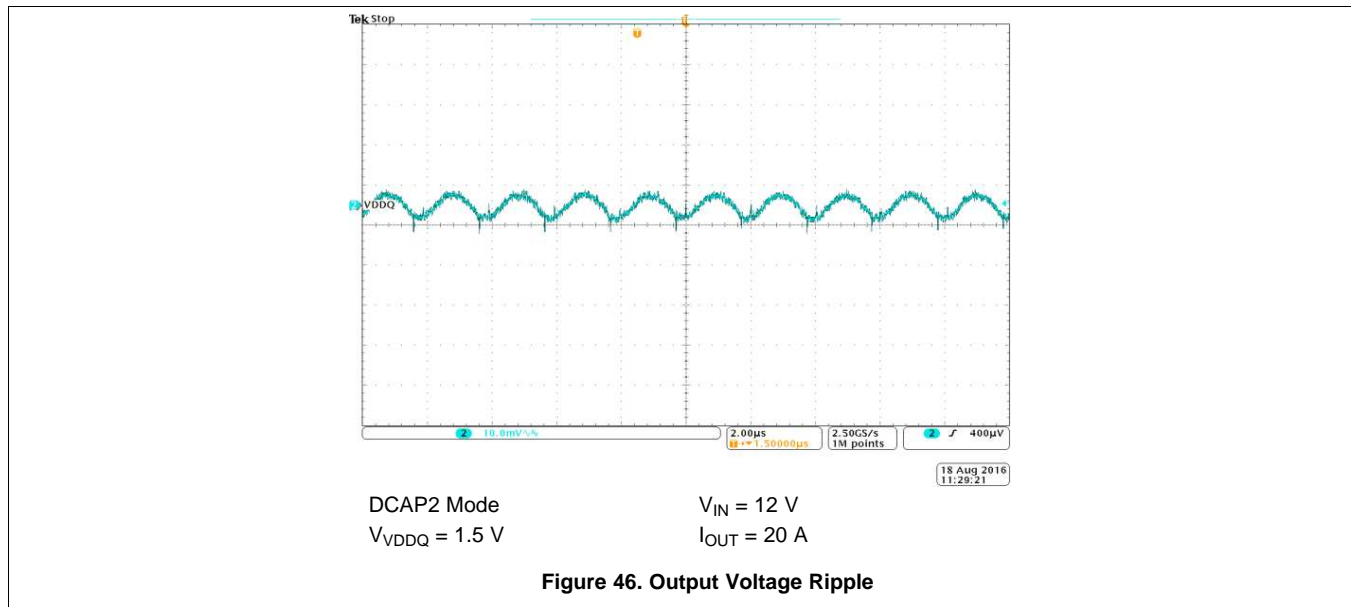

9 Power Supply Recommendations

The device is designed to operate from an input voltage supply between 3 V and 28 V. There are input voltage and switch node voltage limitations from the MOSFET. A separate 5-V power supply is required for the internal circuits and MOSFET gate drivers of the device.

10 Layout

10.1 Layout Guidelines

Certain issues must be considered before designing a layout using the TPS51916 device .

- V_{IN} capacitor(s), V_{OUT} capacitor(s) and MOSFETs are the power components and should be placed on one side of the PCB (solder side). Other small signal components should be placed on another side (component side). At least one inner system GND plane should be inserted, in order to shield and isolate the small signal traces from noisy power lines.
- All sensitive analog traces and components such as V_{DDQSNS} , V_{TTSNS} , MODE, REFIN, VREF and TRIP should be placed away from high-voltage switching nodes such as SW, DRVL, DRVH or VBST to avoid coupling. Use internal layer(s) as system GND plane(s) and shield feedback trace from power traces and components.
- The DC/DC converter has several high-current loops. The area of these loops should be minimized in order to suppress generating switching noise.
 - The most important loop to minimize the area of is the path from the V_{IN} capacitor(s) through the high and low-side MOSFETs, and back to the negative node of the V_{IN} capacitor(s). Connect the negative node of the V_{IN} capacitor(s) and the source of the low-side MOSFET as close as possible. (Refer to loop #1 of)
 - The second important loop is the path from the low-side MOSFET through inductor and V_{OUT} capacitor(s), and back to source of the low-side MOSFET. Connect the source of the low-side MOSFET and negative node of V_{OUT} capacitor(s) as close as possible. (Refer to loop #2 of)
 - The third important loop is of gate driving system for the low-side MOSFET. To turn on the low-side MOSFET, high current flows from V_{5IN} capacitor through gate driver and the low-side MOSFET, and back to negative node of the capacitor. To turn off the low-side MOSFET, high current flows from gate of the low-side MOSFET through the gate driver and PGND pin, and back to source of the low-side MOSFET. Connect negative node of V_{5IN} capacitor, source of the low-side MOSFET and PGND pin as close as possible. (Refer to loop #3 of [Figure 47](#))

Layout Guidelines (continued)

- Connect negative nodes of the VTTREF output capacitor, VREF capacitor and REFIN capacitor and bottom-side resistance of VREF voltage-divider to GND pin as close as possible. The negative node of the VTT output capacitor(s), VTTGND, GND and PGND pins should be connected to system GND plane near the device as shown in [Figure 48](#).
- Because the TPS51916 device controls output voltage referring to voltage across VOUT capacitor, VDDQSNS should be connected to the positive node of VOUT capacitor using different trace from that for VLDOIN. Remember that this sensing potential is the reference voltage of VTTREF. Avoid any noise generative lines. GND pin refers to the negative node of VOUT capacitor.
- Connect the overcurrent setting resistor from TRIP pin to GND pin and make the connections as close as possible to the device to avoid coupling from a high-voltage switching node.
- Connect the frequency and mode setting resistor from MODE pin to GND pin ground, and make the connections as close as possible to the device to avoid coupling from a high-voltage switching node.
- Connections from gate drivers to the respective gate of the high-side or the low-side MOSFET should be as short as possible to reduce stray inductance. Use 0.65 mm (25 mils) or wider trace and via(s) of at least 0.5 mm (20 mils) diameter along this trace.
- The PCB trace defined as SW node, which connects to the source of the high-side MOSFET, the drain of the low-side MOSFET and the high-voltage side of the inductor, should be as short and wide as possible.
- VLDOIN should be connected to VOUT with short and wide traces. An input bypass capacitor should be placed as close as possible to the pin with short and wide connections. The negative node of the capacitor should be connected to system GND plane.
- The output capacitor for VTT should be placed close to the pins with a short and wide connection in order to avoid additional ESR and/or ESL of the trace.
- VTTSNS should be connected to the positive node of the VTT output capacitor(s) using a separate trace from the high-current power line. When remote sensing is required attach the output capacitor(s) at that point. Also, it is recommended to minimize any additional ESR and/or ESL of ground trace between GND pin and the output capacitor(s).
- Consider adding a low pass filter (LPF) at VTTSNS in case the ESR of the VTT output capacitor(s) is larger than 2 m Ω .
- In order to effectively remove heat from the package, prepare a thermal land and solder to the package thermal pad. Wide trace of the component-side copper, connected to this thermal land, helps heat spreading. Numerous vias with a 0.3-mm diameter connected from the thermal land to the internal/solder-side ground plane(s) should be used to help dissipation. The thermal land can be connected to either AGND or PGND but is recommended to be connected to PGND, the system GND plane(s), which has better heat radiation.

Layout Guidelines (continued)

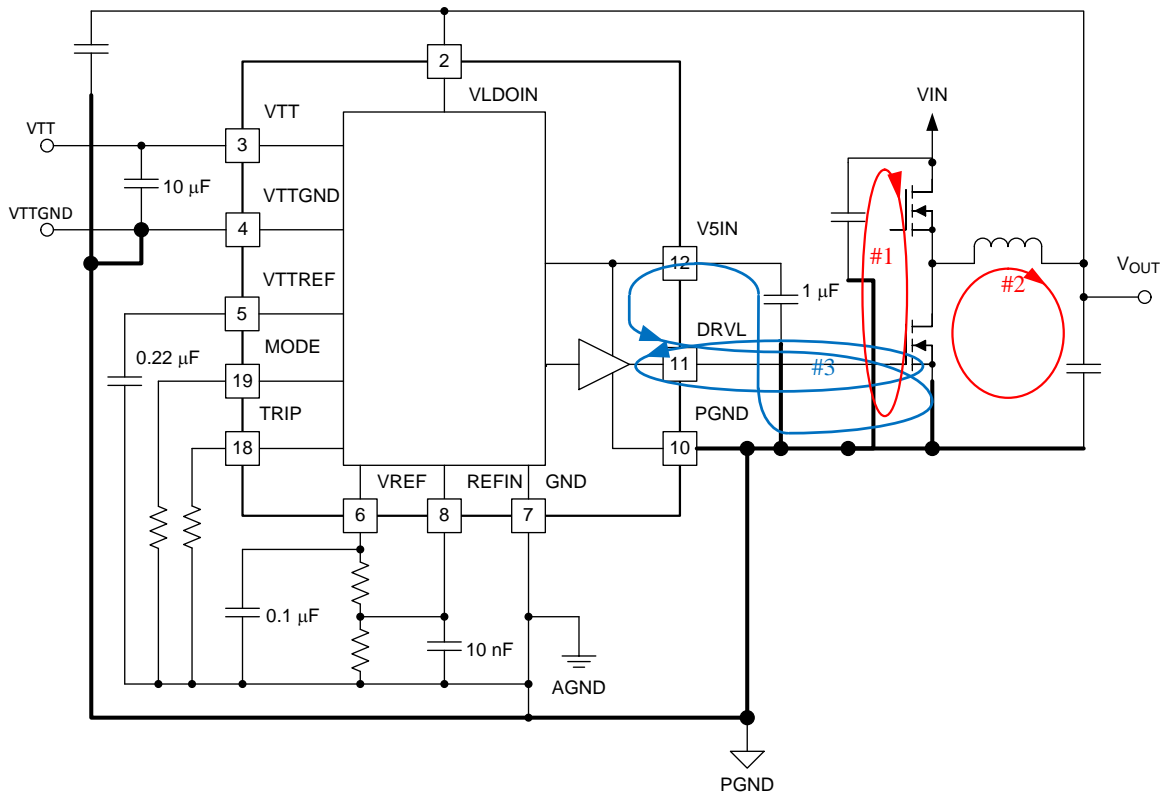

Figure 47. DC/DC Converter Ground System

10.2 Layout Example

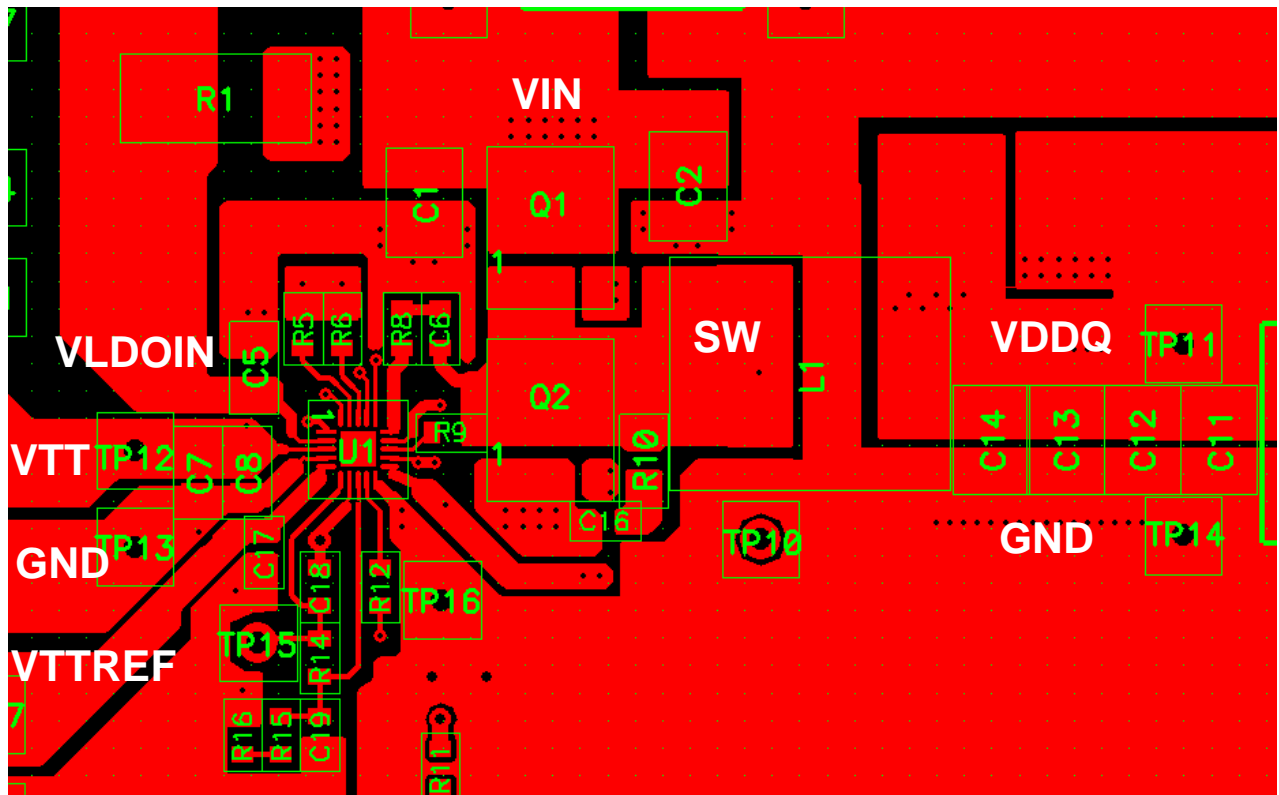

Figure 48. Layout Example

11 器件和文档支持

11.1 接收文档更新通知

要接收文档更新通知，请导航至 TI.com.cn 上的器件产品文件夹。单击右上角的 [通知我](#) 进行注册，即可每周接收产品信息更改摘要。有关更改的详细信息，请查看任何已修订文档中包含的修订历史记录。

11.2 社区资源

下列链接提供到 TI 社区资源的连接。链接的内容由各个分销商“按照原样”提供。这些内容并不构成 TI 技术规范，并且不一定反映 TI 的观点；请参阅 TI 的 [《使用条款》](#)。

TI E2E™ 在线社区 [TI 的工程师对工程师 \(E2E\) 社区](#)。此社区的创建目的在于促进工程师之间的协作。在 e2e.ti.com 中，您可以咨询问题、分享知识、拓展思路并与同行工程师一道帮助解决问题。

设计支持 [TI 参考设计支持](#) 可帮助您快速查找有帮助的 E2E 论坛、设计支持工具以及技术支持的联系信息。

11.3 商标

D-CAP, D-CAP2, E2E are trademarks of Texas Instruments.
All other trademarks are the property of their respective owners.

11.4 静电放电警告



ESD 可能会损坏该集成电路。德州仪器 (TI) 建议通过适当的预防措施处理所有集成电路。如果不遵守正确的处理措施和安装程序，可能会损坏集成电路。

ESD 的损坏小至导致微小的性能降级，大至整个器件故障。精密的集成电路可能更容易受到损坏，这是因为非常细微的参数更改都可能会导致器件与其发布的规格不相符。

11.5 术语表

[SLYZ022](#) — *TI 术语表*。

这份术语表列出并解释术语、缩写和定义。

12 机械、封装和可订购信息

以下页面包含机械、封装和可订购信息。这些信息是指定器件的最新可用数据。数据如有变更，恕不另行通知，且不会对此文档进行修订。如需获取此数据表的浏览器版本，请查阅左侧的导航栏。

PACKAGING INFORMATION

Orderable part number	Status (1)	Material type (2)	Package Pins	Package qty Carrier	RoHS (3)	Lead finish/ Ball material (4)	MSL rating/ Peak reflow (5)	Op temp (°C)	Part marking (6)
TPS51916RUKR	Active	Production	WQFN (RUK) 20	3000 LARGE T&R	Yes	NIPDAU	Level-2-260C-1 YEAR	-40 to 85	51916
TPS51916RUKR.B	Active	Production	WQFN (RUK) 20	3000 LARGE T&R	Yes	NIPDAU	Level-2-260C-1 YEAR	-40 to 85	51916
TPS51916RUKRG4	Active	Production	WQFN (RUK) 20	3000 LARGE T&R	Yes	NIPDAU	Level-2-260C-1 YEAR	-40 to 85	51916
TPS51916RUKRG4.B	Active	Production	WQFN (RUK) 20	3000 LARGE T&R	Yes	NIPDAU	Level-2-260C-1 YEAR	-40 to 85	51916
TPS51916RUKT	Active	Production	WQFN (RUK) 20	250 SMALL T&R	Yes	NIPDAU SN	Level-2-260C-1 YEAR	-40 to 85	51916
TPS51916RUKT.B	Active	Production	WQFN (RUK) 20	250 SMALL T&R	Yes	NIPDAU	Level-2-260C-1 YEAR	-40 to 85	51916

⁽¹⁾ **Status:** For more details on status, see our [product life cycle](#).

⁽²⁾ **Material type:** When designated, preproduction parts are prototypes/experimental devices, and are not yet approved or released for full production. Testing and final process, including without limitation quality assurance, reliability performance testing, and/or process qualification, may not yet be complete, and this item is subject to further changes or possible discontinuation. If available for ordering, purchases will be subject to an additional waiver at checkout, and are intended for early internal evaluation purposes only. These items are sold without warranties of any kind.

⁽³⁾ **RoHS values:** Yes, No, RoHS Exempt. See the [TI RoHS Statement](#) for additional information and value definition.

⁽⁴⁾ **Lead finish/Ball material:** Parts may have multiple material finish options. Finish options are separated by a vertical ruled line. Lead finish/Ball material values may wrap to two lines if the finish value exceeds the maximum column width.

⁽⁵⁾ **MSL rating/Peak reflow:** The moisture sensitivity level ratings and peak solder (reflow) temperatures. In the event that a part has multiple moisture sensitivity ratings, only the lowest level per JEDEC standards is shown. Refer to the shipping label for the actual reflow temperature that will be used to mount the part to the printed circuit board.

⁽⁶⁾ **Part marking:** There may be an additional marking, which relates to the logo, the lot trace code information, or the environmental category of the part.

Multiple part markings will be inside parentheses. Only one part marking contained in parentheses and separated by a "~" will appear on a part. If a line is indented then it is a continuation of the previous line and the two combined represent the entire part marking for that device.

Important Information and Disclaimer: The information provided on this page represents TI's knowledge and belief as of the date that it is provided. TI bases its knowledge and belief on information provided by third parties, and makes no representation or warranty as to the accuracy of such information. Efforts are underway to better integrate information from third parties. TI has taken and continues to take reasonable steps to provide representative and accurate information but may not have conducted destructive testing or chemical analysis on incoming materials and chemicals. TI and TI suppliers consider certain information to be proprietary, and thus CAS numbers and other limited information may not be available for release.

In no event shall TI's liability arising out of such information exceed the total purchase price of the TI part(s) at issue in this document sold by TI to Customer on an annual basis.

GENERIC PACKAGE VIEW

RUK 20

WQFN - 0.8 mm max height

3 x 3, 0.4 mm pitch

PLASTIC QUAD FLATPACK - NO LEAD

This image is a representation of the package family, actual package may vary.
Refer to the product data sheet for package details.

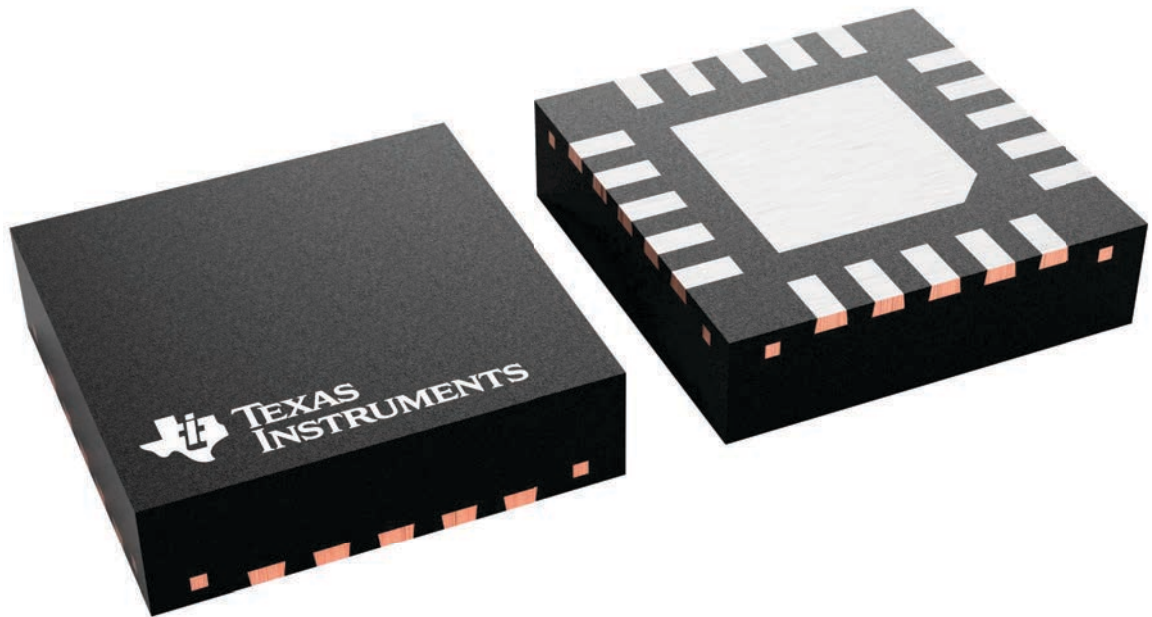

4229651/A

RUK0020B

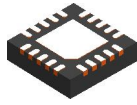

PACKAGE OUTLINE

WQFN - 0.8 mm max height

PLASTIC QUAD FLATPACK - NO LEAD

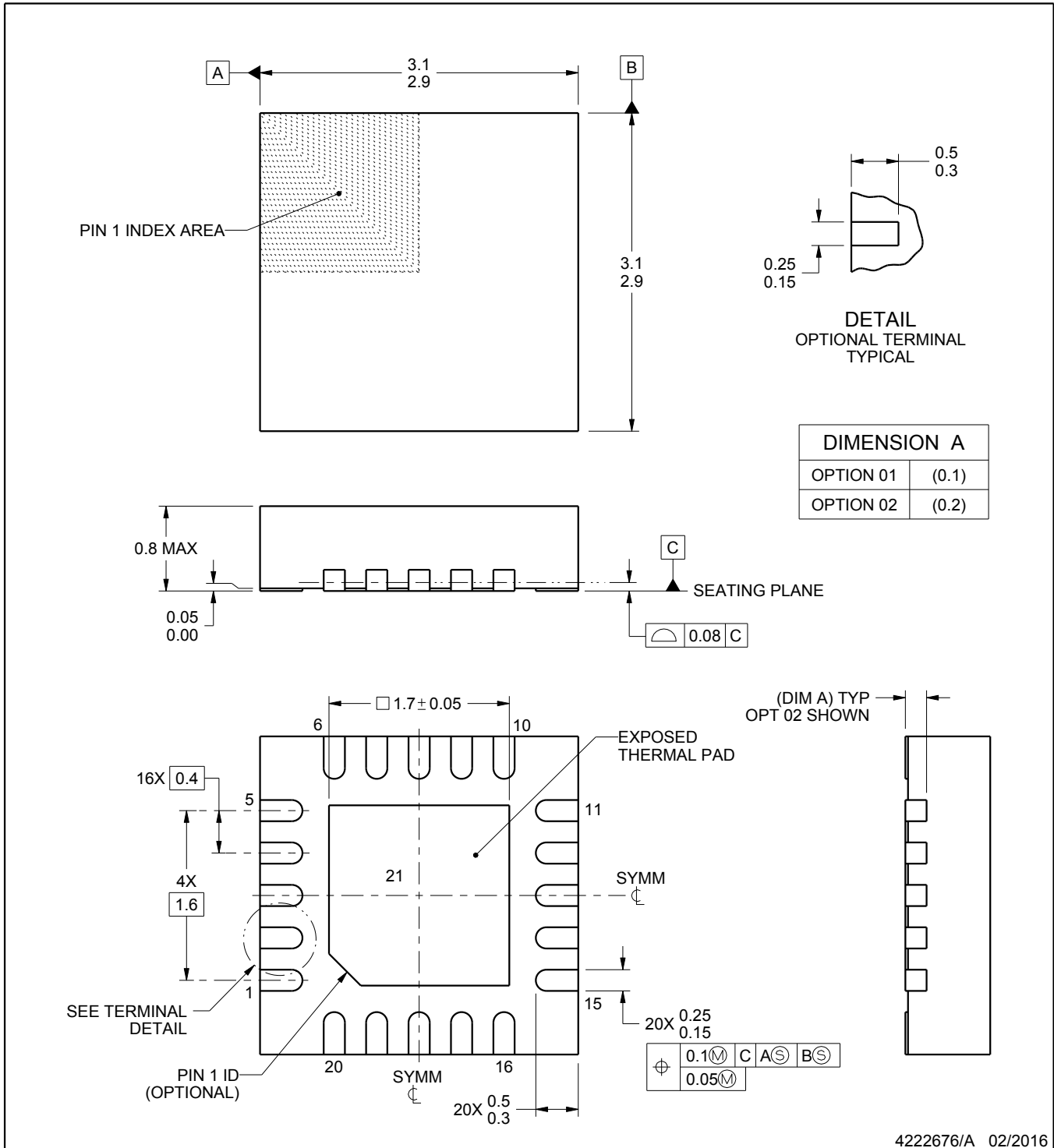

4222676/A 02/2016

NOTES:

1. All linear dimensions are in millimeters. Any dimensions in parenthesis are for reference only. Dimensioning and tolerancing per ASME Y14.5M.
2. This drawing is subject to change without notice.
3. The package thermal pad must be soldered to the printed circuit board for thermal and mechanical performance.

EXAMPLE BOARD LAYOUT

RUK0020B

WQFN - 0.8 mm max height

PLASTIC QUAD FLATPACK - NO LEAD

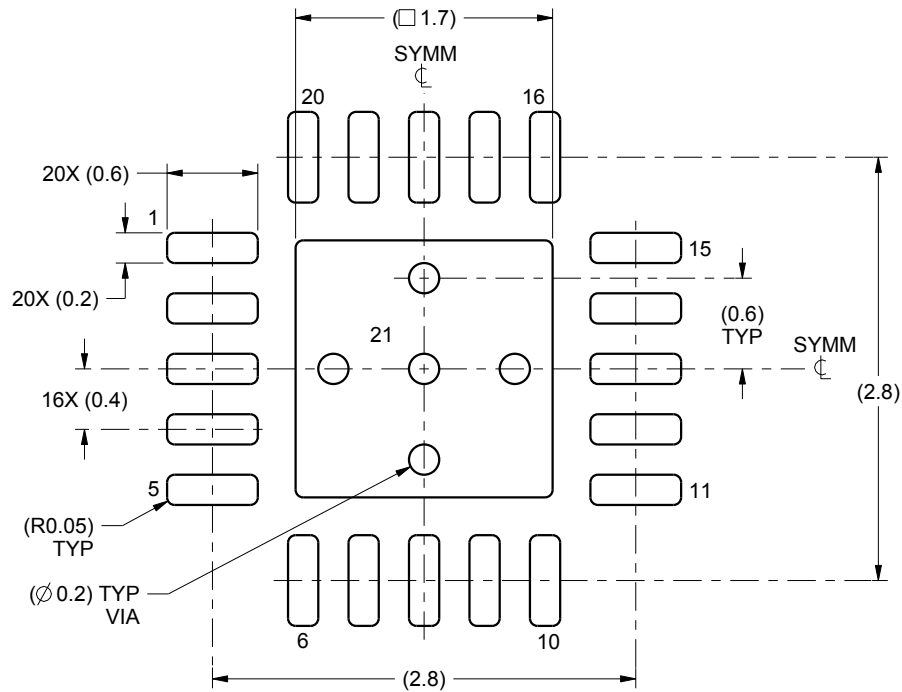

LAND PATTERN EXAMPLE
SCALE:20X

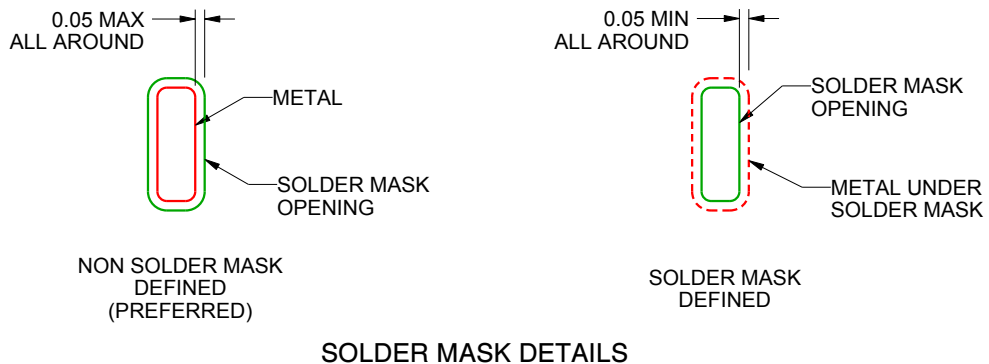

4222676/A 02/2016

NOTES: (continued)

4. This package is designed to be soldered to a thermal pad on the board. For more information, see Texas Instruments literature number SLUA271 (www.ti.com/lit/slua271).
5. Vias are optional depending on application, refer to device data sheet. If any vias are implemented, refer to their locations shown on this view. It is recommended that vias under paste be filled, plugged or tented.

EXAMPLE STENCIL DESIGN

RUK0020B

WQFN - 0.8 mm max height

PLASTIC QUAD FLATPACK - NO LEAD

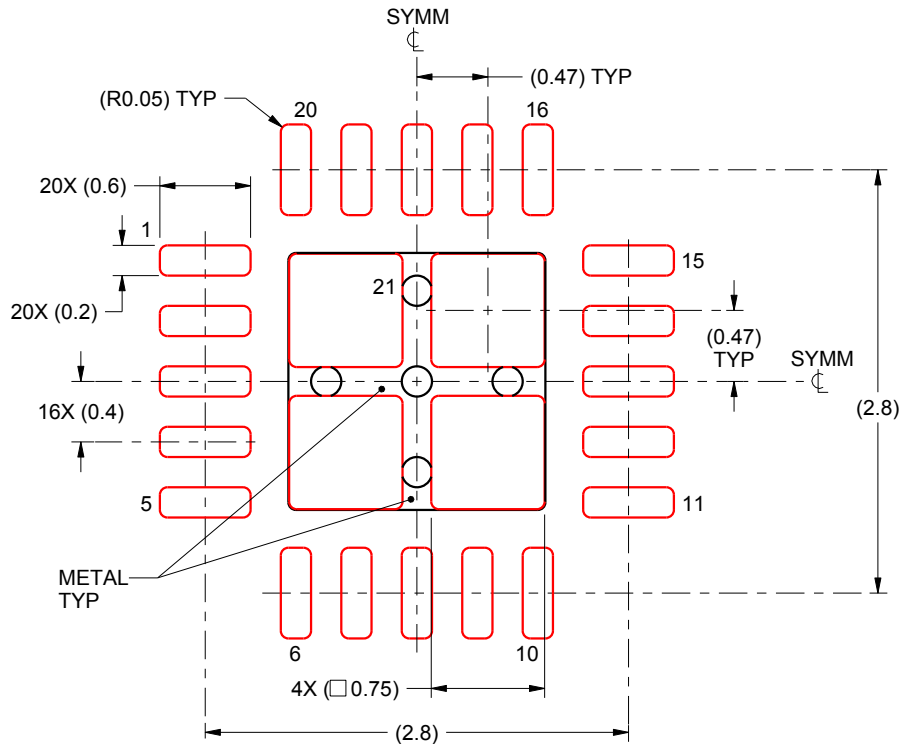

SOLDER PASTE EXAMPLE BASED ON 0.1 mm THICK STENCIL

EXPOSED PAD 21:
78% PRINTED SOLDER COVERAGE BY AREA UNDER PACKAGE
SCALE:20X

4222676/A 02/2016

NOTES: (continued)

6. Laser cutting apertures with trapezoidal walls and rounded corners may offer better paste release. IPC-7525 may have alternate design recommendations.

重要通知和免责声明

TI“按原样”提供技术和可靠性数据（包括数据表）、设计资源（包括参考设计）、应用或其他设计建议、网络工具、安全信息和其他资源，不保证没有瑕疵且不做任何明示或暗示的担保，包括但不限于对适销性、与某特定用途的适用性或不侵犯任何第三方知识产权的暗示担保。

这些资源可供使用 TI 产品进行设计的熟练开发人员使用。您将自行承担以下全部责任：(1) 针对您的应用选择合适的 TI 产品，(2) 设计、验证并测试您的应用，(3) 确保您的应用满足相应标准以及任何其他安全、安保法规或其他要求。

这些资源如有变更，恕不另行通知。TI 授权您仅可将这些资源用于研发本资源所述的 TI 产品的相关应用。严禁以其他方式对这些资源进行复制或展示。您无权使用任何其他 TI 知识产权或任何第三方知识产权。对于因您对这些资源的使用而对 TI 及其代表造成的任何索赔、损害、成本、损失和债务，您将全额赔偿，TI 对此概不负责。

TI 提供的产品受 [TI 销售条款](#)、[TI 通用质量指南](#) 或 [ti.com](#) 上其他适用条款或 TI 产品随附的其他适用条款的约束。TI 提供这些资源并不会扩展或以其他方式更改 TI 针对 TI 产品发布的适用的担保或担保免责声明。除非德州仪器 (TI) 明确将某产品指定为定制产品或客户特定产品，否则其产品均为按确定价格收入目录的标准通用器件。

TI 反对并拒绝您可能提出的任何其他或不同的条款。

版权所有 © 2026，德州仪器 (TI) 公司

最后更新日期：2025 年 10 月