

适用于成本敏感型系统的 TLV900x 低功耗、RRIO、1MHz 运算放大器

1 特性

- 可扩展 CMOS 放大器，适用于低成本应用
- 轨至轨输入和输出
- 低输入失调电压：±0.4mV
- 单位带宽增益积：1MHz
- 低宽带噪声：27nV/√Hz
- 低输入偏置电流：5pA
- 低静态电流：60μA/通道
- 单位增益稳定
- 内置 RFI 和 EMI 滤波器
- 可在电源电压低至 1.8V 的情况下运行
- 由于具有电阻式开环输出阻抗，因此可在更高的容性负载下更轻松地实现稳定
- 工作温度范围：-40°C 至 125°C

2 应用

- 传感器信号调节
- 电源模块
- 有源滤波器
- 低侧电流检测
- 烟雾探测器
- 运动探测器
- 可穿戴设备
- 大型和小型家用电器
- EPOS
- 条形码扫描仪
- 个人电子产品
- HVAC：暖通空调
- 电机控制：交流感应

3 说明

TLV900x 系列包括单通道 (TLV9001)、双通道 (TLV9002)、和四通道 (TLV9004) 低电压 (1.8V 至 5.5V) 运算放大器，具有轨至轨输入和输出摆幅能力。这些运算放大器为空间受限、需要低压运行和高容性负载驱动的应用 (例如烟雾探测器、可穿戴电子产品和小型电器) 提供了具有成本效益的解决方案。TLV900x 系列的电容负载驱动器具有 500pF 的电容，而电阻式开环输出阻抗使其能够在更高的电容负载下更轻松地实现稳定。这些运算放大器专为低工作电压 (1.8V 至 5.5V) 而设计，性能规格类似于 TLV600x 器件。

TLV900x 系列稳健耐用的设计可简化电路设计。这些运算放大器具有单位增益稳定性，集成了 RFI 和 EMI 抑制滤波器，并且在过驱情况下不会出现相位反转。

TLV900x 器件具有关断模式 (TLV9001S、TLV9002S 和 TLV9004S)，允许放大器切换至典型电流消耗低于 1μA 的待机模式。

针对所有通道型号 (单通道、双通道和四通道) 提供微型封装 (如 SOT-553 和 WSON) 以及行业标准封装 (如 SOIC、MSOP、SOT-23 和 TSSOP 封装)。

器件信息

器件型号 ⁽¹⁾	封装	封装尺寸 (标称值)
TLV9001	SOT-23 (5)	1.60mm × 2.90mm
	SC70 (5)	1.25mm × 2.00mm
	SOT-553 (5) ⁽²⁾	1.65mm × 1.20mm
	X2SON (5)	0.80mm × 0.80mm
TLV9001S	SOT-23 (6)	1.60mm × 2.90mm
	SC70 (6)	1.25mm × 2.00mm
TLV9002	SOIC (8)	3.91mm × 4.90mm
	WSON (8)	2.00mm × 2.00mm
	VSSOP (8)	3.00mm × 3.00mm
	SOT-23 (8)	1.60mm × 2.90mm
	TSSOP (8)	3.00mm × 4.40mm
TLV9002S	VSSOP (10)	3.00mm × 3.00mm
	X2QFN (10)	1.50mm × 2.00mm
	DSBGA (9)	1.00mm × 1.00mm
TLV9004	SOIC (14)	8.65mm × 3.91mm
	SOT-23 (14)	4.20 mm × 2.00 mm
	TSSOP (14)	4.40mm × 5.00mm
	WQFN (16)	3.00mm × 3.00mm
	X2QFN (14)	2.00mm × 2.00mm
TLV9004S	WQFN (16)	3.00mm × 3.00mm

(1) 如需了解所有可用封装，请参阅数据表末尾的可订购产品附录。

(2) 仅表示封装为预发布。



$$\frac{V_{OUT}}{V_{IN}} = \left(1 + \frac{R_F}{R_G}\right) \left(\frac{1}{1 + sR_1C_1}\right)$$

单极低通滤波器



内容

1 特性.....	1	8.3 特性说明.....	27
2 应用.....	1	8.4 过载恢复.....	28
3 说明.....	1	8.5 关断.....	28
4 修订历史记录.....	2	8.6 器件功能模式.....	28
5 器件比较表.....	6	9 应用和实现.....	29
6 引脚配置和功能.....	7	9.1 应用信息.....	29
7 规格.....	14	9.2 典型应用.....	29
7.1 绝对最大额定值.....	14	10 电源相关建议.....	34
7.2 ESD 等级.....	14	10.1 输入和 ESD 保护.....	34
7.3 建议运行条件.....	14	11 布局.....	35
7.4 热性能信息：TLV9001.....	15	11.1 布局指南.....	35
7.5 热性能信息：TLV9001S.....	15	11.2 布局示例.....	35
7.6 热性能信息：TLV9002.....	15	12 器件和文档支持.....	36
7.7 热性能信息：TLV9002S.....	16	12.1 文档支持.....	36
7.8 热性能信息：TLV9004.....	16	12.2 接收文档更新通知.....	36
7.9 热性能信息：TLV9004S.....	16	12.3 支持资源.....	36
7.10 电气特征.....	17	12.4 商标.....	36
7.11 典型特性.....	20	12.5 Electrostatic Discharge Caution.....	36
8 详细说明.....	26	12.6 术语表.....	36
8.1 概述.....	26	13 机械、封装和可订购信息.....	37
8.2 功能方框图.....	26		

4 修订历史记录

注：以前版本的页码可能与当前版本的页码不同

Changes from Revision Q (June 2021) to Revision R (November 2021) Page

• 向 <i>器件信息</i> 表中添加了 SOT-23 (14) 封装.....	1
• 向 <i>器件比较表</i> 中添加了 SOT-23 DYY 封装.....	6
• 向 <i>引脚配置和功能</i> 部分中添加了 SOT-23 (14) 封装.....	7
• 向 <i>热性能信息：TLV9004</i> 表中添加了 DYY (SOT-23) 封装的热性能信息.....	16

Changes from Revision P (April 2021) to Revision Q (June 2021) Page

• 将 <i>绝对最大额定值表</i> 中的电源电压 (V+) - (V-) MAX 从 6V 更改为 7V.....	14
-------------------------------------------------------------	----

Changes from Revision O (April 2020) to Revision P (April 2021) Page

• 更新了整个文档中的表格、图和交叉参考的编号格式.....	1
• 向 <i>器件信息</i> 表中添加了 9 引脚 DSBGA 封装.....	1
• 向 <i>器件比较表</i> 中添加了 9 引脚 DSBGA 封装.....	6
• 向 <i>引脚配置和功能</i> 部分中添加了 TLV9002S 9 引脚 DSBGA 封装.....	7
• 向 <i>热性能信息：TLV9002S</i> 表中添加了 TLV9002S 9 引脚 DSBGA 封装.....	16
• 从 <i>器件和文档支持</i> 部分中删除了 <i>相关链接</i> 部分.....	36

Changes from Revision N (January 2020) to Revision O (April 2020) Page

• 删除了 TLV9001S 上的“预发布”标识.....	1
• 删除了 TLV9001SIDCK (6 引脚 SC70) 封装预发布说明.....	7

- 向“热性能信息：TLV9001S”表中添加了 DCK (SC70) 数据..... 15

Changes from Revision M (September 2019) to Revision N (January 2020) Page

- 向器件信息表中添加了 6 引脚 SC70 封装..... 1
- 向器件比较表中添加了 6 引脚 SC70 封装..... 6
- 添加了 TLV9001SIDCK (6 引脚 SC70) 封装引脚..... 7
- 向引脚配置和功能部分中添加了 TLV9001S 6 引脚 SC70 封装..... 7
- 向引脚功能：TLV9001S 中添加了 6 引脚 SC70 引脚图..... 7
- 向热性能信息：TLV9001S 表中添加了 TLV9001S 6 引脚 SC70 封装..... 15

Changes from Revision L (May 2019) to Revision M (September 2019) Page

- 删除了针对 SOT-23-8 (DDF) 封装的预发布备注..... 6
- 向所有 SHDN 引脚功能行中添加了指向关断部分的链接..... 7
- 向特性说明部分中添加了 EMI 抑制部分..... 27
- 更改了关断部分，以添加关于内部上拉电阻器的更多清晰度..... 28

Changes from Revision K (March 2019) to Revision L (May 2019) Page

- 向器件信息表中添加了 SOT-23 (8) 信息..... 1
- 向器件比较表中添加了 SOT-23 DDF 封装..... 6
- 向引脚配置和功能部分中添加了 SOT-23 (DDF)..... 7
- 添加了 DDF (SOT-23) 热性能信息：TLV9002 表..... 15

Changes from Revision J (January 2019) to Revision K (March 2019) Page

- 更改了 TLV9002S ESD 等级标题以包含所有 TLV9002S 封装..... 14
- 删除了热性能信息表中 TLV9002SIRUG 的预览符号..... 16

Changes from Revision I (November 2018) to Revision J (January 2019) Page

- 删除了 TLV9002SIRUGR 的预发布符号..... 1
- 将 TLV9004 WQFN(14) 封装标识符更改为 X2QFN(14) 封装标识符..... 1
- 向器件比较表中添加了 RUG 封装..... 6
- 向器件比较表中添加了 DGS 封装..... 6
- 向器件比较表中添加了关断器件..... 6
- 更改了 TLV9001 DRL 封装引脚图..... 7
- 更改了 TLV9001 DRL 封装的引脚功能..... 7
- 删除了 TLV9002SIRUGR (X2QFN) 引脚图中的封装预发布说明..... 7
- 添加了 TLV9004IRUC 的热性能信息..... 16
- 更改了闭环增益与频率间的关系图的图例..... 20

Changes from Revision H (October 2018) to Revision I (November 2018) Page

- 向 ESD 等级表中添加了 TLV9002SIDGS..... 14

Changes from Revision G (September 2018) to Revision H (October 2018) Page

- 在整个数据表中将 TLV9001 DCK 封装更改为：TLV9001T DCK 封装..... 7

Changes from Revision F (August 2018) to Revision G (September 2018) Page

- 添加了器件比较表..... 6
- 更改了所有器件和所有封装的引脚名称..... 7
- 更改了一些 TLV9001 引脚的引脚名称和 I/O 标识..... 7
- 更改了引脚功能：TLV9004 表 SOIC，TSSOP 列中 V+ 的引脚编号..... 7

Changes from Revision E (July 2018) to Revision F (August 2018) **Page**

• 添加了“可扩展 CMOS 放大器，适用于低成本应用”特性.....	1
• 删除了采用 TSSOP 封装的 TLV9002 和 TLV9004 器件上的“预发布”标识。.....	1
• 向 <i>引脚配置和功能</i> 部分中添加了 TLV9001U DBV (SOT-23) 引脚图.....	7
• 向 <i>引脚功能</i> 部分中添加了 SOT-23 U 引脚.....	7

Changes from Revision D (June 2018) to Revision E (July 2018) **Page**

• 更正了 <i>说明</i> 部分中的拼写错误.....	1
• 向 <i>器件信息</i> 表中添加了 TLV9001 5 引脚 X2SON 封装.....	1
• 向 <i>器件信息</i> 表中添加了 TLV9001S 6 引脚 SOT-23 封装.....	1
• 向 <i>器件信息</i> 表中添加了 TLV9004 14 引脚和 16 引脚 WQFN 封装.....	1
• 向 <i>引脚配置和功能</i> 部分中添加了 TLV9001 DPW (X2SON) 引脚图.....	7
• 向 <i>引脚配置和功能</i> 部分中添加了 TLV9001S 6 引脚 SOT-23 封装.....	7
• 向 <i>引脚配置和功能</i> 部分中添加了 TLV9004 RTE 引脚信息.....	7
• 向 <i>热性能信息</i> : TLV9001 表中添加了 DPW (X2SON) 和 DRL (SOT-553) 封装.....	15
• 向 <i>规格</i> 部分中添加了 <i>热性能信息</i> : TLV9001S 表.....	15
• 向 <i>热性能信息</i> : TLV9002 表中添加了 RUG (X2QFN) 封装.....	15
• 向 <i>热性能信息</i> : TLV9004 表中添加了 RTE (WQFN) 和 RUC (WQFN) 封装.....	16

Changes from Revision C (May 2018) to Revision D (June 2018) **Page**

• 向 <i>说明</i> 部分添加了关断文本.....	1
• 向 <i>器件信息</i> 表中添加了 TLV9002S 和 TLV9004S 器件.....	1
• 向 <i>器件信息</i> 表中添加了 TLV9002S 10 引脚 X2QFN 封装.....	1
• 向 <i>引脚配置和功能</i> 部分中添加了 TLV9002S DGS 封装引脚信息.....	7
• 向 <i>规格</i> 部分中添加了 <i>热性能信息</i> : TLV9001 表.....	15
• 向 <i>规格</i> 部分中添加了 <i>热性能信息</i> : TLV9004 表.....	16
• 向 <i>电气特性</i> : V_S (总电源电压) = (V+) - (V-) = 1.8V 至 5.5V 表中添加了“关断”部分.....	17
• 添加了关断部分.....	28

Changes from Revision B (March 2018) to Revision C (May 2018) **Page**

• 向 <i>器件信息</i> 表中添加了 TLV9002 16 引脚 TSSOP 封装.....	1
• 向 <i>器件信息</i> 表中添加了 TLV9002 10 引脚 X2QFN 封装.....	1
• 向 <i>引脚配置和功能</i> 部分中添加了 TLV9002S DGS 封装引脚图.....	7
• 向 <i>引脚配置和功能</i> 部分中添加了 TLV9004 引脚图和引脚配置表.....	7
• 向 <i>引脚配置和功能</i> 部分中添加了 TLV9004S 引脚图和引脚配置表.....	7
• 将 TLV9002 D (SOIC) 结至环境热阻值从 147.4°C/W 更改为 207.9°C/W.....	15
• 将 TLV9002 D (SOIC) 结至外壳 (顶部) 热阻从 94.3°C/W 更改为 92.8°C/W.....	15
• 将 TLV9002 D (SOIC) 结至电路板热阻从 89.5°C/W 更改为 129.7°C/W.....	15
• 将 TLV9002 D (SOIC) 结至顶特征参数从 47.3°C/W 更改为 26°C/W.....	15
• 将 TLV9002 D (SOIC) 结至电路板特征参数从 89°C/W 更改为 127.9°C/W.....	15
• 向 <i>热性能信息</i> : TLV9002 表中添加了 DSG (WSON) 的热性能信息.....	15
• 向 <i>热性能信息</i> : TLV9002 表中添加了 TLV9002 PW (TSSOP) 的热性能信息.....	15
• 向 <i>热性能信息</i> : TLV9002 表中添加了 PW (TSSOP) 的热性能信息.....	16

Changes from Revision A (December 2017) to Revision B (March 2018) **Page**

• 在 <i>器件信息</i> 表中，向 TLV9001 封装、TLV9004 封装和 TLV9002 8 引脚 VSSOP 封装添加了封装预发布说明.....	1
• 向 <i>引脚配置和功能</i> 部分的 TLV9001、TLV9004 和 TLV9002 VSSOP 封装引脚图中添加了封装预发布说明.....	7
• 从“ <i>引脚配置和功能</i> ”部分的 TLV9002 DSG (WSON) 引脚图中删除了封装预发布说明.....	7
• 从 <i>引脚配置和功能</i> 部分的 TLV9002 RUG (X2QFN) 引脚图中删除了封装预发布说明.....	7
• 向 <i>热性能信息</i> : TLV9002 表中添加了 DSG (WSON) 封装的热性能信息.....	15

-
- 删除了热性能信息：TLV9002 表中 DSG (WSON) 封装的封装预发布说明..... 15
 - 向热性能信息：TLV9004 表中添加了 D (SOIC) 封装的热性能信息..... 16
-

Changes from Revision * (October 2017) to Revision A (December 2017)**Page**

-
- 将器件状态从“预告信息”更改为“量产数据/混合状态” 1
-

5 器件比较表

器件	通道数	封装引线														
		SC70 DCK	SOIC D	SOT-23 DBV	SOT-23 DYY	SOT-553 DRL	TSSOP PW	VSSOP DGK	SOT-23 DDF	WQFN RTE	WSON DSG	X2QFN RUC	X2SON DPW	X2QFN RUG	VSSOP DGS	DSBGA YCK
TLV9001	1	5	—	5	—	5	—	—	—	—	—	—	5	—	—	—
TLV9001S		6	—	6	—	—	—	—	—	—	—	—	—	—	—	—
TLV9002	2	—	8	—	—	—	8	8	8	—	8	—	—	—	—	—
TLV9002S		—	—	—	—	—	—	—	—	—	—	—	—	10	10	9
TLV9004	4	—	14	—	14	—	14	—	—	16	—	14	—	—	—	—
TLV9004S		—	—	—	—	—	—	—	—	16	—	—	—	—	—	—

6 引脚配置和功能



图 6-1. TLV9001 DBV , TLV9001T DCK 封装
5 引脚 SOT-23 , SC70
顶视图



图 6-2. TLV9001 DCK 封装、TLV9001 DRL 封装、
TLV9001U DBV 封装
5 引脚 SC70、SOT-553、SOT-23
顶视图

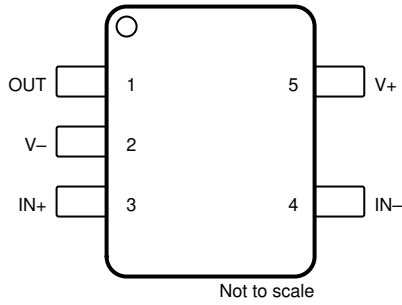

图 6-3. TLV9001 DPW 封装
5 引脚 X2SON
顶视图

表 6-1. 引脚功能 : TLV9001

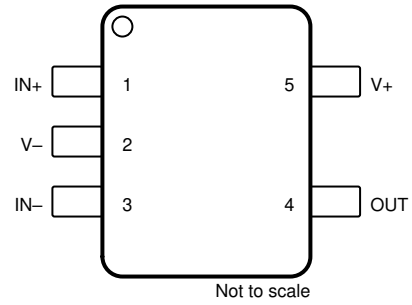
名称	引脚			I/O	说明
	SOT-23 , SC70(T)	SC70、 SOT-23(U)、 SOT-553	X2SON		
IN -	4	3	2	I	反相输入
IN+	3	1	4	I	同相输入
OUT	1	4	1	O	输出
V -	2	2	3	I 或 —	负 (低) 电源或接地 (对于单电源供电)
V+	5	5	5	I	正 (高) 电源



图 6-4. TLV9001S DBV 封装
6 引脚 SOT-23
顶视图



图 6-5. TLV9001S DCK 封装
6 引脚 SC70
顶视图

表 6-2. 引脚功能 : TLV9001S

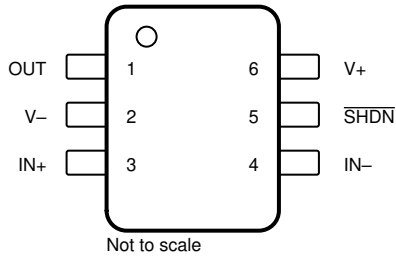
名称	引脚		I/O	说明
	SOT-23	SC70		
IN -	4	3	I	反相输入
IN+	3	1	I	同相输入
OUT	1	4	O	输出
SHDN	5	5	I	关断：低 = 禁用放大器，高 = 启用放大器。更多信息，请参阅节 8.5。
V -	2	2	I 或 —	负（低）电源或接地（对于单电源供电）
V+	6	6	I	正（高）电源

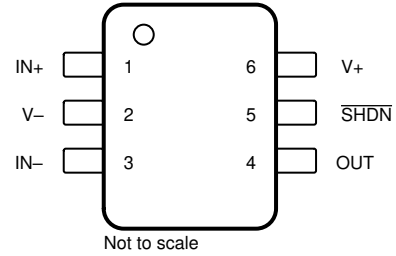

图 6-6. TLV9002 D, DGK, PW, DDF 封装
8 引脚 SOIC, VSSOP, TSSOP, SOT-23
顶视图



图 6-7. TLV9002 DSG 封装
8 引脚 WSON (带有外露散热焊盘)
顶视图

A. 将散热焊盘连接至 V - 。

表 6-3. 引脚功能 : TLV9002

名称	引脚		I/O	说明
	编号			
IN1 -	2		I	反相输入，通道 1
IN1+	3		I	同相输入，通道 1
IN2 -	6		I	反相输入，通道 2
IN2+	5		I	同相输入，通道 2
OUT1	1		O	输出，通道 1
OUT2	7		O	输出，通道 2
V -	4		I 或 —	负（低）电源或接地（对于单电源供电）

表 6-3. 引脚功能 : TLV9002 (continued)

引脚		I/O	说明
名称	编号		
V+	8	I	正 (高) 电源



图 6-8. TLV9002S DGS 封装
10 引脚 VSSOP
顶视图



图 6-9. TLV9002S RUG 封装
10 引脚 X2QFN
顶视图



图 6-10. TLV9002S YCK 封装
9 引脚 DSBGA (WCSP)
仰视图

表 6-4. 引脚功能 : TLV9002S

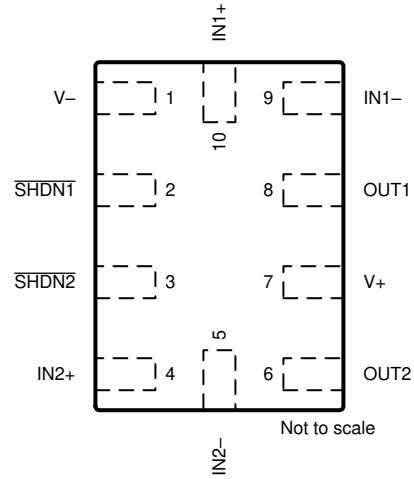
名称	引脚			I/O	说明
	VSSOP	X2QFN	DSBGA (WCSP)		
IN1 -	2	9	B1	I	反相输入, 通道 1
IN1+	3	10	A1	I	同相输入, 通道 1

表 6-4. 引脚功能 : TLV9002S (continued)

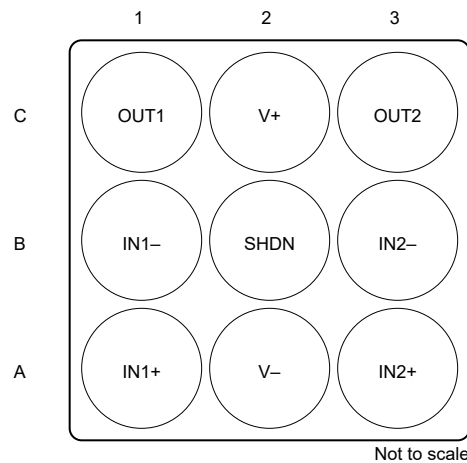
引脚				I/O	说明
名称	VSSOP	X2QFN	DSBGA (WCSP)		
IN2 -	8	5	B3	I	反相输入, 通道 2
IN2+	7	4	A3	I	同相输入, 通道 2
OUT1	1	8	C1	O	输出, 通道 1
OUT2	9	6	C3	O	输出, 通道 2
$\overline{\text{SHDN1}}$	5	2	—	I	关断: 低 = 禁用放大器, 高 = 启用放大器, 通道 1。更多信息, 请参阅节 8.5。
$\overline{\text{SHDN2}}$	6	3	—	I	关断: 低 = 禁用放大器, 高 = 启用放大器, 通道 1。更多信息, 请参阅节 8.5。
$\overline{\text{SHDN}}$	—	—	B2		关断: 低 = 禁用两个放大器, 高 = 启用两个放大器
V -	4	1	A2	I 或 —	负 (低) 电源或接地 (对于单电源供电)
V+	10	7	C2	I	正 (高) 电源



图 6-11. TLV9004 D, DYY, PW 封装
14 引脚 SOIC, SOT-23 (14), TSSOP
顶视图



图 6-12. TLV9004 RUC 封装
14 引脚 X2QFN
顶视图



图 6-13. TLV9004 RTE 封装
16 引脚 WQFN (带有外露散热焊盘)
顶视图

A. 将散热焊盘连接至 V-。

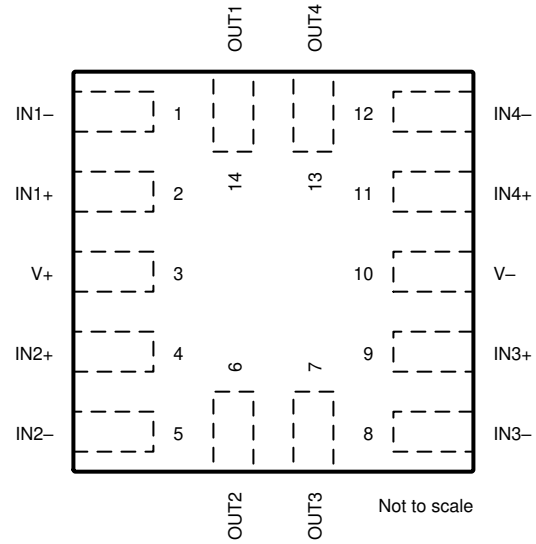
表 6-5. 引脚功能 : TLV9004

名称	引脚			I/O	说明
	SOIC、SOT-23 (14)、TSSOP	WQFN	X2QFN		
IN1 -	2	16	1	I	反相输入, 通道 1
IN1+	3	1	2	I	同相输入, 通道 1
IN2 -	6	4	5	I	反相输入, 通道 2

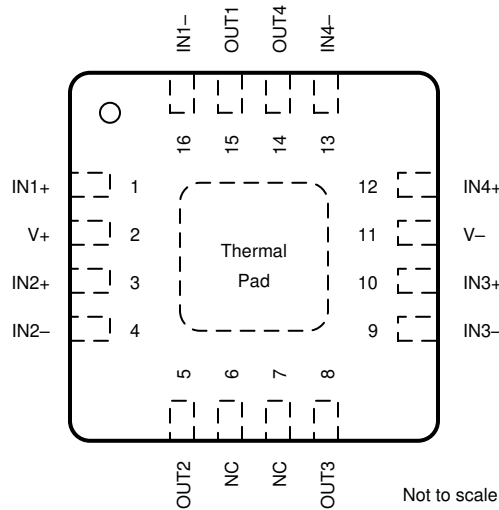
表 6-5. 引脚功能 : TLV9004 (continued)

名称	引脚			I/O	说明
	SOIC、 SOT-23 (14)、 TSSOP	WQFN	X2QFN		
IN2+	5	3	4	I	同相输入，通道 2
IN3 -	9	9	8	I	反相输入，通道 3
IN3+	10	10	9	I	同相输入，通道 3
IN4 -	13	13	12	I	反相输入，通道 4
IN4+	12	12	11	I	同相输入，通道 4
NC	—	6、7	—	—	无内部连接
OUT1	1	15	14	O	输出，通道 1
OUT2	7	5	6	O	输出，通道 2
OUT3	8	8	7	O	输出，通道 3
OUT4	14	14	13	O	输出，通道 4
V -	11	11	10	I 或 —	负 (低) 电源或接地 (对于单电源供电)
V+	4	2	3	I	正 (高) 电源



A. 将散热焊盘连接至 V⁻。

图 6-14. TLV9004S RTE 封装
16 引脚 WQFN (带有外露散热焊盘)
顶视图

表 6-6. 引脚功能：TLV9004S

引脚		I/O	说明
名称	编号		
IN1+	1	I	同相输入
IN1 -	16	I	反相输入
IN2+	3	I	同相输入
IN2 -	4	I	反相输入
IN3+	10	I	同相输入
IN3 -	9	I	反相输入
IN4+	12	I	同相输入
IN4 -	13	I	反相输入
SHDN12	6	I	关断：低 = 禁用放大器，高 = 启用放大器，通道 1 和 2。更多信息，请参阅节 8.5。
SHDN34	7	I	关断：低 = 禁用放大器，高 = 启用放大器，通道 3 和 4。更多信息，请参阅节 8.5。
OUT1	15	O	输出
OUT2	5	O	输出
OUT3	8	O	输出
OUT4	14	O	输出
V -	11	I 或 -	负（低）电源或接地（对于单电源供电）
V+	2	I	正（高）电源

7 规格

7.1 绝对最大额定值

在工作温度范围内（除非另有说明）⁽¹⁾

		最小值	最大值	单位	
电源电压 (V+) - (V-)			7	V	
信号输入引脚	电压 ⁽²⁾	共模	(V-) - 0.5	(V+) + 0.5	V
		差分	(V+) - (V-) + 0.2		V
	电流 ⁽²⁾	-10	10	mA	
输出短路 ⁽³⁾		持续			
温度, T _A		-55	150	°C	
结温, T _J			150	°C	
贮存温度, T _{stg}		-65	150	°C	

- (1) 超出绝对最大额定值下所列的值的应力可能会对器件造成损坏。这些仅仅是压力额定值，并不表示器件在这些条件下以及在建议运行条件以外的任何其他条件下能够正常运行。长时间处于绝对最大额定条件下可能会影响器件的可靠性。
- (2) 输入引脚被二极管钳制至电源轨。摆幅超过电源轨 0.5V 的输入信号的电流必须限制在 10mA 或者更少。
- (3) 对地短路，每个封装对应一个放大器。

7.2 ESD 等级

TLV9002S 封装		值	单位
V _(ESD) 静电放电	人体放电模型 (HBM), 符合 ANSI/ESDA/JEDEC JS-001 标准 ⁽¹⁾	±1500	V
	充电器件模型 (CDM), 符合 JEDEC 规范 JESD22-C101 ⁽²⁾	±1500	
所有其他封装			
V _(ESD) 静电放电	人体放电模型 (HBM), 符合 ANSI/ESDA/JEDEC JS-001 标准 ⁽¹⁾	±2000	V
	充电器件模型 (CDM), 符合 JEDEC 规范 JESD22-C101 ⁽²⁾	±1000	

- (1) JEDEC 文档 JEP155 指出：500V HBM 时能够在标准 ESD 控制流程下安全生产。
- (2) JEDEC 文件 JEP157 指出：250V CDM 可实现在标准 ESD 控制流程下安全生产。

7.3 建议运行条件

在工作温度范围内（除非另有说明）

		最小值	最大值	单位
V _S	电源电压	1.8	5.5	V
T _A	额定温度	-40	125	°C

7.4 热性能信息：TLV9001

热指标 ⁽¹⁾	TLV9001				单位
	DBV (SOT-23)	DCK (SC70)	DPW (X2SON)	DRL (SOT-553) ⁽²⁾	
	5 引脚	5 引脚	5 引脚	5 引脚	
R _{θJA} 结至环境热阻	232.9	239.6	470.0	待定	°C/W
R _{θJC(top)} 结至外壳 (顶部) 热阻	153.8	148.5	211.9	待定	°C/W
R _{θJB} 结至电路板热阻	100.9	82.3	334.8	待定	°C/W
ψ _{JT} 结至顶部特征参数	77.2	54.5	29.8	待定	°C/W
ψ _{JB} 结至电路板特征参数	100.4	81.8	333.2	待定	°C/W

- (1) 有关新旧热性能指标的更多信息，请参阅 [半导体和 IC 封装热指标](#)。
 (2) 此 TLV9001 封装选项仅为预发布版。

7.5 热性能信息：TLV9001S

热指标 ⁽¹⁾	TLV9001S		单位
	DBV (SOT-23)	DCK (SC70)	
	6 引脚	6 引脚	
R _{θJA} 结至环境热阻	232.9	215.6	°C/W
R _{θJC(top)} 结至外壳 (顶部) 热阻	153.8	146.4	°C/W
R _{θJB} 结至电路板热阻	100.9	72.0	°C/W
ψ _{JT} 结至顶部特征参数	77.2	55.0	°C/W
ψ _{JB} 结至电路板特征参数	100.4	71.7	°C/W

- (1) 有关新旧热性能指标的更多信息，请参阅 [半导体和 IC 封装热指标](#)。

7.6 热性能信息：TLV9002

热指标 ⁽¹⁾	TLV9002						单位
	D (SOIC)	DGK (VSSOP)	DGS (VSSOP)	DSG (WSON)	PW (TSSOP)	DDF (SOT-23)	
	8 个引脚	8 引脚	10 引脚	8 个引脚	8 引脚	8 引脚	
R _{θJA} 结至环境热阻	207.9	201.2	169.5	103.2	200.7	183.7	°C/W
R _{θJC(top)} 结至外壳 (顶部) 热阻	92.8	85.7	84.1	120.1	95.4	112.5	°C/W
R _{θJB} 结至电路板热阻	129.7	122.9	113	68.8	128.6	98.2	°C/W
ψ _{JT} 结至顶部特征参数	26	21.2	15.8	14.7	27.2	18.8	°C/W
ψ _{JB} 结至电路板特征参数	127.9	121.4	111.6	68.5	127.2	97.6	°C/W

- (1) 有关新旧热性能指标的更多信息，请参阅 [半导体和 IC 封装热指标](#)。

7.7 热性能信息：TLV9002S

热指标 ⁽¹⁾		TLV9002S			单位
		DGS (VSSOP)	RUG (X2QFN)	YCK (DSBGA)	
		10 引脚	10 引脚	9 引脚	
$R_{\theta JA}$	结至环境热阻	169.5	194.2	101.2	°C/W
$R_{\theta JC(top)}$	结至外壳 (顶部) 热阻	84.1	90.3	0.9	°C/W
$R_{\theta JB}$	结至电路板热阻	113	122.2	33.8	°C/W
ψ_{JT}	结至顶部特征参数	15.8	3.5	0.5	°C/W
ψ_{JB}	结至电路板特征参数	111.6	118.8	33.8	°C/W

(1) 有关新旧热性能指标的更多信息，请参阅 [半导体和 IC 封装热指标](#)。

7.8 热性能信息：TLV9004

热指标 ⁽¹⁾		TLV9004				单位	
		D (SOIC)	DYY (SOT-23)	PW (TSSOP)	RTE (WQFN)		RUC (X2QFN)
		14 引脚	14 引脚	14 引脚	16 引脚		14 引脚
$R_{\theta JA}$	结至环境热阻	102.1	154.3	148.3	66.4	205.5	°C/W
$R_{\theta JC(top)}$	结至外壳 (顶部) 热阻	56.8	86.8	68.1	69.3	72.5	°C/W
$R_{\theta JB}$	结至电路板热阻	58.5	67.9	92.7	41.7	150.2	°C/W
ψ_{JT}	结至顶部特征参数	20.5	10.1	16.9	5.7	3.0	°C/W
ψ_{JB}	结至电路板特征参数	58.1	67.5	91.8	41.5	149.6	°C/W

(1) 有关新旧热性能指标的更多信息，请参阅 [半导体和 IC 封装热指标](#)。

7.9 热性能信息：TLV9004S

热指标 ⁽¹⁾		TLV9004S	单位
		RTE (WQFN)	
		16 引脚	
$R_{\theta JA}$	结至环境热阻	66.4	°C/W
$R_{\theta JC(top)}$	结至外壳 (顶部) 热阻	69.3	°C/W
$R_{\theta JB}$	结至电路板热阻	41.7	°C/W
ψ_{JT}	结至顶部特征参数	5.7	°C/W
ψ_{JB}	结至电路板特征参数	41.5	°C/W

(1) 有关新旧热性能指标的更多信息，请参阅 [半导体和 IC 封装热指标](#)。

7.10 电气特征

对于 $V_S = (V+) - (V-) = 1.8V$ 至 $5.5V$ ($\pm 0.9V$ 至 $\pm 2.75V$) , $T_A = 25^\circ C$, $R_L = 10k\Omega$ (连接到 $V_S/2$) , 并且 $V_{CM} = V_{OUT} = V_S/2$ (除非另有说明)

参数	测试条件	最小值	典型值	最大值	单位
失调电压					
V_{OS} 输入失调电压	$V_S = 5V$		± 0.4	± 1.6	mV
	$V_S = 5V, T_A = -40^\circ C$ 至 $125^\circ C$			± 2	
dV_{OS}/dT V_{OS} 温漂	$T_A = -40^\circ C$ 至 $125^\circ C$		± 0.6		$\mu V/^\circ C$
PSRR 电源抑制比	$V_S = 1.8$ 至 $5.5V, V_{CM} = (V-)$	80	105		dB
输入电压范围					
V_{CM} 共模电压范围	无相位反向, 轨到轨输入	$(V-) - 0.1$		$(V+) + 0.1$	V
CMRR 共模抑制比	$V_S = 1.8V, (V-) - 0.1V < V_{CM} < (V+) - 1.4V,$ $T_A = -40^\circ C$ 至 $125^\circ C$		86		dB
	$V_S = 5.5V, (V-) - 0.1V < V_{CM} < (V+) - 1.4V,$ $T_A = -40^\circ C$ 至 $125^\circ C$		95		
	$V_S = 5.5V, (V-) - 0.1V < V_{CM} < (V+) + 0.1V,$ $T_A = -40^\circ C$ 至 $125^\circ C$	63	77		
	$V_S = 1.8V, (V-) - 0.1V < V_{CM} < (V+) + 0.1V,$ $T_A = -40^\circ C$ 至 $125^\circ C$		68		
输入偏置电流					
I_B 输入偏置电流	$V_S = 5V$		± 5		pA
I_{OS} 输入失调电流			± 2		pA
噪声					
E_n 输入电压噪声 (峰峰值)	$f = 0.1Hz$ 至 $10Hz, V_S = 5V$		4.7		μV_{PP}
e_n 输入电压噪声密度	$f = 1kHz, V_S = 5V$		30		nV/\sqrt{Hz}
	$f = 10kHz, V_S = 5V$		27		
i_n 输入电流噪声密度	$f = 1kHz, V_S = 5V$		23		fA/\sqrt{Hz}
输入电容					
C_{ID} 差分			1.5		pF
C_{IC} 共模			5		pF
开环增益					
A_{OL} 开环电压增益	$V_S = 5.5V, (V-) + 0.05V < V_O < (V+) - 0.05V,$ $R_L = 10k\Omega$	104	117		dB
	$V_S = 1.8V, (V-) + 0.04V < V_O < (V+) - 0.04V,$ $R_L = 10k\Omega$		100		
	$V_S = 1.8V, (V-) + 0.1V < V_O < (V+) - 0.1V,$ $R_L = 2k\Omega$		115		
	$V_S = 5.5V, (V-) + 0.15V < V_O < (V+) - 0.15V,$ $R_L = 2k\Omega$		130		
频率响应					
GBW 增益带宽积	$V_S = 5V$		1		MHz
ϕ_m 相位裕度	$V_S = 5.5V, G = 1$		78		$^\circ$
SR 压摆率	$V_S = 5V$		2		V/ μs
t_s 趋稳时间	精度达到 0.1%, $V_S = 5V, 2V$ 阶跃, $G = +1, C_L = 100pF$		2.5		μs
	精度达到 0.01%, $V_S = 5V, 2V$ 阶跃, $G = +1, C_L = 100pF$		3		
t_{OR} 过载恢复时间	$V_S = 5V, V_{IN} \times \text{增益} > V_S$		0.85		μs
THD+N 总谐波失真 + 噪声	$V_S = 5.5V, V_{CM} = 2.5V, V_O = 1V_{RMS}, G = +1,$ $f = 1kHz, 80kHz$ 测量 BW		0.004%		
输出					
V_O 相对于电源轨的电压输出摆幅	$V_S = 5.5V, R_L = 10k\Omega$		10	20	mV
	$V_S = 5.5V, R_L = 2k\Omega$		35	55	

7.10 电气特征 (continued)

对于 $V_S = (V+) - (V-) = 1.8V$ 至 $5.5V$ ($\pm 0.9V$ 至 $\pm 2.75V$) , $T_A = 25^\circ C$, $R_L = 10k\Omega$ (连接到 $V_S / 2$) , 并且 $V_{CM} = V_{OUT} = V_S / 2$ (除非另有说明)

参数	测试条件	最小值	典型值	最大值	单位
I_{sc} 短路电流	$V_S = 5.5V$		± 40		mA
Z_o 开环输出阻抗	$V_S = 5V, f = 1MHz$		1200		Ω

7.10 电气特征 (continued)

对于 $V_S = (V+) - (V-) = 1.8V$ 至 $5.5V$ ($\pm 0.9V$ 至 $\pm 2.75V$) , $T_A = 25^\circ C$, $R_L = 10k\Omega$ (连接到 $V_S/2$) , 并且 $V_{CM} = V_{OUT} = V_S/2$ (除非另有说明)

参数		测试条件		最小值	典型值	最大值	单位
电源							
V_S	额定电压范围			1.8 (± 0.9)		5.5 (± 2.75)	V
I_Q	每个放大器的静态电流	TLV9002、TLV9002S、 TLV9004、TLV9004S	$I_O = 0mA$, $V_S = 5.5V$		60	75	μA
		TLV9001、TLV9001S	$I_O = 0mA$, $V_S = 5.5V$		60	77	
		$I_O = 0mA$, $V_S = 5.5V$, $T_A = -40^\circ C$ 至 $125^\circ C$				85	
关断⁽¹⁾							
I_{QSD}	每个放大器的静态电流	$V_S = 1.8V$ 至 $5.5V$, 所有放大器为禁用状态 , $\overline{SHDN} = V_S^-$			0.5	1.5	μA
Z_{SHDN}	关断时的输出阻抗	$V_S = 1.8V$ 至 $5.5V$, 放大器为禁用状态			10 2		$G\Omega$ pF
	高电平电压关断阈值 (放大器为启用状态)	$V_S = 1.8V$ 至 $5.5V$			$(V-) + 0.9$	$(V-) + 1.1$	V
	低电平电压关断阈值 (放大器为禁用状态)	$V_S = 1.8V$ 至 $5.5V$			$(V-) + 0.2V$	$(V-) + 0.7V$	V
t_{ON}	放大器启用时间 (完全关断)	$V_S = 1.8V$ 至 $5.5V$, 完全关断 ; $G = 1$, $V_{OUT} = 0.9 \times V_S / 2$, R_L 连接到 V^-			70		μs
	放大器启用时间 (部分关断)	$V_S = 1.8V$ 至 $5.5V$, 部分关断 ; $G = 1$, $V_{OUT} = 0.9 \times V_S / 2$, R_L 连接到 V^-			50		
t_{OFF}	放大器禁用时间	$V_S = 1.8V$ 至 $5.5V$, $G = 1$, $V_{OUT} = 0.1 \times V_S / 2$, R_L 连接到 V^-			4		μs
	\overline{SHDN} 引脚输入偏置电流 (每个引脚)	$V_S = 1.8V$ 至 $5.5V$, $V+ \geq \overline{SHDN} \geq (V+) - 0.8V$			40		nA
		$V_S = 1.8V$ 至 $5.5V$, $V- \leq \overline{SHDN} \leq V- + 0.8V$			150		

(1) 由设计和特性指定 ; 未经生产测试。

7.11 典型特性

$T_A = 25^\circ\text{C}$ 时, $V_+ = 2.75\text{V}$, $V_- = -2.75\text{V}$, $R_L = 10\text{k}\Omega$ (连接到 $V_S/2$), $V_{CM} = V_S/2$, 并且 $V_{OUT} = V_S/2$ (除非另有说明)

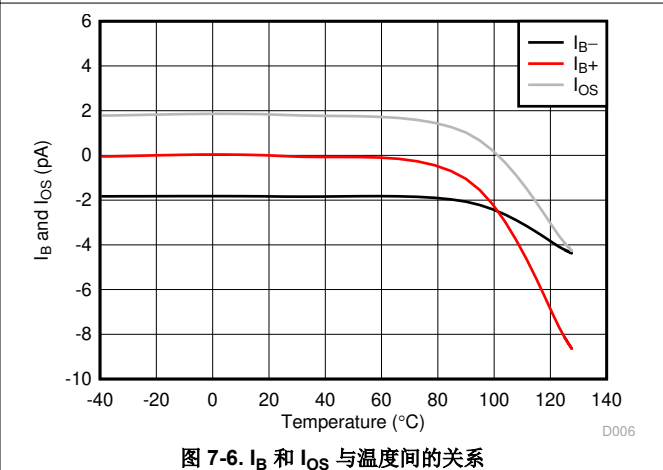
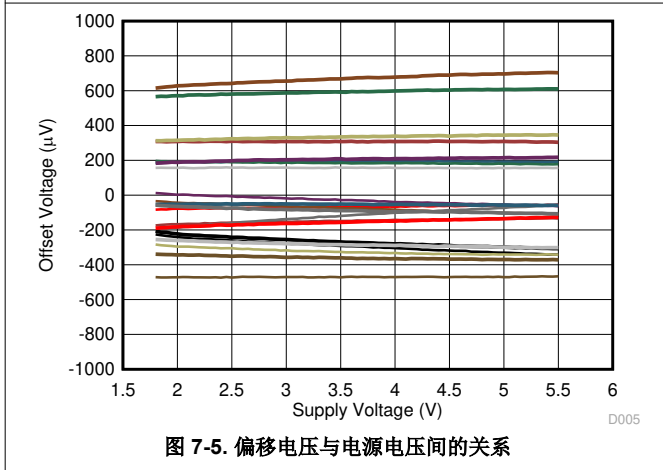
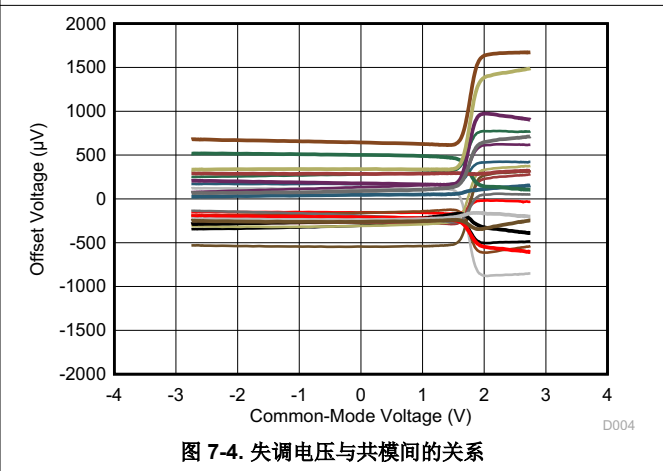
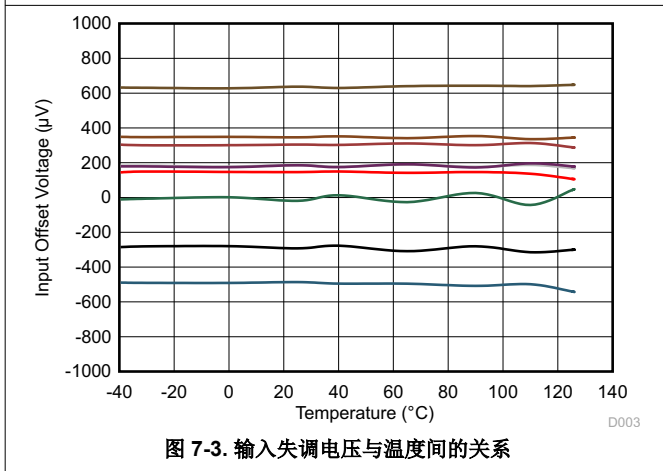
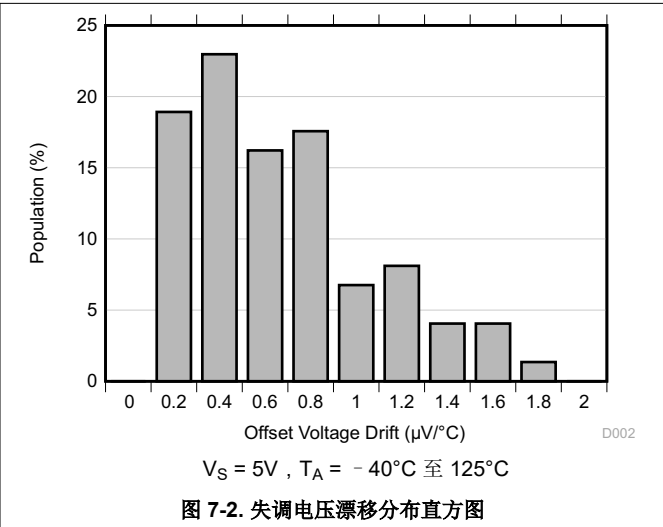
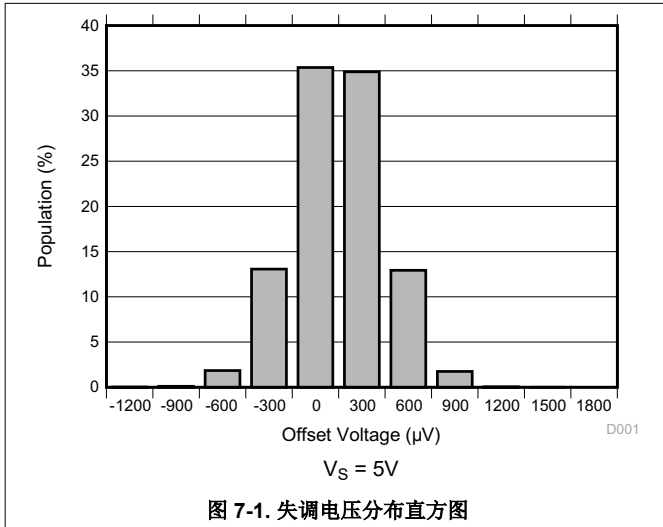

7.11 典型特性 (continued)

$T_A = 25^\circ\text{C}$ 时, $V_+ = 2.75\text{V}$, $V_- = -2.75\text{V}$, $R_L = 10\text{k}\Omega$ (连接到 $V_S/2$), $V_{CM} = V_S/2$, 并且 $V_{OUT} = V_S/2$ (除非另有说明)



图 7-7. I_B 和 I_{OS} 与共模电压间的关系



图 7-8. 开环增益与温度间的关系

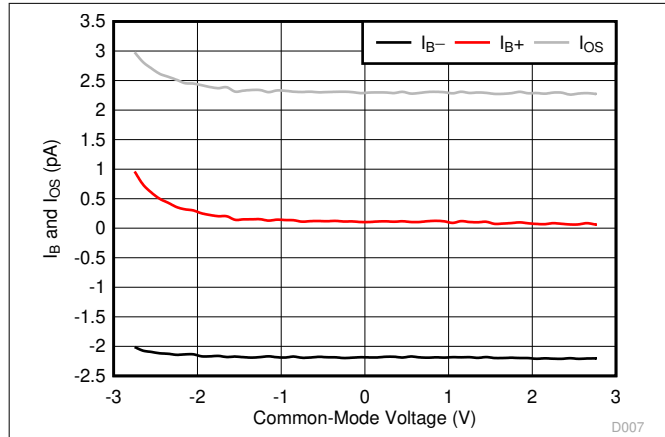

图 7-9. 开环增益和相位与频率间的关系

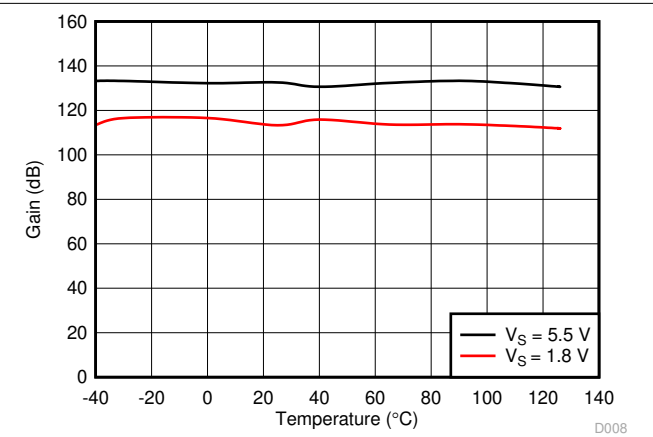

图 7-10. 开环增益与输出电压间的关系

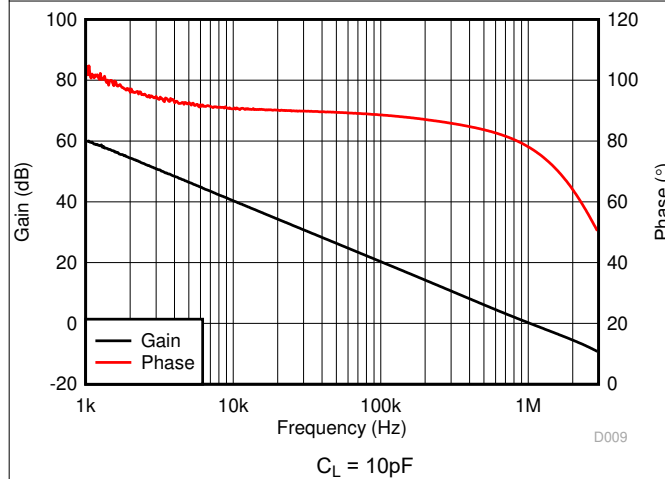

图 7-11. 闭环增益与频率间的关系

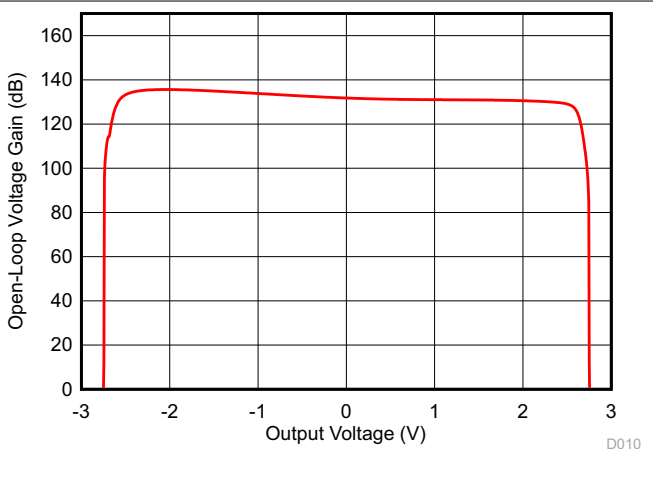

图 7-12. 输出电压与输出电流间的关系 (爪形)

7.11 典型特性 (continued)

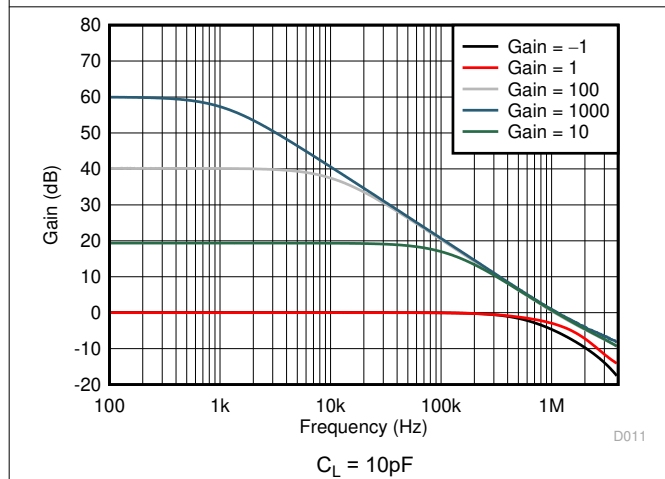
$T_A = 25^\circ\text{C}$ 时, $V_+ = 2.75\text{V}$, $V_- = -2.75\text{V}$, $R_L = 10\text{k}\Omega$ (连接到 $V_S/2$), $V_{CM} = V_S/2$, 并且 $V_{OUT} = V_S/2$ (除非另有说明)

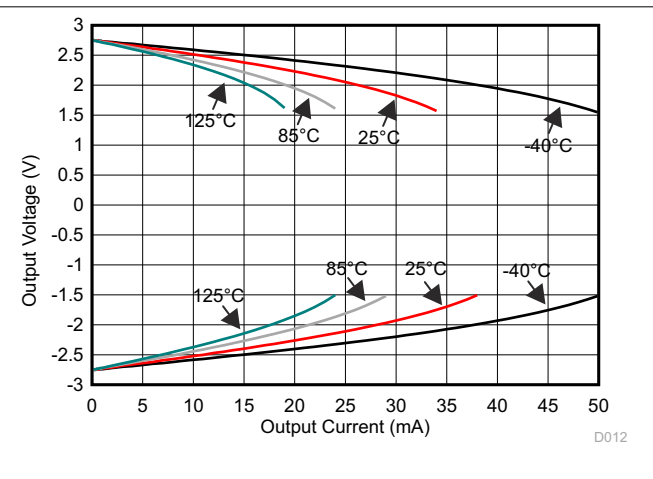

图 7-13. PSRR 与频率间的关系



图 7-14. 直流 PSRR 与温度间的关系

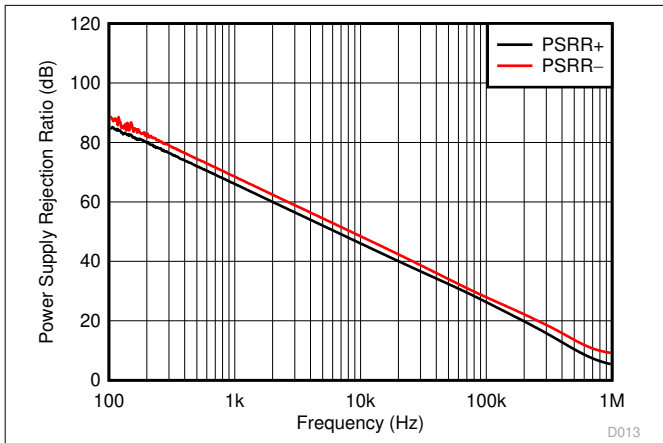

图 7-15. CMRR 与频率间的关系

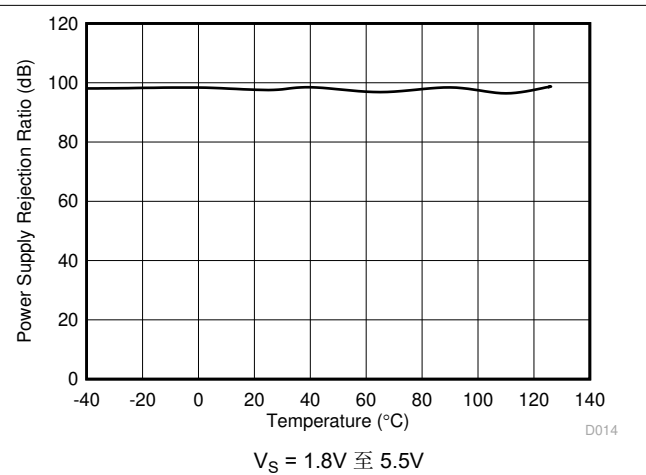

图 7-16. 直流 CMRR 与温度间的关系

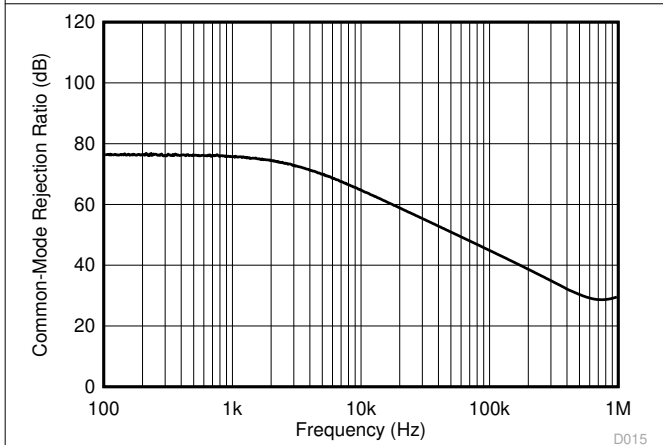

图 7-17. 0.1Hz 至 10Hz 集成电压噪声

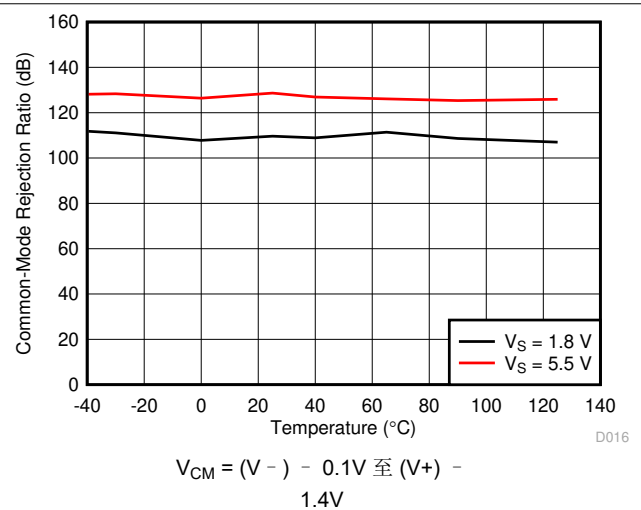

图 7-18. 输入电压噪声频谱密度

7.11 典型特性 (continued)

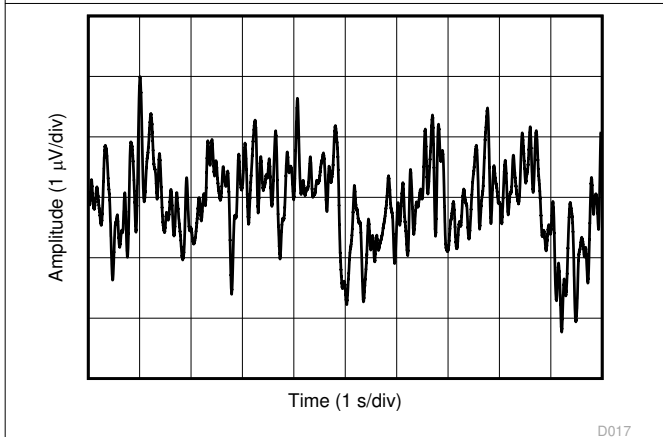
$T_A = 25^\circ\text{C}$ 时, $V_+ = 2.75\text{V}$, $V_- = -2.75\text{V}$, $R_L = 10\text{k}\Omega$ (连接到 $V_S/2$), $V_{CM} = V_S/2$, 并且 $V_{OUT} = V_S/2$ (除非另有说明)

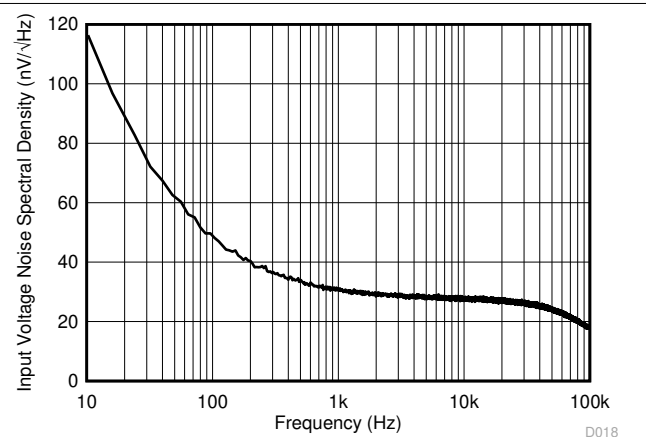
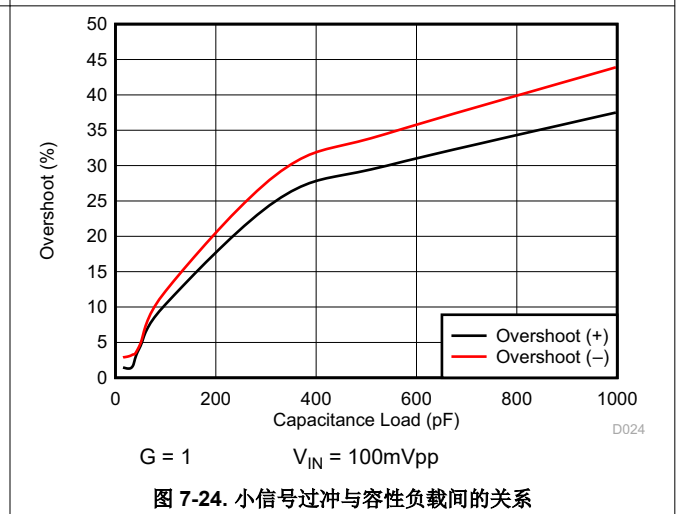
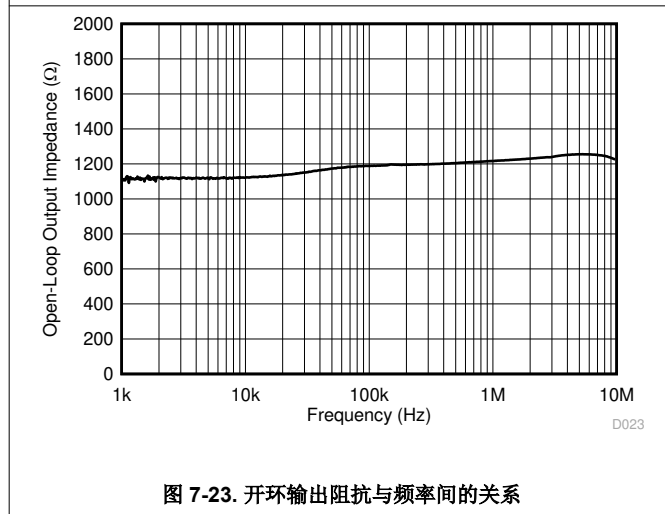

7.11 典型特性 (continued)

$T_A = 25^\circ\text{C}$ 时, $V_+ = 2.75\text{V}$, $V_- = -2.75\text{V}$, $R_L = 10\text{k}\Omega$ (连接到 $V_S/2$), $V_{CM} = V_S/2$, 并且 $V_{OUT} = V_S/2$ (除非另有说明)

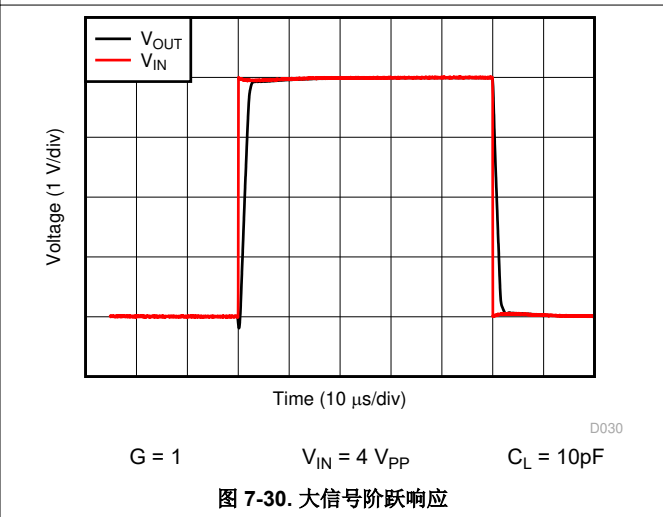
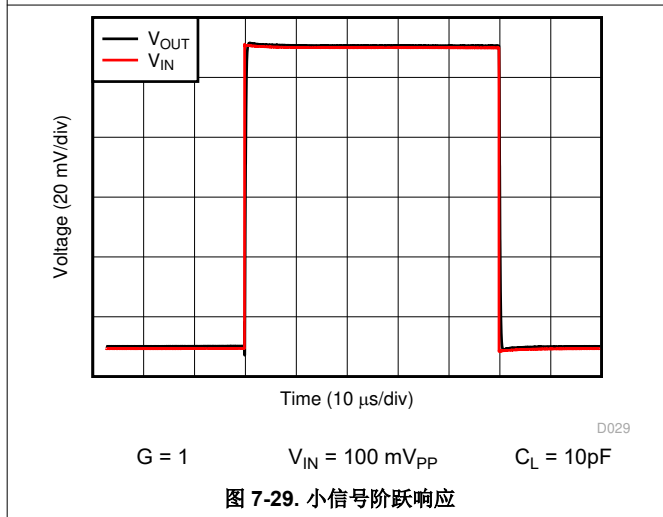
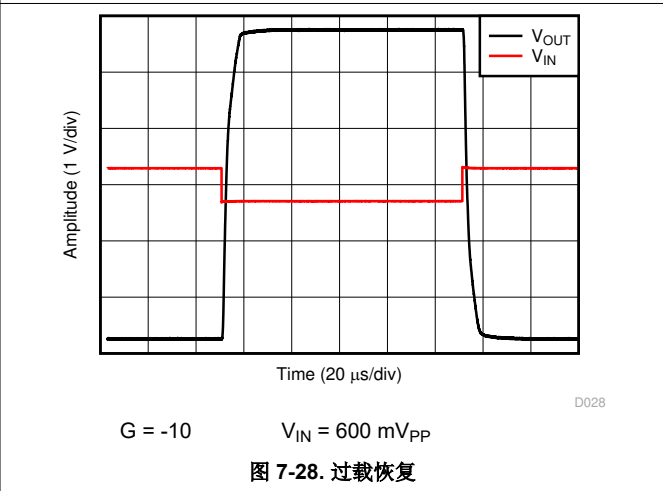
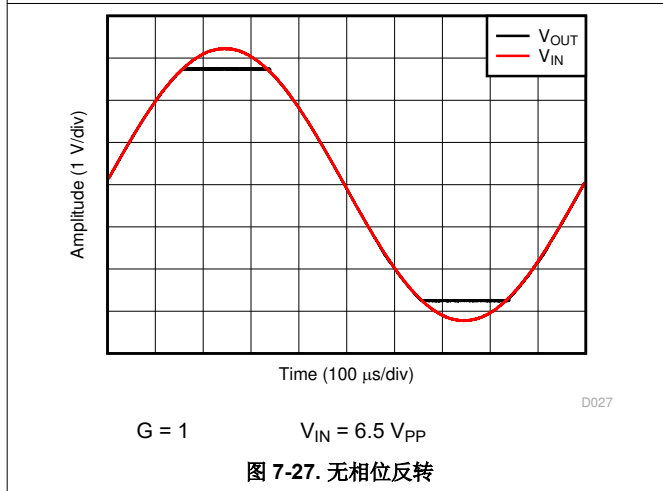
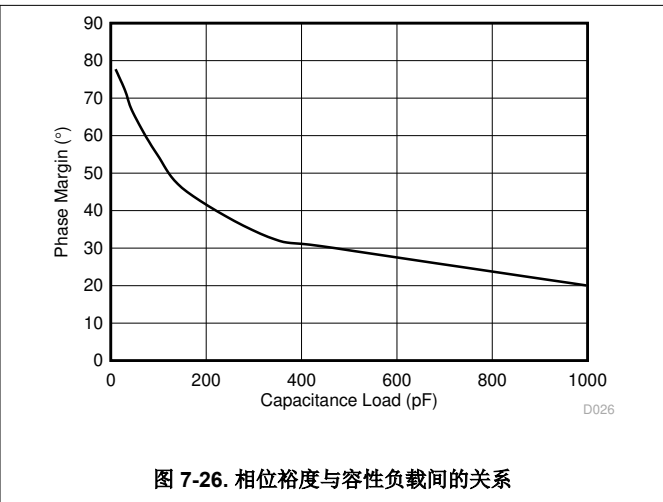

7.11 典型特性 (continued)

$T_A = 25^\circ\text{C}$ 时, $V_+ = 2.75\text{V}$, $V_- = -2.75\text{V}$, $R_L = 10\text{k}\Omega$ (连接到 $V_S/2$), $V_{CM} = V_S/2$, 并且 $V_{OUT} = V_S/2$ (除非另有说明)



图 7-31. 大信号建立时间 (负)



图 7-32. 大信号建立时间 (正)



图 7-33. 短路电流与温度间的关系

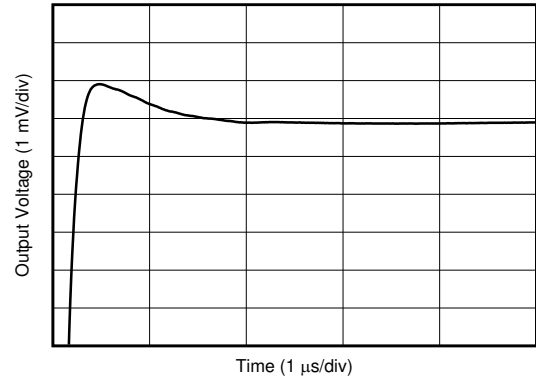

图 7-34. 最大输出电压与频率间的关系

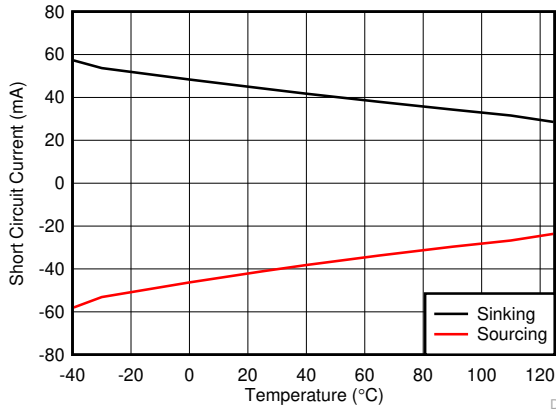

图 7-35. 以同相输入为基准的电磁干扰抑制比 (EMIRR+) 与频率间的关系

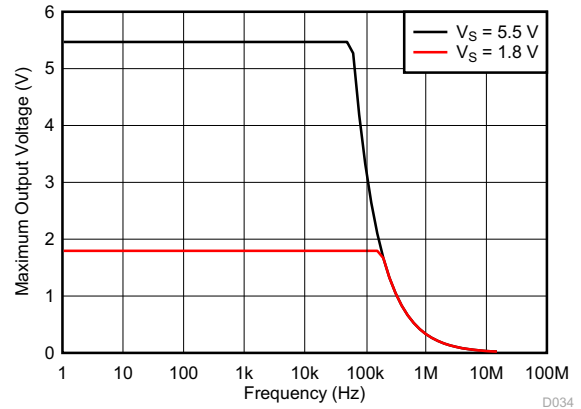

图 7-36. 通道分离

8 详细说明

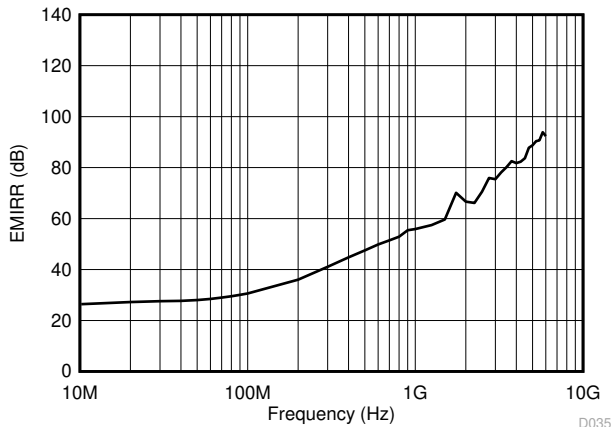
8.1 概述

TLV900x 是一系列低功率、轨对轨输入和输出运算放大器。这些器件的工作电压介于 1.8V 至 5.5V 之间，单位增益稳定，专为广泛的通用应用而设计。输入共模电压范围包括两个电源轨，并支持将 TLV900x 系列用于几乎任何单电源应用。轨对轨输入和输出摆动显著增加了动态范围，特别是在低电源应用中，使其适合驱动采样模数转换器 (ADC)。

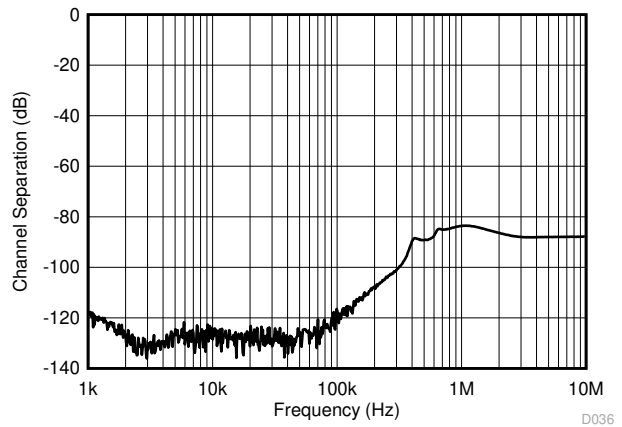
8.2 功能方框图

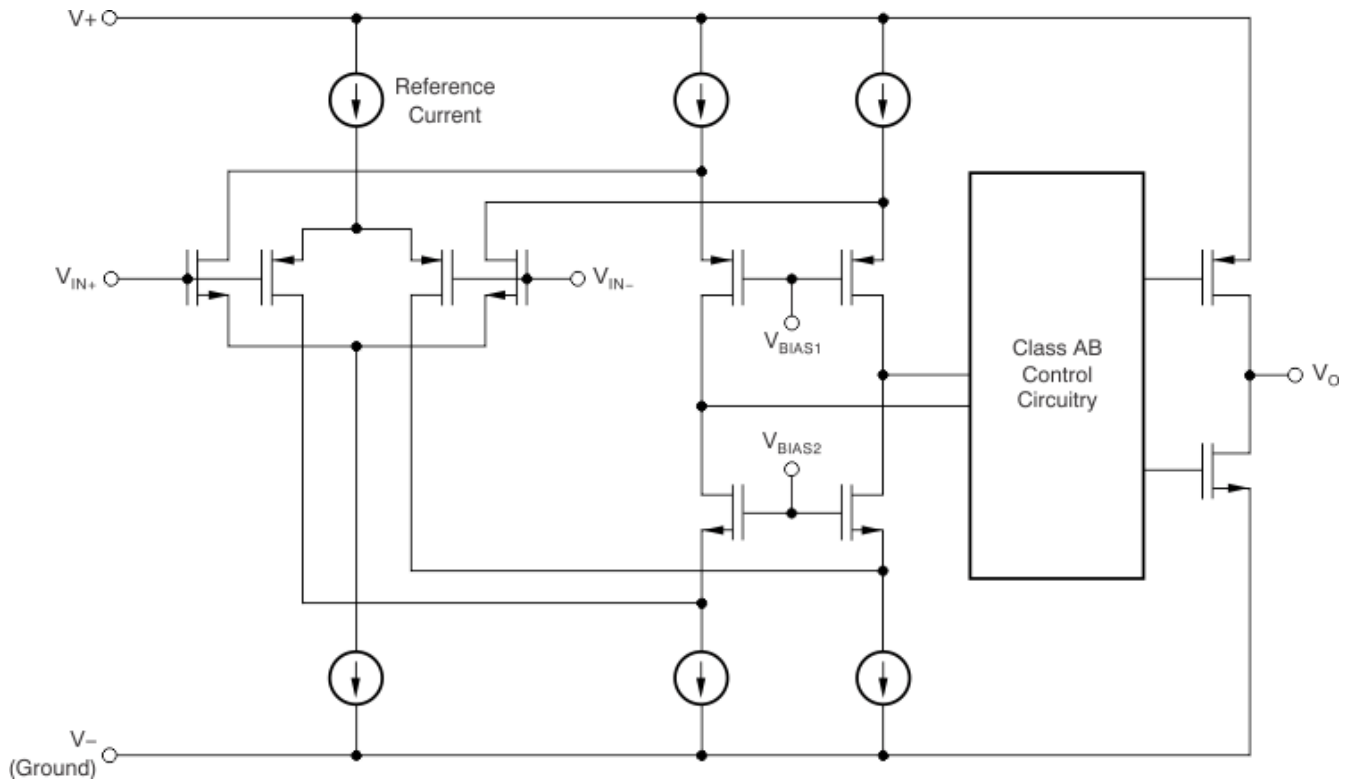

8.3 特性说明

8.3.1 工作电压

TLV900x 系列运算放大器适用于 1.8V 至 5.5V 的电压范围。此外，输入失调电压、静态电流、失调电流和短路电流等多种规格适用于 -40°C 至 125°C 的温度范围。参数随工作电压或温度而显著变化，如节 7.11 中所示。

8.3.2 轨到轨输入

TLV900x 系列的输入共模电压范围相对于电源轨向外扩展了 100mV，从而支持 1.8V 至 5.5V 的完整电源电压范围。此性能由一个互补输入级实现：一个 N 沟道输入差分对和一个 P 沟道差分对并联，如节 8.2 中所示。当输入电压靠近正轨（通常在 (V+) - 1.4V 到高于正电源电压 100mV 之间）时，N 沟道对有效；而当输入在低于负电源电压 100mV 到大约 (V+) - 1.4V 之间时，P 沟道对有效。通常当介于 (V+) - 1.2V 到 (V+) - 1V 之间的小切换区域内，两个通道对都会打开。此 100mV 转换区域可能会随工艺不同而发生变化，最高可达 100mV。因此，此转换区域（两个级都打开）在低端上的范围介于 (V+) - 1.4V 至 (V+) - 1.2V 之间，而在高端上的范围高达 (V+) - 1V 至 (V+) - 0.8V。在此转换区域内，与器件在该区域外运行相比，PSRR、CMRR、失调电压、温漂和 THD 等性能可能会下降。

8.3.3 轨到轨输出

TLV900x 系列设计为一种低功耗、低电压运算放大器，可提供强大的输出驱动能力。一个具有共源晶体管的 AB 类输出级可实现完全的轨到轨输出摆幅功能。对于 10kΩ 的阻性负载，无论施加的电源电压是多少，输出摆幅都在两个电源轨的 20 mV 范围内。不同的负载情况会改变放大器在靠近电源轨范围内摆动的能力。

8.3.4 EMI 抑制

TLV900x 采用集成电磁干扰 (EMI) 滤波来减少无线通信设备、混合使用模拟信号链和数字元件的高密度电路板等干扰源产生的 EMI 效应。通过电路设计技术可改进 EMI 抗扰度；TLV900x 受益于这些设计改进措施。德州仪器 (TI) 已经开发出在 10MHz 至 6GHz 宽频谱范围内准确测量和量化运算放大器抗扰度的功能。图 8-1 展示了对 TLV900x 执行此测试的结果。表 8-1 展示了 TLV900x 在实际应用中常见特定频率下的 EMIRR IN+ 值。运算放大器的 EMI 抑制比应用报告包含了与运算放大器相关的 EMIRR 性能主题，该报告可在 www.ti.com 上下载。



图 8-1. EMIRR 测试

表 8-1. TLV900x 在目标频率下的 EMIRR IN+

频率	应用或分配	EMIRR IN+
400MHz	移动无线广播、移动卫星、太空操作、气象、雷达、超高频 (UHF) 应用	59.5 dB
900MHz	全球移动通信系统 (GSM) 应用、无线电通信、导航、GPS (最高可达 1.6GHz)、GSM、航空移动通信及 UHF 应用	68.9 dB
1.8GHz	GSM 应用、个人移动通信、宽带、卫星和 L 波段 (1GHz 至 2GHz)	77.8 dB
2.4GHz	802.11b、802.11g、802.11n、蓝牙®、个人移动通信、工业、科学和医疗 (ISM) 无线频段、业余无线电通信和卫星、S 波段 (2GHz 至 4GHz)	78.0 dB

表 8-1. TLV900x 在目标频率下的 EMIRR IN+ (continued)

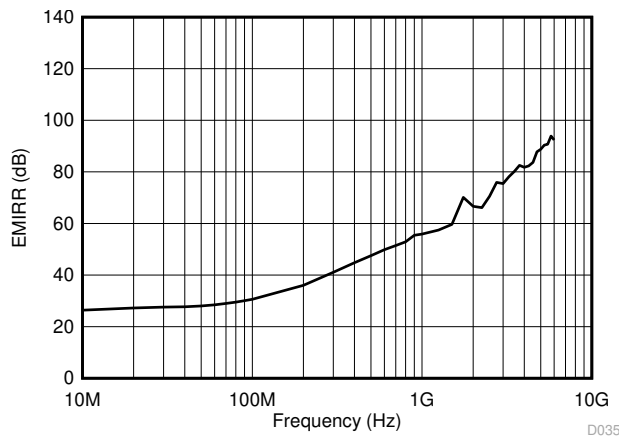
频率	应用或分配	EMIRR IN+
3.6GHz	无线电定位、航空通信和导航、卫星、移动通信、S 波段	88.8 dB

8.4 过载恢复

过载恢复定义为运算放大器输出从饱和状态恢复到线性状态所需的时间。当输出电压由于高输入电压或高增益而超过额定工作电压时，运算放大器的输出器件进入饱和区。器件进入饱和区后，输出器件中的电荷载体需要时间回到线性状态。当电荷载体回到线性状态时，器件开始以指定的压摆率进行转换。因此，传播延迟（过载情况下）等于过载恢复时间与转换时间之和。TLV900x 系列的过载恢复时间约为 850ns。

8.5 关断

TLV9001S、TLV9002S 和 TLV9004S 器件具有 $\overline{\text{SHDN}}$ 引脚，可禁用运算放大器，将其置于低功耗待机模式。在此模式下，运算放大器消耗的电流通常低于 $1\mu\text{A}$ 。 $\overline{\text{SHDN}}$ 引脚为低电平有效，这意味着当 $\overline{\text{SHDN}}$ 引脚的输入为有效逻辑低电平时启用关断模式。

$\overline{\text{SHDN}}$ 引脚以运算放大器的负电源电压为基准。关断特性的阈值在 620mV（典型值）左右，且不随电源电压的变化而变化。开关阈值中包含了迟滞，以确保顺畅的开关特性。为了确保最佳的关断行为，应通过有效逻辑信号驱动 $\overline{\text{SHDN}}$ 引脚。有效逻辑低电平被定义为 V^- 和 $V^- + 0.2\text{V}$ 之间的电压。有效逻辑高电平被定义为 $V^- + 1.2\text{V}$ 和 V^+ 之间的电压。关断引脚电路包括上拉电阻器，如果不驱动，上拉电阻器会固地将引脚电压拉至正电源轨。因此，若要启用放大器， $\overline{\text{SHDN}}$ 引脚应该保持悬空或被驱动至有效逻辑高电平。若要禁用放大器，必须将 $\overline{\text{SHDN}}$ 引脚驱动至有效逻辑低电平。虽然我们强烈建议将关断引脚连接到有效的高电压或低电压或者将其驱动，但我们已提供连接到 VCC 的上拉电阻器。 $\overline{\text{SHDN}}$ 引脚允许的最大电压为 $(V^+) + 0.5\text{V}$ 。超过此电压水平器件将损坏。

$\overline{\text{SHDN}}$ 引脚为高阻抗 CMOS 输入。双通道运算放大器版本是独立控制的，而四通道运算放大器版本是采用逻辑输入成对控制的。对于电池供电的应用，这种特性可用于大幅降低平均电流并延长电池使用寿命。所有通道全部关断时，启用时间为 $70\mu\text{s}$ ；禁用时间为 $4\mu\text{s}$ 。禁用时，输出呈现高阻抗状态。该架构允许将 TLV9002S 和 TLV9004S 作为门控放大器使用（或将器件输出多路复用到公共模拟输出总线上）。关断时间 (t_{OFF}) 取决于负载条件，并随负载电阻的增加而增加。为了确保在特定的关断时间内关断（禁用），指定的 $10\text{k}\Omega$ 负载需加载到中间电源 ($V_S/2$)。如果在没有负载的情况下使用 TLV9001S、TLV9002S 或 TLV9004S，则产生的关断时间会显著增加。

8.6 器件功能模式

TLV900x 系列拥有单功能模式。只要电源电压在 1.8V ($\pm 0.9\text{V}$) 和 5.5V ($\pm 2.75\text{V}$) 之间，这些器件就处于通电状态。

9 应用和实现

备注

以下应用部分中的信息不属于 TI 组件规范，TI 不担保其准确性和完整性。TI 的客户应负责确定各元件是否适用于其应用。客户应验证并测试其设计实现，以确认系统功能。

9.1 应用信息

TLV900x 系列低功耗轨对轨输入和输出运算放大器是专为便携式应用而设计的。这些器件的工作电压介于 1.8V 至 5.5V 之间，单位增益稳定，并且适合广泛的通用应用。AB 类输出级能够驱动连接至 $V+$ 和 $V-$ 之间任一点且小于或等于 $10k\Omega$ 的负载。输入共模电压范围包括两个电源轨，并支持将 TLV900x 器件用于多单电源应用。

9.2 典型应用

9.2.1 TLV900x 低侧电流感测应用

图 9-1 展示了低侧电流感测应用中配置的 TLV900x。



图 9-1. 低侧电流感测应用中的 TLV900x

9.2.1.1 设计要求

此设计的设计要求如下：

- 负载电流：0A 至 1A
- 输出电压：4.9V
- 最大分流电压：100mV

9.2.1.2 详细设计过程

图 9-1 中的电路传递函数如方程式 1 所示

$$V_{OUT} = I_{LOAD} \times R_{SHUNT} \times Gain \quad (1)$$

负载电流 (I_{LOAD}) 在分流电阻器 (R_{SHUNT}) 上产生压降。负载电流设置为 0A 至 1A。为了在最大负载电流下保持分流电压低于 100mV，使用方程式 2 展示了最大分流电阻。

$$R_{SHUNT} = \frac{V_{SHUNT_MAX}}{I_{LOAD_MAX}} = \frac{100mV}{1A} = 100m\Omega \quad (2)$$

使用方程式 2 计算出的 R_{SHUNT} 为 100m Ω 。由 I_{LOAD} 和 R_{SHUNT} 产生的电压降被 TLV900x 放大，以产生大约 0V 到 4.9V 的输出电压。使用方程式 3 计算 TLV900x 产生必要输出电压所需的增益。

$$Gain = \frac{(V_{OUT_MAX} - V_{OUT_MIN})}{(V_{IN_MAX} - V_{IN_MIN})} \quad (3)$$

使用方程式 3 计算出的所需增益为 49V/V，该值由电阻器 R_F 和 R_G 设置。方程式 4 用于调整 R_F 和 R_G 电阻器的大小，将 TLV900x 的增益设置为 49V/V。

$$Gain = 1 + \frac{(R_F)}{(R_G)} \quad (4)$$

选择 R_F 为 57.6k Ω ， R_G 为 1.2k Ω 可提供等于 49V/V 的组合。图 9-2 展示了图 9-1 中所示电路测得的传递函数。请注意，增益只是反馈和增益电阻器的函数。通过改变电阻器的比率来调整该增益，并且实际电阻器值由设计人员想要建立的阻抗水平确定。阻抗水平决定了电流损耗、杂散电容的影响以及其他一些行为。并不存在适用于每个系统的最佳阻抗选择，您必须选择适合您的系统参数的阻抗。

9.2.1.3 应用曲线



图 9-2. 低侧电流感测传递函数

9.2.2 单电源光电二极管放大器

光电二极管在许多应用中用于将光信号转换为电信号。通过光电二极管的电流与吸收的光子能量成正比，通常在几百皮安到几十微安的范围内。跨阻抗配置中的放大器通常用于将低电平光电二极管电流转换为电压信号以在 MCU 中处理。图 9-3 中显示的电路是一个使用 TLV9002 的单电源光电二极管放大器电路的示例。

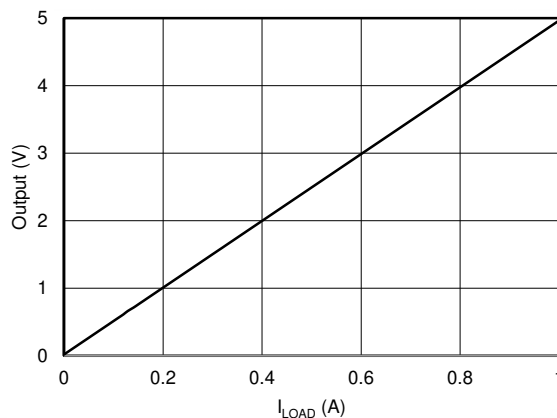

图 9-3. 单电源光电二极管放大器电路

9.2.2.1 设计要求

此设计的设计要求如下：

- 电源电压：3.3V
- 输入：0μA 至 10μA
- 输出：0.1 V 至 3.2 V
- 带宽：50kHz

9.2.2.2 详细设计过程

方程式 5 中定义了输出电压 (V_{OUT})、输入电流 (I_{IN}) 和参考电压 (V_{REF}) 之间的传递函数。

$$V_{OUT} = I_{IN} \times R_F + V_{REF} \quad (5)$$

其中：

$$V_{REF} = V_+ \times \left(\frac{R_1 \times R_2}{R_1 + R_2} \right) \quad (6)$$

通过设置 R1 和 R2 以满足方程式 7 中计算的所需比率，将 V_{REF} 设置为 100mV 以满足最小输出电压电平。

$$\frac{V_{REF}}{V_+} = \frac{0.1 \text{ V}}{3.3 \text{ V}} = 0.0303 \quad (7)$$

满足该比率的最接近电阻比率将 R1 设置为 11.5kΩ，将 R2 设置为 357Ω。

可以基于输入电流和期望的输出电压来计算所需的反馈电阻。

$$R_F = \frac{V_{OUT} - V_{REF}}{I_{IN}} = \frac{3.2 \text{ V} - 0.1 \text{ V}}{10 \mu\text{A}} = 310 \frac{\text{kV}}{\text{A}} \approx 309 \text{ k}\Omega \quad (8)$$

使用方程式 9，基于 R_F 和所需的 -3-dB 带宽 (f_{-3dB}) 计算反馈电容器的值。

$$C_F = \frac{1}{2 \times \pi \times R_F \times f_{-3dB}} = \frac{1}{2 \times \pi \times 309 \text{ k}\Omega \times 50 \text{ kHz}} = 10.3 \text{ pF} \approx 10 \text{ pF} \quad (9)$$

此应用所需的最小运算放大器带宽基于 R_F 、 C_F 的值，以及 TLV9002 INx - 引脚上的电容，该电容等于光电二极管并联电容 (CPD)、共模输入电容 (CCM) 和差分输入电容 (CD) 之和，如方程式 10 所示。

$$C_{IN} = C_{PD} + C_{CM} + C_D = 47 \text{ pF} + 5 \text{ pF} + 1 \text{ pF} = 53 \text{ pF} \quad (10)$$

最小运算放大器带宽在方程式 11 中计算。

$$f_{-BGW} \geq \frac{C_{IN} + C_F}{2 \times \pi \times R_F \times C_F^2} \geq 324 \text{ kHz} \quad (11)$$

TLV900x 的 1MHz 带宽满足最低带宽要求，并在此应用配置中保持稳定。

9.2.2.3 应用曲线

光电二极管放大器电路的测量电流到电压传递函数如图 9-4 所示。光电二极管放大器电路的测量性能如图 9-5 所示。



图 9-4. 光电二极管放大器电路交流增益结果



图 9-5. 光电二极管放大器电路直流结果

10 电源相关建议

TLV900x 系列的额定工作电压范围为 1.8V 至 5.5V ($\pm 0.9\text{V}$ 至 $\pm 2.75\text{V}$) ; 多种规格适用于 -40°C 至 125°C 的温度范围。节 7.11 中介绍了可能会随工作电压或温度而显著变化的参数。

CAUTION

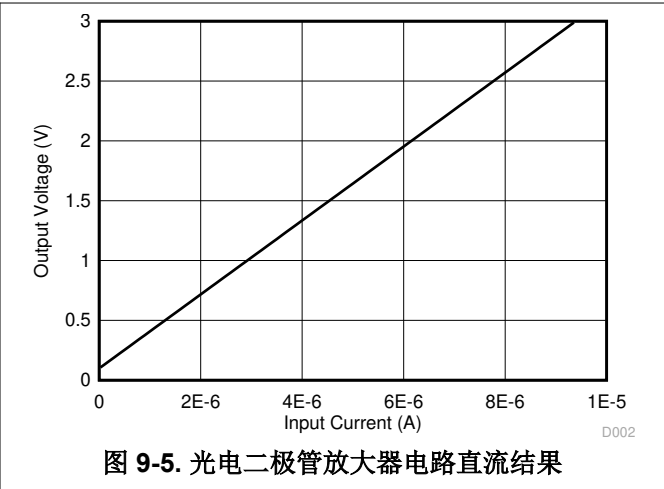
电源电压超过 6V 可能会对器件造成损坏；请参阅节 7.1。

将 $0.1\mu\text{F}$ 旁路电容器置于电源引脚附近，以减少来自高噪声电源或高阻抗电源的耦合误差。有关旁路电容器放置的更多详细信息，请参阅节 11.1。

10.1 输入和 ESD 保护

TLV900x 系列在所有引脚上均整合了内部 ESD 保护电路。对于输入和输出引脚，这种保护主要包括输入和电源引脚之间连接的导流二极管。只要电流不超过 10mA ，这些 ESD 保护二极管就能提供电路内输入过驱保护。图 10-1 显示了如何通过将串联输入电阻器添加到被驱动的输入端来限制输入电流。添加的电阻器会增加放大器输入端的热噪声，在对噪声敏感的应用中，该值必须保持在最低。



图 10-1. 输入电流保护

11 布局

11.1 布局指南

为了使器件具有最佳运行性能，请使用良好的印刷电路板 (PCB) 布局实践，包括：

- 噪声可以通过电路板的电源连接传播到模拟电路中，并传播到运算放大器本身的电源引脚。旁路电容器用于通过提供低阻抗接地路径来降低耦合噪声。
 - 在每个电源引脚和接地端之间连接低 ESR 0.1 μ F 陶瓷旁路电容器，放置位置尽量靠近器件。从 V+ 到接地端的单个旁路电容器足以满足单电源应用的需求。
- 将电路中模拟和数字部分单独接地是最简单和最有效的噪声抑制方法之一。多层 PCB 上的一层或多层通常专门用于作为接地平面。接地层有助于散热和降低电磁干扰 (EMI) 噪声拾取。请小心地对数字接地和模拟接地进行物理隔离，同时应注意接地电流。
- 为了减少寄生耦合，请让输入走线尽可能远离电源或输出走线。如果这些走线不能保持分开，则以 90 度角穿过敏感走线比平行于噪声走线运行走线要好得多。
- 外部元件的位置应尽量靠近器件，如图 11-2 中所示。使 R_F 和 R_G 接近反相输入可最大限度地减小寄生电容。
- 尽可能缩短输入走线。切记，输入走线是电路中最敏感的部分。
- 考虑在关键走线周围设定驱动型低阻抗保护环。这样可显著减少附近不同电势下的走线所产生的泄漏电流。
- 为获得最佳性能，建议在组装 PCB 板后进行清洗。
- 任何精密集成电路都可能因湿气渗入塑料封装中而出现性能变化。请遵循所有的 PCB 水清洁流程，建议将 PCB 组装烘干，以去除清洗时渗入器件封装中的湿气。大多数情形下，清洗后在 85°C 下低温烘干 30 分钟即可。

11.2 布局示例



图 11-1. 原理图表示



图 11-2. 布局示例

12 器件和文档支持

12.1 文档支持

12.1.1 相关文档

请参阅如下相关文档：

- 德州仪器 (TI), [运算放大器的 EMI 抑制比](#)

12.2 接收文档更新通知

要接收文档更新通知，请导航至 ti.com 上的器件产品文件夹。点击 [订阅更新](#) 进行注册，即可每周接收产品信息更改摘要。有关更改的详细信息，请查看任何已修订文档中包含的修订历史记录。

12.3 支持资源

[TI E2E™ 支持论坛](#) 是工程师的重要参考资料，可直接从专家获得快速、经过验证的解答和设计帮助。搜索现有解答或提出自己的问题可获得所需的快速设计帮助。

链接的内容由各个贡献者“按原样”提供。这些内容并不构成 TI 技术规范，并且不一定反映 TI 的观点；请参阅 TI 的 [《使用条款》](#)。

12.4 商标

TI E2E™ is a trademark of Texas Instruments.

蓝牙® is a registered trademark of Bluetooth SIG, Inc.

所有商标均为其各自所有者的财产。

12.5 Electrostatic Discharge Caution



This integrated circuit can be damaged by ESD. Texas Instruments recommends that all integrated circuits be handled with appropriate precautions. Failure to observe proper handling and installation procedures can cause damage.

ESD damage can range from subtle performance degradation to complete device failure. Precision integrated circuits may be more susceptible to damage because very small parametric changes could cause the device not to meet its published specifications.

12.6 术语表

TI 术语表

本术语表列出并解释了术语、首字母缩略词和定义。

13 机械、封装和可订购信息

下述页面包含机械、封装和订购信息。这些信息是指定器件的最新可用数据。数据如有变更，恕不另行通知，且不会对此文档进行修订。如需获取此数据表的浏览器版本，请查看左侧的导航面板。

PACKAGING INFORMATION

Orderable part number	Status (1)	Material type (2)	Package Pins	Package qty Carrier	RoHS (3)	Lead finish/ Ball material (4)	MSL rating/ Peak reflow (5)	Op temp (°C)	Part marking (6)
TLV9001IDBVR	Active	Production	SOT-23 (DBV) 5	3000 LARGE T&R	Yes	NIPDAU SN	Level-1-260C-UNLIM	-40 to 125	1OGF
TLV9001IDBVR.A	Active	Production	SOT-23 (DBV) 5	3000 LARGE T&R	Yes	SN	Level-1-260C-UNLIM	-40 to 125	1OGF
TLV9001IDCKR	Active	Production	SC70 (DCK) 5	3000 LARGE T&R	Yes	SN	Level-2-260C-1 YEAR	-40 to 125	1BZ
TLV9001IDCKR.A	Active	Production	SC70 (DCK) 5	3000 LARGE T&R	Yes	SN	Level-2-260C-1 YEAR	-40 to 125	1BZ
TLV9001IDPWR	Active	Production	X2SON (DPW) 5	3000 LARGE T&R	Yes	NIPDAUAG	Level-2-260C-1 YEAR	-40 to 125	DF
TLV9001IDPWR.A	Active	Production	X2SON (DPW) 5	3000 LARGE T&R	Yes	NIPDAUAG	Level-2-260C-1 YEAR	-40 to 125	DF
TLV9001SIDBVR	Active	Production	SOT-23 (DBV) 6	3000 LARGE T&R	Yes	NIPDAU SN	Level-1-260C-UNLIM	-40 to 125	1OJF
TLV9001SIDBVR.A	Active	Production	SOT-23 (DBV) 6	3000 LARGE T&R	Yes	NIPDAU	Level-1-260C-UNLIM	-40 to 125	1OJF
TLV9001SIDBVRG4	Active	Production	SOT-23 (DBV) 6	3000 LARGE T&R	Yes	NIPDAU	Level-1-260C-UNLIM	-40 to 125	1OJF
TLV9001SIDBVRG4.A	Active	Production	SOT-23 (DBV) 6	3000 LARGE T&R	Yes	NIPDAU	Level-1-260C-UNLIM	-40 to 125	1OJF
TLV9001SIDCKR	Active	Production	SC70 (DCK) 6	3000 LARGE T&R	Yes	SN	Level-2-260C-1 YEAR	-40 to 125	1F8
TLV9001SIDCKR.A	Active	Production	SC70 (DCK) 6	3000 LARGE T&R	Yes	SN	Level-2-260C-1 YEAR	-40 to 125	1F8
TLV9001TIDCKR	Active	Production	SC70 (DCK) 5	3000 LARGE T&R	Yes	SN	Level-2-260C-1 YEAR	-40 to 125	1D6
TLV9001TIDCKR.A	Active	Production	SC70 (DCK) 5	3000 LARGE T&R	Yes	SN	Level-2-260C-1 YEAR	-40 to 125	1D6
TLV9001UIDBVR	Active	Production	SOT-23 (DBV) 5	3000 LARGE T&R	Yes	NIPDAU SN	Level-1-260C-UNLIM	-40 to 125	1ODF
TLV9001UIDBVR.A	Active	Production	SOT-23 (DBV) 5	3000 LARGE T&R	Yes	NIPDAU	Level-1-260C-UNLIM	-40 to 125	1ODF
TLV9001ZIDPWR	Active	Production	X2SON (DPW) 5	3000 LARGE T&R	Yes	NIPDAU NIPDAUAG	Level-1-260C-UNLIM	-40 to 125	(D, DF)
TLV9001ZIDPWR.A	Active	Production	X2SON (DPW) 5	3000 LARGE T&R	Yes	NIPDAU	Level-1-260C-UNLIM	-40 to 125	(D, DF)
TLV9002IDDFR	Active	Production	SOT-23-THIN (DDF) 8	3000 LARGE T&R	Yes	NIPDAU	Level-1-260C-UNLIM	-40 to 125	T902
TLV9002IDDFR.A	Active	Production	SOT-23-THIN (DDF) 8	3000 LARGE T&R	Yes	NIPDAU	Level-1-260C-UNLIM	-40 to 125	T902
TLV9002IDDFRG4	Active	Production	SOT-23-THIN (DDF) 8	3000 LARGE T&R	Yes	NIPDAU	Level-1-260C-UNLIM	-40 to 125	T902
TLV9002IDDFRG4.A	Active	Production	SOT-23-THIN (DDF) 8	3000 LARGE T&R	Yes	NIPDAU	Level-1-260C-UNLIM	-40 to 125	T902
TLV9002IDGKR	Active	Production	VSSOP (DGK) 8	2500 LARGE T&R	Yes	NIPDAU SN	Level-2-260C-1 YEAR	-40 to 125	(1GNX, OBBI)
TLV9002IDGKR.A	Active	Production	VSSOP (DGK) 8	2500 LARGE T&R	Yes	NIPDAU	Level-2-260C-1 YEAR	-40 to 125	(1GNX, OBBI)
TLV9002IDGKRG4	Active	Production	VSSOP (DGK) 8	2500 LARGE T&R	Yes	NIPDAU	Level-2-260C-1 YEAR	-40 to 125	1GNX
TLV9002IDGKRG4.A	Active	Production	VSSOP (DGK) 8	2500 LARGE T&R	Yes	NIPDAU	Level-2-260C-1 YEAR	-40 to 125	1GNX
TLV9002IDGKT	Active	Production	VSSOP (DGK) 8	250 SMALL T&R	Yes	NIPDAU SN NIPDAUAG	Level-2-260C-1 YEAR	-40 to 125	(1GNX, OBBI)
TLV9002IDGKT.A	Active	Production	VSSOP (DGK) 8	250 SMALL T&R	Yes	NIPDAU	Level-2-260C-1 YEAR	-40 to 125	(1GNX, OBBI)

Orderable part number	Status (1)	Material type (2)	Package Pins	Package qty Carrier	RoHS (3)	Lead finish/ Ball material (4)	MSL rating/ Peak reflow (5)	Op temp (°C)	Part marking (6)
TLV9002IDR	Active	Production	SOIC (D) 8	2500 LARGE T&R	Yes	NIPDAU	Level-1-260C-UNLIM	-40 to 125	TL9002
TLV9002IDR.A	Active	Production	SOIC (D) 8	2500 LARGE T&R	Yes	NIPDAU	Level-1-260C-UNLIM	-40 to 125	TL9002
TLV9002IDRG4	Active	Production	SOIC (D) 8	2500 LARGE T&R	Yes	NIPDAU	Level-1-260C-UNLIM	-40 to 125	TL9002
TLV9002IDRG4.A	Active	Production	SOIC (D) 8	2500 LARGE T&R	Yes	NIPDAU	Level-1-260C-UNLIM	-40 to 125	TL9002
TLV9002IDSGR	Active	Production	WSON (DSG) 8	3000 LARGE T&R	Yes	NIPDAU	Level-1-260C-UNLIM	-40 to 125	1GMH
TLV9002IDSGR.A	Active	Production	WSON (DSG) 8	3000 LARGE T&R	Yes	NIPDAU	Level-1-260C-UNLIM	-40 to 125	1GMH
TLV9002IDSGRG4	Active	Production	WSON (DSG) 8	3000 LARGE T&R	Yes	NIPDAU	Level-1-260C-UNLIM	-40 to 125	1GMH
TLV9002IDSGRG4.A	Active	Production	WSON (DSG) 8	3000 LARGE T&R	Yes	NIPDAU	Level-1-260C-UNLIM	-40 to 125	1GMH
TLV9002IDSGT	Active	Production	WSON (DSG) 8	250 SMALL T&R	Yes	NIPDAU	Level-1-260C-UNLIM	-40 to 125	1GMH
TLV9002IDSGT.A	Active	Production	WSON (DSG) 8	250 SMALL T&R	Yes	NIPDAU	Level-1-260C-UNLIM	-40 to 125	1GMH
TLV9002IPWR	Active	Production	TSSOP (PW) 8	2000 LARGE T&R	Yes	NIPDAU SN	Level-2-260C-1 YEAR	-40 to 125	9002
TLV9002IPWR.A	Active	Production	TSSOP (PW) 8	2000 LARGE T&R	Yes	SN	Level-2-260C-1 YEAR	-40 to 125	9002
TLV9002SIDGSR	Active	Production	VSSOP (DGS) 10	2500 LARGE T&R	Yes	NIPDAU NIPDAUAG	Level-2-260C-1 YEAR	-40 to 125	1GDX
TLV9002SIDGSR.A	Active	Production	VSSOP (DGS) 10	2500 LARGE T&R	Yes	NIPDAUAG	Level-2-260C-1 YEAR	-40 to 125	1GDX
TLV9002SIRUGR	Active	Production	X2QFN (RUG) 10	3000 LARGE T&R	Yes	NIPDAUAG	Level-2-260C-1 YEAR	-40 to 125	ENF
TLV9002SIRUGR.A	Active	Production	X2QFN (RUG) 10	3000 LARGE T&R	Yes	NIPDAUAG	Level-2-260C-1 YEAR	-40 to 125	ENF
TLV9002SIYCKR	Active	Production	DSBGA (YCK) 9	3000 LARGE T&R	Yes	SNAGCU	Level-1-260C-UNLIM	-40 to 125	JK
TLV9002SIYCKR.A	Active	Production	DSBGA (YCK) 9	3000 LARGE T&R	Yes	SNAGCU	Level-1-260C-UNLIM	-40 to 125	JK
TLV9004IDR	Active	Production	SOIC (D) 14	2500 LARGE T&R	Yes	NIPDAU	Level-2-260C-1 YEAR	-40 to 125	TLV9004
TLV9004IDR.A	Active	Production	SOIC (D) 14	2500 LARGE T&R	Yes	NIPDAU	Level-2-260C-1 YEAR	-40 to 125	TLV9004
TLV9004IDRG4	Active	Production	SOIC (D) 14	2500 LARGE T&R	Yes	NIPDAU	Level-1-260C-UNLIM	-40 to 125	TLV9004
TLV9004IDRG4.A	Active	Production	SOIC (D) 14	2500 LARGE T&R	Yes	NIPDAU	Level-1-260C-UNLIM	-40 to 125	TLV9004
TLV9004IDYYR	Active	Production	SOT-23-THIN (DYY) 14	3000 LARGE T&R	Yes	NIPDAU	Level-1-260C-UNLIM	-40 to 125	TLV9004I
TLV9004IDYYR.A	Active	Production	SOT-23-THIN (DYY) 14	3000 LARGE T&R	Yes	NIPDAU	Level-1-260C-UNLIM	-40 to 125	TLV9004I
TLV9004IPWR	Active	Production	TSSOP (PW) 14	2000 LARGE T&R	Yes	NIPDAU SN	Level-1-260C-UNLIM	-40 to 125	TLV9004
TLV9004IPWR.A	Active	Production	TSSOP (PW) 14	2000 LARGE T&R	Yes	NIPDAU	Level-1-260C-UNLIM	-40 to 125	TLV9004
TLV9004IRTER	Active	Production	WQFN (RTE) 16	3000 LARGE T&R	Yes	NIPDAU	Level-1-260C-UNLIM	-40 to 125	T9004
TLV9004IRTER.A	Active	Production	WQFN (RTE) 16	3000 LARGE T&R	Yes	NIPDAU	Level-1-260C-UNLIM	-40 to 125	T9004
TLV9004IRUCR	Active	Production	QFN (RUC) 14	3000 LARGE T&R	Yes	NIPDAU	Level-2-260C-1 YEAR	-40 to 125	1DC

Orderable part number	Status (1)	Material type (2)	Package Pins	Package qty Carrier	RoHS (3)	Lead finish/ Ball material (4)	MSL rating/ Peak reflow (5)	Op temp (°C)	Part marking (6)
TLV9004IRUCR.A	Active	Production	QFN (RUC) 14	3000 LARGE T&R	Yes	NIPDAU	Level-2-260C-1 YEAR	-40 to 125	1DC
TLV9004IRUCRG4	Active	Production	QFN (RUC) 14	3000 LARGE T&R	Yes	NIPDAU	Level-2-260C-1 YEAR	-40 to 125	1DC
TLV9004IRUCRG4.A	Active	Production	QFN (RUC) 14	3000 LARGE T&R	Yes	NIPDAU	Level-2-260C-1 YEAR	-40 to 125	1DC
TLV9004SIRTER	Active	Production	WQFN (RTE) 16	3000 LARGE T&R	Yes	SN	Level-1-260C-UNLIM	-40 to 125	T9004S
TLV9004SIRTER.A	Active	Production	WQFN (RTE) 16	3000 LARGE T&R	Yes	SN	Level-1-260C-UNLIM	-40 to 125	T9004S

(1) **Status:** For more details on status, see our [product life cycle](#).

(2) **Material type:** When designated, preproduction parts are prototypes/experimental devices, and are not yet approved or released for full production. Testing and final process, including without limitation quality assurance, reliability performance testing, and/or process qualification, may not yet be complete, and this item is subject to further changes or possible discontinuation. If available for ordering, purchases will be subject to an additional waiver at checkout, and are intended for early internal evaluation purposes only. These items are sold without warranties of any kind.

(3) **RoHS values:** Yes, No, RoHS Exempt. See the [TI RoHS Statement](#) for additional information and value definition.

(4) **Lead finish/Ball material:** Parts may have multiple material finish options. Finish options are separated by a vertical ruled line. Lead finish/Ball material values may wrap to two lines if the finish value exceeds the maximum column width.

(5) **MSL rating/Peak reflow:** The moisture sensitivity level ratings and peak solder (reflow) temperatures. In the event that a part has multiple moisture sensitivity ratings, only the lowest level per JEDEC standards is shown. Refer to the shipping label for the actual reflow temperature that will be used to mount the part to the printed circuit board.

(6) **Part marking:** There may be an additional marking, which relates to the logo, the lot trace code information, or the environmental category of the part.

Multiple part markings will be inside parentheses. Only one part marking contained in parentheses and separated by a "~" will appear on a part. If a line is indented then it is a continuation of the previous line and the two combined represent the entire part marking for that device.

Important Information and Disclaimer:The information provided on this page represents TI's knowledge and belief as of the date that it is provided. TI bases its knowledge and belief on information provided by third parties, and makes no representation or warranty as to the accuracy of such information. Efforts are underway to better integrate information from third parties. TI has taken and continues to take reasonable steps to provide representative and accurate information but may not have conducted destructive testing or chemical analysis on incoming materials and chemicals. TI and TI suppliers consider certain information to be proprietary, and thus CAS numbers and other limited information may not be available for release.

In no event shall TI's liability arising out of such information exceed the total purchase price of the TI part(s) at issue in this document sold by TI to Customer on an annual basis.

OTHER QUALIFIED VERSIONS OF TLV9001, TLV9002, TLV9004 :

- Automotive : [TLV9001-Q1](#), [TLV9002-Q1](#), [TLV9004-Q1](#)

NOTE: Qualified Version Definitions:

- Automotive - Q100 devices qualified for high-reliability automotive applications targeting zero defects

TAPE AND REEL INFORMATION



QUADRANT ASSIGNMENTS FOR PIN 1 ORIENTATION IN TAPE

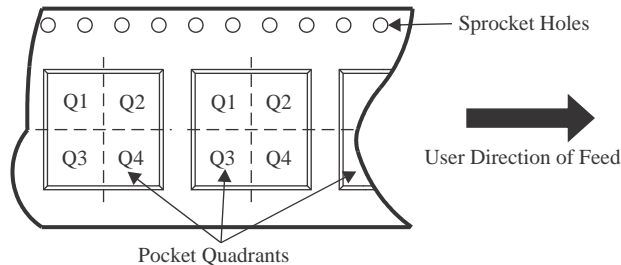

*All dimensions are nominal

Device	Package Type	Package Drawing	Pins	SPQ	Reel Diameter (mm)	Reel Width W1 (mm)	A0 (mm)	B0 (mm)	K0 (mm)	P1 (mm)	W (mm)	Pin1 Quadrant
TLV9001IDBVR	SOT-23	DBV	5	3000	178.0	8.4	3.2	3.2	1.4	4.0	8.0	Q3
TLV9001IDCKR	SC70	DCK	5	3000	178.0	8.4	2.25	2.45	1.2	4.0	8.0	Q3
TLV9001IDPWR	X2SON	DPW	5	3000	178.0	8.4	0.91	0.91	0.5	2.0	8.0	Q2
TLV9001SIDBVR	SOT-23	DBV	6	3000	180.0	8.4	3.2	3.2	1.4	4.0	8.0	Q3
TLV9001SIDBVRG4	SOT-23	DBV	6	3000	180.0	8.4	3.2	3.2	1.4	4.0	8.0	Q3
TLV9001SIDCKR	SC70	DCK	6	3000	178.0	8.4	2.25	2.45	1.2	4.0	8.0	Q3
TLV9001TIDCKR	SC70	DCK	5	3000	180.0	8.4	2.3	2.5	1.2	4.0	8.0	Q3
TLV9001UIDBVR	SOT-23	DBV	5	3000	178.0	8.4	3.2	3.2	1.4	4.0	8.0	Q3
TLV9001ZIDPWR	X2SON	DPW	5	3000	178.0	8.4	0.91	0.91	0.5	2.0	8.0	Q2
TLV9001ZIDPWR	X2SON	DPW	5	3000	180.0	8.4	0.91	0.91	0.5	2.0	8.0	Q2
TLV9002IDDFR	SOT-23-THIN	DDF	8	3000	180.0	8.4	3.2	3.2	1.4	4.0	8.0	Q3
TLV9002IDDFRG4	SOT-23-THIN	DDF	8	3000	180.0	8.4	3.2	3.2	1.4	4.0	8.0	Q3
TLV9002IDGKR	VSSOP	DGK	8	2500	330.0	12.4	5.3	3.4	1.4	8.0	12.0	Q1
TLV9002IDGKR	VSSOP	DGK	8	2500	330.0	12.4	5.25	3.35	1.25	8.0	12.0	Q1
TLV9002IDGKRG4	VSSOP	DGK	8	2500	330.0	12.4	5.3	3.4	1.4	8.0	12.0	Q1

Device	Package Type	Package Drawing	Pins	SPQ	Reel Diameter (mm)	Reel Width W1 (mm)	A0 (mm)	B0 (mm)	K0 (mm)	P1 (mm)	W (mm)	Pin1 Quadrant
TLV9002IDGKT	VSSOP	DGK	8	250	330.0	12.4	5.3	3.4	1.4	8.0	12.0	Q1
TLV9002IDR	SOIC	D	8	2500	330.0	12.4	6.4	5.2	2.1	8.0	12.0	Q1
TLV9002IDRG4	SOIC	D	8	2500	330.0	12.4	6.4	5.2	2.1	8.0	12.0	Q1
TLV9002IDSGR	WSO	DSG	8	3000	180.0	8.4	2.3	2.3	1.15	4.0	8.0	Q2
TLV9002IDSGRG4	WSO	DSG	8	3000	180.0	8.4	2.3	2.3	1.15	4.0	8.0	Q2
TLV9002IDSGT	WSO	DSG	8	250	180.0	8.4	2.3	2.3	1.15	4.0	8.0	Q2
TLV9002IPWR	TSSOP	PW	8	2000	330.0	12.4	7.0	3.6	1.6	8.0	12.0	Q1
TLV9002SIDGSR	VSSOP	DGS	10	2500	330.0	12.4	5.3	3.4	1.4	8.0	12.0	Q1
TLV9002SIRUGR	X2QFN	RUG	10	3000	178.0	8.4	1.75	2.25	0.56	4.0	8.0	Q1
TLV9002SIYCKR	DSBGA	YCK	9	3000	180.0	8.4	1.1	1.1	0.4	2.0	8.0	Q1
TLV9004IDR	SOIC	D	14	2500	330.0	16.4	6.5	9.0	2.1	8.0	16.0	Q1
TLV9004IDR	SOIC	D	14	2500	330.0	16.4	6.5	9.0	2.1	8.0	16.0	Q1
TLV9004IDRG4	SOIC	D	14	2500	330.0	16.4	6.5	9.0	2.1	8.0	16.0	Q1
TLV9004IDYYR	SOT-23-THIN	DYY	14	3000	330.0	12.4	4.8	3.6	1.6	8.0	12.0	Q3
TLV9004IPWR	TSSOP	PW	14	2000	330.0	12.4	6.9	5.6	1.6	8.0	12.0	Q1
TLV9004IPWR	TSSOP	PW	14	2000	330.0	12.4	6.9	5.6	1.6	8.0	12.0	Q1
TLV9004IRTER	WQFN	RTE	16	3000	330.0	12.4	3.3	3.3	1.1	8.0	12.0	Q2
TLV9004IRUCR	QFN	RUC	14	3000	180.0	9.5	2.16	2.16	0.5	4.0	8.0	Q2
TLV9004IRUCRG4	QFN	RUC	14	3000	180.0	9.5	2.16	2.16	0.5	4.0	8.0	Q2
TLV9004SIRTER	WQFN	RTE	16	3000	330.0	12.4	3.3	3.3	1.1	8.0	12.0	Q2

TAPE AND REEL BOX DIMENSIONS

*All dimensions are nominal

Device	Package Type	Package Drawing	Pins	SPQ	Length (mm)	Width (mm)	Height (mm)
TLV9001IDBVR	SOT-23	DBV	5	3000	208.0	191.0	35.0
TLV9001IDCKR	SC70	DCK	5	3000	208.0	191.0	35.0
TLV9001IDPWR	X2SON	DPW	5	3000	205.0	200.0	33.0
TLV9001SIDBVR	SOT-23	DBV	6	3000	210.0	185.0	35.0
TLV9001SIDBVRG4	SOT-23	DBV	6	3000	210.0	185.0	35.0
TLV9001SIDCKR	SC70	DCK	6	3000	208.0	191.0	35.0
TLV9001TIDCKR	SC70	DCK	5	3000	210.0	185.0	35.0
TLV9001UIDBVR	SOT-23	DBV	5	3000	208.0	191.0	35.0
TLV9001ZIDPWR	X2SON	DPW	5	3000	205.0	200.0	33.0
TLV9001ZIDPWR	X2SON	DPW	5	3000	210.0	185.0	35.0
TLV9002IDDFR	SOT-23-THIN	DDF	8	3000	210.0	185.0	35.0
TLV9002IDDFRG4	SOT-23-THIN	DDF	8	3000	210.0	185.0	35.0
TLV9002IDGKR	VSSOP	DGK	8	2500	356.0	356.0	36.0
TLV9002IDGKR	VSSOP	DGK	8	2500	366.0	364.0	50.0
TLV9002IDGKRG4	VSSOP	DGK	8	2500	353.0	353.0	32.0
TLV9002IDGKT	VSSOP	DGK	8	250	353.0	353.0	32.0
TLV9002IDR	SOIC	D	8	2500	353.0	353.0	32.0
TLV9002IDRG4	SOIC	D	8	2500	353.0	353.0	32.0

Device	Package Type	Package Drawing	Pins	SPQ	Length (mm)	Width (mm)	Height (mm)
TLV9002IDSGR	WSON	DSG	8	3000	210.0	185.0	35.0
TLV9002IDSGRG4	WSON	DSG	8	3000	210.0	185.0	35.0
TLV9002IDSGT	WSON	DSG	8	250	210.0	185.0	35.0
TLV9002IPWR	TSSOP	PW	8	2000	353.0	353.0	32.0
TLV9002SIDGSR	VSSOP	DGS	10	2500	366.0	364.0	50.0
TLV9002SIRUGR	X2QFN	RUG	10	3000	205.0	200.0	33.0
TLV9002SIYCKR	DSBGA	YCK	9	3000	182.0	182.0	20.0
TLV9004IDR	SOIC	D	14	2500	353.0	353.0	32.0
TLV9004IDR	SOIC	D	14	2500	353.0	353.0	32.0
TLV9004IDRG4	SOIC	D	14	2500	353.0	353.0	32.0
TLV9004IDYYR	SOT-23-THIN	DYY	14	3000	336.6	336.6	31.8
TLV9004IPWR	TSSOP	PW	14	2000	353.0	353.0	32.0
TLV9004IPWR	TSSOP	PW	14	2000	356.0	356.0	35.0
TLV9004IRTER	WQFN	RTE	16	3000	367.0	367.0	35.0
TLV9004IRUCR	QFN	RUC	14	3000	205.0	200.0	30.0
TLV9004IRUCRG4	QFN	RUC	14	3000	205.0	200.0	30.0
TLV9004SIRTER	WQFN	RTE	16	3000	367.0	367.0	35.0

EXAMPLE BOARD LAYOUT

DBV0005A

SOT-23 - 1.45 mm max height

SMALL OUTLINE TRANSISTOR



LAND PATTERN EXAMPLE
EXPOSED METAL SHOWN
SCALE:15X



SOLDER MASK DETAILS

4214839/K 08/2024

NOTES: (continued)

- 6. Publication IPC-7351 may have alternate designs.
- 7. Solder mask tolerances between and around signal pads can vary based on board fabrication site.

EXAMPLE STENCIL DESIGN

DBV0005A

SOT-23 - 1.45 mm max height

SMALL OUTLINE TRANSISTOR



SOLDER PASTE EXAMPLE
BASED ON 0.125 mm THICK STENCIL
SCALE:15X

4214839/K 08/2024

NOTES: (continued)

8. Laser cutting apertures with trapezoidal walls and rounded corners may offer better paste release. IPC-7525 may have alternate design recommendations.
9. Board assembly site may have different recommendations for stencil design.

DGK0008A



PACKAGE OUTLINE

VSSOP - 1.1 mm max height

SMALL OUTLINE PACKAGE



4214862/A 04/2023

NOTES:

PowerPAD is a trademark of Texas Instruments.

1. All linear dimensions are in millimeters. Any dimensions in parenthesis are for reference only. Dimensioning and tolerancing per ASME Y14.5M.
2. This drawing is subject to change without notice.
3. This dimension does not include mold flash, protrusions, or gate burrs. Mold flash, protrusions, or gate burrs shall not exceed 0.15 mm per side.
4. This dimension does not include interlead flash. Interlead flash shall not exceed 0.25 mm per side.
5. Reference JEDEC registration MO-187.

EXAMPLE BOARD LAYOUT

DGK0008A

TM VSSOP - 1.1 mm max height

SMALL OUTLINE PACKAGE



LAND PATTERN EXAMPLE
EXPOSED METAL SHOWN
SCALE: 15X

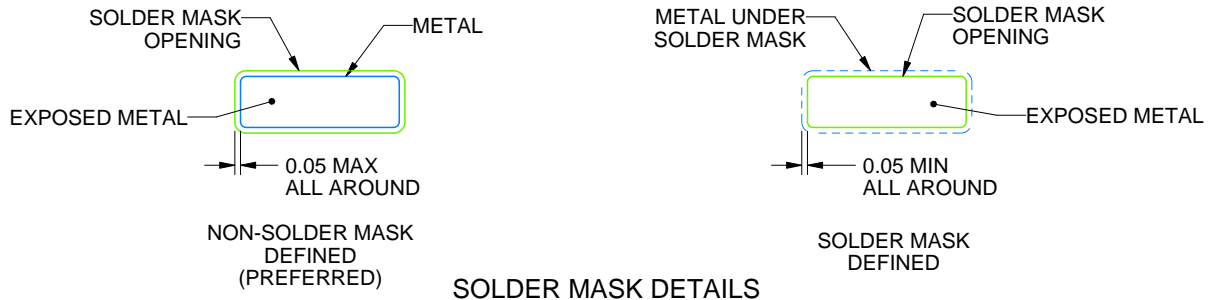

SOLDER MASK DETAILS

4214862/A 04/2023

NOTES: (continued)

6. Publication IPC-7351 may have alternate designs.
7. Solder mask tolerances between and around signal pads can vary based on board fabrication site.
8. Vias are optional depending on application, refer to device data sheet. If any vias are implemented, refer to their locations shown on this view. It is recommended that vias under paste be filled, plugged or tented.
9. Size of metal pad may vary due to creepage requirement.

EXAMPLE STENCIL DESIGN

DGK0008A

™ VSSOP - 1.1 mm max height

SMALL OUTLINE PACKAGE



SOLDER PASTE EXAMPLE
SCALE: 15X

4214862/A 04/2023

NOTES: (continued)

11. Laser cutting apertures with trapezoidal walls and rounded corners may offer better paste release. IPC-7525 may have alternate design recommendations.
12. Board assembly site may have different recommendations for stencil design.

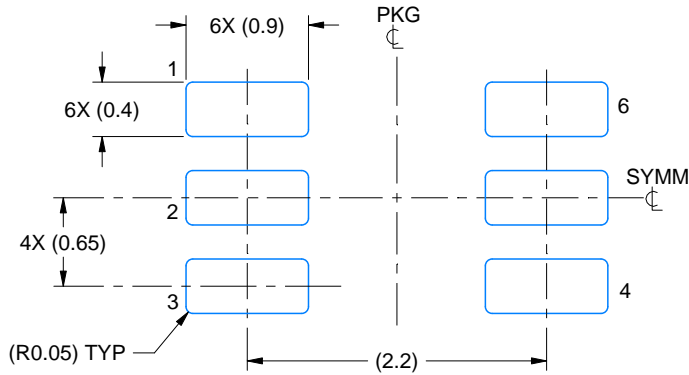

LAND PATTERN EXAMPLE
EXPOSED METAL SHOWN
SCALE:18X

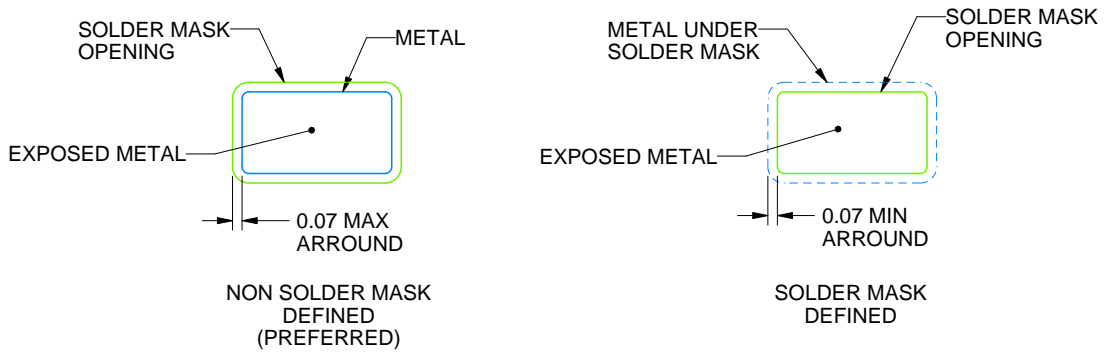

SOLDER MASK DETAILS

4214835/D 11/2024

NOTES: (continued)

- 5. Publication IPC-7351 may have alternate designs.
- 6. Solder mask tolerances between and around signal pads can vary based on board fabrication site.

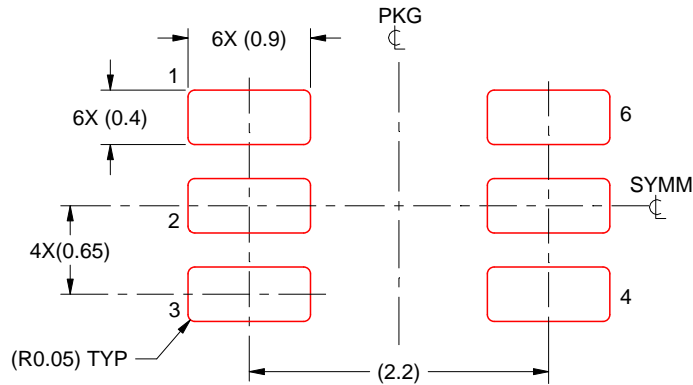

SOLDER PASTE EXAMPLE
BASED ON 0.125 THICK STENCIL
SCALE:18X

4214835/D 11/2024

NOTES: (continued)

7. Laser cutting apertures with trapezoidal walls and rounded corners may offer better paste release. IPC-7525 may have alternate design recommendations.
8. Board assembly site may have different recommendations for stencil design.

GENERIC PACKAGE VIEW

RTE 16

WQFN - 0.8 mm max height

3 x 3, 0.5 mm pitch

PLASTIC QUAD FLATPACK - NO LEAD

This image is a representation of the package family, actual package may vary.
Refer to the product data sheet for package details.

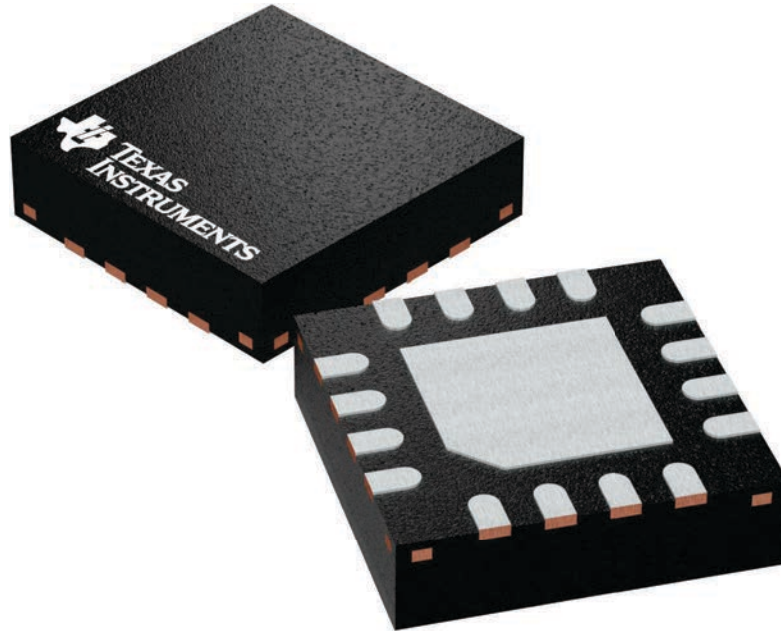

4225944/A

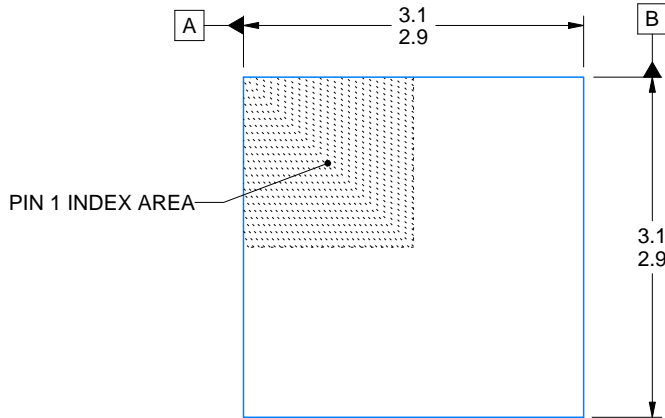

SIDE WALL METAL THICKNESS DIM A	
OPTION 1	OPTION 2
0.1	0.2

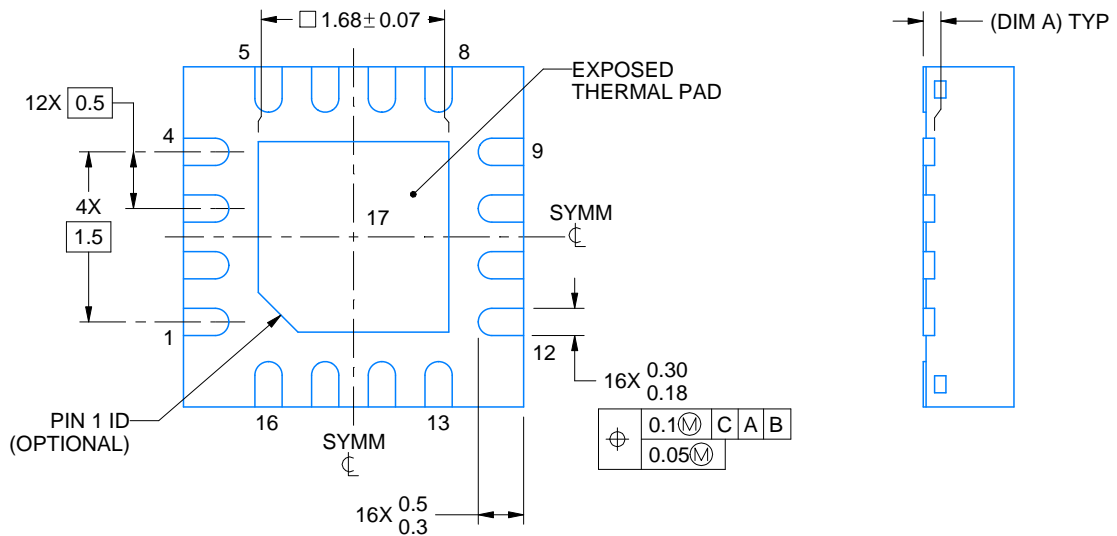
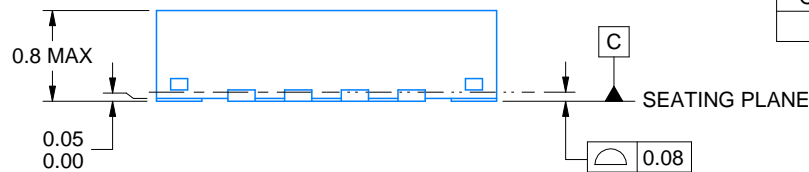

4219117/B 04/2022

NOTES:

1. All linear dimensions are in millimeters. Any dimensions in parenthesis are for reference only. Dimensioning and tolerancing per ASME Y14.5M.
2. This drawing is subject to change without notice.
3. The package thermal pad must be soldered to the printed circuit board for thermal and mechanical performance.

EXAMPLE BOARD LAYOUT

RTE0016C

WQFN - 0.8 mm max height

PLASTIC QUAD FLATPACK - NO LEAD

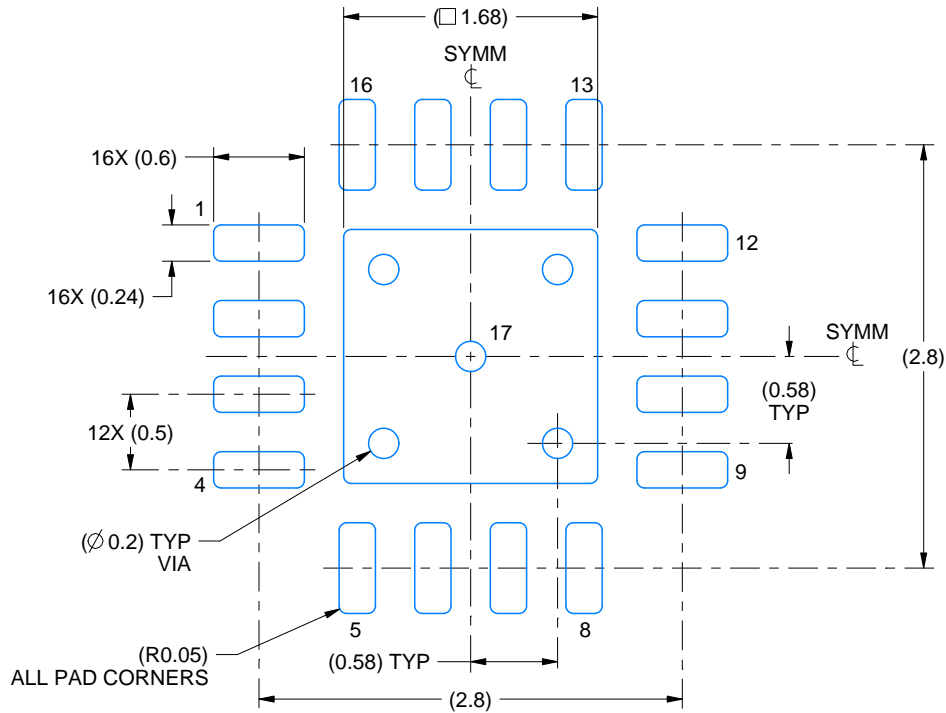

LAND PATTERN EXAMPLE
EXPOSED METAL SHOWN
SCALE:20X

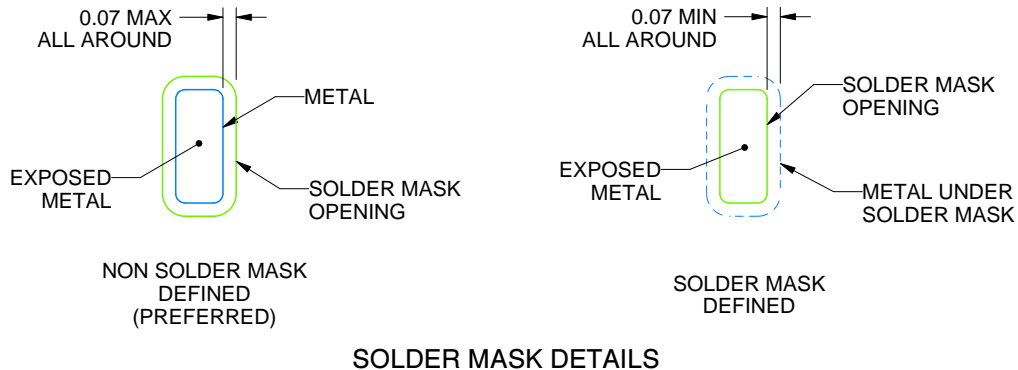

4219117/B 04/2022

NOTES: (continued)

- This package is designed to be soldered to a thermal pad on the board. For more information, see Texas Instruments literature number SLUA271 (www.ti.com/lit/slua271).
- Vias are optional depending on application, refer to device data sheet. If any vias are implemented, refer to their locations shown on this view. It is recommended that vias under paste be filled, plugged or tented.

EXAMPLE STENCIL DESIGN

RTE0016C

WQFN - 0.8 mm max height

PLASTIC QUAD FLATPACK - NO LEAD

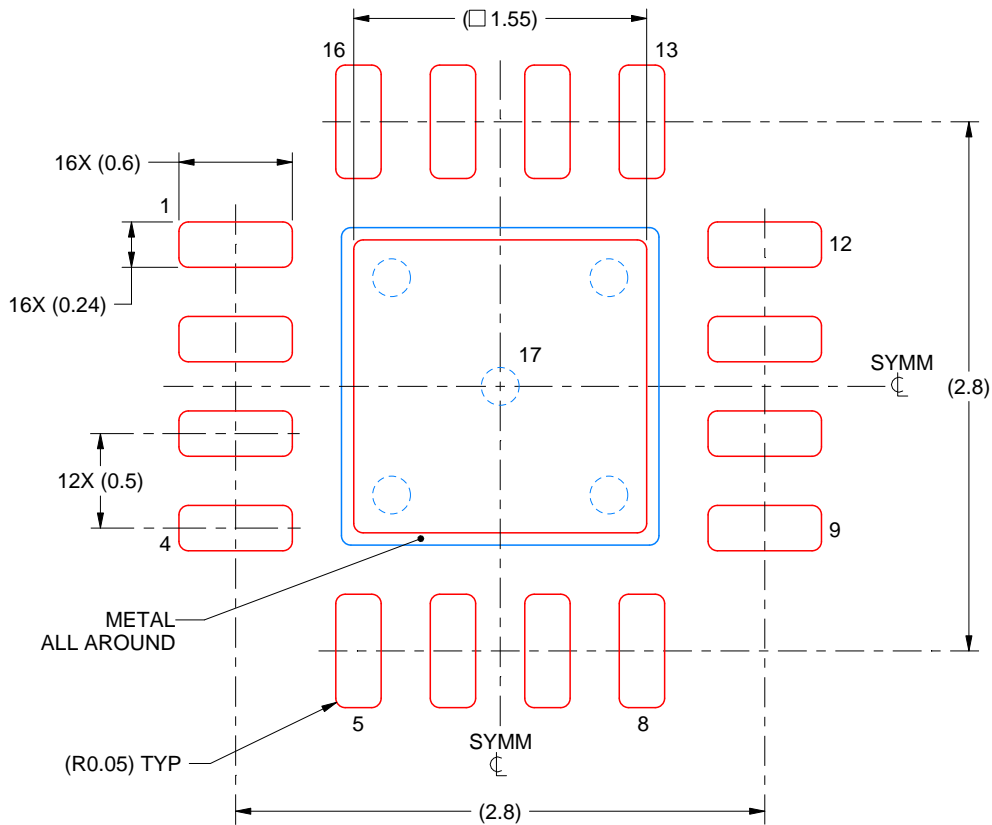

SOLDER PASTE EXAMPLE
BASED ON 0.125 mm THICK STENCIL

EXPOSED PAD 17:
85% PRINTED SOLDER COVERAGE BY AREA UNDER PACKAGE
SCALE:25X

4219117/B 04/2022

NOTES: (continued)

6. Laser cutting apertures with trapezoidal walls and rounded corners may offer better paste release. IPC-7525 may have alternate design recommendations.

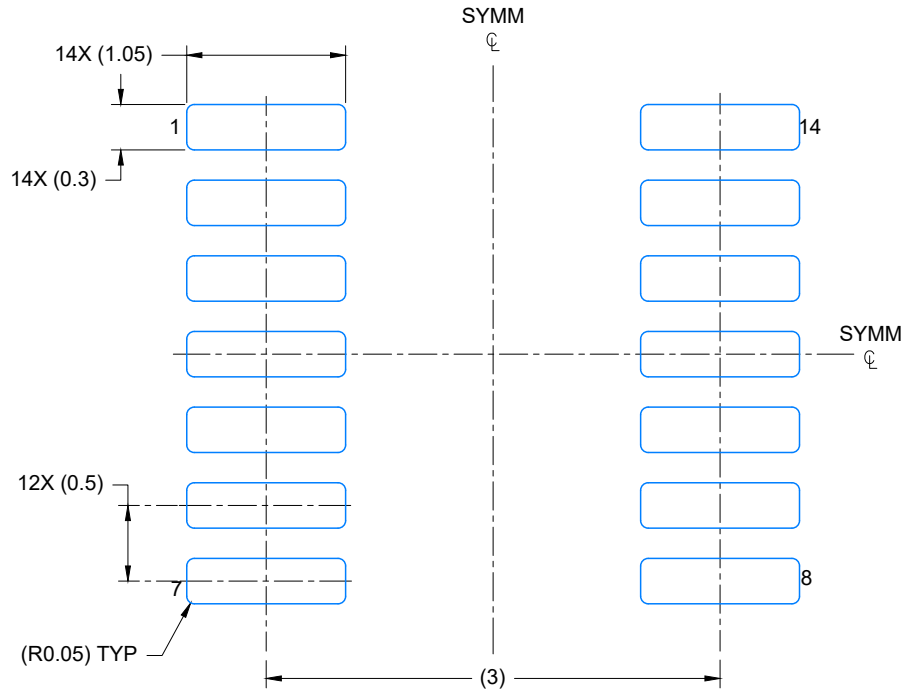

LAND PATTERN EXAMPLE
EXPOSED METAL SHOWN
SCALE: 20X

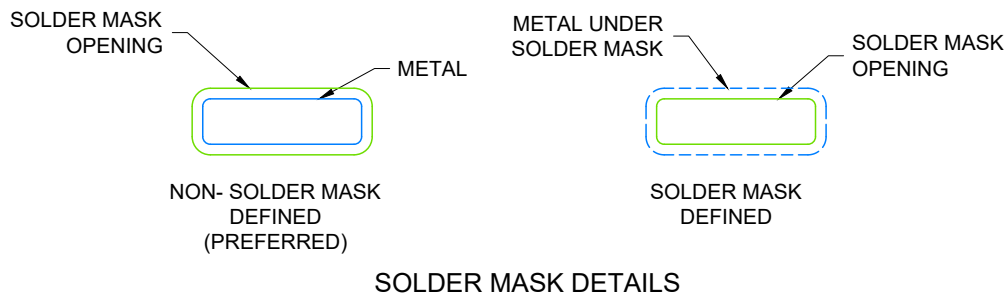

4224643/D 07/2024

NOTES: (continued)

- 6. Publication IPC-7351 may have alternate designs.
- 7. Solder mask tolerances between and around signal pads can vary based on board fabrication site.

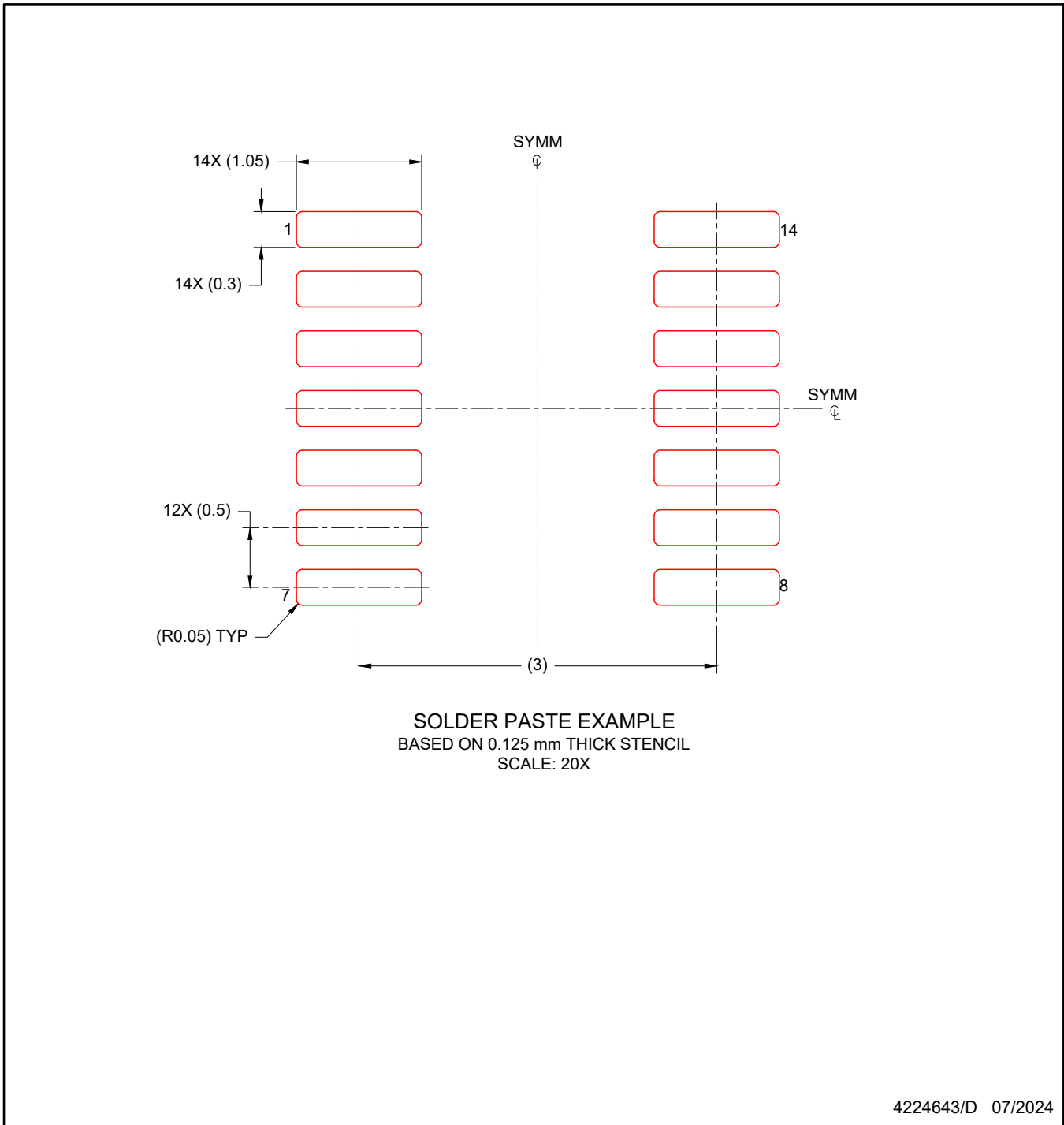

NOTES: (continued)

8. Laser cutting apertures with trapezoidal walls and rounded corners may offer better paste release. IPC-7525 may have alternate design recommendations.
9. Board assembly site may have different recommendations for stencil design.

DGS0010A

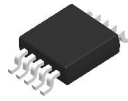

PACKAGE OUTLINE

VSSOP - 1.1 mm max height

SMALL OUTLINE PACKAGE

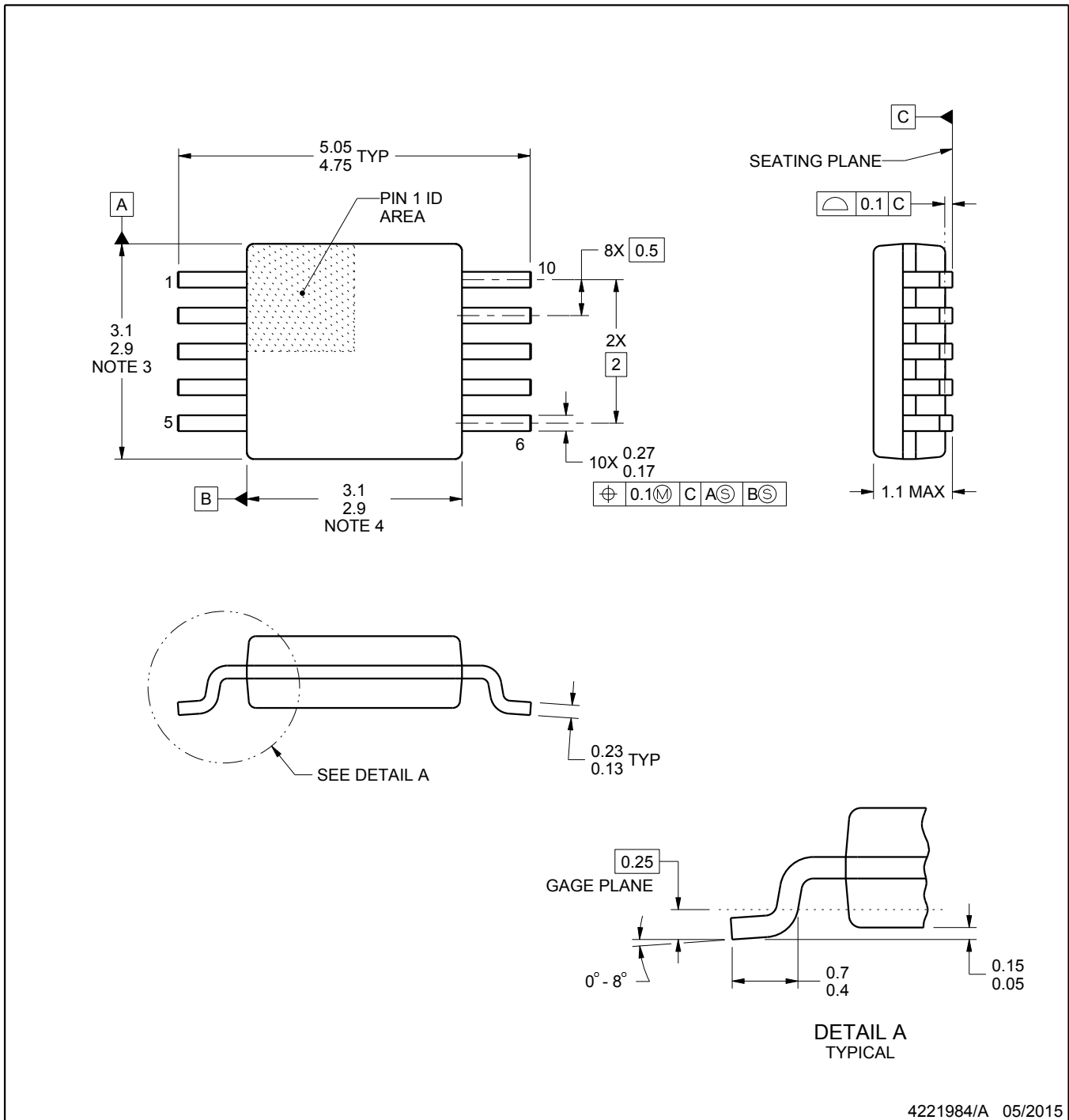

4221984/A 05/2015

NOTES:

1. All linear dimensions are in millimeters. Any dimensions in parenthesis are for reference only. Dimensioning and tolerancing per ASME Y14.5M.
2. This drawing is subject to change without notice.
3. This dimension does not include mold flash, protrusions, or gate burrs. Mold flash, protrusions, or gate burrs shall not exceed 0.15 mm per side.
4. This dimension does not include interlead flash. Interlead flash shall not exceed 0.25 mm per side.
5. Reference JEDEC registration MO-187, variation BA.

EXAMPLE BOARD LAYOUT

DGS0010A

VSSOP - 1.1 mm max height

SMALL OUTLINE PACKAGE

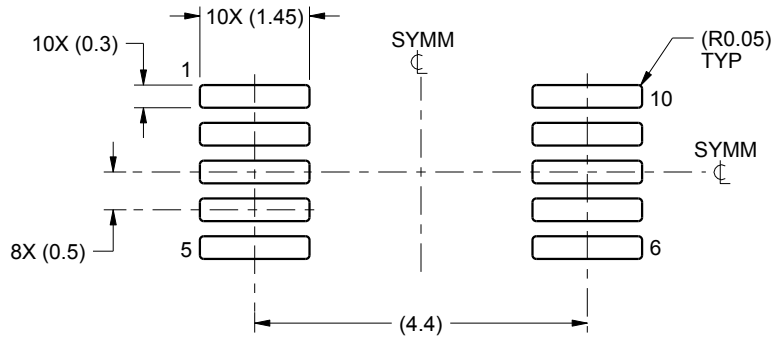

LAND PATTERN EXAMPLE
SCALE:10X

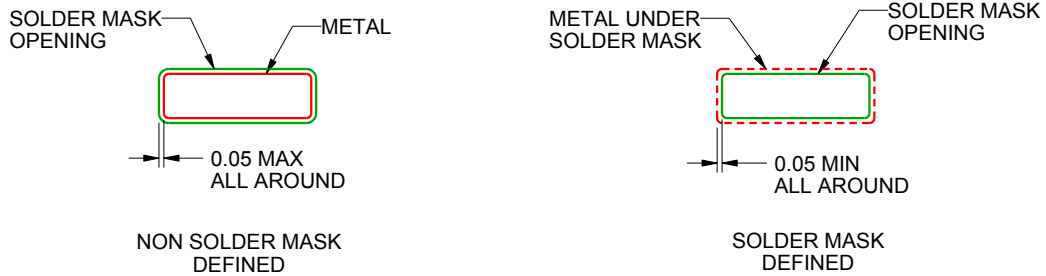

SOLDER MASK DETAILS
NOT TO SCALE

4221984/A 05/2015

NOTES: (continued)

- 6. Publication IPC-7351 may have alternate designs.
- 7. Solder mask tolerances between and around signal pads can vary based on board fabrication site.

EXAMPLE STENCIL DESIGN

DGS0010A

VSSOP - 1.1 mm max height

SMALL OUTLINE PACKAGE

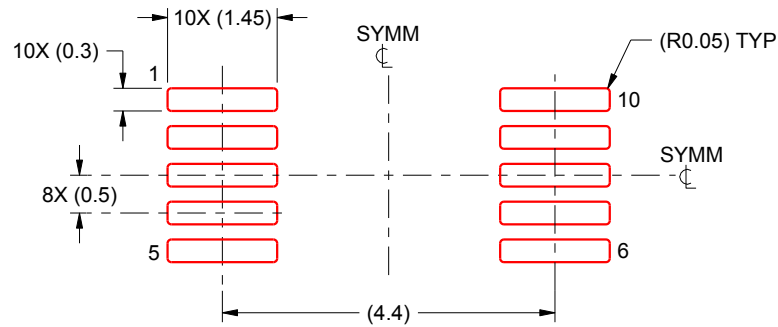

SOLDER PASTE EXAMPLE
BASED ON 0.125 mm THICK STENCIL
SCALE:10X

4221984/A 05/2015

NOTES: (continued)

8. Laser cutting apertures with trapezoidal walls and rounded corners may offer better paste release. IPC-7525 may have alternate design recommendations.
9. Board assembly site may have different recommendations for stencil design.

GENERIC PACKAGE VIEW

DPW 5

X2SON - 0.4 mm max height

PLASTIC SMALL OUTLINE - NO LEAD



Images above are just a representation of the package family, actual package may vary.
Refer to the product data sheet for package details.

4211218-3/D

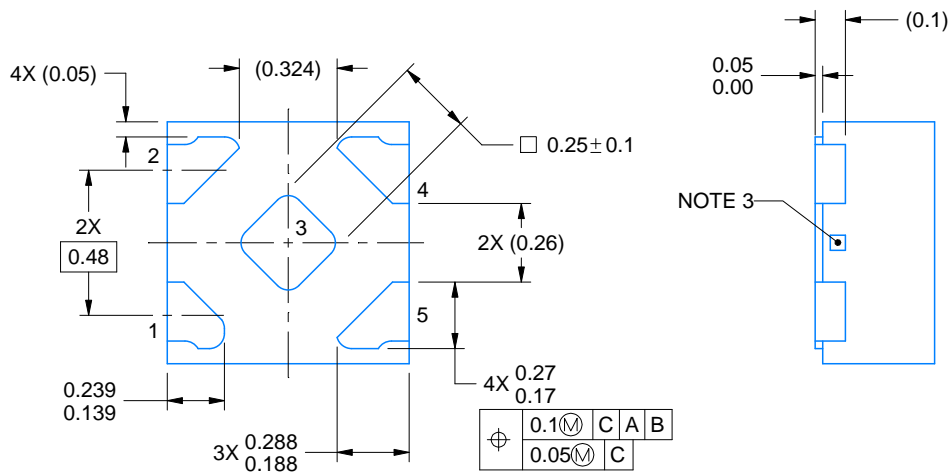
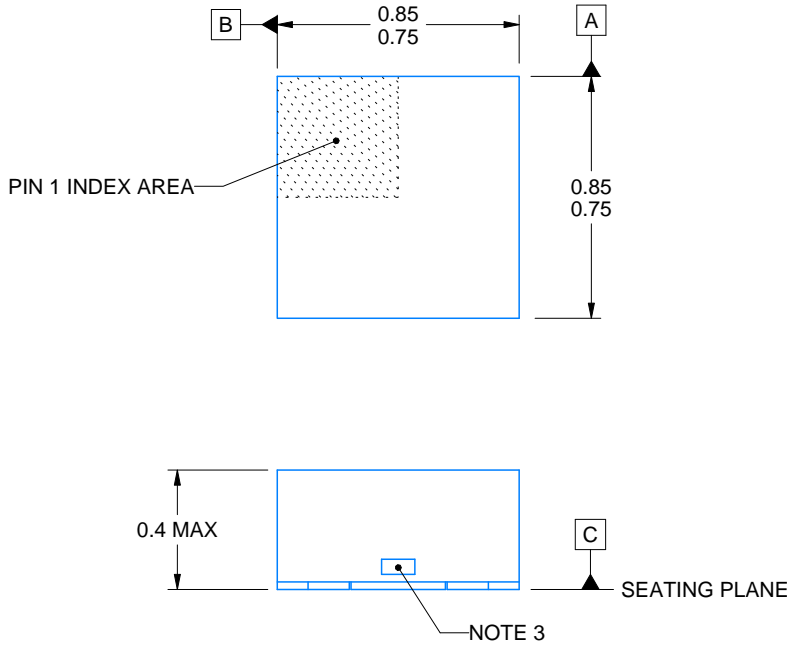
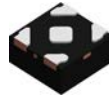

4223102/D 03/2022

NOTES:

1. All linear dimensions are in millimeters. Any dimensions in parenthesis are for reference only. Dimensioning and tolerancing per ASME Y14.5M.
2. This drawing is subject to change without notice.
3. The size and shape of this feature may vary.

EXAMPLE BOARD LAYOUT

DPW0005A

X2SON - 0.4 mm max height

PLASTIC SMALL OUTLINE - NO LEAD

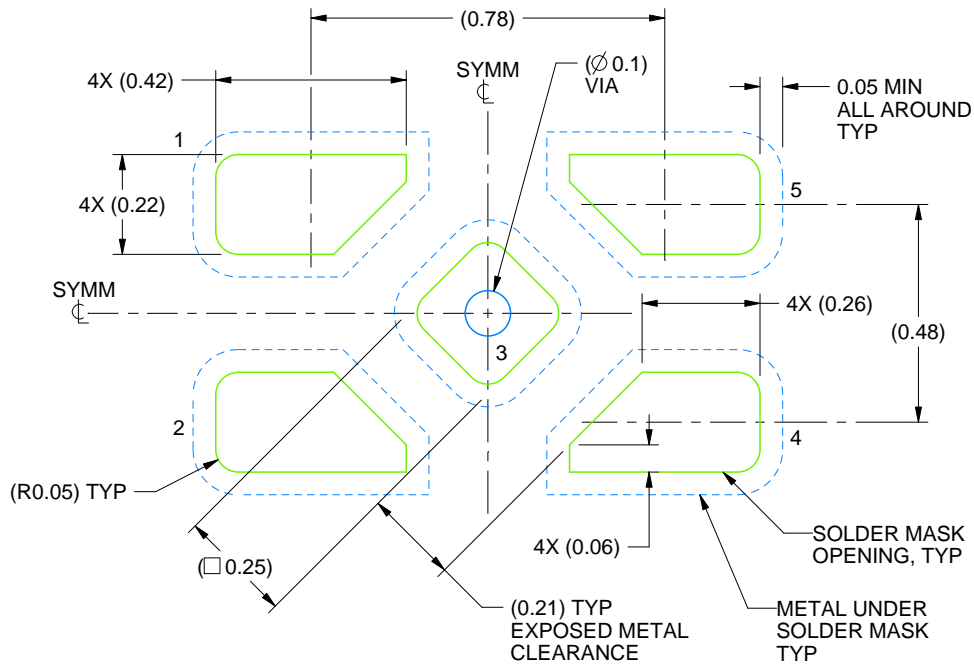

LAND PATTERN EXAMPLE
SOLDER MASK DEFINED
SCALE:60X

4223102/D 03/2022

NOTES: (continued)

4. This package is designed to be soldered to a thermal pad on the board. For more information, refer to QFN/SON PCB application note in literature No. SLUA271 (www.ti.com/lit/slua271).

EXAMPLE STENCIL DESIGN

DPW0005A

X2SON - 0.4 mm max height

PLASTIC SMALL OUTLINE - NO LEAD

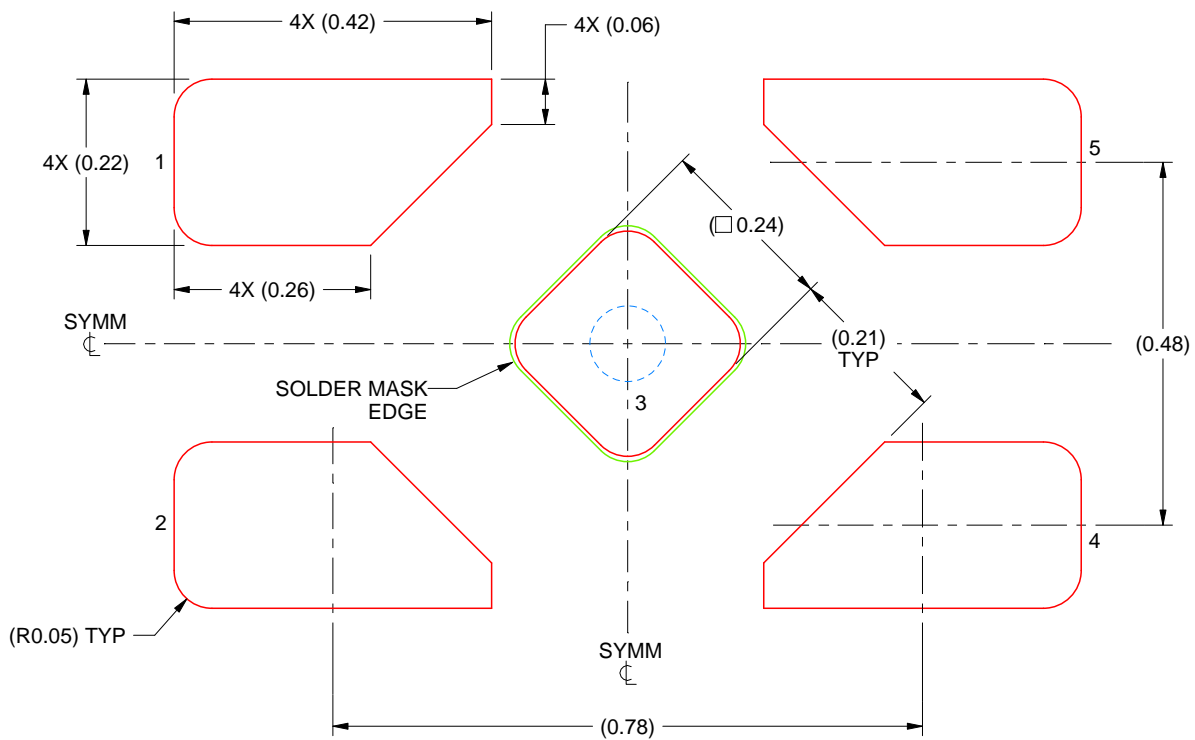

SOLDER PASTE EXAMPLE
BASED ON 0.1 mm THICK STENCIL

EXPOSED PAD 3
92% PRINTED SOLDER COVERAGE BY AREA UNDER PACKAGE
SCALE:100X

4223102/D 03/2022

NOTES: (continued)

5. Laser cutting apertures with trapezoidal walls and rounded corners may offer better paste release. IPC-7525 may have alternate design recommendations.

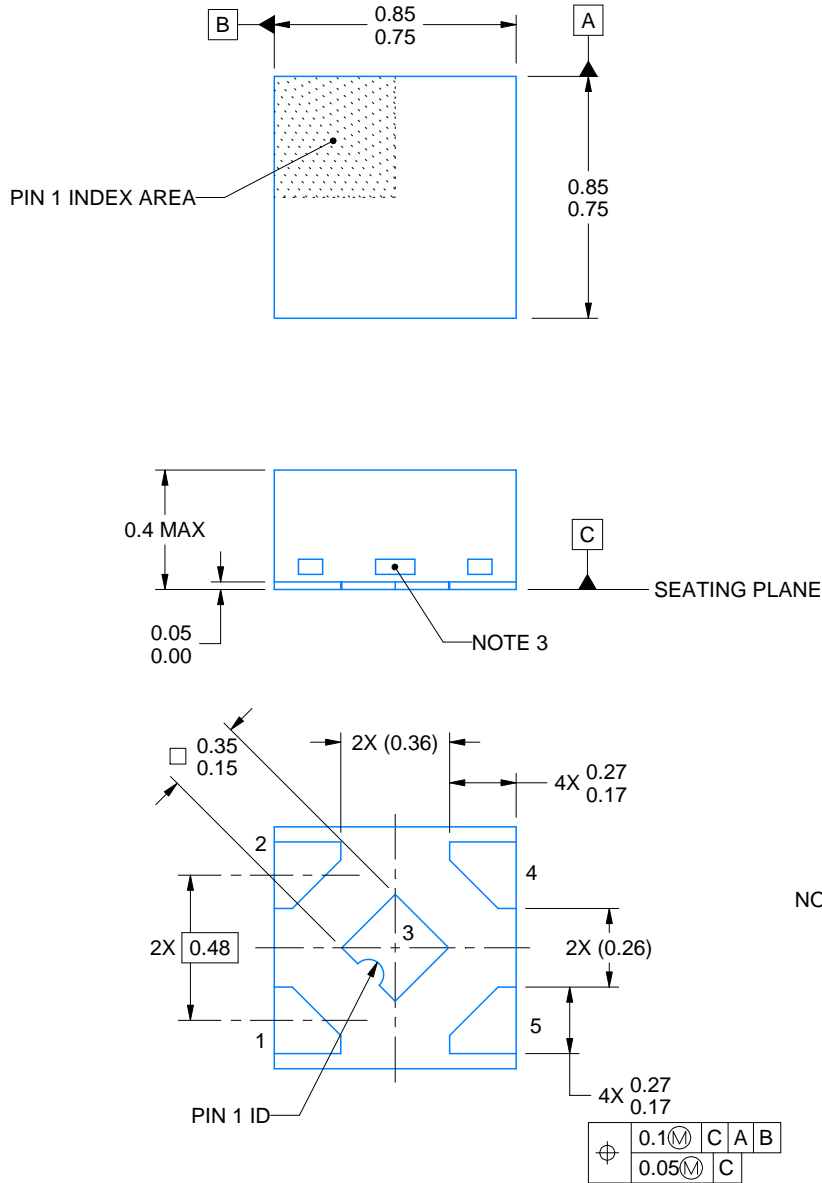
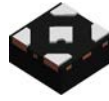

4228233/D 09/2023

NOTES:

1. All linear dimensions are in millimeters. Any dimensions in parenthesis are for reference only. Dimensioning and tolerancing per ASME Y14.5M.
2. This drawing is subject to change without notice.
3. The size and shape of this feature may vary.

EXAMPLE BOARD LAYOUT

DPW0005B

X2SON - 0.4 mm max height

PLASTIC SMALL OUTLINE - NO LEAD

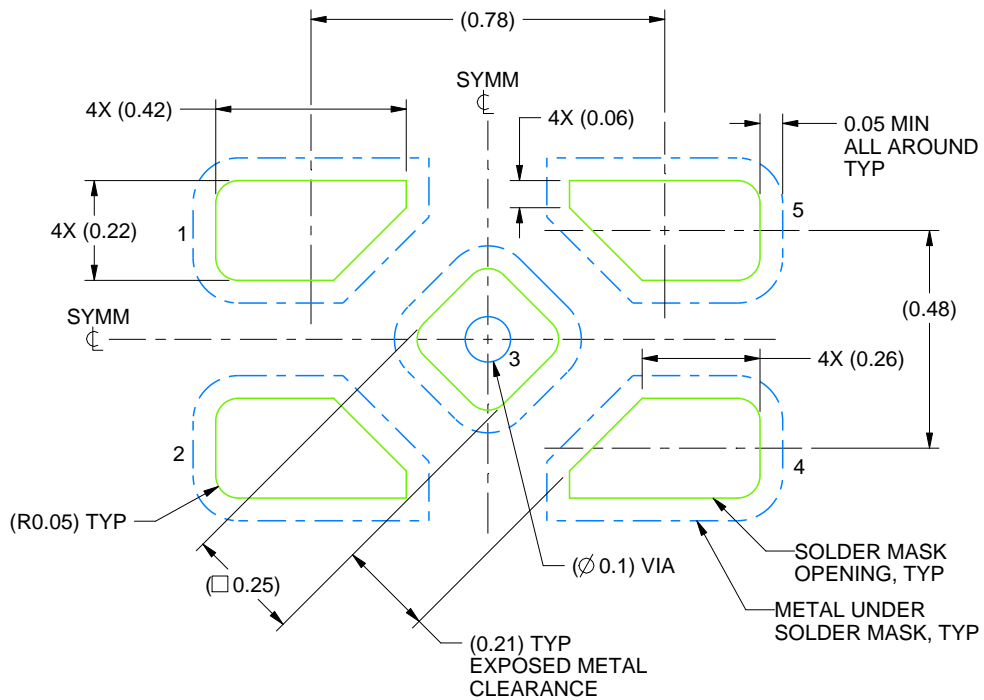

LAND PATTERN EXAMPLE
SOLDER MASK DEFINED
SCALE:60X

4228233/D 09/2023

NOTES: (continued)

4. This package is designed to be soldered to a thermal pad on the board. For more information, refer to QFN/SON PCB application note in literature No. SLUA271 (www.ti.com/lit/slua271).

EXAMPLE STENCIL DESIGN

DPW0005B

X2SON - 0.4 mm max height

PLASTIC SMALL OUTLINE - NO LEAD

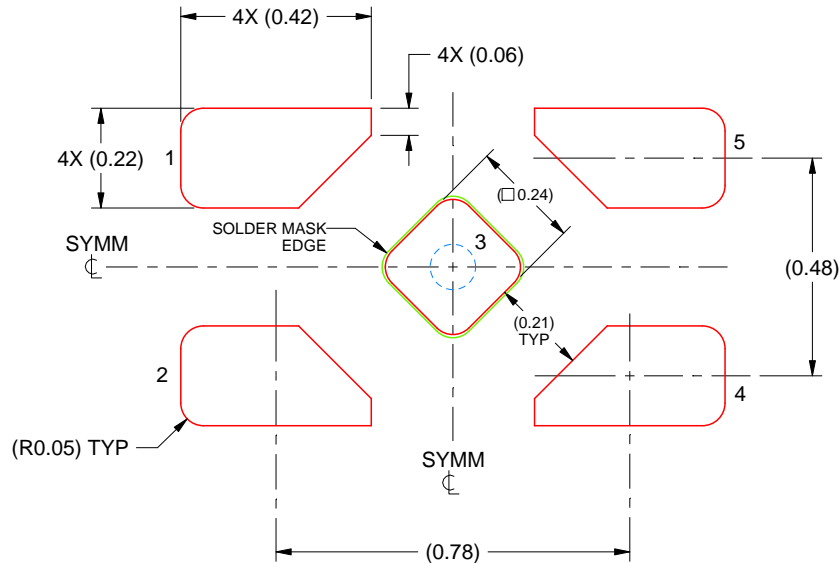

SOLDER PASTE EXAMPLE
BASED ON 0.1 mm THICK STENCIL

EXPOSED PAD 5
92% PRINTED SOLDER COVERAGE BY AREA UNDER PACKAGE
SCALE:60X

4228233/D 09/2023

NOTES: (continued)

5. Laser cutting apertures with trapezoidal walls and rounded corners may offer better paste release. IPC-7525 may have alternate design recommendations.

DCK0005A



PACKAGE OUTLINE

SOT - 1.1 max height

SMALL OUTLINE TRANSISTOR

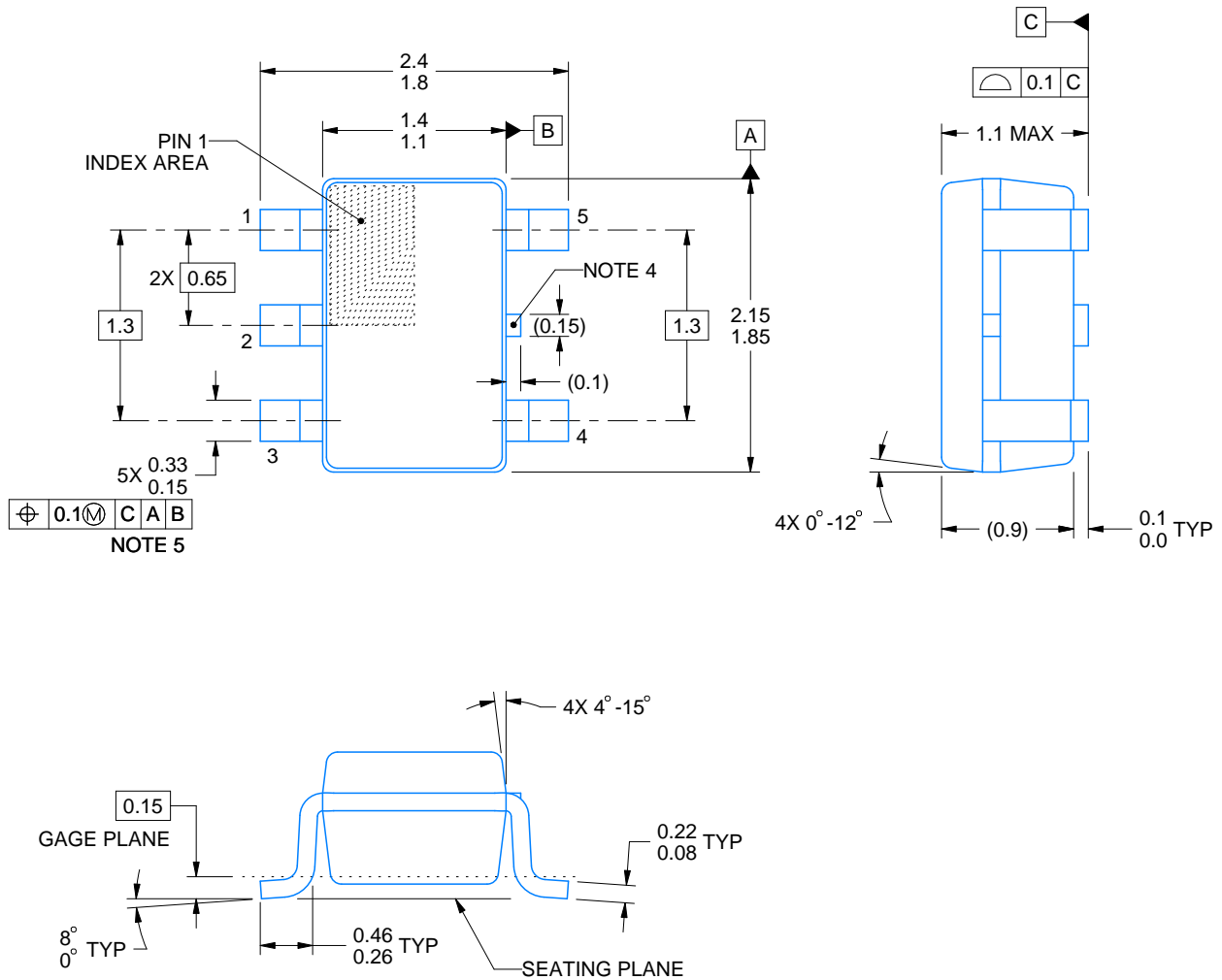

4214834/G 11/2024

NOTES:

1. All linear dimensions are in millimeters. Any dimensions in parenthesis are for reference only. Dimensioning and tolerancing per ASME Y14.5M.
2. This drawing is subject to change without notice.
3. Reference JEDEC MO-203.
4. Support pin may differ or may not be present.
5. Lead width does not comply with JEDEC.
6. Body dimensions do not include mold flash, protrusions, or gate burrs. Mold flash, protrusions, or gate burrs shall not exceed 0.25mm per side

EXAMPLE BOARD LAYOUT

DCK0005A

SOT - 1.1 max height

SMALL OUTLINE TRANSISTOR

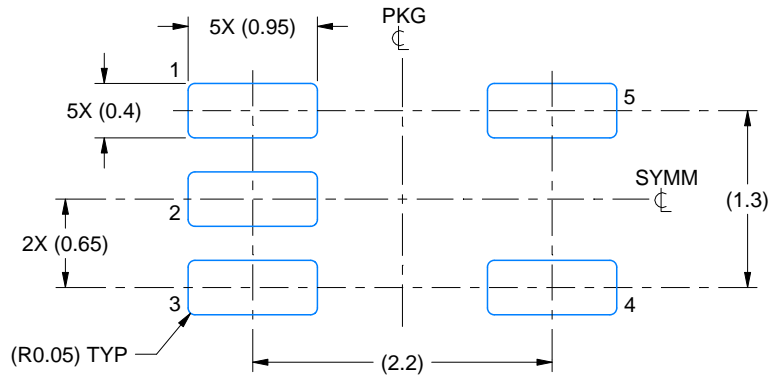

LAND PATTERN EXAMPLE
EXPOSED METAL SHOWN
SCALE:18X

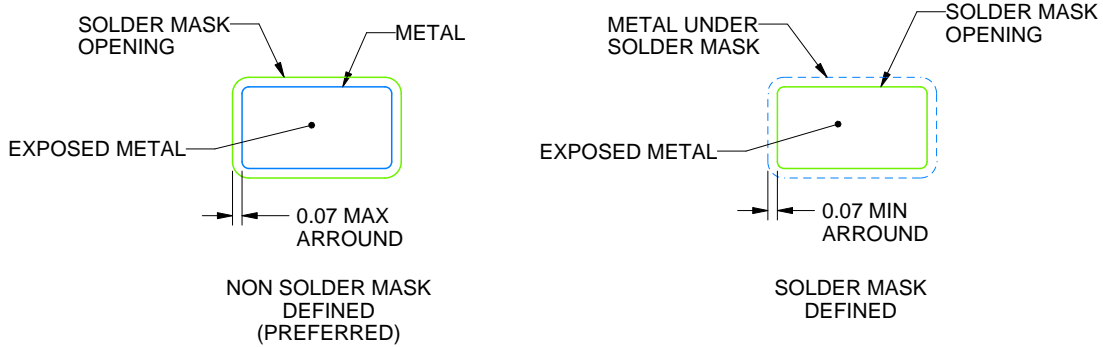

SOLDER MASK DETAILS

4214834/G 11/2024

NOTES: (continued)

- 7. Publication IPC-7351 may have alternate designs.
- 8. Solder mask tolerances between and around signal pads can vary based on board fabrication site.

EXAMPLE STENCIL DESIGN

DCK0005A

SOT - 1.1 max height

SMALL OUTLINE TRANSISTOR

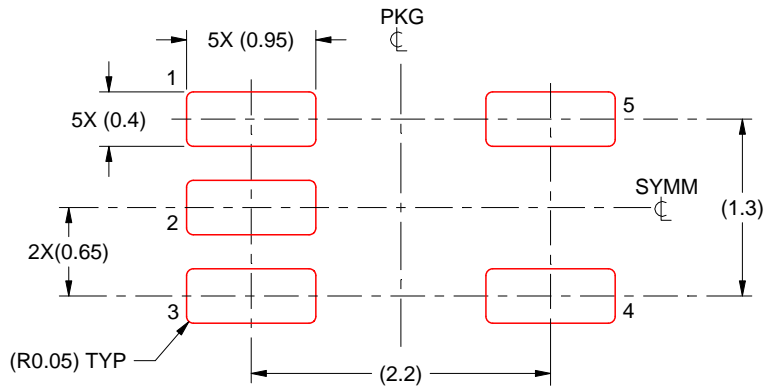

SOLDER PASTE EXAMPLE
BASED ON 0.125 THICK STENCIL
SCALE: 18X

4214834/G 11/2024

NOTES: (continued)

9. Laser cutting apertures with trapezoidal walls and rounded corners may offer better paste release. IPC-7525 may have alternate design recommendations.
10. Board assembly site may have different recommendations for stencil design.

DDF0008A



PACKAGE OUTLINE

SOT-23-THIN - 1.1 mm max height

PLASTIC SMALL OUTLINE

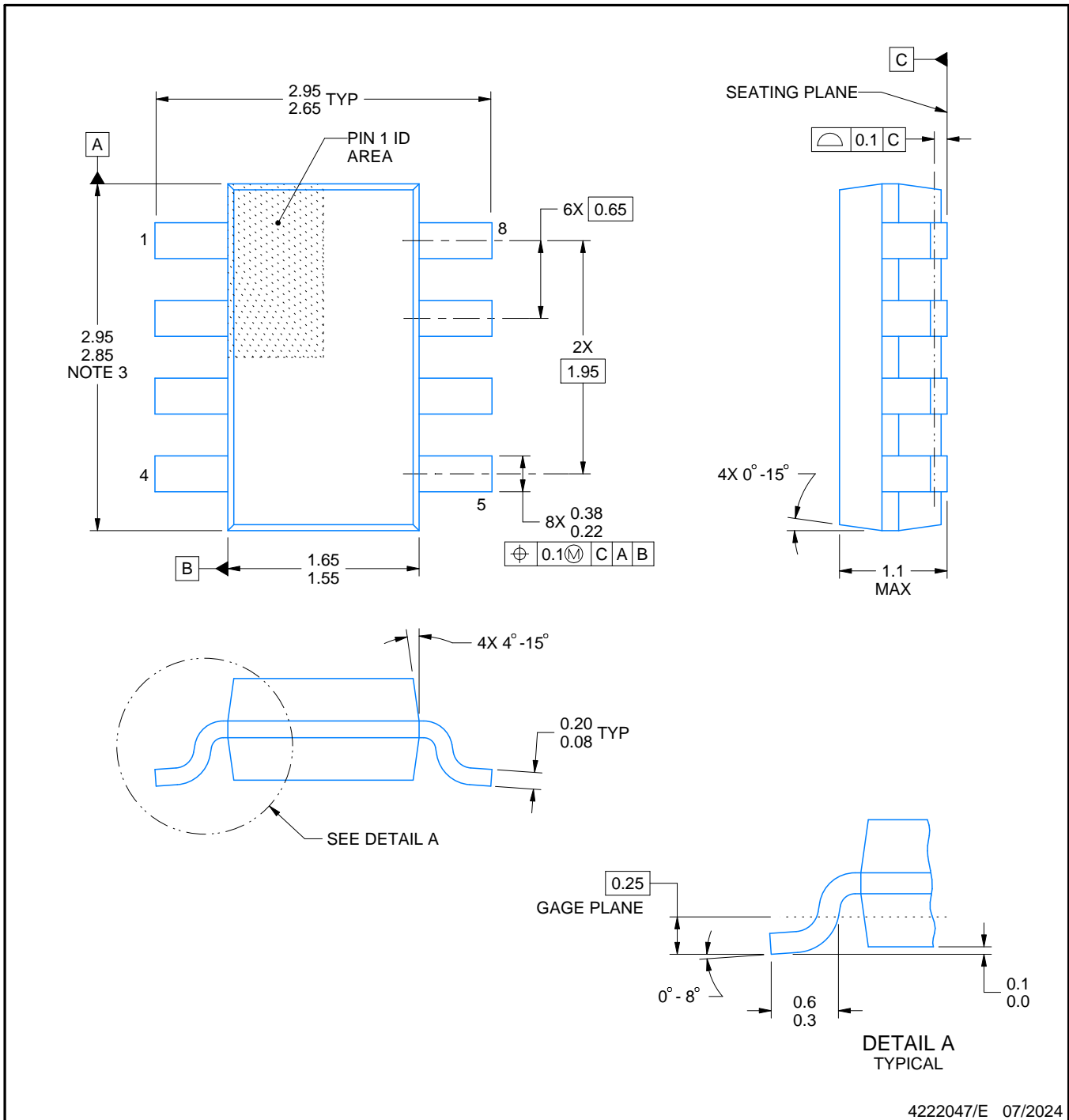

4222047/E 07/2024

NOTES:

1. All linear dimensions are in millimeters. Any dimensions in parenthesis are for reference only. Dimensioning and tolerancing per ASME Y14.5M.
2. This drawing is subject to change without notice.
3. This dimension does not include mold flash, protrusions, or gate burrs. Mold flash, protrusions, or gate burrs shall not exceed 0.15 mm per side.

EXAMPLE BOARD LAYOUT

DDF0008A

SOT-23-THIN - 1.1 mm max height

PLASTIC SMALL OUTLINE

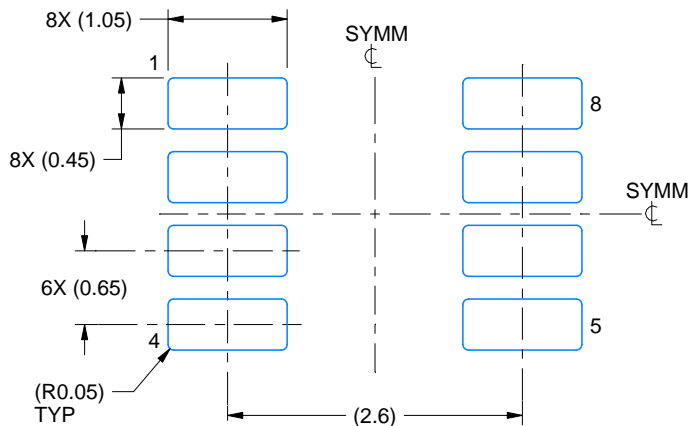

LAND PATTERN EXAMPLE
EXPOSED METAL SHOWN
SCALE:15X

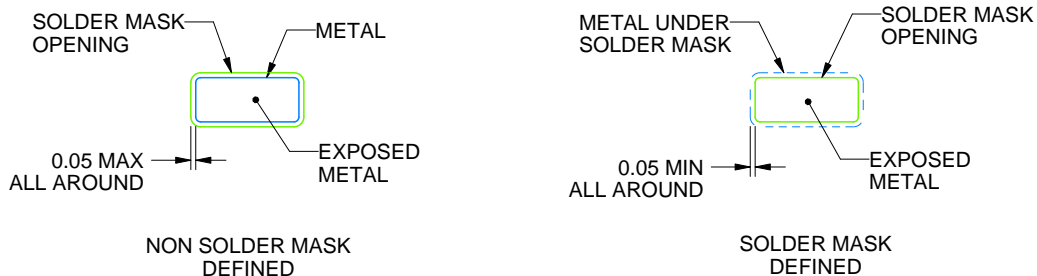

SOLDER MASK DETAILS

4222047/E 07/2024

NOTES: (continued)

- 4. Publication IPC-7351 may have alternate designs.
- 5. Solder mask tolerances between and around signal pads can vary based on board fabrication site.

EXAMPLE STENCIL DESIGN

DDF0008A

SOT-23-THIN - 1.1 mm max height

PLASTIC SMALL OUTLINE

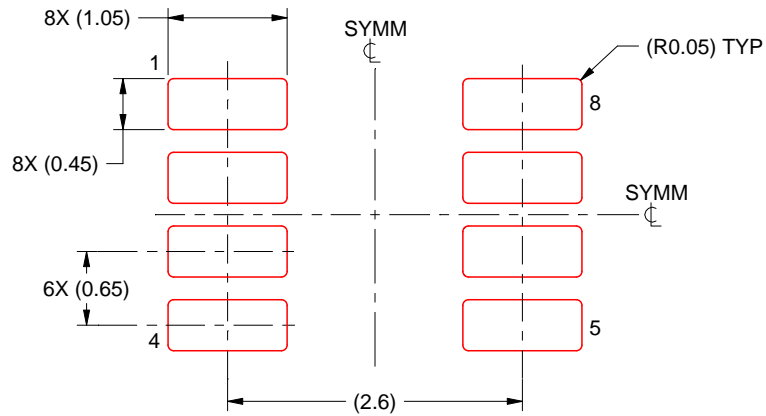

SOLDER PASTE EXAMPLE
BASED ON 0.125 mm THICK STENCIL
SCALE:15X

4222047/E 07/2024

NOTES: (continued)

6. Laser cutting apertures with trapezoidal walls and rounded corners may offer better paste release. IPC-7525 may have alternate design recommendations.
7. Board assembly site may have different recommendations for stencil design.

EXAMPLE BOARD LAYOUT

D0008A

SOIC - 1.75 mm max height

SMALL OUTLINE INTEGRATED CIRCUIT



LAND PATTERN EXAMPLE
 EXPOSED METAL SHOWN
 SCALE:8X



SOLDER MASK DETAILS

4214825/C 02/2019

NOTES: (continued)

- 6. Publication IPC-7351 may have alternate designs.
- 7. Solder mask tolerances between and around signal pads can vary based on board fabrication site.

EXAMPLE STENCIL DESIGN

D0008A

SOIC - 1.75 mm max height

SMALL OUTLINE INTEGRATED CIRCUIT



SOLDER PASTE EXAMPLE
BASED ON .005 INCH [0.125 MM] THICK STENCIL
SCALE:8X

4214825/C 02/2019

NOTES: (continued)

8. Laser cutting apertures with trapezoidal walls and rounded corners may offer better paste release. IPC-7525 may have alternate design recommendations.
9. Board assembly site may have different recommendations for stencil design.

YCK0009

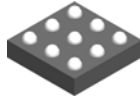

PACKAGE OUTLINE

DSBGA - 0.33 mm max height

DIE SIZE BALL GRID ARRAY

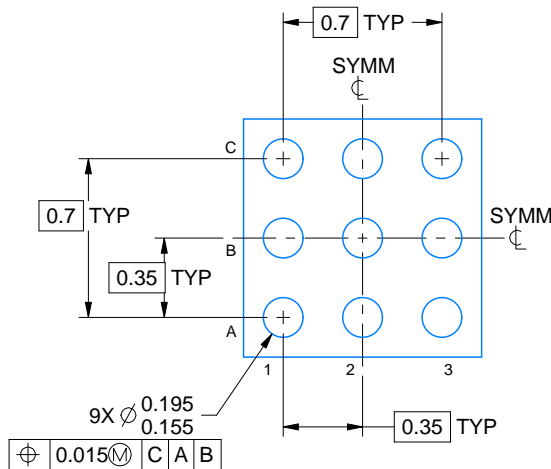
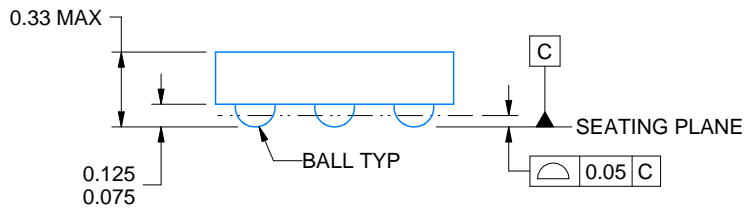
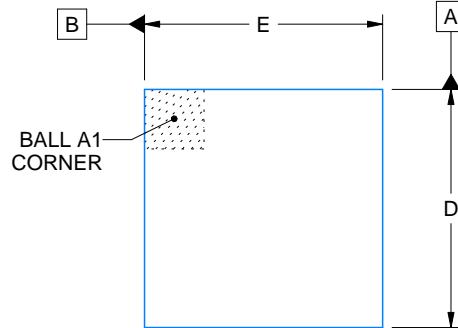

D: Max = 0.98 mm, Min = 0.92 mm
E: Max = 0.98 mm, Min = 0.92 mm

4225837/A 04/2020

NOTES:

- 1. All linear dimensions are in millimeters. Any dimensions in parenthesis are for reference only. Dimensioning and tolerancing per ASME Y14.5M.
- 2. This drawing is subject to change without notice.

EXAMPLE BOARD LAYOUT

YCK0009

DSBGA - 0.33 mm max height

DIE SIZE BALL GRID ARRAY

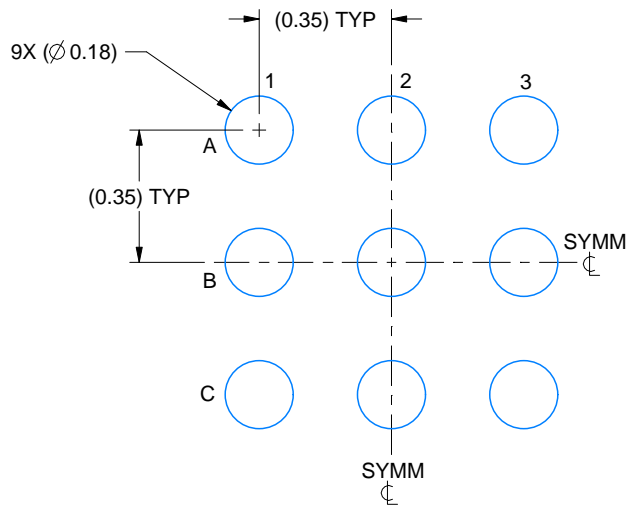

LAND PATTERN EXAMPLE
EXPOSED METAL SHOWN
SCALE: 50X

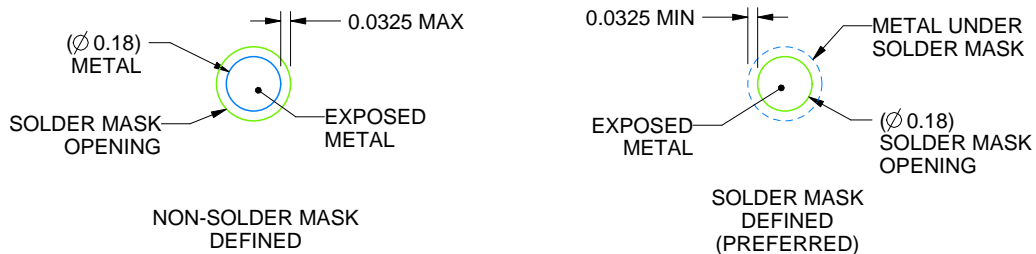

SOLDER MASK DETAILS
NOT TO SCALE

4225837/A 04/2020

NOTES: (continued)

- 3. Final dimensions may vary due to manufacturing tolerance considerations and also routing constraints. See Texas Instruments Literature No. SNVA009 (www.ti.com/lit/snva009).

EXAMPLE STENCIL DESIGN

YCK0009

DSBGA - 0.33 mm max height

DIE SIZE BALL GRID ARRAY

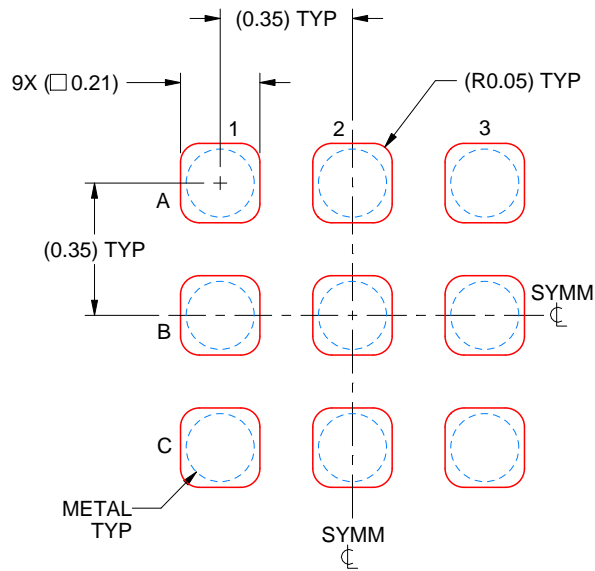

SOLDER PASTE EXAMPLE
BASED ON 0.075 mm THICK STENCIL
SCALE: 50X

4225837/A 04/2020

NOTES: (continued)

4. Laser cutting apertures with trapezoidal walls and rounded corners may offer better paste release.

EXAMPLE BOARD LAYOUT

DBV0006A

SOT-23 - 1.45 mm max height

SMALL OUTLINE TRANSISTOR

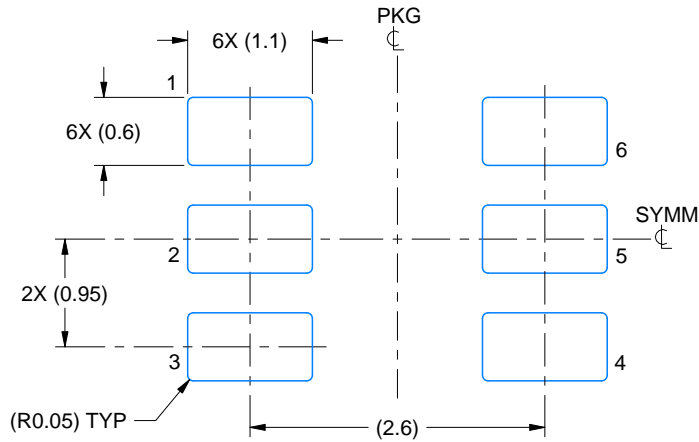

LAND PATTERN EXAMPLE
EXPOSED METAL SHOWN
SCALE:15X

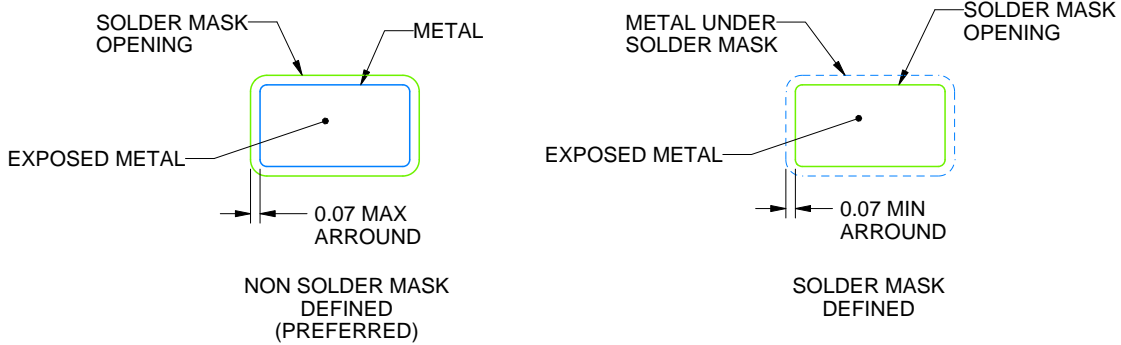

SOLDER MASK DETAILS

4214840/G 08/2024

NOTES: (continued)

6. Publication IPC-7351 may have alternate designs.

7. Solder mask tolerances between and around signal pads can vary based on board fabrication site.

EXAMPLE STENCIL DESIGN

DBV0006A

SOT-23 - 1.45 mm max height

SMALL OUTLINE TRANSISTOR

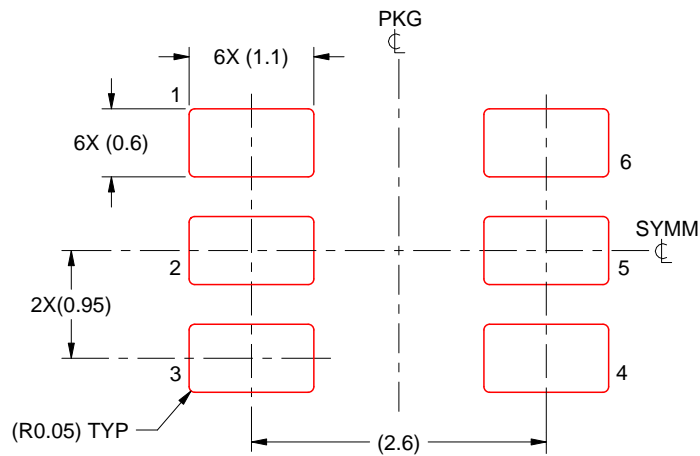

SOLDER PASTE EXAMPLE
BASED ON 0.125 mm THICK STENCIL
SCALE:15X

4214840/G 08/2024

NOTES: (continued)

8. Laser cutting apertures with trapezoidal walls and rounded corners may offer better paste release. IPC-7525 may have alternate design recommendations.
9. Board assembly site may have different recommendations for stencil design.

GENERIC PACKAGE VIEW

DSG 8

WSON - 0.8 mm max height

2 x 2, 0.5 mm pitch

PLASTIC SMALL OUTLINE - NO LEAD

This image is a representation of the package family, actual package may vary.
Refer to the product data sheet for package details.

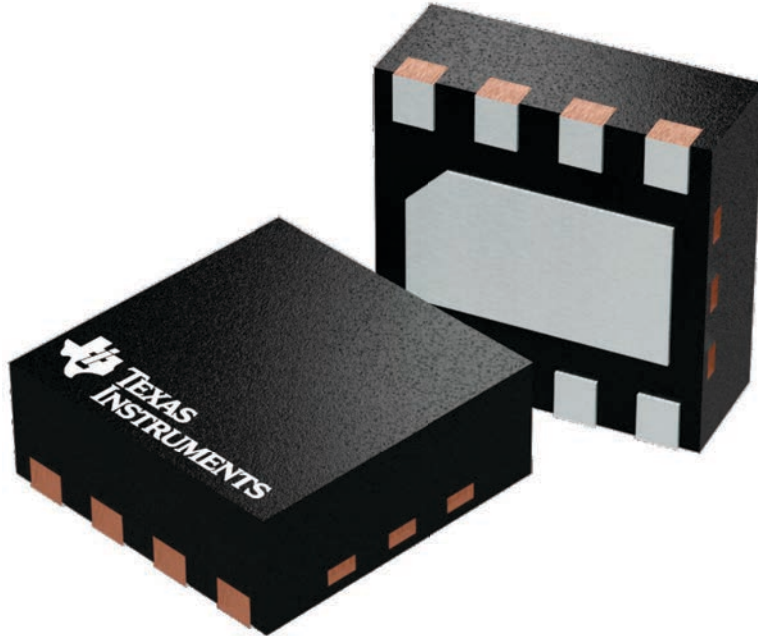

4224783/A

DSG0008A

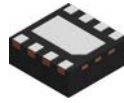

PACKAGE OUTLINE

WSON - 0.8 mm max height

PLASTIC SMALL OUTLINE - NO LEAD

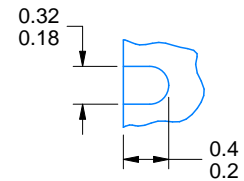
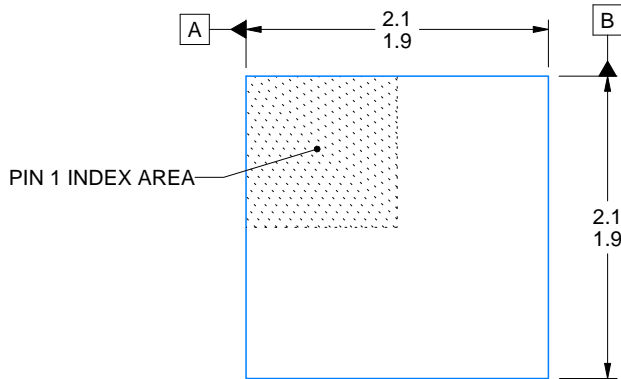

ALTERNATIVE TERMINAL SHAPE TYPICAL

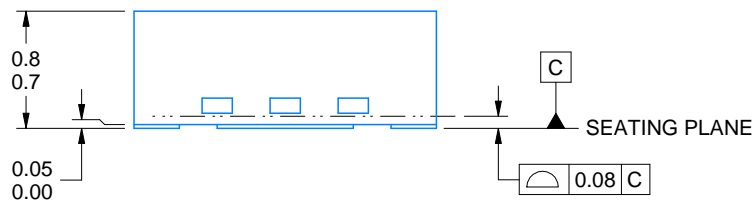

SIDE WALL METAL THICKNESS DIM A	
OPTION 1	OPTION 2
0.1	0.2

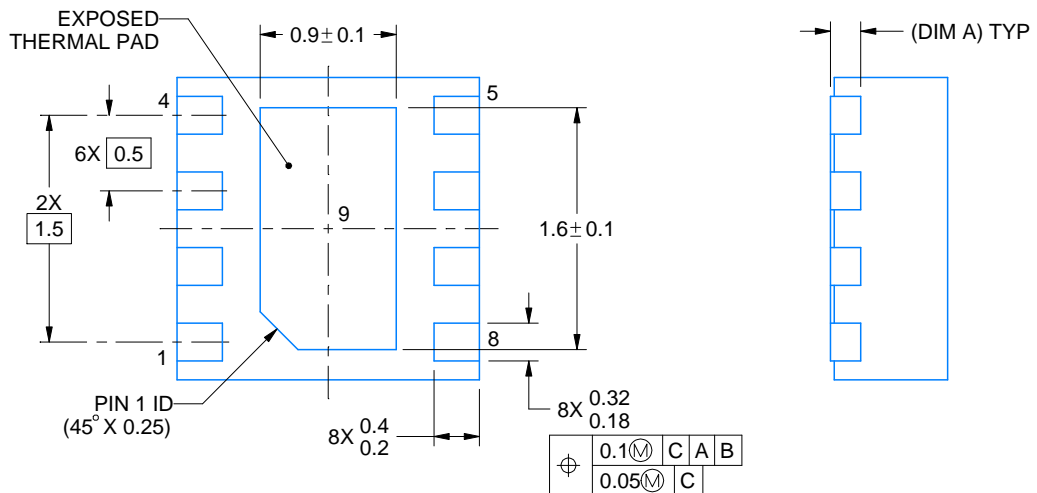

4218900/E 08/2022

NOTES:

1. All linear dimensions are in millimeters. Any dimensions in parenthesis are for reference only. Dimensioning and tolerancing per ASME Y14.5M.
2. This drawing is subject to change without notice.
3. The package thermal pad must be soldered to the printed circuit board for thermal and mechanical performance.

EXAMPLE BOARD LAYOUT

DSG0008A

WSON - 0.8 mm max height

PLASTIC SMALL OUTLINE - NO LEAD

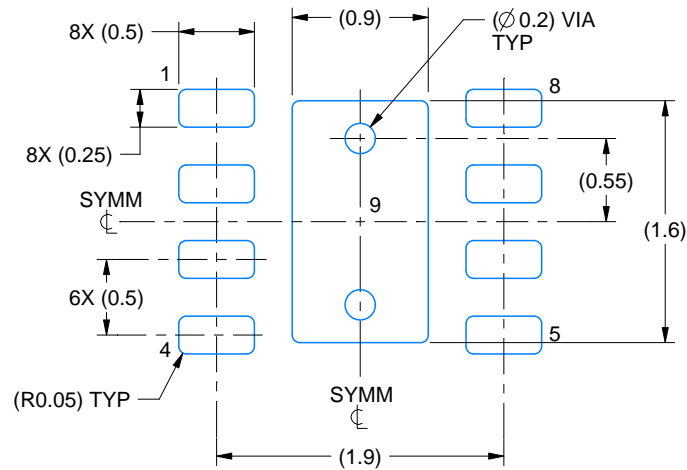

LAND PATTERN EXAMPLE
SCALE:20X

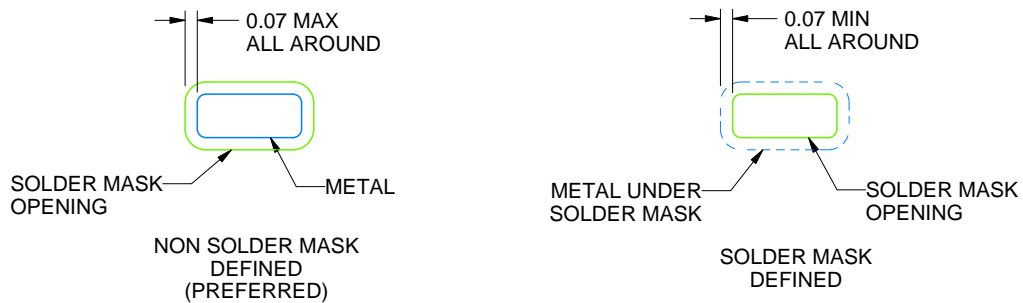

SOLDER MASK DETAILS

4218900/E 08/2022

NOTES: (continued)

4. This package is designed to be soldered to a thermal pad on the board. For more information, see Texas Instruments literature number SLUA271 (www.ti.com/lit/slua271).
5. Vias are optional depending on application, refer to device data sheet. If any vias are implemented, refer to their locations shown on this view. It is recommended that vias under paste be filled, plugged or tented.

EXAMPLE STENCIL DESIGN

DSG0008A

WSON - 0.8 mm max height

PLASTIC SMALL OUTLINE - NO LEAD

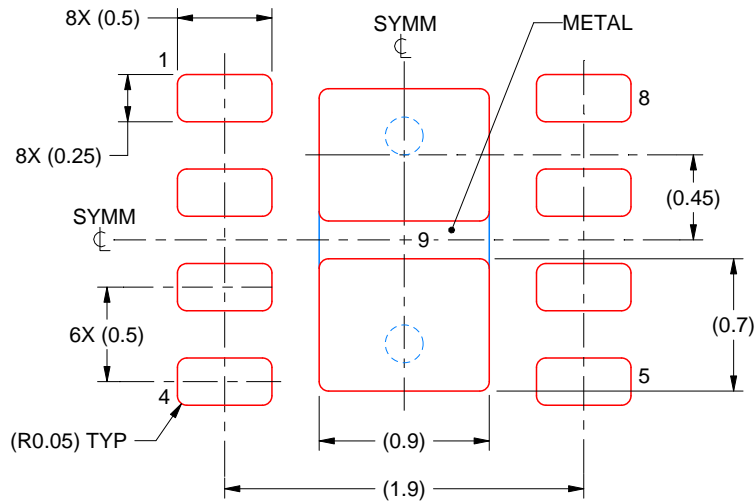

SOLDER PASTE EXAMPLE
BASED ON 0.125 mm THICK STENCIL

EXPOSED PAD 9:
87% PRINTED SOLDER COVERAGE BY AREA UNDER PACKAGE
SCALE:25X

4218900/E 08/2022

NOTES: (continued)

6. Laser cutting apertures with trapezoidal walls and rounded corners may offer better paste release. IPC-7525 may have alternate design recommendations.

PW0014A

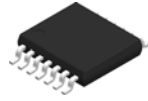

PACKAGE OUTLINE
TSSOP - 1.2 mm max height

SMALL OUTLINE PACKAGE

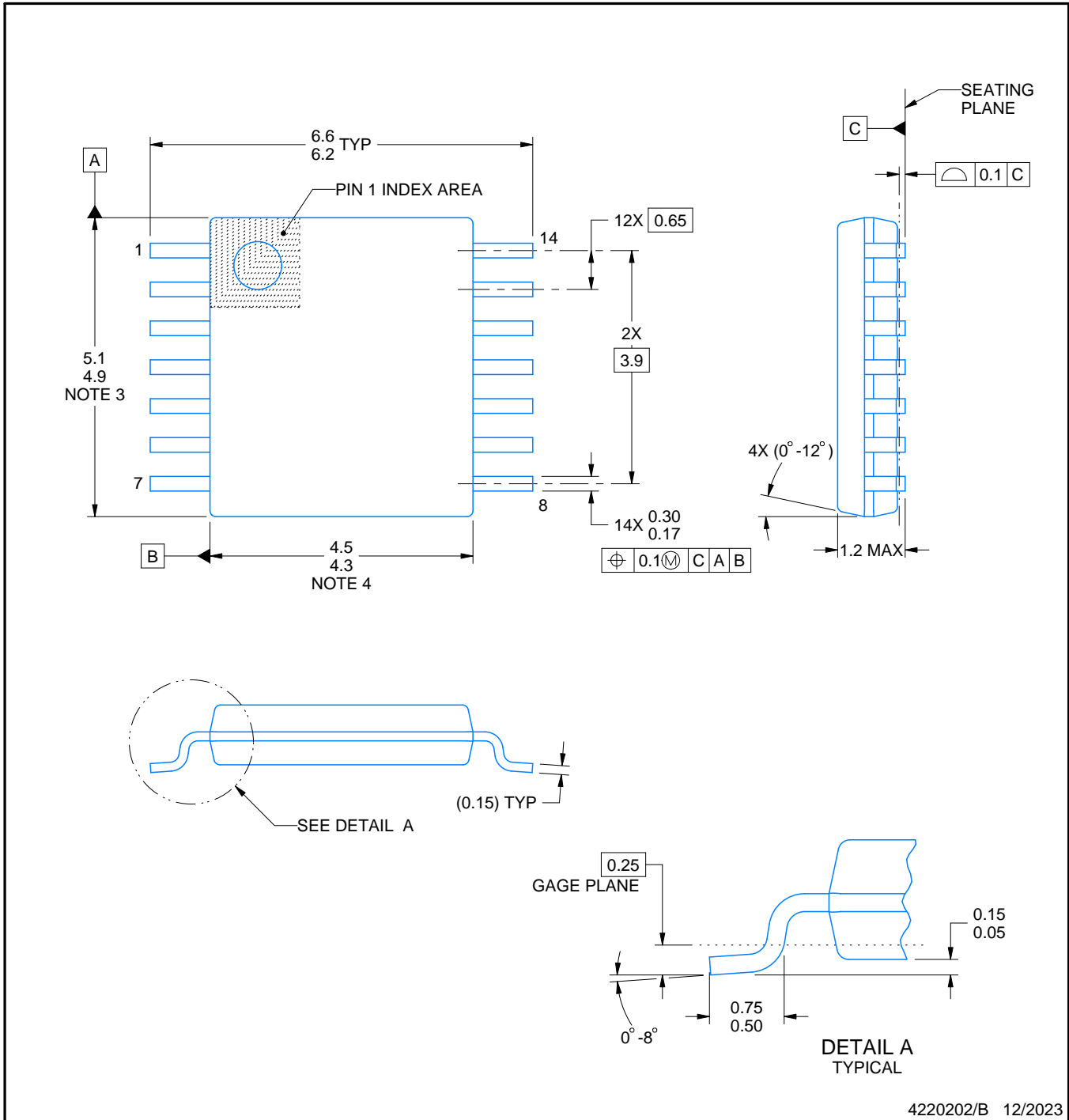

4220202/B 12/2023

NOTES:

1. All linear dimensions are in millimeters. Any dimensions in parenthesis are for reference only. Dimensioning and tolerancing per ASME Y14.5M.
2. This drawing is subject to change without notice.
3. This dimension does not include mold flash, protrusions, or gate burrs. Mold flash, protrusions, or gate burrs shall not exceed 0.15 mm per side.
4. This dimension does not include interlead flash. Interlead flash shall not exceed 0.25 mm per side.
5. Reference JEDEC registration MO-153.

EXAMPLE BOARD LAYOUT

PW0014A

TSSOP - 1.2 mm max height

SMALL OUTLINE PACKAGE

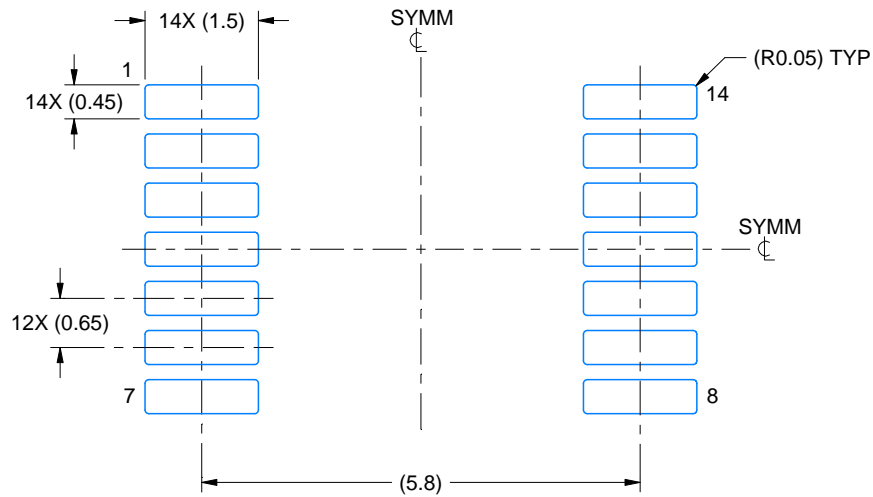

LAND PATTERN EXAMPLE
EXPOSED METAL SHOWN
SCALE: 10X

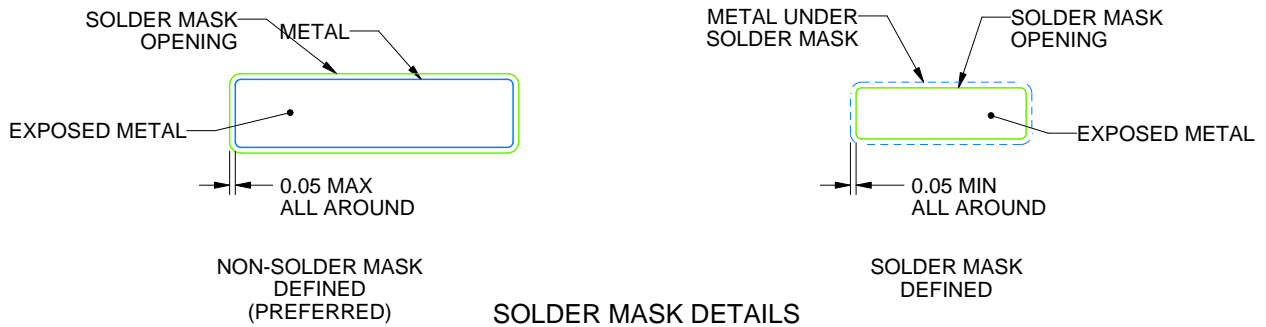

4220202/B 12/2023

NOTES: (continued)

- 6. Publication IPC-7351 may have alternate designs.
- 7. Solder mask tolerances between and around signal pads can vary based on board fabrication site.

EXAMPLE STENCIL DESIGN

PW0014A

TSSOP - 1.2 mm max height

SMALL OUTLINE PACKAGE

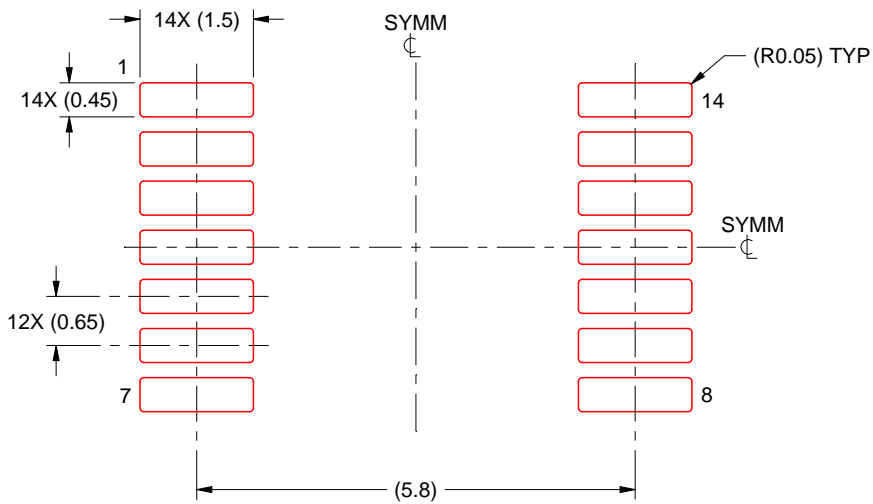

SOLDER PASTE EXAMPLE
BASED ON 0.125 mm THICK STENCIL
SCALE: 10X

4220202/B 12/2023

NOTES: (continued)

8. Laser cutting apertures with trapezoidal walls and rounded corners may offer better paste release. IPC-7525 may have alternate design recommendations.
9. Board assembly site may have different recommendations for stencil design.

PW0008A



PACKAGE OUTLINE
TSSOP - 1.2 mm max height

SMALL OUTLINE PACKAGE

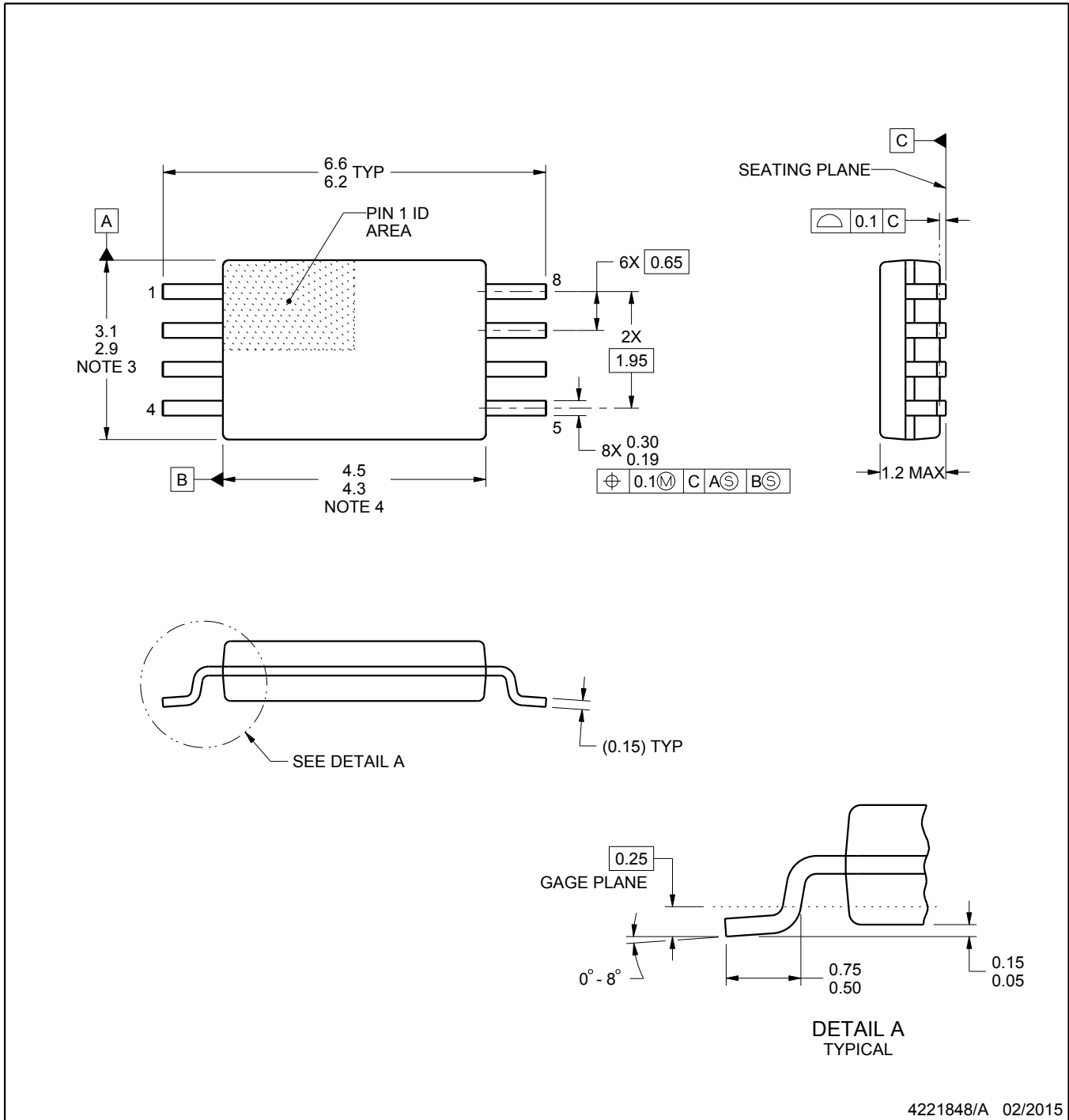

4221848/A 02/2015

NOTES:

1. All linear dimensions are in millimeters. Any dimensions in parenthesis are for reference only. Dimensioning and tolerancing per ASME Y14.5M.
2. This drawing is subject to change without notice.
3. This dimension does not include mold flash, protrusions, or gate burrs. Mold flash, protrusions, or gate burrs shall not exceed 0.15 mm per side.
4. This dimension does not include interlead flash. Interlead flash shall not exceed 0.25 mm per side.
5. Reference JEDEC registration MO-153, variation AA.

EXAMPLE BOARD LAYOUT

PW0008A

TSSOP - 1.2 mm max height

SMALL OUTLINE PACKAGE

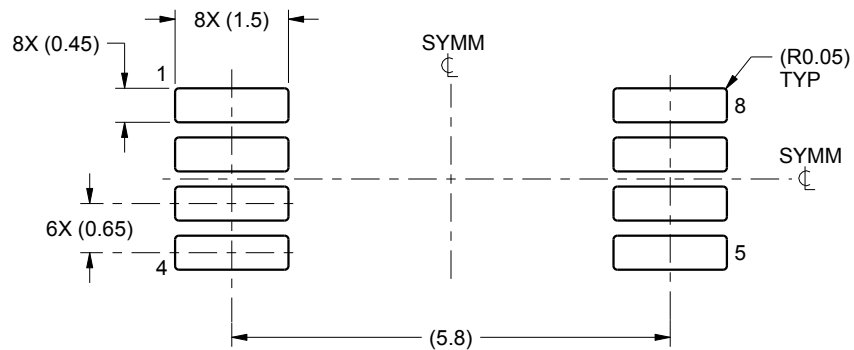

LAND PATTERN EXAMPLE
SCALE:10X

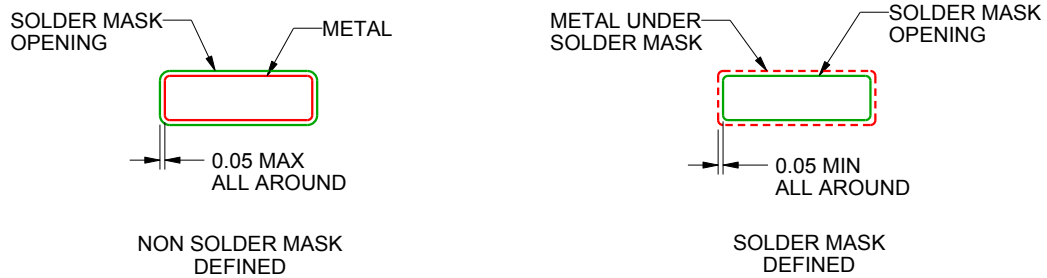

SOLDER MASK DETAILS
NOT TO SCALE

4221848/A 02/2015

NOTES: (continued)

- 6. Publication IPC-7351 may have alternate designs.
- 7. Solder mask tolerances between and around signal pads can vary based on board fabrication site.

EXAMPLE STENCIL DESIGN

PW0008A

TSSOP - 1.2 mm max height

SMALL OUTLINE PACKAGE

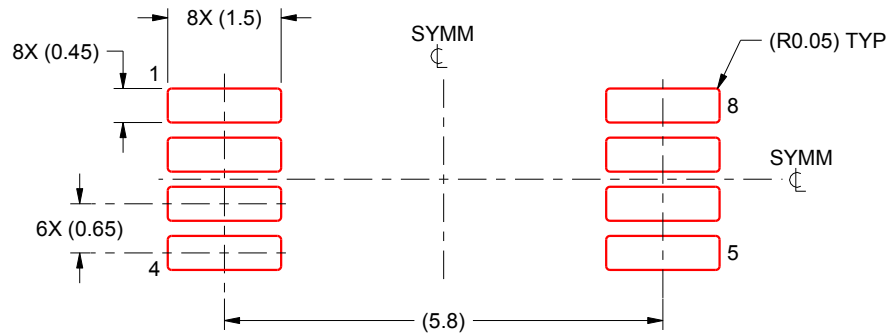

SOLDER PASTE EXAMPLE
BASED ON 0.125 mm THICK STENCIL
SCALE:10X

4221848/A 02/2015

NOTES: (continued)

8. Laser cutting apertures with trapezoidal walls and rounded corners may offer better paste release. IPC-7525 may have alternate design recommendations.
9. Board assembly site may have different recommendations for stencil design.

GENERIC PACKAGE VIEW

RUC 14

X2QFN - 0.4 mm max height

2 x 2, 0.4 mm pitch

PLASTIC QUAD FLATPACK - NO LEAD

This image is a representation of the package family, actual package may vary.
Refer to the product data sheet for package details.

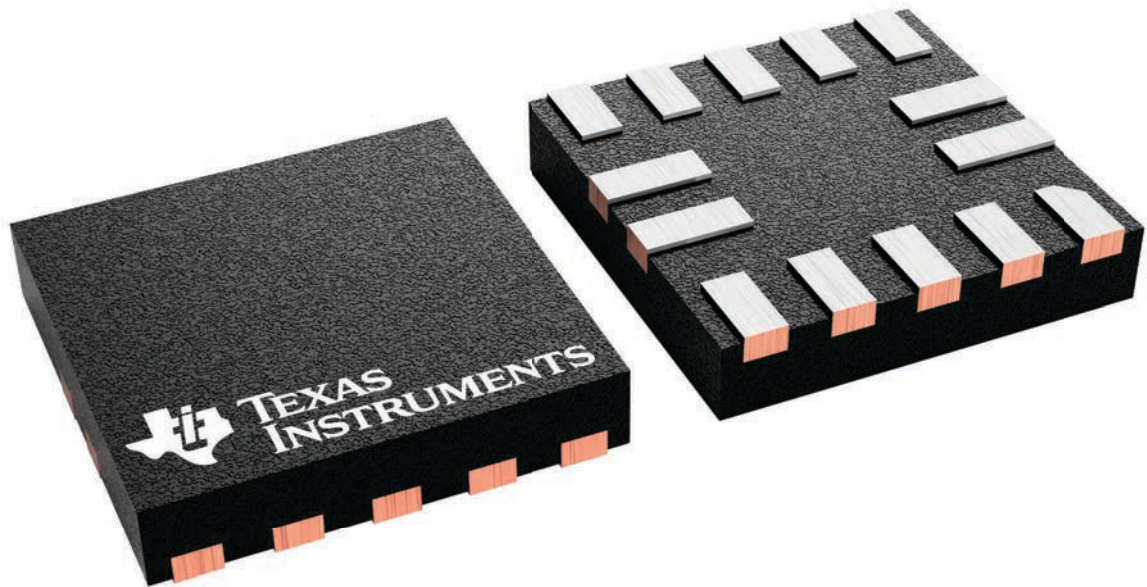

4229871/A

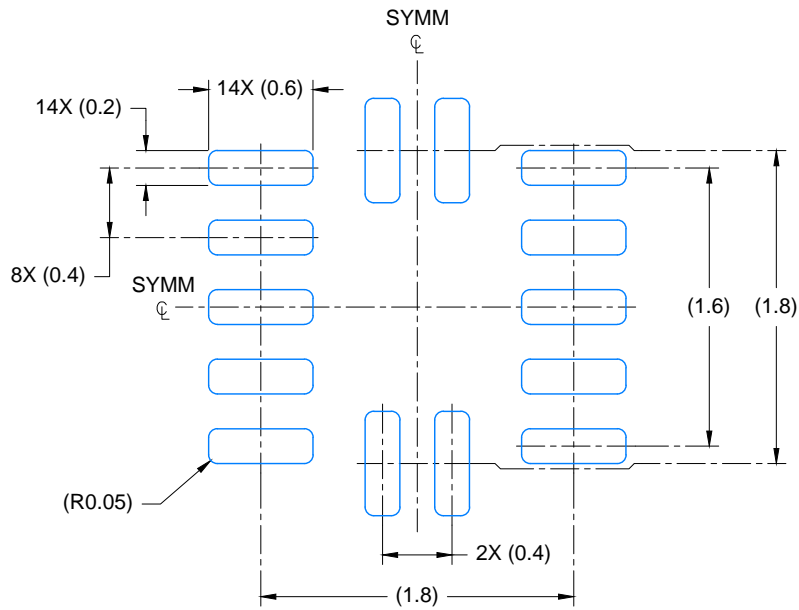

LAND PATTERN EXAMPLE
EXPOSED METAL SHOWN
SCALE: 23X

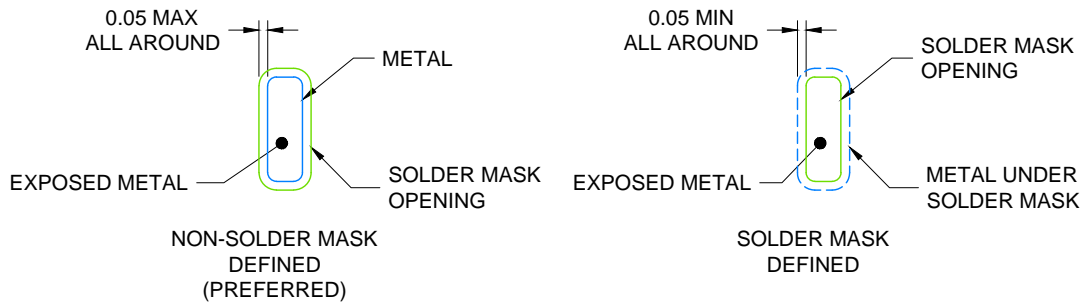

SOLDER MASK DETAILS

4220584/A 05/2019

NOTES: (continued)

- For more information, see Texas Instruments literature number SLUA271 (www.ti.com/lit/slua271).

EXAMPLE STENCIL DESIGN

RUC0014A

X2QFN - 0.4 mm max height

PLASTIC QUAD FLAT PACK- NO LEAD

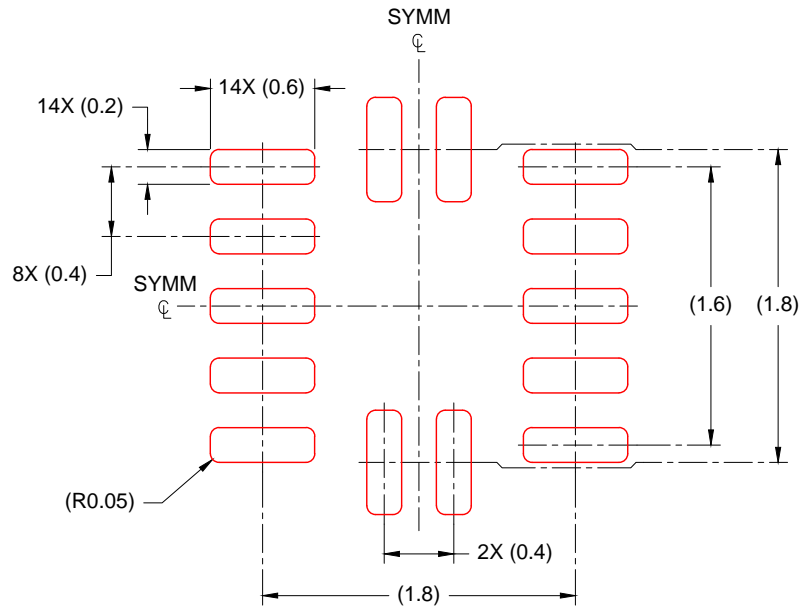

SOLDER PASTE EXAMPLE
BASED ON 0.100mm THICK STENCIL
SCALE: 23X

4220584/A 05/2019

NOTES: (continued)

4. Laser cutting apertures with trapezoidal walls and rounded corners may offer better paste release. IPC-7525 may have alternate design recommendations.

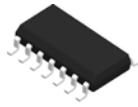

D0014A

PACKAGE OUTLINE

SOIC - 1.75 mm max height

SMALL OUTLINE INTEGRATED CIRCUIT

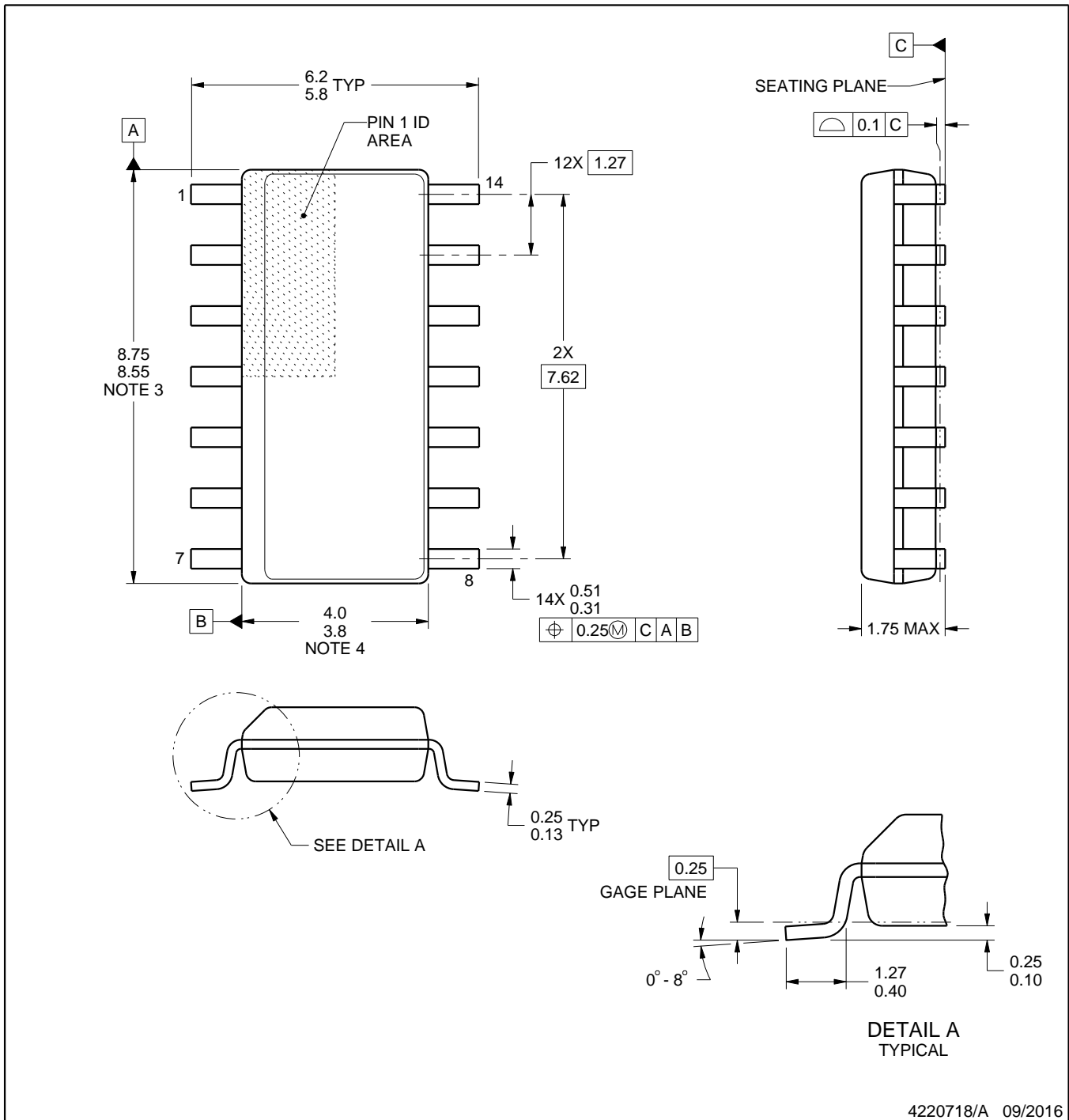

4220718/A 09/2016

NOTES:

1. All linear dimensions are in millimeters. Dimensions in parenthesis are for reference only. Dimensioning and tolerancing per ASME Y14.5M.
2. This drawing is subject to change without notice.
3. This dimension does not include mold flash, protrusions, or gate burrs. Mold flash, protrusions, or gate burrs shall not exceed 0.15 mm, per side.
4. This dimension does not include interlead flash. Interlead flash shall not exceed 0.43 mm, per side.
5. Reference JEDEC registration MS-012, variation AB.

EXAMPLE BOARD LAYOUT

D0014A

SOIC - 1.75 mm max height

SMALL OUTLINE INTEGRATED CIRCUIT

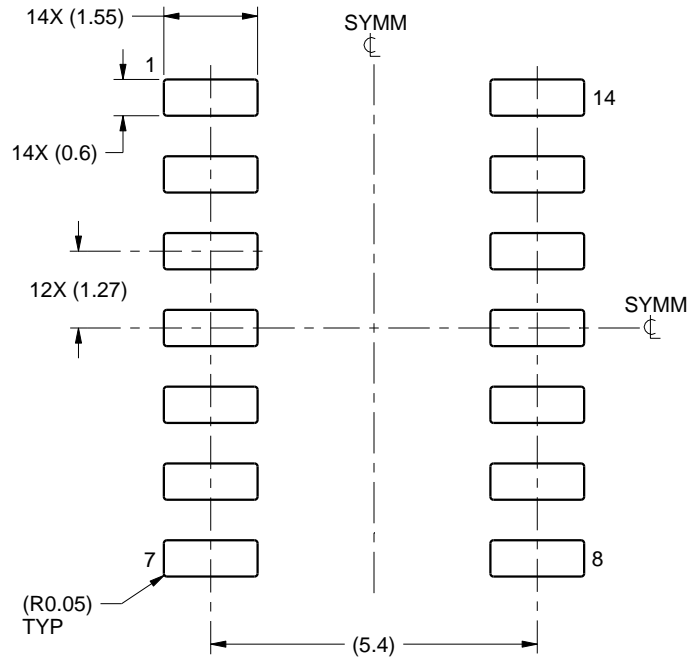

LAND PATTERN EXAMPLE
SCALE:8X

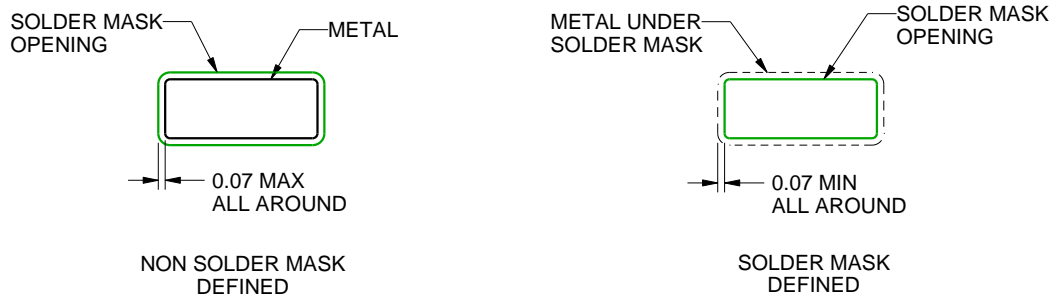

SOLDER MASK DETAILS

4220718/A 09/2016

NOTES: (continued)

- 6. Publication IPC-7351 may have alternate designs.
- 7. Solder mask tolerances between and around signal pads can vary based on board fabrication site.

EXAMPLE STENCIL DESIGN

D0014A

SOIC - 1.75 mm max height

SMALL OUTLINE INTEGRATED CIRCUIT

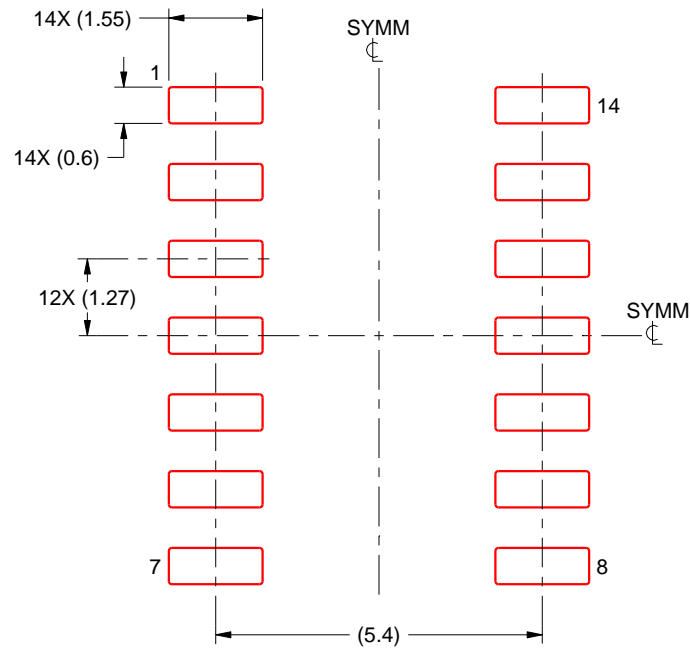

SOLDER PASTE EXAMPLE
BASED ON 0.125 mm THICK STENCIL
SCALE:8X

4220718/A 09/2016

NOTES: (continued)

8. Laser cutting apertures with trapezoidal walls and rounded corners may offer better paste release. IPC-7525 may have alternate design recommendations.
9. Board assembly site may have different recommendations for stencil design.

GENERIC PACKAGE VIEW

RUG 10

X2QFN - 0.4 mm max height

1.5 x 2, 0.5 mm pitch

PLASTIC QUAD FLATPACK - NO LEAD

This image is a representation of the package family, actual package may vary.
Refer to the product data sheet for package details.

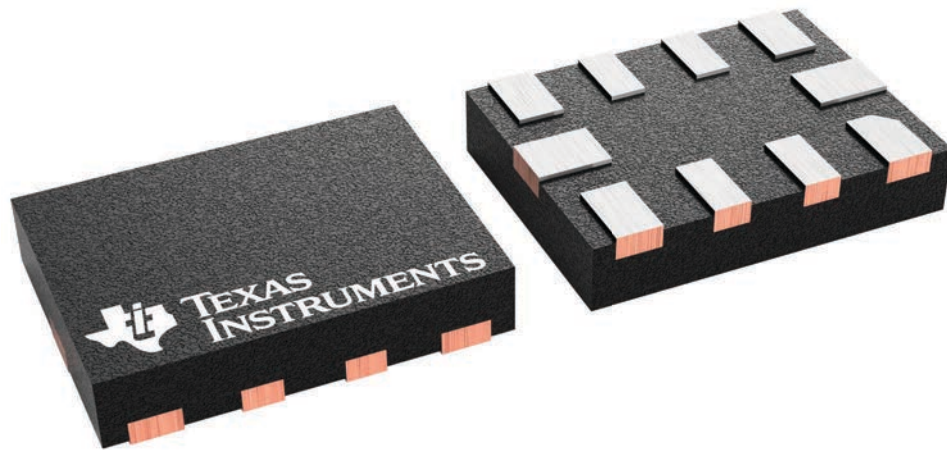

4231768/A

RUG0010A

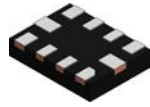

PACKAGE OUTLINE

X2QFN - 0.4 mm max height

PLASTIC QUAD FLATPACK - NO LEAD

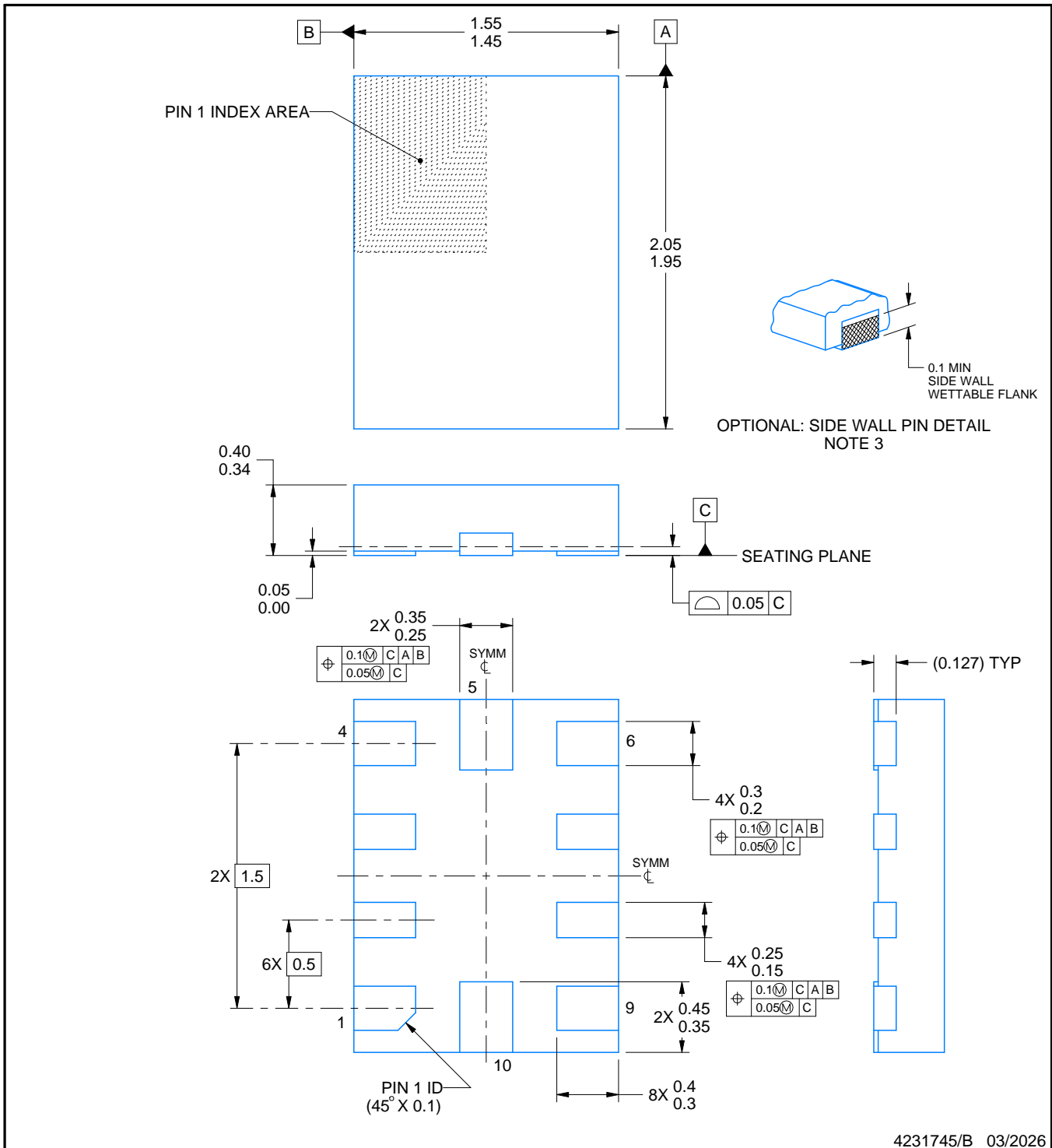

4231745/B 03/2026

NOTES:

1. All linear dimensions are in millimeters. Any dimensions in parenthesis are for reference only. Dimensioning and tolerancing per ASME Y14.5M.
2. This drawing is subject to change without notice.
3. Minimum 0.1 mm solder wetting on pin side wall. Available for wettable flank version only.

EXAMPLE BOARD LAYOUT

RUG0010A

X2QFN - 0.4 mm max height

PLASTIC QUAD FLATPACK - NO LEAD

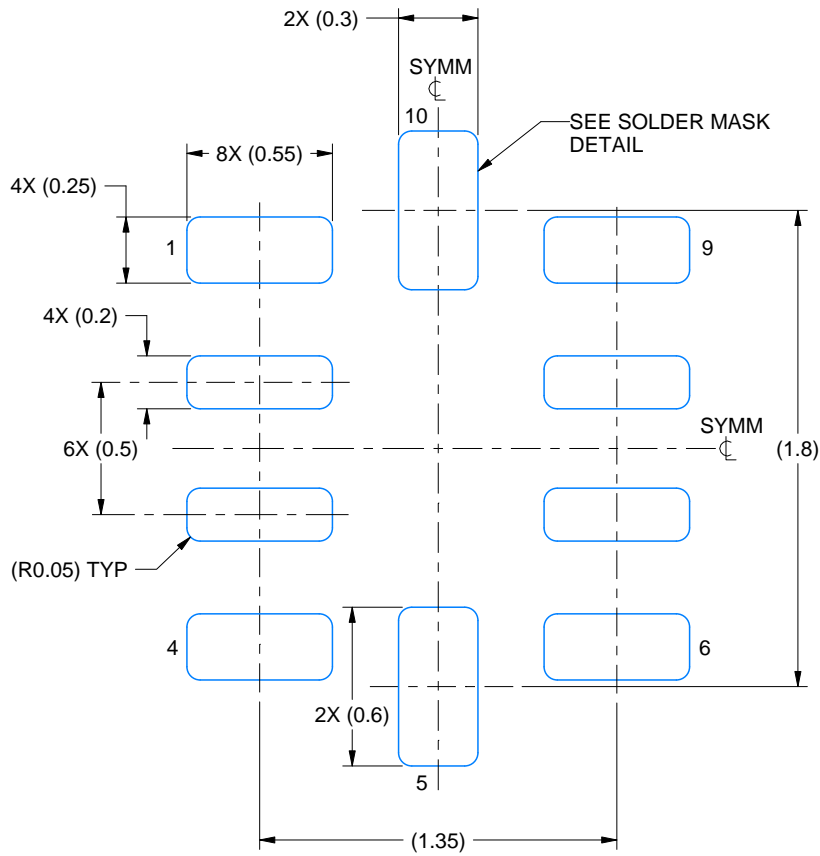

LAND PATTERN EXAMPLE
EXPOSED METAL SHOWN
SCALE: 35X

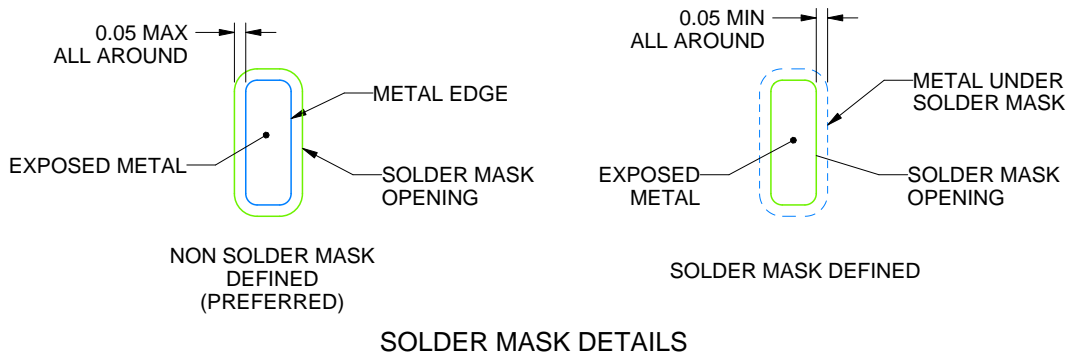

4231745/B 03/2026

NOTES: (continued)

3. For more information, see Texas Instruments literature number SLUA271 (www.ti.com/lit/sluea271).

重要通知和免责声明

TI“按原样”提供技术和可靠性数据（包括数据表）、设计资源（包括参考设计）、应用或其他设计建议、网络工具、安全信息和其他资源，不保证没有瑕疵且不做任何明示或暗示的担保，包括但不限于对适销性、与某特定用途的适用性或不侵犯任何第三方知识产权的暗示担保。

这些资源可供使用 TI 产品进行设计的熟练开发人员使用。您将自行承担以下全部责任：(1) 针对您的应用选择合适的 TI 产品，(2) 设计、验证并测试您的应用，(3) 确保您的应用满足相应标准以及任何其他安全、安保法规或其他要求。

这些资源如有变更，恕不另行通知。TI 授权您仅可将这些资源用于研发本资源所述的 TI 产品的相关应用。严禁以其他方式对这些资源进行复制或展示。您无权使用任何其他 TI 知识产权或任何第三方知识产权。对于因您对这些资源的使用而对 TI 及其代表造成的任何索赔、损害、成本、损失和债务，您将全额赔偿，TI 对此概不负责。

TI 提供的产品受 [TI 销售条款](#)、[TI 通用质量指南](#) 或 [ti.com](#) 上其他适用条款或 TI 产品随附的其他适用条款的约束。TI 提供这些资源并不会扩展或以其他方式更改 TI 针对 TI 产品发布的适用的担保或担保免责声明。除非德州仪器 (TI) 明确将某产品指定为定制产品或客户特定产品，否则其产品均为按确定价格收入目录的标准通用器件。

TI 反对并拒绝您可能提出的任何其他或不同的条款。

版权所有 © 2026，德州仪器 (TI) 公司

最后更新日期：2025 年 10 月