

TL431、TL432 精密可编程基准

1 特性

- 25°C 下的基准电压容差
 - 0.5% (B 级)
 - 1% (A 级)
 - 2% (标准级)
- 可调节输出电压： V_{ref} 至 36V
- 工作温度范围：-40°C 至 125°C
- 典型温度漂移 (TL43xB)
 - 6mV (C 级温度)
 - 14mV (I 级温度, Q 级温度)
- 低输出噪声
- 输出阻抗典型值为 0.2 Ω
- 灌电流能力：1mA 至 100mA

2 应用

- 机架服务器电源
- 工业交流/直流电源
- 交流逆变器和变频驱动器
- 伺服驱动器控制模块
- 笔记本电脑电源适配器设计

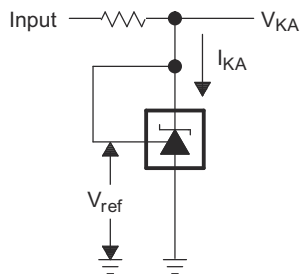

简化原理图

3 说明

TL431 和 TL432 器件是三端可调节并联稳压器，在适用的汽车级、商用级和军用级温度范围内均可满足规定的热稳定性。可以通过两个外部电阻器将输出电压设置为介于 V_{ref} (约为

2.5V) 和 36V 之间的任意值。这些器件的输出阻抗典型值为 0.2 Ω 。此类器件的有源输出电路具有非常明显的导通特性，因此非常适合用于替代许多应用中的齐纳二极管，例如板载稳压器、可调节电源和开关电源。

TL432 器件具有与 TL431 器件完全相同的功能和电气特性，但是具有不同的 DBV、DBZ 和 PK 封装引脚排列。

TL431 和 TL432 器件都具有 B、A 和标准三个等级，25°C 下的初始容差分别为 0.5%、1% 和 2%。此外，低输出温漂验证了在整个温度范围内具有出色的稳定性。

TL43xxC 器件运行温度范围为 0°C 至 70°C，TL43xxI 器件运行温度范围为 -40°C 至 85°C，TL43xxQ 器件运行温度范围为 -40°C 至 125°C。

器件信息

器件型号	封装 (引脚) ⁽¹⁾	本体尺寸 (标称值) ⁽²⁾
TL43x	SOT-23-3 (3)	2.90mm × 1.30mm
	SOT-23-5 (5)	2.90mm × 1.60mm
	SOIC (8)	4.90mm × 3.90mm
	PDIP (8)	9.50mm × 6.35mm
	SOP (8)	6.20mm × 5.30mm

(1) 如需了解所有可用封装，请参阅数据表末尾的可订购产品附录。

(2) 封装尺寸 (长 × 宽) 为标称值，并包括引脚 (如适用)。



内容

1 特性	1	7.2 动态阻抗.....	21
2 应用	1	8 详细说明	22
3 说明	1	8.1 概述.....	22
4 器件比较表	3	8.2 功能方框图.....	22
5 引脚配置和功能	4	8.3 特性说明.....	23
6 规格	6	8.4 器件功能模式.....	23
6.1 绝对最大额定值.....	6	9 应用和实现	24
6.2 ESD 等级.....	6	9.1 应用信息.....	24
6.3 热性能信息.....	6	9.2 典型应用.....	24
6.4 建议运行条件.....	6	9.3 系统示例.....	29
6.5 电气特性, TL431C、TL432C.....	7	9.4 电源相关建议.....	32
6.6 电气特性, TL431I、TL432I.....	8	9.5 布局.....	32
6.7 电气特性, TL431Q、TL432Q.....	9	10 器件和文档支持	33
6.8 电气特性, TL431AC、TL432AC.....	10	10.1 器件命名规则.....	33
6.9 电气特性, TL431AI、TL432AI.....	11	10.2 相关链接.....	33
6.10 电气特性, TL431AQ、TL432AQ.....	12	10.3 接收文档更新通知.....	33
6.11 电气特性, TL431BC、TL432BC.....	13	10.4 支持资源.....	33
6.12 电气特性, TL431BI、TL432BI.....	14	10.5 商标.....	33
6.13 电气特性, TL431BQ、TL432BQ.....	15	10.6 静电放电警告.....	34
6.14 典型特性.....	16	10.7 术语表.....	34
7 参数测量信息	20	11 修订历史记录	34
7.1 温度系数.....	20	12 机械、封装和可订购信息	34

4 器件比较表

器件引脚分配	初始精度	自然通风条件下的工作温度 (T _A)
TL431 TL432	B : 0.5% A : 1% (空白) : 2%	C : 0°C 至 70°C I : -40°C 至 85°C Q : -40°C 至 125°C

5 引脚配置和功能

TL431, TL431A, TL431B ... LP (TO-92/TO-226) PACKAGE
(TOP VIEW)

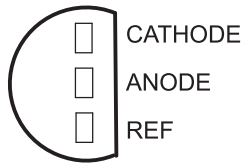

TL431A, TL431B ... DCK (SC-70) PACKAGE
(TOP VIEW)

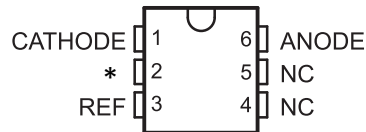

NC - No internal connection

* - Must be connected to ANODE or left open

TL431, TL431A, TL431B ... D (SOIC) PACKAGE
(TOP VIEW)

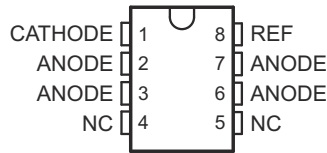

NC - No internal connection

TL431, TL431A, TL431B ... P (PDIP), PS (SOP),
OR PW (TSSOP) PACKAGE
(TOP VIEW)

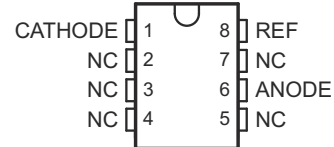

NC - No internal connection

TL431, TL431A, TL431B ... PK (SOT-89) PACKAGE
(TOP VIEW)

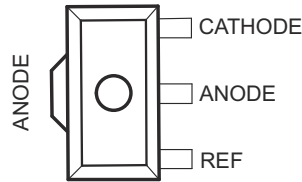

TL432, TL432A, TL432B ... PK (SOT-89) PACKAGE
(TOP VIEW)

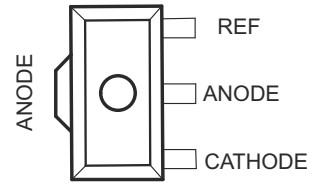

TL431, TL431A, TL431B ... DBV (SOT-23-5) PACKAGE
(TOP VIEW)



NC - No internal connection

† Pin 2 is attached to Substrate and must be connected to ANODE or left open.

TL432, TL432A, TL432B ... DBV (SOT-23-5) PACKAGE
(TOP VIEW)

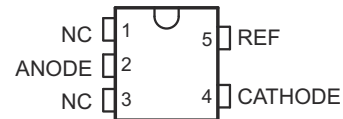

NC - No internal connection

TL431, TL431A, TL431B ... DBZ (SOT-23-3) PACKAGE
(TOP VIEW)

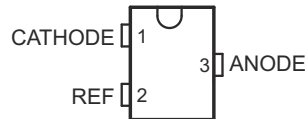

TL432, TL432A, TL432B ... DBZ (SOT-23-3) PACKAGE
(TOP VIEW)



表 5-1. 引脚功能

名称	引脚										类型	说明
	TL431x					TL432x						
	DBZ	DBV	PK	D	P、PS PW	LP	DCK	DBZ	DBV	PK		
CATHODE	1	3	3	1	1	1	1	2	4	1	I/O	并联电流/电压输入
REF	2	4	1	8	8	3	3	1	5	3	I	相对于通用阳极的阈值

表 5-1. 引脚功能 (续)

引脚											类型	说明
名称	TL431x							TL432x				
	DBZ	DBV	PK	D	P、PS PW	LP	DCK	DBZ	DBV	PK		
ANODE	3	5	2	2、3、 6、7	6	2	6	3	2	2	O	通用引脚，通常接地

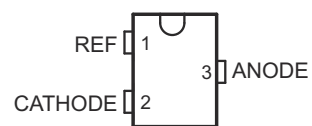
6 规格

6.1 绝对最大额定值

在自然通风条件下的工作温度范围内测得 (除非另有说明) ⁽¹⁾

		最小值	最大值	单位
V _{KA}	阴极电压 ⁽²⁾		37	V
I _{KA}	连续阴极电流范围	- 100	150	mA
I _{I(ref)}	基准输入电流	- 0.05	10	mA
T _J	工作结温范围		150	°C
T _{stg}	贮存温度范围	- 65	150	°C

- (1) 应力超出绝对最大额定值下列出的值可能会对器件造成永久损坏。这些列出的值仅仅是应力等级, 这并不表示器件在这些条件下以及在建议运行条件以外的任何其他条件下能够正常运行。长时间处于绝对最大额定条件下可能会影响器件的可靠性。
- (2) 除非另有说明, 否则所有电压值均以 ANODE 为基准。

6.2 ESD 等级

			值	单位
V _(ESD)	静电放电	人体放电模型 (HBM), 符合 ANSI/ESDA/JEDEC JS-001 引脚 ⁽¹⁾	±2000	V
		充电器件模型 (CDM), 符合 JEDEC 规范 JESD22-C101 标准 ⁽²⁾	±1000	

- (1) JEDEC 文档 JEP155 指出: 500V HBM 时能够在标准 ESD 控制流程下安全生产。若部署必要的预防措施, 不足 500V HBM 时也能进行生产。
- (2) JEDEC 文档 JEP157 指出: 250V CDM 时能够在标准 ESD 控制流程下安全生产。若部署必要的预防措施, 不足 250V CDM 时也能进行生产。

6.3 热性能信息

热指标 ⁽¹⁾		TL43xx									单位
		P	PW	D	PS	DCK	DBV	DBZ	LP	PK	
		8 引脚			6 引脚	5 引脚	3 引脚				
R _{θJA}	结至环境热阻	85	149	97	95	259	206	206	140	52	°C/W
R _{θJC(top)}	结至外壳 (顶部) 热阻	57	65	39	46	87	131	76	55	9	°C/W

- (1) 有关新旧热指标的更多信息, 请参阅 IC 封装热指标应用报告 (SPRA953)。

6.4 建议运行条件

请参阅⁽¹⁾

		最小值	最大值	单位
V _{KA}	阴极电压	V _{ref}	36	V
I _{KA}	连续阴极电流范围	1	100	mA
T _A	自然通风条件下的工作温度范围	TL43xxC	0	70
		TL43xxI	-40	85
		TL43xxQ	-40	125

- (1) 最大功耗是与 T_{J(max)}、R_{θJA} 和 T_A 相关的函数。在任何允许的环境温度下, 允许的最大功耗为 P_D = (T_{J(max)} - T_A) / R_{θJA}。在 150°C 的绝对最大 T_J 下运行可能会影响可靠性。

6.5 电气特性, TL431C、TL432C

在推荐的工作条件下测得, $T_A = 25^\circ\text{C}$ (除非另有说明)

参数		测试电路	测试条件	最小值	典型值	最大值	单位
V_{ref}	基准电压	请参阅图 7-1	$V_{\text{KA}} = V_{\text{ref}}, I_{\text{KA}} = 10\text{mA}$	2440	2495	2550	mV
$V_{\text{I(dev)}}$	整个温度范围内的基准输入电压偏差 (1)	请参阅图 7-1	$V_{\text{KA}} = V_{\text{ref}}, I_{\text{KA}} = 10\text{mA}$	SOT23-3 和 TL432 器件	6	16	mV
				所有其他器件	4	25	mV
$\Delta V_{\text{ref}} / \Delta V_{\text{KA}}$	基准电压变化与阴极电压变化之比	请参阅图 7-2	$I_{\text{KA}} = 10\text{mA}$	$\Delta V_{\text{KA}} = 10\text{V} - V_{\text{ref}}$	-1.4	-2.7	mV/V
				$\Delta V_{\text{KA}} = 36\text{V} - 10\text{V}$	-1	-2	mV/V
I_{ref}	基准输入电流	请参阅图 7-2	$I_{\text{KA}} = 10\text{mA}, R1 = 10\text{k}\Omega, R2 = \infty$		2	4	μA
$I_{\text{I(dev)}}$	整个温度范围内的基准输入电流偏差 (1)	请参阅图 7-2	$I_{\text{KA}} = 10\text{mA}, R1 = 10\text{k}\Omega, R2 = \infty$		0.4	1.2	μA
I_{min}	调节的最小阴极电流	请参阅图 7-1	$V_{\text{KA}} = V_{\text{ref}}$		0.4	1	mA
I_{off}	关闭状态阴极电流	请参阅图 7-3	$V_{\text{KA}} = 36\text{V}, V_{\text{ref}} = 0$		0.1	1	μA
$ Z_{\text{KA}} $	动态阻抗 (2)	请参阅图 7-1	$V_{\text{KA}} = V_{\text{ref}}, f \leq 1\text{kHz}, I_{\text{KA}} = 1\text{mA}$ 至 100mA		0.2	0.5	Ω

- (1) 偏差参数 $V_{\text{I(dev)}}$ 和 $I_{\text{I(dev)}}$ 是指在额定温度范围内获得的最大和最小值之间的差异。有关 $V_{\text{I(dev)}}$ 的更多详细信息及其与平均温度系数的关系, 请参阅温度系数。
- (2) 动态阻抗被定义为: $|Z_{\text{KA}}| = \Delta V_{\text{KA}} / \Delta I_{\text{KA}}$ 。有关 $|Z_{\text{KA}}|$ 的更多详细信息及其与 V_{KA} 的关系, 请参阅动态阻抗。

6.6 电气特性, TL431I、TL432I

在推荐的工作条件下测得, $T_A = 25^\circ\text{C}$ (除非另有说明)

参数		测试电路	测试条件	最小值	典型值	最大值	单位
V_{ref}	基准电压	请参阅图 7-1	$V_{\text{KA}} = V_{\text{ref}}, I_{\text{KA}} = 10\text{mA}$	2440	2495	2550	mV
$V_{\text{I(dev)}}$	整个温度范围内的基准输入电压偏差 (1)	请参阅图 7-1	$V_{\text{KA}} = V_{\text{ref}}, I_{\text{KA}} = 10\text{mA}$	SOT23-3 和 TL432 器件	14	34	mV
				所有其他器件	5	50	mV
$\Delta V_{\text{ref}} / \Delta V_{\text{KA}}$	基准电压变化与阴极电压变化之比	请参阅图 7-2	$I_{\text{KA}} = 10\text{mA}$	$\Delta V_{\text{KA}} = 10\text{V} - V_{\text{ref}}$	-1.4	-2.7	mV/V
				$\Delta V_{\text{KA}} = 36\text{V} - 10\text{V}$	-1	-2	mV/V
I_{ref}	基准输入电流	请参阅图 7-2	$I_{\text{KA}} = 10\text{mA}, R1 = 10\text{k}\Omega, R2 = \infty$		2	4	μA
$I_{\text{I(dev)}}$	整个温度范围内的基准输入电流偏差 (1)	请参阅图 7-2	$I_{\text{KA}} = 10\text{mA}, R1 = 10\text{k}\Omega, R2 = \infty$		0.8	2.5	μA
I_{min}	调节的最小阴极电流	请参阅图 7-1	$V_{\text{KA}} = V_{\text{ref}}$		0.4	1	mA
I_{off}	关闭状态阴极电流	请参阅图 7-3	$V_{\text{KA}} = 36\text{V}, V_{\text{ref}} = 0$		0.1	1	μA
$ Z_{\text{KA}} $	动态阻抗 (2)	请参阅图 7-1	$V_{\text{KA}} = V_{\text{ref}}, f \leq 1\text{kHz}, I_{\text{KA}} = 1\text{mA}$ 至 100mA		0.2	0.5	Ω

- (1) 偏差参数 $V_{\text{I(dev)}}$ 和 $I_{\text{I(dev)}}$ 是指在额定温度范围内获得的最大和最小值之间的差异。有关 $V_{\text{I(dev)}}$ 的更多详细信息及其与平均温度系数的关系, 请参阅温度系数。
- (2) 动态阻抗被定义为: $|Z_{\text{KA}}| = \Delta V_{\text{KA}} / \Delta I_{\text{KA}}$ 。有关 $|Z_{\text{KA}}|$ 的更多详细信息及其与 V_{KA} 的关系, 请参阅动态阻抗。

6.7 电气特性, TL431Q、TL432Q

在推荐的工作条件下测得, $T_A = 25^\circ\text{C}$ (除非另有说明)

参数		测试电路	测试条件	最小值	典型值	最大值	单位
V_{ref}	基准电压	请参阅图 7-1	$V_{\text{KA}} = V_{\text{ref}}, I_{\text{KA}} = 10\text{mA}$	2440	2495	2550	mV
$V_{\text{I(dev)}}$	整个温度范围内的基准输入电压偏差 (1)	请参阅图 7-1	$V_{\text{KA}} = V_{\text{ref}}, I_{\text{KA}} = 10\text{mA}$		14	34	mV
$\Delta V_{\text{ref}} / \Delta V_{\text{KA}}$	基准电压变化与阴极电压变化之比	请参阅图 7-2	$I_{\text{KA}} = 10\text{mA}$	$\Delta V_{\text{KA}} = 10\text{V} - V_{\text{ref}}$	-1.4	-2.7	mV/V
				$\Delta V_{\text{KA}} = 36\text{V} - 10\text{V}$	-1	-2	mV/V
I_{ref}	基准输入电流	请参阅图 7-2	$I_{\text{KA}} = 10\text{mA}, R1 = 10\text{k}\Omega, R2 = \infty$		2	4	μA
$I_{\text{I(dev)}}$	整个温度范围内的基准输入电流偏差 (1)	请参阅图 7-2	$I_{\text{KA}} = 10\text{mA}, R1 = 10\text{k}\Omega, R2 = \infty$		0.8	2.5	μA
I_{min}	调节的最小阴极电流	请参阅图 7-1	$V_{\text{KA}} = V_{\text{ref}}$		0.4	1	mA
I_{off}	关闭状态阴极电流	请参阅图 7-3	$V_{\text{KA}} = 36\text{V}, V_{\text{ref}} = 0$		0.1	1	μA
$ Z_{\text{KA}} $	动态阻抗 (2)	请参阅图 7-1	$V_{\text{KA}} = V_{\text{ref}}, f \leq 1\text{kHz}, I_{\text{KA}} = 1\text{mA}$ 至 100mA		0.2	0.5	Ω

- (1) 偏差参数 $V_{\text{I(dev)}}$ 和 $I_{\text{I(dev)}}$ 是指在额定温度范围内获得的最大和最小值之间的差异。有关 $V_{\text{I(dev)}}$ 的更多详细信息及其与平均温度系数的关系, 请参阅[温度系数](#)。
- (2) 动态阻抗被定义为: $|Z_{\text{KA}}| = \Delta V_{\text{KA}} / \Delta I_{\text{KA}}$ 。有关 $|Z_{\text{KA}}|$ 的更多详细信息及其与 V_{KA} 的关系, 请参阅[动态阻抗](#)。

6.8 电气特性, TL431AC、TL432AC

在推荐的工作条件下测得, $T_A = 25^\circ\text{C}$ (除非另有说明)

参数		测试电路	测试条件	最小值	典型值	最大值	单位
V_{ref}	基准电压	请参阅图 7-1	$V_{\text{KA}} = V_{\text{ref}}, I_{\text{KA}} = 10\text{mA}$	2470	2495	2520	mV
$V_{\text{I(dev)}}$	整个温度范围内的基准输入电压偏差 (1)	请参阅图 7-1	$V_{\text{KA}} = V_{\text{ref}}, I_{\text{KA}} = 10\text{mA}$	SOT23-3 和 TL432 器件	6	16	mV
				所有其他器件	4	25	mV
$\Delta V_{\text{ref}} / \Delta V_{\text{KA}}$	基准电压变化与阴极电压变化之比	请参阅图 7-2	$I_{\text{KA}} = 10\text{mA}$	$\Delta V_{\text{KA}} = 10\text{V} - V_{\text{ref}}$	-1.4	-2.7	mV/V
				$\Delta V_{\text{KA}} = 36\text{V} - 10\text{V}$	-1	-2	mV/V
I_{ref}	基准输入电流	请参阅图 7-2	$I_{\text{KA}} = 10\text{mA}, R1 = 10\text{k}\Omega, R2 = \infty$	2	4		μA
$I_{\text{I(dev)}}$	整个温度范围内的基准输入电流偏差 (1)	请参阅图 7-2	$I_{\text{KA}} = 10\text{mA}, R1 = 10\text{k}\Omega, R2 = \infty$	0.8	1.2		μA
I_{min}	调节的最小阴极电流	请参阅图 7-1	$V_{\text{KA}} = V_{\text{ref}}$	0.4	0.6		mA
I_{off}	关闭状态阴极电流	请参阅图 7-3	$V_{\text{KA}} = 36\text{V}, V_{\text{ref}} = 0$	0.1	0.5		μA
$ Z_{\text{KA}} $	动态阻抗 (2)	请参阅图 7-1	$V_{\text{KA}} = V_{\text{ref}}, f \leq 1\text{kHz}, I_{\text{KA}} = 1\text{mA}$ 至 100mA	0.2	0.5		Ω

(1) 偏差参数 $V_{\text{I(dev)}}$ 和 $I_{\text{I(dev)}}$ 是指在额定温度范围内获得的最大和最小值之间的差异。有关 $V_{\text{I(dev)}}$ 的更多详细信息及其与平均温度系数的关系, 请参阅温度系数。

(2) 动态阻抗被定义为: $|Z_{\text{KA}}| = \Delta V_{\text{KA}} / \Delta I_{\text{KA}}$ 。有关 $|Z_{\text{KA}}|$ 的更多详细信息及其与 V_{KA} 的关系, 请参阅动态阻抗。

6.9 电气特性, TL431AI、TL432AI

在推荐的工作条件下测得, $T_A = 25^\circ\text{C}$ (除非另有说明)

参数		测试电路	测试条件	最小值	典型值	最大值	单位
V_{ref}	基准电压	请参阅图 7-1	$V_{\text{KA}} = V_{\text{ref}}, I_{\text{KA}} = 10\text{mA}$	2470	2495	2520	mV
$V_{\text{I(dev)}}$	整个温度范围内的基准输入电压偏差 (1)	请参阅图 7-1	$V_{\text{KA}} = V_{\text{ref}}, I_{\text{KA}} = 10\text{mA}$	SOT23-3 和 TL432 器件	14	34	mV
				所有其他器件	5	50	mV
$\Delta V_{\text{ref}} / \Delta V_{\text{KA}}$	基准电压变化与阴极电压变化之比	请参阅图 7-2	$I_{\text{KA}} = 10\text{mA}$	$\Delta V_{\text{KA}} = 10\text{V} - V_{\text{ref}}$	-1.4	-2.7	mV/V
				$\Delta V_{\text{KA}} = 36\text{V} - 10\text{V}$	-1	-2	mV/V
I_{ref}	基准输入电流	请参阅图 7-2	$I_{\text{KA}} = 10\text{mA}, R1 = 10\text{k}\Omega, R2 = \infty$		2	4	μA
$I_{\text{I(dev)}}$	整个温度范围内的基准输入电流偏差 (1)	请参阅图 7-2	$I_{\text{KA}} = 10\text{mA}, R1 = 10\text{k}\Omega, R2 = \infty$		0.8	2.5	μA
I_{min}	调节的最小阴极电流	请参阅图 7-1	$V_{\text{KA}} = V_{\text{ref}}$		0.4	0.7	mA
I_{off}	关闭状态阴极电流	请参阅图 7-3	$V_{\text{KA}} = 36\text{V}, V_{\text{ref}} = 0$		0.1	0.5	μA
$ Z_{\text{KA}} $	动态阻抗 (2)	请参阅图 7-1	$V_{\text{KA}} = V_{\text{ref}}, f \leq 1\text{kHz}, I_{\text{KA}} = 1\text{mA}$ 至 100mA		0.2	0.5	Ω

- (1) 偏差参数 $V_{\text{I(dev)}}$ 和 $I_{\text{I(dev)}}$ 是指在额定温度范围内获得的最大和最小值之间的差异。有关 $V_{\text{I(dev)}}$ 的更多详细信息及其与平均温度系数的关系, 请参阅温度系数。
- (2) 动态阻抗被定义为: $|Z_{\text{KA}}| = \Delta V_{\text{KA}} / \Delta I_{\text{KA}}$ 。有关 $|Z_{\text{KA}}|$ 的更多详细信息及其与 V_{KA} 的关系, 请参阅动态阻抗。

6.10 电气特性, TL431AQ、TL432AQ

在推荐的工作条件下测得, $T_A = 25^\circ\text{C}$ (除非另有说明)

参数		测试电路	测试条件	最小值	典型值	最大值	单位
V_{ref}	基准电压	请参阅图 7-1	$V_{\text{KA}} = V_{\text{ref}}, I_{\text{KA}} = 10\text{mA}$	2470	2495	2520	mV
$V_{\text{I(dev)}}$	整个温度范围内的基准输入电压偏差 (1)	请参阅图 7-1	$V_{\text{KA}} = V_{\text{ref}}, I_{\text{KA}} = 10\text{mA}$		14	34	mV
$\Delta V_{\text{ref}} / \Delta V_{\text{KA}}$	基准电压变化与阴极电压变化之比	请参阅图 7-2	$I_{\text{KA}} = 10\text{mA}$	$\Delta V_{\text{KA}} = 10\text{V} - V_{\text{ref}}$	-1.4	-2.7	mV/V
				$\Delta V_{\text{KA}} = 36\text{V} - 10\text{V}$	-1	-2	mV/V
I_{ref}	基准输入电流	请参阅图 7-2	$I_{\text{KA}} = 10\text{mA}, R_1 = 10\text{k}\Omega, R_2 = \infty$		2	4	μA
$I_{\text{I(dev)}}$	整个温度范围内的基准输入电流偏差 (1)	请参阅图 7-2	$I_{\text{KA}} = 10\text{mA}, R_1 = 10\text{k}\Omega, R_2 = \infty$		0.8	2.5	μA
I_{min}	调节的最小阴极电流	请参阅图 7-1	$V_{\text{KA}} = V_{\text{ref}}$		0.4	0.7	mA
I_{off}	关闭状态阴极电流	请参阅图 7-3	$V_{\text{KA}} = 36\text{V}, V_{\text{ref}} = 0$		0.1	0.5	μA
$ Z_{\text{KA}} $	动态阻抗 (2)	请参阅图 7-1	$V_{\text{KA}} = V_{\text{ref}}, f \leq 1\text{kHz}, I_{\text{KA}} = 1\text{mA}$ 至 100mA		0.2	0.5	Ω

- (1) 偏差参数 $V_{\text{I(dev)}}$ 和 $I_{\text{I(dev)}}$ 是指在额定温度范围内获得的最大和最小值之间的差异。有关 $V_{\text{I(dev)}}$ 的更多详细信息及其与平均温度系数的关系, 请参阅[温度系数](#)。
- (2) 动态阻抗被定义为: $|Z_{\text{KA}}| = \Delta V_{\text{KA}} / \Delta I_{\text{KA}}$ 。有关 $|Z_{\text{KA}}|$ 的更多详细信息及其与 V_{KA} 的关系, 请参阅[动态阻抗](#)。

6.11 电气特性, TL431BC、TL432BC

在推荐的工作条件下测得, $T_A = 25^\circ\text{C}$ (除非另有说明)

参数		测试电路	测试条件	最小值	典型值	最大值	单位
V_{ref}	基准电压	请参阅图 7-1	$V_{\text{KA}} = V_{\text{ref}}, I_{\text{KA}} = 10\text{mA}$	2483	2495	2507	mV
$V_{\text{I(dev)}}$	整个温度范围内的基准输入电压偏差 (1)	请参阅图 7-1	$V_{\text{KA}} = V_{\text{ref}}, I_{\text{KA}} = 10\text{mA}$		6	16	mV
$\Delta V_{\text{ref}} / \Delta V_{\text{KA}}$	基准电压变化与阴极电压变化之比	请参阅图 7-2	$I_{\text{KA}} = 10\text{mA}$	$\Delta V_{\text{KA}} = 10\text{V} - V_{\text{ref}}$	-1.4	-2.7	mV/V
				$\Delta V_{\text{KA}} = 36\text{V} - 10\text{V}$	-1	-2	mV/V
I_{ref}	基准输入电流	请参阅图 7-2	$I_{\text{KA}} = 10\text{mA}, R1 = 10\text{k}\Omega, R2 = \infty$		2	4	μA
$I_{\text{I(dev)}}$	整个温度范围内的基准输入电流偏差 (1)	请参阅图 7-2	$I_{\text{KA}} = 10\text{mA}, R1 = 10\text{k}\Omega, R2 = \infty$		0.8	1.2	μA
I_{min}	调节的最小阴极电流	请参阅图 7-1	$V_{\text{KA}} = V_{\text{ref}}$		0.4	0.6	mA
I_{off}	关闭状态阴极电流	请参阅图 7-3	$V_{\text{KA}} = 36\text{V}, V_{\text{ref}} = 0$		0.1	0.5	μA
$ Z_{\text{KA}} $	动态阻抗 (2)	请参阅图 7-1	$V_{\text{KA}} = V_{\text{ref}}, f \leq 1\text{kHz}, I_{\text{KA}} = 1\text{mA}$ 至 100mA		0.2	0.5	Ω

- (1) 偏差参数 $V_{\text{I(dev)}}$ 和 $I_{\text{I(dev)}}$ 是指在额定温度范围内获得的最大和最小值之间的差异。有关 $V_{\text{I(dev)}}$ 的更多详细信息及其与平均温度系数的关系, 请参阅[温度系数](#)。
- (2) 动态阻抗被定义为: $|Z_{\text{KA}}| = \Delta V_{\text{KA}} / \Delta I_{\text{KA}}$ 。有关 $|Z_{\text{KA}}|$ 的更多详细信息及其与 V_{KA} 的关系, 请参阅[动态阻抗](#)。

6.12 电气特性, TL431BI、TL432BI

在推荐的工作条件下测得, $T_A = 25^\circ\text{C}$ (除非另有说明)

参数		测试电路	测试条件	最小值	典型值	最大值	单位
V_{ref}	基准电压	请参阅图 7-1	$V_{\text{KA}} = V_{\text{ref}}, I_{\text{KA}} = 10\text{mA}$	2483	2495	2507	mV
$V_{\text{I(dev)}}$	整个温度范围内的基准输入电压偏差 (1)	请参阅图 7-1	$V_{\text{KA}} = V_{\text{ref}}, I_{\text{KA}} = 10\text{mA}$		14	34	mV
$\Delta V_{\text{ref}} / \Delta V_{\text{KA}}$	基准电压变化与阴极电压变化之比	请参阅图 7-2	$I_{\text{KA}} = 10\text{mA}$	$\Delta V_{\text{KA}} = 10\text{V} - V_{\text{ref}}$	-1.4	-2.7	mV/V
				$\Delta V_{\text{KA}} = 36\text{V} - 10\text{V}$	-1	-2	mV/V
I_{ref}	基准输入电流	请参阅图 7-2	$I_{\text{KA}} = 10\text{mA}, R1 = 10\text{k}\Omega, R2 = \infty$		2	4	μA
$I_{\text{I(dev)}}$	整个温度范围内的基准输入电流偏差 (1)	请参阅图 7-2	$I_{\text{KA}} = 10\text{mA}, R1 = 10\text{k}\Omega, R2 = \infty$		0.8	2.5	μA
I_{min}	调节的最小阴极电流	请参阅图 7-1	$V_{\text{KA}} = V_{\text{ref}}$		0.4	0.7	mA
I_{off}	关闭状态阴极电流	请参阅图 7-3	$V_{\text{KA}} = 36\text{V}, V_{\text{ref}} = 0$		0.1	0.5	μA
$ Z_{\text{KA}} $	动态阻抗 (2)	请参阅图 7-1	$V_{\text{KA}} = V_{\text{ref}}, f \leq 1\text{kHz}, I_{\text{KA}} = 1\text{mA}$ 至 100mA		0.2	0.5	Ω

- (1) 偏差参数 $V_{\text{I(dev)}}$ 和 $I_{\text{I(dev)}}$ 是指在额定温度范围内获得的最大和最小值之间的差异。有关 $V_{\text{I(dev)}}$ 的更多详细信息及其与平均温度系数的关系, 请参阅[温度系数](#)。
- (2) 动态阻抗被定义为: $|Z_{\text{KA}}| = \Delta V_{\text{KA}} / \Delta I_{\text{KA}}$ 。有关 $|Z_{\text{KA}}|$ 的更多详细信息及其与 V_{KA} 的关系, 请参阅[动态阻抗](#)。

6.13 电气特性, TL431BQ、TL432BQ

在推荐的工作条件下测得, $T_A = 25^\circ\text{C}$ (除非另有说明)

参数		测试电路	测试条件	最小值	典型值	最大值	单位
V_{ref}	基准电压	请参阅图 7-1	$V_{\text{KA}} = V_{\text{ref}}, I_{\text{KA}} = 10\text{mA}$	2483	2495	2507	mV
$V_{\text{I(dev)}}$	整个温度范围内的基准输入电压偏差 (1)	请参阅图 7-1	$V_{\text{KA}} = V_{\text{ref}}, I_{\text{KA}} = 10\text{mA}$		14	34	mV
$\Delta V_{\text{ref}} / \Delta V_{\text{KA}}$	基准电压变化与阴极电压变化之比	请参阅图 7-2	$I_{\text{KA}} = 10\text{mA}$	$\Delta V_{\text{KA}} = 10\text{V} - V_{\text{ref}}$	-1.4	-2.7	mV/V
				$\Delta V_{\text{KA}} = 36\text{V} - 10\text{V}$	-1	-2	mV/V
I_{ref}	基准输入电流	请参阅图 7-2	$I_{\text{KA}} = 10\text{mA}, R1 = 10\text{k}\Omega, R2 = \infty$		2	4	μA
$I_{\text{I(dev)}}$	整个温度范围内的基准输入电流偏差 (1)	请参阅图 7-2	$I_{\text{KA}} = 10\text{mA}, R1 = 10\text{k}\Omega, R2 = \infty$		0.8	2.5	μA
I_{min}	调节的最小阴极电流	请参阅图 7-1	$V_{\text{KA}} = V_{\text{ref}}$		0.4	0.7	mA
I_{off}	关闭状态阴极电流	请参阅图 7-3	$V_{\text{KA}} = 36\text{V}, V_{\text{ref}} = 0$		0.1	0.5	μA
$ Z_{\text{KA}} $	动态阻抗 (2)	请参阅图 7-1	$V_{\text{KA}} = V_{\text{ref}}, f \leq 1\text{kHz}, I_{\text{KA}} = 1\text{mA}$ 至 100mA		0.2	0.5	Ω

- (1) 偏差参数 $V_{\text{I(dev)}}$ 和 $I_{\text{I(dev)}}$ 是指在额定温度范围内获得的最大和最小值之间的差异。有关 $V_{\text{I(dev)}}$ 的更多详细信息及其与平均温度系数的关系, 请参阅[温度系数](#)。
- (2) 动态阻抗被定义为: $|Z_{\text{KA}}| = \Delta V_{\text{KA}} / \Delta I_{\text{KA}}$ 。有关 $|Z_{\text{KA}}|$ 的更多详细信息及其与 V_{KA} 的关系, 请参阅[动态阻抗](#)。

6.14 典型特性

高温和低温下的数据仅适用于各种器件在自然通风条件下的推荐工作温度范围内。

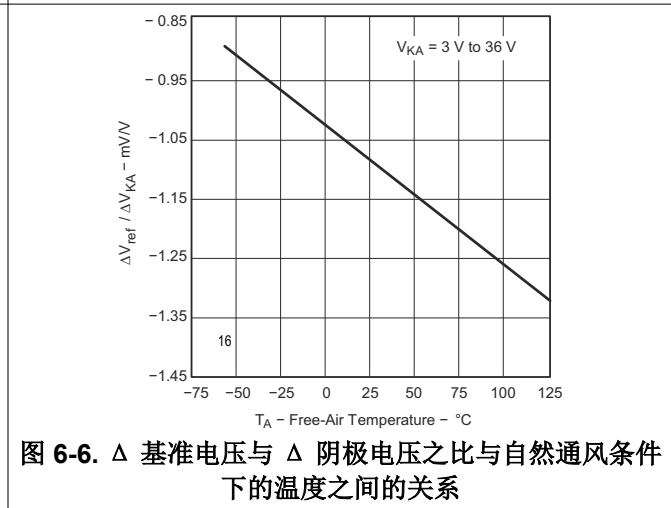
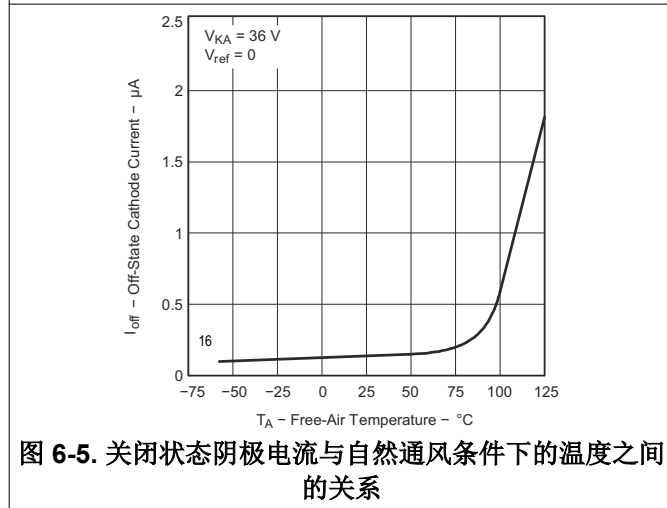
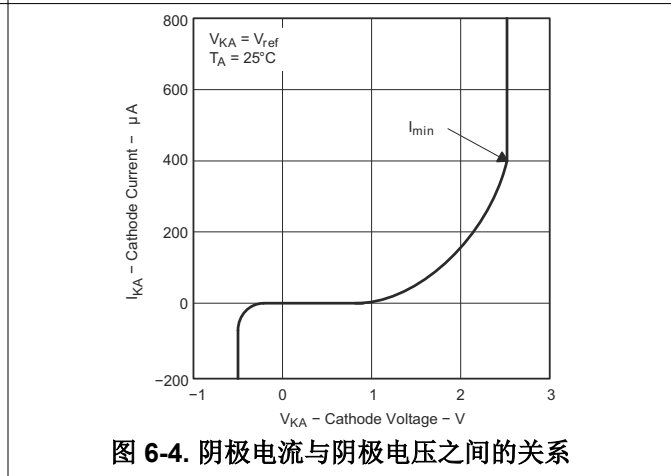
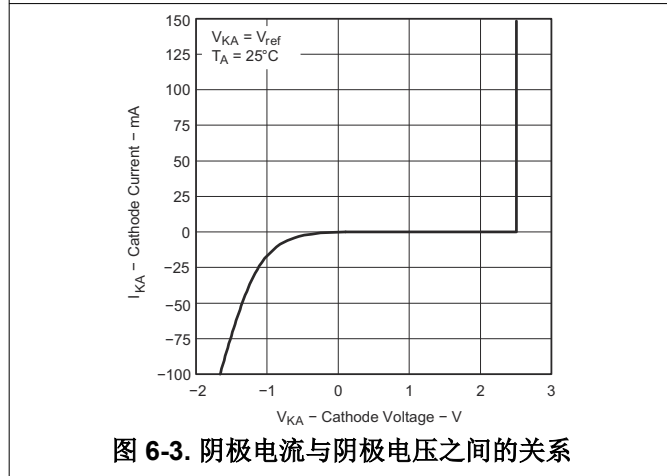
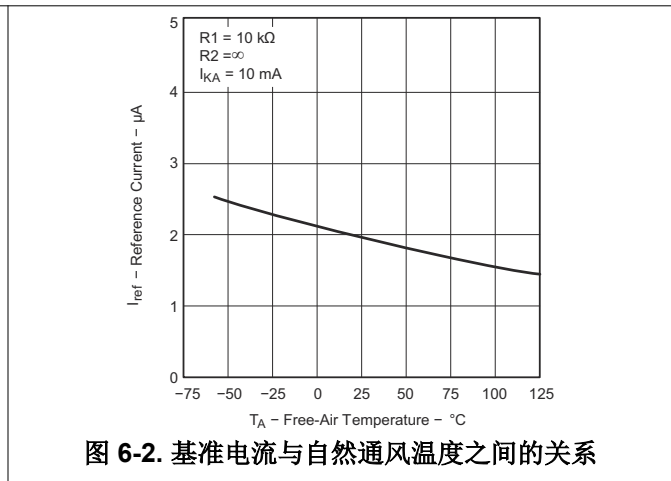
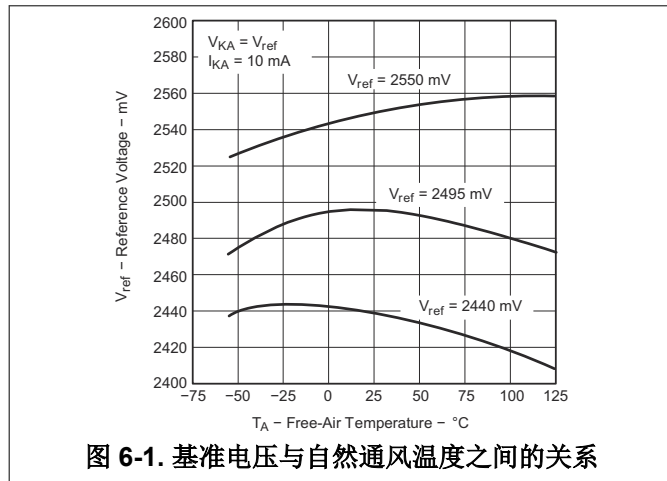



图 6-7. 等效输入噪声电压与频率间的关系



图 6-8. 10S 周期内的等效输入噪声电压

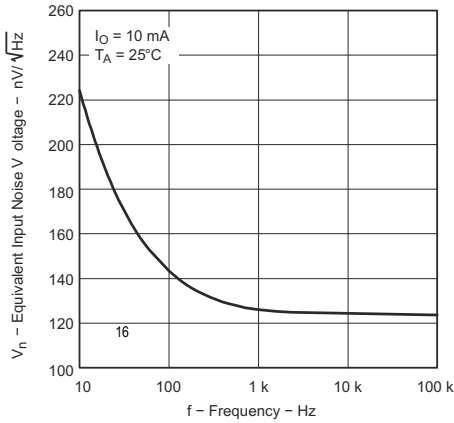

图 6-9. 10S 周期内等效输入噪声电压的测试电路

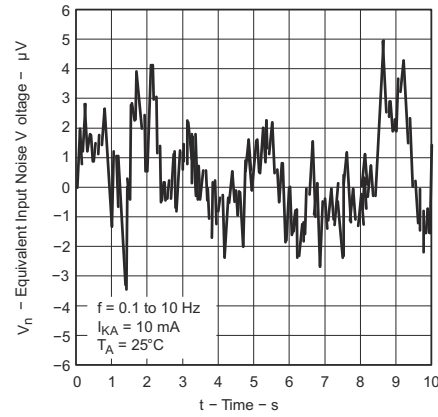

图 6-10. 小信号电压放大与频率之间的关系

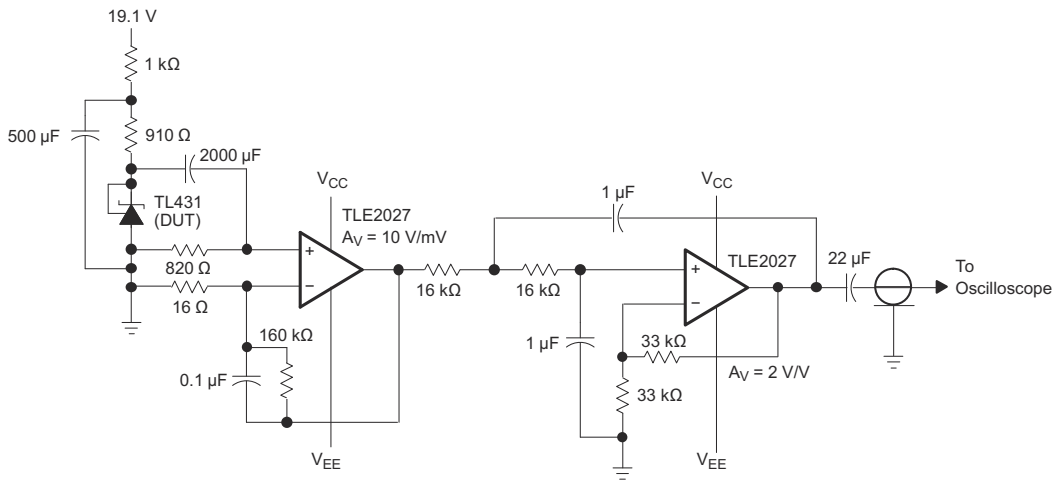

图 6-11. 电压放大测试电路

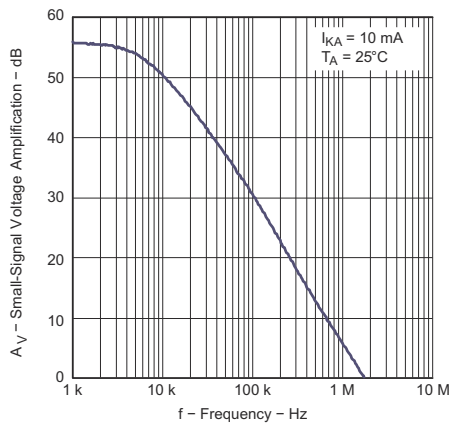

图 6-12. 基准阻抗与频率之间的关系

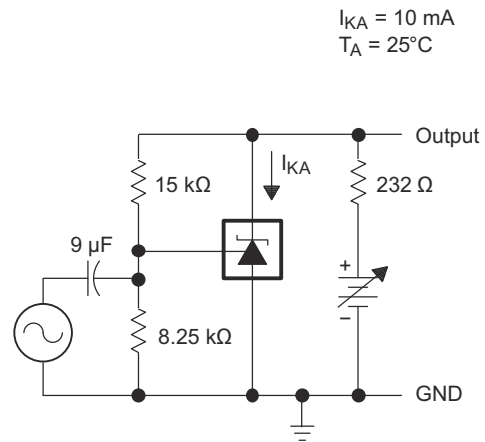

图 6-13. 基准阻抗测试电路

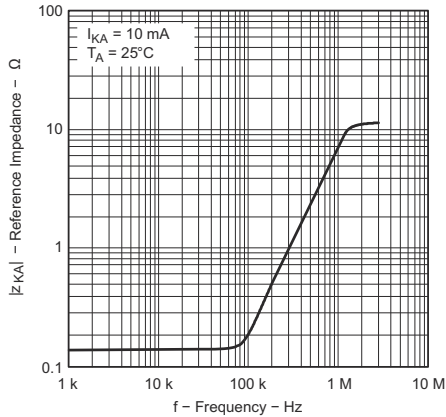

图 6-14. 脉冲响应

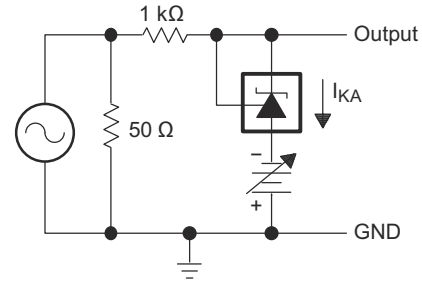

图 6-15. 脉冲响应测试电路

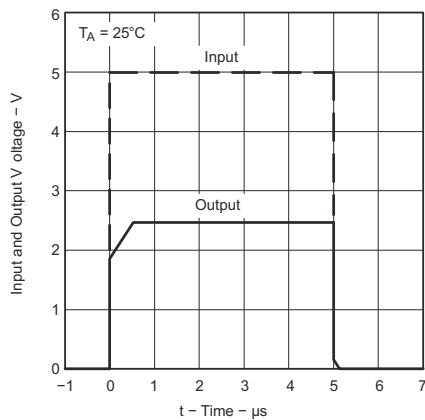

曲线下的区域表示可能导致器件振荡的条件。针对曲线 B、C 和 D，对 R2 和 V+ 进行了调整，以建立初始 VKA 和 IKA 条件，且 CL = 0。然后，对 VBATT 和 CL 进行了调整，以确定稳定范围。

图 6-16. 所有 TL431 和 TL431A 器件的稳定性边界条件 (SOT23-3、SC-70 和 Q 级温度器件除外)

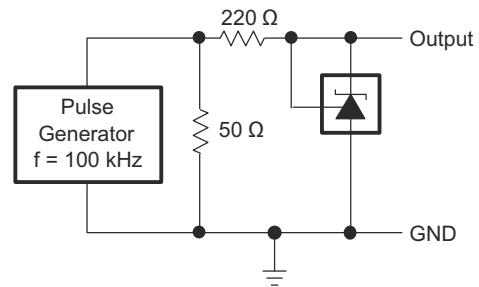
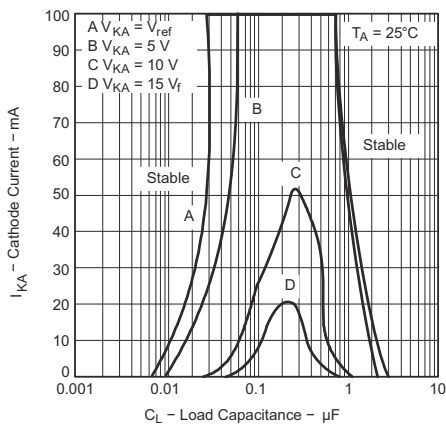

图 6-17. 稳定性边界条件测试电路



曲线下的区域表示可能导致器件振荡的条件。针对曲线 B、C 和 D，对 R2 和 V+ 进行了调整，以建立初始 V_{KA} 和 I_{KA} 条件，且 $C_L = 0$ 。然后，对 V_{BATT} 和 C_L 进行了调整，以确定稳定范围。

图 6-18. 所有 TL431B、TL432、SOT-23、SC-70 和 Q 级温度器件的稳定性边界条件

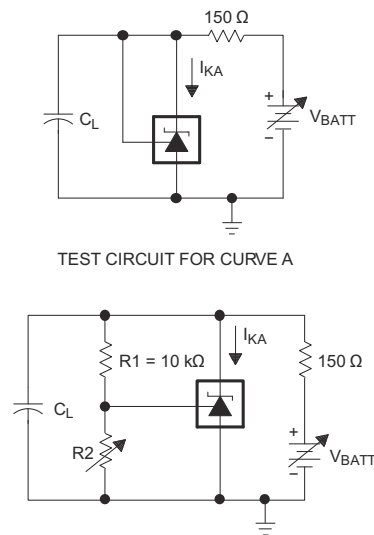
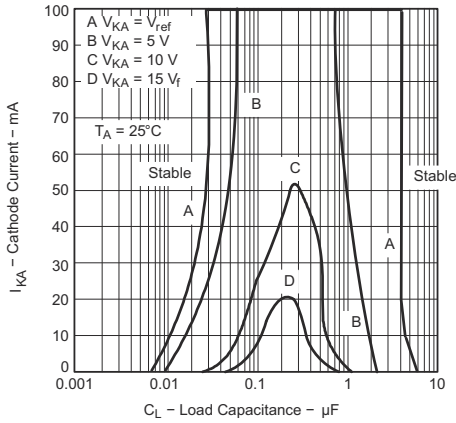
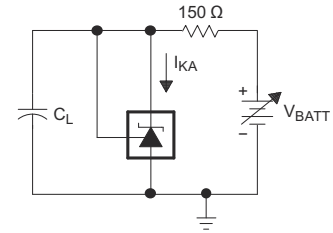

TEST CIRCUIT FOR CURVE A

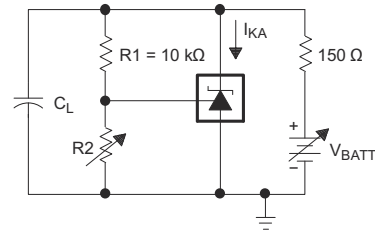

TEST CIRCUIT FOR CURVES B, C, AND D

图 6-19. 稳定性边界条件测试电路

7 参数测量信息



图 7-1. 针对 $V_{KA} = V_{ref}$ 的测试电路



图 7-2. 针对 $V_{KA} > V_{ref}$ 的测试电路

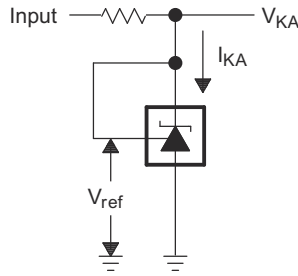

图 7-3. 针对 I_{off} 的测试电路

7.1 温度系数

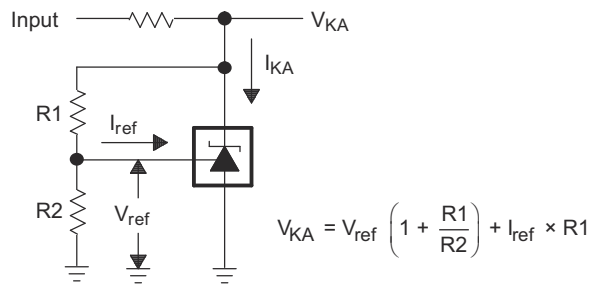
基准电压 V_{ref} 在整个温度范围内的偏差叫做 $V_{I(dev)}$ 。参数 $V_{I(dev)}$ 可用于找到器件的温度系数。基准输入电压的平均全范围温度系数 α_{Vref} 定义为：

$$\left| \alpha_{Vref} \right| \left(\frac{ppm}{^{\circ}C} \right) = \frac{\left(\frac{V_{I(dev)}}{V_{ref \text{ at } 25^{\circ}C}} \right) \times 10^6}{\Delta T_A}$$

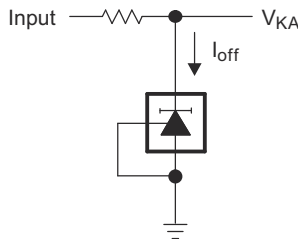
where:

ΔT_A is the rated operating temperature range of the device.

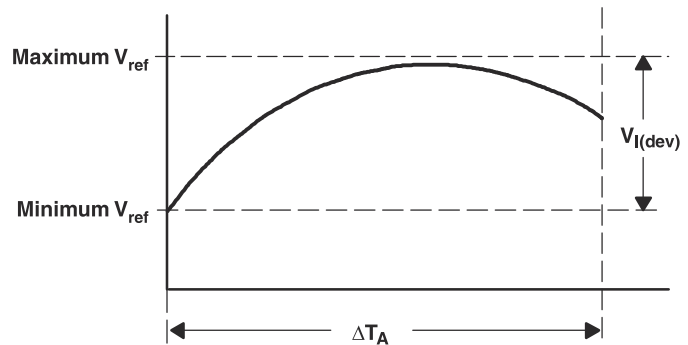

α_{Vref} 可能是正数，也可能是负数，具体取决于较低温度条件下出现的是最小 V_{ref} 还是最大 V_{ref} 。全范围温度系数是一个平均值，因此在额定工作温度范围的任何分段内都可能得到大于或小于该平均值的值。有关温度系数的更多详细信息，请参阅《电压基准选择基础知识》白皮书。

7.2 动态阻抗

动态阻抗定义为 $|Z_{KA}| = \frac{\Delta V_{KA}}{\Delta I_{KA}}$ 。当器件在配备两个外部电阻器的情况下运行时（参见图 6-13），电路的总动态阻抗为 $|z'| = \frac{\Delta V}{\Delta I}$ ，约等于 $|Z_{KA}| \left(1 + \frac{R1}{R2}\right)$ 。

该器件的 V_{KA} 可能会受该动态阻抗的影响。电气特性中指定了针对 V_{KA} 的器件测试电流 I_{test} 。任何对 I_{test} 的偏离都可能会造成输出 V_{KA} 上的偏差。图 7-4 显示了动态阻抗对 V_{KA} 的影响。



图 7-4. 动态阻抗

8 详细说明

8.1 概述

此标准器件已经证明可广泛应用于从电源到信号路径的各种应用。这是由于它的关键部件包含精确的电压基准和运算放大器，这是非常基本的模拟构建块。TL43xx 与其关键元器件搭配使用，可用作单个电压基准、误差放大器、电压钳位或具有集成基准的比较器。

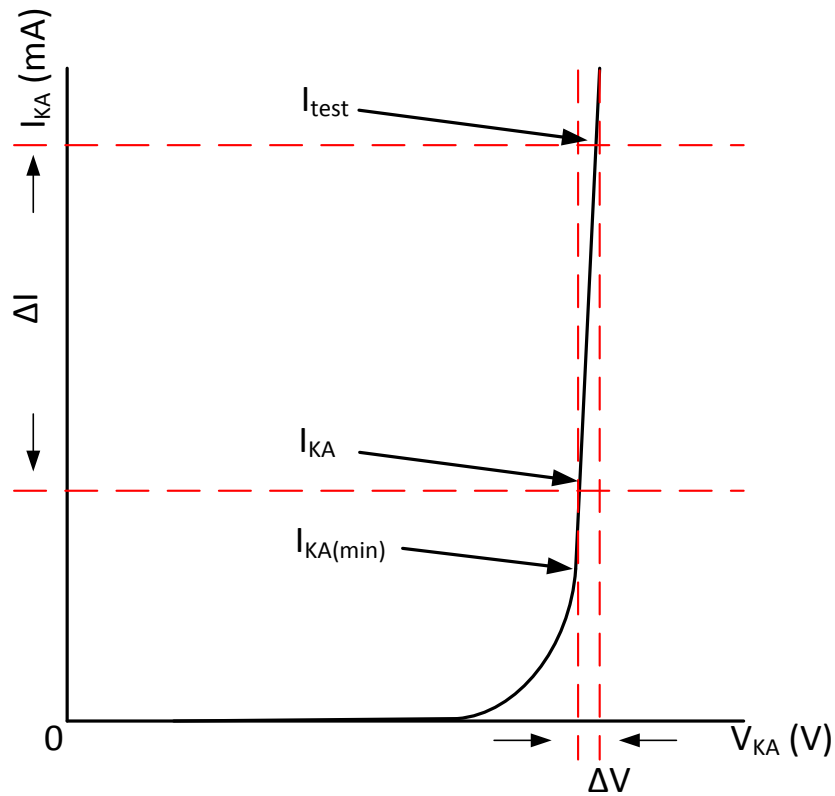
TL43xx 能够运行并调整到 2.5V 至 36V 的阴极电压，这使得该器件成为了工业、汽车、电信和计算领域中各种终端设备的最佳选择。若要将该器件用作并联稳压器或误差放大器，必须为阴极引脚提供 $>1\text{mA}$ ($I_{\text{min(max)}}$) 的电流。在这种情况下，可以从阴极引脚和基准引脚施加反馈，以创建内部基准电压的副本。

您可以购买初始容差为 0.5%、1% 和 2% (在 25°C 条件下) 的各种基准电压选项。这些基准选项以在 TL431 或 TL432 之后跟 B (0.5%)、A (1.0%) 和空白 (2.0%) 的形式表示。TL431 和 TL432 的功能相同，但具有不同的引脚排列选项。

TL43xxC 器件运行温度范围为 0°C 至 70°C，TL43xxI 器件运行温度范围为 -40°C 至 85°C，TL43xxQ 器件运行温度范围为 -40°C 至 125°C。

8.2 功能方框图



图 8-1. 等效原理图



图 8-2. 详细的原理图

8.3 特性说明

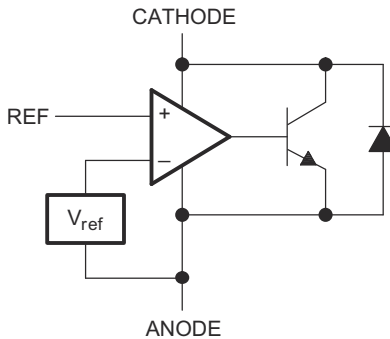
TL43xx 由内部基准和根据基准引脚和虚拟内部引脚之间的差异输出灌电流的放大器组成。该灌电流由内部达林顿对产生，如上文中的原理图（图 8-2）所示。使用达林顿对是为了使该器件能够吸收最高 100mA 的电流。

在具有足够电压余量 ($\geq 2.5V$) 和阴极电流 (I_{KA}) 的情况下运行时，TL431 会将基准引脚电压强制为 2.5V。不过，基准引脚不能悬空，因为基准引脚需要 $I_{REF} \geq 4\mu A$ （请参阅 [电气特性, TL431C、TL432C](#)）。这是因为基准引脚会被驱动到 npn 中，后者要有基极电流才能正常工作。

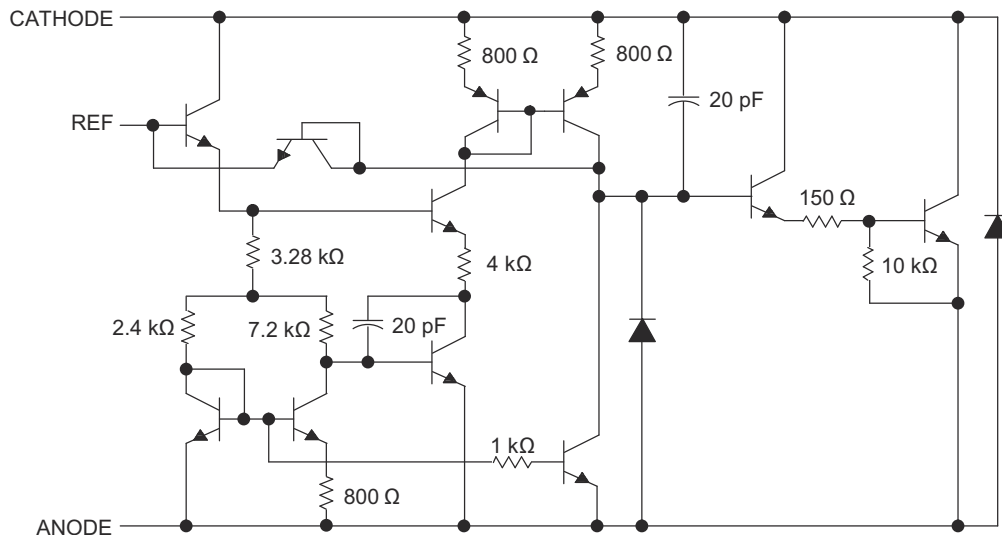
当从阴极引脚和基准引脚施加反馈时，TL43xx 将作为齐纳二极管，根据向阴极提供的电流将输出电压调节至恒定电压。这是由于内部放大器和基准进入了适当的运行区域。在开环、伺服或误差放大实现中，为了使该器件保持在合适的线性区域，必须向其施加与在反馈情况下所需电流的大小相同的电流，从而使 TL43xx 具有足够的增益。

与许多线性稳压器不同的是，TL43xx 通过内部补偿来达到稳定，无需在阴极和阳极之间使用输出电容器。但是，如果需要为该器件使用输出电容器，图 6-18 可作为一个指导，来帮助您选择用于保持稳定性的合适电容器。

8.4 器件功能模式

8.4.1 开环 (比较器)

当 TL43xx 的阴极/输出电压或电流未以任何形式馈送回基准/输入引脚时，该器件便是处于开环状态。在向该器件施加合适的阴极电流 (I_{KA}) 后，TL43xx 将会具有图 9-2 中所示的特性。这种配置具有如此高的增益，因此 TL43xx 通常用作比较器。TL43xx 具有集成的内部基准，因此，当用户想要监控单个信号的某个电平时，该器件便成为了他们的理想选择。

8.4.2 闭环

当 TL43xx 的阴极/输出电压或电流以任何形式馈送回基准/输入引脚时，该器件便是处于闭环状态。涉及 TL43xx 的多数应用都是采用这种模式，从而实现调节至固定电压或电流的目的。反馈使得该器件能够作为误差放大器，计算输出电压的一部分，并对其进行调整以保持期望的调节。实现该目标的途径是：将输出电压以某种方式关联至基准引脚，从而使其等于内部基准电压（这可以通过电阻反馈或直接反馈来实现）。

9 应用和实现

备注

以下应用部分中的信息不属于 TI 元件规范，TI 不担保其准确性和完整性。TI 的客户应负责确定各元件是否适用于其应用。客户应验证并测试其设计实现，以确保系统功能正常。

9.1 应用信息

该器件具有很多应用和设置，因此许多情况都无法在本数据表中进行详述。链接的应用手册可帮助设计人员在使用此器件时制定理想的选择。

应用手册 [了解 TL431/TL432 数据表中的稳定性边界条件图 \(SLVA482\)](#) 可帮助用户更深入地了解此类器件的稳定性特征和选择合适的负载电容器。应用手册 [在可调并联稳压器上设置并联电压 \(SLVA445\)](#) 可协助设计人员设置并联电压，以达到该设备的理想精度。

9.2 典型应用

9.2.1 具有集成基准的比较器



图 9-1. 比较器应用原理图

9.2.1.1 设计要求

本设计示例使用 [表 9-1](#) 中所列的参数作为输入参数。

表 9-1. 设计参数

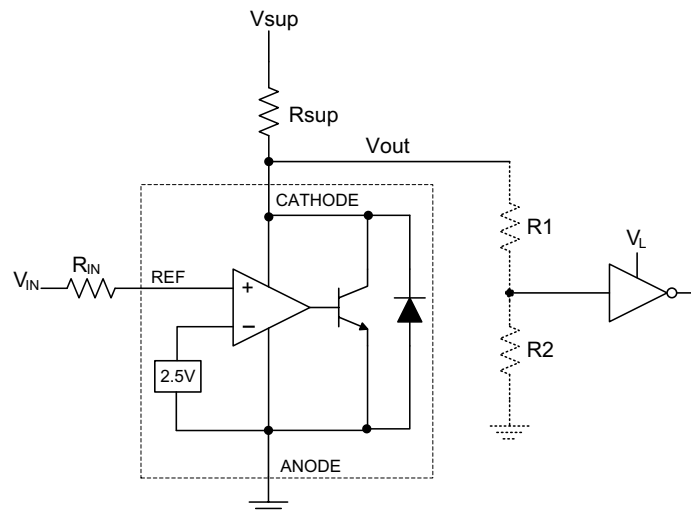
设计参数	示例值
输入电压范围	0V 至 5V
输入电阻	10k Ω
电源电压	24V
阴极电流 (I _K)	5mA
输出电压电平	~2V - V _{SUP}
逻辑输入阈值 V _{IH} /V _{IL}	V _L

9.2.1.2 详细设计过程

在将 TL431 用作具有基准电压的比较器时，需要确定以下参数：

- 输入电压范围
- 基准电压精度
- 输出/逻辑输入高低电平阈值
- 电流源电阻

9.2.1.2.1 基本操作

在 [图 9-1](#) 所示的配置中，TL431 将作为比较器，将 V_{REF} 引脚电压与内部虚拟基准电压进行比较。在获得合适的阴极电流 (I_K) 时，TL43xx 将具有足够的开环增益来提供快速响应。[图 9-2](#) 展示了这种情况，其中 R_{SUP}=10k Ω (I_{KA}=500 μ A) 的情况要比 R_{SUP}=1k Ω (I_{KA}=5mA) 时的响应速度慢得多。在 I_{min} 附近及以下运行可能会导致增益较低，从而导致响应速度缓慢。

9.2.1.2.1.1 过驱

未为基准引脚提供足够的过驱动电压也可能导致响应较慢或不准确。该电压高于内部虚拟基准电压。内部虚拟基准电压将在 2.5V \pm 0.5%、1.0% 或 1.5% (具体取决于所使用的版本) 范围内。所提供的过驱动电压越高，TL431 的响应速度就会越快。

对于 TL431 用作比较器的应用，最好是将跳闸点设置为高于正预期误差 (对于 A 版本来说是 +1.0%) 为了实现快速响应，将跳闸点设置为高于内部 V_{REF} 的 10% 就足够了。

为了实现从 V_{in} 到基准引脚的最低压降或电压差，建议使用阻值低于 10k Ω 的输入电阻器来提供 I_{ref}。

9.2.1.2.2 输出电压和逻辑输入电平

为了使 TL431 能够正常地用作比较器，逻辑输出必须可供接收逻辑器件读取。这是通过了解输入高低电平阈值电压电平（通常表示为 V_{IH} 和 V_{IL} ）来实现的。

如图 9-2 中所示，TL431 在开环/比较器模式下的输出低电平电压大约为 2V，这通常已经足够支持 5V 的供应逻辑。但却无法支持 3.3V 和 1.8V 的供应逻辑。为了适应这种情况，可以在输出端连接一个电阻分压器，以将输出电压衰减到方便低电压逻辑接收器件读取的电压。

TL431 的输出高电压等于 V_{SUP} ，因为 TL431 处于集电极开路状态。如果 V_{SUP} 远高于接收逻辑的最大输入电压容差，则必须对输出进行衰减，以确保输出逻辑的稳定性。

当在输出端上使用电阻分压器时，务必要使电阻分压器（图 9-1 中的 R1 和 R2）之和远高于 R_{SUP} ，以免影响 TL431 在关闭时将电压拉近至 V_{SUP} 的能力。

9.2.1.2.2.1 输入电阻

在此应用中，TL431 需要具有输入电阻，以确保此器件所提供的所需基准拉电流 (I_{REF}) 在开启期间保持在合适的运行区域内。基准引脚上的实际电压为 $V_{REF}=V_{IN}-I_{REF}*R_{IN}$ 。 I_{REF} 可能会高达 $4\mu A$ ，因此建议使用足够小的电阻，这将能够减小 I_{REF} 通过 V_{IN} 造成的误差。

9.2.1.3 应用曲线



图 9-2. 各种阴极电流情况下的输出响应

9.2.2 并联稳压器/基准

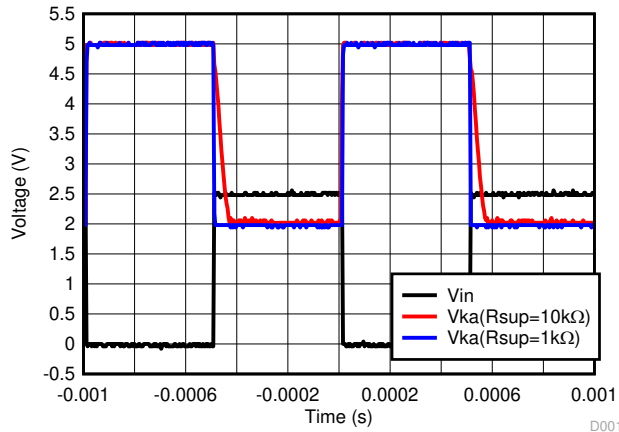

图 9-3. 并联稳压器原理图

9.2.2.1 设计要求

本设计示例使用表 9-1 中所列的参数作为输入参数。

表 9-2. 设计参数

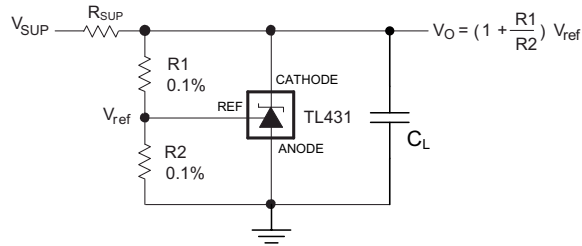
设计参数	示例值
基准初始精度	1.0%
电源电压	24V
阴极电流 (I _k)	5mA
输出电压电平	2.5V - 36V
负载电容	10 μF
反馈电阻器值和精度 (R1 和 R2)	10k Ω

9.2.2.2 详细设计过程

在将 TL431 用作并联稳压器时，需要确定以下参数：

- 输入电压范围
- 温度范围
- 总精度
- 阴极电流
- 基准初始精度
- 输出电容

9.2.2.2.1 可编程输出/阴极电压

为了将阴极电压编程至调节电压，必须对阴极和阳极引脚之间的电阻桥进行分流，即将中点处连接至基准引脚。您可以在图 9-3 中看到该电路，其中电阻桥由 R1 和 R2 组成。您可以使用图 9-3 中所示的公式计算出并联稳压器配置中的阴极/输出电压近似值。您还可以通过考虑阴极电流，更精确地确定阴极电压：

$$V_o = (1 + R1/R2) * V_{REF} - I_{REF} * R1$$

为了使该公式有效，TL43xx 必须完全偏置，以便它具有足够的开环增益来减小任何增益误差。这可以通过满足节 6.5 中指示的 I_{min} 规格来实现。

9.2.2.2.2 总精度

当对高于单位增益 ($V_{KA}=V_{REF}$) 的输出进行编程时，除 V_{REF} 之外，TL43xx 还容易受其他误差的影响，这些误差可能会影响整体精度。这些误差包括：

- R1 和 R2 的精度
- $V_{I(dev)}$ - 基准电压随温度的变化
- $\Delta V_{REF} / \Delta V_{KA}$ - 基准电压变化与阴极电压变化之比
- $|z_{KA}|$ - 动态阻抗，通过阴极电流导致阴极电压的变化

将所有这些变量考虑在内，便可确定最坏情况下的阴极电压。应用手册 [在可调并联稳压器上设置并联电压 \(SLVA445\)](#) 可协助设计人员设置并联电压，以达到该设备的理想精度。

9.2.2.2.3 稳定性

虽然 TL43xx 在没有容性负载的情况下是稳定的，但是接收并联稳压器输出电压的器件可能会产生 TL43xx 稳定区域 (如图 6-16 和图 6-18 中所示) 内的容性负载。此外，设计人员可以使用容性负载来改进瞬态响应或进行电源去耦。在阴极和阳极之间使用额外电容时，请参阅图 6-16 和图 6-18。此外，应用手册 [了解 TL431/TL432 数据表中的稳定性边界条件图 \(SLVA482\)](#) 可帮助用户更深入地了解此类器件的稳定性特征和选择合适的负载电容器。

9.2.2.2.4 启动时间

如图 9-4 中所示，TL43xx 具有高达约 2V 的快速响应，然后会缓慢充电至其编程值。这得益于 TL43xx 为了达到稳定性标准而配备的补偿电容 (如图 6-18 所示)。尽管存在二次延迟，TL43xx 的快速响应仍然能够满足许多钳位应用的需要。

9.2.2.3 应用曲线



图 9-4. TL43xx 启动响应

9.3 系统示例

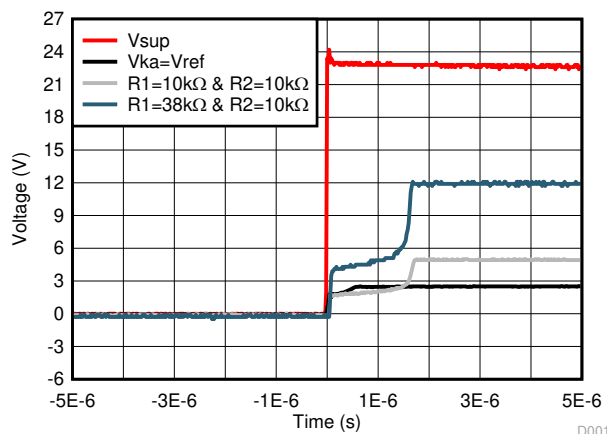
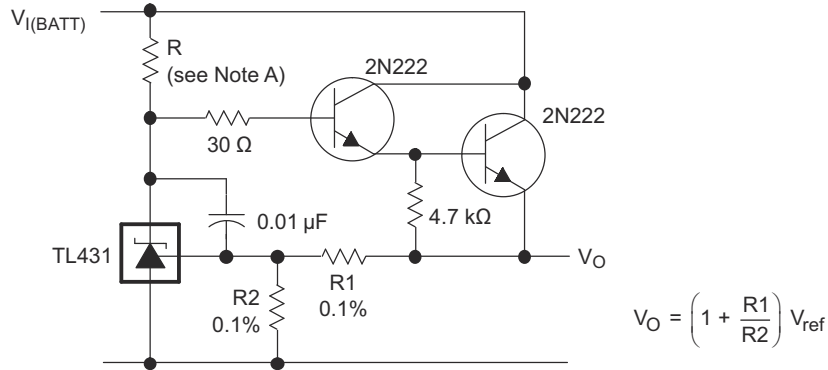

A. R 应在最低 $V_{(BATT)}$ 情况下向 TL431 提供 $\geq 1\text{mA}$ 的阴极电流。

图 9-5. 精密大电流串联稳压器



图 9-6. 三端固定稳压器的输出控制



图 9-7. 大电流并联稳压器

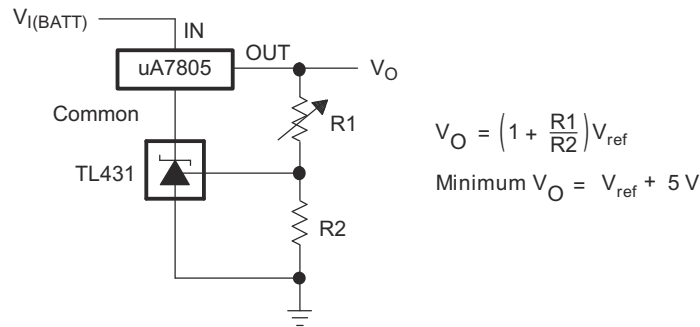

A. 请参阅图 6-16 和图 6-18 中的稳定性边界条件，以确定 C 的允许值。

图 9-8. Crowbar 电路

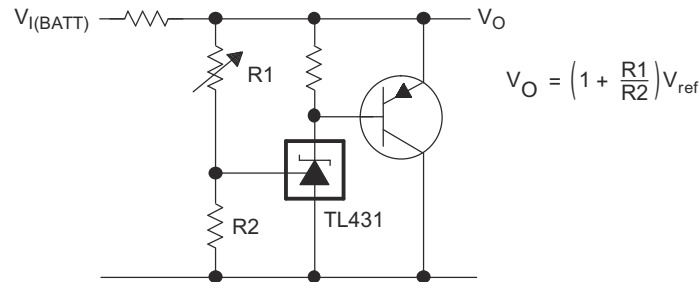
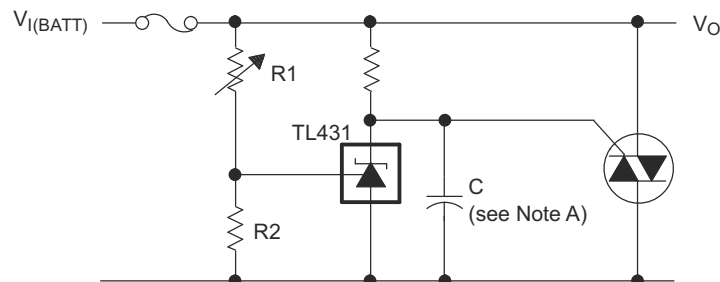

图 9-9. 精密 5V、1.5A 稳压器



A. R_b 应向 TL431 提供 $\geq 1\text{mA}$ 的阴极电流。

图 9-10. 高效 5V 精密稳压器

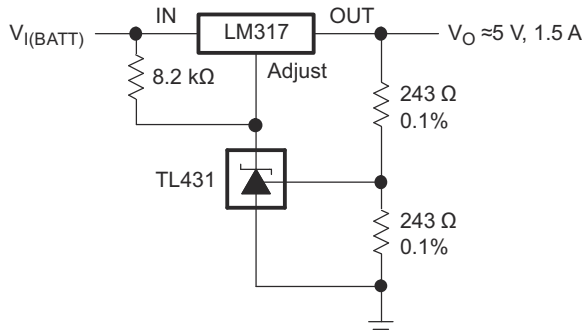
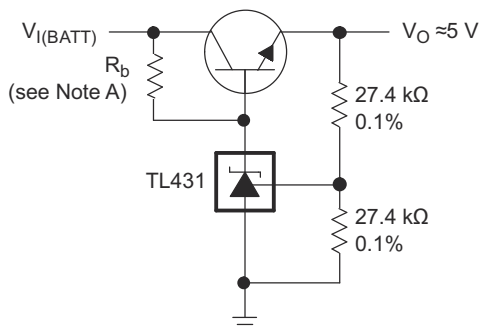

图 9-11. 具有基准电压的 PWM 转换器



A. 选择 R3 和 R4，以在可用的 $V_{I(BATT)}$ 条件下提供所需的 LED 强度并为 TL431 提供 $\geq 1\text{mA}$ 的阴极电流。

图 9-12. 电压监控器

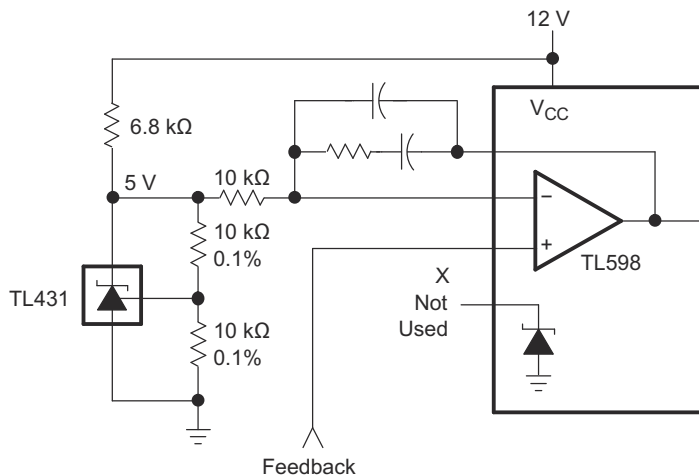
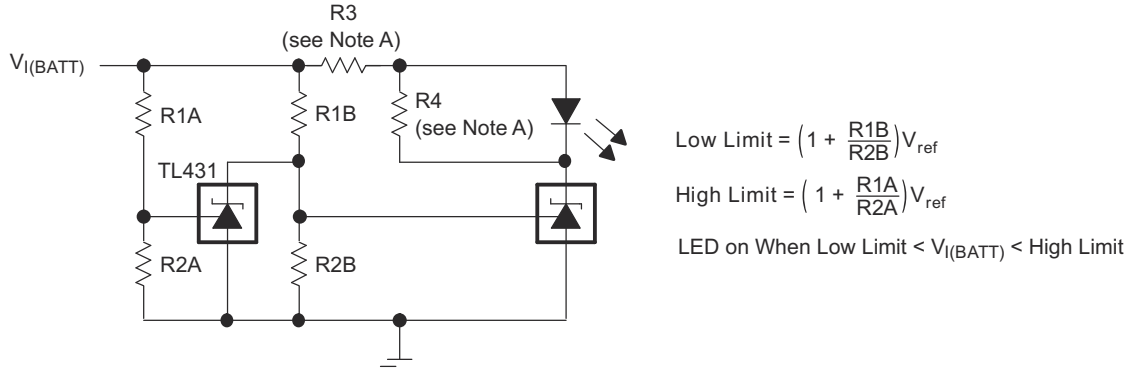

图 9-13. 延迟计时器



图 9-14. 精密限流器

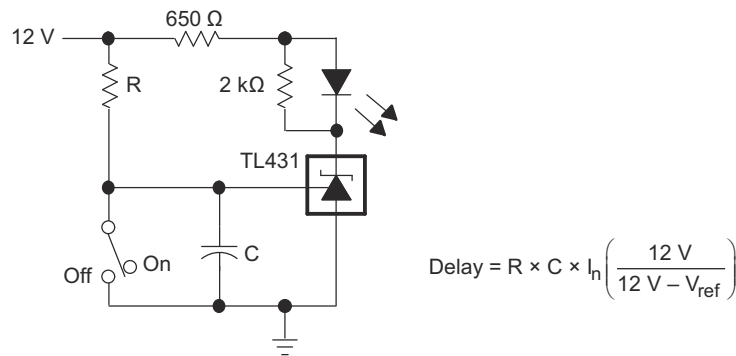

图 9-15. 精密恒定电流吸收器

9.4 电源相关建议

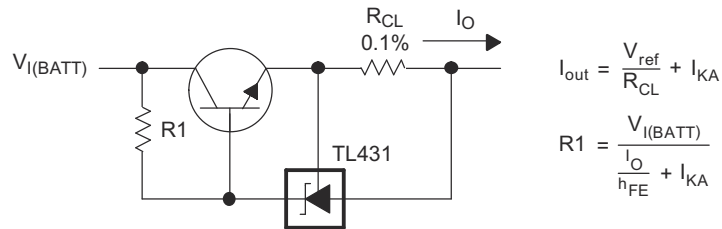
当使用 TL43xx 作为线性稳压器来为负载供电时，设计人员通常会在输出/阴极引脚上使用旁路电容。这样做时，请确保电容符合图 6-16 和图 6-18 中所示的稳定性标准。

为了避免超出最大阴极电流，请确保电源电压符合电流要求的限制。另外，请务必限制流入基准引脚的电流，以免其超过绝对最大额定值。

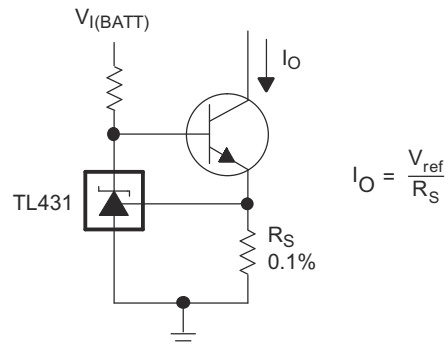
对于分流高电流的应用，请注意阴极和阳极迹线的长度，从而调整迹线宽度以获得适当的电流密度。

9.5 布局

9.5.1 布局指南

旁路电容器应尽可能靠近该部件。载流迹线需要具有适合其所承载的电流量的宽度；对于 TL43xx，这些电流很低。

9.5.2 布局示例



图 9-16. DBZ 布局示例

10 器件和文档支持

10.1 器件命名规则

TI 通过分配前缀和后缀来区分 TL43x 系列的所有组合。环保计划标识符是曾用于区分无铅和绿色环保器件的旧标识符。更多详细信息和可以订购的组合请参阅[机械、封装和可订购信息](#)中的“封装选项附录”。

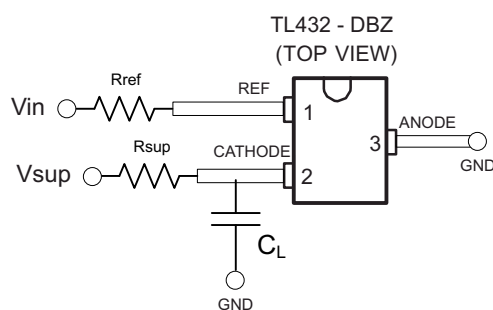
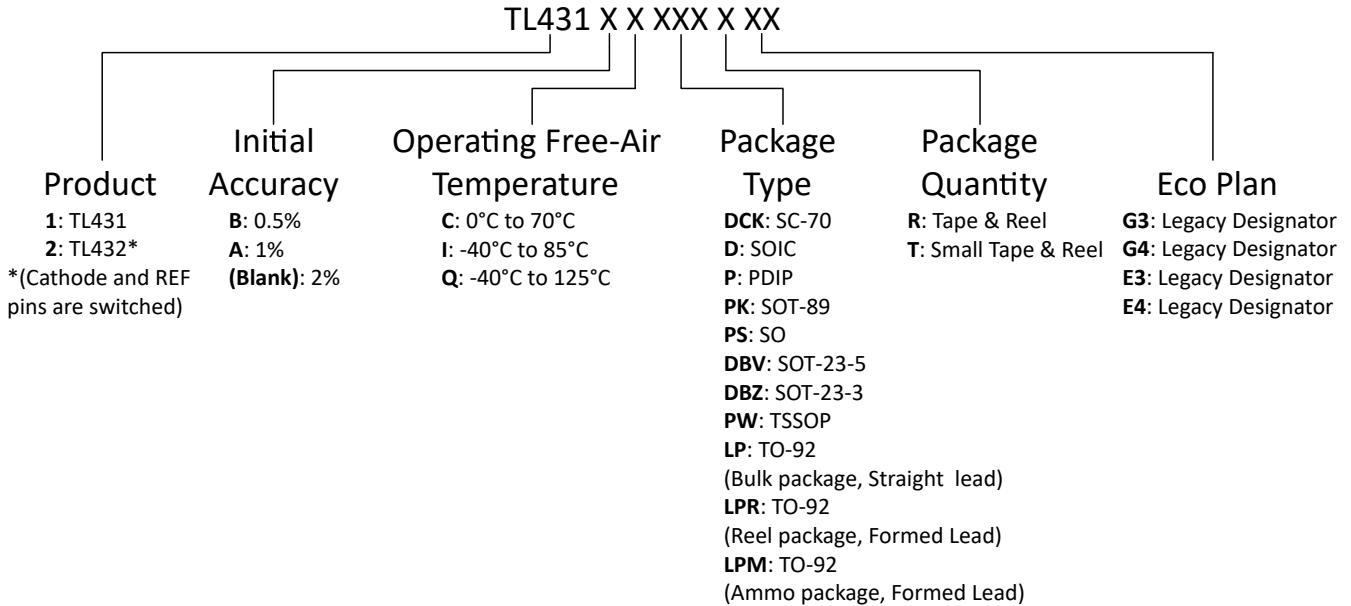

10.2 相关链接

下表列出了快速访问链接。类别包括技术文档、支持和社区资源、工具和软件，以及申请样片或购买产品的快速链接。

表 10-1. 相关链接

器件	产品文件夹	样片与购买	技术文档	工具和软件	支持和社区
TL431	点击此处	点击此处	点击此处	点击此处	点击此处
TL432	点击此处	点击此处	点击此处	点击此处	点击此处

10.3 接收文档更新通知

要接收文档更新通知，请导航至 ti.com 上的器件产品文件夹。点击 [通知](#) 进行注册，即可每周接收产品信息更改摘要。有关更改的详细信息，请查看任何已修订文档中包含的修订历史记录。

10.4 支持资源

TI E2E™ 中文支持论坛 是工程师的重要参考资料，可直接从专家处获得快速、经过验证的解答和设计帮助。搜索现有解答或提出自己的问题，获得所需的快速设计帮助。

链接的内容由各个贡献者“按原样”提供。这些内容并不构成 TI 技术规范，并且不一定反映 TI 的观点；请参阅 TI 的[使用条款](#)。

10.5 商标

TI E2E™ is a trademark of Texas Instruments.
所有商标均为其各自所有者的财产。

10.6 静电放电警告



静电放电 (ESD) 会损坏这个集成电路。德州仪器 (TI) 建议通过适当的预防措施处理所有集成电路。如果不遵守正确的处理和安装程序，可能会损坏集成电路。

ESD 的损坏小至导致微小的性能降级，大至整个器件故障。精密的集成电路可能更容易受到损坏，这是因为非常细微的参数更改都可能会导致器件与其发布的规格不相符。

10.7 术语表

TI 术语表 本术语表列出并解释了术语、首字母缩略词和定义。

11 修订历史记录

Changes from Revision R (August 2023) to Revision S (May 2024)	Page
• 更新了引脚图.....	4

Changes from Revision Q (July 2022) to Revision R (August 2023)	Page
• 更新了 <i>应用</i> 部分的链接.....	1
• 更新了 <i>说明</i> 部分.....	1
• 删除了 KTP 封装.....	4
• 添加了详细的 <i>温度系数</i> 和 <i>动态阻抗</i> 部分.....	20
• 更新了 <i>应用</i> 部分.....	27
• 更新了 <i>器件命名规则</i> 图中的 LP 封装.....	33

Changes from Revision P (November 2018) to Revision Q (July 2022)	Page
• 更新了整个文档中的表格、图和交叉参考的编号格式.....	1
• 更正了 <i>引脚功能表</i> 中的器件名称.....	4

Changes from Revision O (January 2015) to Revision P (November 2018)	Page
• 向 <i>说明</i> 部分添加了文本.....	1
• 添加了 TL43x 器件比较表	3
• 添加了 TL43x 器件命名规则 部分.....	33

Changes from Revision N (January 2014) to Revision O (January 2015)	Page
• 添加了 <i>应用</i> 、 <i>器件信息表</i> 、 <i>引脚功能表</i> 、 ESD 等级表、 <i>热性能信息表</i> 、 <i>特性说明</i> 部分、 <i>器件功能模式</i> 、 <i>应用和实施</i> 部分、 <i>电源相关建议</i> 部分、 <i>布局</i> 部分、 <i>器件和文档支持</i> 部分以及 <i>机械</i> 、 <i>封装和可订购信息</i> 部分。.	1
• 添加了“应用”	1

12 机械、封装和可订购信息

以下页面包含机械、封装和可订购信息。这些信息是指定器件可用的最新数据。数据如有变更，恕不另行通知，且不会对此文档进行修订。如需获取此数据表的浏览器版本，请查阅左侧的导航栏。

PACKAGING INFORMATION

Orderable part number	Status (1)	Material type (2)	Package Pins	Package qty Carrier	RoHS (3)	Lead finish/ Ball material (4)	MSL rating/ Peak reflow (5)	Op temp (°C)	Part marking (6)
TL431ACD	Active	Production	SOIC (D) 8	75 TUBE	Yes	NIPDAU	Level-1-260C-UNLIM	0 to 70	431AC
TL431ACD.A	Active	Production	SOIC (D) 8	75 TUBE	Yes	NIPDAU	Level-1-260C-UNLIM	0 to 70	431AC
TL431ACDBVR	Active	Production	SOT-23 (DBV) 5	3000 LARGE T&R	Yes	NIPDAU SN	Level-1-260C-UNLIM	0 to 70	(TACG, TACJ, TACS)
TL431ACDBVR.A	Active	Production	SOT-23 (DBV) 5	3000 LARGE T&R	Yes	SN	Level-1-260C-UNLIM	0 to 70	(TACG, TACJ, TACS)
TL431ACDBVRG4	Obsolete	Production	SOT-23 (DBV) 5	-	-	Call TI	Call TI	0 to 70	TACG
TL431ACDBVT	Active	Production	SOT-23 (DBV) 5	250 SMALL T&R	Yes	NIPDAU SN	Level-1-260C-UNLIM	0 to 70	(TACG, TACJ, TACU)
TL431ACDBVT.A	Active	Production	SOT-23 (DBV) 5	250 SMALL T&R	Yes	SN	Level-1-260C-UNLIM	0 to 70	(TACG, TACJ, TACU)
TL431ACDBZR	Active	Production	SOT-23 (DBZ) 3	3000 LARGE T&R	Yes	NIPDAU SN	Level-1-260C-UNLIM	0 to 70	(TAC3, TACG, TACS, TACU)
TL431ACDBZR.A	Active	Production	SOT-23 (DBZ) 3	3000 LARGE T&R	Yes	NIPDAU	Level-1-260C-UNLIM	0 to 70	(TAC3, TACG, TACS, TACU)
TL431ACDBZRG4	Active	Production	SOT-23 (DBZ) 3	3000 LARGE T&R	Yes	NIPDAU	Level-1-260C-UNLIM	0 to 70	TAC3
TL431ACDBZRG4.A	Active	Production	SOT-23 (DBZ) 3	3000 LARGE T&R	Yes	NIPDAU	Level-1-260C-UNLIM	0 to 70	TAC3
TL431ACDBZT	Active	Production	SOT-23 (DBZ) 3	250 SMALL T&R	Yes	NIPDAU SN	Level-1-260C-UNLIM	0 to 70	(TAC3, TACG, TACS, TACU)
TL431ACDBZT.A	Active	Production	SOT-23 (DBZ) 3	250 SMALL T&R	Yes	NIPDAU	Level-1-260C-UNLIM	0 to 70	(TAC3, TACG, TACS, TACU)
TL431ACDBZTG4	Active	Production	SOT-23 (DBZ) 3	250 SMALL T&R	Yes	NIPDAU	Level-1-260C-UNLIM	0 to 70	TAC3
TL431ACDBZTG4.A	Active	Production	SOT-23 (DBZ) 3	250 SMALL T&R	Yes	NIPDAU	Level-1-260C-UNLIM	0 to 70	TAC3
TL431ACDCKR	Active	Production	SC70 (DCK) 6	3000 LARGE T&R	Yes	NIPDAU SN	Level-1-260C-UNLIM	0 to 70	(T4S, T4U)
TL431ACDCKR.A	Active	Production	SC70 (DCK) 6	3000 LARGE T&R	Yes	SN	Level-1-260C-UNLIM	0 to 70	(T4S, T4U)
TL431ACDR	Active	Production	SOIC (D) 8	2500 LARGE T&R	Yes	NIPDAU	Level-1-260C-UNLIM	0 to 70	431AC
TL431ACDR.A	Active	Production	SOIC (D) 8	2500 LARGE T&R	Yes	NIPDAU	Level-1-260C-UNLIM	0 to 70	431AC
TL431ACDRG4	Obsolete	Production	SOIC (D) 8	-	-	Call TI	Call TI	0 to 70	431AC
TL431ACLPLP	Active	Production	TO-92 (LP) 3	1000 BULK	Yes	SN	N/A for Pkg Type	0 to 70	TL431AC
TL431ACLPLP.A	Active	Production	TO-92 (LP) 3	1000 BULK	Yes	SN	N/A for Pkg Type	0 to 70	TL431AC
TL431ACLPM	Active	Production	TO-92 (LP) 3	2000 AMMO	Yes	SN	N/A for Pkg Type	0 to 70	TL431AC

Orderable part number	Status (1)	Material type (2)	Package Pins	Package qty Carrier	RoHS (3)	Lead finish/ Ball material (4)	MSL rating/ Peak reflow (5)	Op temp (°C)	Part marking (6)
TL431ACLPM.A	Active	Production	TO-92 (LP) 3	2000 AMMO	Yes	SN	N/A for Pkg Type	0 to 70	TL431AC
TL431ACLPR	Active	Production	TO-92 (LP) 3	2000 LARGE T&R	Yes	SN	N/A for Pkg Type	0 to 70	TL431AC
TL431ACLPR.A	Active	Production	TO-92 (LP) 3	2000 LARGE T&R	Yes	SN	N/A for Pkg Type	0 to 70	TL431AC
TL431ACP	Active	Production	PDIP (P) 8	50 TUBE	Yes	NIPDAU	N/A for Pkg Type	0 to 70	TL431ACP
TL431ACP.A	Active	Production	PDIP (P) 8	50 TUBE	Yes	NIPDAU	N/A for Pkg Type	0 to 70	TL431ACP
TL431ACPK	Active	Production	SOT-89 (PK) 3	1000 LARGE T&R	Yes	SN	Level-2-260C-1 YEAR	0 to 70	4A
TL431ACPK.A	Active	Production	SOT-89 (PK) 3	1000 LARGE T&R	Yes	SN	Level-2-260C-1 YEAR	0 to 70	4A
TL431ACPSR	Active	Production	SO (PS) 8	2000 LARGE T&R	Yes	NIPDAU	Level-1-260C-UNLIM	0 to 70	T431A
TL431ACPSR.A	Active	Production	SO (PS) 8	2000 LARGE T&R	Yes	NIPDAU	Level-1-260C-UNLIM	0 to 70	T431A
TL431ACPWR	Active	Production	TSSOP (PW) 8	2000 LARGE T&R	Yes	NIPDAU	Level-1-260C-UNLIM	0 to 70	T431A
TL431ACPWR.A	Active	Production	TSSOP (PW) 8	2000 LARGE T&R	Yes	NIPDAU	Level-1-260C-UNLIM	0 to 70	T431A
TL431AID	Active	Production	SOIC (D) 8	75 TUBE	Yes	NIPDAU	Level-1-260C-UNLIM	-40 to 85	431AI
TL431AID.A	Active	Production	SOIC (D) 8	75 TUBE	Yes	NIPDAU	Level-1-260C-UNLIM	-40 to 85	431AI
TL431AIDBVR	Active	Production	SOT-23 (DBV) 5	3000 LARGE T&R	Yes	NIPDAU SN	Level-1-260C-UNLIM	-40 to 85	(TAIG, TAIJ, TAIS)
TL431AIDBVR.A	Active	Production	SOT-23 (DBV) 5	3000 LARGE T&R	Yes	SN	Level-1-260C-UNLIM	-40 to 85	(TAIG, TAIJ, TAIS)
TL431AIDBVRG4	Obsolete	Production	SOT-23 (DBV) 5	-	-	Call TI	Call TI	-40 to 85	TAIG
TL431AIDBVT	Active	Production	SOT-23 (DBV) 5	250 SMALL T&R	Yes	NIPDAU SN	Level-1-260C-UNLIM	-40 to 85	(TAIG, TAIJ, TAIU)
TL431AIDBVT.A	Active	Production	SOT-23 (DBV) 5	250 SMALL T&R	Yes	SN	Level-1-260C-UNLIM	-40 to 85	(TAIG, TAIJ, TAIU)
TL431AIDBZR	Active	Production	SOT-23 (DBZ) 3	3000 LARGE T&R	Yes	NIPDAU SN	Level-1-260C-UNLIM	-40 to 85	(T3AG, TAI3, TAIS, TAIU)
TL431AIDBZR.A	Active	Production	SOT-23 (DBZ) 3	3000 LARGE T&R	Yes	NIPDAU	Level-1-260C-UNLIM	-40 to 85	(T3AG, TAI3, TAIS, TAIU)
TL431AIDBZRG4	Active	Production	SOT-23 (DBZ) 3	3000 LARGE T&R	Yes	NIPDAU	Level-1-260C-UNLIM	-40 to 85	TAI3
TL431AIDBZRG4.A	Active	Production	SOT-23 (DBZ) 3	3000 LARGE T&R	Yes	NIPDAU	Level-1-260C-UNLIM	-40 to 85	TAI3
TL431AIDBZT	Active	Production	SOT-23 (DBZ) 3	250 SMALL T&R	Yes	NIPDAU SN	Level-1-260C-UNLIM	-40 to 85	(T3AG, TAI3, TAIS, TAIU)
TL431AIDBZT.A	Active	Production	SOT-23 (DBZ) 3	250 SMALL T&R	Yes	NIPDAU	Level-1-260C-UNLIM	-40 to 85	(T3AG, TAI3, TAIS, TAIU)
TL431AIDBZTG4	Active	Production	SOT-23 (DBZ) 3	250 SMALL T&R	Yes	NIPDAU	Level-1-260C-UNLIM	-40 to 85	TAI3

Orderable part number	Status (1)	Material type (2)	Package Pins	Package qty Carrier	RoHS (3)	Lead finish/ Ball material (4)	MSL rating/ Peak reflow (5)	Op temp (°C)	Part marking (6)
TL431AIDBZTG4.A	Active	Production	SOT-23 (DBZ) 3	250 SMALL T&R	Yes	NIPDAU	Level-1-260C-UNLIM	-40 to 85	TAI3
TL431AIDCKR	Active	Production	SC70 (DCK) 6	3000 LARGE T&R	Yes	NIPDAU SN	Level-1-260C-UNLIM	-40 to 85	T5U
TL431AIDCKR.A	Active	Production	SC70 (DCK) 6	3000 LARGE T&R	Yes	SN	Level-1-260C-UNLIM	-40 to 85	T5U
TL431AIDCKRE4	Active	Production	SC70 (DCK) 6	3000 LARGE T&R	-	Call TI	Call TI	-40 to 85	
TL431AIDCKRG4	Active	Production	SC70 (DCK) 6	3000 LARGE T&R	Yes	NIPDAU	Level-1-260C-UNLIM	-40 to 85	T5U
TL431AIDCKRG4.A	Active	Production	SC70 (DCK) 6	3000 LARGE T&R	Yes	NIPDAU	Level-1-260C-UNLIM	-40 to 85	T5U
TL431AIDCKT	Active	Production	SC70 (DCK) 6	250 SMALL T&R	Yes	NIPDAU SN	Level-1-260C-UNLIM	-40 to 85	T5U
TL431AIDCKT.A	Active	Production	SC70 (DCK) 6	250 SMALL T&R	Yes	SN	Level-1-260C-UNLIM	-40 to 85	T5U
TL431AIDR	Active	Production	SOIC (D) 8	2500 LARGE T&R	Yes	NIPDAU	Level-1-260C-UNLIM	-40 to 85	431AI
TL431AIDR.A	Active	Production	SOIC (D) 8	2500 LARGE T&R	Yes	NIPDAU	Level-1-260C-UNLIM	-40 to 85	431AI
TL431AIDRG4	Obsolete	Production	SOIC (D) 8	-	-	Call TI	Call TI	-40 to 85	431AI
TL431AILP	Active	Production	TO-92 (LP) 3	1000 BULK	Yes	SN	N/A for Pkg Type	-40 to 85	TL431AI
TL431AILP.A	Active	Production	TO-92 (LP) 3	1000 BULK	Yes	SN	N/A for Pkg Type	-40 to 85	TL431AI
TL431AILPM	Active	Production	TO-92 (LP) 3	2000 AMMO	Yes	SN	N/A for Pkg Type	-40 to 85	TL431AI
TL431AILPM.A	Active	Production	TO-92 (LP) 3	2000 AMMO	Yes	SN	N/A for Pkg Type	-40 to 85	TL431AI
TL431AILPR	Active	Production	TO-92 (LP) 3	2000 LARGE T&R	Yes	SN	N/A for Pkg Type	-40 to 85	TL431AI
TL431AILPR.A	Active	Production	TO-92 (LP) 3	2000 LARGE T&R	Yes	SN	N/A for Pkg Type	-40 to 85	TL431AI
TL431AIPK	Active	Production	SOT-89 (PK) 3	1000 LARGE T&R	Yes	SN	Level-2-260C-1 YEAR	-40 to 85	4B
TL431AIPK.A	Active	Production	SOT-89 (PK) 3	1000 LARGE T&R	Yes	SN	Level-2-260C-1 YEAR	-40 to 85	4B
TL431AQDBVR	Active	Production	SOT-23 (DBV) 5	3000 LARGE T&R	Yes	NIPDAU SN	Level-1-260C-UNLIM	-40 to 125	(TAQG, TAQJ, TAQU)
TL431AQDBVR.A	Active	Production	SOT-23 (DBV) 5	3000 LARGE T&R	Yes	SN	Level-1-260C-UNLIM	-40 to 125	(TAQG, TAQJ, TAQU)
TL431AQDBVT	Active	Production	SOT-23 (DBV) 5	250 SMALL T&R	Yes	NIPDAU SN	Level-1-260C-UNLIM	-40 to 125	(TAQG, TAQJ, TAQU)
TL431AQDBVT.A	Active	Production	SOT-23 (DBV) 5	250 SMALL T&R	Yes	SN	Level-1-260C-UNLIM	-40 to 125	(TAQG, TAQJ, TAQU)
TL431AQDBZR	Active	Production	SOT-23 (DBZ) 3	3000 LARGE T&R	Yes	NIPDAU SN NIPDAUAG	Level-1-260C-UNLIM	-40 to 125	(TAQ3, TAQG, TAQS, TAQU)
TL431AQDBZR.A	Active	Production	SOT-23 (DBZ) 3	3000 LARGE T&R	Yes	NIPDAU	Level-1-260C-UNLIM	-40 to 125	(TAQ3, TAQG, TAQS, TAQU)
TL431AQDBZRG4	Active	Production	SOT-23 (DBZ) 3	3000 LARGE T&R	Yes	NIPDAU NIPDAUAG	Level-1-260C-UNLIM	-40 to 125	TAQS

Orderable part number	Status (1)	Material type (2)	Package Pins	Package qty Carrier	RoHS (3)	Lead finish/ Ball material (4)	MSL rating/ Peak reflow (5)	Op temp (°C)	Part marking (6)
TL431AQDBZRG4.A	Active	Production	SOT-23 (DBZ) 3	3000 LARGE T&R	Yes	NIPDAU	Level-1-260C-UNLIM	-40 to 125	TAQS
TL431AQDBZT	Active	Production	SOT-23 (DBZ) 3	250 SMALL T&R	Yes	NIPDAU SN NIPDAUAG	Level-1-260C-UNLIM	-40 to 125	(TAQG, TAQS, TAQU)
TL431AQDBZT.A	Active	Production	SOT-23 (DBZ) 3	250 SMALL T&R	Yes	NIPDAU	Level-1-260C-UNLIM	-40 to 125	(TAQG, TAQS, TAQU)
TL431AQDBZTG4	Active	Production	SOT-23 (DBZ) 3	250 SMALL T&R	Yes	NIPDAU NIPDAUAG	Level-1-260C-UNLIM	-40 to 125	TAQS
TL431AQDBZTG4.A	Active	Production	SOT-23 (DBZ) 3	250 SMALL T&R	Yes	NIPDAU	Level-1-260C-UNLIM	-40 to 125	TAQS
TL431AQDCKR	Active	Production	SC70 (DCK) 6	3000 LARGE T&R	Yes	NIPDAU SN	Level-1-260C-UNLIM	-40 to 125	T7U
TL431AQDCKR.A	Active	Production	SC70 (DCK) 6	3000 LARGE T&R	Yes	SN	Level-1-260C-UNLIM	-40 to 125	T7U
TL431AQDCKT	Active	Production	SC70 (DCK) 6	250 SMALL T&R	Yes	NIPDAU SN	Level-1-260C-UNLIM	-40 to 125	T7U
TL431AQDCKT.A	Active	Production	SC70 (DCK) 6	250 SMALL T&R	Yes	SN	Level-1-260C-UNLIM	-40 to 125	T7U
TL431AQPK	Active	Production	SOT-89 (PK) 3	1000 LARGE T&R	Yes	SN	Level-2-260C-1 YEAR	-40 to 125	4D
TL431AQPK.A	Active	Production	SOT-89 (PK) 3	1000 LARGE T&R	Yes	SN	Level-2-260C-1 YEAR	-40 to 125	4D
TL431BCD	Active	Production	SOIC (D) 8	75 TUBE	Yes	NIPDAU	Level-1-260C-UNLIM	0 to 70	T431B
TL431BCD.A	Active	Production	SOIC (D) 8	75 TUBE	Yes	NIPDAU	Level-1-260C-UNLIM	0 to 70	T431B
TL431BCDBVR	Active	Production	SOT-23 (DBV) 5	3000 LARGE T&R	Yes	NIPDAU SN	Level-1-260C-UNLIM	0 to 70	(T3GG, T3GJ, T3GU)
TL431BCDBVR.A	Active	Production	SOT-23 (DBV) 5	3000 LARGE T&R	Yes	SN	Level-1-260C-UNLIM	0 to 70	(T3GG, T3GJ, T3GU)
TL431BCDBVT	Active	Production	SOT-23 (DBV) 5	250 SMALL T&R	Yes	NIPDAU SN	Level-1-260C-UNLIM	0 to 70	(T3GG, T3GJ, T3GU)
TL431BCDBVT.A	Active	Production	SOT-23 (DBV) 5	250 SMALL T&R	Yes	SN	Level-1-260C-UNLIM	0 to 70	(T3GG, T3GJ, T3GU)
TL431BCDBZR	Active	Production	SOT-23 (DBZ) 3	3000 LARGE T&R	Yes	NIPDAU SN	Level-1-260C-UNLIM	0 to 70	(T3G3, T3GG, T3GS, T3GU)
TL431BCDBZR.A	Active	Production	SOT-23 (DBZ) 3	3000 LARGE T&R	Yes	NIPDAU	Level-1-260C-UNLIM	0 to 70	(T3G3, T3GG, T3GS, T3GU)
TL431BCDBZRG4	Active	Production	SOT-23 (DBZ) 3	3000 LARGE T&R	Yes	NIPDAU	Level-1-260C-UNLIM	0 to 70	T3G3
TL431BCDBZRG4.A	Active	Production	SOT-23 (DBZ) 3	3000 LARGE T&R	Yes	NIPDAU	Level-1-260C-UNLIM	0 to 70	T3G3
TL431BCDBZT	Active	Production	SOT-23 (DBZ) 3	250 SMALL T&R	Yes	NIPDAU SN	Level-1-260C-UNLIM	0 to 70	(T3G3, T3GG, T3GS, T3GU)
TL431BCDBZT.A	Active	Production	SOT-23 (DBZ) 3	250 SMALL T&R	Yes	NIPDAU	Level-1-260C-UNLIM	0 to 70	(T3G3, T3GG, T3GS, T3GU)

Orderable part number	Status (1)	Material type (2)	Package Pins	Package qty Carrier	RoHS (3)	Lead finish/ Ball material (4)	MSL rating/ Peak reflow (5)	Op temp (°C)	Part marking (6)
TL431BCDBZTG4	Active	Production	SOT-23 (DBZ) 3	250 SMALL T&R	Yes	NIPDAU	Level-1-260C-UNLIM	0 to 70	T3G3
TL431BCDBZTG4.A	Active	Production	SOT-23 (DBZ) 3	250 SMALL T&R	Yes	NIPDAU	Level-1-260C-UNLIM	0 to 70	T3G3
TL431BCDCKR	Active	Production	SC70 (DCK) 6	3000 LARGE T&R	Yes	NIPDAU SN	Level-1-260C-UNLIM	0 to 70	T2U
TL431BCDCKR.A	Active	Production	SC70 (DCK) 6	3000 LARGE T&R	Yes	SN	Level-1-260C-UNLIM	0 to 70	T2U
TL431BCDCKT	Active	Production	SC70 (DCK) 6	250 SMALL T&R	Yes	NIPDAU SN	Level-1-260C-UNLIM	0 to 70	T2U
TL431BCDCKT.A	Active	Production	SC70 (DCK) 6	250 SMALL T&R	Yes	SN	Level-1-260C-UNLIM	0 to 70	T2U
TL431BCDE4	Active	Production	SOIC (D) 8	75 TUBE	-	Call TI	Call TI	0 to 70	
TL431BCDR	Active	Production	SOIC (D) 8	2500 LARGE T&R	Yes	NIPDAU	Level-1-260C-UNLIM	0 to 70	T431B
TL431BCDR.A	Active	Production	SOIC (D) 8	2500 LARGE T&R	Yes	NIPDAU	Level-1-260C-UNLIM	0 to 70	T431B
TL431BCLP	Active	Production	TO-92 (LP) 3	1000 BULK	Yes	SN	N/A for Pkg Type	0 to 70	T431B
TL431BCLP.A	Active	Production	TO-92 (LP) 3	1000 BULK	Yes	SN	N/A for Pkg Type	0 to 70	T431B
TL431BCLPR	Active	Production	TO-92 (LP) 3	2000 LARGE T&R	Yes	SN	N/A for Pkg Type	0 to 70	T431B
TL431BCLPR.A	Active	Production	TO-92 (LP) 3	2000 LARGE T&R	Yes	SN	N/A for Pkg Type	0 to 70	T431B
TL431BCPK	Active	Production	SOT-89 (PK) 3	1000 LARGE T&R	Yes	SN	Level-2-260C-1 YEAR	0 to 70	4C
TL431BCPK.A	Active	Production	SOT-89 (PK) 3	1000 LARGE T&R	Yes	SN	Level-2-260C-1 YEAR	0 to 70	4C
TL431BID	Active	Production	SOIC (D) 8	75 TUBE	Yes	NIPDAU	Level-1-260C-UNLIM	-40 to 85	Z431B
TL431BID.A	Active	Production	SOIC (D) 8	75 TUBE	Yes	NIPDAU	Level-1-260C-UNLIM	-40 to 85	Z431B
TL431BIDBVR	Active	Production	SOT-23 (DBV) 5	3000 LARGE T&R	Yes	NIPDAU SN	Level-1-260C-UNLIM	-40 to 85	(T3FG, T3FJ, T3FU)
TL431BIDBVR.A	Active	Production	SOT-23 (DBV) 5	3000 LARGE T&R	Yes	SN	Level-1-260C-UNLIM	-40 to 85	(T3FG, T3FJ, T3FU)
TL431BIDBVT	Active	Production	SOT-23 (DBV) 5	250 SMALL T&R	Yes	NIPDAU SN	Level-1-260C-UNLIM	-40 to 85	(T3FG, T3FJ, T3FU)
TL431BIDBVT.A	Active	Production	SOT-23 (DBV) 5	250 SMALL T&R	Yes	SN	Level-1-260C-UNLIM	-40 to 85	(T3FG, T3FJ, T3FU)
TL431BIDBZR	Active	Production	SOT-23 (DBZ) 3	3000 LARGE T&R	Yes	NIPDAU SN	Level-1-260C-UNLIM	-40 to 85	(T3F3, T3FG, T3FS, T3FU)
TL431BIDBZR.A	Active	Production	SOT-23 (DBZ) 3	3000 LARGE T&R	Yes	NIPDAU	Level-1-260C-UNLIM	-40 to 85	(T3F3, T3FG, T3FS, T3FU)
TL431BIDBZRG4	Active	Production	SOT-23 (DBZ) 3	3000 LARGE T&R	Yes	NIPDAU	Level-1-260C-UNLIM	-40 to 85	T3F3
TL431BIDBZRG4.A	Active	Production	SOT-23 (DBZ) 3	3000 LARGE T&R	Yes	NIPDAU	Level-1-260C-UNLIM	-40 to 85	T3F3

Orderable part number	Status (1)	Material type (2)	Package Pins	Package qty Carrier	RoHS (3)	Lead finish/ Ball material (4)	MSL rating/ Peak reflow (5)	Op temp (°C)	Part marking (6)
TL431BIDBZT	Active	Production	SOT-23 (DBZ) 3	250 SMALL T&R	Yes	NIPDAU SN	Level-1-260C-UNLIM	-40 to 85	(T3F3, T3FG, T3FS, T3FU)
TL431BIDBZT.A	Active	Production	SOT-23 (DBZ) 3	250 SMALL T&R	Yes	NIPDAU	Level-1-260C-UNLIM	-40 to 85	(T3F3, T3FG, T3FS, T3FU)
TL431BIDBZTG4	Active	Production	SOT-23 (DBZ) 3	250 SMALL T&R	Yes	NIPDAU	Level-1-260C-UNLIM	-40 to 85	T3F3
TL431BIDBZTG4.A	Active	Production	SOT-23 (DBZ) 3	250 SMALL T&R	Yes	NIPDAU	Level-1-260C-UNLIM	-40 to 85	T3F3
TL431BIDCKR	Active	Production	SC70 (DCK) 6	3000 LARGE T&R	Yes	NIPDAU SN	Level-1-260C-UNLIM	-40 to 85	T3U
TL431BIDCKR.A	Active	Production	SC70 (DCK) 6	3000 LARGE T&R	Yes	SN	Level-1-260C-UNLIM	-40 to 85	T3U
TL431BIDCKT	Active	Production	SC70 (DCK) 6	250 SMALL T&R	Yes	NIPDAU SN	Level-1-260C-UNLIM	-40 to 85	T3U
TL431BIDCKT.A	Active	Production	SC70 (DCK) 6	250 SMALL T&R	Yes	SN	Level-1-260C-UNLIM	-40 to 85	T3U
TL431BIDE4	Active	Production	SOIC (D) 8	75 TUBE	-	Call TI	Call TI	-40 to 85	
TL431BIDG4	Active	Production	SOIC (D) 8	75 TUBE	-	Call TI	Call TI	-40 to 85	
TL431BIDR	Active	Production	SOIC (D) 8	2500 LARGE T&R	Yes	NIPDAU	Level-1-260C-UNLIM	-40 to 85	Z431B
TL431BIDR.A	Active	Production	SOIC (D) 8	2500 LARGE T&R	Yes	NIPDAU	Level-1-260C-UNLIM	-40 to 85	Z431B
TL431BIDRG4	Obsolete	Production	SOIC (D) 8	-	-	Call TI	Call TI	-40 to 85	Z431B
TL431BILP	Active	Production	TO-92 (LP) 3	1000 BULK	Yes	SN	N/A for Pkg Type	-40 to 85	Z431B
TL431BILP.A	Active	Production	TO-92 (LP) 3	1000 BULK	Yes	SN	N/A for Pkg Type	-40 to 85	Z431B
TL431BILPR	Active	Production	TO-92 (LP) 3	2000 LARGE T&R	Yes	SN	N/A for Pkg Type	-40 to 85	Z431B
TL431BILPR.A	Active	Production	TO-92 (LP) 3	2000 LARGE T&R	Yes	SN	N/A for Pkg Type	-40 to 85	Z431B
TL431BIP	Obsolete	Production	PDIP (P) 8	-	-	Call TI	Call TI	-40 to 85	TL431BIP
TL431BIPK	Active	Production	SOT-89 (PK) 3	1000 LARGE T&R	Yes	SN	Level-2-260C-1 YEAR	-40 to 85	4I
TL431BIPK.A	Active	Production	SOT-89 (PK) 3	1000 LARGE T&R	Yes	SN	Level-2-260C-1 YEAR	-40 to 85	4I
TL431BQD	Active	Production	SOIC (D) 8	75 TUBE	Yes	NIPDAU	Level-1-260C-UNLIM	-40 to 125	T431BQ
TL431BQD.A	Active	Production	SOIC (D) 8	75 TUBE	Yes	NIPDAU	Level-1-260C-UNLIM	-40 to 125	T431BQ
TL431BQDBVR	Active	Production	SOT-23 (DBV) 5	3000 LARGE T&R	Yes	NIPDAU SN	Level-1-260C-UNLIM	-40 to 125	(T3HJ, T3HU)
TL431BQDBVR.A	Active	Production	SOT-23 (DBV) 5	3000 LARGE T&R	Yes	SN	Level-1-260C-UNLIM	-40 to 125	(T3HJ, T3HU)
TL431BQDBVT	Active	Production	SOT-23 (DBV) 5	250 SMALL T&R	Yes	NIPDAU SN	Level-1-260C-UNLIM	-40 to 125	(T3HJ, T3HU)
TL431BQDBVT.A	Active	Production	SOT-23 (DBV) 5	250 SMALL T&R	Yes	SN	Level-1-260C-UNLIM	-40 to 125	(T3HJ, T3HU)
TL431BQDBZR	Active	Production	SOT-23 (DBZ) 3	3000 LARGE T&R	Yes	NIPDAU SN NIPDAUAG	Level-1-260C-UNLIM	-40 to 125	(T3H3, T3HG, T3HS, T3HU)
TL431BQDBZR.A	Active	Production	SOT-23 (DBZ) 3	3000 LARGE T&R	Yes	NIPDAU	Level-1-260C-UNLIM	-40 to 125	(T3H3, T3HG, T3HS, T3HU)

Orderable part number	Status (1)	Material type (2)	Package Pins	Package qty Carrier	RoHS (3)	Lead finish/ Ball material (4)	MSL rating/ Peak reflow (5)	Op temp (°C)	Part marking (6)
TL431BQDBZRG4	Active	Production	SOT-23 (DBZ) 3	3000 LARGE T&R	Yes	NIPDAU NIPDAUAG	Level-1-260C-UNLIM	-40 to 125	T3HS
TL431BQDBZRG4.A	Active	Production	SOT-23 (DBZ) 3	3000 LARGE T&R	Yes	NIPDAU	Level-1-260C-UNLIM	-40 to 125	T3HS
TL431BQDBZT	Active	Production	SOT-23 (DBZ) 3	250 SMALL T&R	Yes	NIPDAU SN NIPDAUAG	Level-1-260C-UNLIM	-40 to 125	(T3HG, T3HS, T3HU)
TL431BQDBZT.A	Active	Production	SOT-23 (DBZ) 3	250 SMALL T&R	Yes	NIPDAU	Level-1-260C-UNLIM	-40 to 125	(T3HG, T3HS, T3HU)
TL431BQDBZTG4	Active	Production	SOT-23 (DBZ) 3	250 SMALL T&R	Yes	NIPDAU NIPDAUAG	Level-1-260C-UNLIM	-40 to 125	T3HS
TL431BQDBZTG4.A	Active	Production	SOT-23 (DBZ) 3	250 SMALL T&R	Yes	NIPDAU	Level-1-260C-UNLIM	-40 to 125	T3HS
TL431BQDCKR	Active	Production	SC70 (DCK) 6	3000 LARGE T&R	Yes	NIPDAU SN	Level-1-260C-UNLIM	-40 to 125	T8U
TL431BQDCKR.A	Active	Production	SC70 (DCK) 6	3000 LARGE T&R	Yes	SN	Level-1-260C-UNLIM	-40 to 125	T8U
TL431BQDCKT	Active	Production	SC70 (DCK) 6	250 SMALL T&R	Yes	NIPDAU SN	Level-1-260C-UNLIM	-40 to 125	T8U
TL431BQDCKT.A	Active	Production	SC70 (DCK) 6	250 SMALL T&R	Yes	SN	Level-1-260C-UNLIM	-40 to 125	T8U
TL431BQDE4	Active	Production	SOIC (D) 8	75 TUBE	-	Call TI	Call TI	-40 to 125	
TL431BQDR	Active	Production	SOIC (D) 8	2500 LARGE T&R	Yes	NIPDAU	Level-1-260C-UNLIM	-40 to 125	T431BQ
TL431BQDR.A	Active	Production	SOIC (D) 8	2500 LARGE T&R	Yes	NIPDAU	Level-1-260C-UNLIM	-40 to 125	T431BQ
TL431BQDRG4	Active	Production	SOIC (D) 8	2500 LARGE T&R	-	Call TI	Call TI	-40 to 125	
TL431BQLP	Active	Production	TO-92 (LP) 3	1000 BULK	Yes	SN	N/A for Pkg Type	-40 to 125	T431BQ
TL431BQLP.A	Active	Production	TO-92 (LP) 3	1000 BULK	Yes	SN	N/A for Pkg Type	-40 to 125	T431BQ
TL431BQLPM	Active	Production	TO-92 (LP) 3	2000 AMMO	Yes	SN	N/A for Pkg Type	-40 to 125	T431BQ
TL431BQLPM.A	Active	Production	TO-92 (LP) 3	2000 AMMO	Yes	SN	N/A for Pkg Type	-40 to 125	T431BQ
TL431BQLPR	Active	Production	TO-92 (LP) 3	2000 LARGE T&R	Yes	SN	N/A for Pkg Type	-40 to 125	T431BQ
TL431BQLPR.A	Active	Production	TO-92 (LP) 3	2000 LARGE T&R	Yes	SN	N/A for Pkg Type	-40 to 125	T431BQ
TL431BQPK	Active	Production	SOT-89 (PK) 3	1000 LARGE T&R	Yes	SN	Level-2-260C-1 YEAR	-40 to 125	3H
TL431BQPK.A	Active	Production	SOT-89 (PK) 3	1000 LARGE T&R	Yes	SN	Level-2-260C-1 YEAR	-40 to 125	3H
TL431CD	Active	Production	SOIC (D) 8	75 TUBE	Yes	NIPDAU	Level-1-260C-UNLIM	0 to 70	TL431C
TL431CD.A	Active	Production	SOIC (D) 8	75 TUBE	Yes	NIPDAU	Level-1-260C-UNLIM	0 to 70	TL431C
TL431CDBVR	Active	Production	SOT-23 (DBV) 5	3000 LARGE T&R	Yes	NIPDAU SN	Level-1-260C-UNLIM	0 to 70	(T3CG, T3CJ, T3CS)
TL431CDBVR.A	Active	Production	SOT-23 (DBV) 5	3000 LARGE T&R	Yes	SN	Level-1-260C-UNLIM	0 to 70	(T3CG, T3CJ, T3CS)
TL431CDBVT	Active	Production	SOT-23 (DBV) 5	250 SMALL T&R	Yes	NIPDAU SN	Level-1-260C-UNLIM	0 to 70	(T3CG, T3CJ, T3CS)

Orderable part number	Status (1)	Material type (2)	Package Pins	Package qty Carrier	RoHS (3)	Lead finish/ Ball material (4)	MSL rating/ Peak reflow (5)	Op temp (°C)	Part marking (6)
TL431CDBVT.A	Active	Production	SOT-23 (DBV) 5	250 SMALL T&R	Yes	SN	Level-1-260C-UNLIM	0 to 70	(T3CG, T3CJ, T3CS)
TL431CDBZR	Active	Production	SOT-23 (DBZ) 3	3000 LARGE T&R	Yes	NIPDAU SN	Level-1-260C-UNLIM	0 to 70	(T3C3, T3CG, T3CS, T3CU)
TL431CDBZR.A	Active	Production	SOT-23 (DBZ) 3	3000 LARGE T&R	Yes	NIPDAU	Level-1-260C-UNLIM	0 to 70	(T3C3, T3CG, T3CS, T3CU)
TL431CDBZRG4	Active	Production	SOT-23 (DBZ) 3	3000 LARGE T&R	Yes	NIPDAU	Level-1-260C-UNLIM	0 to 70	T3C3
TL431CDBZRG4.A	Active	Production	SOT-23 (DBZ) 3	3000 LARGE T&R	Yes	NIPDAU	Level-1-260C-UNLIM	0 to 70	T3C3
TL431CDBZT	Active	Production	SOT-23 (DBZ) 3	250 SMALL T&R	Yes	NIPDAU SN	Level-1-260C-UNLIM	0 to 70	(T3CG, T3CS, T3CU)
TL431CDBZT.A	Active	Production	SOT-23 (DBZ) 3	250 SMALL T&R	Yes	NIPDAU	Level-1-260C-UNLIM	0 to 70	(T3CG, T3CS, T3CU)
TL431CDBZTG4	Active	Production	SOT-23 (DBZ) 3	250 SMALL T&R	Yes	NIPDAU NIPDAUAG	Level-1-260C-UNLIM	0 to 70	T3CS
TL431CDBZTG4.A	Active	Production	SOT-23 (DBZ) 3	250 SMALL T&R	Yes	NIPDAU	Level-1-260C-UNLIM	0 to 70	T3CS
TL431CDG4	Active	Production	SOIC (D) 8	75 TUBE	-	Call TI	Call TI	0 to 70	
TL431CDR	Active	Production	SOIC (D) 8	2500 LARGE T&R	Yes	NIPDAU	Level-1-260C-UNLIM	0 to 70	TL431C
TL431CDR-J	Active	Production	SOIC (D) 8	2500 LARGE T&R	Yes	NIPDAU	Level-1-260C-UNLIM	0 to 70	TL431C
TL431CDR-J.A	Active	Production	SOIC (D) 8	2500 LARGE T&R	Yes	NIPDAU	Level-1-260C-UNLIM	0 to 70	TL431C
TL431CDR.A	Active	Production	SOIC (D) 8	2500 LARGE T&R	Yes	NIPDAU	Level-1-260C-UNLIM	0 to 70	TL431C
TL431CDRG4	Obsolete	Production	SOIC (D) 8	-	-	Call TI	Call TI	0 to 70	TL431C
TL431CLP	Active	Production	TO-92 (LP) 3	1000 BULK	Yes	SN	N/A for Pkg Type	0 to 70	TL431C
TL431CLP-Z	Active	Production	TO-92 (LP) 3	2000 AMMO	Yes	SN	N/A for Pkg Type	-	TL431C
TL431CLP-Z.A	Active	Production	TO-92 (LP) 3	2000 AMMO	Yes	SN	N/A for Pkg Type	See TL431CLP-Z	TL431C
TL431CLP.A	Active	Production	TO-92 (LP) 3	1000 BULK	Yes	SN	N/A for Pkg Type	0 to 70	TL431C
TL431CLPM	Active	Production	TO-92 (LP) 3	2000 AMMO	Yes	SN	N/A for Pkg Type	0 to 70	TL431C
TL431CLPM.A	Active	Production	TO-92 (LP) 3	2000 AMMO	Yes	SN	N/A for Pkg Type	0 to 70	TL431C
TL431CLPR	Active	Production	TO-92 (LP) 3	2000 LARGE T&R	Yes	SN	N/A for Pkg Type	0 to 70	TL431C
TL431CLPR.A	Active	Production	TO-92 (LP) 3	2000 LARGE T&R	Yes	SN	N/A for Pkg Type	0 to 70	TL431C
TL431CPK	Active	Production	SOT-89 (PK) 3	1000 LARGE T&R	Yes	SN	Level-2-260C-1 YEAR	0 to 70	43
TL431CPK.A	Active	Production	SOT-89 (PK) 3	1000 LARGE T&R	Yes	SN	Level-2-260C-1 YEAR	0 to 70	43
TL431CPKE6	Active	Production	SOT-89 (PK) 3	1000 LARGE T&R	Yes	SNBI	Level-1-260C-UNLIM	0 to 70	43
TL431CPKE6.A	Active	Production	SOT-89 (PK) 3	1000 LARGE T&R	Yes	SNBI	Level-1-260C-UNLIM	0 to 70	43

Orderable part number	Status (1)	Material type (2)	Package Pins	Package qty Carrier	RoHS (3)	Lead finish/ Ball material (4)	MSL rating/ Peak reflow (5)	Op temp (°C)	Part marking (6)
TL431CPSR	Obsolete	Production	SO (PS) 8	-	-	Call TI	Call TI	0 to 70	T431
TL431ID	Active	Production	SOIC (D) 8	75 TUBE	Yes	NIPDAU	Level-1-260C-UNLIM	-40 to 85	TL431I
TL431ID.A	Active	Production	SOIC (D) 8	75 TUBE	Yes	NIPDAU	Level-1-260C-UNLIM	-40 to 85	TL431I
TL431IDBVR	Active	Production	SOT-23 (DBV) 5	3000 LARGE T&R	Yes	NIPDAU SN	Level-1-260C-UNLIM	-40 to 85	(T3IG, T3IJ, T3IS)
TL431IDBVR.A	Active	Production	SOT-23 (DBV) 5	3000 LARGE T&R	Yes	SN	Level-1-260C-UNLIM	-40 to 85	(T3IG, T3IJ, T3IS)
TL431IDBVRG4	Obsolete	Production	SOT-23 (DBV) 5	-	-	Call TI	Call TI	-40 to 85	T3IG
TL431IDBVT	Active	Production	SOT-23 (DBV) 5	250 SMALL T&R	Yes	NIPDAU SN	Level-1-260C-UNLIM	-40 to 85	(T3IG, T3IJ, T3IU)
TL431IDBVT.A	Active	Production	SOT-23 (DBV) 5	250 SMALL T&R	Yes	SN	Level-1-260C-UNLIM	-40 to 85	(T3IG, T3IJ, T3IU)
TL431IDBZR	Active	Production	SOT-23 (DBZ) 3	3000 LARGE T&R	Yes	NIPDAU SN NIPDAUAG	Level-1-260C-UNLIM	-40 to 85	(T3I3, T3IG, T3IS, T3IU)
TL431IDBZR.A	Active	Production	SOT-23 (DBZ) 3	3000 LARGE T&R	Yes	NIPDAU	Level-1-260C-UNLIM	-40 to 85	(T3I3, T3IG, T3IS, T3IU)
TL431IDBZRG4	Active	Production	SOT-23 (DBZ) 3	3000 LARGE T&R	Yes	NIPDAU NIPDAUAG	Level-1-260C-UNLIM	-40 to 85	T3IS
TL431IDBZRG4.A	Active	Production	SOT-23 (DBZ) 3	3000 LARGE T&R	Yes	NIPDAU	Level-1-260C-UNLIM	-40 to 85	T3IS
TL431IDBZT	Active	Production	SOT-23 (DBZ) 3	250 SMALL T&R	Yes	NIPDAU SN NIPDAUAG	Level-1-260C-UNLIM	-40 to 85	(T3IG, T3IS, T3IU)
TL431IDBZT.A	Active	Production	SOT-23 (DBZ) 3	250 SMALL T&R	Yes	NIPDAU	Level-1-260C-UNLIM	-40 to 85	(T3IG, T3IS, T3IU)
TL431IDBZTG4	Active	Production	SOT-23 (DBZ) 3	250 SMALL T&R	Yes	NIPDAU NIPDAUAG	Level-1-260C-UNLIM	-40 to 85	T3IS
TL431IDBZTG4.A	Active	Production	SOT-23 (DBZ) 3	250 SMALL T&R	Yes	NIPDAU	Level-1-260C-UNLIM	-40 to 85	T3IS
TL431IDR	Active	Production	SOIC (D) 8	2500 LARGE T&R	Yes	NIPDAU	Level-1-260C-UNLIM	-40 to 85	TL431I
TL431IDR.A	Active	Production	SOIC (D) 8	2500 LARGE T&R	Yes	NIPDAU	Level-1-260C-UNLIM	-40 to 85	TL431I
TL431IDRG4	Obsolete	Production	SOIC (D) 8	-	-	Call TI	Call TI	-40 to 85	TL431I
TL431ILP	Active	Production	TO-92 (LP) 3	1000 BULK	Yes	SN	N/A for Pkg Type	-40 to 85	TL431I
TL431ILP.A	Active	Production	TO-92 (LP) 3	1000 BULK	Yes	SN	N/A for Pkg Type	-40 to 85	TL431I
TL431ILPR	Active	Production	TO-92 (LP) 3	2000 LARGE T&R	Yes	SN	N/A for Pkg Type	-40 to 85	TL431I
TL431ILPR.A	Active	Production	TO-92 (LP) 3	2000 LARGE T&R	Yes	SN	N/A for Pkg Type	-40 to 85	TL431I
TL431IP	Obsolete	Production	PDIP (P) 8	-	-	Call TI	Call TI	-40 to 85	TL431IP
TL431IPK	Active	Production	SOT-89 (PK) 3	1000 LARGE T&R	Yes	SN	Level-2-260C-1 YEAR	-40 to 85	3I

Orderable part number	Status (1)	Material type (2)	Package Pins	Package qty Carrier	RoHS (3)	Lead finish/ Ball material (4)	MSL rating/ Peak reflow (5)	Op temp (°C)	Part marking (6)
TL431IPK.A	Active	Production	SOT-89 (PK) 3	1000 LARGE T&R	Yes	SN	Level-2-260C-1 YEAR	-40 to 85	3I
TL431IPK3	Active	Production	SOT-89 (PK) 3	1000 LARGE T&R	Yes	SNBI	Level-1-260C-UNLIM	-40 to 85	3I
TL431IPK3.A	Active	Production	SOT-89 (PK) 3	1000 LARGE T&R	Yes	SNBI	Level-1-260C-UNLIM	-40 to 85	3I
TL431QD	Active	Production	SOIC (D) 8	75 TUBE	Yes	NIPDAU	Level-1-260C-UNLIM	-40 to 125	T431Q
TL431QD.A	Active	Production	SOIC (D) 8	75 TUBE	Yes	NIPDAU	Level-1-260C-UNLIM	-40 to 125	T431Q
TL431QDBVR	Active	Production	SOT-23 (DBV) 5	3000 LARGE T&R	Yes	NIPDAU SN	Level-1-260C-UNLIM	-40 to 125	(T3QG, T3QJ, T3QU)
TL431QDBVR.A	Active	Production	SOT-23 (DBV) 5	3000 LARGE T&R	Yes	SN	Level-1-260C-UNLIM	-40 to 125	(T3QG, T3QJ, T3QU)
TL431QDBVT	Active	Production	SOT-23 (DBV) 5	250 SMALL T&R	Yes	NIPDAU SN	Level-1-260C-UNLIM	-40 to 125	(T3QG, T3QJ, T3QU)
TL431QDBVT.A	Active	Production	SOT-23 (DBV) 5	250 SMALL T&R	Yes	SN	Level-1-260C-UNLIM	-40 to 125	(T3QG, T3QJ, T3QU)
TL431QDBZR	Active	Production	SOT-23 (DBZ) 3	3000 LARGE T&R	Yes	NIPDAU SN NIPDAUAG	Level-1-260C-UNLIM	-40 to 125	(T3Q3, T3QG, T3QS, T3QU)
TL431QDBZR.A	Active	Production	SOT-23 (DBZ) 3	3000 LARGE T&R	Yes	NIPDAU	Level-1-260C-UNLIM	-40 to 125	(T3Q3, T3QG, T3QS, T3QU)
TL431QDBZRG4	Active	Production	SOT-23 (DBZ) 3	3000 LARGE T&R	Yes	NIPDAU NIPDAUAG	Level-1-260C-UNLIM	-40 to 125	T3QS
TL431QDBZRG4.A	Active	Production	SOT-23 (DBZ) 3	3000 LARGE T&R	Yes	NIPDAU	Level-1-260C-UNLIM	-40 to 125	T3QS
TL431QDBZT	Active	Production	SOT-23 (DBZ) 3	250 SMALL T&R	Yes	NIPDAU SN NIPDAUAG	Level-1-260C-UNLIM	-40 to 125	(T3QG, T3QS, T3QU)
TL431QDBZT.A	Active	Production	SOT-23 (DBZ) 3	250 SMALL T&R	Yes	NIPDAU	Level-1-260C-UNLIM	-40 to 125	(T3QG, T3QS, T3QU)
TL431QDBZTG4	Active	Production	SOT-23 (DBZ) 3	250 SMALL T&R	Yes	NIPDAU NIPDAUAG	Level-1-260C-UNLIM	-40 to 125	T3QS
TL431QDBZTG4.A	Active	Production	SOT-23 (DBZ) 3	250 SMALL T&R	Yes	NIPDAU	Level-1-260C-UNLIM	-40 to 125	T3QS
TL431QDCKR	Active	Production	SC70 (DCK) 6	3000 LARGE T&R	Yes	NIPDAU SN	Level-1-260C-UNLIM	-40 to 125	T6U
TL431QDCKR.A	Active	Production	SC70 (DCK) 6	3000 LARGE T&R	Yes	SN	Level-1-260C-UNLIM	-40 to 125	T6U
TL431QDCKT	Active	Production	SC70 (DCK) 6	250 SMALL T&R	Yes	NIPDAU SN	Level-1-260C-UNLIM	-40 to 125	T6U
TL431QDCKT.A	Active	Production	SC70 (DCK) 6	250 SMALL T&R	Yes	SN	Level-1-260C-UNLIM	-40 to 125	T6U
TL431QDR	Active	Production	SOIC (D) 8	2500 LARGE T&R	Yes	NIPDAU	Level-1-260C-UNLIM	-40 to 125	T431Q
TL431QDR.A	Active	Production	SOIC (D) 8	2500 LARGE T&R	Yes	NIPDAU	Level-1-260C-UNLIM	-40 to 125	T431Q
TL431QPK	Active	Production	SOT-89 (PK) 3	1000 LARGE T&R	Yes	SN	Level-2-260C-1 YEAR	-40 to 125	3Q
TL431QPK.A	Active	Production	SOT-89 (PK) 3	1000 LARGE T&R	Yes	SN	Level-2-260C-1 YEAR	-40 to 125	3Q

Orderable part number	Status (1)	Material type (2)	Package Pins	Package qty Carrier	RoHS (3)	Lead finish/ Ball material (4)	MSL rating/ Peak reflow (5)	Op temp (°C)	Part marking (6)
TL432ACDBVR	Active	Production	SOT-23 (DBV) 5	3000 LARGE T&R	Yes	NIPDAU SN	Level-1-260C-UNLIM	0 to 70	(T4BG, T4BJ, T4BU)
TL432ACDBVR.A	Active	Production	SOT-23 (DBV) 5	3000 LARGE T&R	Yes	SN	Level-1-260C-UNLIM	0 to 70	(T4BG, T4BJ, T4BU)
TL432ACDBZR	Active	Production	SOT-23 (DBZ) 3	3000 LARGE T&R	Yes	NIPDAU SN NIPDAUAG	Level-1-260C-UNLIM	0 to 70	(T4B3, T4BG, T4BS, T4BU)
TL432ACDBZR.A	Active	Production	SOT-23 (DBZ) 3	3000 LARGE T&R	Yes	NIPDAU	Level-1-260C-UNLIM	0 to 70	(T4B3, T4BG, T4BS, T4BU)
TL432ACDBZRG4	Active	Production	SOT-23 (DBZ) 3	3000 LARGE T&R	Yes	NIPDAU NIPDAUAG	Level-1-260C-UNLIM	0 to 70	T4BS
TL432ACDBZRG4.A	Active	Production	SOT-23 (DBZ) 3	3000 LARGE T&R	Yes	NIPDAU	Level-1-260C-UNLIM	0 to 70	T4BS
TL432ACDBZT	Active	Production	SOT-23 (DBZ) 3	250 SMALL T&R	Yes	NIPDAU SN NIPDAUAG	Level-1-260C-UNLIM	0 to 70	(T4BG, T4BS, T4BU)
TL432ACDBZT.A	Active	Production	SOT-23 (DBZ) 3	250 SMALL T&R	Yes	NIPDAU	Level-1-260C-UNLIM	0 to 70	(T4BG, T4BS, T4BU)
TL432ACDBZTG4	Active	Production	SOT-23 (DBZ) 3	250 SMALL T&R	Yes	NIPDAU NIPDAUAG	Level-1-260C-UNLIM	0 to 70	T4BS
TL432ACDBZTG4.A	Active	Production	SOT-23 (DBZ) 3	250 SMALL T&R	Yes	NIPDAU	Level-1-260C-UNLIM	0 to 70	T4BS
TL432AIDBVR	Active	Production	SOT-23 (DBV) 5	3000 LARGE T&R	Yes	NIPDAU SN	Level-1-260C-UNLIM	-40 to 85	(T4AG, T4AJ, T4AU)
TL432AIDBVR.A	Active	Production	SOT-23 (DBV) 5	3000 LARGE T&R	Yes	SN	Level-1-260C-UNLIM	-40 to 85	(T4AG, T4AJ, T4AU)
TL432AIDBZR	Active	Production	SOT-23 (DBZ) 3	3000 LARGE T&R	Yes	NIPDAU SN	Level-1-260C-UNLIM	-40 to 85	(T4A3, T4AG, T4AS, T4AU)
TL432AIDBZR.A	Active	Production	SOT-23 (DBZ) 3	3000 LARGE T&R	Yes	NIPDAU	Level-1-260C-UNLIM	-40 to 85	(T4A3, T4AG, T4AS, T4AU)
TL432AIDBZRG4	Active	Production	SOT-23 (DBZ) 3	3000 LARGE T&R	Yes	NIPDAU	Level-1-260C-UNLIM	-40 to 85	T4A3
TL432AIDBZRG4.A	Active	Production	SOT-23 (DBZ) 3	3000 LARGE T&R	Yes	NIPDAU	Level-1-260C-UNLIM	-40 to 85	T4A3
TL432AIDBZT	Active	Production	SOT-23 (DBZ) 3	250 SMALL T&R	Yes	NIPDAU SN	Level-1-260C-UNLIM	-40 to 85	(T4A3, T4AG, T4AS, T4AU)
TL432AIDBZT.A	Active	Production	SOT-23 (DBZ) 3	250 SMALL T&R	Yes	NIPDAU	Level-1-260C-UNLIM	-40 to 85	(T4A3, T4AG, T4AS, T4AU)
TL432AIDBZTG4	Active	Production	SOT-23 (DBZ) 3	250 SMALL T&R	Yes	NIPDAU	Level-1-260C-UNLIM	-40 to 85	T4A3
TL432AIDBZTG4.A	Active	Production	SOT-23 (DBZ) 3	250 SMALL T&R	Yes	NIPDAU	Level-1-260C-UNLIM	-40 to 85	T4A3
TL432AIPK	Active	Production	SOT-89 (PK) 3	1000 LARGE T&R	Yes	SN	Level-2-260C-1 YEAR	-40 to 85	2E
TL432AIPK.A	Active	Production	SOT-89 (PK) 3	1000 LARGE T&R	Yes	SN	Level-2-260C-1 YEAR	-40 to 85	2E

Orderable part number	Status (1)	Material type (2)	Package Pins	Package qty Carrier	RoHS (3)	Lead finish/ Ball material (4)	MSL rating/ Peak reflow (5)	Op temp (°C)	Part marking (6)
TL432AQDBVR	Active	Production	SOT-23 (DBV) 5	3000 LARGE T&R	Yes	NIPDAU SN	Level-1-260C-UNLIM	-40 to 125	(T4DJ, T4DU)
TL432AQDBVR.A	Active	Production	SOT-23 (DBV) 5	3000 LARGE T&R	Yes	SN	Level-1-260C-UNLIM	-40 to 125	(T4DJ, T4DU)
TL432AQDBVT	Active	Production	SOT-23 (DBV) 5	250 SMALL T&R	Yes	NIPDAU SN	Level-1-260C-UNLIM	-40 to 125	(T4DJ, T4DU)
TL432AQDBVT.A	Active	Production	SOT-23 (DBV) 5	250 SMALL T&R	Yes	SN	Level-1-260C-UNLIM	-40 to 125	(T4DJ, T4DU)
TL432AQDBZR	Active	Production	SOT-23 (DBZ) 3	3000 LARGE T&R	Yes	NIPDAU SN NIPDAUAG	Level-1-260C-UNLIM	-40 to 125	(T4D3, T4DG, T4DS, T4DU)
TL432AQDBZR.A	Active	Production	SOT-23 (DBZ) 3	3000 LARGE T&R	Yes	NIPDAU	Level-1-260C-UNLIM	-40 to 125	(T4D3, T4DG, T4DS, T4DU)
TL432AQDBZRG4	Active	Production	SOT-23 (DBZ) 3	3000 LARGE T&R	Yes	NIPDAU NIPDAUAG	Level-1-260C-UNLIM	-40 to 125	T4DS
TL432AQDBZRG4.A	Active	Production	SOT-23 (DBZ) 3	3000 LARGE T&R	Yes	NIPDAU	Level-1-260C-UNLIM	-40 to 125	T4DS
TL432AQDBZT	Active	Production	SOT-23 (DBZ) 3	250 SMALL T&R	Yes	NIPDAU SN NIPDAUAG	Level-1-260C-UNLIM	-40 to 125	(T4DG, T4DS, T4DU)
TL432AQDBZT.A	Active	Production	SOT-23 (DBZ) 3	250 SMALL T&R	Yes	NIPDAU	Level-1-260C-UNLIM	-40 to 125	(T4DG, T4DS, T4DU)
TL432AQDBZTG4	Active	Production	SOT-23 (DBZ) 3	250 SMALL T&R	Yes	NIPDAU NIPDAUAG	Level-1-260C-UNLIM	-40 to 125	T4DS
TL432AQDBZTG4.A	Active	Production	SOT-23 (DBZ) 3	250 SMALL T&R	Yes	NIPDAU	Level-1-260C-UNLIM	-40 to 125	T4DS
TL432AQPK	Active	Production	SOT-89 (PK) 3	1000 LARGE T&R	Yes	SN	Level-2-260C-1 YEAR	-40 to 125	2F
TL432AQPK.A	Active	Production	SOT-89 (PK) 3	1000 LARGE T&R	Yes	SN	Level-2-260C-1 YEAR	-40 to 125	2F
TL432BCDBVR	Active	Production	SOT-23 (DBV) 5	3000 LARGE T&R	Yes	NIPDAU SN	Level-1-260C-UNLIM	0 to 70	(TBCJ, TBCU)
TL432BCDBVR.A	Active	Production	SOT-23 (DBV) 5	3000 LARGE T&R	Yes	SN	Level-1-260C-UNLIM	0 to 70	(TBCJ, TBCU)
TL432BCDBZR	Active	Production	SOT-23 (DBZ) 3	3000 LARGE T&R	Yes	NIPDAU SN NIPDAUAG	Level-1-260C-UNLIM	0 to 70	(TBCG, TBCS, TBCU)
TL432BCDBZR.A	Active	Production	SOT-23 (DBZ) 3	3000 LARGE T&R	Yes	NIPDAU	Level-1-260C-UNLIM	0 to 70	(TBCG, TBCS, TBCU)
TL432BCDBZRG4	Active	Production	SOT-23 (DBZ) 3	3000 LARGE T&R	Yes	NIPDAU NIPDAUAG	Level-1-260C-UNLIM	0 to 70	TBCS
TL432BCDBZRG4.A	Active	Production	SOT-23 (DBZ) 3	3000 LARGE T&R	Yes	NIPDAU	Level-1-260C-UNLIM	0 to 70	TBCS
TL432BCDBZT	Active	Production	SOT-23 (DBZ) 3	250 SMALL T&R	Yes	NIPDAU SN	Level-1-260C-UNLIM	0 to 70	(TBCG, TBCS, TBCU)
TL432BCDBZT.A	Active	Production	SOT-23 (DBZ) 3	250 SMALL T&R	Yes	NIPDAU	Level-1-260C-UNLIM	0 to 70	(TBCG, TBCS, TBCU)
TL432BCDBZTG4	Active	Production	SOT-23 (DBZ) 3	250 SMALL T&R	Yes	NIPDAU NIPDAUAG	Level-1-260C-UNLIM	0 to 70	TBCS
TL432BCDBZTG4.A	Active	Production	SOT-23 (DBZ) 3	250 SMALL T&R	Yes	NIPDAU	Level-1-260C-UNLIM	0 to 70	TBCS
TL432BCPK	Active	Production	SOT-89 (PK) 3	1000 LARGE T&R	Yes	SN	Level-2-260C-1 YEAR	0 to 70	2G

Orderable part number	Status (1)	Material type (2)	Package Pins	Package qty Carrier	RoHS (3)	Lead finish/ Ball material (4)	MSL rating/ Peak reflow (5)	Op temp (°C)	Part marking (6)
TL432BCPK.A	Active	Production	SOT-89 (PK) 3	1000 LARGE T&R	Yes	SN	Level-2-260C-1 YEAR	0 to 70	2G
TL432BIDBZR	Active	Production	SOT-23 (DBZ) 3	3000 LARGE T&R	Yes	NIPDAU SN	Level-1-260C-UNLIM	-40 to 85	(T4F3, T4FG, T4FS, T4FU)
TL432BIDBZR.A	Active	Production	SOT-23 (DBZ) 3	3000 LARGE T&R	Yes	NIPDAU	Level-1-260C-UNLIM	-40 to 85	(T4F3, T4FG, T4FS, T4FU)
TL432BIDBZRG4	Active	Production	SOT-23 (DBZ) 3	3000 LARGE T&R	Yes	NIPDAU	Level-1-260C-UNLIM	-40 to 85	T4F3
TL432BIDBZRG4.A	Active	Production	SOT-23 (DBZ) 3	3000 LARGE T&R	Yes	NIPDAU	Level-1-260C-UNLIM	-40 to 85	T4F3
TL432BIDBZT	Active	Production	SOT-23 (DBZ) 3	250 SMALL T&R	Yes	NIPDAU SN	Level-1-260C-UNLIM	-40 to 85	(T4F3, T4FG, T4FS, T4FU)
TL432BIDBZT.A	Active	Production	SOT-23 (DBZ) 3	250 SMALL T&R	Yes	NIPDAU	Level-1-260C-UNLIM	-40 to 85	(T4F3, T4FG, T4FS, T4FU)
TL432BIDBZTG4	Active	Production	SOT-23 (DBZ) 3	250 SMALL T&R	Yes	NIPDAU	Level-1-260C-UNLIM	-40 to 85	T4F3
TL432BIDBZTG4.A	Active	Production	SOT-23 (DBZ) 3	250 SMALL T&R	Yes	NIPDAU	Level-1-260C-UNLIM	-40 to 85	T4F3
TL432BIPK	Active	Production	SOT-89 (PK) 3	1000 LARGE T&R	Yes	SN	Level-2-260C-1 YEAR	-40 to 85	2H
TL432BIPK.A	Active	Production	SOT-89 (PK) 3	1000 LARGE T&R	Yes	SN	Level-2-260C-1 YEAR	-40 to 85	2H
TL432BQDBZR	Active	Production	SOT-23 (DBZ) 3	3000 LARGE T&R	Yes	NIPDAU NIPDAUAG	Level-1-260C-UNLIM	-40 to 125	(T4H3, T4HS, T4HU)
TL432BQDBZR.A	Active	Production	SOT-23 (DBZ) 3	3000 LARGE T&R	Yes	NIPDAU	Level-1-260C-UNLIM	-40 to 125	(T4H3, T4HS, T4HU)
TL432BQDBZR1G4	Active	Production	SOT-23 (DBZ) 3	3000 LARGE T&R	Yes	NIPDAU	Level-1-260C-UNLIM	-40 to 125	T4H3
TL432BQDBZR1G4.A	Active	Production	SOT-23 (DBZ) 3	3000 LARGE T&R	Yes	NIPDAU	Level-1-260C-UNLIM	-40 to 125	T4H3
TL432BQPK	Active	Production	SOT-89 (PK) 3	1000 LARGE T&R	Yes	SN	Level-2-260C-1 YEAR	-40 to 125	2J
TL432BQPK.A	Active	Production	SOT-89 (PK) 3	1000 LARGE T&R	Yes	SN	Level-2-260C-1 YEAR	-40 to 125	2J
TL432CDBVR	Active	Production	SOT-23 (DBV) 5	3000 LARGE T&R	Yes	NIPDAU SN	Level-1-260C-UNLIM	0 to 70	(T4CG, T4CJ, T4CU)
TL432CDBVR.A	Active	Production	SOT-23 (DBV) 5	3000 LARGE T&R	Yes	SN	Level-1-260C-UNLIM	0 to 70	(T4CG, T4CJ, T4CU)
TL432CDBZR	Active	Production	SOT-23 (DBZ) 3	3000 LARGE T&R	Yes	NIPDAU SN NIPDAUAG	Level-1-260C-UNLIM	0 to 70	(T4CG, T4CS, T4CU)
TL432CDBZR.A	Active	Production	SOT-23 (DBZ) 3	3000 LARGE T&R	Yes	NIPDAU	Level-1-260C-UNLIM	0 to 70	(T4CG, T4CS, T4CU)
TL432CDBZRG4	Active	Production	SOT-23 (DBZ) 3	3000 LARGE T&R	Yes	NIPDAU NIPDAUAG	Level-1-260C-UNLIM	0 to 70	T4CS
TL432CDBZRG4.A	Active	Production	SOT-23 (DBZ) 3	3000 LARGE T&R	Yes	NIPDAU	Level-1-260C-UNLIM	0 to 70	T4CS

Orderable part number	Status (1)	Material type (2)	Package Pins	Package qty Carrier	RoHS (3)	Lead finish/ Ball material (4)	MSL rating/ Peak reflow (5)	Op temp (°C)	Part marking (6)
TL432CPK	Active	Production	SOT-89 (PK) 3	1000 LARGE T&R	Yes	SN	Level-2-260C-1 YEAR	0 to 70	2A
TL432CPK.A	Active	Production	SOT-89 (PK) 3	1000 LARGE T&R	Yes	SN	Level-2-260C-1 YEAR	0 to 70	2A
TL432IDBVR	Active	Production	SOT-23 (DBV) 5	3000 LARGE T&R	Yes	NIPDAU SN	Level-1-260C-UNLIM	-40 to 85	(T4IG, T4IJ, T4IU)
TL432IDBVR.A	Active	Production	SOT-23 (DBV) 5	3000 LARGE T&R	Yes	SN	Level-1-260C-UNLIM	-40 to 85	(T4IG, T4IJ, T4IU)
TL432IDBZR	Active	Production	SOT-23 (DBZ) 3	3000 LARGE T&R	Yes	NIPDAU SN NIPDAUAG	Level-1-260C-UNLIM	-40 to 85	(T4IG, T4IS, T4IU)
TL432IDBZR.A	Active	Production	SOT-23 (DBZ) 3	3000 LARGE T&R	Yes	NIPDAU	Level-1-260C-UNLIM	-40 to 85	(T4IG, T4IS, T4IU)
TL432IDBZRG4	Active	Production	SOT-23 (DBZ) 3	3000 LARGE T&R	Yes	NIPDAU NIPDAUAG	Level-1-260C-UNLIM	-40 to 85	T4IS
TL432IDBZRG4.A	Active	Production	SOT-23 (DBZ) 3	3000 LARGE T&R	Yes	NIPDAU	Level-1-260C-UNLIM	-40 to 85	T4IS
TL432IDBZT	Active	Production	SOT-23 (DBZ) 3	250 SMALL T&R	Yes	NIPDAU SN NIPDAUAG	Level-1-260C-UNLIM	-40 to 85	(T4IG, T4IS, T4IU)
TL432IDBZT.A	Active	Production	SOT-23 (DBZ) 3	250 SMALL T&R	Yes	NIPDAU	Level-1-260C-UNLIM	-40 to 85	(T4IG, T4IS, T4IU)
TL432IDBZTG4	Active	Production	SOT-23 (DBZ) 3	250 SMALL T&R	Yes	NIPDAU NIPDAUAG	Level-1-260C-UNLIM	-40 to 85	T4IS
TL432IDBZTG4.A	Active	Production	SOT-23 (DBZ) 3	250 SMALL T&R	Yes	NIPDAU	Level-1-260C-UNLIM	-40 to 85	T4IS
TL432IPK	Active	Production	SOT-89 (PK) 3	1000 LARGE T&R	Yes	SN	Level-2-260C-1 YEAR	-40 to 85	2B
TL432IPK.A	Active	Production	SOT-89 (PK) 3	1000 LARGE T&R	Yes	SN	Level-2-260C-1 YEAR	-40 to 85	2B
TL432QDBZR	Active	Production	SOT-23 (DBZ) 3	3000 LARGE T&R	Yes	NIPDAU SN NIPDAUAG	Level-1-260C-UNLIM	-40 to 125	(T4QG, T4QS, T4QU)
TL432QDBZR.A	Active	Production	SOT-23 (DBZ) 3	3000 LARGE T&R	Yes	NIPDAU	Level-1-260C-UNLIM	-40 to 125	(T4QG, T4QS, T4QU)
TL432QDBZRG4	Active	Production	SOT-23 (DBZ) 3	3000 LARGE T&R	Yes	NIPDAU NIPDAUAG	Level-1-260C-UNLIM	-40 to 125	T4QS
TL432QDBZRG4.A	Active	Production	SOT-23 (DBZ) 3	3000 LARGE T&R	Yes	NIPDAU	Level-1-260C-UNLIM	-40 to 125	T4QS
TL432QPK	Active	Production	SOT-89 (PK) 3	1000 LARGE T&R	Yes	SN	Level-2-260C-1 YEAR	-40 to 125	2C
TL432QPK.A	Active	Production	SOT-89 (PK) 3	1000 LARGE T&R	Yes	SN	Level-2-260C-1 YEAR	-40 to 125	2C

(1) **Status:** For more details on status, see our [product life cycle](#).

(2) **Material type:** When designated, preproduction parts are prototypes/experimental devices, and are not yet approved or released for full production. Testing and final process, including without limitation quality assurance, reliability performance testing, and/or process qualification, may not yet be complete, and this item is subject to further changes or possible discontinuation. If available for ordering, purchases will be subject to an additional waiver at checkout, and are intended for early internal evaluation purposes only. These items are sold without warranties of any kind.

(3) **RoHS values:** Yes, No, RoHS Exempt. See the [TI RoHS Statement](#) for additional information and value definition.

(4) **Lead finish/Ball material:** Parts may have multiple material finish options. Finish options are separated by a vertical ruled line. Lead finish/Ball material values may wrap to two lines if the finish value exceeds the maximum column width.

(5) **MSL rating/Peak reflow:** The moisture sensitivity level ratings and peak solder (reflow) temperatures. In the event that a part has multiple moisture sensitivity ratings, only the lowest level per JEDEC standards is shown. Refer to the shipping label for the actual reflow temperature that will be used to mount the part to the printed circuit board.

(6) **Part marking:** There may be an additional marking, which relates to the logo, the lot trace code information, or the environmental category of the part.

Multiple part markings will be inside parentheses. Only one part marking contained in parentheses and separated by a "~" will appear on a part. If a line is indented then it is a continuation of the previous line and the two combined represent the entire part marking for that device.

Important Information and Disclaimer:The information provided on this page represents TI's knowledge and belief as of the date that it is provided. TI bases its knowledge and belief on information provided by third parties, and makes no representation or warranty as to the accuracy of such information. Efforts are underway to better integrate information from third parties. TI has taken and continues to take reasonable steps to provide representative and accurate information but may not have conducted destructive testing or chemical analysis on incoming materials and chemicals. TI and TI suppliers consider certain information to be proprietary, and thus CAS numbers and other limited information may not be available for release.

In no event shall TI's liability arising out of such information exceed the total purchase price of the TI part(s) at issue in this document sold by TI to Customer on an annual basis.

OTHER QUALIFIED VERSIONS OF TL431, TL432 :

- Automotive : [TL431-Q1](#), [TL432-Q1](#)

NOTE: Qualified Version Definitions:

- Automotive - Q100 devices qualified for high-reliability automotive applications targeting zero defects

TAPE AND REEL INFORMATION

QUADRANT ASSIGNMENTS FOR PIN 1 ORIENTATION IN TAPE

*All dimensions are nominal

Device	Package Type	Package Drawing	Pins	SPQ	Reel Diameter (mm)	Reel Width W1 (mm)	A0 (mm)	B0 (mm)	K0 (mm)	P1 (mm)	W (mm)	Pin1 Quadrant
TL431ACDBVR	SOT-23	DBV	5	3000	180.0	8.4	3.2	3.2	1.4	4.0	8.0	Q3
TL431ACDBVT	SOT-23	DBV	5	250	180.0	8.4	3.2	3.2	1.4	4.0	8.0	Q3
TL431ACDBVT	SOT-23	DBV	5	250	180.0	8.4	3.2	3.2	1.4	4.0	8.0	Q3
TL431ACDBZR	SOT-23	DBZ	3	3000	180.0	8.4	2.9	3.35	1.35	4.0	8.0	Q3
TL431ACDBZRG4	SOT-23	DBZ	3	3000	180.0	8.4	2.9	3.35	1.35	4.0	8.0	Q3
TL431ACDBZT	SOT-23	DBZ	3	250	180.0	8.4	2.9	3.35	1.35	4.0	8.0	Q3
TL431ACDBZT	SOT-23	DBZ	3	250	180.0	8.4	3.2	2.85	1.3	4.0	8.0	Q3
TL431ACDBZTG4	SOT-23	DBZ	3	250	180.0	8.4	2.9	3.35	1.35	4.0	8.0	Q3
TL431ACDCKR	SC70	DCK	6	3000	180.0	8.4	2.41	2.41	1.2	4.0	8.0	Q3
TL431ACDCKR	SC70	DCK	6	3000	180.0	8.4	2.3	2.5	1.2	4.0	8.0	Q3
TL431ACDR	SOIC	D	8	2500	330.0	12.4	6.4	5.2	2.1	8.0	12.0	Q1
TL431ACPK	SOT-89	PK	3	1000	180.0	12.4	4.91	4.52	1.9	8.0	12.0	Q3
TL431ACPK	SOT-89	PK	3	1000	180.0	12.4	4.91	4.52	1.9	8.0	12.0	Q3
TL431ACPSR	SO	PS	8	2000	330.0	16.4	8.35	6.6	2.4	12.0	16.0	Q1
TL431ACPWR	TSSOP	PW	8	2000	330.0	12.4	7.0	3.6	1.6	8.0	12.0	Q1
TL431AIDBVR	SOT-23	DBV	5	3000	180.0	8.4	3.2	3.2	1.4	4.0	8.0	Q3

Device	Package Type	Package Drawing	Pins	SPQ	Reel Diameter (mm)	Reel Width W1 (mm)	A0 (mm)	B0 (mm)	K0 (mm)	P1 (mm)	W (mm)	Pin1 Quadrant
TL431AIDBVT	SOT-23	DBV	5	250	180.0	8.4	3.2	3.2	1.4	4.0	8.0	Q3
TL431AIDBVT	SOT-23	DBV	5	250	180.0	8.4	3.2	3.2	1.4	4.0	8.0	Q3
TL431AIDBZR	SOT-23	DBZ	3	3000	180.0	8.4	2.9	3.35	1.35	4.0	8.0	Q3
TL431AIDBZRG4	SOT-23	DBZ	3	3000	180.0	8.4	2.9	3.35	1.35	4.0	8.0	Q3
TL431AIDBZT	SOT-23	DBZ	3	250	180.0	8.4	3.2	2.85	1.3	4.0	8.0	Q3
TL431AIDBZT	SOT-23	DBZ	3	250	180.0	8.4	2.9	3.35	1.35	4.0	8.0	Q3
TL431AIDBZTG4	SOT-23	DBZ	3	250	180.0	8.4	2.9	3.35	1.35	4.0	8.0	Q3
TL431AIDCKR	SC70	DCK	6	3000	179.0	8.4	2.2	2.5	1.2	4.0	8.0	Q3
TL431AIDCKR	SC70	DCK	6	3000	180.0	8.4	2.3	2.5	1.2	4.0	8.0	Q3
TL431AIDCKRG4	SC70	DCK	6	3000	179.0	8.4	2.2	2.5	1.2	4.0	8.0	Q3
TL431AIDCKT	SC70	DCK	6	250	180.0	8.4	2.3	2.5	1.2	4.0	8.0	Q3
TL431AIDCKT	SC70	DCK	6	250	179.0	8.4	2.2	2.5	1.2	4.0	8.0	Q3
TL431AIDR	SOIC	D	8	2500	330.0	12.4	6.4	5.2	2.1	8.0	12.0	Q1
TL431AIPK	SOT-89	PK	3	1000	180.0	12.4	4.91	4.52	1.9	8.0	12.0	Q3
TL431AIPK	SOT-89	PK	3	1000	180.0	12.4	4.91	4.52	1.9	8.0	12.0	Q3
TL431AQDBVR	SOT-23	DBV	5	3000	180.0	8.4	3.2	3.2	1.4	4.0	8.0	Q3
TL431AQDBVT	SOT-23	DBV	5	250	180.0	8.4	3.2	3.2	1.4	4.0	8.0	Q3
TL431AQDBZR	SOT-23	DBZ	3	3000	180.0	8.4	2.9	3.35	1.35	4.0	8.0	Q3
TL431AQDBZRG4	SOT-23	DBZ	3	3000	180.0	8.4	2.9	3.35	1.35	4.0	8.0	Q3
TL431AQDBZT	SOT-23	DBZ	3	250	180.0	8.4	2.9	3.35	1.35	4.0	8.0	Q3
TL431AQDBZT	SOT-23	DBZ	3	250	180.0	8.4	3.2	2.85	1.3	4.0	8.0	Q3
TL431AQDBZTG4	SOT-23	DBZ	3	250	180.0	8.4	2.9	3.35	1.35	4.0	8.0	Q3
TL431AQDCKR	SC70	DCK	6	3000	179.0	8.4	2.2	2.5	1.2	4.0	8.0	Q3
TL431AQDCKR	SC70	DCK	6	3000	180.0	8.4	2.3	2.5	1.2	4.0	8.0	Q3
TL431AQDCKT	SC70	DCK	6	250	179.0	8.4	2.2	2.5	1.2	4.0	8.0	Q3
TL431AQDCKT	SC70	DCK	6	250	180.0	8.4	2.3	2.5	1.2	4.0	8.0	Q3
TL431AQP	SOT-89	PK	3	1000	180.0	12.4	4.91	4.52	1.9	8.0	12.0	Q3
TL431AQP	SOT-89	PK	3	1000	180.0	12.4	4.91	4.52	1.9	8.0	12.0	Q3
TL431BCDBVR	SOT-23	DBV	5	3000	180.0	8.4	3.2	3.2	1.4	4.0	8.0	Q3
TL431BCDBVT	SOT-23	DBV	5	250	180.0	8.4	3.2	3.2	1.4	4.0	8.0	Q3
TL431BCDBVT	SOT-23	DBV	5	250	180.0	8.4	3.2	3.2	1.4	4.0	8.0	Q3
TL431BCDBZR	SOT-23	DBZ	3	3000	180.0	8.4	2.9	3.35	1.35	4.0	8.0	Q3
TL431BCDBZRG4	SOT-23	DBZ	3	3000	180.0	8.4	2.9	3.35	1.35	4.0	8.0	Q3
TL431BCDBZT	SOT-23	DBZ	3	250	180.0	8.4	3.2	2.85	1.3	4.0	8.0	Q3
TL431BCDBZT	SOT-23	DBZ	3	250	180.0	8.4	2.9	3.35	1.35	4.0	8.0	Q3
TL431BCDBZTG4	SOT-23	DBZ	3	250	180.0	8.4	2.9	3.35	1.35	4.0	8.0	Q3
TL431BCDCKR	SC70	DCK	6	3000	180.0	8.4	2.3	2.5	1.2	4.0	8.0	Q3
TL431BCDCKR	SC70	DCK	6	3000	179.0	8.4	2.2	2.5	1.2	4.0	8.0	Q3
TL431BCDCKT	SC70	DCK	6	250	179.0	8.4	2.2	2.5	1.2	4.0	8.0	Q3
TL431BCDCKT	SC70	DCK	6	250	180.0	8.4	2.3	2.5	1.2	4.0	8.0	Q3
TL431BCDR	SOIC	D	8	2500	330.0	12.4	6.4	5.2	2.1	8.0	12.0	Q1

Device	Package Type	Package Drawing	Pins	SPQ	Reel Diameter (mm)	Reel Width W1 (mm)	A0 (mm)	B0 (mm)	K0 (mm)	P1 (mm)	W (mm)	Pin1 Quadrant
TL431BCDR	SOIC	D	8	2500	330.0	12.4	6.4	5.2	2.1	8.0	12.0	Q1
TL431BCPK	SOT-89	PK	3	1000	180.0	12.4	4.91	4.52	1.9	8.0	12.0	Q3
TL431BCPK	SOT-89	PK	3	1000	180.0	12.4	4.91	4.52	1.9	8.0	12.0	Q3
TL431BIDBVR	SOT-23	DBV	5	3000	178.0	8.4	3.2	3.2	1.4	4.0	8.0	Q3
TL431BIDBVT	SOT-23	DBV	5	250	180.0	8.4	3.2	3.2	1.4	4.0	8.0	Q3
TL431BIDBZR	SOT-23	DBZ	3	3000	180.0	8.4	2.9	3.35	1.35	4.0	8.0	Q3
TL431BIDBZRG4	SOT-23	DBZ	3	3000	180.0	8.4	2.9	3.35	1.35	4.0	8.0	Q3
TL431BIDBZT	SOT-23	DBZ	3	250	180.0	8.4	3.2	2.85	1.3	4.0	8.0	Q3
TL431BIDBZT	SOT-23	DBZ	3	250	180.0	8.4	2.9	3.35	1.35	4.0	8.0	Q3
TL431BIDBZTG4	SOT-23	DBZ	3	250	180.0	8.4	2.9	3.35	1.35	4.0	8.0	Q3
TL431BIDCKR	SC70	DCK	6	3000	179.0	8.4	2.2	2.5	1.2	4.0	8.0	Q3
TL431BIDCKR	SC70	DCK	6	3000	180.0	8.4	2.3	2.5	1.2	4.0	8.0	Q3
TL431BIDCKT	SC70	DCK	6	250	179.0	8.4	2.2	2.5	1.2	4.0	8.0	Q3
TL431BIDCKT	SC70	DCK	6	250	180.0	8.4	2.3	2.5	1.2	4.0	8.0	Q3
TL431BIDR	SOIC	D	8	2500	330.0	12.4	6.4	5.2	2.1	8.0	12.0	Q1
TL431BIDR	SOIC	D	8	2500	330.0	12.4	6.4	5.2	2.1	8.0	12.0	Q1
TL431BIPK	SOT-89	PK	3	1000	180.0	12.4	4.91	4.52	1.9	8.0	12.0	Q3
TL431BIPK	SOT-89	PK	3	1000	180.0	12.4	4.91	4.52	1.9	8.0	12.0	Q3
TL431BQDBVR	SOT-23	DBV	5	3000	180.0	8.4	3.2	3.2	1.4	4.0	8.0	Q3
TL431BQDBVT	SOT-23	DBV	5	250	180.0	8.4	3.2	3.2	1.4	4.0	8.0	Q3
TL431BQDBVT	SOT-23	DBV	5	250	180.0	8.4	3.2	3.2	1.4	4.0	8.0	Q3
TL431BQDBZR	SOT-23	DBZ	3	3000	180.0	8.4	2.9	3.35	1.35	4.0	8.0	Q3
TL431BQDBZRG4	SOT-23	DBZ	3	3000	180.0	8.4	2.9	3.35	1.35	4.0	8.0	Q3
TL431BQDBZT	SOT-23	DBZ	3	250	180.0	8.4	2.9	3.35	1.35	4.0	8.0	Q3
TL431BQDBZT	SOT-23	DBZ	3	250	180.0	8.4	3.2	2.85	1.3	4.0	8.0	Q3
TL431BQDBZTG4	SOT-23	DBZ	3	250	180.0	8.4	2.9	3.35	1.35	4.0	8.0	Q3
TL431BQDCKR	SC70	DCK	6	3000	180.0	8.4	2.3	2.5	1.2	4.0	8.0	Q3
TL431BQDCKR	SC70	DCK	6	3000	179.0	8.4	2.2	2.5	1.2	4.0	8.0	Q3
TL431BQDCKT	SC70	DCK	6	250	179.0	8.4	2.2	2.5	1.2	4.0	8.0	Q3
TL431BQDCKT	SC70	DCK	6	250	180.0	8.4	2.3	2.5	1.2	4.0	8.0	Q3
TL431BQDR	SOIC	D	8	2500	330.0	12.4	6.4	5.2	2.1	8.0	12.0	Q1
TL431BQDR	SOIC	D	8	2500	330.0	12.4	6.4	5.2	2.1	8.0	12.0	Q1
TL431BQPK	SOT-89	PK	3	1000	180.0	12.4	4.91	4.52	1.9	8.0	12.0	Q3
TL431CDBVR	SOT-23	DBV	5	3000	178.0	8.4	3.2	3.2	1.4	4.0	8.0	Q3
TL431CDBVT	SOT-23	DBV	5	250	180.0	8.4	3.2	3.2	1.4	4.0	8.0	Q3
TL431CDBZR	SOT-23	DBZ	3	3000	180.0	8.4	2.9	3.35	1.35	4.0	8.0	Q3
TL431CDBZRG4	SOT-23	DBZ	3	3000	180.0	8.4	2.9	3.35	1.35	4.0	8.0	Q3
TL431CDBZT	SOT-23	DBZ	3	250	180.0	8.4	2.9	3.35	1.35	4.0	8.0	Q3
TL431CDBZT	SOT-23	DBZ	3	250	180.0	8.4	3.2	2.85	1.3	4.0	8.0	Q3
TL431CDBZTG4	SOT-23	DBZ	3	250	180.0	8.4	2.9	3.35	1.35	4.0	8.0	Q3
TL431CDR	SOIC	D	8	2500	330.0	12.4	6.4	5.2	2.1	8.0	12.0	Q1

Device	Package Type	Package Drawing	Pins	SPQ	Reel Diameter (mm)	Reel Width W1 (mm)	A0 (mm)	B0 (mm)	K0 (mm)	P1 (mm)	W (mm)	Pin1 Quadrant
TL431CDR-J	SOIC	D	8	2500	330.0	12.4	6.4	5.2	2.1	8.0	12.0	Q1
TL431CPK	SOT-89	PK	3	1000	180.0	12.4	4.91	4.52	1.9	8.0	12.0	Q3
TL431CPK	SOT-89	PK	3	1000	180.0	12.4	4.91	4.52	1.9	8.0	12.0	Q3
TL431CPKE6	SOT-89	PK	3	1000	180.0	13.0	4.91	4.52	1.9	8.0	12.0	Q3
TL431IDBVR	SOT-23	DBV	5	3000	180.0	8.4	3.2	3.2	1.4	4.0	8.0	Q3
TL431IDBVT	SOT-23	DBV	5	250	180.0	8.4	3.2	3.2	1.4	4.0	8.0	Q3
TL431IDBZR	SOT-23	DBZ	3	3000	180.0	8.4	2.9	3.35	1.35	4.0	8.0	Q3
TL431IDBZRG4	SOT-23	DBZ	3	3000	180.0	8.4	2.9	3.35	1.35	4.0	8.0	Q3
TL431IDBZT	SOT-23	DBZ	3	250	180.0	8.4	3.2	2.85	1.3	4.0	8.0	Q3
TL431IDBZT	SOT-23	DBZ	3	250	180.0	8.4	2.9	3.35	1.35	4.0	8.0	Q3
TL431IDBZTG4	SOT-23	DBZ	3	250	180.0	8.4	2.9	3.35	1.35	4.0	8.0	Q3
TL431IDR	SOIC	D	8	2500	330.0	12.4	6.4	5.2	2.1	8.0	12.0	Q1
TL431IPK	SOT-89	PK	3	1000	180.0	12.4	4.91	4.52	1.9	8.0	12.0	Q3
TL431IPK	SOT-89	PK	3	1000	180.0	12.4	4.91	4.52	1.9	8.0	12.0	Q3
TL431QDBVR	SOT-23	DBV	5	3000	180.0	8.4	3.2	3.2	1.4	4.0	8.0	Q3
TL431QDBVT	SOT-23	DBV	5	250	180.0	8.4	3.2	3.2	1.4	4.0	8.0	Q3
TL431QDBZR	SOT-23	DBZ	3	3000	180.0	8.4	2.9	3.35	1.35	4.0	8.0	Q3
TL431QDBZRG4	SOT-23	DBZ	3	3000	180.0	8.4	2.9	3.35	1.35	4.0	8.0	Q3
TL431QDBZT	SOT-23	DBZ	3	250	180.0	8.4	3.2	2.85	1.3	4.0	8.0	Q3
TL431QDBZT	SOT-23	DBZ	3	250	180.0	8.4	2.9	3.35	1.35	4.0	8.0	Q3
TL431QDBZTG4	SOT-23	DBZ	3	250	180.0	8.4	2.9	3.35	1.35	4.0	8.0	Q3
TL431QDCKR	SC70	DCK	6	3000	179.0	8.4	2.2	2.5	1.2	4.0	8.0	Q3
TL431QDCKR	SC70	DCK	6	3000	180.0	8.4	2.3	2.5	1.2	4.0	8.0	Q3
TL431QDCKT	SC70	DCK	6	250	180.0	8.4	2.3	2.5	1.2	4.0	8.0	Q3
TL431QDCKT	SC70	DCK	6	250	179.0	8.4	2.2	2.5	1.2	4.0	8.0	Q3
TL431QDR	SOIC	D	8	2500	330.0	12.4	6.4	5.2	2.1	8.0	12.0	Q1
TL431QDR	SOIC	D	8	2500	330.0	12.4	6.4	5.2	2.1	8.0	12.0	Q1
TL431QPK	SOT-89	PK	3	1000	180.0	12.4	4.91	4.52	1.9	8.0	12.0	Q3
TL432ACDBVR	SOT-23	DBV	5	3000	180.0	8.4	3.2	3.2	1.4	4.0	8.0	Q3
TL432ACDBVR	SOT-23	DBV	5	3000	180.0	8.4	3.2	3.2	1.4	4.0	8.0	Q3
TL432ACDBZR	SOT-23	DBZ	3	3000	180.0	8.4	2.9	3.35	1.35	4.0	8.0	Q3
TL432ACDBZR	SOT-23	DBZ	3	3000	180.0	8.4	3.2	2.85	1.3	4.0	8.0	Q3
TL432ACDBZRG4	SOT-23	DBZ	3	3000	180.0	8.4	2.9	3.35	1.35	4.0	8.0	Q3
TL432ACDBZT	SOT-23	DBZ	3	250	180.0	8.4	3.2	2.85	1.3	4.0	8.0	Q3
TL432ACDBZT	SOT-23	DBZ	3	250	180.0	8.4	2.9	3.35	1.35	4.0	8.0	Q3
TL432ACDBZTG4	SOT-23	DBZ	3	250	180.0	8.4	2.9	3.35	1.35	4.0	8.0	Q3
TL432AIDBVR	SOT-23	DBV	5	3000	180.0	8.4	3.2	3.2	1.4	4.0	8.0	Q3
TL432AIDBVR	SOT-23	DBV	5	3000	180.0	8.4	3.2	3.2	1.4	4.0	8.0	Q3
TL432AIDBZR	SOT-23	DBZ	3	3000	180.0	8.4	2.9	3.35	1.35	4.0	8.0	Q3
TL432AIDBZRG4	SOT-23	DBZ	3	3000	180.0	8.4	2.9	3.35	1.35	4.0	8.0	Q3
TL432AIDBZT	SOT-23	DBZ	3	250	180.0	8.4	3.2	2.85	1.3	4.0	8.0	Q3

Device	Package Type	Package Drawing	Pins	SPQ	Reel Diameter (mm)	Reel Width W1 (mm)	A0 (mm)	B0 (mm)	K0 (mm)	P1 (mm)	W (mm)	Pin1 Quadrant
TL432AIDBZT	SOT-23	DBZ	3	250	180.0	8.4	2.9	3.35	1.35	4.0	8.0	Q3
TL432AIDBZTG4	SOT-23	DBZ	3	250	180.0	8.4	2.9	3.35	1.35	4.0	8.0	Q3
TL432AIPK	SOT-89	PK	3	1000	180.0	12.4	4.91	4.52	1.9	8.0	12.0	Q3
TL432AIPK	SOT-89	PK	3	1000	180.0	12.4	4.91	4.52	1.9	8.0	12.0	Q3
TL432AQDBVR	SOT-23	DBV	5	3000	180.0	8.4	3.2	3.2	1.4	4.0	8.0	Q3
TL432AQDBVR	SOT-23	DBV	5	3000	180.0	8.4	3.2	3.2	1.4	4.0	8.0	Q3
TL432AQDBVT	SOT-23	DBV	5	250	180.0	8.4	3.2	3.2	1.4	4.0	8.0	Q3
TL432AQDBVT	SOT-23	DBV	5	250	180.0	8.4	3.2	3.2	1.4	4.0	8.0	Q3
TL432AQDBZR	SOT-23	DBZ	3	3000	180.0	8.4	2.9	3.35	1.35	4.0	8.0	Q3
TL432AQDBZRG4	SOT-23	DBZ	3	3000	180.0	8.4	2.9	3.35	1.35	4.0	8.0	Q3
TL432AQDBZT	SOT-23	DBZ	3	250	180.0	8.4	3.2	2.85	1.3	4.0	8.0	Q3
TL432AQDBZT	SOT-23	DBZ	3	250	180.0	8.4	2.9	3.35	1.35	4.0	8.0	Q3
TL432AQDBZTG4	SOT-23	DBZ	3	250	180.0	8.4	2.9	3.35	1.35	4.0	8.0	Q3
TL432AQPCK	SOT-89	PK	3	1000	180.0	12.4	4.91	4.52	1.9	8.0	12.0	Q3
TL432AQPCK	SOT-89	PK	3	1000	180.0	12.4	4.91	4.52	1.9	8.0	12.0	Q3
TL432BCDBVR	SOT-23	DBV	5	3000	180.0	8.4	3.2	3.2	1.4	4.0	8.0	Q3
TL432BCDBVR	SOT-23	DBV	5	3000	180.0	8.4	3.2	3.2	1.4	4.0	8.0	Q3
TL432BCDBZR	SOT-23	DBZ	3	3000	180.0	8.4	3.2	2.85	1.3	4.0	8.0	Q3
TL432BCDBZR	SOT-23	DBZ	3	3000	180.0	8.4	2.9	3.35	1.35	4.0	8.0	Q3
TL432BCDBZRG4	SOT-23	DBZ	3	3000	180.0	8.4	2.9	3.35	1.35	4.0	8.0	Q3
TL432BCDBZT	SOT-23	DBZ	3	250	180.0	8.4	2.9	3.35	1.35	4.0	8.0	Q3
TL432BCDBZT	SOT-23	DBZ	3	250	180.0	8.4	3.2	2.85	1.3	4.0	8.0	Q3
TL432BCDBZTG4	SOT-23	DBZ	3	250	180.0	8.4	2.9	3.35	1.35	4.0	8.0	Q3
TL432BCPK	SOT-89	PK	3	1000	180.0	12.4	4.91	4.52	1.9	8.0	12.0	Q3
TL432BCPK	SOT-89	PK	3	1000	180.0	12.4	4.91	4.52	1.9	8.0	12.0	Q3
TL432BIDBZR	SOT-23	DBZ	3	3000	180.0	8.4	2.9	3.35	1.35	4.0	8.0	Q3
TL432BIDBZRG4	SOT-23	DBZ	3	3000	180.0	8.4	2.9	3.35	1.35	4.0	8.0	Q3
TL432BIDBZT	SOT-23	DBZ	3	250	180.0	8.4	2.9	3.35	1.35	4.0	8.0	Q3
TL432BIDBZT	SOT-23	DBZ	3	250	180.0	8.4	3.2	2.85	1.3	4.0	8.0	Q3
TL432BIDBZTG4	SOT-23	DBZ	3	250	180.0	8.4	2.9	3.35	1.35	4.0	8.0	Q3
TL432BIPK	SOT-89	PK	3	1000	180.0	12.4	4.91	4.52	1.9	8.0	12.0	Q3
TL432BIPK	SOT-89	PK	3	1000	180.0	12.4	4.91	4.52	1.9	8.0	12.0	Q3
TL432BQDBZR	SOT-23	DBZ	3	3000	180.0	8.4	2.9	3.35	1.35	4.0	8.0	Q3
TL432BQDBZR1G4	SOT-23	DBZ	3	3000	180.0	8.4	2.9	3.35	1.35	4.0	8.0	Q3
TL432BQPK	SOT-89	PK	3	1000	180.0	12.4	4.91	4.52	1.9	8.0	12.0	Q3
TL432BQPK	SOT-89	PK	3	1000	180.0	12.4	4.91	4.52	1.9	8.0	12.0	Q3
TL432CDBVR	SOT-23	DBV	5	3000	180.0	8.4	3.2	3.2	1.4	4.0	8.0	Q3
TL432CDBVR	SOT-23	DBV	5	3000	180.0	8.4	3.2	3.2	1.4	4.0	8.0	Q3
TL432CDBZR	SOT-23	DBZ	3	3000	180.0	8.4	2.9	3.35	1.35	4.0	8.0	Q3
TL432CDBZRG4	SOT-23	DBZ	3	3000	180.0	8.4	2.9	3.35	1.35	4.0	8.0	Q3
TL432CPK	SOT-89	PK	3	1000	180.0	12.4	4.91	4.52	1.9	8.0	12.0	Q3

Device	Package Type	Package Drawing	Pins	SPQ	Reel Diameter (mm)	Reel Width W1 (mm)	A0 (mm)	B0 (mm)	K0 (mm)	P1 (mm)	W (mm)	Pin1 Quadrant
TL432CPK	SOT-89	PK	3	1000	180.0	12.4	4.91	4.52	1.9	8.0	12.0	Q3
TL432IDBVR	SOT-23	DBV	5	3000	180.0	8.4	3.2	3.2	1.4	4.0	8.0	Q3
TL432IDBVR	SOT-23	DBV	5	3000	180.0	8.4	3.2	3.2	1.4	4.0	8.0	Q3
TL432IDBZR	SOT-23	DBZ	3	3000	180.0	8.4	3.2	2.85	1.3	4.0	8.0	Q3
TL432IDBZR	SOT-23	DBZ	3	3000	180.0	8.4	2.9	3.35	1.35	4.0	8.0	Q3
TL432IDBZRG4	SOT-23	DBZ	3	3000	180.0	8.4	2.9	3.35	1.35	4.0	8.0	Q3
TL432IDBZT	SOT-23	DBZ	3	250	180.0	8.4	3.2	2.85	1.3	4.0	8.0	Q3
TL432IDBZT	SOT-23	DBZ	3	250	180.0	8.4	2.9	3.35	1.35	4.0	8.0	Q3
TL432IDBZTG4	SOT-23	DBZ	3	250	180.0	8.4	2.9	3.35	1.35	4.0	8.0	Q3
TL432IPK	SOT-89	PK	3	1000	180.0	12.4	4.91	4.52	1.9	8.0	12.0	Q3
TL432IPK	SOT-89	PK	3	1000	180.0	12.4	4.91	4.52	1.9	8.0	12.0	Q3
TL432QDBZR	SOT-23	DBZ	3	3000	180.0	8.4	3.2	2.85	1.3	4.0	8.0	Q3
TL432QDBZR	SOT-23	DBZ	3	3000	180.0	8.4	2.9	3.35	1.35	4.0	8.0	Q3
TL432QDBZRG4	SOT-23	DBZ	3	3000	180.0	8.4	2.9	3.35	1.35	4.0	8.0	Q3
TL432QPK	SOT-89	PK	3	1000	180.0	12.4	4.91	4.52	1.9	8.0	12.0	Q3
TL432QPK	SOT-89	PK	3	1000	180.0	12.4	4.91	4.52	1.9	8.0	12.0	Q3

TAPE AND REEL BOX DIMENSIONS

*All dimensions are nominal

Device	Package Type	Package Drawing	Pins	SPQ	Length (mm)	Width (mm)	Height (mm)
TL431ACDBVR	SOT-23	DBV	5	3000	210.0	185.0	35.0
TL431ACDBVT	SOT-23	DBV	5	250	210.0	185.0	35.0
TL431ACDBVT	SOT-23	DBV	5	250	210.0	185.0	35.0
TL431ACDBZR	SOT-23	DBZ	3	3000	210.0	185.0	35.0
TL431ACDBZRG4	SOT-23	DBZ	3	3000	210.0	185.0	35.0
TL431ACDBZT	SOT-23	DBZ	3	250	210.0	185.0	35.0
TL431ACDBZT	SOT-23	DBZ	3	250	210.0	185.0	35.0
TL431ACDBZTG4	SOT-23	DBZ	3	250	210.0	185.0	35.0
TL431ACDCKR	SC70	DCK	6	3000	183.0	183.0	20.0
TL431ACDCKR	SC70	DCK	6	3000	210.0	185.0	35.0
TL431ACDR	SOIC	D	8	2500	340.5	336.1	25.0
TL431ACPK	SOT-89	PK	3	1000	340.0	340.0	38.0
TL431ACPK	SOT-89	PK	3	1000	190.0	190.0	30.0
TL431ACPSR	SO	PS	8	2000	353.0	353.0	32.0
TL431ACPWR	TSSOP	PW	8	2000	353.0	353.0	32.0
TL431AIDBVR	SOT-23	DBV	5	3000	210.0	185.0	35.0
TL431AIDBVT	SOT-23	DBV	5	250	210.0	185.0	35.0
TL431AIDBVT	SOT-23	DBV	5	250	210.0	185.0	35.0

Device	Package Type	Package Drawing	Pins	SPQ	Length (mm)	Width (mm)	Height (mm)
TL431AIDBZR	SOT-23	DBZ	3	3000	210.0	185.0	35.0
TL431AIDBZRG4	SOT-23	DBZ	3	3000	210.0	185.0	35.0
TL431AIDBZT	SOT-23	DBZ	3	250	210.0	185.0	35.0
TL431AIDBZT	SOT-23	DBZ	3	250	210.0	185.0	35.0
TL431AIDBZTG4	SOT-23	DBZ	3	250	210.0	185.0	35.0
TL431AIDCKR	SC70	DCK	6	3000	200.0	183.0	25.0
TL431AIDCKR	SC70	DCK	6	3000	210.0	185.0	35.0
TL431AIDCKRG4	SC70	DCK	6	3000	200.0	183.0	25.0
TL431AIDCKT	SC70	DCK	6	250	210.0	185.0	35.0
TL431AIDCKT	SC70	DCK	6	250	200.0	183.0	25.0
TL431AIDR	SOIC	D	8	2500	353.0	353.0	32.0
TL431AIPK	SOT-89	PK	3	1000	190.0	190.0	30.0
TL431AIPK	SOT-89	PK	3	1000	340.0	340.0	38.0
TL431AQDBVR	SOT-23	DBV	5	3000	210.0	185.0	35.0
TL431AQDBVT	SOT-23	DBV	5	250	210.0	185.0	35.0
TL431AQDBZR	SOT-23	DBZ	3	3000	210.0	185.0	35.0
TL431AQDBZRG4	SOT-23	DBZ	3	3000	210.0	185.0	35.0
TL431AQDBZT	SOT-23	DBZ	3	250	210.0	185.0	35.0
TL431AQDBZT	SOT-23	DBZ	3	250	210.0	185.0	35.0
TL431AQDBZTG4	SOT-23	DBZ	3	250	210.0	185.0	35.0
TL431AQDCKR	SC70	DCK	6	3000	200.0	183.0	25.0
TL431AQDCKR	SC70	DCK	6	3000	210.0	185.0	35.0
TL431AQDCKT	SC70	DCK	6	250	200.0	183.0	25.0
TL431AQDCKT	SC70	DCK	6	250	210.0	185.0	35.0
TL431AQPK	SOT-89	PK	3	1000	190.0	190.0	30.0
TL431AQPK	SOT-89	PK	3	1000	340.0	340.0	38.0
TL431BCDBVR	SOT-23	DBV	5	3000	210.0	185.0	35.0
TL431BCDBVT	SOT-23	DBV	5	250	210.0	185.0	35.0
TL431BCDBVT	SOT-23	DBV	5	250	210.0	185.0	35.0
TL431BCDBZR	SOT-23	DBZ	3	3000	210.0	185.0	35.0
TL431BCDBZRG4	SOT-23	DBZ	3	3000	210.0	185.0	35.0
TL431BCDBZT	SOT-23	DBZ	3	250	210.0	185.0	35.0
TL431BCDBZT	SOT-23	DBZ	3	250	210.0	185.0	35.0
TL431BCDBZTG4	SOT-23	DBZ	3	250	210.0	185.0	35.0
TL431BCDCKR	SC70	DCK	6	3000	210.0	185.0	35.0
TL431BCDCKR	SC70	DCK	6	3000	200.0	183.0	25.0
TL431BCDCKT	SC70	DCK	6	250	200.0	183.0	25.0
TL431BCDCKT	SC70	DCK	6	250	210.0	185.0	35.0
TL431BCDR	SOIC	D	8	2500	353.0	353.0	32.0
TL431BCDR	SOIC	D	8	2500	353.0	353.0	32.0
TL431BCPK	SOT-89	PK	3	1000	340.0	340.0	38.0
TL431BCPK	SOT-89	PK	3	1000	190.0	190.0	30.0
TL431BIDBVR	SOT-23	DBV	5	3000	208.0	191.0	35.0

Device	Package Type	Package Drawing	Pins	SPQ	Length (mm)	Width (mm)	Height (mm)
TL431BIDBVT	SOT-23	DBV	5	250	210.0	185.0	35.0
TL431BIDBZR	SOT-23	DBZ	3	3000	210.0	185.0	35.0
TL431BIDBZRG4	SOT-23	DBZ	3	3000	210.0	185.0	35.0
TL431BIDBZT	SOT-23	DBZ	3	250	210.0	185.0	35.0
TL431BIDBZT	SOT-23	DBZ	3	250	210.0	185.0	35.0
TL431BIDBZTG4	SOT-23	DBZ	3	250	210.0	185.0	35.0
TL431BIDCKR	SC70	DCK	6	3000	200.0	183.0	25.0
TL431BIDCKR	SC70	DCK	6	3000	210.0	185.0	35.0
TL431BIDCKT	SC70	DCK	6	250	203.0	203.0	35.0
TL431BIDCKT	SC70	DCK	6	250	210.0	185.0	35.0
TL431BIDR	SOIC	D	8	2500	353.0	353.0	32.0
TL431BIDR	SOIC	D	8	2500	353.0	353.0	32.0
TL431BIPK	SOT-89	PK	3	1000	190.0	190.0	30.0
TL431BIPK	SOT-89	PK	3	1000	340.0	340.0	38.0
TL431BQDBVR	SOT-23	DBV	5	3000	210.0	185.0	35.0
TL431BQDBVT	SOT-23	DBV	5	250	210.0	185.0	35.0
TL431BQDBVT	SOT-23	DBV	5	250	210.0	185.0	35.0
TL431BQDBZR	SOT-23	DBZ	3	3000	210.0	185.0	35.0
TL431BQDBZRG4	SOT-23	DBZ	3	3000	210.0	185.0	35.0
TL431BQDBZT	SOT-23	DBZ	3	250	210.0	185.0	35.0
TL431BQDBZT	SOT-23	DBZ	3	250	210.0	185.0	35.0
TL431BQDBZTG4	SOT-23	DBZ	3	250	210.0	185.0	35.0
TL431BQDCKR	SC70	DCK	6	3000	210.0	185.0	35.0
TL431BQDCKR	SC70	DCK	6	3000	200.0	183.0	25.0
TL431BQDCKT	SC70	DCK	6	250	203.0	203.0	35.0
TL431BQDCKT	SC70	DCK	6	250	210.0	185.0	35.0
TL431BQDR	SOIC	D	8	2500	353.0	353.0	32.0
TL431BQDR	SOIC	D	8	2500	340.5	336.1	25.0
TL431BQPK	SOT-89	PK	3	1000	190.0	190.0	30.0
TL431CDBVR	SOT-23	DBV	5	3000	208.0	191.0	35.0
TL431CDBVT	SOT-23	DBV	5	250	210.0	185.0	35.0
TL431CDBZR	SOT-23	DBZ	3	3000	210.0	185.0	35.0
TL431CDBZRG4	SOT-23	DBZ	3	3000	210.0	185.0	35.0
TL431CDBZT	SOT-23	DBZ	3	250	210.0	185.0	35.0
TL431CDBZT	SOT-23	DBZ	3	250	210.0	185.0	35.0
TL431CDBZTG4	SOT-23	DBZ	3	250	210.0	185.0	35.0
TL431CDR	SOIC	D	8	2500	340.5	338.1	20.6
TL431CDR-J	SOIC	D	8	2500	340.5	338.1	20.6
TL431CPK	SOT-89	PK	3	1000	190.0	190.0	30.0
TL431CPK	SOT-89	PK	3	1000	340.0	340.0	38.0
TL431CPKE6	SOT-89	PK	3	1000	182.0	182.0	20.0
TL431IDBVR	SOT-23	DBV	5	3000	210.0	185.0	35.0
TL431IDBVT	SOT-23	DBV	5	250	210.0	185.0	35.0

Device	Package Type	Package Drawing	Pins	SPQ	Length (mm)	Width (mm)	Height (mm)
TL431IDBZR	SOT-23	DBZ	3	3000	210.0	185.0	35.0
TL431IDBZRG4	SOT-23	DBZ	3	3000	210.0	185.0	35.0
TL431IDBZT	SOT-23	DBZ	3	250	210.0	185.0	35.0
TL431IDBZT	SOT-23	DBZ	3	250	210.0	185.0	35.0
TL431IDBZTG4	SOT-23	DBZ	3	250	210.0	185.0	35.0
TL431IDR	SOIC	D	8	2500	353.0	353.0	32.0
TL431IPK	SOT-89	PK	3	1000	340.0	340.0	38.0
TL431IPK	SOT-89	PK	3	1000	190.0	190.0	30.0
TL431QDBVR	SOT-23	DBV	5	3000	210.0	185.0	35.0
TL431QDBVT	SOT-23	DBV	5	250	210.0	185.0	35.0
TL431QDBZR	SOT-23	DBZ	3	3000	210.0	185.0	35.0
TL431QDBZRG4	SOT-23	DBZ	3	3000	210.0	185.0	35.0
TL431QDBZT	SOT-23	DBZ	3	250	210.0	185.0	35.0
TL431QDBZT	SOT-23	DBZ	3	250	210.0	185.0	35.0
TL431QDBZTG4	SOT-23	DBZ	3	250	210.0	185.0	35.0
TL431QDCKR	SC70	DCK	6	3000	203.0	203.0	35.0
TL431QDCKR	SC70	DCK	6	3000	210.0	185.0	35.0
TL431QDCKT	SC70	DCK	6	250	210.0	185.0	35.0
TL431QDCKT	SC70	DCK	6	250	203.0	203.0	35.0
TL431QDR	SOIC	D	8	2500	353.0	353.0	32.0
TL431QDR	SOIC	D	8	2500	353.0	353.0	32.0
TL431QPK	SOT-89	PK	3	1000	190.0	190.0	30.0
TL432ACDBVR	SOT-23	DBV	5	3000	210.0	185.0	35.0
TL432ACDBVR	SOT-23	DBV	5	3000	210.0	185.0	35.0
TL432ACDBZR	SOT-23	DBZ	3	3000	210.0	185.0	35.0
TL432ACDBZR	SOT-23	DBZ	3	3000	210.0	185.0	35.0
TL432ACDBZRG4	SOT-23	DBZ	3	3000	210.0	185.0	35.0
TL432ACDBZT	SOT-23	DBZ	3	250	210.0	185.0	35.0
TL432ACDBZT	SOT-23	DBZ	3	250	210.0	185.0	35.0
TL432ACDBZTG4	SOT-23	DBZ	3	250	210.0	185.0	35.0
TL432AIDBVR	SOT-23	DBV	5	3000	210.0	185.0	35.0
TL432AIDBVR	SOT-23	DBV	5	3000	210.0	185.0	35.0
TL432AIDBZR	SOT-23	DBZ	3	3000	210.0	185.0	35.0
TL432AIDBZRG4	SOT-23	DBZ	3	3000	210.0	185.0	35.0
TL432AIDBZT	SOT-23	DBZ	3	250	210.0	185.0	35.0
TL432AIDBZT	SOT-23	DBZ	3	250	210.0	185.0	35.0
TL432AIDBZTG4	SOT-23	DBZ	3	250	210.0	185.0	35.0
TL432AIPK	SOT-89	PK	3	1000	340.0	340.0	38.0
TL432AIPK	SOT-89	PK	3	1000	190.0	190.0	30.0
TL432AQDBVR	SOT-23	DBV	5	3000	210.0	185.0	35.0
TL432AQDBVR	SOT-23	DBV	5	3000	210.0	185.0	35.0
TL432AQDBVT	SOT-23	DBV	5	250	210.0	185.0	35.0
TL432AQDBVT	SOT-23	DBV	5	250	210.0	185.0	35.0

Device	Package Type	Package Drawing	Pins	SPQ	Length (mm)	Width (mm)	Height (mm)
TL432AQDBZR	SOT-23	DBZ	3	3000	210.0	185.0	35.0
TL432AQDBZRG4	SOT-23	DBZ	3	3000	210.0	185.0	35.0
TL432AQDBZT	SOT-23	DBZ	3	250	210.0	185.0	35.0
TL432AQDBZT	SOT-23	DBZ	3	250	210.0	185.0	35.0
TL432AQDBZTG4	SOT-23	DBZ	3	250	210.0	185.0	35.0
TL432AQP	SOT-89	PK	3	1000	190.0	190.0	30.0
TL432AQP	SOT-89	PK	3	1000	340.0	340.0	38.0
TL432BCDBVR	SOT-23	DBV	5	3000	210.0	185.0	35.0
TL432BCDBVR	SOT-23	DBV	5	3000	210.0	185.0	35.0
TL432BCDBZR	SOT-23	DBZ	3	3000	210.0	185.0	35.0
TL432BCDBZR	SOT-23	DBZ	3	3000	210.0	185.0	35.0
TL432BCDBZRG4	SOT-23	DBZ	3	3000	210.0	185.0	35.0
TL432BCDBZT	SOT-23	DBZ	3	250	210.0	185.0	35.0
TL432BCDBZT	SOT-23	DBZ	3	250	210.0	185.0	35.0
TL432BCDBZTG4	SOT-23	DBZ	3	250	210.0	185.0	35.0
TL432BCPK	SOT-89	PK	3	1000	340.0	340.0	38.0
TL432BCPK	SOT-89	PK	3	1000	190.0	190.0	30.0
TL432BIDBZR	SOT-23	DBZ	3	3000	210.0	185.0	35.0
TL432BIDBZRG4	SOT-23	DBZ	3	3000	210.0	185.0	35.0
TL432BIDBZT	SOT-23	DBZ	3	250	210.0	185.0	35.0
TL432BIDBZT	SOT-23	DBZ	3	250	210.0	185.0	35.0
TL432BIDBZTG4	SOT-23	DBZ	3	250	210.0	185.0	35.0
TL432BIPK	SOT-89	PK	3	1000	190.0	190.0	30.0
TL432BIPK	SOT-89	PK	3	1000	340.0	340.0	38.0
TL432BQDBZR	SOT-23	DBZ	3	3000	210.0	185.0	35.0
TL432BQDBZRG4	SOT-23	DBZ	3	3000	210.0	185.0	35.0
TL432BQPK	SOT-89	PK	3	1000	340.0	340.0	38.0
TL432BQPK	SOT-89	PK	3	1000	190.0	190.0	30.0
TL432CDBVR	SOT-23	DBV	5	3000	210.0	185.0	35.0
TL432CDBVR	SOT-23	DBV	5	3000	210.0	185.0	35.0
TL432CDBZR	SOT-23	DBZ	3	3000	210.0	185.0	35.0
TL432CDBZRG4	SOT-23	DBZ	3	3000	210.0	185.0	35.0
TL432CPK	SOT-89	PK	3	1000	340.0	340.0	38.0
TL432CPK	SOT-89	PK	3	1000	190.0	190.0	30.0
TL432IDBVR	SOT-23	DBV	5	3000	210.0	185.0	35.0
TL432IDBVR	SOT-23	DBV	5	3000	210.0	185.0	35.0
TL432IDBZR	SOT-23	DBZ	3	3000	210.0	185.0	35.0
TL432IDBZR	SOT-23	DBZ	3	3000	210.0	185.0	35.0
TL432IDBZRG4	SOT-23	DBZ	3	3000	210.0	185.0	35.0
TL432IDBZT	SOT-23	DBZ	3	250	210.0	185.0	35.0
TL432IDBZT	SOT-23	DBZ	3	250	210.0	185.0	35.0
TL432IDBZTG4	SOT-23	DBZ	3	250	210.0	185.0	35.0
TL432IPK	SOT-89	PK	3	1000	340.0	340.0	38.0

Device	Package Type	Package Drawing	Pins	SPQ	Length (mm)	Width (mm)	Height (mm)
TL432IPK	SOT-89	PK	3	1000	190.0	190.0	30.0
TL432QDBZR	SOT-23	DBZ	3	3000	210.0	185.0	35.0
TL432QDBZR	SOT-23	DBZ	3	3000	210.0	185.0	35.0
TL432QDBZRG4	SOT-23	DBZ	3	3000	210.0	185.0	35.0
TL432QPK	SOT-89	PK	3	1000	340.0	340.0	38.0
TL432QPK	SOT-89	PK	3	1000	190.0	190.0	30.0

TUBE

*All dimensions are nominal

Device	Package Name	Package Type	Pins	SPQ	L (mm)	W (mm)	T (μm)	B (mm)
TL431ACD	D	SOIC	8	75	507	8	3940	4.32
TL431ACD.A	D	SOIC	8	75	507	8	3940	4.32
TL431ACP	P	PDIP	8	50	506	13.97	11230	4.32
TL431ACP.A	P	PDIP	8	50	506	13.97	11230	4.32
TL431AID	D	SOIC	8	75	507	8	3940	4.32
TL431AID.A	D	SOIC	8	75	507	8	3940	4.32
TL431BCD	D	SOIC	8	75	507	8	3940	4.32
TL431BCD.A	D	SOIC	8	75	507	8	3940	4.32
TL431BID	D	SOIC	8	75	507	8	3940	4.32
TL431BID.A	D	SOIC	8	75	507	8	3940	4.32
TL431BQD	D	SOIC	8	75	507	8	3940	4.32
TL431BQD.A	D	SOIC	8	75	507	8	3940	4.32
TL431CD	D	SOIC	8	75	507	8	3940	4.32
TL431CD.A	D	SOIC	8	75	507	8	3940	4.32
TL431ID	D	SOIC	8	75	507	8	3940	4.32
TL431ID.A	D	SOIC	8	75	507	8	3940	4.32
TL431QD	D	SOIC	8	75	507	8	3940	4.32
TL431QD.A	D	SOIC	8	75	507	8	3940	4.32

DBV0005A



PACKAGE OUTLINE

SOT-23 - 1.45 mm max height

SMALL OUTLINE TRANSISTOR

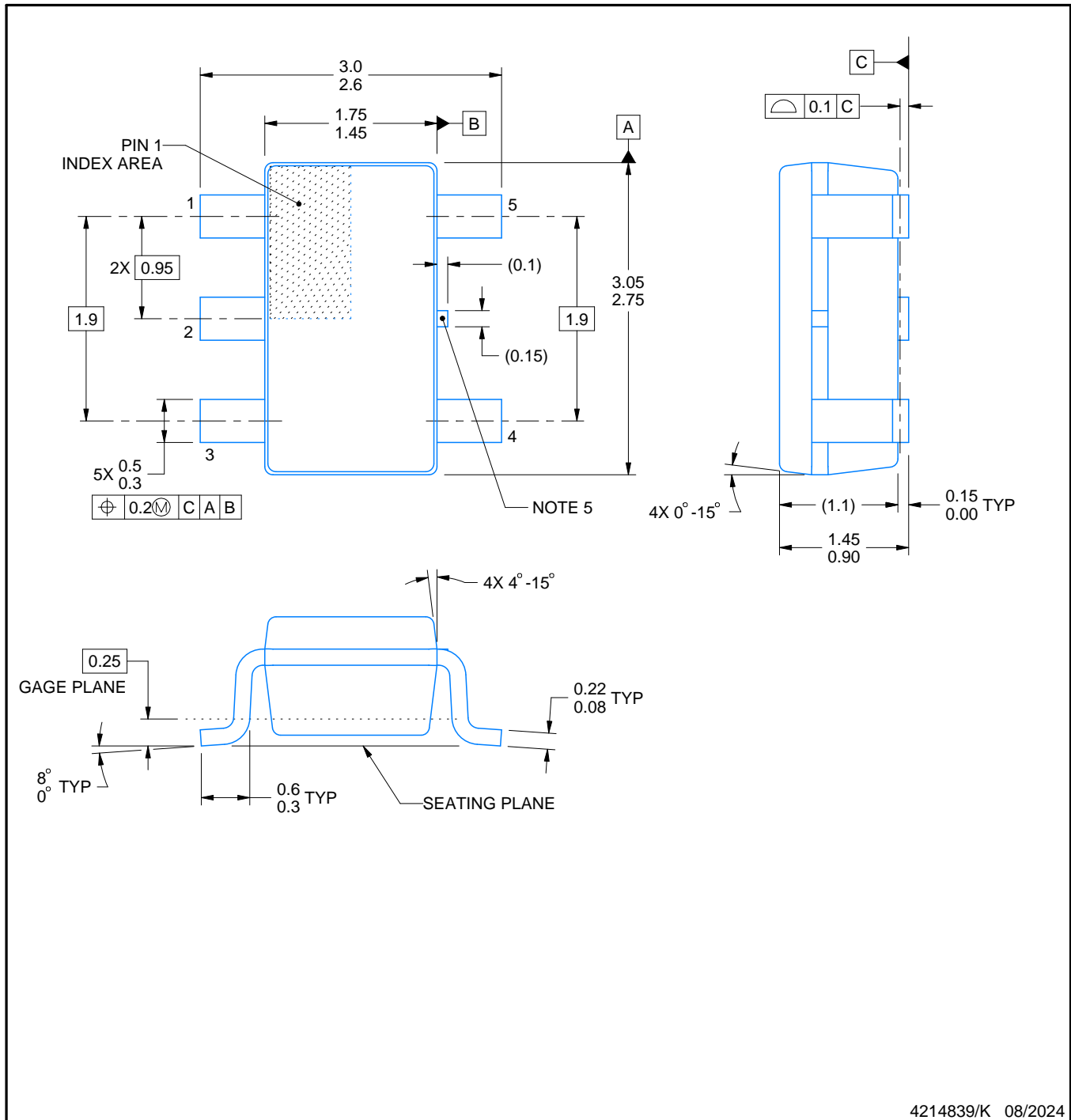

NOTES:

1. All linear dimensions are in millimeters. Any dimensions in parenthesis are for reference only. Dimensioning and tolerancing per ASME Y14.5M.
2. This drawing is subject to change without notice.
3. Reference JEDEC MO-178.
4. Body dimensions do not include mold flash, protrusions, or gate burrs. Mold flash, protrusions, or gate burrs shall not exceed 0.25 mm per side.
5. Support pin may differ or may not be present.

EXAMPLE BOARD LAYOUT

DBV0005A

SOT-23 - 1.45 mm max height

SMALL OUTLINE TRANSISTOR



LAND PATTERN EXAMPLE
EXPOSED METAL SHOWN
SCALE:15X



SOLDER MASK DETAILS

4214839/K 08/2024

NOTES: (continued)

- 6. Publication IPC-7351 may have alternate designs.
- 7. Solder mask tolerances between and around signal pads can vary based on board fabrication site.

EXAMPLE STENCIL DESIGN

DBV0005A

SOT-23 - 1.45 mm max height

SMALL OUTLINE TRANSISTOR



SOLDER PASTE EXAMPLE
BASED ON 0.125 mm THICK STENCIL
SCALE:15X

4214839/K 08/2024

NOTES: (continued)

8. Laser cutting apertures with trapezoidal walls and rounded corners may offer better paste release. IPC-7525 may have alternate design recommendations.
9. Board assembly site may have different recommendations for stencil design.

DCK0006A



PACKAGE OUTLINE

SOT - 1.1 max height

SMALL OUTLINE TRANSISTOR

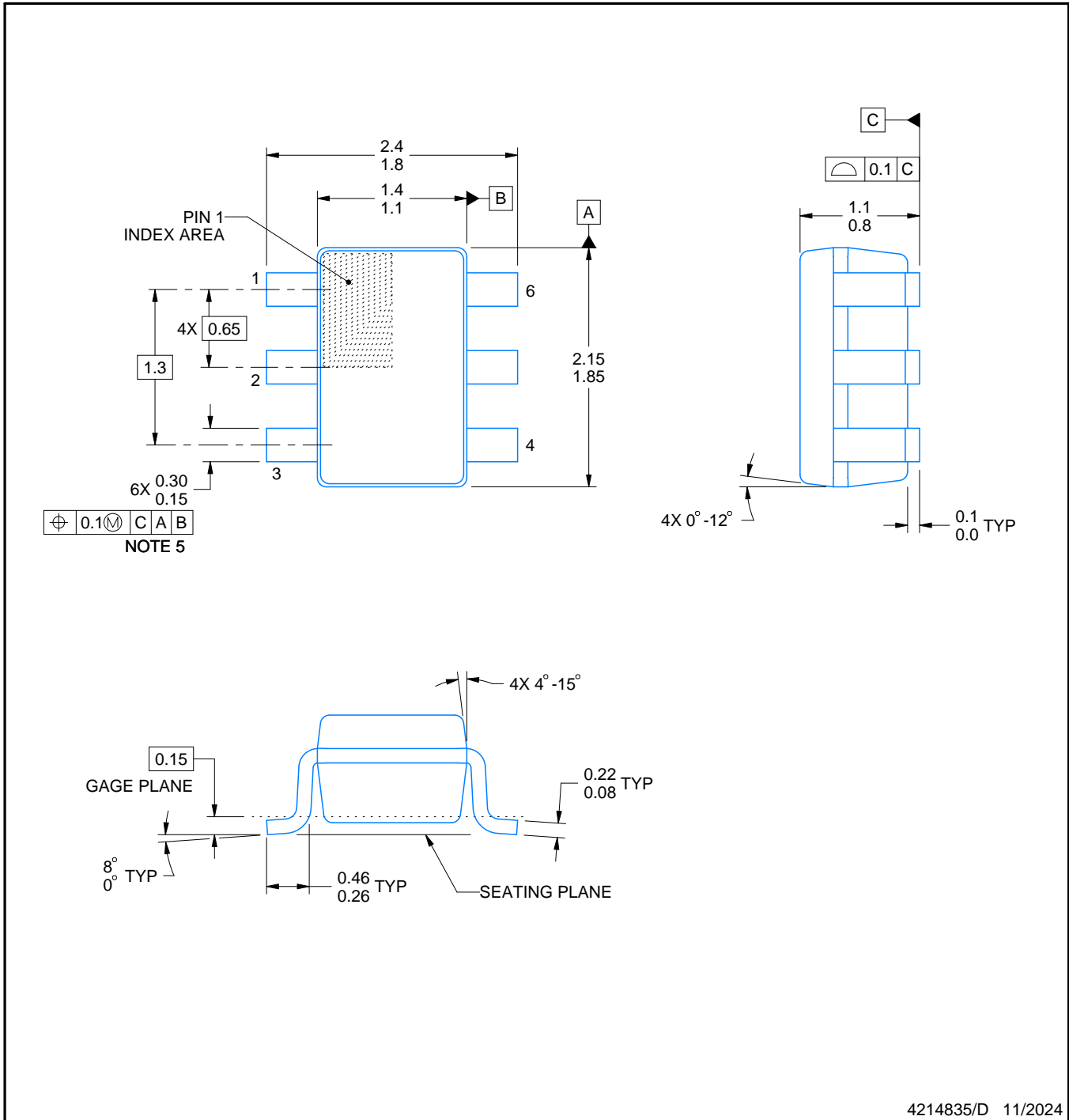

4214835/D 11/2024

NOTES:

1. All linear dimensions are in millimeters. Any dimensions in parenthesis are for reference only. Dimensioning and tolerancing per ASME Y14.5M.
2. This drawing is subject to change without notice.
3. Body dimensions do not include mold flash or protrusion. Mold flash and protrusion shall not exceed 0.15 per side.
4. Falls within JEDEC MO-203 variation AB.

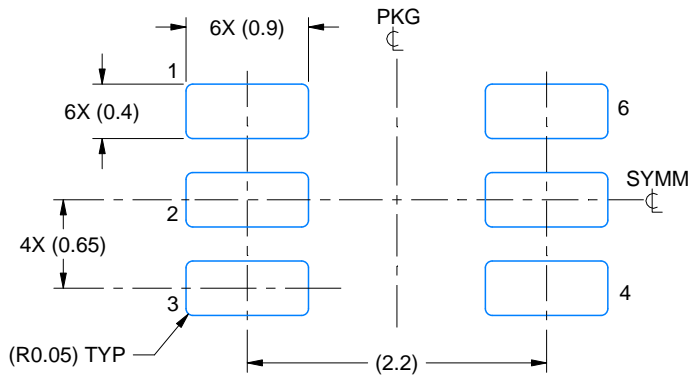

LAND PATTERN EXAMPLE
EXPOSED METAL SHOWN
SCALE:18X

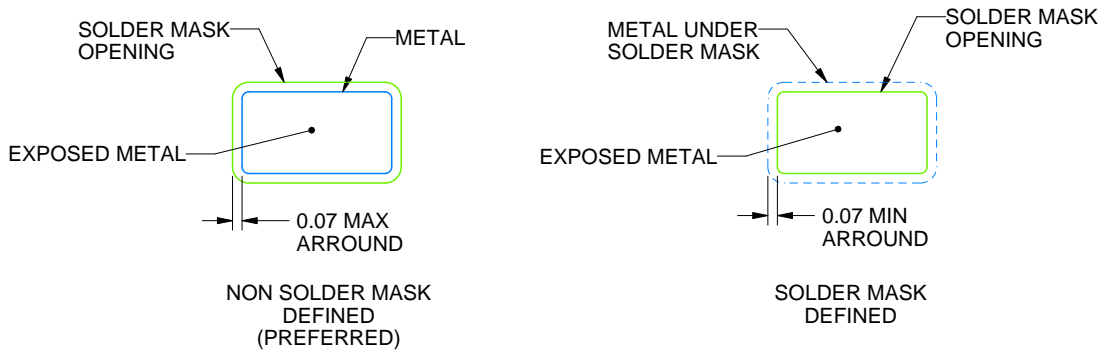

SOLDER MASK DETAILS

4214835/D 11/2024

NOTES: (continued)

- 5. Publication IPC-7351 may have alternate designs.
- 6. Solder mask tolerances between and around signal pads can vary based on board fabrication site.



SOLDER PASTE EXAMPLE
BASED ON 0.125 THICK STENCIL
SCALE:18X

4214835/D 11/2024

NOTES: (continued)

7. Laser cutting apertures with trapezoidal walls and rounded corners may offer better paste release. IPC-7525 may have alternate design recommendations.
8. Board assembly site may have different recommendations for stencil design.

DBZ0003A

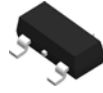

PACKAGE OUTLINE

SOT-23 - 1.12 mm max height

SMALL OUTLINE TRANSISTOR



4214838/F 08/2024

NOTES:

1. All linear dimensions are in millimeters. Any dimensions in parenthesis are for reference only. Dimensioning and tolerancing per ASME Y14.5M.
2. This drawing is subject to change without notice.
3. Reference JEDEC registration TO-236, except minimum foot length.
4. Support pin may differ or may not be present.
5. Body dimensions do not include mold flash, protrusions, or gate burrs. Mold flash, protrusions, or gate burrs shall not exceed 0.25mm per side

EXAMPLE BOARD LAYOUT

DBZ0003A

SOT-23 - 1.12 mm max height

SMALL OUTLINE TRANSISTOR



LAND PATTERN EXAMPLE
SCALE:15X

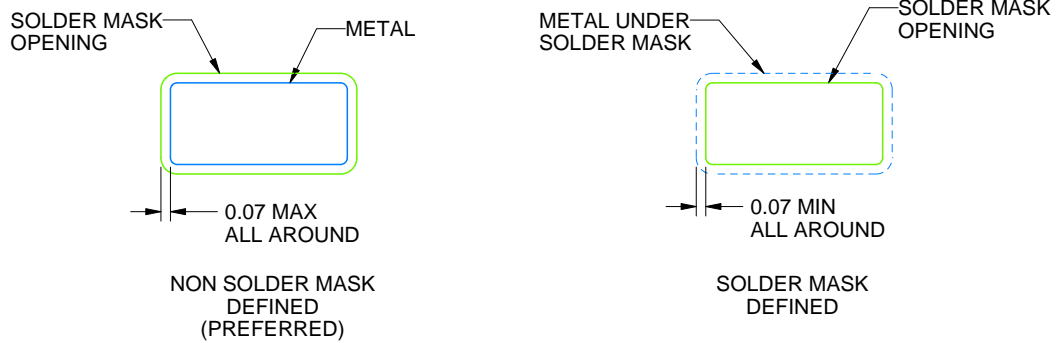

SOLDER MASK DETAILS

4214838/F 08/2024

NOTES: (continued)

- 5. Publication IPC-7351 may have alternate designs.
- 6. Solder mask tolerances between and around signal pads can vary based on board fabrication site.

EXAMPLE STENCIL DESIGN

DBZ0003A

SOT-23 - 1.12 mm max height

SMALL OUTLINE TRANSISTOR



SOLDER PASTE EXAMPLE
BASED ON 0.125 THICK STENCIL
SCALE:15X

4214838/F 08/2024

NOTES: (continued)

7. Laser cutting apertures with trapezoidal walls and rounded corners may offer better paste release. IPC-7525 may have alternate design recommendations.
8. Board assembly site may have different recommendations for stencil design.

PK (R-PSS0-F3)

PLASTIC SINGLE-IN-LINE PACKAGE



- NOTES:
- All linear dimensions are in millimeters. Dimensioning and tolerancing per ASME Y14.5M-1994.
 - This drawing is subject to change without notice.
 - The center lead is in electrical contact with the tab.
 - Body dimensions do not include mold flash or protrusion. Mold flash and protrusion not to exceed 0.15 per side.
- △E Thermal pad contour optional within these dimensions.
- △F Falls within JEDEC TO-243 variation AA, except minimum lead length, pin 2 minimum lead width, minimum tab width.

PK (R-PDSO-G3)



4208221/A 09/06

- NOTES:
- A. All linear dimensions are in millimeters.
 - B. This drawing is subject to change without notice.
 - C. Publication IPC-7351 is recommended for alternate designs.
 - D. Laser cutting apertures with trapezoidal walls and also rounding corners will offer better paste release. Customers should contact their board assembly site for stencil design recommendations. Refer to IPC-7525.
 - E. Customers should contact their board fabrication site for solder mask tolerances between and around signal pads.



D0008A

PACKAGE OUTLINE

SOIC - 1.75 mm max height

SMALL OUTLINE INTEGRATED CIRCUIT



4214825/C 02/2019

NOTES:

1. Linear dimensions are in inches [millimeters]. Dimensions in parenthesis are for reference only. Controlling dimensions are in inches. Dimensioning and tolerancing per ASME Y14.5M.
2. This drawing is subject to change without notice.
3. This dimension does not include mold flash, protrusions, or gate burrs. Mold flash, protrusions, or gate burrs shall not exceed $.006$ [0.15] per side.
4. This dimension does not include interlead flash.
5. Reference JEDEC registration MS-012, variation AA.

EXAMPLE BOARD LAYOUT

D0008A

SOIC - 1.75 mm max height

SMALL OUTLINE INTEGRATED CIRCUIT



LAND PATTERN EXAMPLE
 EXPOSED METAL SHOWN
 SCALE:8X



SOLDER MASK DETAILS

4214825/C 02/2019

NOTES: (continued)

- 6. Publication IPC-7351 may have alternate designs.
- 7. Solder mask tolerances between and around signal pads can vary based on board fabrication site.

EXAMPLE STENCIL DESIGN

D0008A

SOIC - 1.75 mm max height

SMALL OUTLINE INTEGRATED CIRCUIT



SOLDER PASTE EXAMPLE
BASED ON .005 INCH [0.125 MM] THICK STENCIL
SCALE:8X

4214825/C 02/2019

NOTES: (continued)

8. Laser cutting apertures with trapezoidal walls and rounded corners may offer better paste release. IPC-7525 may have alternate design recommendations.
9. Board assembly site may have different recommendations for stencil design.

MECHANICAL DATA

PS (R-PDSO-G8)

PLASTIC SMALL-OUTLINE PACKAGE



- NOTES:
- A. All linear dimensions are in millimeters.
 - B. This drawing is subject to change without notice.
 - C. Body dimensions do not include mold flash or protrusion, not to exceed 0,15.

PS (R-PDSO-G8)

PLASTIC SMALL OUTLINE



- NOTES:
- All linear dimensions are in millimeters.
 - This drawing is subject to change without notice.
 - Publication IPC-7351 is recommended for alternate designs.
 - Laser cutting apertures with trapezoidal walls and also rounding corners will offer better paste release. Customers should contact their board assembly site for stencil design recommendations. Refer to IPC-7525 for other stencil recommendations.
 - Customers should contact their board fabrication site for solder mask tolerances between and around signal pads.

LP0003A



PACKAGE OUTLINE

TO-92 - 5.34 mm max height

TO-92

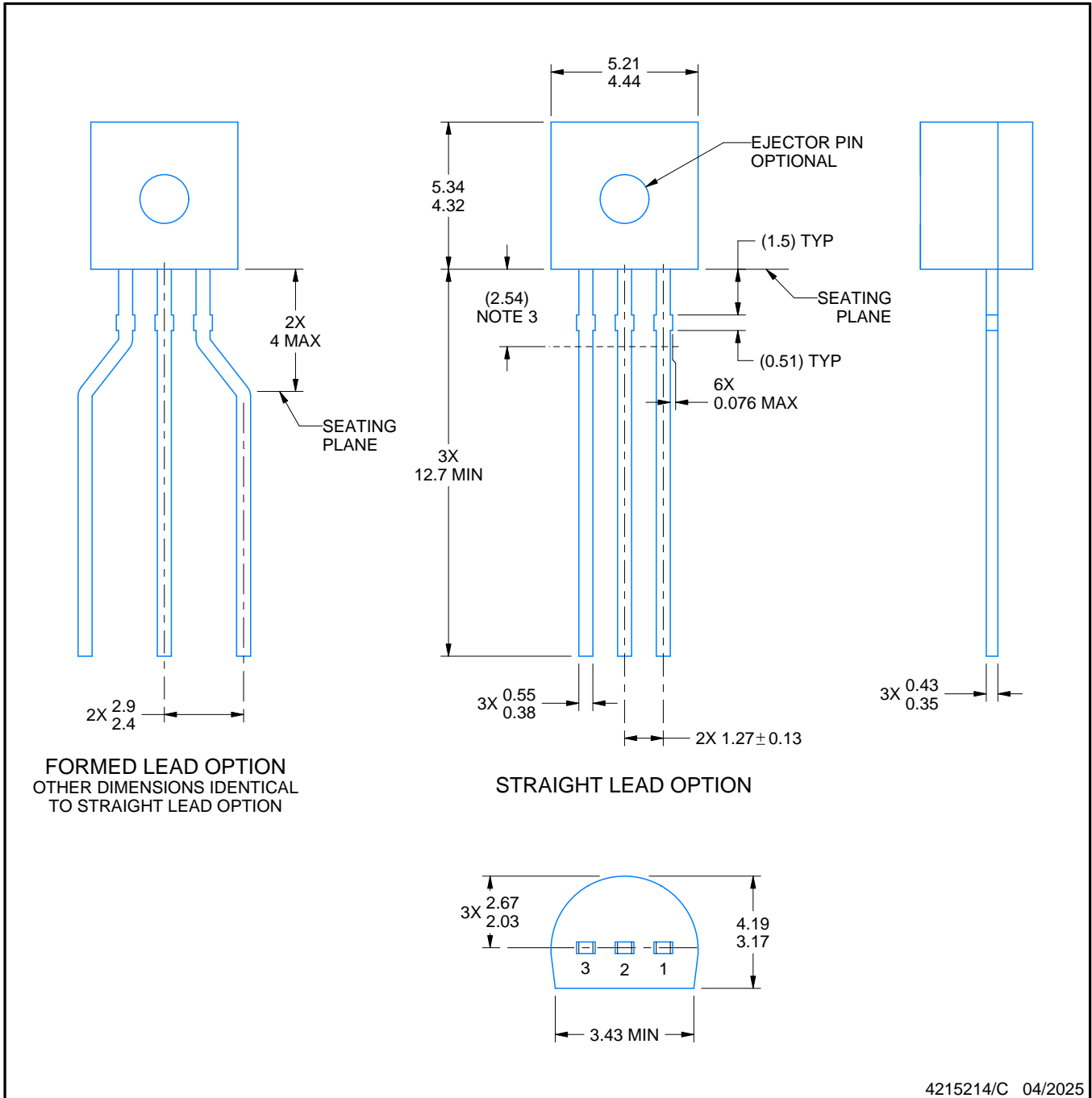

4215214/C 04/2025

NOTES:

1. All linear dimensions are in millimeters. Any dimensions in parenthesis are for reference only. Dimensioning and tolerancing per ASME Y14.5M.
2. This drawing is subject to change without notice.
3. Lead dimensions are not controlled within this area.
4. Reference JEDEC TO-226, variation AA.
5. Shipping method:
 - a. Straight lead option available in bulk pack only.
 - b. Formed lead option available in tape and reel or ammo pack.
 - c. Specific products can be offered in limited combinations of shipping medium and lead options.
 - d. Consult product folder for more information on available options.

EXAMPLE BOARD LAYOUT

LP0003A

TO-92 - 5.34 mm max height

TO-92

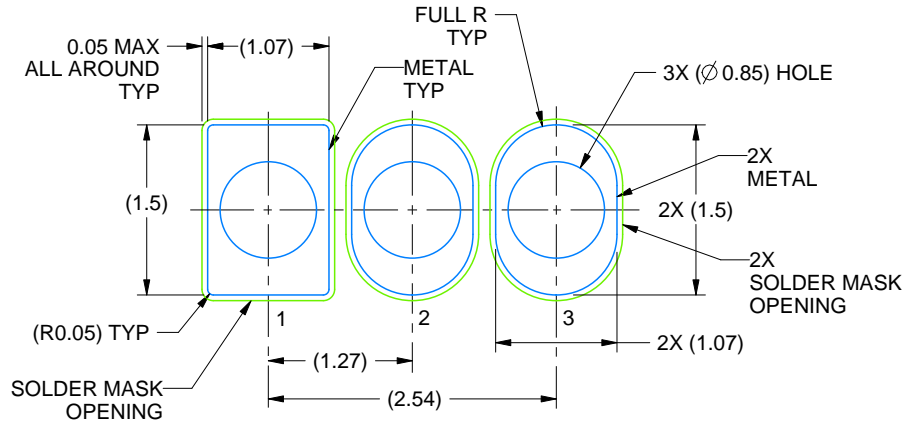

LAND PATTERN EXAMPLE
STRAIGHT LEAD OPTION
NON-SOLDER MASK DEFINED
SCALE:15X

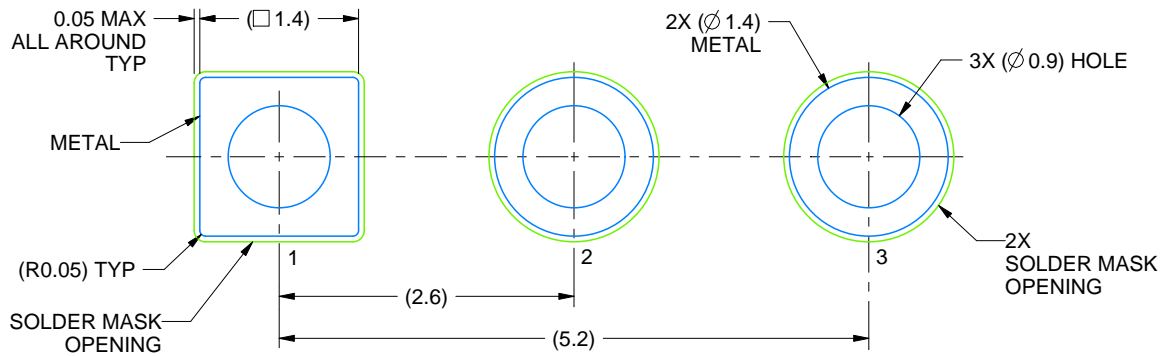

LAND PATTERN EXAMPLE
FORMED LEAD OPTION
NON-SOLDER MASK DEFINED
SCALE:15X

4215214/C 04/2025

TAPE SPECIFICATIONS

LP0003A

TO-92 - 5.34 mm max height

TO-92

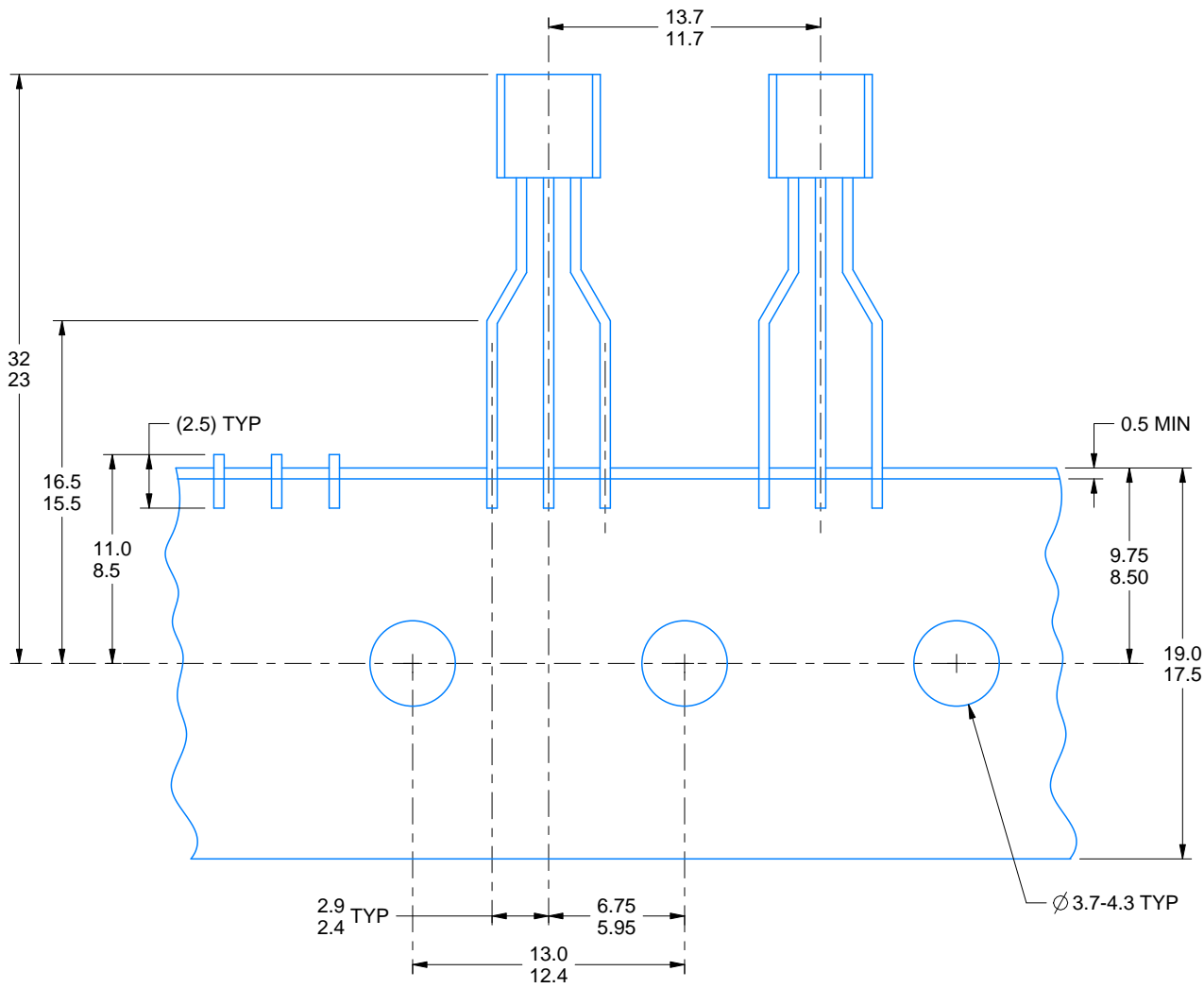

FOR FORMED LEAD OPTION PACKAGE

4215214/C 04/2025

P (R-PDIP-T8)

PLASTIC DUAL-IN-LINE PACKAGE



4040082/E 04/2010

- NOTES:
- A. All linear dimensions are in inches (millimeters).
 - B. This drawing is subject to change without notice.
 - C. Falls within JEDEC MS-001 variation BA.

PW0008A



PACKAGE OUTLINE
TSSOP - 1.2 mm max height

SMALL OUTLINE PACKAGE



4221848/A 02/2015

NOTES:

1. All linear dimensions are in millimeters. Any dimensions in parenthesis are for reference only. Dimensioning and tolerancing per ASME Y14.5M.
2. This drawing is subject to change without notice.
3. This dimension does not include mold flash, protrusions, or gate burrs. Mold flash, protrusions, or gate burrs shall not exceed 0.15 mm per side.
4. This dimension does not include interlead flash. Interlead flash shall not exceed 0.25 mm per side.
5. Reference JEDEC registration MO-153, variation AA.

EXAMPLE BOARD LAYOUT

PW0008A

TSSOP - 1.2 mm max height

SMALL OUTLINE PACKAGE



LAND PATTERN EXAMPLE
SCALE:10X



SOLDER MASK DETAILS
NOT TO SCALE

4221848/A 02/2015

NOTES: (continued)

- 6. Publication IPC-7351 may have alternate designs.
- 7. Solder mask tolerances between and around signal pads can vary based on board fabrication site.

EXAMPLE STENCIL DESIGN

PW0008A

TSSOP - 1.2 mm max height

SMALL OUTLINE PACKAGE



SOLDER PASTE EXAMPLE
BASED ON 0.125 mm THICK STENCIL
SCALE:10X

4221848/A 02/2015

NOTES: (continued)

8. Laser cutting apertures with trapezoidal walls and rounded corners may offer better paste release. IPC-7525 may have alternate design recommendations.
9. Board assembly site may have different recommendations for stencil design.

重要通知和免责声明

TI“按原样”提供技术和可靠性数据（包括数据表）、设计资源（包括参考设计）、应用或其他设计建议、网络工具、安全信息和其他资源，不保证没有瑕疵且不做任何明示或暗示的担保，包括但不限于对适销性、与某特定用途的适用性或不侵犯任何第三方知识产权的暗示担保。

这些资源可供使用 TI 产品进行设计的熟练开发人员使用。您将自行承担以下全部责任：(1) 针对您的应用选择合适的 TI 产品，(2) 设计、验证并测试您的应用，(3) 确保您的应用满足相应标准以及任何其他安全、安保法规或其他要求。

这些资源如有变更，恕不另行通知。TI 授权您仅可将这些资源用于研发本资源所述的 TI 产品的相关应用。严禁以其他方式对这些资源进行复制或展示。您无权使用任何其他 TI 知识产权或任何第三方知识产权。对于因您对这些资源的使用而对 TI 及其代表造成的任何索赔、损害、成本、损失和债务，您将全额赔偿，TI 对此概不负责。

TI 提供的产品受 [TI 销售条款](#)、[TI 通用质量指南](#) 或 [ti.com](#) 上其他适用条款或 TI 产品随附的其他适用条款的约束。TI 提供这些资源并不会扩展或以其他方式更改 TI 针对 TI 产品发布的适用的担保或担保免责声明。除非德州仪器 (TI) 明确将某产品指定为定制产品或客户特定产品，否则其产品均为按确定价格收入目录的标准通用器件。

TI 反对并拒绝您可能提出的任何其他或不同的条款。

版权所有 © 2026，德州仪器 (TI) 公司

最后更新日期：2025 年 10 月