

SN74LVC2G241 带三态输出的双路缓冲器和驱动器

1 特性

- 采用德州仪器 (TI) 的 NanoFree™ 封装
- 支持 5V V_{CC} 运行
- 输入电压高达 5.5V
- 电压为 3.3V 时, t_{pd} 最大值为 4.1ns
- 低功耗, I_{CC} 最大值为 10 μ A
- 电压为 3.3V 时, 输出驱动为 ± 24 mA
- $V_{CC} = 3.3$ V, $T_A = 25^\circ\text{C}$ 时, V_{OLP} (输出地弹反射) 典型值小于 0.8V
- $V_{CC} = 3.3$ V, $T_A = 25^\circ\text{C}$ 时, V_{OHV} (输出 V_{OH} 下冲) 典型值大于 2V
- I_{off} 支持带电插入、局部关断模式和后驱动保护
- 可用于下行转换器, 将最高 5.5V 的输入电压下行转换至 V_{CC} 电平
- 闩锁性能超出 JESD 78 II 类规范要求的 100mA
- 静电放电 (ESD) 保护性能超过 JESD 22 规范的要求
 - 2000V 人体放电模型 (A114-A)
 - 200V 机器模型 (A115-A)
 - 1000V 充电器件模型 (C101)

2 应用

- AV 接收机
- 蓝光播放器和家庭影院
- DVD 录像机和播放器
- 台式机或笔记本电脑
- 数字音频广播或互联网广播播放器
- 数码摄像机 (DVC)
- 嵌入式计算机
- GPS: 个人导航设备
- 移动互联网设备
- 网络投影仪前端
- 便携式媒体播放器
- 专业音频混合器

3 说明

此双路缓冲器和线路驱动器适用于 1.65V 至 5.5V V_{CC} 运行环境。

SN74LVC2G241 器件设计用于提高三态存储器地址驱动器、时钟驱动器以及总线导向接收器和发射器的性能和密度。

NanoFree 封装技术是 IC 封装概念的一项重大突破, 它将硅晶片用作封装。

SN74LVC2G241 器件被组织为两个具有独立输出使能 ($1\overline{OE}$, $2OE$) 输入的 1 位线路驱动器。当 $1\overline{OE}$ 为低电平, $2OE$ 为高电平时, 该器件将来自 A 输入的数据传递到 Y 输出。当 $1\overline{OE}$ 为高电平, $2OE$ 为低电平时, 输出处于高阻抗状态。

为了确保在上电或断电期间处于高阻抗状态, 应通过上拉电阻器将 \overline{OE} 接到 V_{CC} , 通过下拉电阻器将 OE 接地; 此电阻器的最小值由驱动器的灌电流能力或拉电流能力决定。

该器件完全适用于使用 I_{off} 的不完全断电应用。 I_{off} 电路会禁用输出, 从而在器件掉电时防止电流回流损坏器件。

器件信息⁽¹⁾

器件型号	封装	封装尺寸 (标称值)
SN74LVC2G241DCT	SM8 (8)	2.95mm × 2.80mm
SN74LVC2G241DCU	VSOOP (8)	2.30mm × 2.00mm
SN74LVC2G241YZP	DSBGA (8)	1.91mm × 0.91mm

(1) 如需了解所有可用封装, 请参阅数据表末尾的可订购产品附录。

逻辑图 (正逻辑)

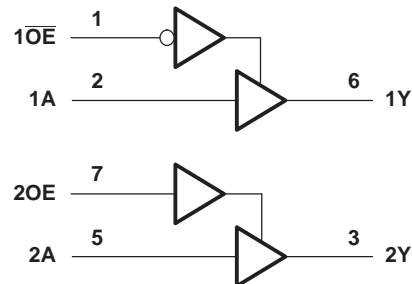

目录

1	特性	1	8.2	Functional Block Diagram	8
2	应用	1	8.3	Feature Description	8
3	说明	1	8.4	Device Functional Modes	8
4	修订历史记录	2	9	Application and Implementation	9
5	Pin Configuration and Functions	3	9.1	Application Information	9
6	Specifications	4	9.2	Typical Application	9
6.1	Absolute Maximum Ratings	4	10	Power Supply Recommendations	10
6.2	ESD Ratings	4	11	Layout	10
6.3	Recommended Operating Conditions	4	11.1	Layout Guidelines	10
6.4	Thermal Information	5	11.2	Layout Example	10
6.5	Electrical Characteristics	5	12	器件和文档支持	11
6.6	Switching Characteristics	6	12.1	文档支持	11
6.7	Operating Characteristics	6	12.2	社区资源	11
6.8	Typical Characteristic	6	12.3	商标	11
7	Parameter Measurement Information	7	12.4	静电放电警告	11
8	Detailed Description	8	12.5	术语表	11
8.1	Overview	8	13	机械、封装和可订购信息	11

4 修订历史记录

注：之前版本的页码可能与当前版本有所不同。

Changes from Revision O (December 2015) to Revision P	Page
• Changed Electrical Characteristics table format	5
• Changed Switching Characteristics tables format	6

Changes from Revision N (November 2013) to Revision O	Page
• 添加了应用部分、器件信息表、ESD 额定值表、热性能信息表、典型特性、特性说明部分、器件功能模式、应用和实施部分、电源建议部分、布局部分、器件和文档支持部分以及机械、封装和可订购信息部分。	1

Changes from Revision M (February 2007) to Revision N	Page
• 将文档更新为新的 TI 数据表格式。	1
• 删除了订购信息表。	1
• 更新了特性中删除了“最高传播延迟低于 1.5ns”。	1
• Updated operating temperature range.	4

5 Pin Configuration and Functions

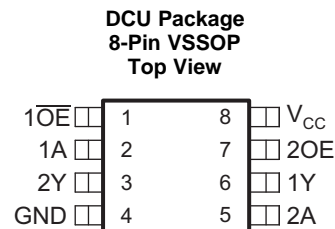
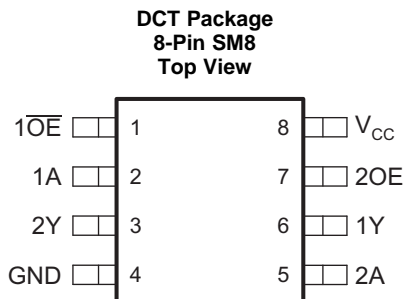

YZP Package
8-Pin DSBGA
Bottom View



Pin Functions⁽¹⁾⁽²⁾

PIN		I/O	DESCRIPTION
NAME	NO.		
1A	2	I	Input
$\overline{1OE}$	1	I	Output enable (Active low)
1Y	6	O	Output
2A	5	I	Input
2Y	3	O	Output
2OE	7	I	Output enable (Active high)
GND	4	—	Ground
V _{CC}	8	—	Power pin

(1) N.C. – No internal connection

(2) See for dimensions

6 Specifications

6.1 Absolute Maximum Ratings

over operating free-air temperature range (unless otherwise noted)⁽¹⁾

			MIN	MAX	UNIT
V _{CC}	Supply voltage		-0.5	6.5	V
V _I	Input voltage ⁽²⁾		-0.5	6.5	V
V _O	Voltage applied to any output in the high-impedance or power-off state ⁽²⁾		-0.5	6.5	V
V _O	Voltage applied to any output in the high or low state ⁽²⁾⁽³⁾		-0.5	V _{CC} + 0.5	V
I _{IK}	Input clamp current	V _I < 0		-50	mA
I _{OK}	Output clamp current	V _O < 0		-50	mA
I _O	Continuous output current			±50	mA
	Continuous current through V _{CC} or GND			±100	mA
T _J	Maximum junction temperature			150	°C
T _{stg}	Storage temperature		-65	150	°C

- (1) Stresses beyond those listed under *Absolute Maximum Ratings* may cause permanent damage to the device. These are stress ratings only, and functional operation of the device at these or any other conditions beyond those indicated under *Recommended Operating Conditions* is not implied. Exposure to absolute-maximum-rated conditions for extended periods may affect device reliability.
- (2) The input negative-voltage and output voltage ratings may be exceeded if the input and output current ratings are observed.
- (3) The value of V_{CC} is provided in the *Recommended Operating Conditions* table.

6.2 ESD Ratings

			VALUE	UNIT
V _(ESD)	Electrostatic discharge	Human-body model (HBM), per ANSI/ESDA/JEDEC JS-001, all pins ⁽¹⁾	±2000	V
		Charged-device model (CDM), per JEDEC specification JESD22-C101, all pins ⁽²⁾	±1000	

- (1) JEDEC document JEP155 states that 500-V HBM allows safe manufacturing with a standard ESD control process.
- (2) JEDEC document JEP157 states that 250-V CDM allows safe manufacturing with a standard ESD control process.

6.3 Recommended Operating Conditions⁽¹⁾

			MIN	MAX	UNIT
V _{CC}	Supply voltage	Operating	1.65	5.5	V
		Data retention only	1.5		
V _{IH}	High-level input voltage	V _{CC} = 1.65 V to 1.95 V	0.65 × V _{CC}		V
		V _{CC} = 2.3 V to 2.7 V	1.7		
		V _{CC} = 3 V to 3.6 V	2		
		V _{CC} = 4.5 V to 5.5 V	0.7 × V _{CC}		
V _{IL}	Low-level input voltage	V _{CC} = 1.65 V to 1.95 V		0.35 × V _{CC}	V
		V _{CC} = 2.3 V to 2.7 V		0.7	
		V _{CC} = 3 V to 3.6 V		0.8	
		V _{CC} = 4.5 V to 5.5 V		0.3 × V _{CC}	
V _I	Input voltage		0	5.5	V
V _O	Output voltage	High or low state	0	V _{CC}	V
		3-state	0	5.5	
I _{OH}	High-level output current	V _{CC} = 1.65 V		-4	mA
		V _{CC} = 2.3 V		-8	
		V _{CC} = 3 V		-16	
		V _{CC} = 4.5 V		-24	

- (1) All unused inputs of the device must be held at V_{CC} or GND to ensure proper device operation. Refer to the TI application report *Implications of Slow or Floating CMOS Inputs*, [SCBA004](#).

Recommended Operating Conditions⁽¹⁾ (continued)

		MIN	MAX	UNIT
I _{OL}	Low-level output current	V _{CC} = 1.65 V	4	mA
		V _{CC} = 2.3 V	8	
		V _{CC} = 3 V	16	
		V _{CC} = 4.5 V	24	
Δt/Δv	Input transition rise or fall rate	V _{CC} = 1.8 V ± 0.15 V, 2.5 V ± 0.2 V	20	ns/V
		V _{CC} = 3.3 V ± 0.3 V	10	
		V _{CC} = 5 V ± 0.5 V	5	
T _A	Operating free-air temperature	-40	85	°C

6.4 Thermal Information

THERMAL METRIC ⁽¹⁾	SN74LVC2G241			UNIT
	DCT (SM8)	DCU (VSSOP)	YZP (DSBGA)	
	8 PINS	8 PINS	8 PINS	
R _{θJA}	Junction-to-ambient thermal resistance			°C/W
	220	227	102	

(1) For more information about traditional and new thermal metrics, see the *Semiconductor and IC Package Thermal Metrics* application report, [SPRA953](#).

6.5 Electrical Characteristics

over recommended operating free-air temperature range, T_A = -40°C to 125°C (unless otherwise noted)

PARAMETER	TEST CONDITIONS	V _{CC}	-40°C to 85°C			-40°C to 125°C (Recommended)			UNIT
			MIN	TYP	MAX	MIN	TYP	MAX	
V _{OH}	I _{OH} = -100 μA	1.65 V to 5.5 V	V _{CC} - 0.1			V _{CC} - 0.1			V
	I _{OH} = -4 mA	1.65 V	1.2			1.2			
	I _{OH} = -8 mA	2.3 V	1.9			1.9			
	I _{OH} = -16 mA	3 V	2.4			2.4			
	I _{OH} = -24 mA		2.3			2.3			
	I _{OH} = -32 mA	4.5 V	3.8			3.8			
V _{OL}	I _{OL} = 100 μA	1.65 V to 5.5 V	0.1			0.1			V
	I _{OL} = 4 mA	1.65 V	0.45			0.45			
	I _{OL} = 8 mA	2.3 V	0.3			0.3			
	I _{OL} = 16 mA	3 V	0.4			0.4			
	I _{OL} = 24 mA		0.55			0.55			
	I _{OL} = 32 mA	4.5 V	0.55			0.75			
I _i	A or \overline{OE} inputs	V _I = 5.5 V or GND	0 to 5.5 V			±5			μA
I _{off}	V _I or V _O = 5.5 V	0	±10			±10			μA
I _{OZ}	V _O = 0 to 5.5 V	3.6 V	10			10			μA
I _{CC}	V _I = 5.5 V or GND, I _O = 0	1.65 V to 5.5 V	10			10			μA
ΔI _{CC}	One input at V _{CC} - 0.6 V, Other inputs at V _{CC} or GND	3 V to 5.5 V	500			500			μA
C _i	Data Inputs	V _I = V _{CC} or GND	3.5						pF
	Control Inputs		4						
C _o	V _O = V _{CC} or GND	3.3 V	6.5						pF

6.6 Switching Characteristics

over recommended operating free-air temperature range (unless otherwise noted) (see Figure 2)

PARAMETER	FROM (INPUT)	TO (OUTPUT)	–40°C to 85°C								UNIT
			$V_{CC} = 1.8\text{ V} \pm 0.15\text{ V}$		$V_{CC} = 2.5\text{ V} \pm 0.2\text{ V}$		$V_{CC} = 3.3\text{ V} \pm 0.3\text{ V}$		$V_{CC} = 5\text{ V} \pm 0.5\text{ V}$		
			MIN	MAX	MIN	MAX	MIN	MAX	MIN	MAX	
t_{pd}	A	Y	3.3	9.1	1.5	5.5	1.4	4.3	1.0	4.0	ns
t_{en}	\overline{OE}	Y	4.0	9.9	1.3	6.6	1.2	4.7	1.1	5.0	ns
t_{dis}	\overline{OE}	Y	1.5	11.6	1.0	5.7	1.4	4.6	0.5	4.2	ns

PARAMETER	FROM (INPUT)	TO (OUTPUT)	–40°C to 125°C (Recommended)								UNIT
			$V_{CC} = 1.8\text{ V} \pm 0.15\text{ V}$		$V_{CC} = 2.5\text{ V} \pm 0.2\text{ V}$		$V_{CC} = 3.3\text{ V} \pm 0.3\text{ V}$		$V_{CC} = 5\text{ V} \pm 0.5\text{ V}$		
			MIN	MAX	MIN	MAX	MIN	MAX	MIN	MAX	
t_{pd}	A	Y	3.3	10.1	1.5	5.6	1.4	5.3	1.0	4.2	ns
t_{en}	\overline{OE}	Y	4.0	10.9	1.3	6.6	1.2	5.7	1.2	4.3	ns
t_{dis}	\overline{OE}	Y	1.5	12.6	1.0	6.6	1.4	5.6	1.0	3.9	ns

6.7 Operating Characteristics

$T_A = 25^\circ\text{C}$

PARAMETER		TEST CONDITIONS	V_{CC}	TYP	UNIT	
C_{pd}	Power dissipation capacitance per buffer/driver	Outputs enabled	$f = 10\text{ MHz}$	$V_{CC} = 1.8\text{ V}$	19	pF
				$V_{CC} = 2.5\text{ V}$	19	
				$V_{CC} = 3.3\text{ V}$	20	
				$V_{CC} = 5\text{ V}$	22	
	Outputs disabled	$V_{CC} = 1.8\text{ V}$	2	pF		
		$V_{CC} = 2.5\text{ V}$	2			
		$V_{CC} = 3.3\text{ V}$	2			
		$V_{CC} = 5\text{ V}$	3			

6.8 Typical Characteristic

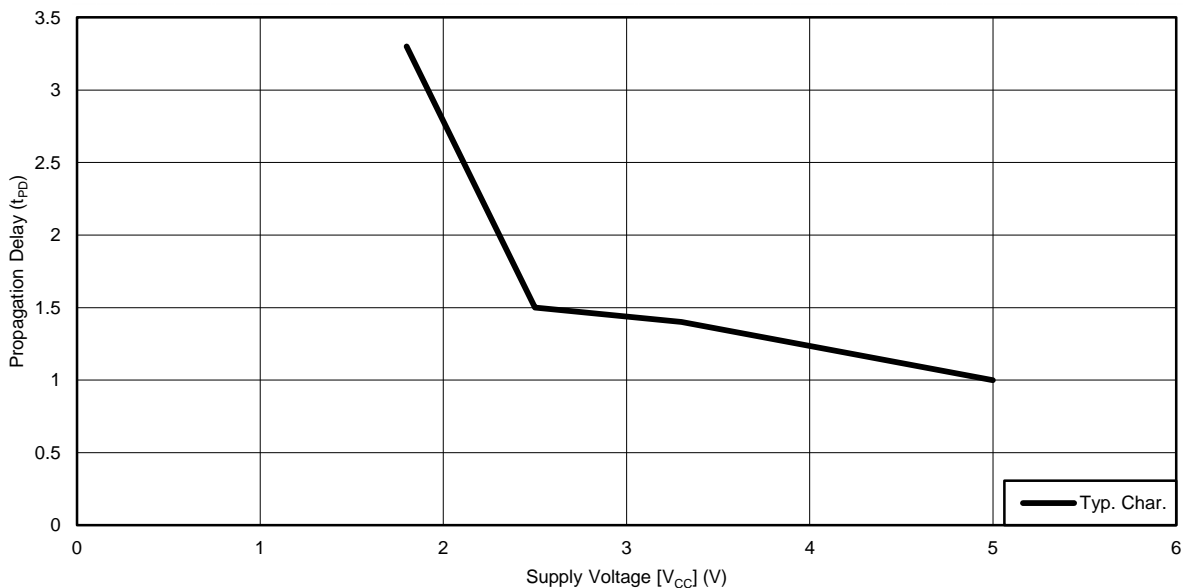
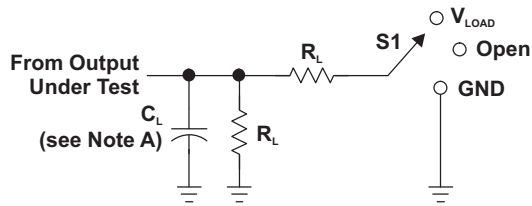

Figure 1. t_{pd} vs V_{CC} Over Full Temperature Range

7 Parameter Measurement Information



LOAD CIRCUIT

TEST	S1
t_{PLH}/t_{PHL}	Open
t_{PLZ}/t_{PZL}	V_{LOAD}
t_{PHZ}/t_{PZH}	GND

V_{CC}	INPUTS		V_M	V_{LOAD}	C_L	R_L	V_{Δ}
	V_i	t_i/t_r					
$1.8\text{ V} \pm 0.15\text{ V}$	V_{CC}	$\leq 2\text{ ns}$	$V_{CC}/2$	$2 \times V_{CC}$	30 pF	1 k Ω	0.15 V
$2.5\text{ V} \pm 0.2\text{ V}$	V_{CC}	$\leq 2\text{ ns}$	$V_{CC}/2$	$2 \times V_{CC}$	30 pF	500 Ω	0.15 V
$3.3\text{ V} \pm 0.3\text{ V}$	3 V	$\leq 2.5\text{ ns}$	1.5 V	6 V	50 pF	500 Ω	0.3 V
$5\text{ V} \pm 0.5\text{ V}$	V_{CC}	$\leq 2.5\text{ ns}$	$V_{CC}/2$	$2 \times V_{CC}$	50 pF	500 Ω	0.3 V

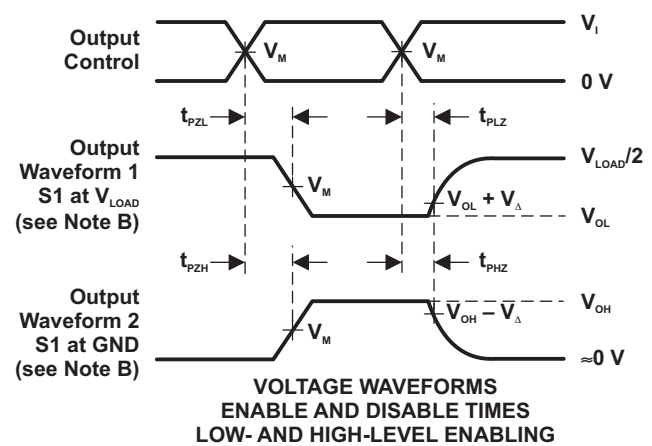
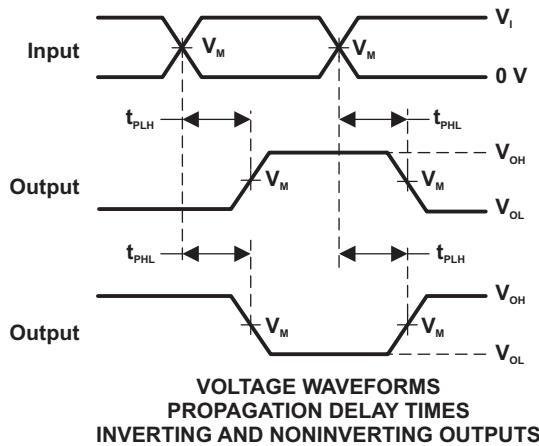
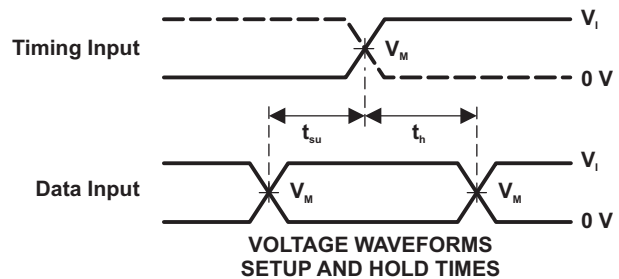
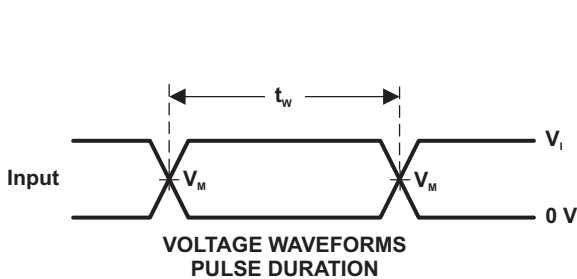

- NOTES:
- A. C_L includes probe and jig capacitance.
 - B. Waveform 1 is for an output with internal conditions such that the output is low, except when disabled by the output control. Waveform 2 is for an output with internal conditions such that the output is high, except when disabled by the output control.
 - C. All input pulses are supplied by generators having the following characteristics: PRR $\leq 10\text{ MHz}$, $Z_o = 50\ \Omega$.
 - D. The outputs are measured one at a time, with one transition per measurement.
 - E. t_{PLZ} and t_{PHZ} are the same as t_{dis} .
 - F. t_{PZL} and t_{PZH} are the same as t_{en} .
 - G. t_{PLH} and t_{PHL} are the same as t_{pd} .
 - H. All parameters and waveforms are not applicable to all devices.

Figure 2. Load Circuit and Voltage Waveforms

8 Detailed Description

8.1 Overview

The SN74LVC2G241 device is designed specifically to improve both the performance and density of 3-state memory-address drivers, clock drivers, and bus-oriented receivers and transmitters. The SN74LVC2G241 device is organized as two 1-bit line drivers with separate output-enable ($\overline{1OE}$, 2OE) inputs. When $\overline{1OE}$ is low and 2OE is high, the device passes data from the A inputs to the Y outputs. When $\overline{1OE}$ is high and 2OE is low, the outputs are in the high-impedance state.

The SN74LVC2G241 is also an effective redriver, with a maximum output current drive of 32 mA.

8.2 Functional Block Diagram

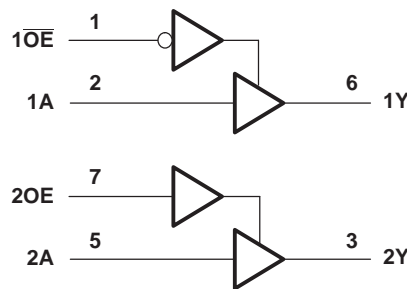

Figure 3. Logic Diagram (Positive Logic)

8.3 Feature Description

To ensure the high-impedance state during power up or power down, \overline{OE} should be tied to V_{CC} through a pullup resistor, and OE should be tied to GND through a pulldown resistor; the minimum value of the resistor is determined by the current-sinking or the current-sourcing capability of the driver.

This device is fully specified for partial-power-down applications using I_{off} . The I_{off} circuitry disables the outputs, preventing damaging current backflow through the device when it is powered down.

8.4 Device Functional Modes

Table 1 and Table 2 list the functional modes of the SN74LVC2G241.

Table 1. Gate 1 Functional Table

INPUTS		OUTPUT 1Y
$\overline{1OE}$	1A	
L	H	H
L	L	L
H	X	Z

Table 2. Gate 2 Functional Table

INPUTS		OUTPUT 2Y
2OE	2A	
H	H	H
H	L	L
L	X	Z

9 Application and Implementation

NOTE

Information in the following applications sections is not part of the TI component specification, and TI does not warrant its accuracy or completeness. TI's customers are responsible for determining suitability of components for their purposes. Customers should validate and test their design implementation to confirm system functionality.

9.1 Application Information

Typical Application shows a simple application where a physical push button is connected to the SN74LVC2G241. The push button is in a physical location far enough away from the processor that the input signal is weak and needs to be redriven. The SN74LVC2G241 acts as a redriver, providing a strong input signal to the processor with as little as 1 ns of propagation delay.

9.2 Typical Application

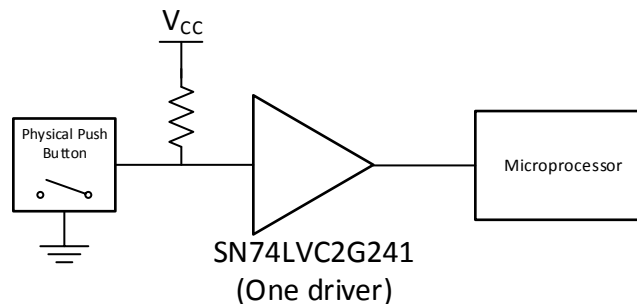

Figure 4. SN74LVC2G241 Application

9.2.1 Design Requirements

This device uses CMOS technology and has balanced output drive. Take care to avoid bus contention because it can drive currents that would exceed maximum limits. The high drive also creates fast edges into light loads, so routing and load conditions must be considered to prevent ringing.

9.2.2 Detailed Design Procedure

1. Recommended Input Conditions
 - Rise time and fall time specs. See ($\Delta t/\Delta V$) in *Recommended Operating Conditions*.
 - Specified high and low levels. See (V_{IH} and V_{IL}) in *Recommended Operating Conditions*.
 - Inputs are overvoltage tolerant allowing them to go as high as (V_I max) in *Recommended Operating Conditions* at any valid V_{CC} .
2. Recommend Output Conditions
 - Load currents must not exceed (I_O max) per output and must not exceed (Continuous current through V_{CC} or GND) total current for the part. These limits are located in *Absolute Maximum Ratings*.
 - Outputs must not be pulled above V_{CC} during normal operation or 5.5 V in high-z state.

Typical Application (continued)

9.2.3 Application Curve

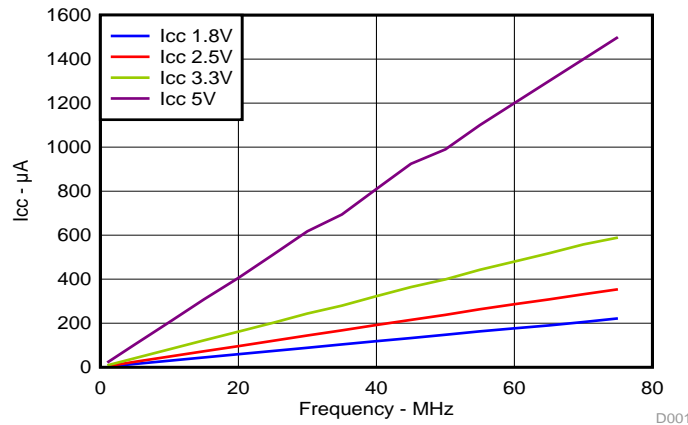

Figure 5. I_{CC} vs Frequency

10 Power Supply Recommendations

The power supply can be any voltage between the minimum and maximum supply voltage rating located in [Recommended Operating Conditions](#).

Each V_{CC} pin should have a good bypass capacitor to prevent power disturbance. For devices with a single supply, a 0.1-µF capacitor is recommended and if there are multiple V_{CC} pins then a 0.01-µF or 0.022-µF capacitor is recommended for each power pin. It is ok to parallel multiple bypass capacitors to reject different frequencies of noise. 0.1-µF and 1-µF capacitors are commonly used in parallel. The bypass capacitor should be installed as close to the power pin as possible for best results.

11 Layout

11.1 Layout Guidelines

When using multiple bit logic devices inputs must not ever float. In many cases, functions or parts of functions of digital logic devices are unused; for example, when only two inputs of a triple-input AND gate are used or only 3 of the 4 buffer gates are used. Such input pins must not be left unconnected because the undefined voltages at the outside connections result in undefined operational states. Specified below are the rules that must be observed under all circumstances. All unused inputs of digital logic devices must be connected to a high or low bias to prevent them from floating. The logic level that should be applied to any particular unused input depends on the function of the device. Generally they will be tied to GND or V_{CC}, whichever make more sense or is more convenient.

11.2 Layout Example

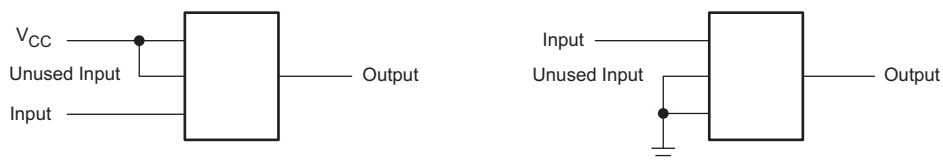

Figure 6. Layout Diagram

12 器件和文档支持

12.1 文档支持

12.1.1 相关文档

如需相关文档，请参阅：

《CMOS 输入缓慢变化或悬空的影响》，[SCBA004](#)

12.2 社区资源

下列链接提供到 TI 社区资源的连接。链接的内容由各个分销商“按照原样”提供。这些内容并不构成 TI 技术规范，并且不一定反映 TI 的观点；请参阅 TI 的《使用条款》。

TI E2E™ 在线社区 **TI 的工程师对工程师 (E2E) 社区**。此社区的创建目的在于促进工程师之间的协作。在 e2e.ti.com 中，您可以咨询问题、分享知识、拓展思路并与同行工程师一道帮助解决问题。

设计支持 **TI 参考设计支持** 可帮助您快速查找有帮助的 E2E 论坛、设计支持工具以及技术支持的联系信息。

12.3 商标

NanoFree, E2E are trademarks of Texas Instruments.
All other trademarks are the property of their respective owners.

12.4 静电放电警告



这些装置包含有限的内置 ESD 保护。存储或装卸时，应将导线一起截短或将装置放置于导电泡棉中，以防止 MOS 门极遭受静电损伤。

12.5 术语表

SLYZ022 — TI 术语表。

这份术语表列出并解释术语、缩写和定义。

13 机械、封装和可订购信息

以下页面包含机械、封装和可订购信息。这些信息是指定器件的最新可用数据。数据如有变更，恕不另行通知，且不会对此文档进行修订。如需获取此数据表的浏览器版本，请查阅左侧的导航栏。

PACKAGING INFORMATION

Orderable part number	Status (1)	Material type (2)	Package Pins	Package qty Carrier	RoHS (3)	Lead finish/ Ball material (4)	MSL rating/ Peak reflow (5)	Op temp (°C)	Part marking (6)
74LVC2G241DCTRE4	Active	Production	SSOP (DCT) 8	3000 LARGE T&R	Yes	NIPDAU	Level-1-260C-UNLIM	-40 to 125	C41 Z
74LVC2G241DCTRE4.B	Active	Production	SSOP (DCT) 8	3000 LARGE T&R	Yes	NIPDAU	Level-1-260C-UNLIM	-40 to 125	C41 Z
74LVC2G241DCTRG4	Active	Production	SSOP (DCT) 8	3000 LARGE T&R	Yes	NIPDAU	Level-1-260C-UNLIM	-40 to 125	C41 Z
74LVC2G241DCTRG4.B	Active	Production	SSOP (DCT) 8	3000 LARGE T&R	Yes	NIPDAU	Level-1-260C-UNLIM	-40 to 125	C41 Z
74LVC2G241DCURG4.B	Active	Production	VSSOP (DCU) 8	3000 LARGE T&R	Yes	NIPDAU	Level-1-260C-UNLIM	-40 to 125	C41R
74LVC2G241DCUTG4	Active	Production	VSSOP (DCU) 8	250 SMALL T&R	Yes	NIPDAU	Level-1-260C-UNLIM	-40 to 125	C41R
74LVC2G241DCUTG4.B	Active	Production	VSSOP (DCU) 8	250 SMALL T&R	Yes	NIPDAU	Level-1-260C-UNLIM	-40 to 125	C41R
SN74LVC2G241DCTR	Active	Production	SSOP (DCT) 8	3000 LARGE T&R	Yes	SN	Level-1-260C-UNLIM	-40 to 125	(2WP5, C41) Z
SN74LVC2G241DCTR.B	Active	Production	SSOP (DCT) 8	3000 LARGE T&R	Yes	SN	Level-1-260C-UNLIM	-40 to 125	(2WP5, C41) Z
SN74LVC2G241DCUR	Active	Production	VSSOP (DCU) 8	3000 LARGE T&R	Yes	NIPDAU SN	Level-1-260C-UNLIM	-40 to 125	(C41J, C41Q, C41R)
SN74LVC2G241DCUR.B	Active	Production	VSSOP (DCU) 8	3000 LARGE T&R	Yes	SN	Level-1-260C-UNLIM	-40 to 125	(C41J, C41Q, C41R)
SN74LVC2G241DCUT	Active	Production	VSSOP (DCU) 8	250 SMALL T&R	Yes	NIPDAU SN	Level-1-260C-UNLIM	-40 to 125	(C41J, C41Q, C41R)
SN74LVC2G241DCUT.B	Active	Production	VSSOP (DCU) 8	250 SMALL T&R	Yes	NIPDAU	Level-1-260C-UNLIM	-40 to 125	(C41J, C41Q, C41R)
SN74LVC2G241DCUTG4.B	Active	Production	VSSOP (DCU) 8	250 SMALL T&R	-	Call TI	Call TI	-40 to 125	
SN74LVC2G241YZPR	Active	Production	DSBGA (YZP) 8	3000 LARGE T&R	Yes	SNAGCU	Level-1-260C-UNLIM	-40 to 125	(C2, C27)
SN74LVC2G241YZPR.B	Active	Production	DSBGA (YZP) 8	3000 LARGE T&R	Yes	SNAGCU	Level-1-260C-UNLIM	-40 to 125	(C2, C27)

(1) **Status:** For more details on status, see our [product life cycle](#).

(2) **Material type:** When designated, preproduction parts are prototypes/experimental devices, and are not yet approved or released for full production. Testing and final process, including without limitation quality assurance, reliability performance testing, and/or process qualification, may not yet be complete, and this item is subject to further changes or possible discontinuation. If available for ordering, purchases will be subject to an additional waiver at checkout, and are intended for early internal evaluation purposes only. These items are sold without warranties of any kind.

(3) **RoHS values:** Yes, No, RoHS Exempt. See the [TI RoHS Statement](#) for additional information and value definition.

(4) **Lead finish/Ball material:** Parts may have multiple material finish options. Finish options are separated by a vertical ruled line. Lead finish/Ball material values may wrap to two lines if the finish value exceeds the maximum column width.

(5) **MSL rating/Peak reflow:** The moisture sensitivity level ratings and peak solder (reflow) temperatures. In the event that a part has multiple moisture sensitivity ratings, only the lowest level per JEDEC standards is shown. Refer to the shipping label for the actual reflow temperature that will be used to mount the part to the printed circuit board.

(6) **Part marking:** There may be an additional marking, which relates to the logo, the lot trace code information, or the environmental category of the part.

Multiple part markings will be inside parentheses. Only one part marking contained in parentheses and separated by a "~" will appear on a part. If a line is indented then it is a continuation of the previous line and the two combined represent the entire part marking for that device.

Important Information and Disclaimer: The information provided on this page represents TI's knowledge and belief as of the date that it is provided. TI bases its knowledge and belief on information provided by third parties, and makes no representation or warranty as to the accuracy of such information. Efforts are underway to better integrate information from third parties. TI has taken and continues to take reasonable steps to provide representative and accurate information but may not have conducted destructive testing or chemical analysis on incoming materials and chemicals. TI and TI suppliers consider certain information to be proprietary, and thus CAS numbers and other limited information may not be available for release.

In no event shall TI's liability arising out of such information exceed the total purchase price of the TI part(s) at issue in this document sold by TI to Customer on an annual basis.

TAPE AND REEL INFORMATION

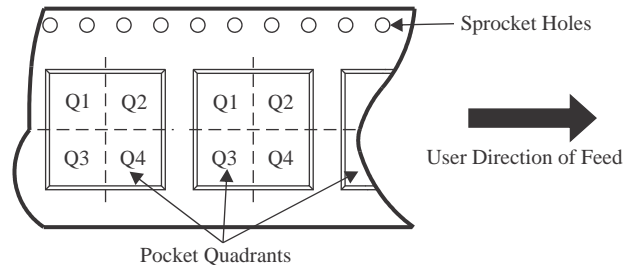
QUADRANT ASSIGNMENTS FOR PIN 1 ORIENTATION IN TAPE

*All dimensions are nominal

Device	Package Type	Package Drawing	Pins	SPQ	Reel Diameter (mm)	Reel Width W1 (mm)	A0 (mm)	B0 (mm)	K0 (mm)	P1 (mm)	W (mm)	Pin1 Quadrant
74LVC2G241DCTRE4	SSOP	DCT	8	3000	180.0	13.0	3.35	4.5	1.55	4.0	12.0	Q3
74LVC2G241DCTRG4	SSOP	DCT	8	3000	180.0	13.0	3.35	4.5	1.55	4.0	12.0	Q3
74LVC2G241DCUTG4	VSSOP	DCU	8	250	180.0	8.4	2.25	3.35	1.05	4.0	8.0	Q3
SN74LVC2G241DCTR	SSOP	DCT	8	3000	180.0	12.4	3.15	4.35	1.55	4.0	12.0	Q3
SN74LVC2G241DCUR	VSSOP	DCU	8	3000	178.0	9.0	2.25	3.35	1.05	4.0	8.0	Q3
SN74LVC2G241DCUT	VSSOP	DCU	8	250	178.0	9.0	2.25	3.35	1.05	4.0	8.0	Q3
SN74LVC2G241YZPR	DSBGA	YZP	8	3000	180.0	8.4	1.02	2.02	0.63	4.0	8.0	Q1

TAPE AND REEL BOX DIMENSIONS

*All dimensions are nominal

Device	Package Type	Package Drawing	Pins	SPQ	Length (mm)	Width (mm)	Height (mm)
74LVC2G241DCTRE4	SSOP	DCT	8	3000	182.0	182.0	20.0
74LVC2G241DCTRG4	SSOP	DCT	8	3000	182.0	182.0	20.0
74LVC2G241DCUTG4	VSSOP	DCU	8	250	202.0	201.0	28.0
SN74LVC2G241DCTR	SSOP	DCT	8	3000	190.0	190.0	30.0
SN74LVC2G241DCUR	VSSOP	DCU	8	3000	180.0	180.0	18.0
SN74LVC2G241DCUT	VSSOP	DCU	8	250	180.0	180.0	18.0
SN74LVC2G241YZPR	DSBGA	YZP	8	3000	182.0	182.0	20.0

YZP0008

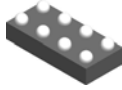

PACKAGE OUTLINE

DSBGA - 0.5 mm max height

DIE SIZE BALL GRID ARRAY

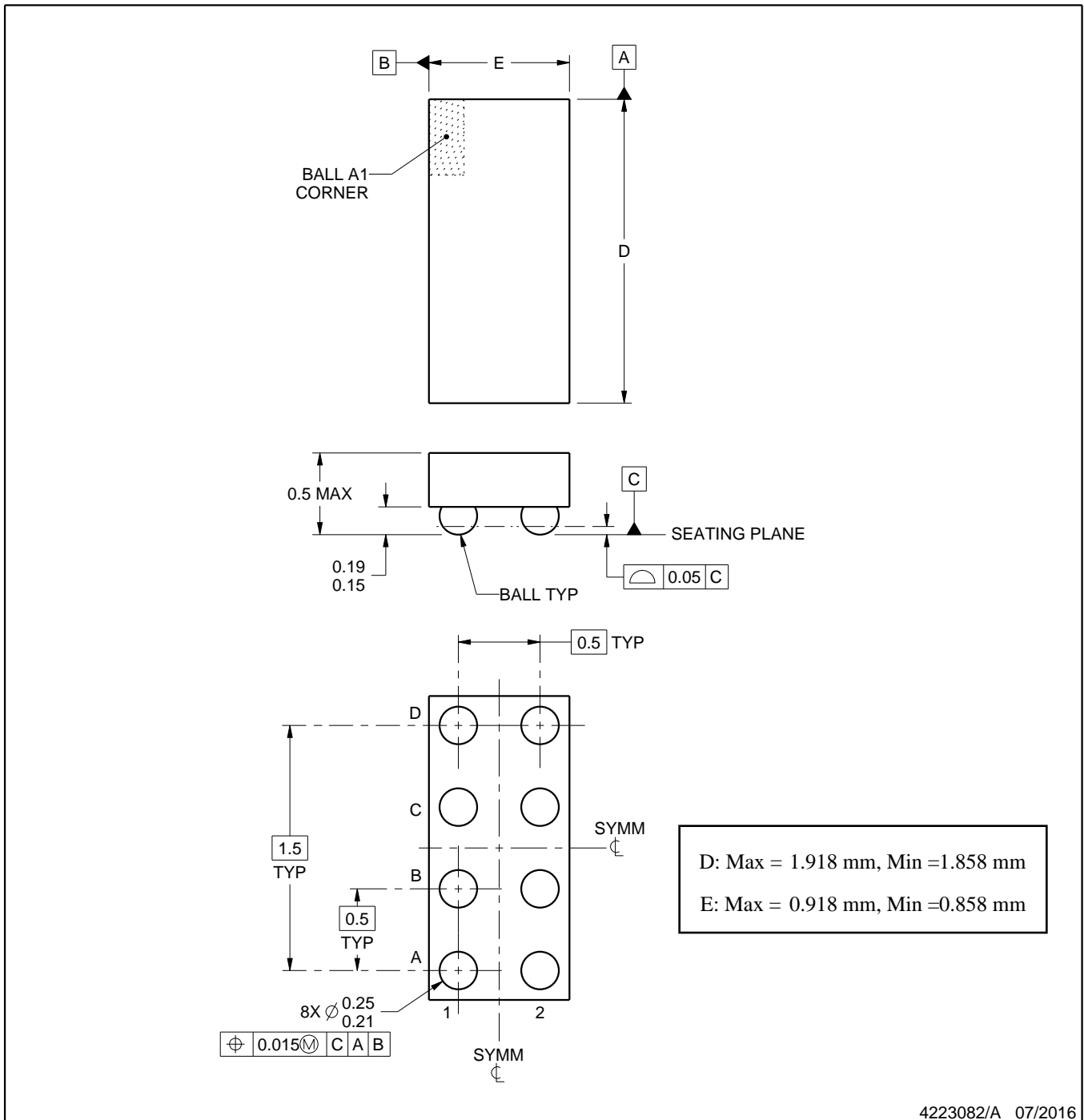

4223082/A 07/2016

NOTES:

1. All linear dimensions are in millimeters. Any dimensions in parenthesis are for reference only. Dimensioning and tolerancing per ASME Y14.5M.
2. This drawing is subject to change without notice.

EXAMPLE BOARD LAYOUT

YZP0008

DSBGA - 0.5 mm max height

DIE SIZE BALL GRID ARRAY

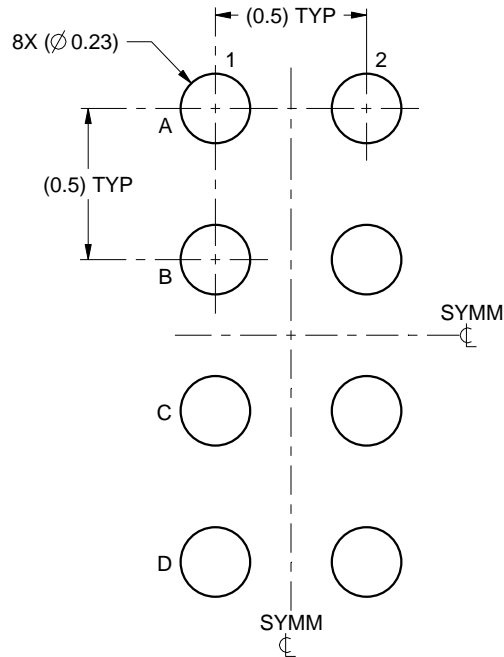

LAND PATTERN EXAMPLE
SCALE:40X

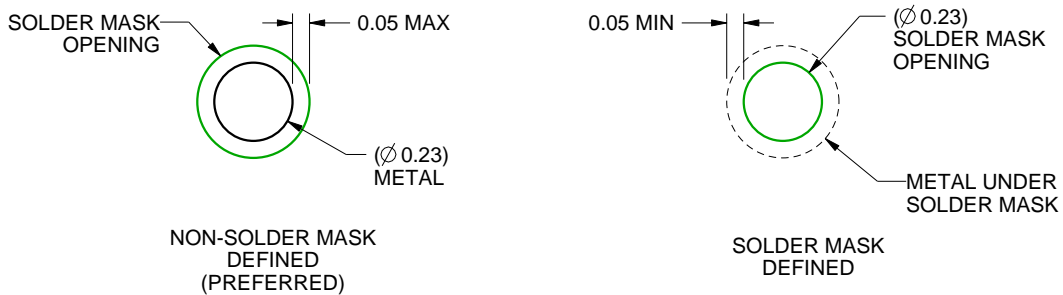

SOLDER MASK DETAILS
NOT TO SCALE

4223082/A 07/2016

NOTES: (continued)

3. Final dimensions may vary due to manufacturing tolerance considerations and also routing constraints. For more information, see Texas Instruments literature number SNVA009 (www.ti.com/lit/snva009).

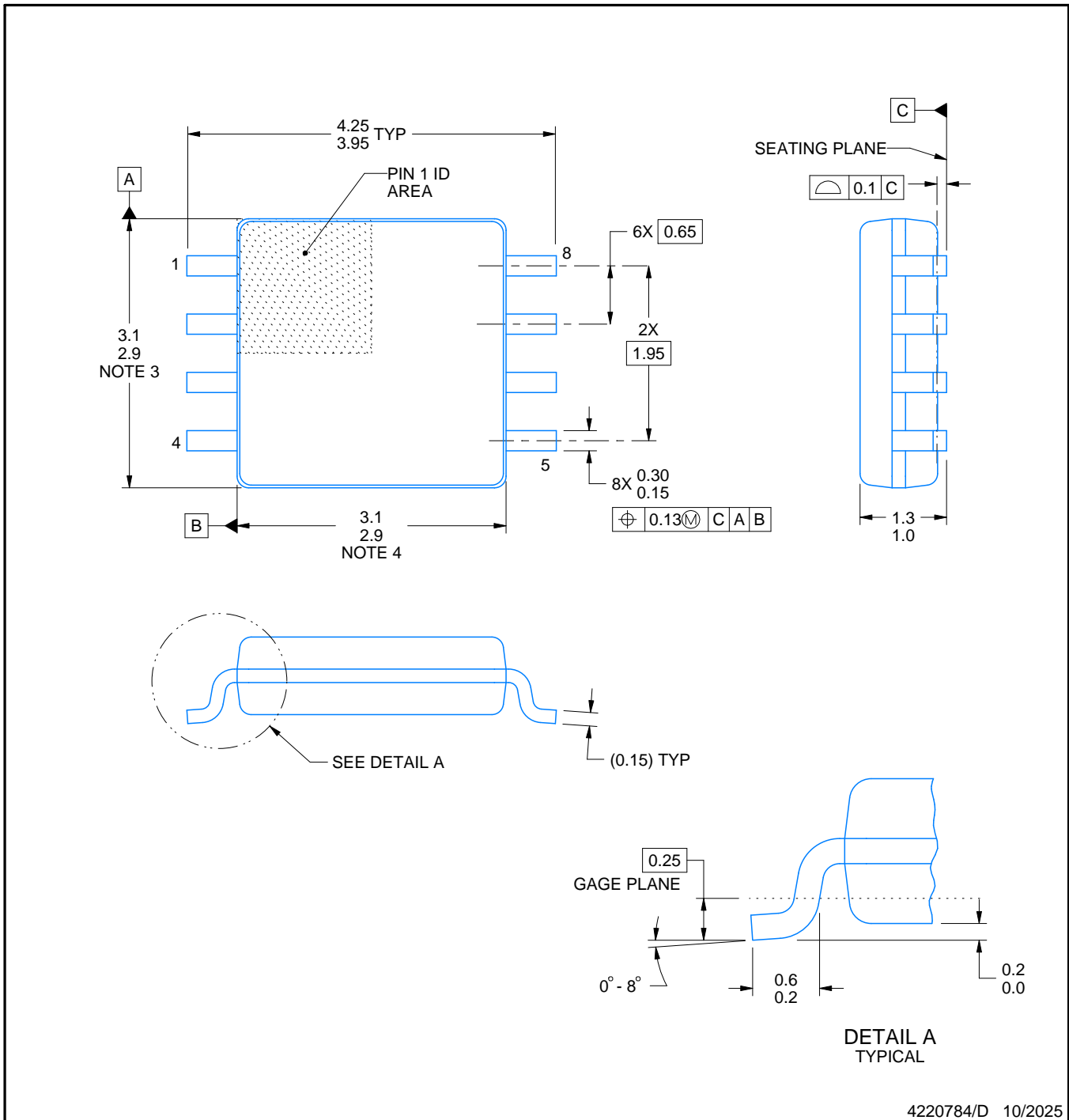
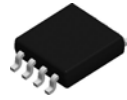

4220784/D 10/2025

NOTES:

1. All linear dimensions are in millimeters. Dimensions in parenthesis are for reference only. Dimensioning and tolerancing per ASME Y14.5M.
2. This drawing is subject to change without notice.
3. This dimension does not include mold flash, protrusions, or gate burrs. Mold flash, protrusions, or gate burrs shall not exceed 0.15 mm per side.
4. This dimension does not include interlead flash. Interlead flash shall not exceed 0.25 mm per side.

EXAMPLE BOARD LAYOUT

DCT0008A

SSOP - 1.3 mm max height

SMALL OUTLINE PACKAGE

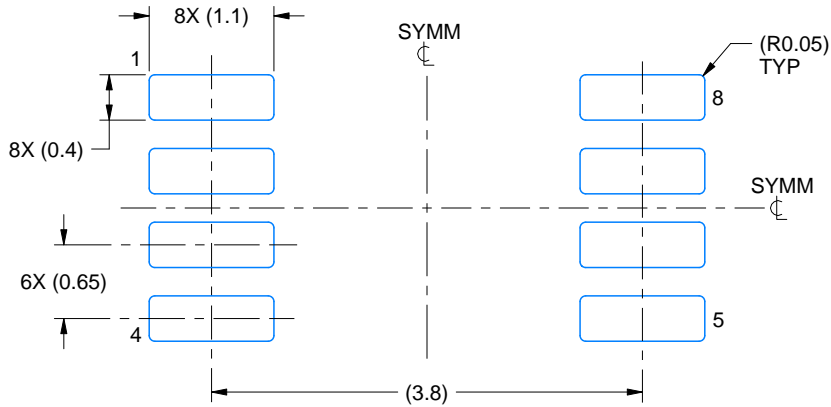

LAND PATTERN EXAMPLE
EXPOSED METAL SHOWN
SCALE:15X

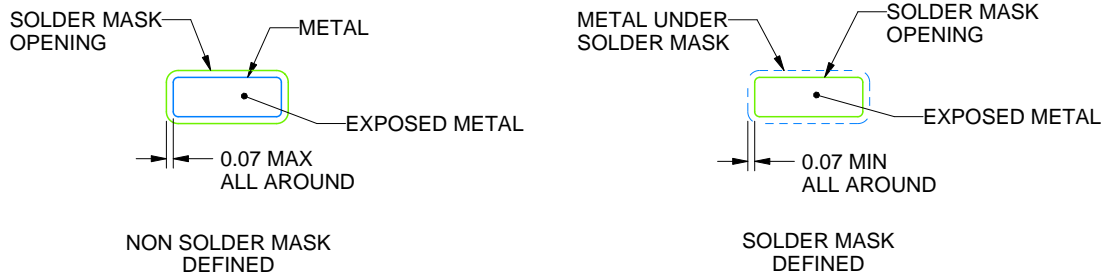

SOLDER MASK DETAILS

4220784/D 10/2025

NOTES: (continued)

- 5. Publication IPC-7351 may have alternate designs.
- 6. Solder mask tolerances between and around signal pads can vary based on board fabrication site.

EXAMPLE STENCIL DESIGN

DCT0008A

SSOP - 1.3 mm max height

SMALL OUTLINE PACKAGE

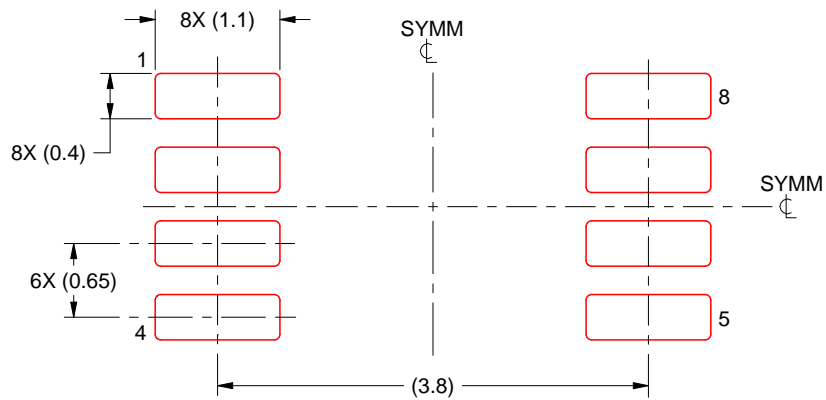

SOLDER PASTE EXAMPLE
BASED ON 0.125 mm THICK STENCIL
SCALE:15X

4220784/D 10/2025

NOTES: (continued)

7. Laser cutting apertures with trapezoidal walls and rounded corners may offer better paste release. IPC-7525 may have alternate design recommendations.
8. Board assembly site may have different recommendations for stencil design.

DCU0008A



PACKAGE OUTLINE

VSSOP - 0.9 mm max height

SMALL OUTLINE PACKAGE

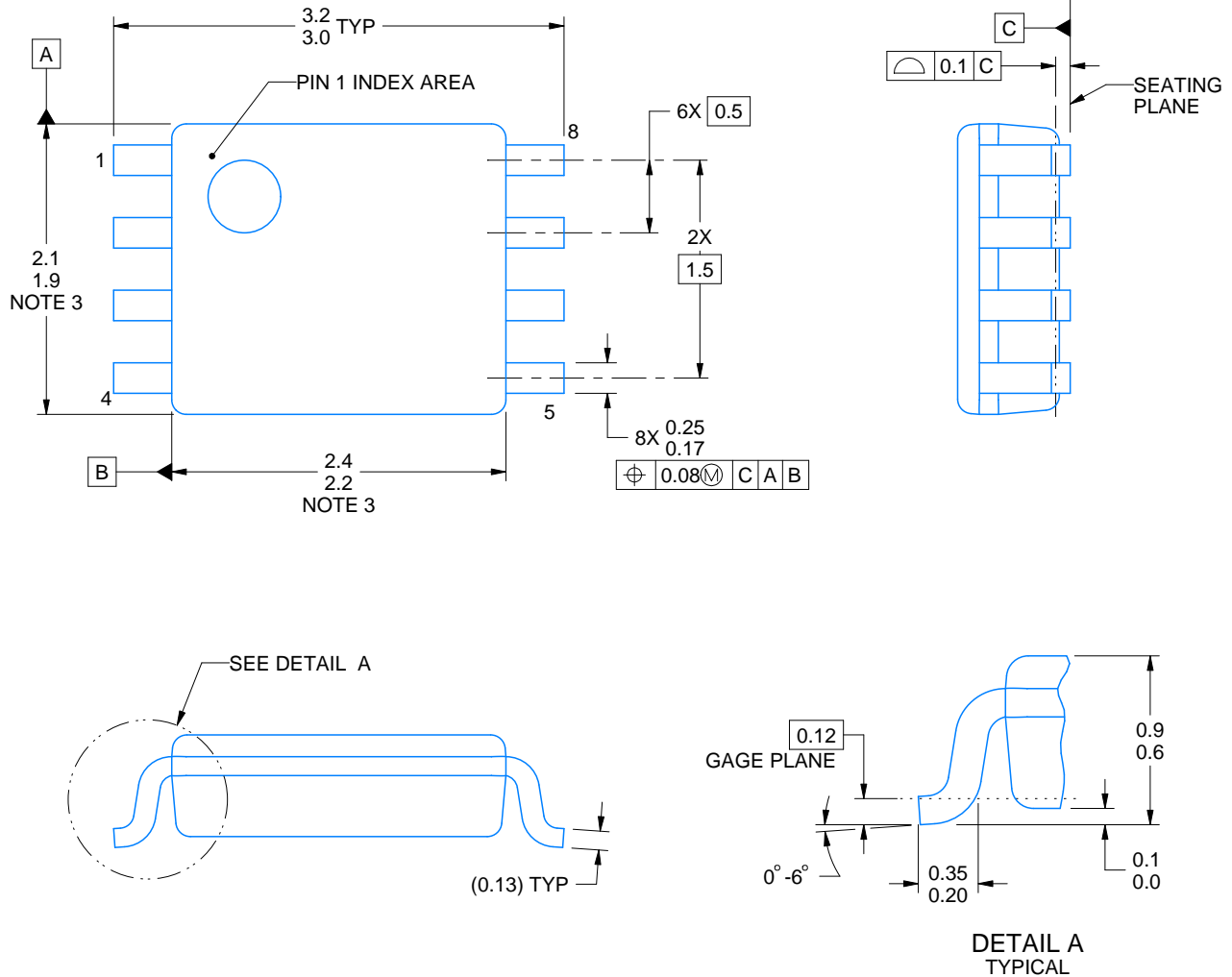

4225266/A 09/2014

NOTES:

1. All linear dimensions are in millimeters. Any dimensions in parenthesis are for reference only. Dimensioning and tolerancing per ASME Y14.5M.
2. This drawing is subject to change without notice.
3. This dimension does not include mold flash, protrusions, or gate burrs. Mold flash, protrusions, or gate burrs shall not exceed 0.15 mm per side.
4. Reference JEDEC registration MO-187 variation CA.

EXAMPLE BOARD LAYOUT

DCU0008A

VSSOP - 0.9 mm max height

SMALL OUTLINE PACKAGE

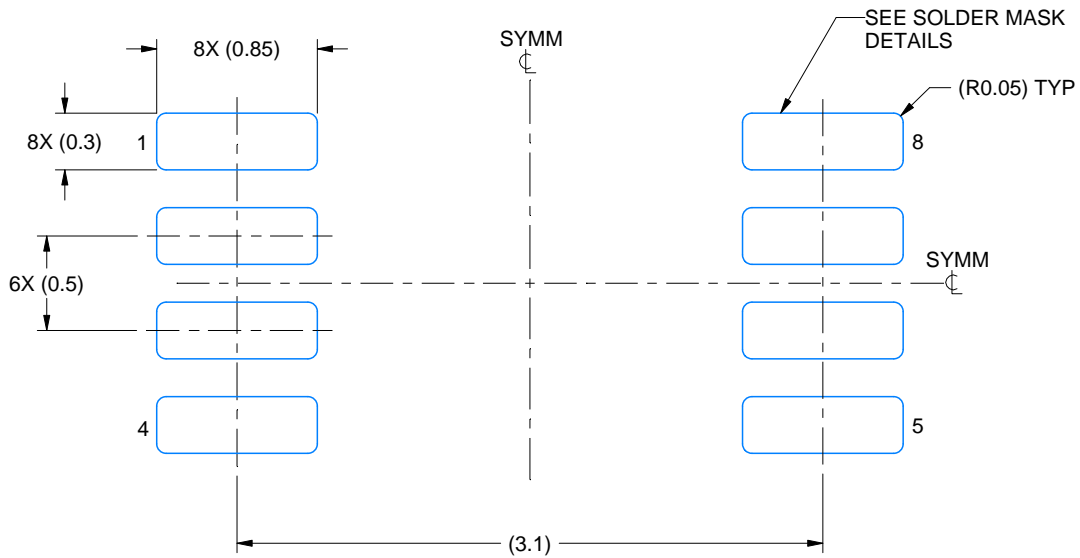

LAND PATTERN EXAMPLE
EXPOSED METAL SHOWN
SCALE: 25X

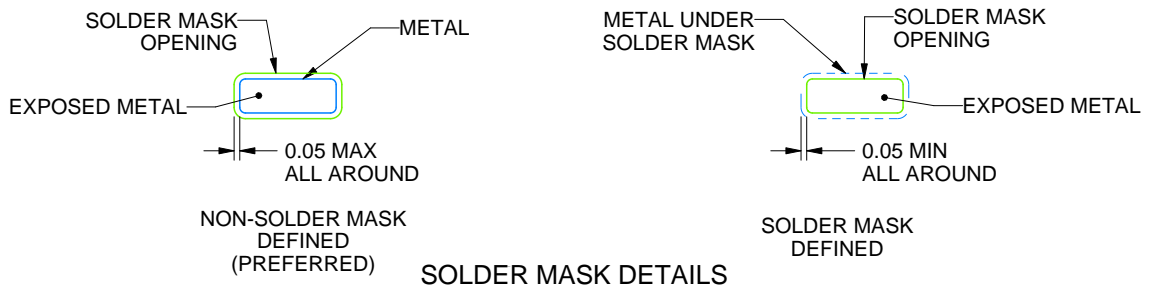

4225266/A 09/2014

NOTES: (continued)

- 5. Publication IPC-7351 may have alternate designs.
- 6. Solder mask tolerances between and around signal pads can vary based on board fabrication site.

EXAMPLE STENCIL DESIGN

DCU0008A

VSSOP - 0.9 mm max height

SMALL OUTLINE PACKAGE

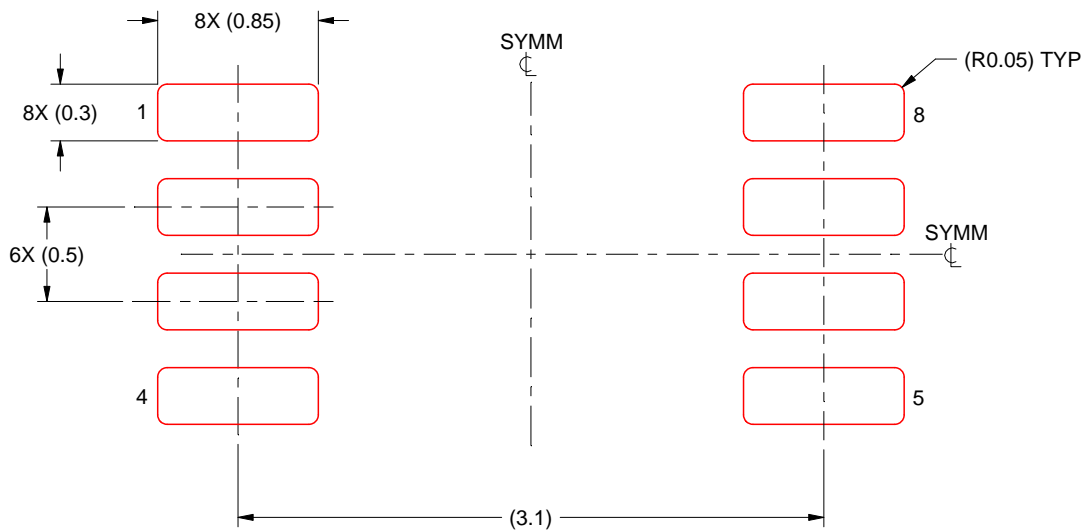

SOLDER PASTE EXAMPLE
BASED ON 0.125 mm THICK STENCIL
SCALE: 25X

4225266/A 09/2014

NOTES: (continued)

7. Laser cutting apertures with trapezoidal walls and rounded corners may offer better paste release. IPC-7525 may have alternate design recommendations.
8. Board assembly site may have different recommendations for stencil design.

重要通知和免责声明

TI“按原样”提供技术和可靠性数据（包括数据表）、设计资源（包括参考设计）、应用或其他设计建议、网络工具、安全信息和其他资源，不保证没有瑕疵且不做任何明示或暗示的担保，包括但不限于对适销性、与某特定用途的适用性或不侵犯任何第三方知识产权的暗示担保。

这些资源可供使用 TI 产品进行设计的熟练开发人员使用。您将自行承担以下全部责任：(1) 针对您的应用选择合适的 TI 产品，(2) 设计、验证并测试您的应用，(3) 确保您的应用满足相应标准以及任何其他安全、安保法规或其他要求。

这些资源如有变更，恕不另行通知。TI 授权您仅可将这些资源用于研发本资源所述的 TI 产品的相关应用。严禁以其他方式对这些资源进行复制或展示。您无权使用任何其他 TI 知识产权或任何第三方知识产权。对于因您对这些资源的使用而对 TI 及其代表造成的任何索赔、损害、成本、损失和债务，您将全额赔偿，TI 对此概不负责。

TI 提供的产品受 [TI 销售条款](#)、[TI 通用质量指南](#) 或 [ti.com](#) 上其他适用条款或 TI 产品随附的其他适用条款的约束。TI 提供这些资源并不会扩展或以其他方式更改 TI 针对 TI 产品发布的适用的担保或担保免责声明。除非德州仪器 (TI) 明确将某产品指定为定制产品或客户特定产品，否则其产品均为按确定价格收入目录的标准通用器件。

TI 反对并拒绝您可能提出的任何其他或不同的条款。

版权所有 © 2026，德州仪器 (TI) 公司

最后更新日期：2025 年 10 月