

LM2776 开关电容反相器

1 特性

- 输入电压：2.7V 至 5.5V
- 200mA 输出电流
- 将输入电源电压反相
- 低电流脉频调制 (PFM) 模式操作
- 2MHz 开关频率
- 效率高达 90% 以上
- 限流和热保护
- 无电感

2 应用

- 运算放大器电源
- 接口电源
- 数据转换器电源
- 音频放大器电源
- 便携式电子设备

3 说明

LM2776 CMOS 电荷泵电压转换器可将 2.7V 至 5.5V 范围内的正电压反相，从而获得对应的等值负电压。LM2776 采用三个低成本电容即可提供 200mA 的输出电流，相比基于电感的转换器，解决了成本、尺寸和电磁干扰 (EMI) 多方面问题。

在大多数负载条件下，LM2776 的工作电流仅为 100 μ A，而工作效率高达 90% 以上，这对于需要高功率负电源的电池供电类系统而言堪称理想性能。

LM2776 一直以来始终采用 TI 的 6 引脚小外形尺寸晶体管 (SOT)-23 封装以保持小巧外形。

器件信息⁽¹⁾

器件型号	封装	封装尺寸 (标称值)
LM2776	SOT-23 (6)	2.90mm x 1.60mm

(1) 要了解所有可用封装，请见数据表末尾的可订购产品附录。

典型应用

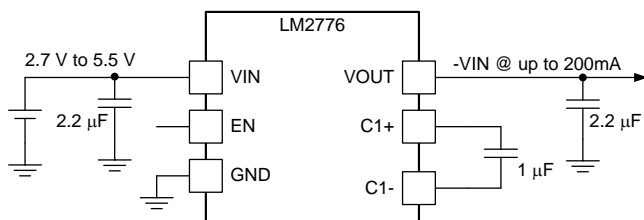

输出阻抗与输入电压间的关系 ($I_{OUT} = 100mA$)

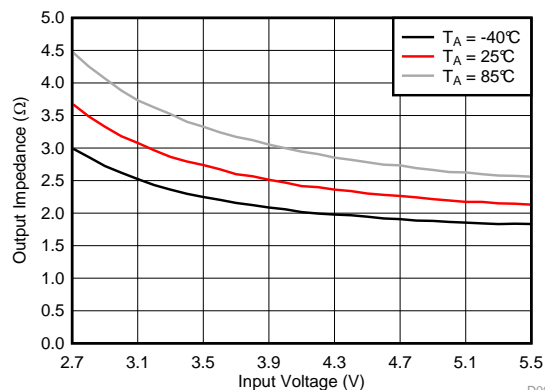

D005



目录

1	特性	1	7.4	Device Functional Modes.....	10
2	应用	1	8	Application and Implementation	11
3	说明	1	8.1	Application Information.....	11
4	修订历史记录	2	8.2	Typical Application - Voltage Inverter	11
5	Pin Configuration and Functions	3	9	Power Supply Recommendations	15
6	Specifications	4	10	Layout	15
6.1	Absolute Maximum Ratings	4	10.1	Layout Guidelines	15
6.2	ESD Ratings.....	4	10.2	Layout Example	15
6.3	Recommended Operating Conditions.....	4	11	器件和文档支持	16
6.4	Thermal Information	4	11.1	器件支持	16
6.5	Electrical Characteristics.....	5	11.2	接收文档更新通知	16
6.6	Switching Characteristics	5	11.3	社区资源	16
6.7	Typical Characteristics	5	11.4	商标	16
7	Detailed Description	9	11.5	静电放电警告	16
7.1	Overview	9	11.6	Glossary	16
7.2	Functional Block Diagram	9	12	机械、封装和可订购信息	16
7.3	Feature Description.....	9			

4 修订历史记录

注：之前版本的页码可能与当前版本有所不同。

Changes from Revision A (February 2016) to Revision B	Page
• 已添加 为 TIDA-01063 参考设计添加了链接	1

Changes from Original (May 2015) to Revision A	Page
• Changed Equation 1 from " $R_{OUT} = R_{SW}...$ " to " $R_{OUT} = (2 \times R_{SW})...$ "	12

5 Pin Configuration and Functions

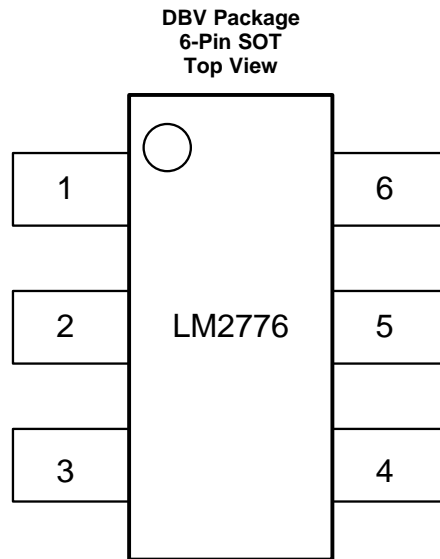

Pin Functions

PIN		TYPE	DESCRIPTION
NUMBER	NAME		
1	VOUT	Output/Power	Negative voltage output.
2	GND	Ground	Power supply ground input.
3	VIN	Input/Power	Power supply positive voltage input.
4	EN	Input	Enable control pin, tie this pin high (EN = 1) for normal operation, and to GND (EN = 0) for shutdown.
5	C1+	Power	Connect this pin to the positive terminal of the charge-pump capacitor.
6	C1-	Power	Connect this pin to the negative terminal of the charge-pump capacitor.

6 Specifications

6.1 Absolute Maximum Ratings

over operating free-air temperature range (unless otherwise noted)⁽¹⁾⁽²⁾

	MIN	MAX	UNIT
Supply voltage (VIN to GND, or GND to VOUT)		6	V
EN	(GND - 0.3)	(VIN + 0.3)	V
VOUT continuous output current		250	mA
Operating junction temperature, T _{JMax} ⁽³⁾		125	°C
Storage temperature, T _{stg}	-65	150	°C

- (1) Stresses beyond those listed under *Absolute Maximum Ratings* may cause permanent damage to the device. These are stress ratings only, which do not imply functional operation of the device at these or any other conditions beyond those indicated under *Recommended Operating Conditions*. Exposure to absolute-maximum-rated conditions for extended periods may affect device reliability.
- (2) If Military/Aerospace specified devices are required, contact the Texas Instruments Sales Office/Distributors for availability and specifications.
- (3) The maximum allowable power dissipation is calculated by using $P_{DMax} = (T_{JMax} - T_A) / R_{\theta JA}$, where T_{JMax} is the maximum junction temperature, T_A is the ambient temperature, and R_{θJA} is the junction-to-ambient thermal resistance of the specified package.

6.2 ESD Ratings

		VALUE	UNIT	
V _(ESD)	Electrostatic discharge	Human-body model (HBM), per ANSI/ESDA/JEDEC JS-001 ⁽¹⁾	±1000	V
		Charged-device model (CDM), per JEDEC specification JESD22-C101 ⁽²⁾	±250	V

- (1) JEDEC document JEP155 states that 500-V HBM allows safe manufacturing with a standard ESD control process.
- (2) JEDEC document JEP157 states that 250-V CDM allows safe manufacturing with a standard ESD control process.

6.3 Recommended Operating Conditions

over operating free-air temperature range (unless otherwise noted)

	MIN	NOM	MAX	UNIT
Junction temperature	-40		125	°C
Ambient temperature	-40		85	°C
Input voltage	2.7		5.5	V
Output current	0		200	mA

6.4 Thermal Information

THERMAL METRIC ⁽¹⁾		LM2776	UNIT
		DBV (SOT)	
		6 PINS	
R _{θJA}	Junction-to-ambient thermal resistance	187	°C/W
R _{θJC(top)}	Junction-to-case (top) thermal resistance	158.2	°C/W
R _{θJB}	Junction-to-board thermal resistance	33.3	°C/W
Ψ _{JT}	Junction-to-top characterization parameter	37.8	°C/W
Ψ _{JB}	Junction-to-board characterization parameter	32.8	°C/W

- (1) For more information about traditional and new thermal metrics, see the *Semiconductor and IC Package Thermal Metrics* application report, [SPRA953](#).

6.5 Electrical Characteristics

Typical limits tested at $T_A = 25^\circ\text{C}$. Minimum and maximum limits apply over the full operating ambient temperature range ($-40^\circ\text{C} \leq T_A \leq +85^\circ\text{C}$). $V_{IN} = 3.6\text{ V}$, $C_{IN} = C_{OUT} = 2.2\ \mu\text{F}$, $C_1 = 1\ \mu\text{F}$

PARAMETER	TEST CONDITIONS	MIN	TYP	MAX	UNIT
I_Q	Supply current		100	200	μA
I_{SD}	Shutdown supply current		0.1	1	μA
V_{EN}	Enable pin input threshold voltage	Normal operation			V
		Shutdown mode			
R_{OUT}	Output resistance		2.5		Ω
I_{CL}	Output current limit		400		mA
UVLO	Undervoltage lockout	V_{IN} Falling			V
		V_{IN} Rising			

6.6 Switching Characteristics

over operating free-air temperature range (unless otherwise noted)

PARAMETER	TEST CONDITIONS	MIN	TYP	MAX	UNIT
f_{SW}	Switching frequency	1.7	2	2.3	MHz

6.7 Typical Characteristics

(典型应用 circuit, $V_{IN} = 3.6\text{ V}$ unless otherwise specified.)

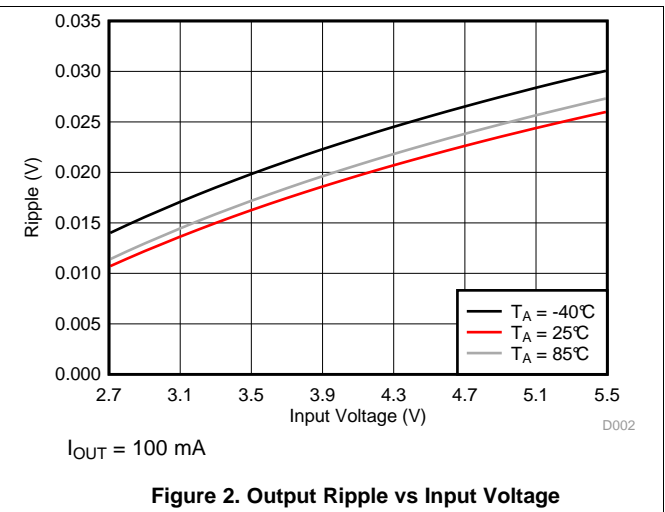
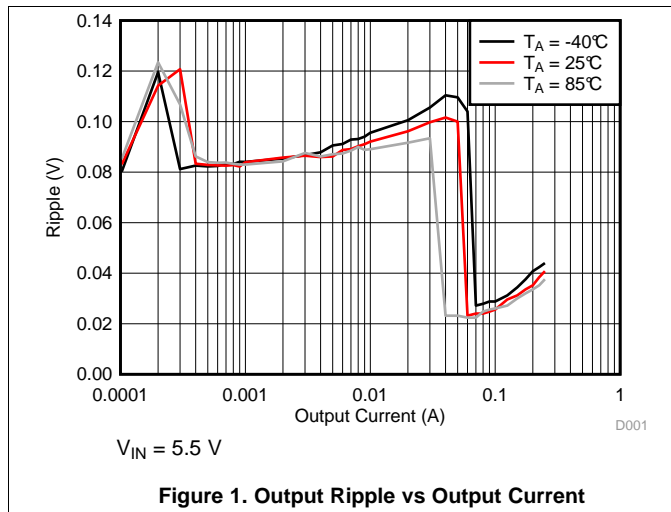

Typical Characteristics (continued)

(典型应用 circuit, $V_{IN} = 3.6\text{ V}$ unless otherwise specified.)

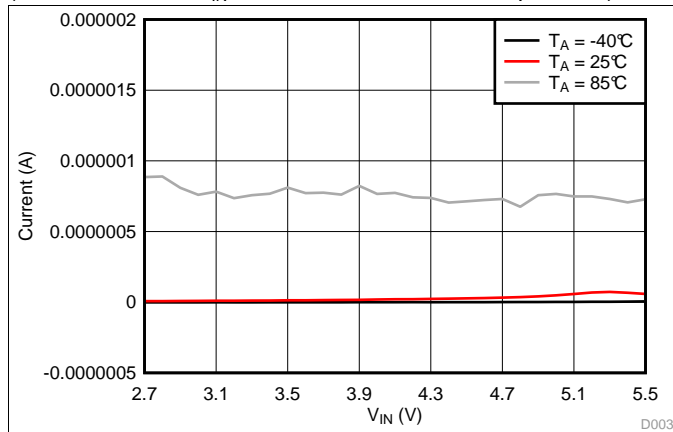
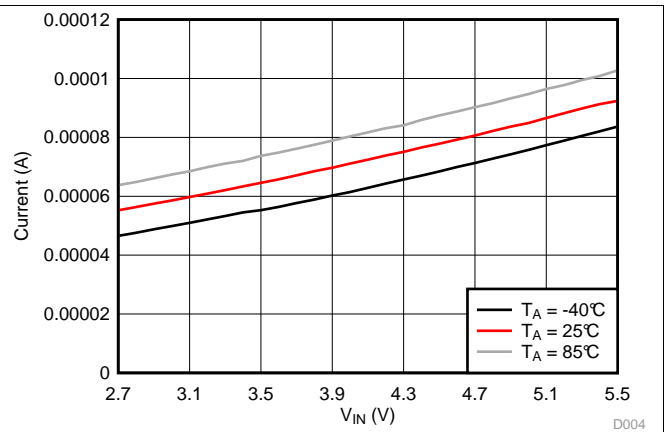
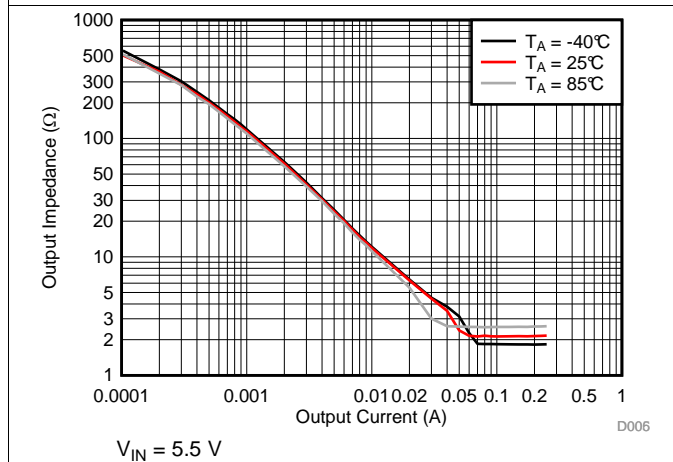

Figure 3. Shutdown Current vs Input Voltage



No load

Figure 4. Quiescent Current vs Input Voltage



$V_{IN} = 5.5\text{ V}$

Figure 5. Output Impedance vs Output Current

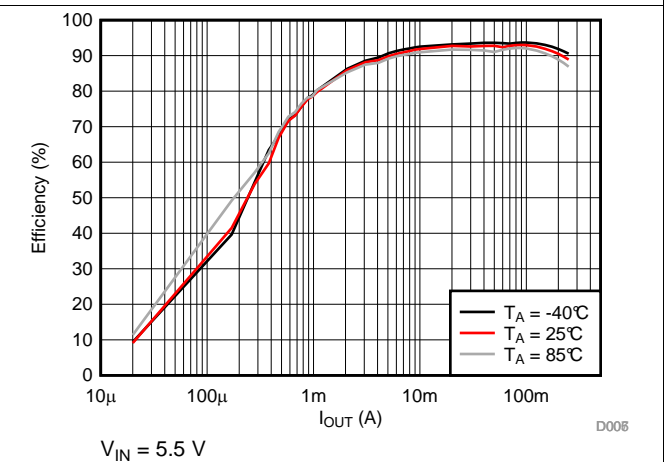

$V_{IN} = 5.5\text{ V}$

Figure 6. Efficiency vs Output Current

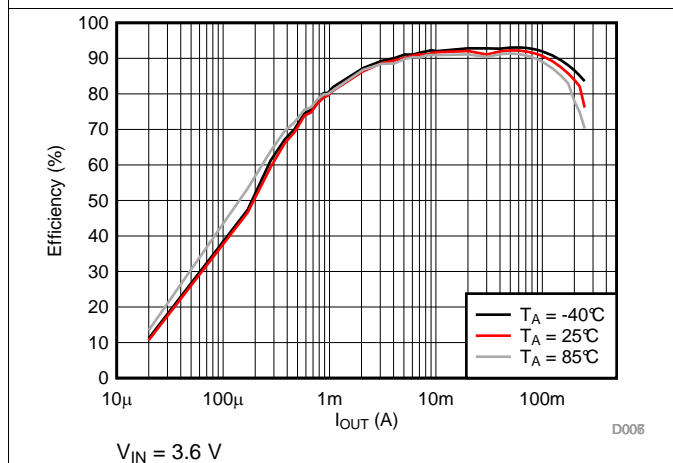

$V_{IN} = 3.6\text{ V}$

Figure 7. Efficiency vs Output Current

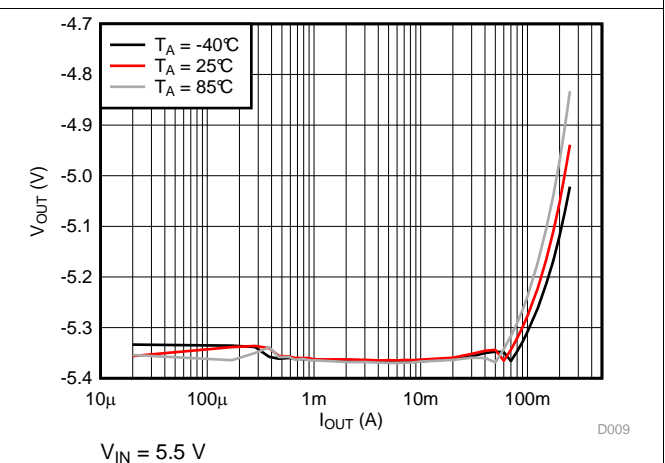

$V_{IN} = 5.5\text{ V}$

Figure 8. Output Voltage vs Output Current

Typical Characteristics (continued)

(典型应用 circuit, $V_{IN} = 3.6\text{ V}$ unless otherwise specified.)

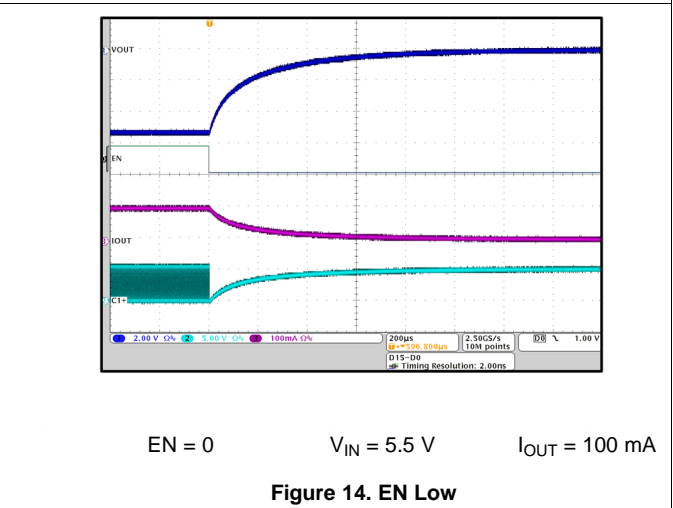
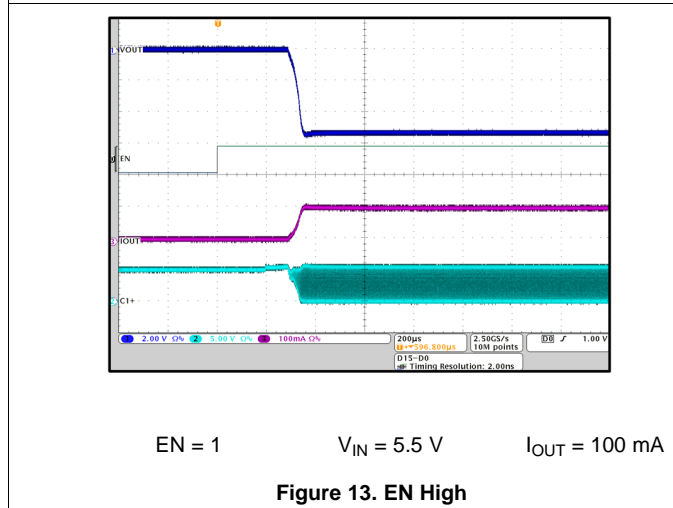
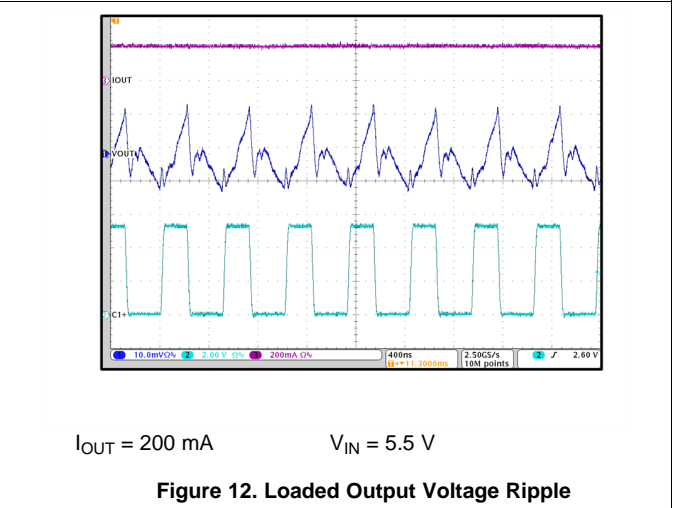
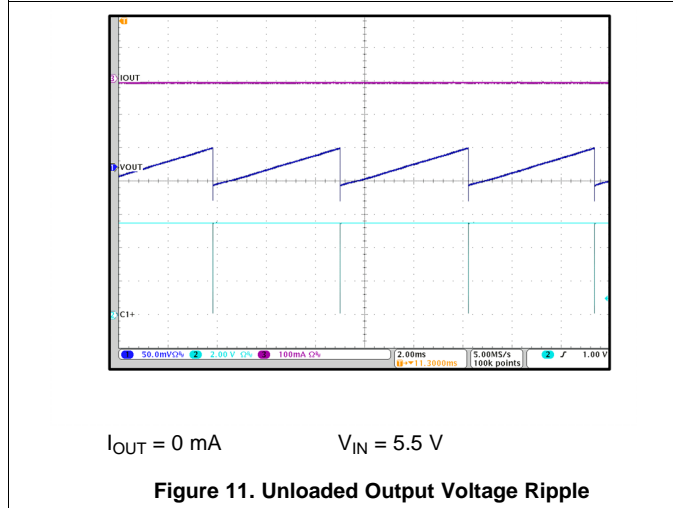
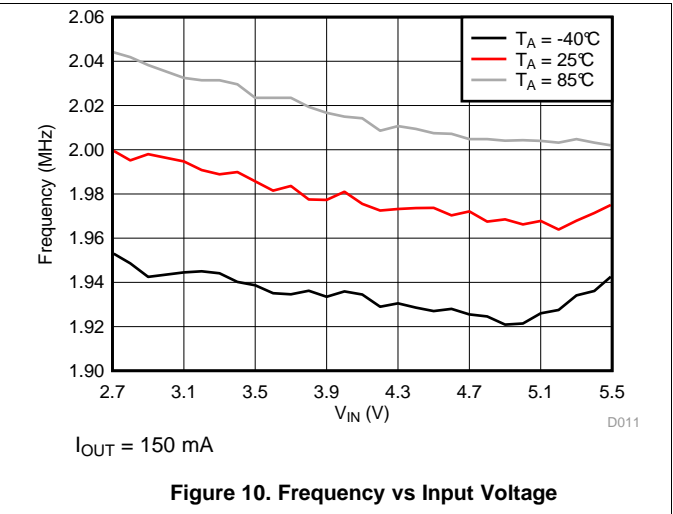
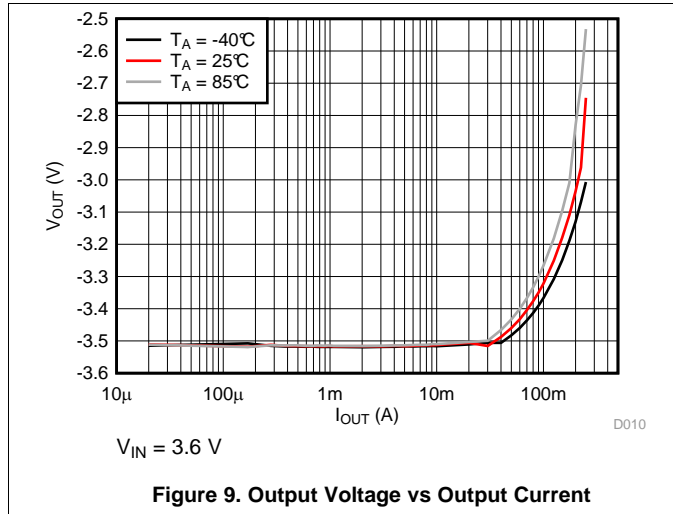

Typical Characteristics (continued)

(典型应用 circuit, $V_{IN} = 3.6\text{ V}$ unless otherwise specified.)

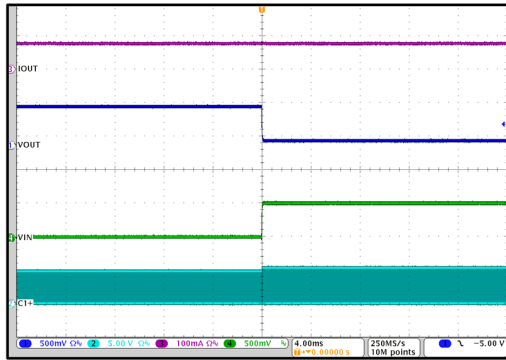

$I_{OUT} = 75\text{ mA}$

Figure 15. Line Step 5.5 V to 5 V

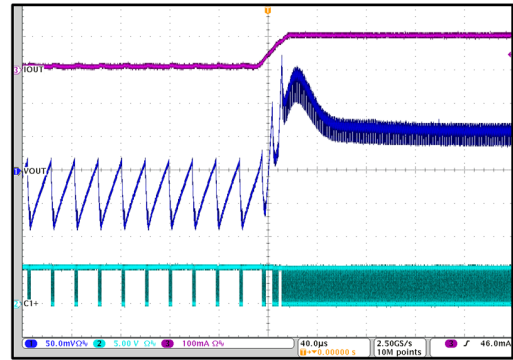

$V_{IN} = 5.5\text{ V}$

Figure 16. Load Step 10 mA to 100 mA

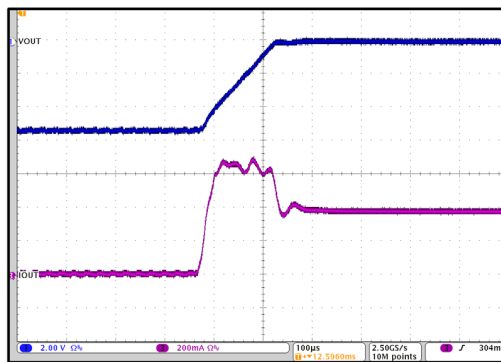

$V_{IN} = 5.5\text{ V}$

Figure 17. Output Short

7 Detailed Description

7.1 Overview

The LM2776 CMOS charge-pump voltage converter inverts a positive voltage in the range of 2.7 V to 5.5 V to the corresponding negative voltage of -2.7 V to -5.5 V. The LM2776 uses three low-cost capacitors to provide up to 200 mA of output current.

7.2 Functional Block Diagram

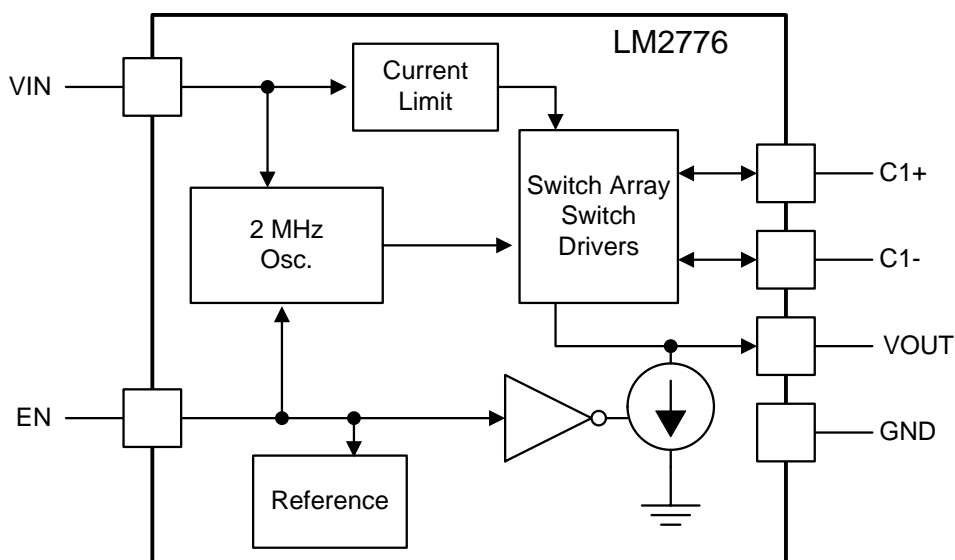

7.3 Feature Description

7.3.1 Input Current Limit

The LM2776 contains current limit circuitry that protects the device in the event of excessive input current and/or output shorts to ground. The input current is limited to 400 mA (typical at $V_{IN} = 5.5$ V) when the output is shorted directly to ground. When the LM2776 is current limiting, power dissipation in the device is likely to be quite high. In this event, thermal cycling is expected.

7.3.2 PFM Operation

To minimize quiescent current during light load operation, the LM2776 allows PFM or pulse-skipping operation. By allowing the charge pump to switch less when the output current is less than 40 mA, the quiescent current drawn from the power source is minimized. The frequency of pulsed operation is not limited and can drop into the sub-1-kHz range when unloaded. As the load increases, the frequency of pulsing increases until it transitions to constant frequency. The fundamental switching frequency of the LM2776 is 2 MHz.

7.3.3 Output Discharge

In shutdown, the LM2776 actively pulls down on the output of the device until the output voltage reaches GND. In this mode, the current drawn from the output is approximately 1.85 mA.

7.3.4 Thermal Shutdown

The LM2776 implements a thermal shutdown mechanism to protect the device from damage due to overheating. When the junction temperature rises to 150°C (typical), the part switches into shutdown mode. The LM2776 releases thermal shutdown when the junction temperature of the part is reduced to 130°C (typical).

Feature Description (continued)

Thermal shutdown is most often triggered by self-heating, which occurs when there is excessive power dissipation in the device and/or insufficient thermal dissipation. LM2776 power dissipation increases with increased output current and input voltage. When self-heating brings on thermal shutdown, thermal cycling is the typical result. Thermal cycling is the repeating process where the part self-heats, enters thermal shutdown (where internal power dissipation is practically zero), cools, turns on, and then heats up again to the thermal shutdown threshold. Thermal cycling is recognized by a pulsing output voltage and can be stopped by reducing the internal power dissipation (reduce input voltage and/or output current) or the ambient temperature. If thermal cycling occurs under desired operating conditions, thermal dissipation performance must be improved to accommodate the power dissipation of the LM2776.

7.3.5 Undervoltage Lockout

The LM2776 has an internal comparator that monitors the voltage at V_{IN} and forces the device into shutdown if the input voltage drops to 2.4 V. If the input voltage rises above 2.6 V, the LM2776 resumes normal operation.

7.4 Device Functional Modes

7.4.1 Shutdown Mode

An enable pin (EN) pin is available to disable the device and place the LM2776 into shutdown mode reducing the quiescent current to 1 μ A. In shutdown, the output of the LM2776 is pulled to ground by an internal pullup current source (approx 1.85 mA).

7.4.2 Enable Mode

Applying a voltage greater than 1.2 V to the EN pin places the device into enable mode. When unloaded, the input current during operation is 120 μ A. As the load current increases, so does the quiescent current. When enabled, the output voltage is equal to the inverse of the input voltage minus the voltage drop across the charge pump.

8 Application and Implementation

NOTE

Information in the following applications sections is not part of the TI component specification, and TI does not warrant its accuracy or completeness. TI's customers are responsible for determining suitability of components for their purposes. Customers should validate and test their design implementation to confirm system functionality.

8.1 Application Information

The LM2776 CMOS charge-pump voltage converter inverts a positive voltage in the range of 2.7 V to 5.5 V to the corresponding negative voltage of -2.7 V to -5.5 V. The device uses three low-cost capacitors to provide up to 200 mA of output current. The LM2776 operates at 2-MHz oscillator frequency to reduce output resistance and voltage ripple under heavy loads. With an operating current of only 100 μ A (operating efficiency greater than 91% with most loads) and 1- μ A typical shutdown current, the LM2776 provides ideal performance for battery-powered systems.

8.2 Typical Application - Voltage Inverter

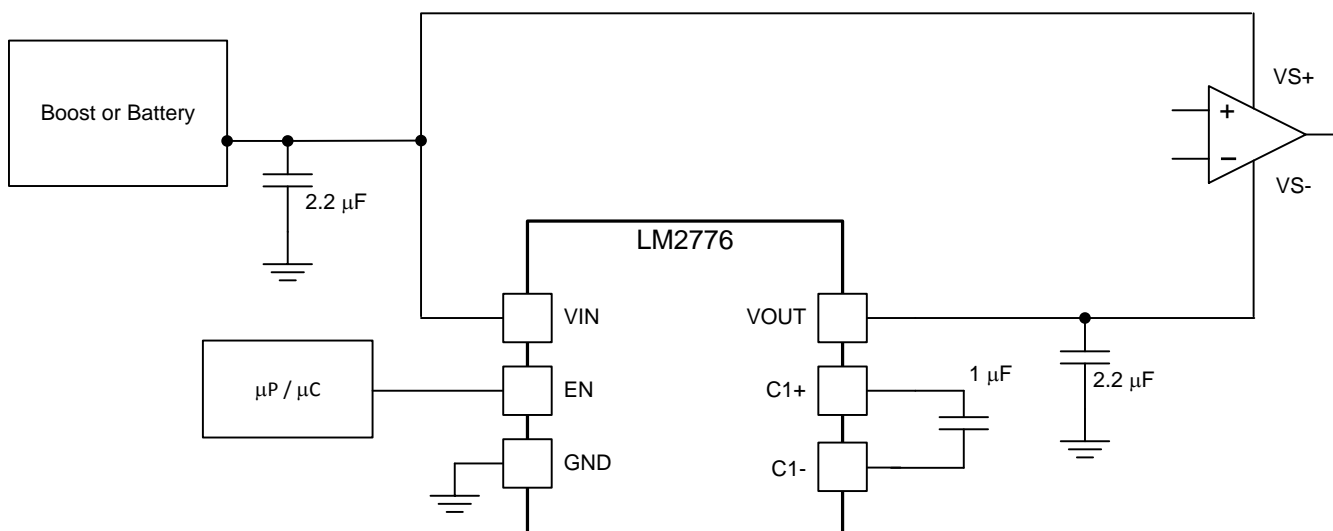

Figure 18. Voltage Inverter

8.2.1 Design Requirements

Example requirements for typical voltage inverter applications:

DESIGN PARAMETER	EXAMPLE VALUE
Input voltage range	2.7 V to 5.5 V
Output current	0 mA to 200 mA
Boost switching frequency	2 MHz

8.2.2 Detailed Design Requirements

The main application of LM2776 is to generate a negative supply voltage. The voltage inverter circuit uses only three external capacitors with an range of the input supply voltage from 2.7 V to 5.5 V.

The LM2776 contains four large CMOS switches which are switched in a sequence to invert the input supply voltage. Energy transfer and storage are provided by external capacitors. Figure 19 shows the voltage conversion scheme. When S_1 and S_3 are closed, C_1 charges to the supply voltage V_{IN} . During this time interval, switches S_2 and S_4 are open. In the second time interval, S_1 and S_3 are open; at the same time, S_2 and S_4 are closed, C_1 is charging C_2 . After a number of cycles, the voltage across C_2 is pumped to V_{IN} . Because the anode of C_2 is connected to ground, the output at the cathode of C_2 equals $-(V_{IN})$ when there is no load current. The output voltage drop when a load is added is determined by the parasitic resistance ($R_{ds(on)}$) of the MOSFET switches and the equivalent series resistance (ESR) of the capacitors) and the charge transfer loss between capacitors.

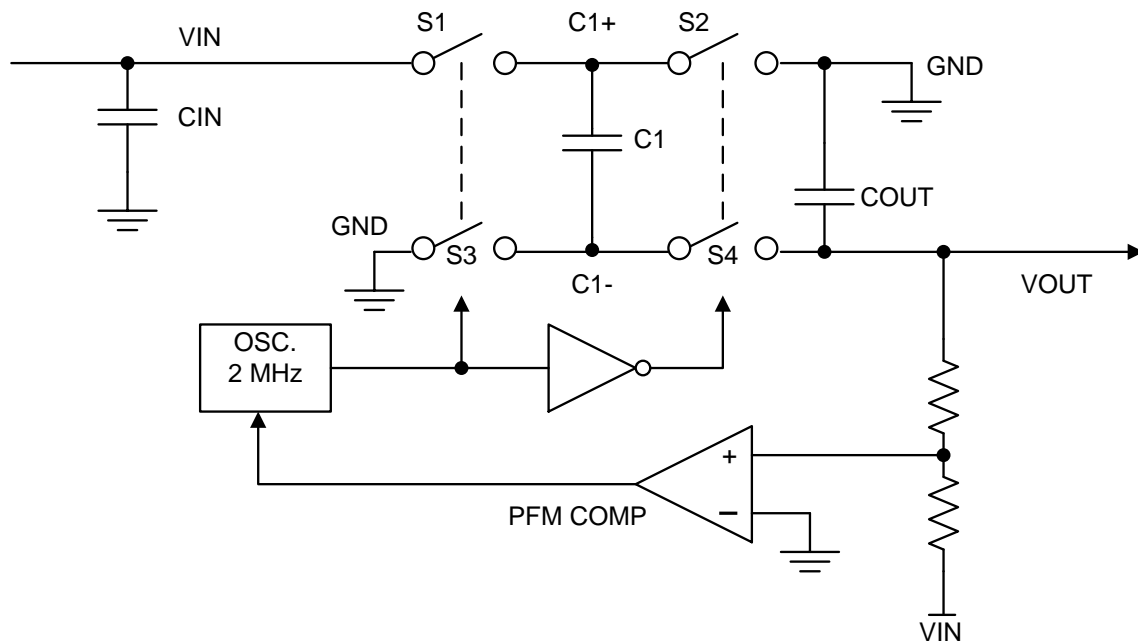

Figure 19. Voltage Inverting Principle

The output characteristics of this circuit can be approximated by an ideal voltage source in series with a resistance. The voltage source equals $-(V_{IN})$. The output resistance R_{OUT} is a function of the ON resistance of the internal MOSFET switches, the oscillator frequency, the capacitance and ESR of C_1 and C_2 . Because the switching current charging and discharging C_1 is approximately twice as the output current, the effect of the ESR of the pumping capacitor C_1 is multiplied by four in the output resistance. The output capacitor C_2 is charging and discharging at a current approximately equal to the output current, therefore, its ESR only counts once in the output resistance. A good approximation of R_{OUT} is:

$$R_{OUT} = (2 \times R_{SW}) + [1 / (f_{SW} \times C)] + (4 \times ESR_{C1}) + ESR_{COUT}$$

where

- R_{SW} is the sum of the ON resistance of the internal MOSFET switches shown in Figure 19. (1)

High-capacitance, low-ESR ceramic capacitors reduce the output resistance.

8.2.2.1 Efficiency

Charge-pump efficiency is defined as

$$\text{Efficiency} = [(V_{OUT} \times I_{OUT}) / \{V_{IN} \times (I_{IN} + I_Q)\}]$$

where

- $I_Q (V_{IN})$ is the quiescent power loss of the device. (2)

8.2.2.2 Power Dissipation

LM2776 power dissipation (P_D) is calculated simply by subtracting output power from input power:

$$P_D = P_{IN} - P_{OUT} = [V_{IN} \times (-I_{OUT} + I_Q)] - [V_{OUT} \times I_{OUT}] \quad (3)$$

Power dissipation increases with increased input voltage and output current. Internal power dissipation self-heats the device. Dissipating this amount power/heat so the LM2776 does not overheat is a demanding thermal requirement for a small surface-mount package. When soldered to a PCB with layout conducive to power dissipation, the thermal properties of the SOT package enable this power to be dissipated from the LM2776 with little or no derating, even when the circuit is placed in elevated ambient temperatures when the output current is 200 mA or less.

8.2.2.3 Capacitor Selection

The LM2776 requires 3 external capacitors for proper operation. TI recommends surface-mount multi-layer ceramic capacitors. These capacitors are small, inexpensive, and have very low ESR ($\leq 15 \text{ m}\Omega$ typical). Tantalum capacitors, OS-CON capacitors, and aluminum electrolytic capacitors generally are not recommended for use with the LM2776 due to their high ESR, as compared to ceramic capacitors.

For most applications, ceramic capacitors with an X7R or X5R temperature characteristic are preferred for use with the LM2776. These capacitors have tight capacitance tolerance (as good as $\pm 10\%$) and hold their value over temperature (X7R: $\pm 15\%$ over -55°C to 125°C ; X5R: $\pm 15\%$ over -55°C to 85°C).

Capacitors with a Y5V or Z5U temperature characteristic are generally not recommended for use with the LM2776. These types of capacitors typically have wide capacitance tolerance (80%, ...20%) and vary significantly over temperature (Y5V: 22%, -82% over -30°C to 85°C range; Z5U: 22%, -56% over 10°C to 85°C range). Under some conditions, a 1- μF -rated Y5V or Z5U capacitor could have a capacitance as low as 0.1 μF . Such detrimental deviation is likely to cause Y5V and Z5U capacitors to fail to meet the minimum capacitance requirements of the LM2776.

Net capacitance of a ceramic capacitor decreases with increased DC bias. This degradation can result in lower capacitance than expected on the input and/or output, resulting in higher ripple voltages and currents. Using capacitors at DC bias voltages significantly below the capacitor voltage rating usually minimizes DC bias effects. Consult capacitor manufacturers for information on capacitor DC bias characteristics.

Capacitance characteristics can vary quite dramatically with different application conditions, capacitor types, and capacitor manufacturers. It is strongly recommended that the LM2776 circuit be thoroughly evaluated early in the design-in process with the mass-production capacitors of choice. This helps ensure that any such variability in capacitance does not negatively impact circuit performance.

The voltage rating of the output capacitor must be 10 V or more. For example, a 10-V 0603 1- μF is acceptable for use with the LM2776, as long as the capacitance does not fall below a minimum of 0.5 μF in the intended application. All other capacitors must have a voltage rating at or above the maximum input voltage of the application. Select the capacitors such that the capacitance on the input does not fall below 0.7 μF , and the capacitance of the flying capacitor does not fall below 0.2 μF .

8.2.2.4 Output Capacitor and Output Voltage Ripple

The peak-to-peak output voltage ripple is determined by the oscillator frequency, the capacitance and ESR of the output capacitor C_{OUT} :

$$V_{RIPPLE} = [(2 \times I_{LOAD}) / (f_{SW} \times C_{OUT})] + (2 \times I_{LOAD} \times ESR_{C_{OUT}}) \quad (4)$$

In typical applications, a 1- μF low-ESR ceramic output capacitor is recommended. Different output capacitance values can be used to reduce ripple shrink the solution size, and/or cut the cost of the solution. But changing the output capacitor may also require changing the flying capacitor and/or input capacitor to maintain good overall circuit performance.

NOTE

In high-current applications, TI recommends a 10- μ F, 10-V low-ESR ceramic output capacitor. If a small output capacitor is used, the output ripple can become large during the transition between PFM mode and constant switching. To prevent toggling, a 2- μ F capacitance is recommended. For example, a 10- μ F, 10-V output capacitor in a 0402 case size typically only has 2- μ F capacitance when biased to 5 V.

High ESR in the output capacitor increases output voltage ripple. If a ceramic capacitor is used at the output, this is usually not a concern because the ESR of a ceramic capacitor is typically very low and has only a minimal impact on ripple magnitudes. If a different capacitor type with higher ESR is used (tantalum, for example), the ESR could result in high ripple. To eliminate this effect, the net output ESR can be significantly reduced by placing a low-ESR ceramic capacitor in parallel with the primary output capacitor. The low ESR of the ceramic capacitor is in parallel with the higher ESR, resulting in a low net ESR based on the principles of parallel resistance reduction.

8.2.2.5 Input Capacitor

The input capacitor (C_{IN}) is a reservoir of charge that aids a quick transfer of charge from the supply to the flying capacitors during the charge phase of operation. The input capacitor helps to keep the input voltage from drooping at the start of the charge phase when the flying capacitors are connected to the input. It also filters noise on the input pin, keeping this noise out of sensitive internal analog circuitry that is biased off the input line.

Much like the relationship between the output capacitance and output voltage ripple, input capacitance has a dominant and first-order effect on input ripple magnitude. Increasing (decreasing) the input capacitance results in a proportional decrease (increase) in input voltage ripple. Input voltage, output current, and flying capacitance also affects input ripple levels to some degree.

In typical applications, a 1- μ F low-ESR ceramic capacitor is recommended on the input. When operating near the maximum load of 200 mA, a minimum recommended input capacitance after taking into the DC-bias derating is 2 μ F or larger. Different input capacitance values can be used to reduce ripple, shrink the solution size, and/or cut the cost of the solution.

8.2.2.6 Flying Capacitor

The flying capacitor (C_1) transfers charge from the input to the output. Flying capacitance can impact both output current capability and ripple magnitudes. If flying capacitance is too small, the LM2776 may not be able to regulate the output voltage when load currents are high. On the other hand, if the flying capacitance is too large, the flying capacitor might overwhelm the input and output capacitors, resulting in increased input and output ripple.

In typical high-current applications, TI recommends 0.47- μ F or 1- μ F 10 V low-ESR ceramic capacitors for the flying capacitors. Polarized capacitors (tantalum, aluminum electrolytic, etc.) must not be used for the flying capacitor, as they could become reverse-biased during LM2776 operation.

8.2.3 Application Curve

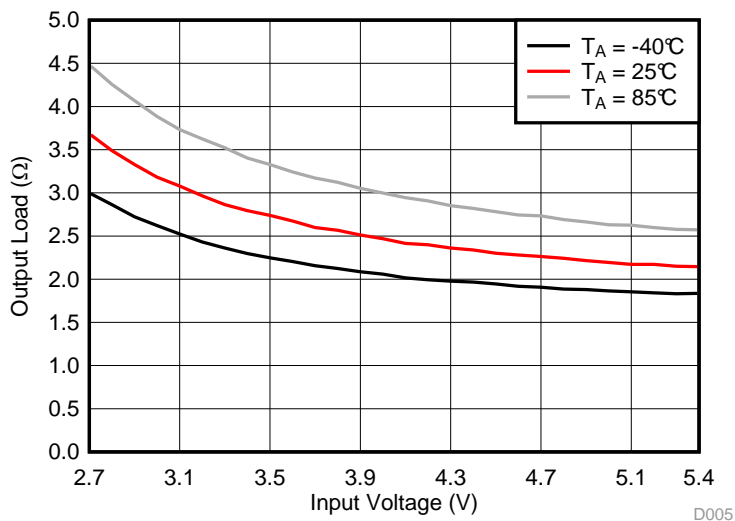

Figure 20. Output Impedance vs Input Voltage

9 Power Supply Recommendations

The LM2776 is designed to operate from an input voltage supply range from 2.7 V to 5.5 V. This input supply must be well regulated and capable to supply the required input current. If the input supply is located far from the LM2776 additional bulk capacitance may be required in addition to the ceramic bypass capacitors.

10 Layout

10.1 Layout Guidelines

The high switching frequency and large switching currents of the LM2776 make the choice of layout important. Use the following steps as a reference to ensure the device is stable and maintains proper LED current regulation across its intended operating voltage and current range:

- Place C_{IN} on the top layer (same layer as the LM2776) and as close to the device as possible. Connecting the input capacitor through short, wide traces to both the VIN and GND pins reduces the inductive voltage spikes that occur during switching which can corrupt the VIN line.
- Place C_{OUT} on the top layer (same layer as the LM2776) and as close to the VOUT and GND pins as possible. The returns for both C_{IN} and C_{OUT} must come together at one point, as close to the GND pin as possible. Connecting C_{OUT} through short, wide traces reduce the series inductance on the VOUT and GND pins that can corrupt the V_{OUT} and GND lines and cause excessive noise in the device and surrounding circuitry.
- Place C1 on the top layer (same layer as the LM2776) and as close to the device as possible. Connect the flying capacitor through short, wide traces to both the C1+ and C1– pins.

10.2 Layout Example

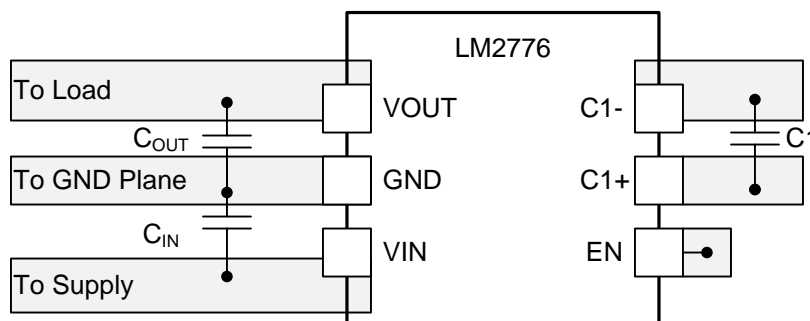

Figure 21. LM2776 Layout Example

11 器件和文档支持

11.1 器件支持

11.1.1 Third-Party Products Disclaimer

TI'S PUBLICATION OF INFORMATION REGARDING THIRD-PARTY PRODUCTS OR SERVICES DOES NOT CONSTITUTE AN ENDORSEMENT REGARDING THE SUITABILITY OF SUCH PRODUCTS OR SERVICES OR A WARRANTY, REPRESENTATION OR ENDORSEMENT OF SUCH PRODUCTS OR SERVICES, EITHER ALONE OR IN COMBINATION WITH ANY TI PRODUCT OR SERVICE.

11.2 接收文档更新通知

要接收文档更新通知，请导航至德州仪器 TI.com.cn 上的器件产品文件夹。请单击右上角的 *通知我* 进行注册，即可收到任意产品信息更改每周摘要。有关更改的详细信息，请查看任意已修订文档中包含的修订历史记录。

11.3 社区资源

下列链接提供到 TI 社区资源的连接。链接的内容由各个分销商“按照原样”提供。这些内容并不构成 TI 技术规范，并且不一定反映 TI 的观点；请参阅 TI 的 [《使用条款》](#)。

TI E2E™ 在线社区 *TI 的工程师对工程师 (E2E) 社区*。此社区的创建目的在于促进工程师之间的协作。在 e2e.ti.com 中，您可以咨询问题、分享知识、拓展思路并与同行工程师一道帮助解决问题。

设计支持 *TI 参考设计支持* 可帮助您快速查找有帮助的 E2E 论坛、设计支持工具以及技术支持的联系信息。

11.4 商标

E2E is a trademark of Texas Instruments.
All other trademarks are the property of their respective owners.

11.5 静电放电警告



这些装置包含有限的内置 ESD 保护。存储或装卸时，应将导线一起截短或将装置放置于导电泡棉中，以防止 MOS 门极遭受静电损伤。

11.6 Glossary

SLYZ022 — *TI Glossary*.

This glossary lists and explains terms, acronyms, and definitions.

12 机械、封装和可订购信息

以下页面包括机械、封装和可订购信息。这些信息是指定器件的最新可用数据。这些数据发生变化时，我们可能不会另行通知或修订此文档。如欲获取此产品说明书的浏览器版本，请参阅左侧的导航栏。

PACKAGING INFORMATION

Orderable part number	Status (1)	Material type (2)	Package Pins	Package qty Carrier	RoHS (3)	Lead finish/ Ball material (4)	MSL rating/ Peak reflow (5)	Op temp (°C)	Part marking (6)
LM2776DBVR	Active	Production	SOT-23 (DBV) 6	3000 LARGE T&R	Yes	SN	Level-1-260C-UNLIM	-40 to 85	2776
LM2776DBVR.A	Active	Production	SOT-23 (DBV) 6	3000 LARGE T&R	Yes	SN	Level-1-260C-UNLIM	-40 to 125	2776
LM2776DBVT	Active	Production	SOT-23 (DBV) 6	250 SMALL T&R	Yes	NIPDAU SN	Level-1-260C-UNLIM	-40 to 85	2776
LM2776DBVT.A	Active	Production	SOT-23 (DBV) 6	250 SMALL T&R	Yes	NIPDAU	Level-1-260C-UNLIM	-40 to 125	2776

⁽¹⁾ **Status:** For more details on status, see our [product life cycle](#).

⁽²⁾ **Material type:** When designated, preproduction parts are prototypes/experimental devices, and are not yet approved or released for full production. Testing and final process, including without limitation quality assurance, reliability performance testing, and/or process qualification, may not yet be complete, and this item is subject to further changes or possible discontinuation. If available for ordering, purchases will be subject to an additional waiver at checkout, and are intended for early internal evaluation purposes only. These items are sold without warranties of any kind.

⁽³⁾ **RoHS values:** Yes, No, RoHS Exempt. See the [TI RoHS Statement](#) for additional information and value definition.

⁽⁴⁾ **Lead finish/Ball material:** Parts may have multiple material finish options. Finish options are separated by a vertical ruled line. Lead finish/Ball material values may wrap to two lines if the finish value exceeds the maximum column width.

⁽⁵⁾ **MSL rating/Peak reflow:** The moisture sensitivity level ratings and peak solder (reflow) temperatures. In the event that a part has multiple moisture sensitivity ratings, only the lowest level per JEDEC standards is shown. Refer to the shipping label for the actual reflow temperature that will be used to mount the part to the printed circuit board.

⁽⁶⁾ **Part marking:** There may be an additional marking, which relates to the logo, the lot trace code information, or the environmental category of the part.

Multiple part markings will be inside parentheses. Only one part marking contained in parentheses and separated by a "~" will appear on a part. If a line is indented then it is a continuation of the previous line and the two combined represent the entire part marking for that device.

Important Information and Disclaimer: The information provided on this page represents TI's knowledge and belief as of the date that it is provided. TI bases its knowledge and belief on information provided by third parties, and makes no representation or warranty as to the accuracy of such information. Efforts are underway to better integrate information from third parties. TI has taken and continues to take reasonable steps to provide representative and accurate information but may not have conducted destructive testing or chemical analysis on incoming materials and chemicals. TI and TI suppliers consider certain information to be proprietary, and thus CAS numbers and other limited information may not be available for release.

In no event shall TI's liability arising out of such information exceed the total purchase price of the TI part(s) at issue in this document sold by TI to Customer on an annual basis.

TAPE AND REEL INFORMATION

QUADRANT ASSIGNMENTS FOR PIN 1 ORIENTATION IN TAPE

*All dimensions are nominal

Device	Package Type	Package Drawing	Pins	SPQ	Reel Diameter (mm)	Reel Width W1 (mm)	A0 (mm)	B0 (mm)	K0 (mm)	P1 (mm)	W (mm)	Pin1 Quadrant
LM2776DBVR	SOT-23	DBV	6	3000	180.0	8.4	3.2	3.2	1.4	4.0	8.0	Q3
LM2776DBVR	SOT-23	DBV	6	3000	178.0	9.0	3.23	3.17	1.37	4.0	8.0	Q3
LM2776DBVT	SOT-23	DBV	6	250	180.0	8.4	3.2	3.2	1.4	4.0	8.0	Q3
LM2776DBVT	SOT-23	DBV	6	250	180.0	8.4	3.2	3.2	1.4	4.0	8.0	Q3

TAPE AND REEL BOX DIMENSIONS

*All dimensions are nominal

Device	Package Type	Package Drawing	Pins	SPQ	Length (mm)	Width (mm)	Height (mm)
LM2776DBVR	SOT-23	DBV	6	3000	210.0	185.0	35.0
LM2776DBVR	SOT-23	DBV	6	3000	180.0	180.0	18.0
LM2776DBVT	SOT-23	DBV	6	250	210.0	185.0	35.0
LM2776DBVT	SOT-23	DBV	6	250	210.0	185.0	35.0



DBV0006A

PACKAGE OUTLINE

SOT-23 - 1.45 mm max height

SMALL OUTLINE TRANSISTOR

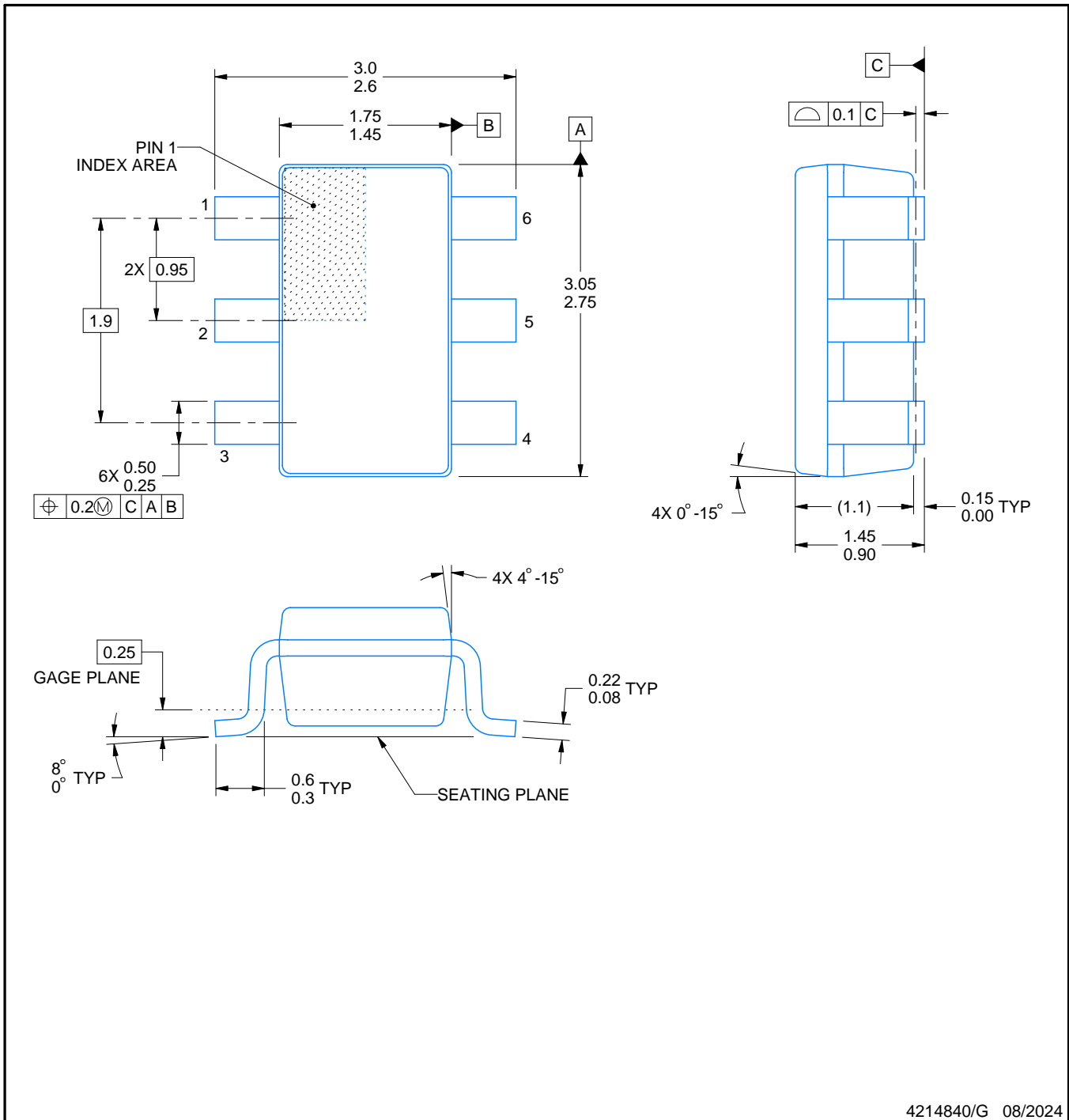

4214840/G 08/2024

NOTES:

1. All linear dimensions are in millimeters. Any dimensions in parenthesis are for reference only. Dimensioning and tolerancing per ASME Y14.5M.
2. This drawing is subject to change without notice.
3. Body dimensions do not include mold flash or protrusion. Mold flash and protrusion shall not exceed 0.25 per side.
4. Leads 1,2,3 may be wider than leads 4,5,6 for package orientation.
5. Reference JEDEC MO-178.

EXAMPLE BOARD LAYOUT

DBV0006A

SOT-23 - 1.45 mm max height

SMALL OUTLINE TRANSISTOR

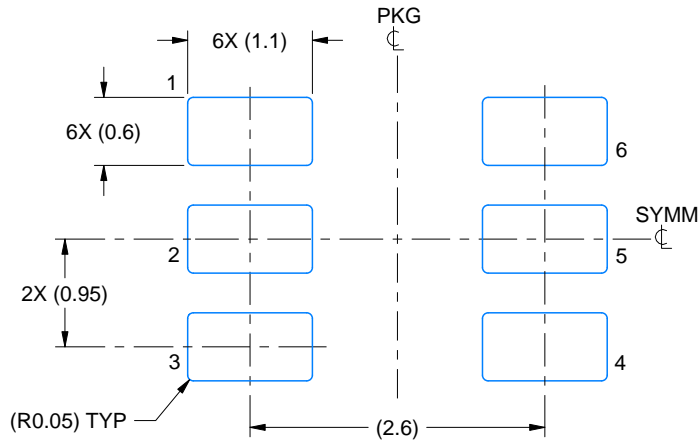

LAND PATTERN EXAMPLE
EXPOSED METAL SHOWN
SCALE:15X



SOLDER MASK DETAILS

4214840/G 08/2024

NOTES: (continued)

- 6. Publication IPC-7351 may have alternate designs.
- 7. Solder mask tolerances between and around signal pads can vary based on board fabrication site.

EXAMPLE STENCIL DESIGN

DBV0006A

SOT-23 - 1.45 mm max height

SMALL OUTLINE TRANSISTOR

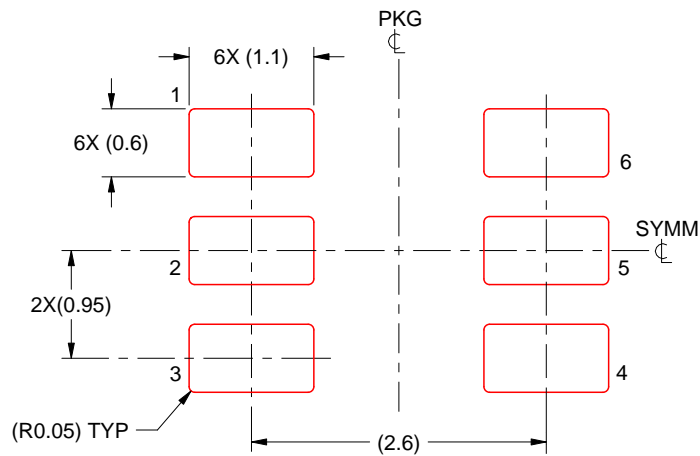

SOLDER PASTE EXAMPLE
BASED ON 0.125 mm THICK STENCIL
SCALE:15X

4214840/G 08/2024

NOTES: (continued)

8. Laser cutting apertures with trapezoidal walls and rounded corners may offer better paste release. IPC-7525 may have alternate design recommendations.
9. Board assembly site may have different recommendations for stencil design.

重要通知和免责声明

TI“按原样”提供技术和可靠性数据（包括数据表）、设计资源（包括参考设计）、应用或其他设计建议、网络工具、安全信息和其他资源，不保证没有瑕疵且不做任何明示或暗示的担保，包括但不限于对适销性、与某特定用途的适用性或不侵犯任何第三方知识产权的暗示担保。

这些资源可供使用 TI 产品进行设计的熟练开发人员使用。您将自行承担以下全部责任：(1) 针对您的应用选择合适的 TI 产品，(2) 设计、验证并测试您的应用，(3) 确保您的应用满足相应标准以及任何其他安全、安保法规或其他要求。

这些资源如有变更，恕不另行通知。TI 授权您仅可将这些资源用于研发本资源所述的 TI 产品的相关应用。严禁以其他方式对这些资源进行复制或展示。您无权使用任何其他 TI 知识产权或任何第三方知识产权。对于因您对这些资源的使用而对 TI 及其代表造成的任何索赔、损害、成本、损失和债务，您将全额赔偿，TI 对此概不负责。

TI 提供的产品受 [TI 销售条款](#)、[TI 通用质量指南](#) 或 [ti.com](#) 上其他适用条款或 TI 产品随附的其他适用条款的约束。TI 提供这些资源并不会扩展或以其他方式更改 TI 针对 TI 产品发布的适用的担保或担保免责声明。除非德州仪器 (TI) 明确将某产品指定为定制产品或客户特定产品，否则其产品均为按确定价格收入目录的标准通用器件。

TI 反对并拒绝您可能提出的任何其他或不同的条款。

版权所有 © 2026，德州仪器 (TI) 公司

最后更新日期：2025 年 10 月