

DS280MB810 具有交叉点的低功耗 28Gbps 8 通道线性中继器

1 特性

- 支持高达 28Gbaud NRZ 接口的八通道多协议线性均衡器
- 具有引脚或寄存器控制的集成 2x2 交叉点，适用于多路复用器、扇出和信号交叉应用
- 低功耗：93mW/通道（典型值）
- 无需散热器
- 无缝支持链路协商、自动协商和前向纠错 (FEC) 直通功能的直线均衡
- 频率为 14GHz 时，可将信道范围扩展 17dB+，超出常规 ASIC-to-ASIC 功能
- 超低延迟：100ps（典型值）
- 低附加随机抖动
- 采用集成 RX 交流耦合电容的 8mm x 13mm BGA 小封装，适用于简易直通布线
- 独特引脚可实现在封装下方布置高速信号布线
- 提供交叉点的兼容引脚重定时器
- 2.5V ±5% 单电源
- 工作温度范围：-40°C 至 +85°C

2 应用

- 背板和中板信号分配和均衡
- 实现故障转移冗余的多路复用器和多路信号分离器
- 前端接口眼开口和信号分配，适用于端口之间的转换

3 说明

DS280MB810 是一款超低功耗、高性能八通道线性均衡器，支持数据传输速率高达 28Gbaud NRZ 的多速率、多协议接口。该器件可用于扩展长度范围并提高背板、前端口和芯片间应用的高速串行链路的稳健性。

DS280MB810 在每对相邻通道之间都具有一个完整的 2x2 交叉点开关，支持 2 到 1 多路复用和 1 到 2 多路分解应用，可实现故障转移冗余，以及有助于 PCB 布线的信号交叉。交叉点可通过引脚或 SMBus 寄存器接口进行控制。

DS280MB810 均衡的线性特质保留了发射信号的特性，因此允许主机与链路合作伙伴 ASIC 自由协商发射均衡器系数 (100G-CR4/KR4)。这种链路协商协议的透明管理有助于在对延迟影响最小的情况下实现系统级互操作性。DS280MB810 支持两级脉冲振幅调制 (PAM) 或 NRZ，可在线性工作范围内提供高达 28Gbaud 的符号速率和峰间信号振幅。

每条通道独立运行，并且可以单独配置。在大多数应用场景中，无论数据速率如何，都可以使用相同的配置。

DS280MB810 将小型封装尺寸、经优化的高速信号退出和引脚兼容的重定时器相结合，使其成为高密度背板应用的理想之选。凭借简化的均衡控制、低功耗和超低

附加抖动特性，该器件适用于 100G-SR4/LR4/CR4 等前端接口。8mm x 13mm 小型封装适用于 QSFP、SFP、CFP 和 CDFP 等多种标准前端接口连接器，并且无需散热器。

器件信息(1)

器件型号	封装	封装尺寸 (标称值)
DS280MB810	nFBGA (135)	8.0mm x 13.0mm

(1) 如需了解所有可用封装，请参阅数据表末尾的可订购产品附录。

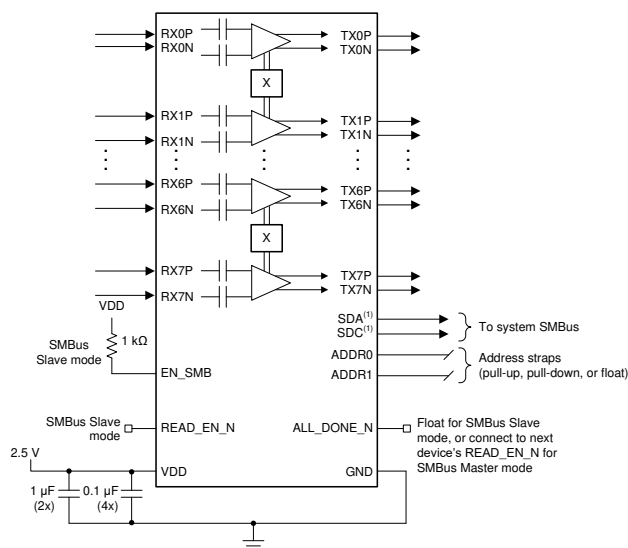

简化原理图

Table of Contents

1 特性	1	8.4 Device Functional Modes.....	18
2 应用	1	8.5 Programming.....	20
3 说明	1	8.6 Register Maps.....	21
4 Revision History	2	9 Application and Implementation	32
5 Description (continued)	3	9.1 Application Information.....	32
6 Pin Configuration and Functions	3	9.2 Typical Application.....	32
7 Specifications	7	9.3 Initialization Set Up.....	43
7.1 Absolute Maximum Ratings.....	7	10 Power Supply Recommendations	43
7.2 ESD Ratings.....	7	11 Layout	45
7.3 Recommended Operating Conditions.....	7	11.1 Layout Guidelines.....	45
7.4 Thermal Information.....	8	11.2 Layout Examples.....	45
7.5 Electrical Characteristics.....	8	12 Device and Documentation Support	48
7.6 Timing Requirements - Serial Management Bus Interface.....	13	12.1 Documentation Support.....	48
7.7 Typical Characteristics.....	14	12.2 Receiving Notification of Documentation Updates..	48
8 Detailed Description	15	12.3 Support Resources.....	48
8.1 Overview.....	15	12.4 Trademarks.....	48
8.2 Functional Block Diagram.....	15	13 Mechanical, Packaging, and Orderable Information	49
8.3 Feature Description.....	16		

4 Revision History

注：以前版本的页码可能与当前版本的页码不同

Changes from Revision B (October 2019) to Revision C (December 2020)	Page
• 更改了数据速率支持，提示仅支持 NRZ.....	1
• 删除了对 PAM4 28 GBd 接口的支持.....	1

Changes from Revision A (September 2017) to Revision B (October 2019)	Page
• 首次公开发布.....	1

5 Description (continued)

Integrated AC coupling capacitors (RX side) eliminate the need for external capacitors on the PCB. The DS280MB810 has a single power supply and minimal need for external components. These features reduce PCB routing complexity and bill of materials (BOM) cost.

A pin-compatible Retimer device with cross-point is available for longer reach applications.

The DS280MB810 can be configured either through the SMBus or through an external EEPROM. Up to 16 devices can share a single EEPROM.

6 Pin Configuration and Functions



图 6-1. Top View

表 6-1. Pin Functions

PIN		I/O	DESCRIPTION
NAME	NO.		
High Speed Differential I/O			
RX0P	C15	Input	Inverting and non-inverting differential inputs to the equalizer. An on-chip 100-Ω termination resistor connects RXP to RXN. These inputs are AC coupled with 220 nF capacitors assembled on the package substrate.
RX0N	B15	Input	
RX1P	B13	Input	Inverting and non-inverting differential inputs to the equalizer. An on-chip 100-Ω termination resistor connects RXP to RXN. These inputs are AC coupled with 220 nF capacitors assembled on the package substrate.
RX1N	A13	Input	
RX2P	B11	Input	Inverting and non-inverting differential inputs to the equalizer. An on-chip 100-Ω termination resistor connects RXP to RXN. These inputs are AC coupled with 220 nF capacitors assembled on the package substrate.
RX2N	A11	Input	
RX3P	B9	Input	Inverting and non-inverting differential inputs to the equalizer. An on-chip 100-Ω termination resistor connects RXP to RXN. These inputs are AC coupled with 220 nF capacitors assembled on the package substrate.
RX3N	A9	Input	
RX4P	B7	Input	Inverting and non-inverting differential inputs to the equalizer. An on-chip 100-Ω termination resistor connects RXP to RXN. These inputs are AC coupled with 220 nF capacitors assembled on the package substrate.
RX4N	A7	Input	

表 6-1. Pin Functions (continued)

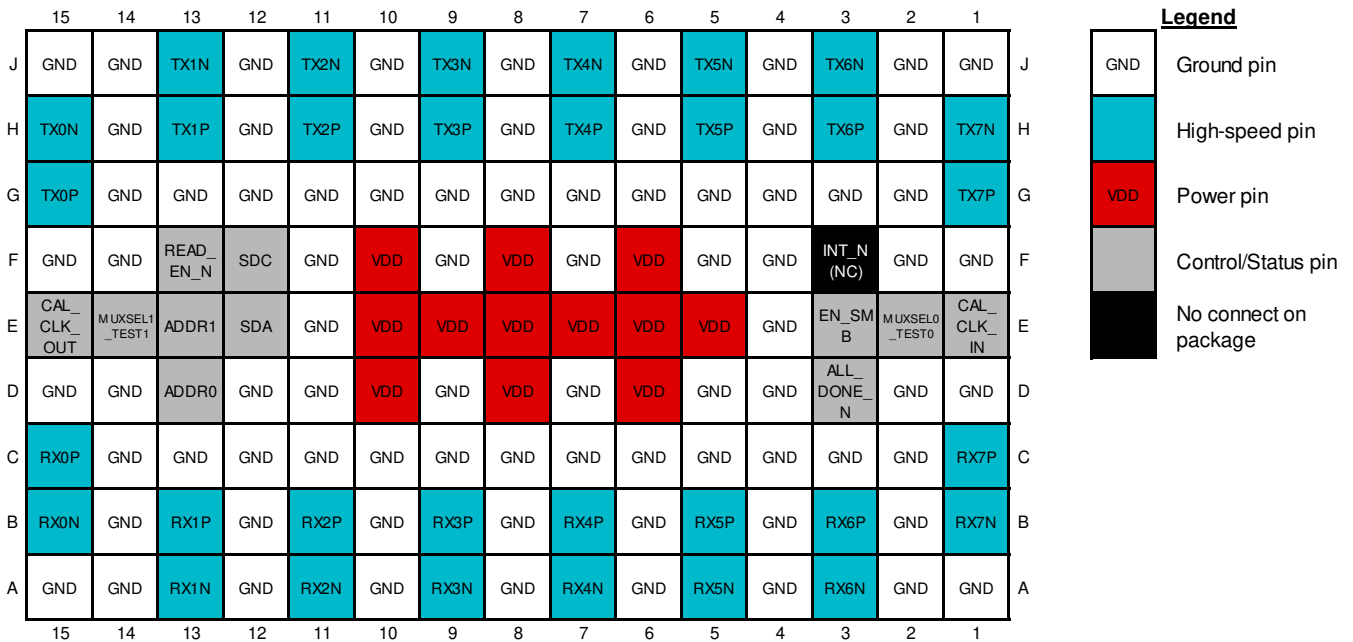
PIN		I/O	DESCRIPTION
NAME	NO.		
RX5P	B5	Input	Inverting and non-inverting differential inputs to the equalizer. An on-chip 100- Ω termination resistor connects RXP to RXN. These inputs are AC coupled with 220 nF capacitors assembled on the package substrate.
RX5N	A5	Input	
RX6P	B3	Input	Inverting and non-inverting differential inputs to the equalizer. An on-chip 100- Ω termination resistor connects RXP to RXN. These inputs are AC coupled with 220 nF capacitors assembled on the package substrate.
RX6N	A3	Input	
RX7P	C1	Input	Inverting and non-inverting differential inputs to the equalizer. An on-chip 100- Ω termination resistor connects RXP to RXN. These inputs are AC coupled with 220 nF capacitors assembled on the package substrate.
RX7N	B1	Input	
TX0P	G15	Output	Inverting and non-inverting 50- Ω driver outputs. Compatible with AC-coupled differential inputs.
TX0N	H15	Output	
TX1P	H13	Output	Inverting and non-inverting 50- Ω driver outputs. Compatible with AC-coupled differential inputs.
TX1N	J13	Output	
TX2P	H11	Output	Inverting and non-inverting 50- Ω driver outputs. Compatible with AC-coupled differential inputs.
TX2N	J11	Output	
TX3P	H9	Output	Inverting and non-inverting 50- Ω driver outputs. Compatible with AC-coupled differential inputs.
TX3N	J9	Output	
TX4P	H7	Output	Inverting and non-inverting 50- Ω driver outputs. Compatible with AC-coupled differential inputs.
TX4N	J7	Output	
TX5P	H5	Output	Inverting and non-inverting 50- Ω driver outputs. Compatible with AC-coupled differential inputs.
TX5N	J5	Output	
TX6P	H3	Output	Inverting and non-inverting 50- Ω driver outputs. Compatible with AC-coupled differential inputs.
TX6N	J3	Output	
TX7P	G1	Output	Inverting and non-inverting 50- Ω driver outputs. Compatible with AC-coupled differential inputs.
TX7N	H1	Output	
Calibration Clock Pins (For Supporting Upgrade Path to Pin-Compatible Retimer Device)			
CAL_CLK_IN	E1	Input	25-MHz (± 100 PPM) 2.5-V single-ended clock from external oscillator. No stringent phase noise or jitter requirements on this clock. A 25-MHz input clock is only required if there is a need to support a future upgrade to the pin-compatible Retimer device. If there is no need to support a future upgrade to a pin-compatible Retimer device, then a 25-MHz clock is not required. This input pin has a weak active pull down and can be left floating if the CAL_CLK feature is not required.
CAL_CLK_OUT	E15	Output	2.5-V buffered replica of calibration clock input (pin E1) for connecting multiple devices in a daisy-chained fashion.
System Management Bus (SMBus) Pins			
ADDR0	D13	Input, 4-Level	4-level strap pins used to set the SMBus address of the device. The pin state is read on power-up. The multi-level nature of these pins allows for 16 unique device addresses, see 表 8-1. The four strap options include: 0: 1 k Ω to GND R: 10 k Ω to GND F: Float 1: 1 k Ω to VDD
ADDR1	E13	Input, 4-Level	
EN_SMB	E3	Input, 4-Level	4-level 2.5-V input used to select between SMBus master mode (float) and SMBus slave mode (high). The four defined levels are: 0: 1 k Ω to GND - RESERVED R: 10 k Ω to GND - RESERVED, TI test mode F: Float - SMBus master mode 1: 1 k Ω to VDD - SMBus slave mode
SDA	E12	I/O, 3.3 V LVCMOS, Open Drain	SMBus data input or open drain output. External 2-k Ω to 5-k Ω pull-up resistor is required. This pin is 3.3-V LVCMOS tolerant.

表 6-1. Pin Functions (continued)

PIN		I/O	DESCRIPTION
NAME	NO.		
SDC	F12	I/O, 3.3 V LVCMOS, Open Drain	SMBus clock input or open drain clock output. External 2-k Ω to 5-k Ω pull-up resistor is required. This pin is 3.3-V LVCMOS tolerant.
READ_EN_N	F13	Input, 3.3 V LVCMOS	SMBus master mode (EN_SMB = Float): When asserted low, initiates the SMBus master mode EEPROM read function. Once EEPROM read is complete (indicated by assertion of ALL_DONE_N low), this pin can be held low for normal device operation. SMBus slave mode (EN_SMB = 1 k Ω to VDD): When asserted low, this causes the device to be held in reset (SMBus state machine reset and register reset). This pin should be pulled high or left floating for normal operation in SMBus slave mode. This pin has an internal weak pull-up and is 3.3-V LVCMOS tolerant.
ALL_DONE_N	D3	Output, LVCMOS	Indicates the completion of a valid EEPROM register load operation when in SMBus master mode (EN_SMB = Float): High = External EEPROM load failed or incomplete. Low = External EEPROM load successful and complete. When in SMBus slave mode (EN_SMB = 1 k Ω to VDD), this output will be high-Z until READ_EN_N is driven low, at which point ALL_DONE_N will be driven low. This behavior allows the reset signal connected to READ_EN_N of one device to propagate to the subsequent devices when ALL_DONE_N is connected to READ_EN_N in an SMBus slave mode application.
Miscellaneous Pins			
INT_N	F3	No connect in package	No connect on package. For applications using DS280MB810 and pin-compatible TI Retimers, this pin can be connected to other devices' INT_N pins. This is a recommendation for cases where there is a need to support a potential future upgrade to the pin-compatible Retimer device, which uses this pin as an interrupt signal to a system controller.
MUXSEL0_TEST0	E2	Input, LVCMOS	When operating the cross-point in pin-control mode (Shared Reg_0x05[1]=1), MUXSEL0 controls the cross-point for channels 0 - 1 and 4 - 5, and MUXSEL1 controls the cross-point for channels 2 - 3 and 6 - 7. If these pins are not used for cross-point control, they may be left floating or tied to GND. These pins also serve as TI test pins when in test mode (EN_SMB = 10 k Ω to GND). These pins have an internal weak pull-up.
MUXSEL1_TEST1	E14	Input, LVCMOS	
Power			
VDD	D6, D8, D10, E5, E6, E7, E8, E9, E10, F6, F8, F10	Power	Power supply, VDD = 2.5 V +/- 5%. Use at least six de-coupling capacitors between the Repeater's VDD plane and GND as close to the Repeater as possible. For example, four 0.1- μ F capacitors and two 1- μ F capacitors directly beneath the device or as close to the VDD pins as possible. The VDD pins on this device should be connected through a low-resistance path to the board VDD plane. For more information, see 节 10 .

表 6-1. Pin Functions (continued)

PIN		I/O	DESCRIPTION
NAME	NO.		
GND	A1, A2, A4, A6, A8, A10, A12, A14, A15, B2, B4, B6, B8, B10, B12, B14, C2, C3, C4, C5, C6, C7, C8, C9, C10, C11, C12, C13, C14, D1, D2, D4, D5, D7, D9, D11, D12, D14, D15, E4, E11, F1, F2, F4, F5, F7, F9, F11, F14, F15, G2, G3, G4, G5, G6, G7, G8, G9, G10, G11, G12, G13, G14, H2, H4, H6, H8, H10, H12, H14, J1, J2, J4, J6, J8, J10, J12, J14, J15	Power	Ground reference. The GND pins on this device should be connected through a low-impedance path to the board GND plane.

7 Specifications

7.1 Absolute Maximum Ratings

Over operating free-air temperature range (unless otherwise noted). ⁽¹⁾

		MIN	MAX	UNIT
VDD_ABSMAX	Supply voltage (VDD)	-0.5	2.75	V
VI _{O2.5V,ABS} MAX	2.5 V I/O voltage (LVCMOS and CMOS)	-0.5	2.75	V
VI _{O3.3V,ABS} MAX	Open drain and 3.3 V-tolerance I/O voltage (SDA, SDC, READ_EN_N)	-0.5	4.0	V
VI _{OHS,ABS} MAX	High-speed I/O voltage (RXnP, RXnN, TXnP, TXnN)	-0.5	2.75	V
T _{JABS} MAX	Junction temperature		150	°C
T _{stg}	Storage temperature range	-40	150	°C

- (1) Stresses beyond those listed under Absolute Maximum Ratings may cause permanent damage to the device. These are stress ratings only, which do not imply functional operation of the device at these or any other conditions beyond those indicated under Recommended Operating Conditions. Exposure to absolute-maximum-rated conditions for extended periods may affect device reliability.

7.2 ESD Ratings

		VALUE	UNIT
V _(ESD)	Electrostatic discharge	Human-body model (HBM), per ANSI/ESDA/JEDEC JS-001 ⁽¹⁾	±1500
		Charged-device model (CDM), per JEDEC specification JESD22-C101 ⁽²⁾	±1000

- (1) JEDEC document JEP155 states that 500-V HBM allows safe manufacturing with a standard ESD control process. Pins listed as ±2 kV may actually have higher performance.
(2) JEDEC document JEP157 states that 250-V CDM allows safe manufacturing with a standard ESD control process.

7.3 Recommended Operating Conditions

Over operating free-air temperature range (unless otherwise noted).

			MIN	NOM	MAX	UNIT
VDD	Supply voltage, VDD to GND	DC plus AC power should not exceed these limits	2.375	2.5	2.625	V
N _{VDD}	Supply noise tolerance ⁽¹⁾	Supply noise, DC to <50 Hz, sinusoidal			250	mVpp
		Supply noise, 50 Hz to 10 MHz, sinusoidal			20	mVpp
		Supply noise, >10 MHz, sinusoidal			10	mVpp
T _{RampVDD}	VDD supply ramp time	From 0 V to 2.375 V	150			µs
T _J	Operating junction temperature		-40		110	C
T _A	Operating ambient temperature		-40		85	C
VDD _{SMBUS}	SMBus SDA and SDC Open Drain Termination Voltage	Supply voltage for open drain pull-up resistor			3.6	V
F _{SMBus}	SMBus clock (SDC) frequency in SMBus slave mode				400	kHz

- (1) Sinusoidal noise is superimposed to supply voltage with negligible impact to device function or critical performance shown in the Electrical Table.

7.4 Thermal Information

THERMAL METRIC ⁽¹⁾	CONDITIONS/ASSUMPTIONS ⁽²⁾	DS280MB810	UNIT
		nFBGA	
		135 PINS	
$R_{\theta JA}$ Junction-to-ambient thermal resistance	4-Layer JEDEC Board	45.2	°C/W
	10-Layer 8-in x 6-in Board	26.3	
	20-Layer 8-in x 6-in Board	24.8	
	30-Layer 8-in x 6-in Board	22.7	
$R_{\theta JC(top)}$ Junction-to-case (top) thermal resistance	4-Layer JEDEC Board	26.6	°C/W
$R_{\theta JB}$ Junction-to-board thermal resistance	4-Layer JEDEC Board	25.8	°C/W
Ψ_{JT} Junction-to-top characterization parameter	4-Layer JEDEC Board	13.3	°C/W
	10-Layer 8-in x 6-in Board	13.0	
	20-Layer 8-in x 6-in Board	13.0	
	30-Layer 8-in x 6-in Board	13.0	
Ψ_{JB} Junction-to-board characterization parameter	4-Layer JEDEC Board	22.8	°C/W
	10-Layer 8-in x 6-in Board	21.4	
	20-Layer 8-in x 6-in Board	21.1	
	30-Layer 8-in x 6-in Board	20.8	

- (1) For more information about traditional and new thermal metrics, see the *Semiconductor and IC Package Thermal Metrics* application report, [SPRA953](#).
- (2) No heat sink or airflow was assumed for these estimations. Depending on the application, a heat sink, faster airflow, or reduced ambient temperature (<85 C) may be required in order to meet the maximum junction temperature specification per the [# 7.3](#).

7.5 Electrical Characteristics

Over operating free-air temperature range (unless otherwise noted).

PARAMETER		TEST CONDITIONS	MIN	TYP	MAX	UNIT
POWER						
$W_{channel}$	Power consumption per active channel	Channel enabled with maximum driver VOD (DRV_SEL_VOD = 3). Static power consumption not included.		82	109 ⁽¹⁾	mW
		Channel enabled with minimum driver VOD (DRV_SEL_VOD = 0). Static power consumption not included.		75	100 ⁽¹⁾	mW
$W_{channel_CP}$	Power consumption per active channel, cross-point enabled	Channel enabled, cross-point enabled, and maximum driver VOD (DRV_SEL_VOD = 3). Static power consumption not included.		82	109 ⁽¹⁾	mW
		Channel enabled, cross-point enabled, and minimum driver VOD (DRV_SEL_VOD = 0). Static power consumption not included.		75	100 ⁽¹⁾	mW

Over operating free-air temperature range (unless otherwise noted).

PARAMETER		TEST CONDITIONS	MIN	TYP	MAX	UNIT
W _{channel_FO}	Power consumption per active channel, fanout enabled	Channel enabled, fanout enabled, and maximum driver VOD (DRV_SEL_VOD = 3). Static power consumption not included.		69	95 ⁽¹⁾	mW
		Channel enabled, fanout enabled, and minimum driver VOD (DRV_SEL_VOD = 0). Static power consumption not included.		61	86 ⁽¹⁾	mW
W _{static_total}	Idle (static) mode total device power consumption	Channels disabled and powered down (DRV_PD = 1, EQ_PD = 1).		110	173 ⁽¹⁾	mW
I _{total}	Active mode total device supply current consumption	All channels enabled with maximum driver VOD (DRV_SEL_VOD = 3).		307	389	mA
		All channels enabled with minimum driver VOD (DRV_SEL_VOD = 0).		283	361	mA
I _{total_CP}	Active mode total device supply current consumption, cross-point enabled	All channels enabled, cross-point enabled, and maximum driver VOD (DRV_SEL_VOD = 3).		307	389	mA
		All channels enabled, cross-point enabled, and minimum driver VOD (DRV_SEL_VOD = 0).		283	361	mA
I _{total_FO}	Active mode total device supply current consumption, fanout enabled	All channels enabled, fanout enabled, and maximum driver VOD (DRV_SEL_VOD = 3).		264	346	mA
		All channels enabled, fanout enabled, and minimum driver VOD (DRV_SEL_VOD = 0).		240	318	mA
I _{static_total}	Idle (static) mode total device supply current consumption	All channels disabled and powered down (DRV_PD = 1, EQ_PD = 1).		44	66	mA
LVC MOS DC SPECIFICATIONS (CAL_CLK_IN, CAL_CLK_OUT, READ_EN_N, ALL_DONE_N, MUXSEL[1:0])						
V _{IH}	High level input voltage		1.75		VDD	V
		READ_EN_N pin only	1.75		3.6	V
V _{IL}	Low level input voltage		GND		0.7	V
V _{OH}	High level output voltage	IOH = 4 mA	2			V
V _{OL}	Low level output voltage	IOL = -4 mA			0.4	V
I _{IH}	Input high leakage current	Vinput = VDD, MUXSEL[1:0] pins			16	μA
		Vinput = VDD, CAL_CLK_IN pin			66	μA
		Vinput = VDD, READ_EN_N pin ⁽²⁾			1	μA
I _{IL}	Input low leakage current	Vinput = 0 V, MUXSEL[1:0] pins	-38			μA
		Vinput = 0 V, CAL_CLK_IN pin ⁽³⁾	-1			μA
		Vinput = 0 V, READ_EN_N pin ⁽²⁾	-55			μA
4-LEVEL LOGIC ELECTRICAL SPECIFICATIONS (APPLIES TO 4-LEVEL INPUT CONTROL PINS ADDR0, ADDR1, and EN_SMB)						
I _{IH}	Input high leakage current				105	μA
I _{IL}	Input low leakage current		-253			μA

Over operating free-air temperature range (unless otherwise noted).

PARAMETER		TEST CONDITIONS	MIN	TYP	MAX	UNIT
V _{TH}	High level (1) input voltage			0.95 * VDD		V
	Float level input voltage			0.67 * VDD		V
	10 K to GND input voltage			0.33 * VDD		V
	Low level (0) input voltage			0.1		V
HIGH-SPEED DIFFERENTIAL INPUTS (RXnP, RXnN)						
BST	CTLE high-frequency boost	Measured with maximum CTLE setting and maximum BW setting (EQ_BST1 = 7, EQ_BST2 = 7, EQ_BW = 3). Boost is defined as the gain at 14 GHz relative to 20 MHz.		25.6		dB
		Measured with maximum CTLE setting and maximum BW setting (EQ_BST1 = 7, EQ_BST2 = 7, EQ_BW = 3). Boost is defined as the gain at 12.9 GHz relative to 20 MHz.		25.3		dB
BST	CTLE high-frequency boost	Measured with minimum CTLE setting and minimum BW setting (EQ_BST1 = 0, EQ_BST2 = 0, EQ_BW = 0, EQ_EN_BYPASS = 1). Boost is defined as the gain at 14 GHz relative to 20 MHz.		2.4		dB
		Measured with minimum CTLE setting and minimum BW setting (EQ_BST1 = 0, EQ_BST2 = 0, EQ_BW = 0, EQ_EN_BYPASS = 1). Boost is defined as the gain at 12.9 GHz relative to 20 MHz.		2.4		dB
BST _{delta}	CTLE high-frequency gain variation	Measured with maximum CTLE setting (EQ_BST1 = 7, EQ_BST2 = 7). Gain variation is defined as the total change in gain at 14 GHz due to temperature and voltage variation.		< 3		dB
		Measured with maximum CTLE setting (EQ_BST1 = 7, EQ_BST2 = 7). Gain variation is defined as the total change in gain at 12.9 GHz due to temperature and voltage variation.		< 3		dB
BST _{delta}	CTLE high-frequency gain variation	Measured with minimum CTLE setting (EQ_BST1 = 0, EQ_BST2 = 0, EQ_EN_BYPASS = 1). Gain variation is defined as the total change in gain at 14 GHz due to temperature and voltage variation.		< 2		dB
		Measured with minimum CTLE setting (EQ_BST1 = 0, EQ_BST2 = 0, EQ_EN_BYPASS = 1). Gain variation is defined as the total change in gain at 12.9 GHz due to temperature and voltage variation.		< 2		dB
RL _{SDD11}	Input differential return loss	50 MHz to 3.7 GHz		< -14		dB
		3.7 GHz to 10 GHz		< -12		dB
		10 GHz to 14.1 GHz		< -8		dB
		14.1 GHz to 20 GHz		< -6		dB

Over operating free-air temperature range (unless otherwise noted).

PARAMETER		TEST CONDITIONS	MIN	TYP	MAX	UNIT
RL _{SDC11}	Input differential-to-common-mode return loss	100 MHz to 3.3 GHz		< -35		dB
		3.3 GHz to 12.9 GHz		< -26		dB
		12.9 GHz to 20 GHz		< -22		dB
RL _{SCC11}	Input common-mode return loss	100 MHz to 10 GHz		< -7		dB
		10 GHz to 20 GHz		< -8		dB
V _{SDAT}	AC signal detect assert (ON) differential voltage threshold level	Minimum input peak-to-peak amplitude level at device pins required to assert signal detect. 25.78125 Gbps with PRBS7 pattern and 20 dB loss channel.		196		mVpp
V _{SDDT}	AC signal detect de-assert (OFF) differential voltage threshold level	Maximum input peak-to-peak amplitude level at device pins which causes signal detect to de-assert. 25.78125 Gbps with PRBS7 pattern and 20 dB loss channel.		147		mVpp
VID _{linear}	Input amplitude linear range. The maximum VID for which the repeater remains linear, defined as ≤ 1 dB compression of Vout/Vin.	Measured with the highest wide-band gain setting (EQ_HIGH_GAIN = 1, DRV_SEL_VOD = 3). Measured with minimal input channel and minimum EQ using a 1 GHz signal.		850		mVpp
		Measured with a mid wide-band gain setting (EQ_HIGH_GAIN = 1, DRV_SEL_VOD = 0). Measured with minimal input channel and minimum EQ using a 1 GHz signal.		900		mVpp
		Measured with a mid wide-band gain setting (EQ_HIGH_GAIN = 0, DRV_SEL_VOD = 3). Measured with minimal input channel and minimum EQ using a 1 GHz signal.		1050		mVpp
		Measured with the lowest wide-band gain setting (EQ_HIGH_GAIN = 0, DRV_SEL_VOD = 0). Measured with minimal input channel and minimum EQ using a 1 GHz signal.		1250		mVpp
HIGH-SPEED DIFFERENTIAL OUTPUTS (TXnP, TXnN)						
VOD _{idle}	Differential output amplitude, TX disabled or otherwise muted			< 10		mVpp
G _{DC}	Vout/Vin wide-band amplitude gain	Measured with the highest wide-band gain setting (EQ_HIGH_GAIN = 1, DRV_SEL_VOD = 3) at 20 MHz.		4.5		dB
		Measured with the lowest wide-band gain setting (EQ_HIGH_GAIN = 0, DRV_SEL_VOD = 0) at 20 MHz.		-5		dB
V _{cm-TX-AC}	Common-mode AC output noise	Defined as (TXP + TXN)/2. Measured with a low-pass filter with 3 dB bandwidth at 33 GHz.		6		mV, RMS
V _{cm-TX-DC}	Common-mode DC output	Defined as (TXP + TXN)/2. Measured with a DC signal.	0.75	0.96	1.05	V
RJ _{ADD-RMS}	Additive Random Jitter	Measured as a single-ended signal on a Keysight E5505A phase noise measurement solution with a 28 Gbps 1010 pattern. Additive RJ measured over a frequency range of 2 kHz to 20 MHz.		11		fs RMS

Over operating free-air temperature range (unless otherwise noted).

PARAMETER		TEST CONDITIONS	MIN	TYP	MAX	UNIT
RL _{SDD22}	Output differential-to-differential return loss	50 MHz to 4.8 GHz		< -16		dB
		4.8 GHz to 10 GHz		< -15		dB
		10 GHz to 14.1 GHz		< -8		dB
		14.1 GHz to 20 GHz		< -8		dB
RL _{SCD22}	Output common-mode-to-differential return loss	50 MHz to 6.0 GHz		< -21		dB
		6.0 GHz to 12.9 GHz		< -22		dB
		12.9 GHz to 14.1 GHz		< -21		dB
		14.1 GHz to 20 GHz		< -20		dB
RL _{SCC22}	Output Common-mode return loss	50 MHz to 3.3 GHz		< -13		dB
		3.3 GHz to 10.3 GHz		< -11		dB
		10.3 GHz to 20 GHz		< -9		dB

Over operating free-air temperature range (unless otherwise noted).

PARAMETER	TEST CONDITIONS	MIN	TYP	MAX	UNIT
OTHER PARAMETERS					
t_D	Input-to-output latency (propagation delay) through a channel	Straight-thru mode (no cross-point)		100	ps
t_D	Input-to-output latency (propagation delay) through a channel	Cross-over and mux mode (cross-point enabled)		100	ps
t_{SK}	Channel-to-channel interpair skew	Latency difference between channels		<14	ps
T_{EEPROM}	EEPROM configuration load time	Time to assert ALL_DONE_N after REAN_EN_N has been asserted. Single device reading its configuration from an EEPROM with common channel configuration. This time scales with the number of devices reading from the same EEPROM. Does not include power-on reset time.		4	ms
		Time to assert ALL_DONE_N after REAN_EN_N has been asserted. Single device reading its configuration from an EEPROM. Non-common channel configuration. This time scales with the number of devices reading from the same EEPROM. Does not include power-on reset time.		7	ms
T_{POR}	Power-on reset assertion time	Internal power-on reset (PoR) stretch between stable power supply and de-assertion of internal PoR. The SMBus address is latched on the completion of the PoR stretch, and SMBus accesses are permitted once PoR completes.		60	ms

- (1) Max values assume VDD = 2.5 V + 5%.
- (2) This pin has an internal weak pull-up.
- (3) This pin has an internal weak pull-down.

表 7-1. Electrical Characteristics - Serial Management Bus Interface

PARAMETER	TEST CONDITIONS	MIN	TYP	MAX	UNIT
V_{IH}	Input high level voltage	SDA and SDC	1.75	3.6	V
V_{IL}	Input low level voltage	SDA and SDC	GND	0.8	V
V_{OL}	Output low level voltage	SDA and SDC, $I_{OL} = 1.25$ mA	GND	0.4	V
C_{IN}	Input pin capacitance	SDA and SDC	15		pF
I_{IN}	Input current	SDA or SDC, $V_{INPUT} = V_{IN}, V_{DD}, GND$	-18	18	μ A

7.6 Timing Requirements - Serial Management Bus Interface

Over operating free-air temperature range (unless otherwise noted).

PARAMETER	TEST CONDITIONS	MIN	TYP	MAX	UNIT	
RECOMMENDED SMBus SWITCHING CHARACTERISTICS (SMBus SLAVE MODE)						
f_{SDC}	SDC clock frequency	EN_SMB = 1k to VDD (Slave Mode)	10	100	400	kHz
T_{SDA-HD}	Data hold time		0.75			ns
T_{SDA-SU}	Data setup time		100			ns
T_{SDA-R}	SDA rise time, read operation	Pull-up resistor = 1 k Ω , Cb = 50 pF	150			ns
T_{SDA-F}	SDA fall time, read operation	Pull-up resistor = 1 k Ω , Cb = 50 pF	4.5			ns
SMBus SWITCHING CHARACTERISTICS (SMBus MASTER MODE)						
f_{SDC}	SDC clock frequency	EN_SMB = Float (Master Mode)	260	303	346	kHz

Over operating free-air temperature range (unless otherwise noted).

PARAMETER		TEST CONDITIONS	MIN	TYP	MAX	UNIT
$T_{SDC-LOW}$	SDC low period		1.66	1.90	2.21	μs
$T_{SDC-HIGH}$	SDC high period		1.22	1.40	1.63	μs
$T_{HD-START}$	Hold time start operation			0.6		μs
$T_{SU-START}$	Setup time start operation			0.6		μs
T_{SDA-HD}	Data hold time			0.9		μs
T_{SDA-SU}	Data setup time			0.1		μs
$T_{SU-STOP}$	Stop condition setup time			0.6		μs
T_{BUF}	Bus free time between Stop-Start			1.3		μs
T_{SDC-R}	SDC rise time	Pull-up resistor = 1 k Ω		300		ns
T_{SDC-F}	SDC fall time	Pull-up resistor = 1 k Ω		300		ns

7.7 Typical Characteristics

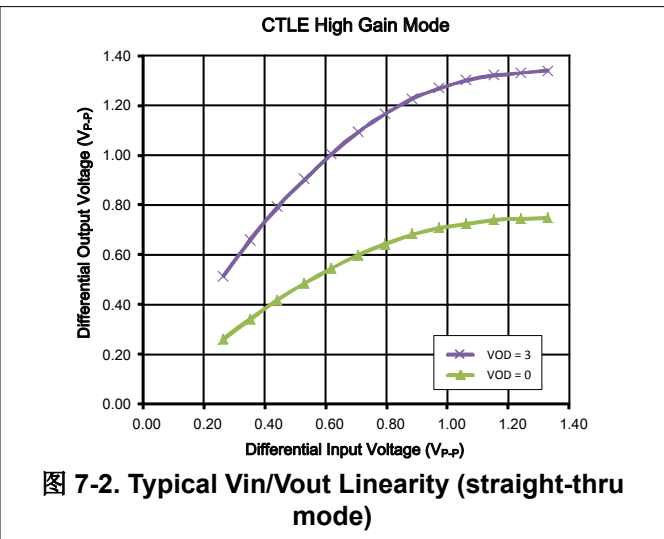
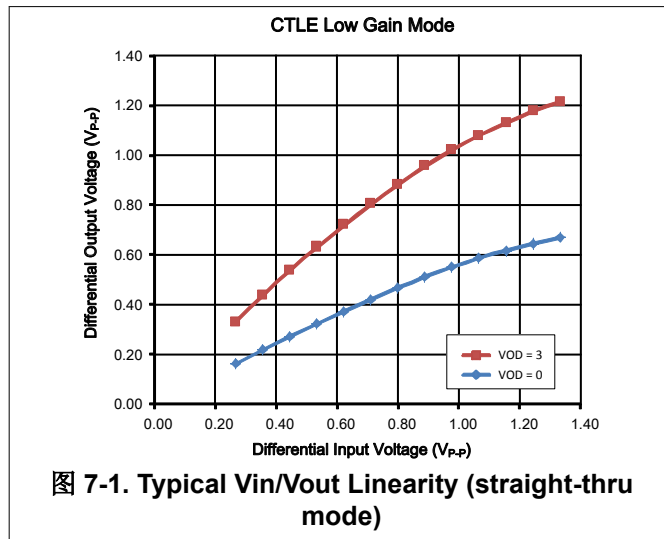

8 Detailed Description

8.1 Overview

The DS280MB810 is an eight-channel multi-rate linear repeater with integrated signal conditioning and cross-point. The eight channels operate independently from one another. Each channel includes a continuous-time linear equalizer (CTLE), multiplexer, and a linear output driver, which compensate for the presence of a dispersive transmission channel between the source transmitter and the final receiver.

Between each group of two adjacent channels (i.e. between channels 0 - 1, 2 - 3, 4 - 5, and 6 - 7) is a full 2x2 cross-point switch. This allows multiplexing and de-multiplexing or fanout applications for failover redundancy, as well as cross-over applications to aid PCB routing.

All receive channels on the DS280MB810 are AC-coupled with physical AC coupling capacitors (220 nF \pm 20%) on the package substrate. This ensures input common mode voltage compatibility with all link partner transmitters and eliminates the need for AC coupling capacitors on the system PCB, thereby saving cost and greatly reducing PCB routing complexity.

The DS280MB810 is configurable through a single SMBus port. The DS280MB810 can also act as an SMBus master to configure itself from an EEPROM.

The sections which follow describe the functionality of various circuits and features within the DS280MB810. For more information about how to program or operate these features refer to the DS280MB810 Programming Guide.

8.2 Functional Block Diagram

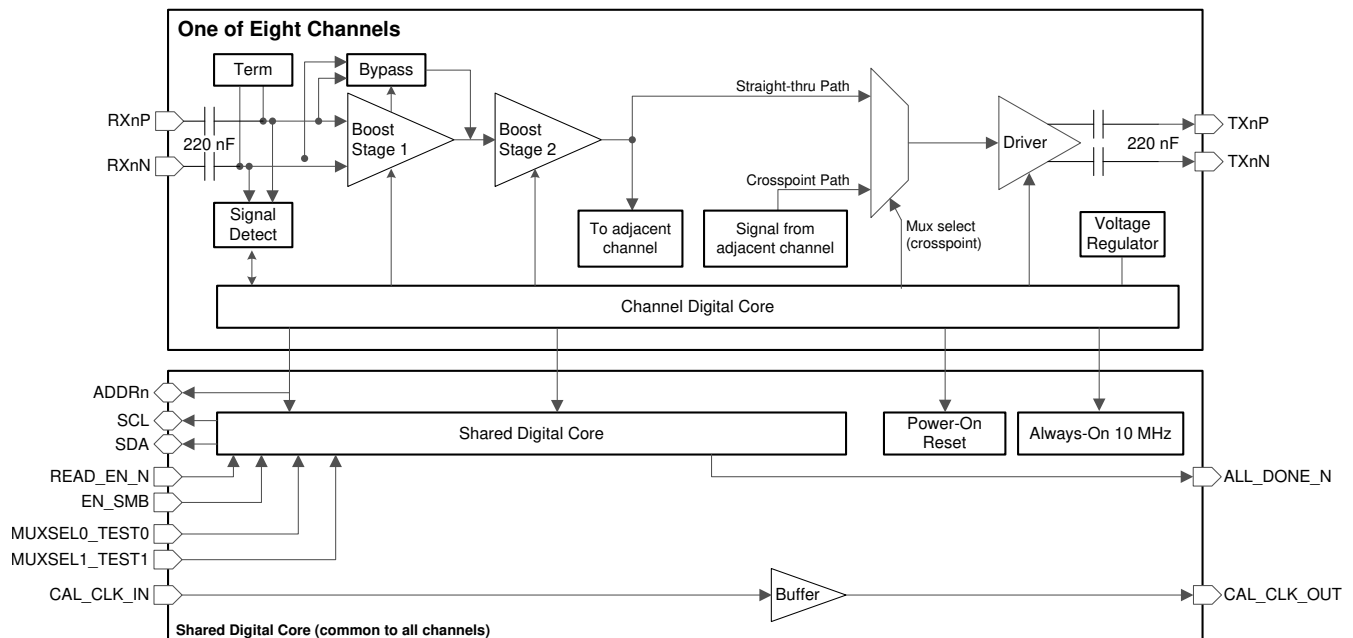

8.3 Feature Description

8.3.1 Device Data Path Operation

The DS280MB810 data path consists of several key blocks as shown in [节 8.2](#). These key circuits are:

- [节 8.3.2](#)
- [节 8.3.3](#)
- [节 8.3.4](#)
- [节 8.3.5](#)
- [节 8.3.6](#)
- [节 8.3.7](#)

8.3.2 AC-coupled Receiver Inputs

The differential receiver for each DS280MB810 channel contains an integrated on-die 100 Ω differential termination as well as 220 nF $\pm 20\%$ series AC coupling capacitors embedded onto the package substrate.

8.3.3 Signal Detect

Each DS280MB810 high speed receiver has a signal detect circuit which monitors the energy level on the inputs. The signal detect circuit will enable the high-speed data path if a signal is detected, or power it off if no signal is detected. By default, this feature is enabled, but can be manually controlled through the SMBus channel registers. This can be useful if it is desired to manually force channels to be disabled. For information on how to manually operate the signal detect circuit refer to the DS280MB810 Programming Guide.

8.3.4 2-Stage CTLE

The continuous-time linear equalizer (CTLE) in the DS280MB810 consists of two stages which are configurable through the SMBus channel registers. This CTLE is designed to be highly linear to allow the DS280MB810 to preserve the transmitter's pre-cursor and post cursor signal characteristics. This highly linear behavior enables the DS280MB810 to be used in applications that use protocols such as link training, where it is important to recover and pass through incremental changes in transmit equalization.

Each stage in the CTLE has 3-bit boost control. The first CTLE stage provides a coarse adjustment of the total boost. Larger settings correspond to higher total boost. The first stage can be bypassed entirely to achieve the lowest possible total boost. The second CTLE stage acts as a fine adjustment on the total boost and impacts the shape of the boost curve accordingly. Larger settings correspond to higher total boost. The bandwidth of the CTLE can be adjusted using a 2-bit bandwidth control. Larger settings correspond to higher total bandwidth. For information on how to program the CTLE refer to the DS280MB810 Programming Guide.

In addition to high-frequency boost, the CTLE can apply wide-band amplitude gain. There are two settings (high-gain and low-gain) which work together with the driver DC gain control to affect the total input-to-output wide-band amplitude gain.

8.3.5 Driver DC Gain Control

In addition to the high-frequency boost provided by the CTLE, the DS280MB810 is also able to provide additional DC or low-frequency gain. The effective DC gain is controlled by a 3-bit field, allowing for eight levels of DC attenuation or DC gain. For information on how to configure the DC gain refer to the DS280MB810 Programming Guide.

8.3.6 2x2 Cross-point Switch

Between each group of two adjacent channels (i.e. between channels 0 – 1, 2 – 3, 4 – 5, and 6 – 7) is a full 2x2 cross-point switch. The cross-point can be configured through pin-mode (shared register 0x05[1]=1) or SMBus registers (shared register 0x05[1]=0) to operate as follows:

- Straight-thru mode
- Multiplex two inputs to one output
- Fanout one input to two outputs

- Cross two inputs to two outputs

图 8-1 shows the four 2x2 cross-points available in the DS280MB810, and 图 8-2 shows how each cross-point can be configured for straight-thru, multiplex, de-multiplex, or cross-over applications. Refer to the DS280MB810 Programming Guide for details on how to program the cross-point through SMBus registers.



图 8-1. Block diagram showing all four 2x2 cross-points in the DS280MB810



图 8-2. Signal distribution options available in each 2x2 cross-point (channel A can be 0, 2, 4, or 6; channel B can be 1, 3, 5, or 7)

The switching operation of the cross-point can be configured with the MUXSEL0 and MUXSEL1 pins when shared register 0x05[1]=1. Note that shared register 0x05[1] of both quads must be set to 1 to enable pin-control

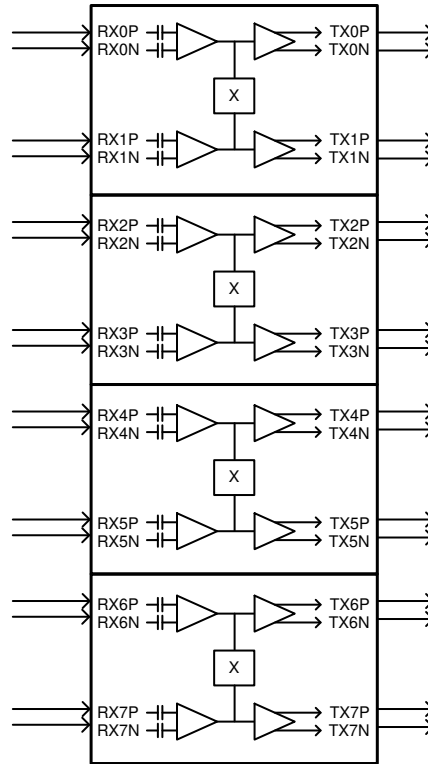
cross-point mode. Each quad can be selected through Reg_0xFF[5:4]. Refer to the DS280MB810 Programming Guide for more information.

The behavior of the cross-point (i.e. straight-thru, fanout, or mux) for each state of MUXSEL is illustrated in [Figure 8-3](#). Note that MUXSEL0 controls channels 0, 1, 4, and 5; and MUXSEL1 controls channels 2, 3, 6, and 7.

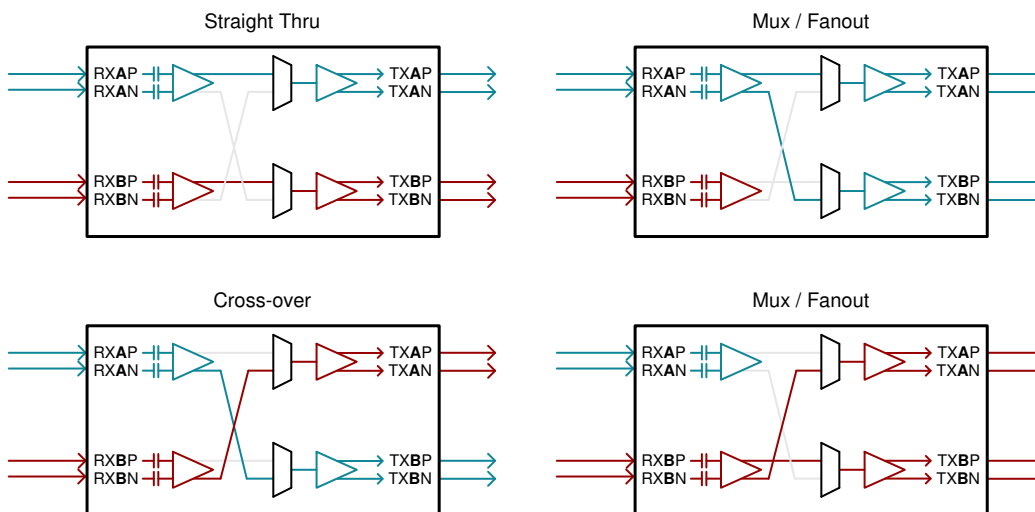
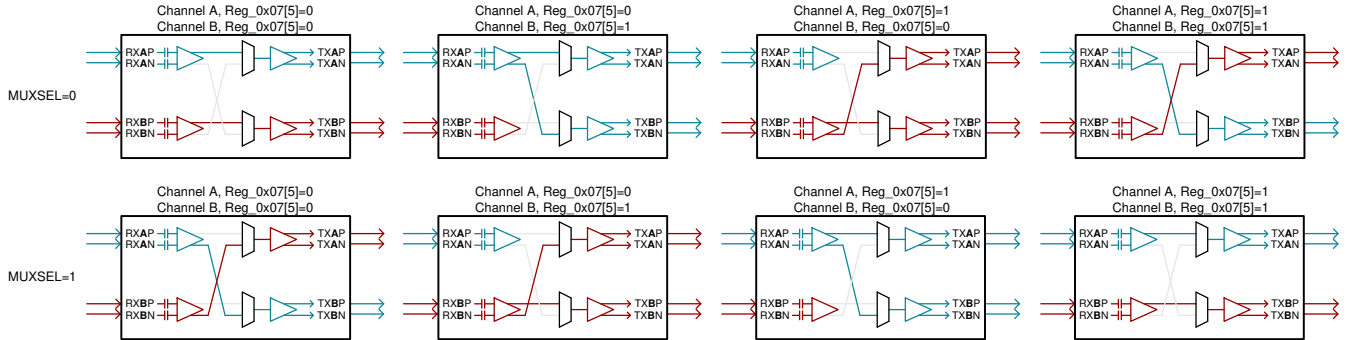

Figure 8-3. Signal distribution configuration options when using pin-control mode (channel A can be 0, 2, 4, or 6; channel B can be 1, 3, 5, or 7)

8.3.7 Configurable SMBus Address

The DS280MB810's SMBus slave address is strapped at power up using the ADDR[1:0] pins. The pin state is read on power up, after the internal power-on reset completes. The ADDR[1:0] pins are four-level LVCMOS I/Os, which provide for 16 unique SMBus addresses. [Table 8-1](#) lists the DS280MB810 SMBus slave address options.

Table 8-1. SMBus Address Map

7-BIT SLAVE ADDRESS	8-BIT WRITE ADDRESS	REQUIRED ADDRESS PIN STRAP VALUE	
		ADDR1	ADDR0
0x18	0x30	0	0
0x19	0x32	0	R
0x1A	0x34	0	F
0x1B	0x36	0	1
0x1C	0x38	R	0
0x1D	0x3A	R	R
0x1E	0x3C	R	F
0x1F	0x3E	R	1
0x20	0x40	F	0
0x21	0x42	F	R
0x22	0x44	F	F
0x23	0x46	F	1
0x24	0x48	1	0
0x25	0x4A	1	R
0x26	0x4C	1	F
0x27	0x4E	1	1

8.4 Device Functional Modes

8.4.1 SMBus Slave Mode Configuration

To configure the DS280MB810 for SMBus slave mode connect the EN_SMB pin to VDD with a 1-kΩ resistor. When the DS280MB810 is configured for SMBus slave mode operation the READ_EN_N becomes an active-low reset pin, resetting register values when driven to LOW, or V_{IL}. Additionally, when the DS280MB810 is configured for SMBus slave mode the ALL_DONE_N output pin is high-Z; except for when READ_EN_N is

driven LOW which causes ALL_DONE_N to also be driven LOW. Refer to 节 8.6 for additional register information.

8.4.2 SMBus Master Mode Configuration (EEPROM Self Load)

To configure the DS280MB810 for SMBus master mode, leave the EN_SMB pin floating (no connect). If the DS280MB810 is configured for SMBus master mode, it will remain in the SMBus IDLE state until the READ_EN_N pin is asserted to LOW, or V_{IL} . Once the READ_EN_N pin is driven LOW, the DS280MB810 becomes an SMBus master and attempts to self-configure by reading device settings stored in an external EEPROM (SMBus 8-bit address 0xA0). When the DS280MB810 has finished reading from the EEPROM successfully, it will drive the ALL_DONE_N pin LOW and then change from an SMBus master to an SMBus slave. Not all bits in the register map can be configured through an EEPROM load. Refer to the DS280MB810 Programming Guide for more information.

When designing a system for using the external EEPROM, the user must follow these guidelines:

- Maximum EEPROM size is 8 kb (1024 x 8-bit).
- Set EN_SMB = FLOAT to configure for SMBus master mode.
- The external EEPROM 8-bit device address must be 0xA0 and capable of 400 kHz operation at 2.5 V or 3.3 V supply.
- Once the DS280MB810 completes its EEPROM load the device becomes an SMBus slave on the control bus.
- If multiple DS280MB810 devices share a single EEPROM, connect the ALL_DONE_N output of the first device to the READ_EN_N input of the next device, as shown in 图 8-4.



图 8-4. Example daisy chain for multiple device, single EEPROM configuration

When tying multiple DS280MB810 devices to the SDA and SDC bus, use these guidelines to configure the devices for SMBus master mode:

- Use SMBus ADDR[1:0] address bits so that each device can load its configuration from the EEPROM. The example below is for four devices. The first device in the sequence conventionally uses the 8-bit slave write address 0x30, while subsequent devices follow the address order listed below.
 - DS280MB810 instance 1 (U1): ADDR[1:0] = {0, 0} = 0x30
 - DS280MB810 instance 2 (U2): ADDR[1:0] = {0, R} = 0x32
 - DS280MB810 instance 3 (U3): ADDR[1:0] = {0, F} = 0x34
 - DS280MB810 instance 4 (U4): ADDR[1:0] = {0, 1} = 0x36
- Use a pull-up resistor on SDA and SDC; resistor value = 2 k Ω to 5 k Ω is adequate.
- Float (no connect) the EN_SMB pin (E3) on all DS280MB810 devices to configure them for SMBus master mode. The EN_SMB pin should not be dynamically changed between the high and float states.
- Daisy-chain READ_EN_N (pin F13) and ALL_DONE_N (pin D3) from one device to the next device in the following sequence so that they do not compete for master control of the EEPROM at the same time.
 1. Tie READ_EN_N of the first device in the chain (U1) to GND to trigger EEPROM read immediately after the DS280MB810 power-on reset (PoR) completes. Alternatively, drive the READ_EN_N pin from a control device (micro-controller or FPGA) to trigger the EEPROM read at a specific time.
 2. Tie ALL_DONE_N of U1 to READ_EN_N of U2
 3. Tie ALL_DONE_N of U2 to READ_EN_N of U3
 4. Tie ALL_DONE_N of U3 to READ_EN_N of U4
 5. Optional: Tie ALL_DONE_N output of U4 to a micro-controller or an LED to show the devices have been loaded successfully.

Once the ALL_DONE_N status pin of the last device is flagged to indicate that all devices sharing the SMBus line have been successfully programmed, control of the SMBus line is released by the DS280MB810. The device then reverts back to SMBus slave mode. At this point, an external controller can perform any additional Read or Write operations to the DS280MB810.

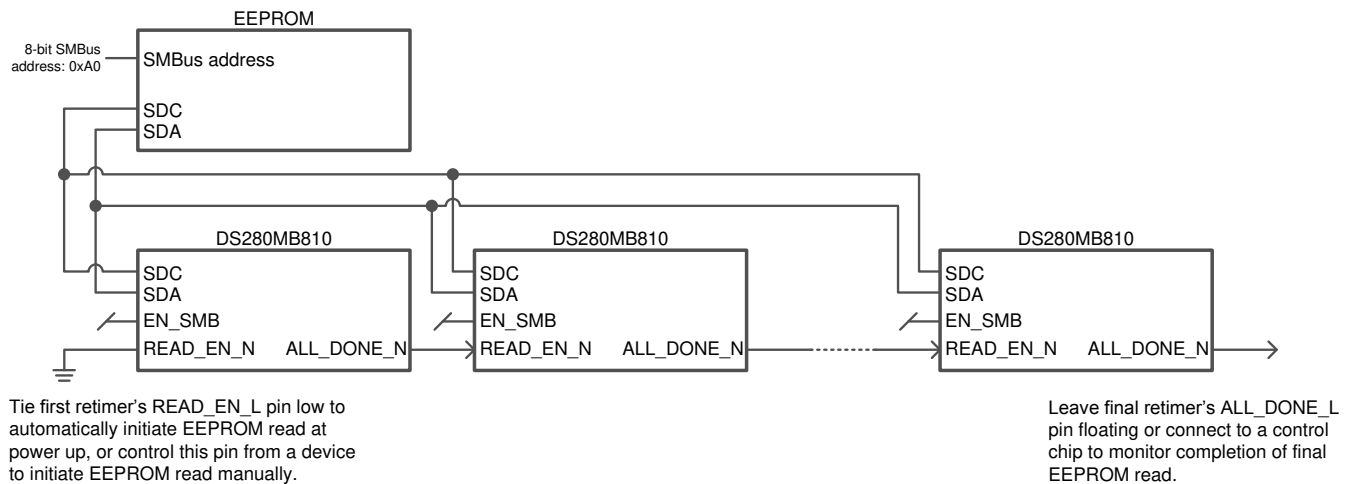
Refer to the DS280MB810 Programming Guide for additional information concerning SMBus master mode.

8.5 Programming

The DS280MB810 can be programmed in two ways. The DS280MB810 can be configured as an SMBus slave (EN_SMB = HIGH) or the device can temporarily act as an SMBus master and load its configuration settings from an external EEPROM (EN_SMB = FLOAT). Refer to [§ 8.4.1](#) and [§ 8.4.2](#) for details.

8.5.1 Transfer of Data with the SMBus Interface

The System Management Bus (SMBus) is a two-wire serial interface through which a master can communicate with various system components. Slave devices are identified by a unique device address. The two-wire serial interface consists of SDC and SDA signals. SDC is a clock output from the master to all of the slave devices on the bus. SDA is a bidirectional data signal between the master and slave devices. The DS280MB810 SMBus SDC and SDA signals are open drain and require external pull-up resistors.

Start and Stop Conditions:

The master generates Start and Stop conditions at the beginning and end of each transaction:

- Start: High to LOW transition (falling edge) of SDA while SDC is HIGH.
- Stop: Low to HIGH transition (rising edge) of SDA while SDC is HIGH.

The master generates 9 clock pulses for each byte transfer. The 9th clock pulse constitutes the acknowledge (ACK) cycle. The transmitter releases SDA to allow the receiver to send the ACK signal. An ACK is when the device pulls SDA LOW, while a NACK (no acknowledge) is recorded if the line remains HIGH.

Writing data from a master to a slave consists of three parts:

- The master begins with a start condition followed by the slave device address with the R/W bit cleared.
- The master sends the 8-bit register address that will be written.

- The master sends the data byte to write for the selected register address. The register address pointer will then increment, so the master can send the data byte for the subsequent register without re-addressing the device, if desired. The final data byte to write should be followed by a stop condition.

SMBus read operations consist of four parts:

- The master initiates the read cycle with start condition followed by slave device address with the R/W bit cleared.
- The master sends the 8-bit register address that will be read.
- After acknowledgment from the slave, the master initiates a re-start condition.
- The slave device address is resent followed with R/W bit set.
- After acknowledgment from the slave, the data is read back from the slave to the master. The last ACK is HIGH if there are no more bytes to read.

8.6 Register Maps

Many of the registers in the DS280MB810 are divided into bit fields. This allows a single register to serve multiple purposes which may be unrelated. Often, configuring the DS280MB810 requires writing a bit field that makes up only part of a register value while leaving the remainder of the register value unchanged. The procedure for accomplishing this task is to read in the current value of the register to be written, modify only the desired bits in this value, and write the modified value back to the register. This sequence is commonly referred to as Read-Modify-Write. If the entire register is to be changed, rather than just a bit field within the register, it is not necessary to read in the current value of the register first.

Most register bits can be read or written to. However, some register bits are constrained to specific interface instructions.

Register bits can have the following interface constraints:

- R - Read only
- RW - Read/Write
- RWSC - Read/Write, Self-Clearing

8.6.1 Register Types: Global, Shared, and Channel

The DS280MB810 has 3 types of registers:

1. Global Registers - These registers can be accessed at any time and are used to select between individual channel registers and shared registers, or to read back the TI ID and version information.
2. Shared Registers - These registers are used for device-level configuration, status read back or control. Set register 0xFF[0] = 0 and configure 0xFF[5:4] to access the shared registers.
3. Channel Registers - These registers are used to control and configure specific features for each individual channel. All channels have the same channel register set and can be configured independent of each other. Set register 0xFF[0] = 1 and configure register 0xFC to access the desired channel register set.

Refer to the Programming Guide for additional information on register configuration.

8.6.2 Global Registers: Channel Selection and ID Information

The global registers can be accessed at any time, regardless of whether the shared or channel register set is selected. The DS280MB810 global registers are located at address 0xEF - 0xFF.

表 8-2. Global Register Map

Addr [HEX]	Bit	Default [HEX]	Mode	EEPROM	Field	Description
0xEF		0x0C			General	
	7	0	RW	N	RESERVED	RESERVED
	6	0	RW	N	RESERVED	RESERVED
	5	0	RW	N	RESERVED	RESERVED
	4	0	RW	N	RESERVED	RESERVED
	3	1	R	N	DEVICE_ID_QUAD_CNT[3]	TI device ID (quad count). Contains 0x0C.
	2	1	R	N	DEVICE_ID_QUAD_CNT[2]	
	1	0	R	N	DEVICE_ID_QUAD_CNT[1]	
	0	0	R	N	DEVICE_ID_QUAD_CNT[0]	
0xF0		0x00			Version Revision	
	7	0	R	N	TYPE	TI version ID. Contains 0x00.
	6	0	R	N	VERSION[6]	
	5	0	R	N	VERSION[5]	
	4	0	R	N	VERSION[4]	
	3	0	R	N	VERSION[3]	
	2	0	R	N	VERSION[2]	
	1	0	R	N	VERSION[1]	
	0	0	R	N	VERSION[0]	
0xF1		0x42			Channel Control	
	7	0	R	N	DEVICE_ID[7]	TI device ID. Contains 0x42.
	6	1	R	N	DEVICE_ID[6]	
	5	0	R	N	DEVICE_ID[5]	
	4	0	R	N	DEVICE_ID[4]	
	3	0	R	N	DEVICE_ID[3]	
	2	0	R	N	DEVICE_ID[2]	
	1	1	R	N	DEVICE_ID[1]	
	0	0	R	N	DEVICE_ID[0]	
0xF3		0x00			Channel Control	
	7	0	R	N	CHAN_VERSION[3]	TI digital channel version ID. Contains 0x00.
	6	0	R	N	CHAN_VERSION[2]	
	5	0	R	N	CHAN_VERSION[1]	
	4	0	R	N	CHAN_VERSION[0]	
	3	0	R	N	SHARE_VERSION[3]	TI digital share version ID. Contains 0x00.
	2	0	R	N	SHARE_VERSION[2]	
	1	0	R	N	SHARE_VERSION[1]	
	0	0	R	N	SHARE_VERSION[0]	

表 8-2. Global Register Map (continued)

Addr [HEX]	Bit	Default [HEX]	Mode	EEPROM	Field	Description
0xFC		0x00			General	
	7	0	RW	N	EN_CH7	Select channel 7
	6	0	RW	N	EN_CH6	Select channel 6
	5	0	RW	N	EN_CH5	Select channel 5
	4	0	RW	N	EN_CH4	Select channel 4
	3	0	RW	N	EN_CH3	Select channel 3
	2	0	RW	N	EN_CH2	Select channel 2
	1	0	RW	N	EN_CH1	Select channel 1
	0	0	RW	N	EN_CH0	Select channel 0
0xFD		0x00				
	7	0	RW	N	RESERVED	RESERVED
	6	0	RW	N	RESERVED	RESERVED
	5	0	RW	N	RESERVED	RESERVED
	4	0	RW	N	RESERVED	RESERVED
	3	0	RW	N	RESERVED	RESERVED
	2	0	RW	N	RESERVED	RESERVED
	1	0	RW	N	RESERVED	RESERVED
	0	0	RW	N	RESERVED	RESERVED
0xFE		0x03			Vendor ID	
	7	0	R	N	VENDOR_ID[7]	TI vendor ID. Contains 0x03.
	6	0	R	N	VENDOR_ID[6]	
	5	0	R	N	VENDOR_ID[5]	
	4	0	R	N	VENDOR_ID[4]	
	3	0	R	N	VENDOR_ID[3]	
	2	0	R	N	VENDOR_ID[2]	
	1	1	R	N	VENDOR_ID[1]	
	0	1	R	N	VENDOR_ID[0]	
0xFF		0x10			Channel Control	
	7	0	RW	N	RESERVED	RESERVED
	6	0	RW	N	RESERVED	RESERVED
	5	0	RW	N	EN_SHARE_Q1	Select shared registers for Quad 1 (Channels 4-7).
	4	1	RW	N	EN_SHARE_Q0	Select shared registers for Quad 0 (Channels 0-3).
	3	0	RW	N	RESERVED	RESERVED
	2	0	RW	N	RESERVED	RESERVED
	1	0	RW	N	WRITE_ALL_CH	Allows customer to write to all channels as if they are the same, but only allows to read back from the channel specified in 0xFC and 0xFD. Note: EN_CH_SMB must be = 1 or else this function is invalid.
	0	0	RW	N	EN_CH_SMB	1: Enables SMBus access to the channels specified in register 0xFC. 0: The shared registers are selected, see 0xFF[5:4].

8.6.3 Shared Registers

表 8-3. Shared Register Map

Addr [HEX]	Bit	Default [HEX]	Mode	EEPROM	Field	Description
0x00		0x01			General	
	7	0	R	N	I ² C_ADDR[3]	I ² C strap observation. The device 7-bit slave address is 0x18 + I ² C_ADDR[3:0].
	6	0	R	N	I ² C_ADDR[2]	
	5	0	R	N	I ² C_ADDR[1]	
	4	0	R	N	I ² C_ADDR[0]	
	3	0	R	N	RESERVED	RESERVED
	2	0	R	N	RESERVED	RESERVED
	1	0	R	N	RESERVED	1'b when Quad1 Shared registers enabled.
	0	1	R	N	RESERVED	1'b when Quad0 Shared registers enabled.
0x01		0x02			Version Revision	
	7	0	R	N	RESERVED	RESERVED
	6	0	R	N	RESERVED	RESERVED
	5	0	R	N	RESERVED	RESERVED
	4	0	R	N	RESERVED	RESERVED
	3	0	R	N	RESERVED	RESERVED
	2	0	R	N	RESERVED	RESERVED
	1	1	R	N	RESERVED	RESERVED
	0	0	R	N	RESERVED	RESERVED
0x02		0x00			Channel Control	
	7	0	RW	N	RESERVED	RESERVED
	6	0	RW	N	RESERVED	RESERVED
	5	0	RW	N	RESERVED	RESERVED
	4	0	RW	N	RESERVED	RESERVED
	3	0	RW	N	RESERVED	RESERVED
	2	0	RW	N	RESERVED	RESERVED
	1	0	RW	N	RESERVED	RESERVED
	0	0	RW	N	RESERVED	RESERVED
0x03		0x00			Channel Control	
	7	0	RW	N	RESERVED	RESERVED
	6	0	RW	N	RESERVED	RESERVED
	5	0	RW	N	RESERVED	RESERVED
	4	0	RW	N	RESERVED	RESERVED
	3	0	RW	N	RESERVED	RESERVED
	2	0	RW	N	RESERVED	RESERVED
	1	0	RW	N	RESERVED	RESERVED
	0	0	RW	N	RESERVED	RESERVED
0x04		0x01			General	
	7	0	RW	N	RESERVED	RESERVED
	6	0	RWSC	N	RST_I ² C_REGS	1: Reset shared registers, bit is self-clearing. 0: Normal operation
	5	0	RWSC	N	RST_I ² C_MAS	1: Self-clearing reset for I ² C master. 0: Normal operation
	4	0	RW	N	FRC_EEPRM_RD	1: Override EN_SMB and input chain status to force EEPROM Configuration. 0: Normal operation
	3	0	RW	N	RESERVED	RESERVED
	2	0	RW	N	REGS_CLOCK_EN	RESERVED

表 8-3. Shared Register Map (continued)

Addr [HEX]	Bit	Default [HEX]	Mode	EEPROM	Field	Description
	1	0	RW	N	I ² C_MAS_CLK_EN	RESERVED
	0	1	RW	N	I ² CSLV_CLK_EN	RESERVED
0x05		0x00			General	
	7	0	RW	N	DISAB_EEPRM_CFG	1: Disable Master Mode EEPROM Configuration (If not started, not effective midway or after configuration). 0: Normal operation
	6	0	RW	N	CRC_EN	RESERVED
	5	0	RW	N	ML_TEST_CONTROL	RESERVED
	4	0	R	N	EEPROM_READING_DONE	Sets 1 when EEPROM reading is done.
	3	0	R	N	RESERVED	RESERVED
	2	0	R	Y	CAL_CLK_INV_DIS	1: Disable the inversion of CAL_CLK_OUT. 0: Normal operation, CAL_CLK_OUT is inverted with respect to CAL_CLK_IN.
	1	0	R	N	MUX_CONFIG_PIN_CTRL	1: MUXSEL0_TEST0 and MUXSEL1_TEST1 are used to configure the cross-point mux. MUXSEL0_TEST0 controls the cross-point for channels 0 - 1 and 4 - 5. MUXSEL1_TEST1 controls the cross-point for channels 2 - 3 and 6 - 7. For mux pin-control, Reg_05[0] must also be 0, which is the power-on default value. 0: Cross-point mux is configured on a per-channel basis with Reg_0x06[0].
	0	0	R	N	TEST0_AS_CAL_CLK	RESERVED
0x06		0x00			General	
	7	0	RW	N	RESERVED	RESERVED
	6	0	RW	N	RESERVED	RESERVED
	5	0	RW	N	RESERVED	RESERVED
	4	0	RW	N	RESERVED	RESERVED
	3	0	RW	N	RESERVED	RESERVED
	2	0	RW	N	RESERVED	RESERVED
	1	0	RW	N	RESERVED	RESERVED
	0	0	RW	N	RESERVED	RESERVED
0x07		0x00			General	
	7	0	RW	N	RESERVED	RESERVED
	6	0	R	N	CAL_CLK_DET	1: Indicates that CAL_CLK has been detected. 0: Indicates that CAL_CLK has not been detected.
	5	0	RW	N	RESERVED	RESERVED
	4	0	RW	N	RESERVED	RESERVED
	3	0	RW	N	MR_CAL_CLK_DET_DIS	1: Disable CAL_CLK detect. 0: Enable CAL_CLK detect.
	2	0	RW	N	RESERVED	RESERVED
	1	0	RW	N	RESERVED	RESERVED
	0	0	RW	Y	DIS_CAL_CLK_OUT	1: Disable CAL_CLK_OUT, output is high-Z. 0: Enable CAL_CLK_OUT.
0x08		0x00			General	
	7	0	RW	N	RESERVED	RESERVED
	6	0	RW	N	RESERVED	RESERVED
	5	0	RW	N	RESERVED	RESERVED
	4	0	RW	N	RESERVED	RESERVED
	3	0	RW	N	RESERVED	RESERVED
	2	0	RW	N	RESERVED	RESERVED
	1	0	RW	N	RESERVED	RESERVED

表 8-3. Shared Register Map (continued)

Addr [HEX]	Bit	Default [HEX]	Mode	EEPROM	Field	Description
	0	0	RW	N	RESERVED	RESERVED
0x09		0x00			General	
	7	0	R	N	RESERVED	RESERVED
	6	0	R	N	RESERVED	RESERVED
	5	0	R	N	RESERVED	RESERVED
	4	0	R	N	RESERVED	RESERVED
	3	0	R	N	RESERVED	RESERVED
	2	0	R	N	RESERVED	RESERVED
	1	0	R	N	RESERVED	RESERVED
	0	0	R	N	RESERVED	RESERVED
0x0A		0x00			General	
	7	0	RW	N	RESERVED	RESERVED
	6	0	RW	N	RESERVED	RESERVED
	5	0	RW	N	RESERVED	RESERVED
	4	0	RW	N	RESERVED	RESERVED
	3	0	RW	N	RESERVED	RESERVED
	2	0	RW	N	RESERVED	RESERVED
	1	0	R	N	RESERVED	RESERVED
	0	0	R	N	RESERVED	RESERVED
0x0B		0x00				
	7	0	R	N	EECFG_CMPLT	11: Not valid. 10: EEPROM load completed successfully.
	6	0	R	N	EECFG_FAIL	01: EEPROM load failed after 64 attempts. 00: EEPROM load in progress.
	5	0	R	N	EECFG_ATMPT[5]	Indicates number of attempts made to load EEPROM image.
	4	0	R	N	EECFG_ATMPT[4]	
	3	0	R	N	EECFG_ATMPT[3]	
	2	0	R	N	EECFG_ATMPT[2]	
	1	0	R	N	EECFG_ATMPT[1]	
	0	0	R	N	EECFG_ATMPT[0]	
0x0C		0x91				
	7	1	RW	N	I ² C_FAST	1: EEPROM load uses Fast I ² C Mode (400 kHz). 0: EEPROM load uses Standard I ² C Mode (100 kHz).
	6	0	RW	N	I ² C_SDA_HOLD[2]	Internal SDA Hold Time This field configures the amount of internal hold time provided for the SDA input relative to the SDC input. Units are 100 ns.
	5	0	RW	N	I ² C_SDA_HOLD[1]	
	4	1	RW	N	I ² C_SDA_HOLD[0]	
	3	0	RW	N	I ² C_FLTR_DEPTH[3]	I ² C Glitch Filter Depth This field configures the maximum width of glitch pulses on the SDC and SDA inputs that will be rejected. Units are 100 ns.
	2	0	RW	N	I ² C_FLTR_DEPTH[2]	
	1	0	RW	N	I ² C_FLTR_DEPTH[1]	
	0	1	RW	N	I ² C_FLTR_DEPTH[0]	

8.6.4 Channel Registers

表 8-4. Channel Register Map

Addr [HEX]	Bit	Default [HEX]	Mode	EEPROM	Field	Description
0x00		0x00			General	
	7	0	RW	N	CLK_CORE_DISAB	1: Disables 10 M core clock. This is the main clock domain for all the state machines. 0: Normal operation
	6	0	RW	N	CLK_REGS_EN	1: Force enable the clock to the registers. Normally, the register clock is enabled automatically on a needed basis. 0: Normal operation
	5	0	RW	N	RESERVED	RESERVED
	4	0	RW	N	CLK_REF_DISAB	1: Disables the 25 MHz CAL_CLK domain. 0: Normal operation
	3	0	RW	N	RST_CORE	1: Reset the 10 M core clock domain. This is the main clock domain for all the state machines. 0: Normal operation
	2	0	RWSC	N	RST_REGS	1: Reset channel registers to power-up defaults. 0: Normal operation
	1	0	RW	N	RESERVED	RESERVED
	0	0	RW	N	RST_CAL_CLK	1: Resets the 25 MHz reference clock domain. 0: Normal operation
0x01		0x01			SIG_DET	
	7	0	R	N	SIGDET	Signal detect status. 1: Signal detected at RX inputs. 0: No signal detected at RX inputs.
	6	0	R	N	SIGDET_ADJACENT	Signal detect status of adjacent channel. "Adjacent," referring to channel N+1 if N is even, or channel N-1 if N is odd. 1: Signal detected at RX inputs of adjacent channel. 0: No signal detected at RX inputs.
	5	0	R	N	RESERVED	RESERVED
	4	0	R	N	RESERVED	RESERVED
	3	0	R	N	RESERVED	RESERVED
	2	0	R	N	RESERVED	RESERVED
	1	0	R	N	RESERVED	RESERVED
	0	1	R	N	RESERVED	RESERVED
0x02		0x00				
	7	0	R	N	RESERVED	RESERVED
	6	0	R	N	RESERVED	RESERVED
	5	0	R	N	RESERVED	RESERVED
	4	0	R	N	RESERVED	RESERVED
	3	0	RW	N	RESERVED	RESERVED
	2	0	RW	N	RESERVED	RESERVED
	1	0	RW	N	RESERVED	RESERVED
	0	0	RW	N	RESERVED	RESERVED
0x03		0x80			CTLE_BOOST	
	7	1	RW	Y	EQ_BW[1]	EQ stage one buffer current (strength) control. Impacts EQ bandwidth. 2'b11 yields highest bandwidth, 2'b00 yields lowest bandwidth. Refer to the Programming Guide for more information.
	6	0	RW	Y	EQ_BW[0]	
	5	0	RW	Y	EQ_BST2[2]	EQ boost stage 2 controls. Directly goes to analog. No override bit is needed. Refer to the Programming Guide for more information.
	4	0	RW	Y	EQ_BST2[1]	
	3	0	RW	Y	EQ_BST2[0]	
	2	0	RW	Y	EQ_BST1[2]	EQ boost stage 1 controls. Directly goes to analog. No override bit is needed. Refer to the Programming Guide for more information.
	1	0	RW	Y	EQ_BST1[1]	
	0	0	RW	Y	EQ_BST1[0]	
0x04		0x90				

表 8-4. Channel Register Map (continued)

Addr [HEX]	Bit	Default [HEX]	Mode	EEPROM	Field	Description
	7	1	RW	N	RESERVED	RESERVED
	6	0	RW	N	EQ_PD_SD	1: Power down signal detect 0: Normal operation
	5	0	RW	Y	EQ_HIGH_GAIN	1: Enable EQ high gain 0: Enable EQ low gain
	4	1	RW	Y	EQ_EN_DC_OFF	RESERVED
	3	0	RW	Y	EQ_PD_EQ	1: Power down EQ 0: Enable EQ
	2	0	RW	N	RESERVED	RESERVED
	1	0	RW	Y	BG_SEL_IPP100[2]	CTLE bias programming. BG_SEL_IPP100[1:0] is in Reg_0x0F[5:4].
	0	0	RW	Y	EQ_EN_BYPASS	1: Enable EQ boost stage 1 (BST1) bypass. 0: Normal operation, signal travels through boost stage 1 (BST1).
0x05		0x04			SIG_DET_CONFIG	
	7	0	RW	Y	EQ_SD_PRESET	1: Force signal detect result to 1. 0: Normal operation This bit should not be set if 0x05[6] is also set.
	6	0	RW	Y	EQ_SD_RESET	1: Force signal detect result to 0. 0: Normal operation This bit should not be set if 0x05[7] is also set.
	5	0	RW	Y	EQ_REFA_SEL[1]	Signal detect assert thresholds. Refer to the Programming Guide for more information.
	4	0	RW	Y	EQ_REFA_SEL[0]	
	3	0	RW	Y	EQ_REFD_SEL[1]	Signal detect de-assert thresholds. Refer to the Programming Guide for more information.
	2	1	RW	Y	EQ_REFD_SEL[0]	
	1	0	RW	N	RESERVED	RESERVED
	0	0	RW	N	RESERVED	RESERVED
0x06		0xC0			GPIO2 Config	
	7	1	RW	Y	DRV_SEL_VOD[1]	Driver VOD adjust (DC gain). Refer to the Programming Guide for more information.
	6	1	RW	Y	DRV_SEL_VOD[0]	
	5	0	RW	Y	DRV_EQ_PD_OV	1: Driver and equalizer power down manually with Reg_0x06[3] and Reg_0x04[3], respectively. 0: Driver and equalizer are powered down or up by default when LOS=1/0.
	4	0	RW	Y	DRV_SEL_MUTE_OV	Driver mute override: 1: Use register 0x06[1] for mute control. 0: Normal operation. Mute is automatically controlled by signal detect.
	3	0	RW	Y	DRV_PD	1: Power down the driver. 0: Normal operation, driver power on or off is controlled by signal detect.
	2	0	RW	Y	DRV_PD_CM_LOOP	1: Disable the driver's common mode loop control circuit. 0: Normal operation, common mode loop enabled.
	1	0	RW	Y	DRV_SEL_MUTE	1: Mute driver if override bit is enabled. 0: Normal operation
	0	0	RW	Y	DRV_SEL_SOURCE	Select the signal source for the current channel's driver using the cross-point. 1: Transmit the signal from the adjacent channel. 0: Transmit the signal from the local channel.
0x07		0x00				
	7	0	RW	N	RESERVED	RESERVED
	6	0	RW	N	RESERVED	RESERVED

表 8-4. Channel Register Map (continued)

Addr [HEX]	Bit	Default [HEX]	Mode	EEPROM	Field	Description
	5	0	RW	Y	MUX_INV_PIN_CTRL	Invert the mux pin control. Only applicable if Shared Reg_0x05[1]=1. For channels 0, 1, 4, and 5 (controlled by MUXSEL0): 0: If MUXSEL0=0, channel is in straight-thru mode. If MUXSEL0=1, channel output is from adjacent channel's EQ. 1: If MUXSEL0=1, channel is in straight-thru mode. If MUXSEL0=0, channel output is from adjacent channel's EQ. For channels 2, 3, 6, and 7 (controlled by MUXSEL1): 0: If MUXSEL1=0, channel is in straight-thru mode. If MUXSEL1=1, channel output is from adjacent channel's EQ. 1: If MUXSEL1=1, channel is in straight-thru mode. If MUXSEL1=0, channel output is from adjacent channel's EQ.
	4	0	RW	N	RESERVED	RESERVED
	3	0	RW	N	RESERVED	RESERVED
	2	0	RW	N	RESERVED	RESERVED
	1	0	RW	N	RESERVED	RESERVED
	0	0	RW	N	RESERVED	RESERVED
0x08		0x50				
	7	0	RW	Y	RESERVED	RESERVED
	6	1	RW	Y	RESERVED	RESERVED
	5	0	RW	Y	RESERVED	RESERVED
	4	1	RW	Y	RESERVED	RESERVED
	3	0	RW	Y	BG_SEL_IPTAT25	1: Increases the current to the CTLE by 5%. 0: Default
	2	0	RW	N	RESERVED	RESERVED
	1	0	RW	N	RESERVED	RESERVED
	0	0	RW	N	RESERVED	RESERVED
0x09		0x00				
	7	0	RW	N	RESERVED	RESERVED
	6	0	RW	N	RESERVED	RESERVED
	5	0	RW	N	RESERVED	RESERVED
	4	0	RW	N	RESERVED	RESERVED
	3	0	RW	N	RESERVED	RESERVED
	2	0	RW	N	RESERVED	RESERVED
	1	0	RW	N	RESERVED	RESERVED
	0	0	RW	N	RESERVED	RESERVED
0x0A		0x30				
	7	0	RW	N	RESERVED	RESERVED
	6	0	RW	Y	SD_EN_FAST	1: Fast signal detect enabled. 0: Fast signal detect disabled.
	5	1	RW	Y	SD_REF_HIGH	Signal detect threshold controls: 11: Normal operation
	4	1	RW	Y	SD_GAIN	10: Signal detect assert or de-assert thresholds reduced. 01: Signal detect assert or de-assert thresholds reduced. 00: Signal detect assert or de-assert thresholds reduced.
	3	0	RW	N	RESERVED	RESERVED
	2	0	RW	N	RESERVED	RESERVED
	1	0	RW	N	RESERVED	RESERVED
	0	0	RW	N	RESERVED	RESERVED
0x0B		0x1A				
	7	0	RW	N	RESERVED	RESERVED
	6	0	RW	N	RESERVED	RESERVED
	5	0	RW	N	RESERVED	RESERVED
	4	1	RW	Y	RESERVED	RESERVED
	3	1	RW	Y	RESERVED	RESERVED

表 8-4. Channel Register Map (continued)

Addr [HEX]	Bit	Default [HEX]	Mode	EEPROM	Field	Description
	2	0	RW	Y	RESERVED	RESERVED
	1	1	RW	Y	RESERVED	RESERVED
	0	0	RW	Y	RESERVED	RESERVED
0x0C		0x00				
	7	0	RW	N	RESERVED	RESERVED
	6	0	RW	N	RESERVED	RESERVED
	5	0	RW	N	RESERVED	RESERVED
	4	0	RW	N	RESERVED	RESERVED
	3	0	RW	Y	RESERVED	RESERVED
	2	0	RW	Y	RESERVED	RESERVED
	1	0	RW	Y	RESERVED	RESERVED
	0	0	RW	Y	RESERVED	RESERVED
0x0D		0x00				
	7	0	RW	N	RESERVED	RESERVED
	6	0	RW	N	RESERVED	RESERVED
	5	0	RW	N	RESERVED	RESERVED
	4	0	RW	N	RESERVED	RESERVED
	3	0	RW	Y	RESERVED	RESERVED
	2	0	RW	Y	RESERVED	RESERVED
	1	0	RW	Y	RESERVED	RESERVED
	0	0	RW	Y	RESERVED	RESERVED
0x0E		0x00				
	7	0	RW	N	RESERVED	RESERVED
	6	0	RW	N	RESERVED	RESERVED
	5	0	RW	N	RESERVED	RESERVED
	4	0	RW	N	RESERVED	RESERVED
	3	0	RW	N	RESERVED	RESERVED
	2	0	RW	N	RESERVED	RESERVED
	1	0	RW	N	RESERVED	RESERVED
	0	0	RW	N	RESERVED	RESERVED
0x0F		0x00				
	7	0	RW	N	RESERVED	RESERVED
	6	0	RW	N	RESERVED	RESERVED
	5	0	RW	Y	BG_SEL_IPP100[1]	CTLE bias programming. BG_SEL_IPP100[2] is in Reg_0x04[1]. 00: 0% additional current (Default) 001: 5% additional current 010: 10% additional current 011: 15% additional current 100: 20% additional current 101: 25% additional current 110: 30% additional current 111: 35% additional current
	4	0	RW	Y	BG_SEL_IPP100[0]	
	3	0	RW	Y	BG_SEL_IPH200_v1[1]	Program pre-driver bias current: 00: 0% additional current (Default) 01: 12.5% additional current 10: 25% additional current 11: 37.5% additional current
	2	0	RW	Y	BG_SEL_IPH200_v1[0]	
	1	0	RW	Y	BG_SEL_IPH200_v0[1]	Program driver bias current: 00: 0% additional current (Default) 01: 12.5% additional current 10: 25% additional current 11: 37.5% additional current
	0	0	RW	Y	BG_SEL_IPH200_v0[0]	
0x10		0x00				
	7	0	RW	N	RESERVED	RESERVED

表 8-4. Channel Register Map (continued)

Addr [HEX]	Bit	Default [HEX]	Mode	EEPROM	Field	Description
	6	0	RW	N	RESERVED	RESERVED
	5	0	RW	Y	RESERVED	RESERVED
	4	0	RW	Y	RESERVED	RESERVED
	3	0	RW	Y	RESERVED	RESERVED
	2	0	RW	Y	RESERVED	RESERVED
	1	0	RW	Y	RESERVED	RESERVED
	0	0	RW	Y	RESERVED	RESERVED
0x11-0x19		0x00				
	7	0	RW	N	RESERVED	RESERVED
	6	0	RW	N	RESERVED	RESERVED
	5	0	RW	N	RESERVED	RESERVED
	4	0	RW	N	RESERVED	RESERVED
	3	0	RW	N	RESERVED	RESERVED
	2	0	RW	N	RESERVED	RESERVED
	1	0	RW	N	RESERVED	RESERVED
	0	0	RW	N	RESERVED	RESERVED

9 Application and Implementation

备注

Information in the following applications sections is not part of the TI component specification, and TI does not warrant its accuracy or completeness. TI's customers are responsible for determining suitability of components for their purposes. Customers should validate and test their design implementation to confirm system functionality.

9.1 Application Information

The DS280MB810 is a high-speed linear repeater which extends the reach of differential channels impaired by loss from transmission media like PCBs and cables while simultaneously providing signal distribution. It can be deployed in a variety of systems from backplanes and mid-planes to front ports and chip-to-chip interfaces. The following sections outline typical applications and their associated design considerations.

9.2 Typical Application

The DS280MB810 with integrated cross-point is typically used in two main application scenarios:

1. Backplane, mid-plane, and chip-to-chip reach extension
2. Front-port eye opening for copper and optical applications



图 9-1. Typical application block diagram

备注

TI recommends to AC couple the DS280MB810's high-speed outputs. In some cases, ASIC or FPGA SerDes receivers support DC coupling, and it may be desirable to DC couple the DS280MB810 output with the ASIC/FPGA RX input to reduce the PCB area which would normally be consumed by AC coupling capacitors. To DC couple the DS280MB810 output with an ASIC RX input, the ASIC RX must support DC coupling and it must support an input common mode voltage of 1.05 V. To determine if the ASIC RX supports DC coupling, here are some items to consider based on 图 9-2:

- 1.
1. The ASIC RX must be AC coupled on-chip.
2. The ASIC RX should not force a DC bias on the RX pins.
3. System designers should ensure that when the PCB powers on, the power supply rails are appropriately sequenced to prevent the DS280MB810's output common mode voltage from forward-biasing the ESD structure of the ASIC or violating the absolute maximum input voltage specifications of the ASIC.

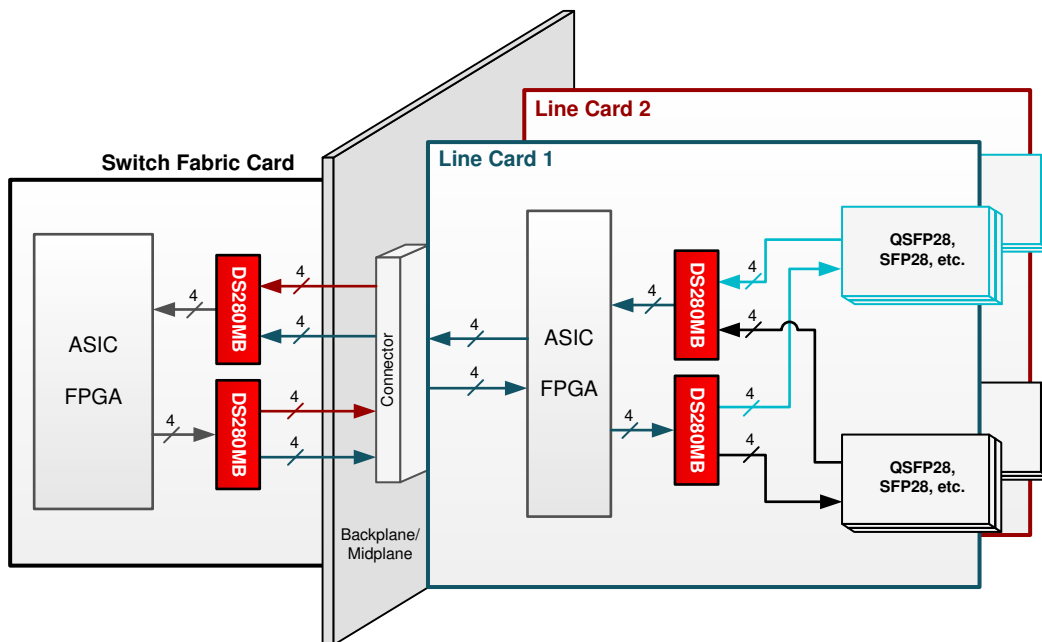

图 9-2. Considerations for DC coupling to ASIC RX

9.2.1 Backplane and Mid-Plane Reach Extension

The DS280MB810 has strong equalization capabilities that allow it to equalize insertion loss and extend the reach of backplane channels by 17+ dB beyond the normal capabilities of the ASICs operating over the channel. The DS280MB810 is designed to apply gain in a linear fashion. Whenever system design constraints allow, the DS280MB810 should be placed with the higher loss channel segment at the input and the lower loss channel segment at the output; however, since the DS280MB810 operates in a linear fashion, it can also be used in applications where the lower loss channel segment is at the input and the higher loss channel segment is at the output. 图 9-3 shows a typical backplane and mid-plane configuration using the DS280MB810 to perform equalization and signal distribution for failover or redundancy. 图 9-4 shows the corresponding simplified schematic for this application.

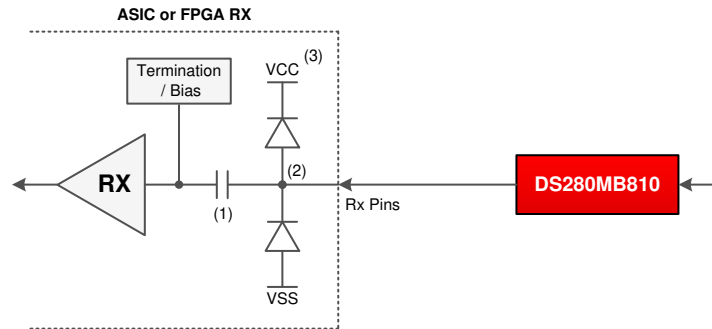

图 9-3. Typical backplane and mid-plane application block diagram



图 9-4. Typical backplane and mid-plane simplified schematic

9.2.1.1 Design Requirements

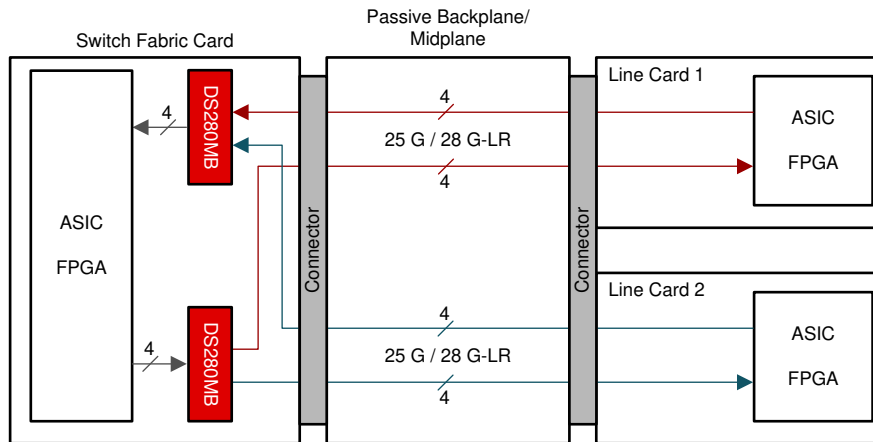
For backplane, mid-plane, and chip-to-chip reach extension applications, use the guidelines in the table below.

DESIGN PARAMETER	REQUIREMENT
AC coupling capacitors	Generally not required. 220-nF AC coupling capacitors are included in the DS280MB810 package on the RX side.
Input channel insertion loss	≥ 10 dB at 14 GHz as a rough guideline. For best performance, the input channel insertion loss should be greater than or equal to the equalizer boost setting used in the DS280MB810.
Output channel insertion loss	Depends on downstream ASIC or FPGA SerDes capabilities. Should be ≥ 5 dB at 14 GHz as a rough guideline.
Total (input + output) channel insertion loss	Depends on downstream ASIC or FPGA SerDes capabilities. The DS280MB810 can extend the reach between two ASICs by 17+ dB <i>beyond the ASICs' normal capabilities</i> .
Link partner TX launch amplitude	800 mV _{PP} to 1200 mV _{PP} differential
Link partner TX FIR filter	Depends on the channel loss.

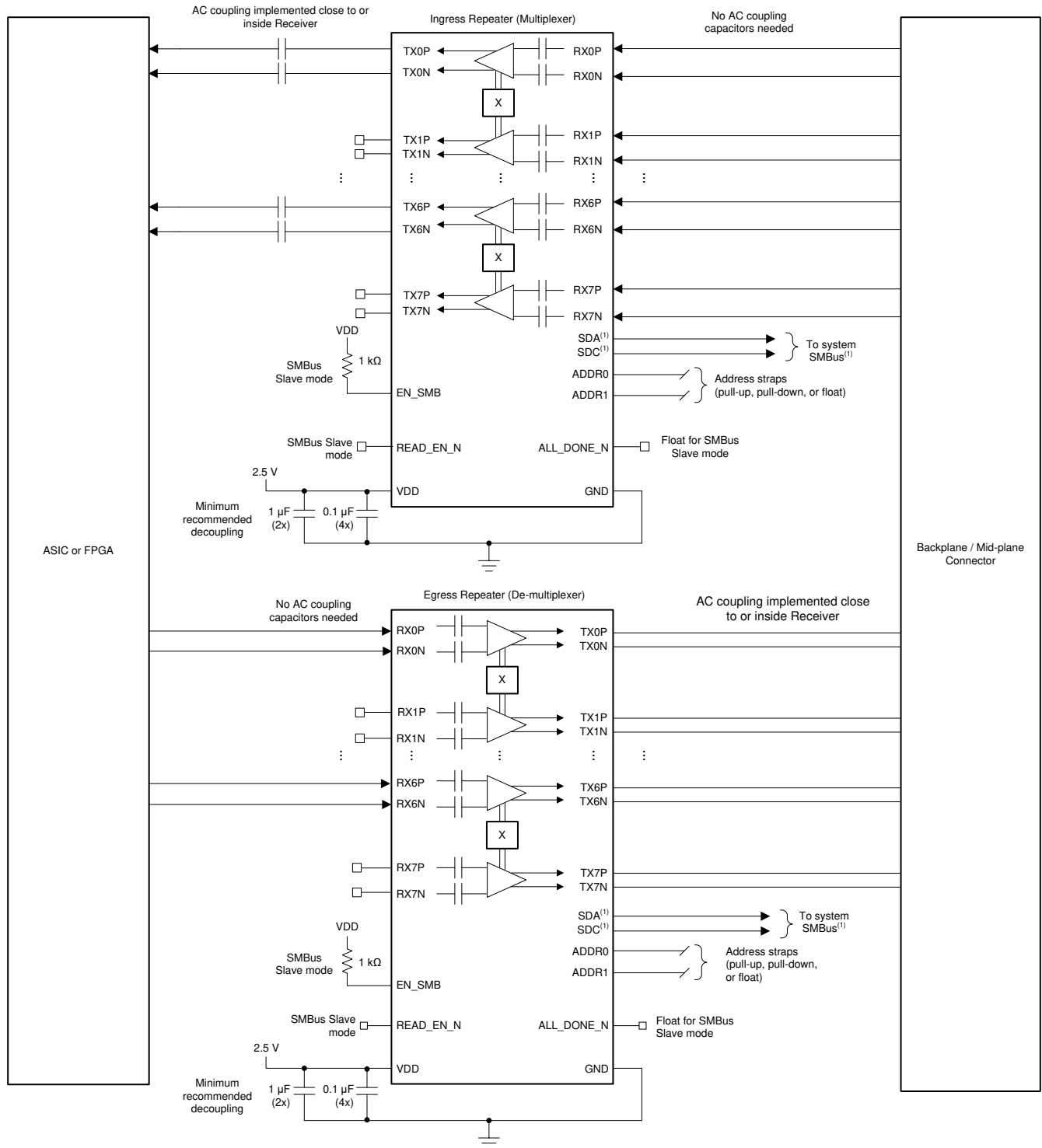
9.2.1.2 Detailed Design Procedure

The design procedure for backplane and mid-plane applications is as follows:

- Determine the total number of channels on the board which require a DS280MB810 for signal conditioning. This will dictate the total number of DS280MB810 devices required for the board. It is generally recommended that channels with similar total insertion loss on the board be grouped together in the same DS280MB810 device. This will simplify the device settings, as similar loss channels generally utilize similar settings.
- Determine the maximum current draw required for all DS280MB810 devices. This may impact the selection of the regulator for the 2.5-V supply rail. To calculate the maximum current draw, multiply the maximum power supply current by the total number of DS280MB810 devices.
- Determine the SMBus address scheme needed to uniquely address each DS280MB810 device on the board, depending on the total number of devices identified in step 1. Each DS280MB810 can be strapped with one of 16 unique SMBus addresses. If there are more DS280MB810 devices on the board than the number of unique SMBus addresses which can be assigned, then use an I²C expander like the TCA/PCA family of I²C/SMBus switches and multiplexers to split the SMBus into multiple busses.
- Determine if the device will be configured from EEPROM (SMBus master mode) or from the system SMBus (SMBus slave mode).
 - If SMBus master mode will be used, provisions should be made for an EEPROM on the board with 8-bit SMBus address 0xA0. Refer to [§ 8.4.2](#) for more details on SMBus Master Mode including EEPROM size requirements.
 - If SMBus slave mode will be used for all device configurations, an EEPROM is not needed.
- Make provisions in the schematic and layout for standard decoupling capacitors between the device VDD supply and GND. Refer to [§ 10](#) for more information.
- If there is a need to potentially upgrade to a pin-compatible TI Retimer device, then make provisions in the schematic and layout for a 25-MHz (± 100 ppm) single-ended CMOS clock. Each DS280MB810 buffers the clock on the CAL_CLK_IN pin and presents the buffered clock on the CAL_CLK_OUT pin. This allows multiple (up to 20) DS280MB810 calibration clocks to be daisy chained to avoid the need for multiple oscillators on the board. If the oscillator used on the board has a 2.5-V CMOS output, then no AC coupling capacitor or resistor ladder is required at the input to CAL_CLK_IN. No AC coupling or resistor ladder is needed between one DS280MB810 CAL_CLK_OUT output and the next DS280MB810's CAL_CLK_IN input. The final DS280MB810's CAL_CLK_OUT output can be left floating. A 25 MHz clock is not required for the DS280MB810, but it is good practice to provision for it in case there is a future plan to upgrade to a pin-compatible TI Retimer device.
- If there is a need to potentially upgrade to a pin-compatible TI Retimer device, then connect the INT_N pin to an FPGA or CPU for interrupt monitoring. Note that multiple INT_N outputs can be connected together. The common INT_N net should be pulled high to 2.5 V or 3.3 V. The INT_N pin on the DS280MB810 does not

perform the interrupt functionality that the equivalent pin on the pin-compatible Retimer device does; however, it is good practice to provision for this in case there is a future plan to upgrade to a pin-compatible TI Retimer device.

9.2.2 Front-Port Applications

The DS280MB810 has strong equalization capabilities that allow it to equalize insertion loss and extend the reach of front-port channels by 17 dB beyond the normal capabilities of the ASIC while supporting CAUI-4 and CR4 electrical requirements. The DS280MB810 is designed to apply gain in a linear fashion in order to support longer distances between the switch ASIC and the front-port module. Figure 9-5 illustrates a configuration where two DS280MB810s are used to mux between one QSFP28 port and four SFP28 ports. Figure 9-9 shows the simplified schematic for this application.



图 9-5. Front-port application block diagram

Standard front-port modules have AC coupling capacitors included inside the module. The DS280MB810, therefore, is ideal for front-port Egress signal conditioning applications since it includes AC coupling capacitors on the input (RX) side and does not include AC coupling capacitors on the output (TX) side.

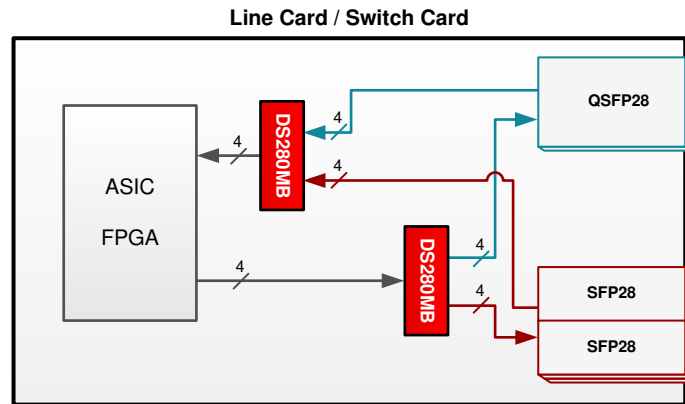

图 9-6. DS280MB810 recommended for front-port Egress

The optimum solution for front-port Ingress signal conditioning applications depends on whether the ASIC RX supports DC coupling and whether it can support an input common mode voltage of 1.05 V. For further guidance on determining if the ASIC RX supports DC coupling, refer to Figure 9-2. If the ASIC RX supports DC coupling and can tolerate an input common mode voltage of 1.05-V or less, then the DS280MB810 is the optimum solution for front-port Ingress signal conditioning. If the ASIC RX does not support DC coupling or cannot tolerate an input common mode voltage of 1.05-V, then the pin-compatible DS280DF810 Retimer with cross-point, which has integrated AC Coupling capacitors on both RX and TX, may be the optimum solution.



图 9-7. DS280MB810 recommended for front-port Ingress



图 9-8. DS280MB810 or DS280DF810 recommended for front-port Ingress

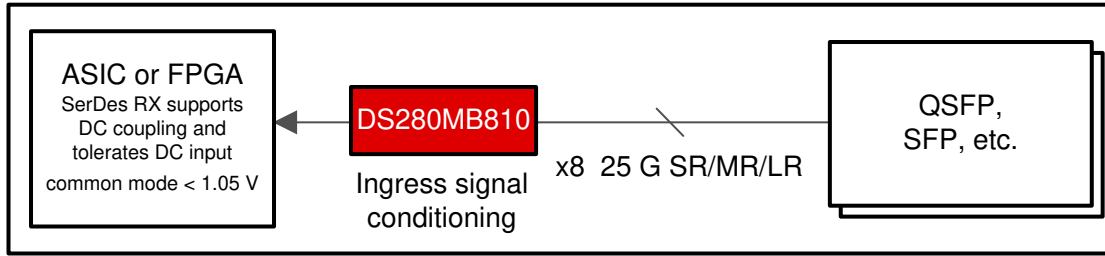

图 9-9. Front-port application simplified schematic

9.2.2.1 Design Requirements

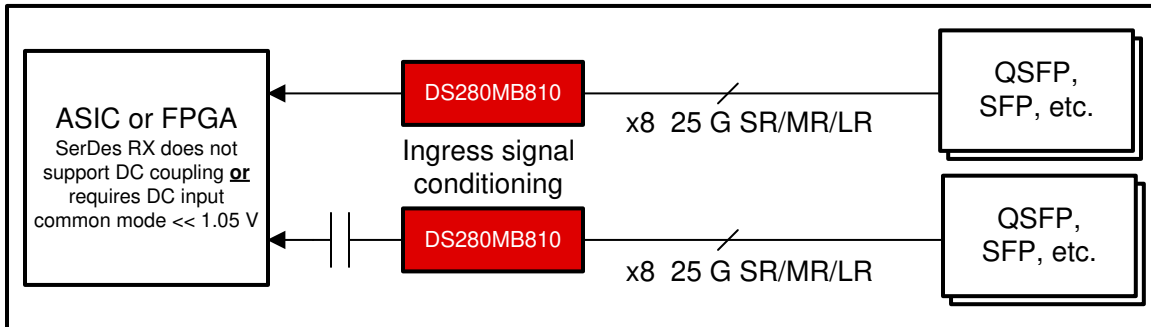
For front-port reach extension and signal distribution applications, use the guidelines in the table below.

DESIGN PARAMETER	REQUIREMENT
AC Coupling Capacitors	Generally not required. 220-nF AC coupling capacitors are included in the DS280MB810 package on the RX side.
Input Channel Insertion Loss	≥ 10 dB at 14 GHz as a <i>rough</i> guideline. For best performance, the input channel insertion loss should be greater than or equal to the equalizer boost setting used in the Repeater.
Output Channel Insertion Loss	For best performance in <i>egress</i> applications, place the Repeater close to the front-port cage. For best performance in <i>ingress</i> applications, place the Repeater with ≥ 5 dB loss at 14 GHz between the output and the downstream ASIC.
Switch ASIC TX Launch Amplitude	600 mVppd to 1000 mVppd

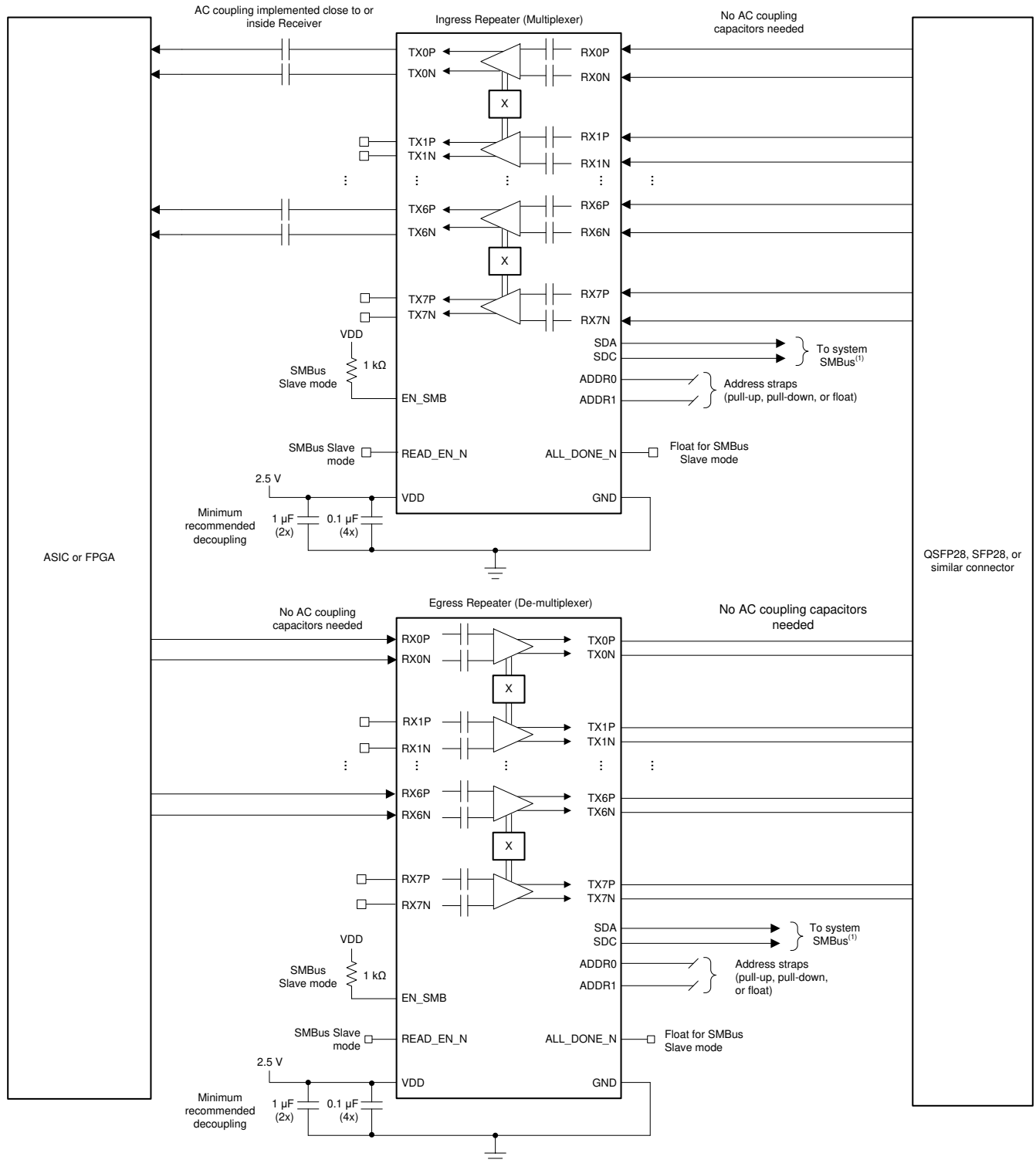
9.2.2.2 Detailed Design Procedure

The design procedure for front-port applications is as follows:

- Determine the total number of channels on the board which require a DS280MB810 for signal conditioning. This will dictate the total number of DS280MB810 devices required for the board. It is generally recommended that channels belonging to the same port be grouped together in the same DS280MB810 device. This will simplify the device settings, as similar loss channels generally utilize similar settings.
- Determine the maximum current draw required for all DS280MB810 devices. This may impact the selection of the regulator for the 2.5-V supply rail. To calculate the maximum current draw, multiply the maximum power supply current by the total number of DS280MB810 devices.
- Determine the SMBus address scheme needed to uniquely address each DS280MB810 device on the board, depending on the total number of devices identified in step 1. Each DS280MB810 can be strapped with one of 16 unique SMBus addresses. If there are more DS280MB810 devices on the board than the number of unique SMBus addresses which can be assigned, then use an I²C expander like the TCA/PCA family of I²C/SMBus switches and multiplexers to split the SMBus into multiple busses.
- Determine if the device will be configured from EEPROM (SMBus master mode) or from the system I²C bus (SMBus slave mode).
 - If SMBus master mode will be used, provisions should be made for an EEPROM on the board with 8-bit SMBus address 0xA0. Refer to [节 8.4.2](#) for more details on SMBus Master Mode including EEPROM size requirements.
 - If SMBus slave mode will be used for all device configurations, an EEPROM is not needed.
- Make provisions in the schematic and layout for standard decoupling capacitors between the device VDD supply and GND. Refer to [节 10](#) for more information.

9.2.3 Application Curves

9.2.3.1 Pattern Generator Characteristics

All of the example application results in the sections which follow were tested using a pattern generator with the following characteristics.



图 9-10. Pattern Generator test setup

图 9-11. Pattern Generator output at 25.78125 Gbps, 800m Vppd, PRBS9	图 9-12. Pattern Generator output at 10.31250 Gbps, 800 mVppd, PRBS9
---	---

表 9-1. Pattern Generator Characteristics

	25.78125 Gbps	10.3125 Gbps
Differential peak-to-peak voltage (VOD)	~800 mVppd	~800 mVppd
Channel loss between Pattern Generator and Scope	2 dB @ 12.9 GHz	1 dB @ 5.2 GHz
Total Jitter @ 1E-15	8.0 pSp,p	13.4 pSp,p
Differential Eye Height @ 1E-15	448 mVp,p	596 mVp,p

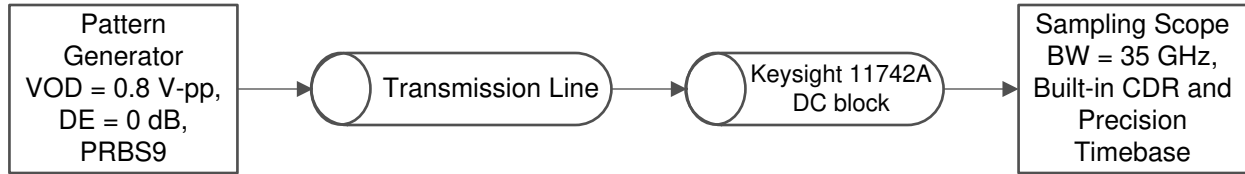
9.2.3.2 Equalizing Moderate Pre-Channel Loss

This example application result demonstrates the DS280MB810 equalizing for pre-channel insertion loss introduced by an FR4 channel.



图 9-13. 5 in input channel and minimal output channel test setup



表 9-2. Settings and Measurements for CAUI-4 and nPPI with 5 in input channel and minimal output channel

	25.78125 Gbps (CAUI-4)	10.3125 Gbps (nPPI)
Transmission Line 1	5 in 5 mil FR4 + 8 in SMA cable	5 in 5 mil FR4 + 8 in SMA cable
DS280MB810 Rx Channel Loss	14 dB @ 12.9 GHz	6 dB @ 5.2 GHz
DS280MB810 Tx Channel Loss	4.5 dB @ 12.9 GHz	2 dB @ 5.2 GHz
EQ BST1	3	3
EQ BST2	0	0
EQ BW	3	3
VOD	3	2
EQ DC Gain Mode	Low	Low
Total Jitter @ 1E-15	11.9 ps _{P-P}	13.0 ps _{P-P}
Differential Eye Height @ 1E-15	338 mV _{P-P}	544 mV _{P-P}
Mask violations	0	0

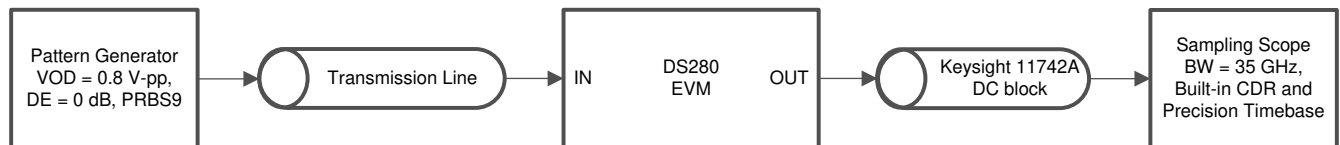
9.2.3.3 Equalizing High Pre-Channel Loss

This example application result demonstrates the DS280MB810 equalizing for pre-channel insertion loss introduced by an FR4 channel.

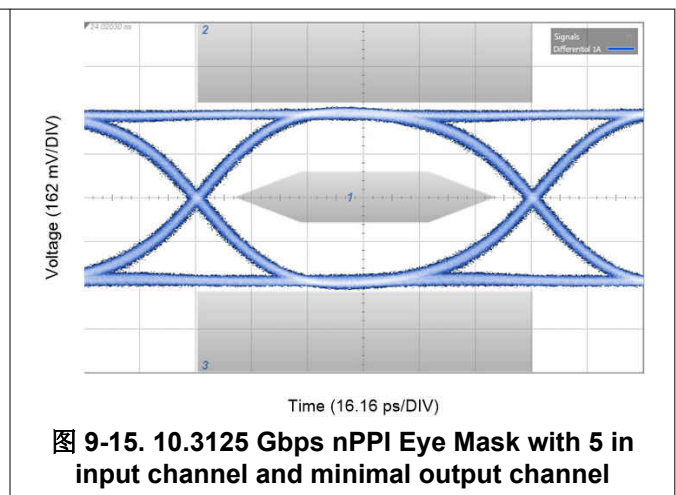
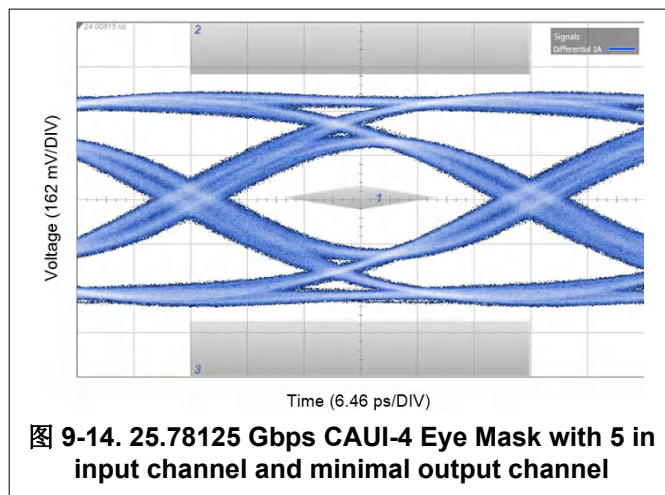

图 9-16. 10 in input channel and minimal output channel test setup

图 9-17. 25.78125 Gbps CAUI-4 Eye Mask with 10 in input channel and minimal output channel

图 9-18. 10.3125 Gbps nPPI Eye Mask with 10 in input channel and minimal output channel

表 9-3. Settings and Measurements for CAUI-4 and nPPI with 10 in input channel and minimal output channel

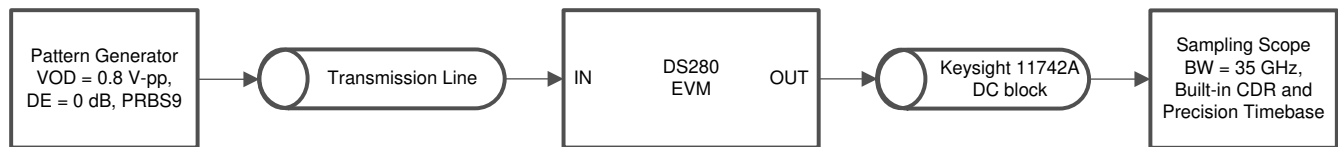
	25.78125 Gbps (CAUI-4)	10.3125 Gbps (nPPI)
Transmission Line 1	10 in 5 mil FR4 + 8 in SMA cable	10 in 5 mil FR4 + 8 in SMA cable
DS280MB810 Rx Channel Loss	22 dB @ 12.9 GHz	10 dB @ 5.2 GHz
DS280MB810 Tx Channel Loss	4.5 dB @ 12.9 GHz	2 dB @ 5.2 GHz
EQ BST1	6	6
EQ BST2	1	1
EQ BW	3	3
VOD	3	2
EQ DC Gain Mode	Low	Low
Total Jitter @ 1E-15	11.3 ps _{P-P}	13.5 ps _{P-P}
Differential Eye Height @ 1E-15	210 mV _{P-P}	532 mV _{P-P}
Mask violations	0	0

9.2.3.4 Equalizing High Pre-Channel Loss and Moderate Post-Channel Loss

This example application result demonstrates the DS280MB810 equalizing for pre-channel and post-channel insertion loss introduced by FR4 channels.



图 9-19. 10 in input channel and 5 in output channel test setup



图 9-20. 25.78125 Gbps Eye Diagram with 10 in input channel and 5 in output channel, Linear mode

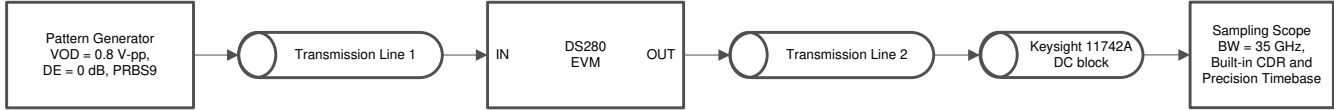

图 9-21. 10.3125 Gbps nPPI Eye Mask with 10 in input channel and 5 in output channel

表 9-4. Settings and Measurements for CAUI-4 and nPPI with 10 in input channel and 5 in output channel

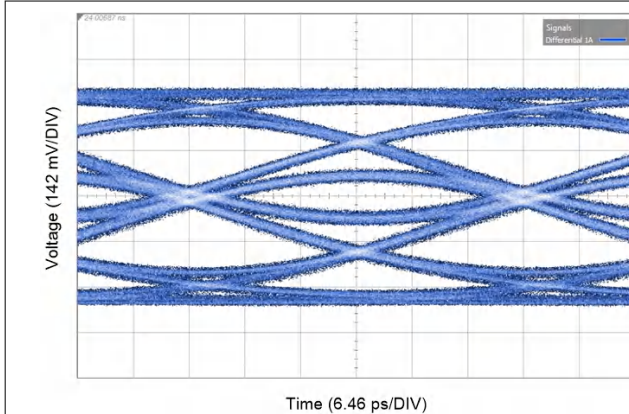
	25.78125 Gbps (CAUI-4)	10.3125 Gbps (nPPI)
Transmission Line 1	10 in 5 mil FR4 + 8 in SMA cable	10 in 5 mil FR4 + 8 in SMA cable
Transmission Line 2	5 in 5 mil FR4 + 8 in SMA cable	5 in 5 mil FR4 + 8 in SMA cable
DS280MB810 Rx Channel Loss	22 dB @ 12.9 GHz	10 dB @ 5.2 GHz
DS280MB810 Tx Channel Loss	14.5 dB @ 12.9 GHz	6 dB @ 5.2 GHz
EQ BST1	7	7
EQ BST2	7	7
EQ BW	3	3
VOD	3	2
EQ DC Gain Mode	Low	Low
Total Jitter @ 1E-15	14.8 ps _{P-P}	17.0 ps _{P-P}
Differential Eye Height @ 1E-15	67 mV _{P-P}	407 mV _{P-P}
Mask violations	N/A	0

9.3 Initialization Set Up

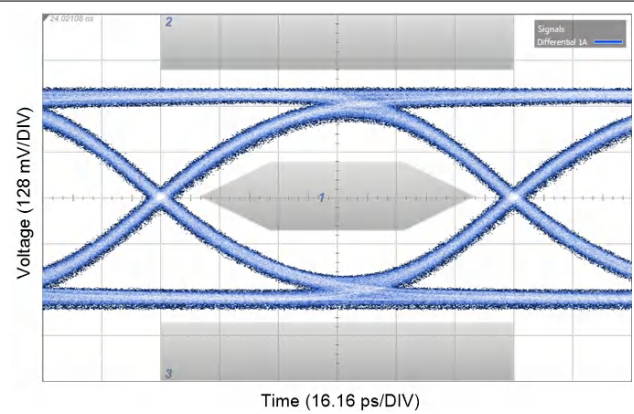
The DS280MB810 does not require any particular start-up or initialization sequence. The device defaults to a medium boost value for each channel. It is recommend that the channels be appropriately configured before data traffic is transmitted to the DS280MB810 to avoid issues with the link partner ASIC's adaption. If using pin-mode to control the cross-point switch (Shared Reg_0x05[1]=1), it is recommended that the mux and fanout configuration be set before data traffic is transmitted so that the desired signal routing and distribution is achieved. Example configuration settings can be found in the DS280MB810 Programming Guide.

10 Power Supply Recommendations

Follow these general guidelines when designing the power supply:

1. The power supply should be designed to provide the recommended operating conditions outlined in the 节 7 Section in terms of DC voltage, AC noise, and start-up ramp time.

2. The maximum current draw for the DS280MB810 is provided in the [节 7](#) Section. This figure can be used to calculate the maximum current the supply must provide. Typical mission-mode current draw can be inferred from the typical power consumption in the [节 7](#) Section.
3. The DS280MB810 **does not** require any special power supply filtering, such as ferrite beads, provided the recommended operating conditions are met. Only standard supply decoupling is required. Typical supply decoupling consists of a 0.1- μ F capacitor per power pin, and single 1.0- μ F and 10- μ F bulk capacitors.

11 Layout

11.1 Layout Guidelines

The following guidelines should be followed when designing the layout:

1. Decoupling capacitors should be placed as close to the VDD pins as possible. Placing them directly underneath the device is one option if the board design permits.
2. High-speed differential signals should be tightly coupled, skew matched, and impedance controlled.
3. Vias should be avoided when possible on the high-speed differential signals. When vias must be used, care should be taken to minimize the via stub, either by transitioning through most or all layers, or by back drilling.
4. GND relief can be used beneath the high-speed differential signal pads to improve signal integrity by counteracting the pad capacitance.
5. GND vias should be placed directly beneath the device connecting the GND plane attached to the device to the GND planes on other layers. This has the added benefit of improving thermal conductivity from the device to the board.
6. BGA landing pads for a 0.8 mm pitch flip-chip BGA are typically 0.4 mm in diameter (exposed). The actual size of the copper pad will depend on whether solder-mask-defined (SMD) or non-solder-mask-defined solder land pads are used. For more information, refer to TI's Surface Mount Technology (SMT) References website.

11.2 Layout Examples

11.2.1 Stripline Example

The following example layout demonstrates how all signals can be escaped from the BGA array using stripline routing on a generic 8+ layer stackup. This example layout assumes the following:

- Trace width: 0.15 mm (6 mil)
- Trace edge-to-edge spacing: 0.16 mm (6.4 mil)
- VIA finished hole size (diameter): 0.254 mm (10 mil)
- VIA-to-VIA spacing: 1.0 mm (39 mil), to enhance PCB manufacturability
- No VIA-in-pad used

Note that many other escape routing options exist using different trace width and spacing combinations. The optimum trace width and spacing will depend on the PCB material, PCB routing density, and other factors. Microstrip escape routing is also possible and may be preferable in some application scenarios such as front-port applications.



图 11-1. Stripline example, Top Layer



图 11-2. Stripline example, Internal Signal Layer 1

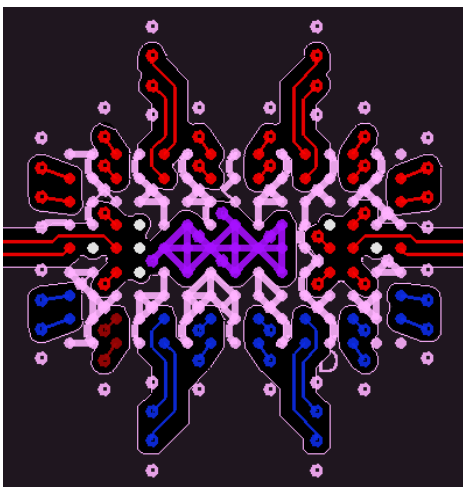

图 11-3. Stripline example, Internal Signal Layer 2

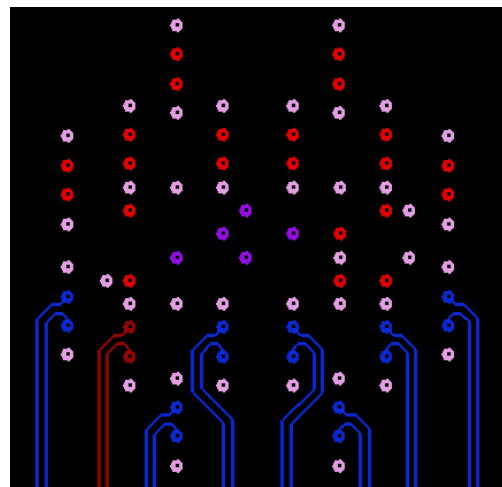

图 11-4. Stripline example, Bottom Layer

11.2.2 Microstrip Example

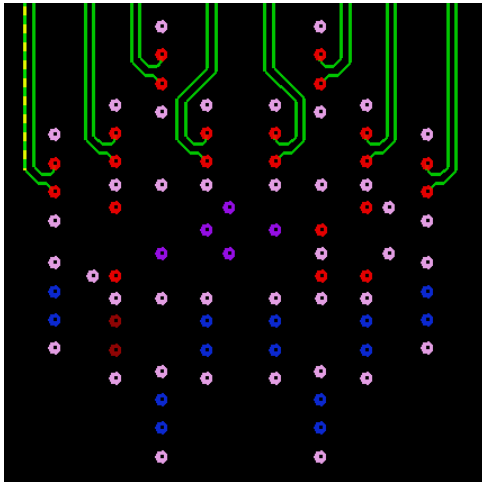
The following example layout demonstrates how all signals can be escaped from the BGA array using microstrip routing on a generic 8+ layer stackup. This example layout assumes the following:

- Normal trace width: 0.27 mm (10.5 mil)
- Neck-down trace width: 0.18 mm (7 mil)
- Trace edge-to-edge spacing: 0.51 mm (20 mil)
- VIA finished hole size (diameter): 0.203 mm (8 mil)
- VIA-to-VIA spacing: 0.8 mm (31.5 mil)
- No VIA-in-pad used

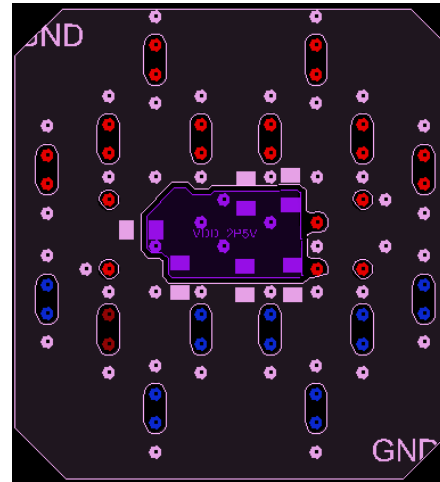
Note that many other escape routing options exist using different trace width and spacing combinations. The optimum trace width and spacing will depend on the PCB material, PCB routing density, and other factors. Stripline escape routing is also possible and may be preferable in some application scenarios such as backplane applications.



图 11-5. Microstrip Example, Top Layer



图 11-6. Microstrip Example, Internal Signal Layer 1

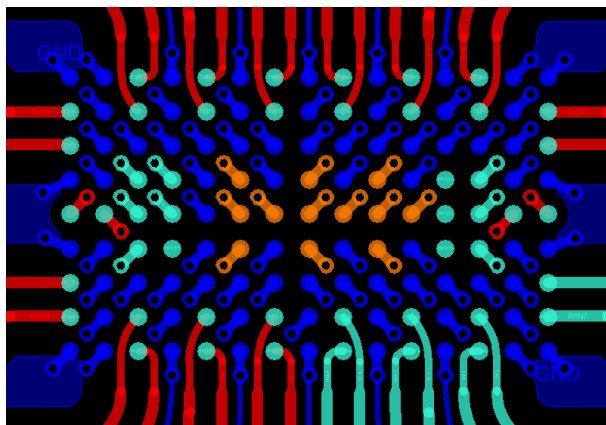

图 11-7. Microstrip Example, Internal Signal Layer 2

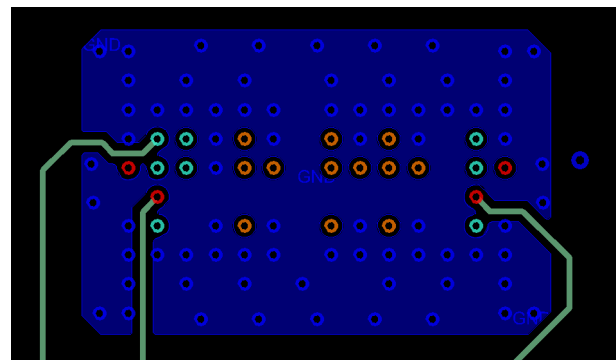

图 11-8. Microstrip Example, Bottom Layer

12 Device and Documentation Support

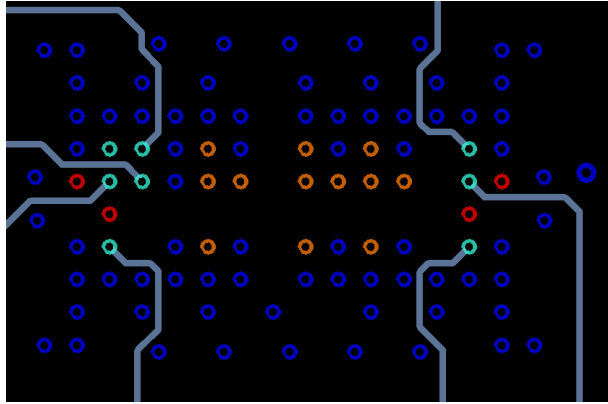
12.1 Documentation Support

12.1.1 Related Documentation

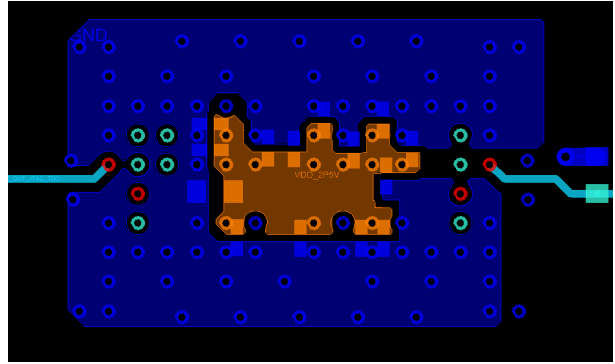
For related documentation see the following:

- Texas Instruments, [Selection Guide for TI 25G and 28G Retimers and Repeaters Application Report](#)
- Texas Instruments, [DS280MB810 Programmer's Guide](#)
- Texas Instruments, [DS280MB810EVM User's Guide](#)

12.2 Receiving Notification of Documentation Updates

To receive notification of documentation updates, navigate to the device product folder on ti.com. In the upper right corner, click on *Alert me* to register and receive a weekly digest of any product information that has changed. For change details, review the revision history included in any revised document.

12.3 Support Resources

12.4 Trademarks

所有商标均为其各自所有者的财产。

13 Mechanical, Packaging, and Orderable Information

The following pages include mechanical, packaging, and orderable information. This information is the most current data available for the designated devices. This data is subject to change without notice and revision of this document. For browser-based versions of this data sheet, refer to the left-hand navigation.

PACKAGING INFORMATION

Orderable part number	Status (1)	Material type (2)	Package Pins	Package qty Carrier	RoHS (3)	Lead finish/ Ball material (4)	MSL rating/ Peak reflow (5)	Op temp (°C)	Part marking (6)
DS280MB810ZBLR	Active	Production	NFBGA (ZBL) 135	1000 LARGE T&R	Yes	SNAGCU	Level-3-260C-168 HR	-40 to 85	DS280MB8
DS280MB810ZBLR.A	Active	Production	NFBGA (ZBL) 135	1000 LARGE T&R	Yes	SNAGCU	Level-3-260C-168 HR	-40 to 85	DS280MB8
DS280MB810ZBLT	Active	Production	NFBGA (ZBL) 135	250 SMALL T&R	Yes	SNAGCU	Level-3-260C-168 HR	-40 to 85	DS280MB8
DS280MB810ZBLT.A	Active	Production	NFBGA (ZBL) 135	250 SMALL T&R	Yes	SNAGCU	Level-3-260C-168 HR	-40 to 85	DS280MB8

(1) **Status:** For more details on status, see our [product life cycle](#).

(2) **Material type:** When designated, preproduction parts are prototypes/experimental devices, and are not yet approved or released for full production. Testing and final process, including without limitation quality assurance, reliability performance testing, and/or process qualification, may not yet be complete, and this item is subject to further changes or possible discontinuation. If available for ordering, purchases will be subject to an additional waiver at checkout, and are intended for early internal evaluation purposes only. These items are sold without warranties of any kind.

(3) **RoHS values:** Yes, No, RoHS Exempt. See the [TI RoHS Statement](#) for additional information and value definition.

(4) **Lead finish/Ball material:** Parts may have multiple material finish options. Finish options are separated by a vertical ruled line. Lead finish/Ball material values may wrap to two lines if the finish value exceeds the maximum column width.

(5) **MSL rating/Peak reflow:** The moisture sensitivity level ratings and peak solder (reflow) temperatures. In the event that a part has multiple moisture sensitivity ratings, only the lowest level per JEDEC standards is shown. Refer to the shipping label for the actual reflow temperature that will be used to mount the part to the printed circuit board.

(6) **Part marking:** There may be an additional marking, which relates to the logo, the lot trace code information, or the environmental category of the part.

Multiple part markings will be inside parentheses. Only one part marking contained in parentheses and separated by a "~" will appear on a part. If a line is indented then it is a continuation of the previous line and the two combined represent the entire part marking for that device.

Important Information and Disclaimer: The information provided on this page represents TI's knowledge and belief as of the date that it is provided. TI bases its knowledge and belief on information provided by third parties, and makes no representation or warranty as to the accuracy of such information. Efforts are underway to better integrate information from third parties. TI has taken and continues to take reasonable steps to provide representative and accurate information but may not have conducted destructive testing or chemical analysis on incoming materials and chemicals. TI and TI suppliers consider certain information to be proprietary, and thus CAS numbers and other limited information may not be available for release.

In no event shall TI's liability arising out of such information exceed the total purchase price of the TI part(s) at issue in this document sold by TI to Customer on an annual basis.

TAPE AND REEL INFORMATION

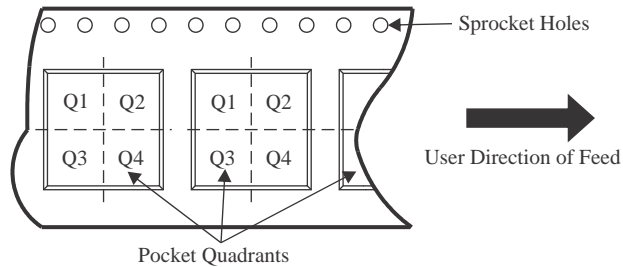
QUADRANT ASSIGNMENTS FOR PIN 1 ORIENTATION IN TAPE

*All dimensions are nominal

Device	Package Type	Package Drawing	Pins	SPQ	Reel Diameter (mm)	Reel Width W1 (mm)	A0 (mm)	B0 (mm)	K0 (mm)	P1 (mm)	W (mm)	Pin1 Quadrant
DS280MB810ZBLR	NFBGA	ZBL	135	1000	330.0	24.4	8.4	13.4	1.9	12.0	24.0	Q2
DS280MB810ZBLT	NFBGA	ZBL	135	250	178.0	24.4	8.4	13.4	1.9	12.0	24.0	Q2

TAPE AND REEL BOX DIMENSIONS

*All dimensions are nominal

Device	Package Type	Package Drawing	Pins	SPQ	Length (mm)	Width (mm)	Height (mm)
DS280MB810ZBLR	NFBGA	ZBL	135	1000	356.0	356.0	45.0
DS280MB810ZBLT	NFBGA	ZBL	135	250	213.0	191.0	55.0

ZBL0135A

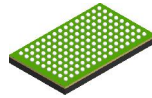

PACKAGE OUTLINE

NFBGA - 1.43 mm max height

PLASTIC BALL GRID ARRAY

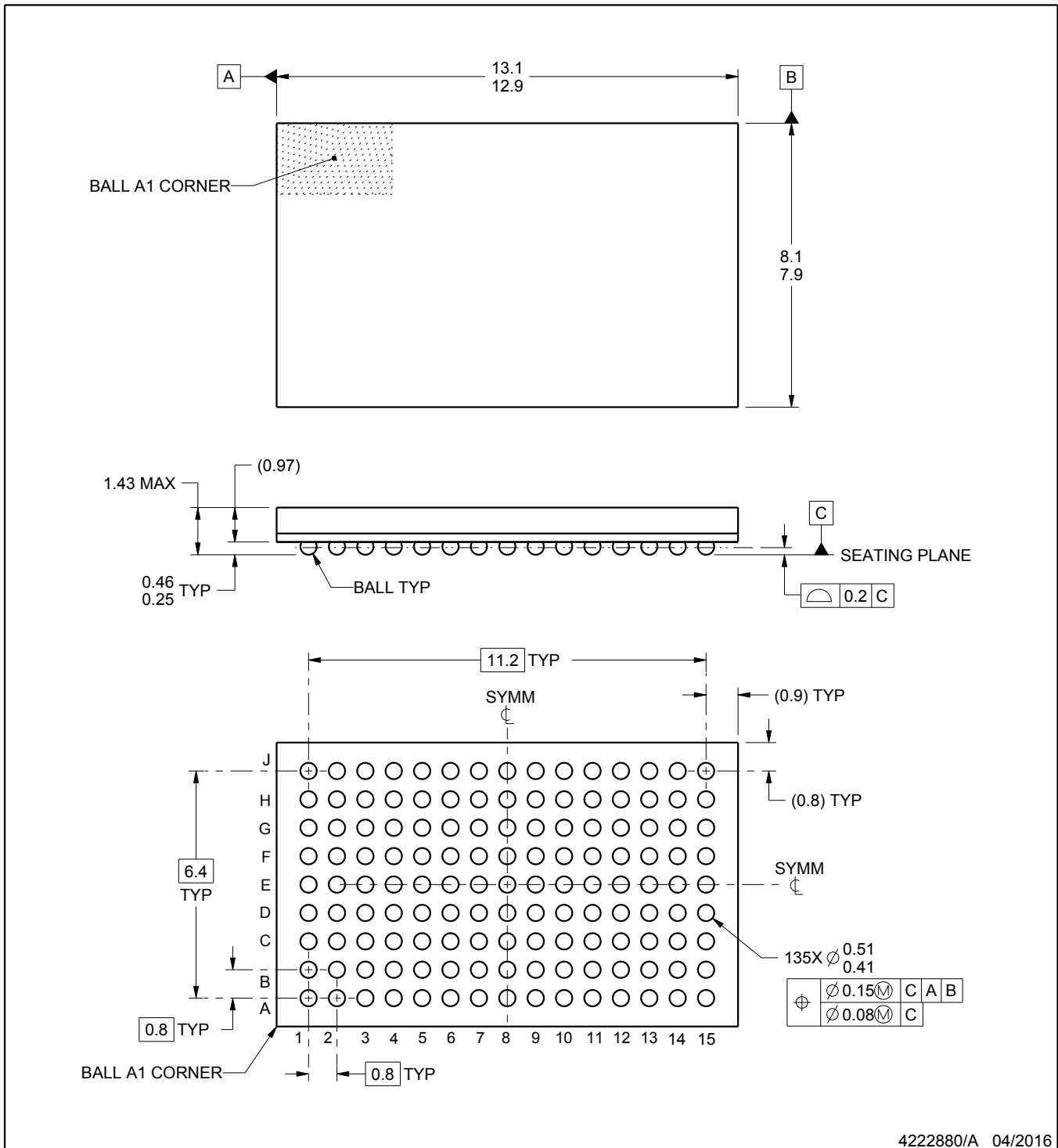

NOTES:

1. All linear dimensions are in millimeters. Any dimensions in parenthesis are for reference only. Dimensioning and tolerancing per ASME Y14.5M.
2. This drawing is subject to change without notice.

EXAMPLE BOARD LAYOUT

ZBL0135A

NFBGA - 1.43 mm max height

PLASTIC BALL GRID ARRAY

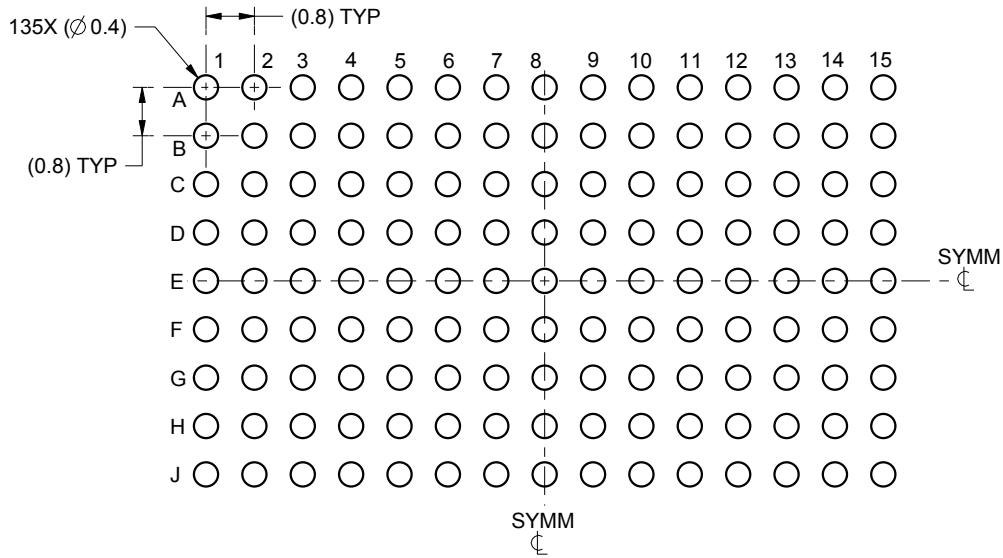

LAND PATTERN EXAMPLE
SCALE:8X

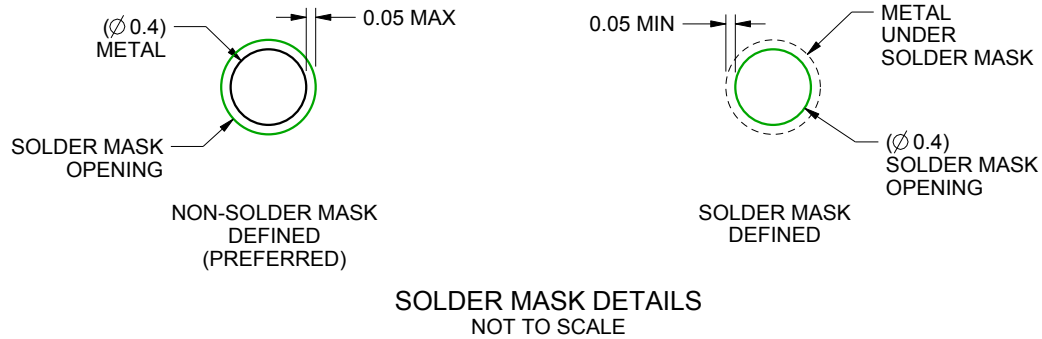

4222880/A 04/2016

NOTES: (continued)

- Final dimensions may vary due to manufacturing tolerance considerations and also routing constraints. For information, see Texas Instruments literature number SPRAA99 (www.ti.com/lit/spraa99).

EXAMPLE STENCIL DESIGN

ZBL0135A

NFBGA - 1.43 mm max height

PLASTIC BALL GRID ARRAY

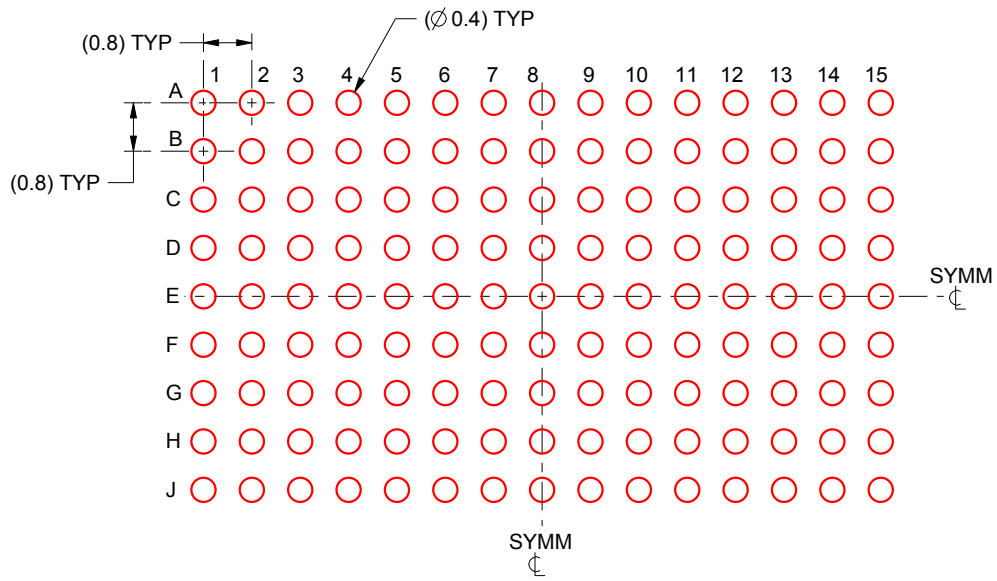

SOLDER PASTE EXAMPLE
BASED ON 0.15 mm THICK STENCIL
SCALE:8X

4222880/A 04/2016

NOTES: (continued)

4. Laser cutting apertures with trapezoidal walls and rounded corners may offer better paste release.

重要通知和免责声明

TI“按原样”提供技术和可靠性数据（包括数据表）、设计资源（包括参考设计）、应用或其他设计建议、网络工具、安全信息和其他资源，不保证没有瑕疵且不做任何明示或暗示的担保，包括但不限于对适销性、与某特定用途的适用性或不侵犯任何第三方知识产权的暗示担保。

这些资源可供使用 TI 产品进行设计的熟练开发人员使用。您将自行承担以下全部责任：(1) 针对您的应用选择合适的 TI 产品，(2) 设计、验证并测试您的应用，(3) 确保您的应用满足相应标准以及任何其他安全、安保法规或其他要求。

这些资源如有变更，恕不另行通知。TI 授权您仅可将这些资源用于研发本资源所述的 TI 产品的相关应用。严禁以其他方式对这些资源进行复制或展示。您无权使用任何其他 TI 知识产权或任何第三方知识产权。对于因您对这些资源的使用而对 TI 及其代表造成的任何索赔、损害、成本、损失和债务，您将全额赔偿，TI 对此概不负责。

TI 提供的产品受 [TI 销售条款](#)、[TI 通用质量指南](#) 或 [ti.com](#) 上其他适用条款或 TI 产品随附的其他适用条款的约束。TI 提供这些资源并不会扩展或以其他方式更改 TI 针对 TI 产品发布的适用的担保或担保免责声明。除非德州仪器 (TI) 明确将某产品指定为定制产品或客户特定产品，否则其产品均为按确定价格收入目录的标准通用器件。

TI 反对并拒绝您可能提出的任何其他或不同的条款。

版权所有 © 2026，德州仪器 (TI) 公司

最后更新日期：2025 年 10 月