

# 符合 WPC v1.2 标准并专有 10W 电力输送的 bq51025 单芯片无线电源接收器

## 1 特性

- 强大的 10W 接收器解决方案，使用专有协议与 TI 的 10W bq500215 发送器通信
  - 后置稳压 LDO，可保护外部充电器输入免受整流器输出瞬态影响；采用无电感器解决方案以实现最薄厚度
  - 可调节输出电压（4.5 至 10V），可实现线圈和热性能优化
  - 支持 2S 电池配置（不兼容 WPC）
  - 完全同步整流器的效率达 96%
  - 后置调节器的效率达 97%
  - 功率为 10W 时，系统效率可达 84%
- 符合 WPC v1.2 标准的通信和控制可实现与当前 TX 解决方案的兼容
- 已获专利的发送器板检测功能提升了用户体验
- 主机能够通过电源信号频率测量确定 TX 表面上的最佳放置位置
- 与主机进行 I<sup>2</sup>C 通信

## 2 应用范围

- 智能手机、平板电脑和头戴式耳机
- 销售点设备
- 2S 电池应用
- 移动电源
- 其它便携式设备

## 3 说明

bq51025 器件是一款全封闭式无线电源接收器，此接收器能够在无线电源联盟 (WPC) Qi 协议下运行，使无线电源系统在与 Qi 感应发送器配合使用时能够向系统传送 5W 功率，在与 bq500215 初级侧控制器配合使用时可传送高达 10W 功率。bq51025 器件可根据 WPC v1.2 规范提供单器件功率转换（整流和稳压）以及数字控制和通信。凭借市场领先的系统效率 (84%) 和可调输出电压，bq51025 器件可实现无与伦比的系统优化。bq51025 的输出电压最高可达 10V，能够灵活地为 2S 电池应用提供无线电源解决方案，并使系统散热性能达到最佳状态。I<sup>2</sup>C 接口可允许系统设计人员实现新功能，例如找正发送器表面上的接收器或检测接收器上的异物。bq51025 器件符合 WPC v1.2 通信协议，因此该器件能够与所有 WPC 发送器解决方案兼容。此接收器可在市场领先的封装、效率和解决方案尺寸中同时实现同步整流、稳压和控制与通信。

### 器件信息<sup>(1)</sup>

器件型号	封装	封装尺寸 (标称值)
bq51025	DSBGA (42)	3.60mm × 2.89mm

(1) 要了解所有可用封装，请见数据表末尾的可订购产品附录。

简化电路原理图

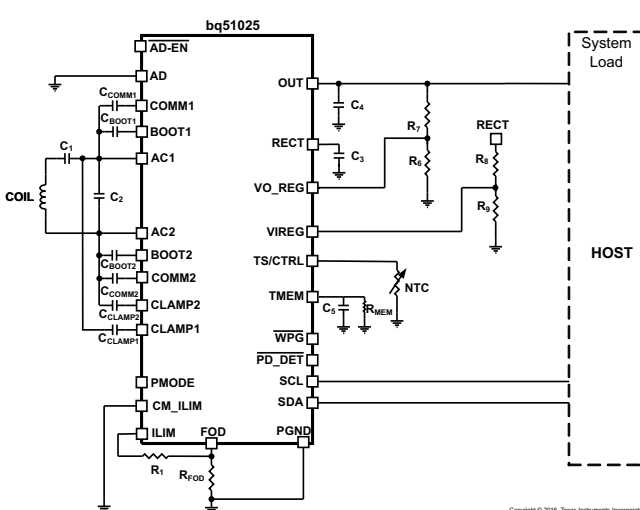

bq51025 使用 bq500215 TX 控制器时的系统效率

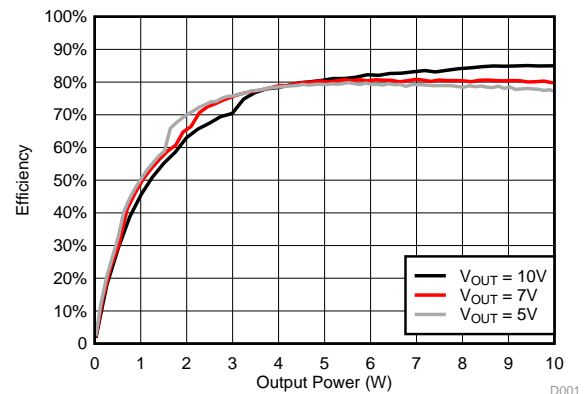

D001



## 目录

1	特性 .....	1	8.4	Device Functional Modes .....	18
2	应用范围 .....	1	8.5	Register Maps .....	21
3	说明 .....	1	<b>9</b>	<b>Application and Implementation .....</b>	<b>27</b>
4	修订历史记录 .....	2	9.1	Application Information .....	27
5	<b>Device Comparison Table .....</b>	<b>3</b>	9.2	Typical Applications .....	27
6	<b>Pin Configuration and Functions .....</b>	<b>3</b>	<b>10</b>	<b>Power Supply Recommendations .....</b>	<b>39</b>
7	<b>Specifications .....</b>	<b>5</b>	<b>11</b>	<b>Layout .....</b>	<b>40</b>
7.1	Absolute Maximum Ratings .....	5	11.1	Layout Guidelines .....	40
7.2	ESD Ratings .....	5	11.2	Layout Example .....	40
7.3	Recommended Operating Conditions .....	5	<b>12</b>	<b>器件和文档支持 .....</b>	<b>41</b>
7.4	Thermal Information .....	5	12.1	接收文档更新通知 .....	41
7.5	Electrical Characteristics .....	6	12.2	社区资源 .....	41
7.6	Typical Characteristics .....	8	12.3	商标 .....	41
<b>8</b>	<b>Detailed Description .....</b>	<b>9</b>	12.4	静电放电警告 .....	41
8.1	Overview .....	9	12.5	Glossary .....	41
8.2	Functional Block Diagram .....	11	<b>13</b>	<b>机械、封装和可订购信息 .....</b>	<b>41</b>
8.3	Feature Description .....	12			

## 4 修订历史记录

注：之前版本的页码可能与当前版本有所不同。

Changes from Revision B (March 2015) to Revision C	Page
• 通篇将 WPC v1.1 更改为 WPC v1.2 .....	1
• <i>Receiver Coil</i> section, changed the literature number reference From: SLUUBSS To: SLUUB55 .....	30

Changes from Revision A (September 2014) to Revision B	Page
• 已更新 <i>特性</i> 和 <i>说明</i> 以包含 2S 支持 .....	1
• 把 2S 电池应用添加到了 <i>应用范围</i> .....	1
• Corrected $R_{ILIM}$ threshold for EPT 0x02 to match <i>Electrical Characteristics</i> .....	15
• Corrected section numbering for <i>TMEM</i> .....	29
• Added design example section for Standalone 10-V Power Supply for 2S Charging System .....	35

Changes from Original (September 2014) to Revision A	Page
• 将器件状态从“产品预览”更新为“生产” .....	1

## 5 Device Comparison Table

DEVICE	MODE	DESCRIPTION
bq51221	Dual (WPC v1.2, PMA)	Autonomous mode detection, I <sup>2</sup> C control, adjustable output voltage
bq51020	WPC v1.2	Stand-alone solution, adjustable output voltage, highest system efficiency
bq51025	WPC v1.2, Proprietary 10 W	I <sup>2</sup> C control, adjustable output voltage, 10-W maximum output power

## 6 Pin Configuration and Functions

YFP Package  
42-Pin DSBGA  
Top View

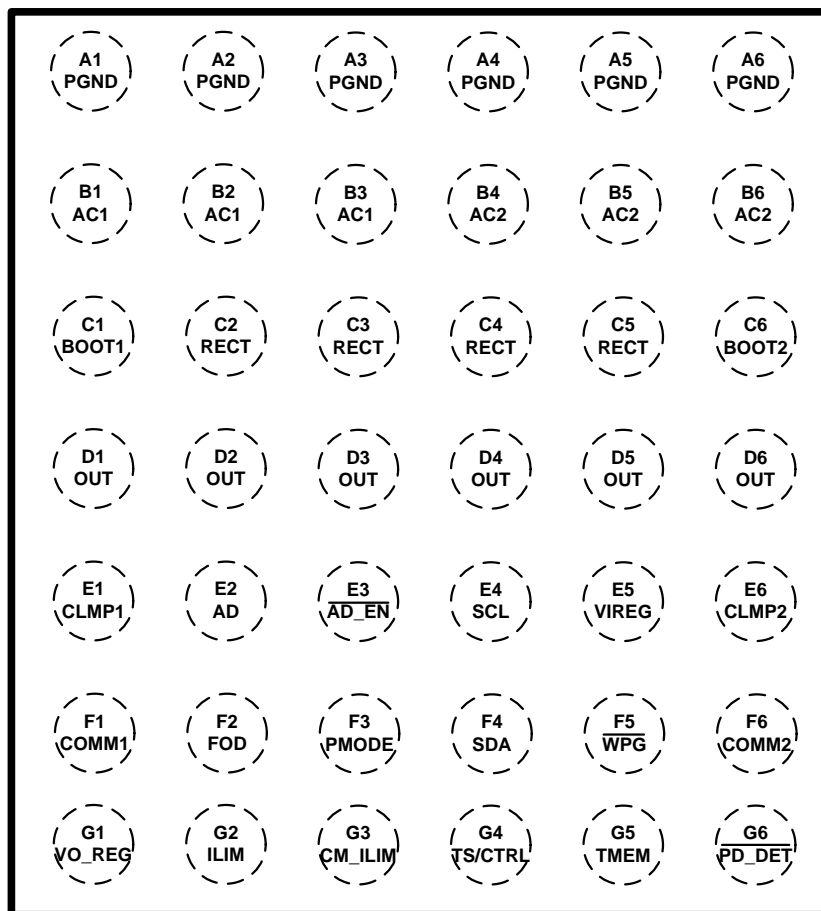

### Pin Functions

PIN		TYPE	DESCRIPTION
NAME	NO.		
AC1	B1	I	AC input power from receiver resonant tank
	B2		
	B3		
AC2	B4	I	
	B5		
	B6		
AD	E2	I	Adapter sense pin
$\overline{\text{AD-EN}}$	E3	O	Push-pull driver for dual PFET circuit that can pass AD input to the OUT pin; used for adapter MUX control
BOOT1	C1	O	Bootstrap capacitors for driving the high-side FETs of the synchronous rectifier
BOOT2	C6	O	
CLAMP1	E1	O	Open-drain FETs used to clamp the secondary voltage by providing low impedance across secondary
CLAMP2	E6	O	
COMM1	F1	O	Open-drain FETs used to communicate with primary by varying reflected impedance
COMM2	F6	O	
CM_ILIM	G3	I	Enables communication current limit when pulled low or left floating.
FOD	F2	I	Input that is used for scaling the received power message
ILIM	G2	I/O	Output current or overcurrent level programming pin
OUT	D1	O	Output pin, used to deliver power to the load
	D2		
	D3		
	D4		
	D5		
	D6		
$\overline{\text{PD\_DET}}$	G6	O	Open-drain output that allows user to sense when receiver is on transmitter
PGND	A1	—	Power and logic ground
	A2		
	A3		
	A4		
	A5		
	A6		
RECT	C2	O	Filter capacitor for the internal synchronous rectifier
	C3		
	C4		
	C5		
SCL	E4	I	SCL and SDA are used for I <sup>2</sup> C communication. Connect to ground if not needed.
SDA	F4	I/O	
PMODE	F3	O	Indicates receiver mode of operation: Low = Proprietary 10-W mode, High = Low-power mode. Gate drive output for external current limit switch. Connect 5-M $\Omega$ resistor to ground. Leave floating if unused.
TMEM	G5	O	TMEM allows the capacitor to be connected to GND so energy from transmitter ping can be stored to retain memory of state.
TS/CTRL	G4	I	Temperature sense. Can be pulled high to send end power transfer (EPT) – charge complete to TX. Can be pulled low to send EPT – over temperature
VO_REG	G1	I	Sets the regulation voltage for output. Default value is 0.5 V.
VIREG	E5	I	Rectifier voltage feedback
$\overline{\text{WPG}}$	F5	O	Open-drain output that allows user to sense when power is transferred to load

## 7 Specifications

### 7.1 Absolute Maximum Ratings

over operating free-air temperature (unless otherwise noted)<sup>(1) (2)</sup>

		MIN	MAX	UNIT
Input voltage	AC1, AC2	-0.8	20	V
	RECT, COMM1, COMM2, OUT, CLAMP1, CLAMP2, $\overline{\text{WPG}}$ , $\overline{\text{PD\_DET}}$	-0.3	20	
	AD, $\overline{\text{AD-EN}}$	-0.3	30	
	BOOT1, BOOT2	-0.3	20	
	SCL, SDA, PMODE, CM_ILIM, FOD, TS/CTRL, ILIM, TMEM, VIREG, VO_REG	-0.3	7	
Input current	AC1, AC2 (RMS)	2.5		A
Output current	OUT	2.5		A
Output sink current	$\overline{\text{WPG}}$ , $\overline{\text{PD\_DET}}$	15		mA
Output sink current	COMM1, COMM2	1		A
T <sub>J</sub>	Junction temperature	-40	150	°C
T <sub>stg</sub>	Storage temperature	-65	150	°C

(1) All voltages are with respect to the PGND pin, unless otherwise noted.

(2) Stresses beyond those listed under *Absolute Maximum Ratings* may cause permanent damage to the device. These are stress ratings only, and functional operation of the device at these or any other conditions beyond those indicated under *Recommended Operating Conditions* is not implied. Exposure to absolute-maximum-rated conditions for extended periods may affect device reliability.

### 7.2 ESD Ratings

		VALUE	UNIT
V <sub>(ESD)</sub>	Electrostatic discharge	Human body model (HBM) 100 pF, 1.5 kΩ <sup>(1)</sup>	±2000
		Charged device model (CDM) <sup>(2)</sup>	±500

(1) JEDEC document JEP155 states that 500-V HBM allows safe manufacturing with a standard ESD control process.

(2) JEDEC document JEP157 states that 250-V CDM allows safe manufacturing with a standard ESD control process.

### 7.3 Recommended Operating Conditions

over operating free-air temperature range (unless otherwise noted)

		MIN	MAX	UNIT
V <sub>RECT</sub>	RECT voltage	4	11	V
I <sub>OUT</sub>	Output current		2.0	A
I <sub>AD-EN</sub>	Sink current		1	mA
I <sub>COMM</sub>	COMMx sink current		500	mA
T <sub>J</sub>	Junction temperature	0	125	°C

### 7.4 Thermal Information

THERMAL METRIC <sup>(1)</sup>		bq51025	UNIT
		YFP (DSBGA)	
		42 PINS	
R <sub>θJA</sub>	Junction-to-ambient thermal resistance	49.7	°C/W
R <sub>θJC(top)</sub>	Junction-to-case (top) thermal resistance	0.2	°C/W
R <sub>θJB</sub>	Junction-to-board thermal resistance	6.1	°C/W
ψ <sub>JT</sub>	Junction-to-top characterization parameter	1.4	°C/W
ψ <sub>JB</sub>	Junction-to-board characterization parameter	6.0	°C/W

(1) For more information about traditional and new thermal metrics, see the [Semiconductor and IC Package Thermal Metrics](#) application report.

## 7.5 Electrical Characteristics

 over operating free-air temperature range (unless otherwise noted),  $I_{LOAD} = I_{OUT}$ 

PARAMETER		TEST CONDITIONS	MIN	TYP	MAX	UNIT
$V_{UVLO}$	Undervoltage lockout	$V_{RECT}$ : 0 to 3 V		2.8	2.9	V
$V_{HYS-UVLO}$	Hysteresis on UVLO	$V_{RECT}$ : 3 to 2 V		393		mV
$V_{RECT-OVP}$	Input overvoltage threshold	$V_{RECT}$ : 5 to 16 V	14.6	15.1	15.6	V
$V_{HYS-OVP}$	Hysteresis on OVP	$V_{RECT}$ : 16 to 5 V		1.5		V
$V_{RECT(REG)}$	Voltage at RECT pin set by communication with primary		$V_{OUT} + 0.120$		Lower of $V_{OUT} + 0.2$ or 11.0	V
$V_{RECT(TRACK)}$	$V_{RECT}$ regulation above $V_{OUT}$	$V_{ILIM} = 1.2$ V		140		mV
$I_{LOAD-HYS}$	$I_{LOAD}$ hysteresis for dynamic $V_{RECT}$ thresholds as a % of $I_{ILIM}$	$I_{LOAD}$ falling		4%		
$V_{RECT-DPM}$	Rectifier undervoltage protection, restricts $I_{OUT}$ at $V_{RECT-DPM}$		3	3.1	3.2	V
$V_{RECT-REV}$	Rectifier reverse voltage protection with a supply at the output	$V_{RECT-REV} = V_{OUT} - V_{RECT}$ , $V_{OUT} = 10$ V		8.8	9.2	V
<b>QUIESCENT CURRENT</b>						
$I_{OUT(standby)}$	Quiescent current at the output when wireless power is disabled	$V_{OUT} \leq 5$ V, $0^\circ\text{C} \leq T_J \leq 85^\circ\text{C}$		20	35	$\mu\text{A}$
<b>ILIM SHORT CIRCUIT</b>						
$R_{ILIM-SHORT}$	Highest value of $R_{ILIM}$ resistor considered a fault (short). Monitored for $I_{OUT} > 100$ mA	$R_{ILIM}$ : 200 to 50 $\Omega$ . $I_{OUT}$ latches off, cycle power to reset		215	230	$\Omega$
$t_{DGL-Short}$	Deglintch time transition from ILIM short to $I_{OUT}$ disable			1		ms
$I_{LIM\_SC}$	$I_{LIM-SHORT,OK}$ enables the ILIM short comparator when $I_{OUT}$ is greater than this value	$I_{LOAD}$ : 0 to 200 mA	110	125	140	mA
$I_{LIM-SHORT,OK}$ HYSTERESIS	Hysteresis for $I_{LIM-SHORT,OK}$ comparator	$I_{LOAD}$ : 200 to 0 mA		20		mA
$I_{OUT-CL}$	Maximum output current limit	Maximum $I_{LOAD}$ that can be delivered for 1 ms when ILIM is shorted		3.7		A
<b>OUTPUT</b>						
$V_{O\_REG}$	Feedback voltage set point	$I_{LOAD} = 2000$ mA, $V_{O\_REG}$ resistor divider ratio = 9:1	0.4968	0.5019	0.5077	V
		$I_{LOAD} = 1$ mA, $V_{O\_REG}$ resistor divider ratio = 9:1	0.4971	0.5017	0.5079	
		$I_{LOAD} = 1000$ mA, $V_{O\_REG}$ resistor divider ratio = 19:1	0.4977	0.5027	0.5091	
		$I_{LOAD} = 1$ mA, $V_{O\_REG}$ resistor divider ratio = 19:1	0.4978	0.5029	0.5098	
$K_{ILIM}$	Current programming factor for hardware short circuit protection	$R_{ILIM} = K_{ILIM} / I_{ILIM}$ , where $I_{ILIM}$ is the hardware current limit $I_{OUT} = 900$ mA		842		$\text{A}\Omega$
$I_{OUT\_RANGE}$	Current limit programming range				2300	mA
$I_{COMM}$	Output current limit during communication	$I_{OUT} \geq 400$ mA		$I_{OUT} - 50$		mA
		$100$ mA $\leq I_{OUT} < 400$ mA		$I_{OUT} + 50$		
		$I_{OUT} < 100$ mA		200		
$t_{HOLD-OFF}$	Hold off time for the communication current limit during startup			1		s

## Electrical Characteristics (continued)

over operating free-air temperature range (unless otherwise noted),  $I_{LOAD} = I_{OUT}$ 

PARAMETER		TEST CONDITIONS	MIN	TYP	MAX	UNIT
<b>TS/CTRL</b>						
$V_{TS-Bias}$	TS bias voltage (internal)	$I_{TS-Bias} < 100 \mu A$ and communication is active (periodically driven, see $t_{TS/CTRL-Meas}$ )		1.8		V
$V_{CTRL-HI}$	CTRL pin threshold for a high	$V_{TS/CTRL}$ : 50 to 150 mV	90	105	120	mV
$T_{TS/CTRL-Meas}$	Time period of TS/CTRL measurements, when TS is being driven	TS bias voltage is only driven when power packets are sent			1700	ms
$V_{TS-HOT}$	Voltage at TS pin when device shuts down			0.38		V
<b>THERMAL PROTECTION</b>						
$T_{J(OFF)}$	Thermal shutdown temperature			155		°C
$T_{J(OFF-HYS)}$	Thermal shutdown hysteresis			20		°C
<b>OUTPUT LOGIC LEVELS ON <math>\overline{WPG}</math></b>						
$V_{OL}$	Open-drain $\overline{WPG}$ pin	$I_{SINK} = 5 \text{ mA}$			550	mV
$I_{OFF,STAT}$	$\overline{WPG}$ leakage current when disabled	$V_{WPG} = 20 \text{ V}$			1	$\mu A$
<b>COMM PIN</b>						
$R_{DS-ON(COMM)}$	COMM1 and COMM2	$V_{RECT} = 2.6 \text{ V}$		1		$\Omega$
$f_{COMM}$	Signaling frequency on COMMx pin for WPC			2.00		Kbps
$I_{OFF,COMM}$	COMMx pin leakage current	$V_{COMM1} = 20 \text{ V}$ , $V_{COMM2} = 20 \text{ V}$			1	$\mu A$
<b>CLAMP PIN</b>						
$R_{DS-ON(CLAMP)}$	CLAMP1 and CLAMP2			0.5		$\Omega$
<b>ADAPTER ENABLE</b>						
$V_{AD-EN}$	$V_{AD}$ rising threshold voltage	$V_{AD} 0 \text{ V to } 5 \text{ V}$	3.5	3.6	3.8	V
$V_{AD-EN-HYS}$	$V_{AD-EN}$ hysteresis	$V_{AD} 5 \text{ V to } 0 \text{ V}$		450		mV
$I_{AD}$	Input leakage current	$V_{RECT} = 0 \text{ V}$ , $V_{AD} = 5 \text{ V}$			50	$\mu A$
$R_{AD-EN-OUT}$	Pullup resistance from $\overline{AD-EN}$ to OUT when adapter mode is disabled and $V_{OUT} > V_{AD}$	$V_{AD} = 0 \text{ V}$ , $V_{OUT} = 5 \text{ V}$		230	350	$\Omega$
$V_{AD-EN-ON}$	Voltage difference between $V_{AD}$ and $V_{AD-EN}$ when adapter mode is enabled	$V_{AD} = 5 \text{ V}$ , $0^\circ C \leq T_J \leq 85^\circ C$	4	4.5	5	V
		$V_{AD} = 9 \text{ V}$ , $0^\circ C \leq T_J \leq 85^\circ C$	3	6	7	V
<b>SYNCHRONOUS RECTIFIER</b>						
$I_{SYNC-EN}$	$I_{OUT}$ at which the synchronous rectifier enters half synchronous mode	$I_{OUT}$ : 200 to 0 mA		100		mA
$I_{SYNC-EN-HYST}$	Hysteresis for $I_{OUT,RECT-EN}$ (full-synchronous mode enabled)	$I_{OUT}$ : 0 to 200 mA		40		mA
$V_{HS-DIODE}$	High-side diode drop when the rectifier is in half synchronous mode	$I_{AC-VRECT} = 250 \text{ mA}$ , and $T_J = 25^\circ C$		0.7		V
<b>I<sup>2</sup>C</b>						
$V_{IL}$	Input low threshold level SDA	$V(PULLUP) = 1.8 \text{ V}$ , SDA			0.4	V
$V_{IH}$	Input high threshold level SDA	$V(PULLUP) = 1.8 \text{ V}$ , SDA	1.4			V
$V_{IL}$	Input low threshold level SCL	$V(PULLUP) = 1.8 \text{ V}$ , SCL			0.4	V
$V_{IH}$	Input high threshold level SCL	$V(PULLUP) = 1.8 \text{ V}$ , SCL	1.4			V
	I <sup>2</sup> C speed	Typical		100		kHz

## 7.6 Typical Characteristics

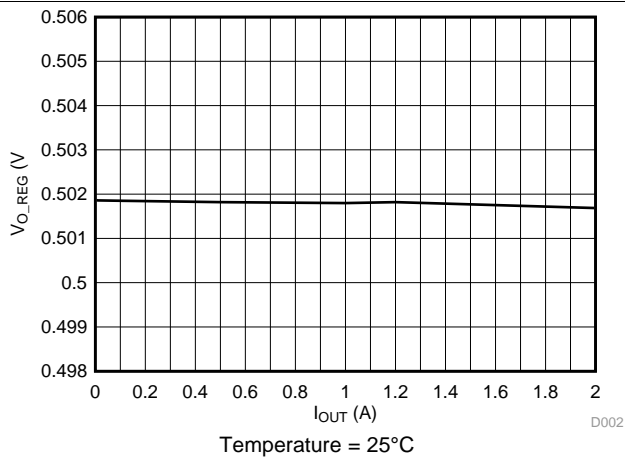

Figure 1. Output Regulation as a Function of Load

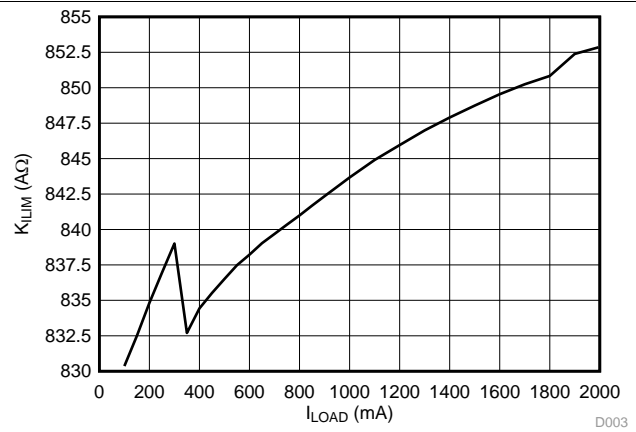

Figure 2. KILIM as a Function of Load Current

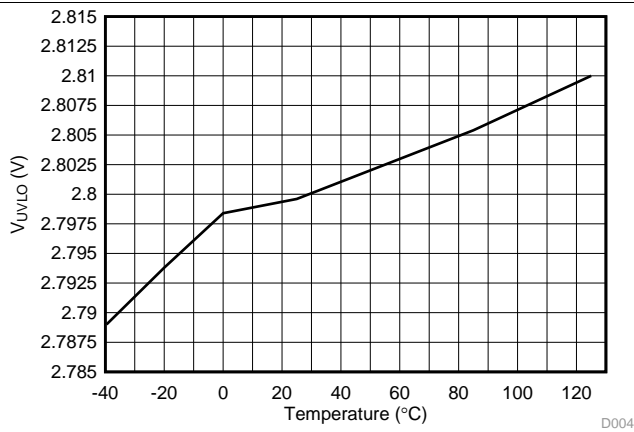

Figure 3. UVLO as a Function of Junction Temperature

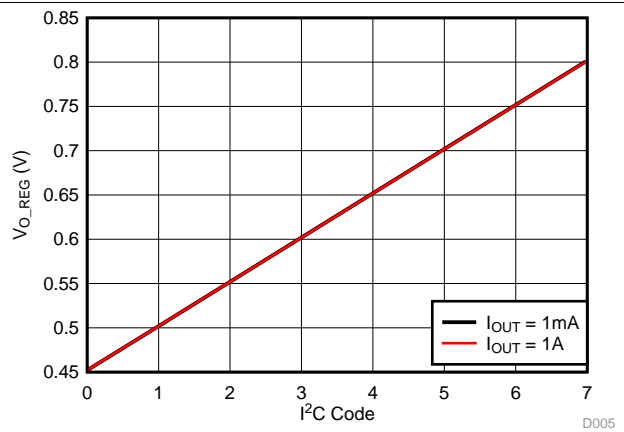

Figure 4.  $V_{O\_REG}$  by Different I<sup>2</sup>C Codes, Resistor Divider Ratio = 9:1

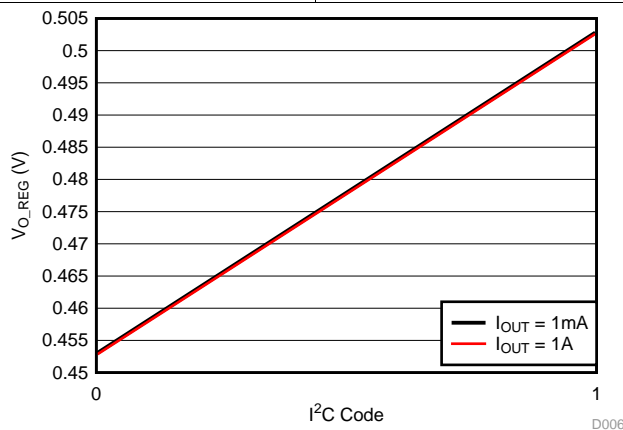

Figure 5.  $V_{O\_REG}$  by Different I<sup>2</sup>C Codes, Resistor Divider Ratio = 19:1



## 8 Detailed Description

### 8.1 Overview

WPC-based wireless power systems consist of a charging pad (primary, transmitter) and the secondary-side equipment (receiver). The coils in the charging pad and secondary equipment magnetically couple to each other when the receiver is placed on the transmitter. Power is transferred from the primary to the secondary by transformer action between the coils. The receiver can achieve control over the amount of power transferred by getting the transmitter to change the field strength by changing the frequency, duty cycle, or voltage rail energizing the primary coil.

The receiver equipment communicates with the primary by modulating the load seen by the primary. This load modulation results in a change in the primary coil current or primary coil voltage, or both, which is measured and demodulated by the transmitter.

In WPC, the system communication is digital (packets that are transferred from the secondary to the primary). Differential biphas encoding is used for the packets. The bit rate is 2 kb/s. Various types of communication packets are defined. These include identification and authentication packets, error packets, control packets, power usage packets, and end power transfer packets, among others.

The bq51025 incorporates a two-way proprietary authentication with the bq500215 primary controller that allows optimal power transfer and system performance up to 10-W output power while still complying with WPC v1.2 specifications.

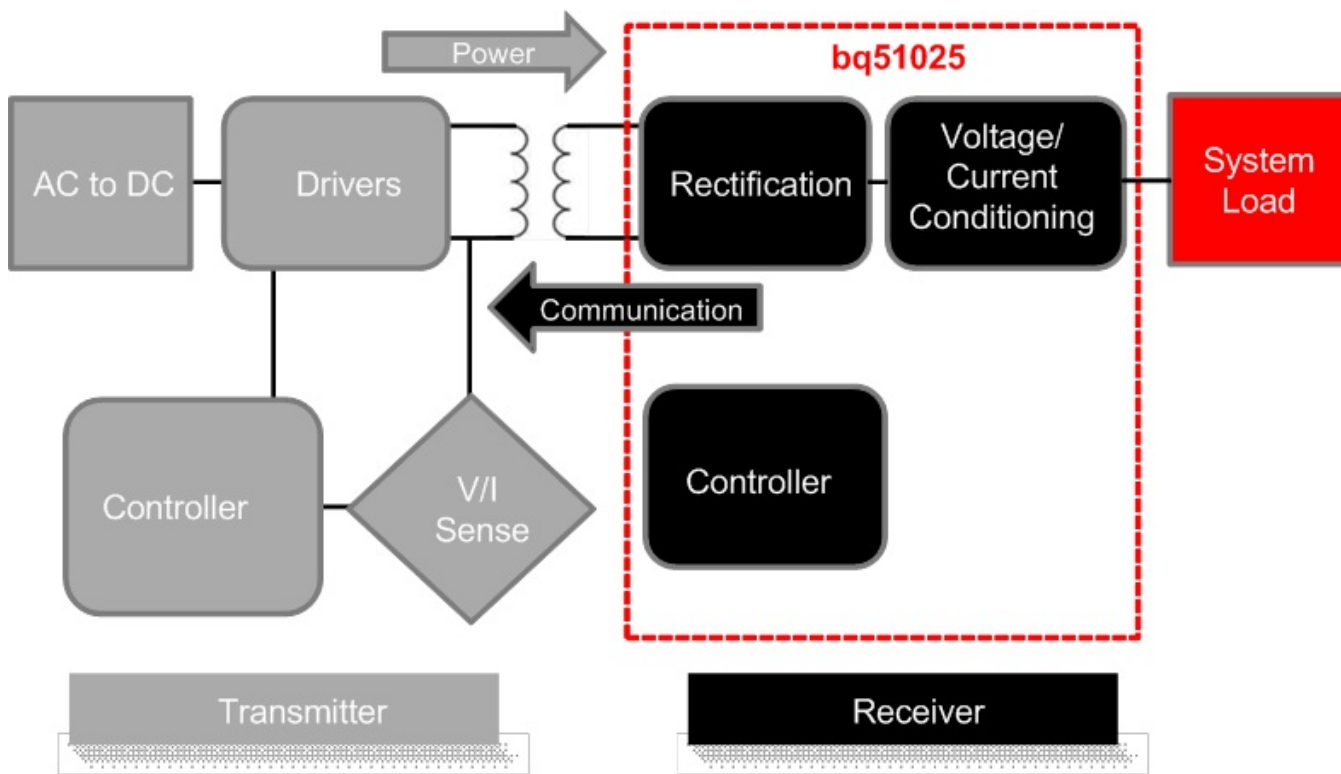

Figure 6. Wireless Power System Indicating the Functional Integration of the bq51025

The bq51025 device integrates fully-compliant WPC v1.2 communication protocol to streamline the wireless power receiver designs (no extra software development required). Other unique algorithms such as *Dynamic Rectifier Control* are integrated to provide best-in-class system efficiency while keeping the smallest solution size of the industry.

## Overview (continued)

As a WPC system, when the receiver (shown in [Figure 6](#)) is placed on the charging pad, the secondary coil couples to the magnetic flux generated by the coil in the transmitter, which consequently induces a voltage in the secondary coil. The internal synchronous rectifier feeds this voltage to the RECT pin, which in turn feeds the LDO which feeds the output.

The bq51025 device identifies and authenticates itself to the primary using the COMMx pins, switching on and off the COMM FETs, and hence, switching in and out COMM capacitors. If the authentication is successful, the primary remains powered-up. Using a proprietary authentication protocol, the bq51025 determines if the 10-W bq500215 primary controller is powering the device, in which case the bq51025 device allows operation up to 10-W. If the bq51025 determines that a standard WPC-compliant transmitter is powering it, it allows operation up to 5-W. The bq51025 device measures the voltage at the RECT pin, calculates the difference between the actual voltage and the desired voltage  $V_{RECT(REG)}$  and sends back error packets to the transmitter. This process goes on until the input voltage settles at  $V_{RECT(REG) MAX}$ . During a load change, the dynamic rectifier algorithm sets the target voltage between  $V_{RECT(REG) MAX}$  and  $V_{RECT(REG) MIN}$ , as shown in [Table 1](#). This algorithm enhances the transient response of the power supply.

After the voltage at the RECT pin is at the desired value, the pass FET is enabled. The voltage control loop ensures that the output voltage is maintained at  $V_{OUT(REG)}$ , powering the downstream charger. The bq51025 device meanwhile continues to monitor the input voltage, and keeps sending control error packets (CEP) to the primary, on average, every 250 ms. If a large transient occurs, the feedback to the primary speeds up to 32-ms communication periods to converge on an operating point in less time.

## 8.2 Functional Block Diagram

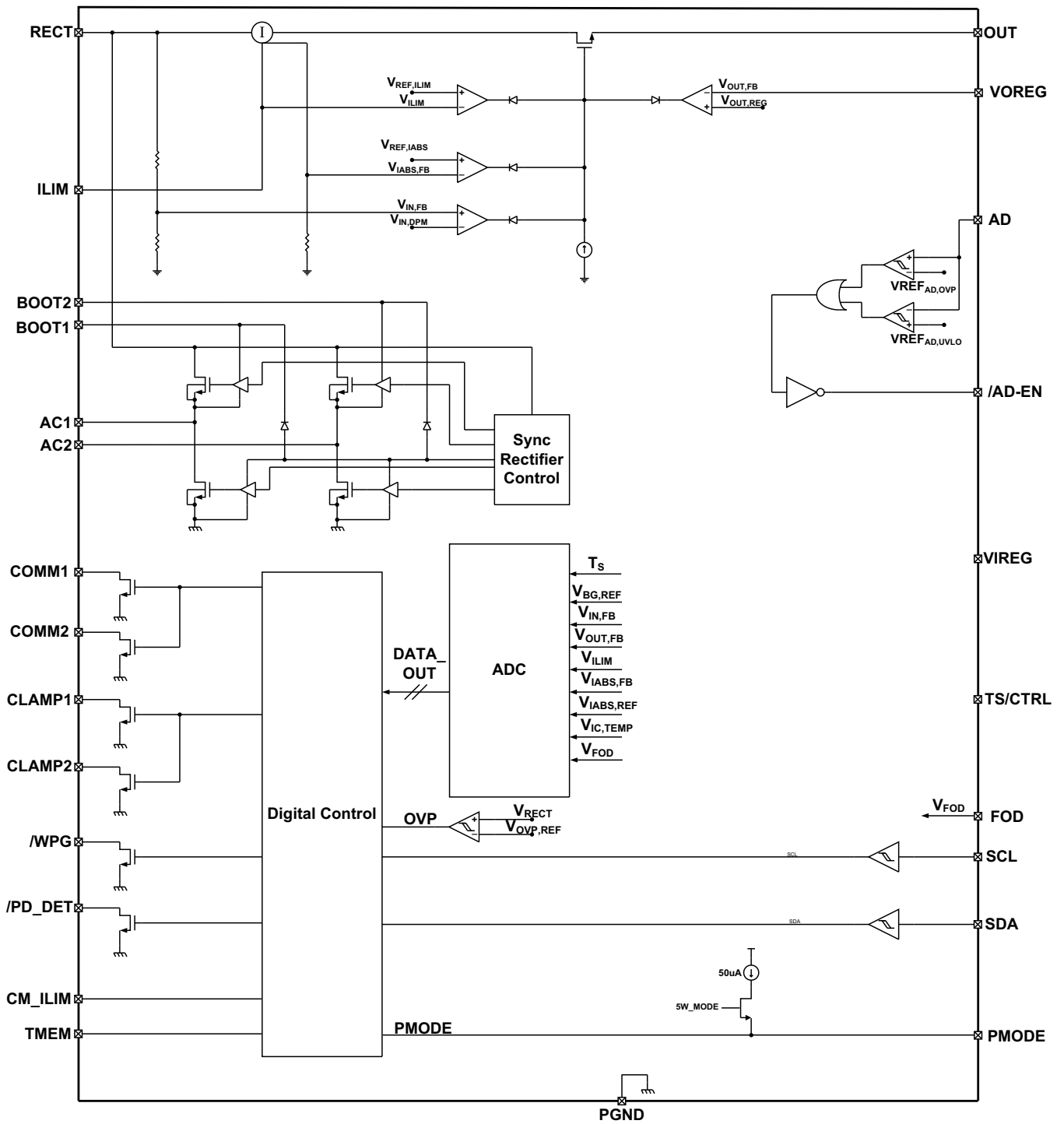

Copyright © 2016, Texas Instruments Incorporated

## 8.3 Feature Description

### 8.3.1 Dynamic Rectifier Control

The *Dynamic Rectifier Control* algorithm offers the end-system designer optimal transient response for a given maximum output current setting. This is achieved by providing enough voltage headroom across the internal regulator (LDO) at light loads in order to maintain regulation during a load transient. The WPC system has a relatively slow global feedback loop where it can take up to 150 ms to converge on a new rectifier voltage target. Therefore, a transient response depends on the loosely-coupled transformer's output-impedance profile. The *Dynamic Rectifier Control* allows for a 1.5-V change in rectified voltage before the transient response is observed at the output of the internal regulator (output of the bq51025 device). A 1-A application allows up to a 2-Ω output impedance. [Figure 13](#) shows the *Dynamic Rectifier Control* behavior during active power transfer.

### 8.3.2 Dynamic Power Scaling

The *Dynamic Power Scaling* feature allows for the loss characteristics of the bq51025 device to be scaled based on the maximum expected output power in the end application. This effectively optimizes the efficiency for each application. This feature is achieved by scaling the loss of the internal LDO based on a percentage of the maximum output current. Note that the maximum output current is set by the  $K_{ILIM}$  term and the  $R_{ILIM}$  resistance (where  $R_{ILIM} = K_{ILIM} / I_{ILIM}$ ). The flow diagram in [Figure 13](#) shows how the rectifier is dynamically controlled (*Dynamic Rectifier Control*) based on the voltage level at the ILIM pin ( $V_{ILIM}$ ). This voltage represents a fixed percentage of the  $I_{ILIM}$  setting. [Table 1](#) summarizes how the rectifier behavior is dynamically adjusted based on two different  $R_{ILIM}$  settings. [Table 1](#) is shown for  $I_{MAX}$ , which is the maximum operating output current and is typically lower than  $I_{ILIM}$  (about 20% lower). See [RILIM Calculations](#) for more details on how to set  $I_{ILIM}$ .

**Table 1. Dynamic Rectifier Regulation<sup>(1)</sup>**

Output Current Percentage (Low-Power Mode)	Output Current Percentage (Proprietary Mode)	Low Power (5-W) Mode $R_{ILIM} = 700 \Omega$ $I_{ILIM} = 0.6 \text{ A}$ ( $I_{MAX} = 0.5 \text{ A}$ )	Low Power (5-W) Mode $R_{ILIM} = 700 \Omega$ $I_{ILIM} = 1.2 \text{ A}$ ( $I_{MAX} = 1 \text{ A}$ )	Proprietary 10-W Mode $R_{ILIM} = 495 \Omega$ $I_{ILIM} = 1.7 \text{ A}$ ( $I_{MAX} = 1.4 \text{ A}$ )	$V_{RECT}^{(2)}$
0 to 10%	0 to 5%	0 to 0.05 A	0 to 0.05 A	0 to 0.070 A	$V_{OUT} + 2.0$
10 to 20%	5 to 10%	0.05 to 0.1 A	0.05 to 0.1 A	0.070 to 0.14 A	$V_{OUT} + 1.6$
20 to 40%	10 to 20%	0.1 to 0.2 A	0.1 to 0.2 A	0.14 to 0.28 A	$V_{OUT} + 0.6$
>40%	>20%	>0.2 A	>0.2 A	>0.28 A	$V_{OUT} + 0.12$

(1)  $R_{OS} = \text{Open}$ . The relation between  $V_{ILIM}$  and  $I_{ILIM}$  has some dependency on the  $R_{OS}$  value.

(2)  $V_{RECT}$  is regulated to a maximum of 11 V.

[Table 1](#) shows the shift in the *Dynamic Rectifier Control* behavior based on the two different  $R_{ILIM}$  settings. With the rectifier voltage ( $V_{RECT}$ ) as the input to the internal LDO, this adjustment in the *Dynamic Rectifier Control* thresholds dynamically adjusts the power dissipation across the LDO where,

$$P_{DIS} = (V_{RECT} - V_{OUT}) \cdot I_{OUT} \quad (1)$$

[Figure 22](#) shows how the *Dynamic Power Scaling* feature reduces the  $V_{RECT}$  with increased load, allowing the post-regulation LDO to have maximum headroom at low load conditions for better load transient performance and minimal power dissipation at high loads. Note that this feature balances efficiency with optimal system transient response.

### 8.3.3 VO\_REG Calculations

The bq51025 device allows the designer to set the output voltage by setting a feedback resistor divider network from the OUT pin to the VO\_REG pin, as seen in [Figure 7](#). Select the resistor divider network so that the voltage at the VO\_REG pin is 0.5 V (default setting) at the desired output voltage. The target VO\_REG voltage can be changed through I<sup>2</sup>C by changing [Table 4](#)

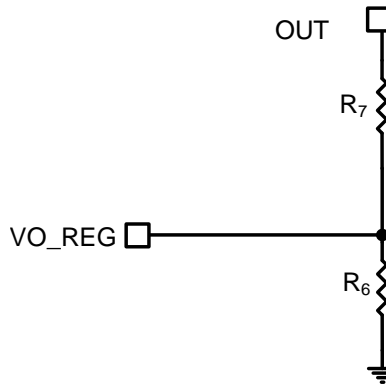

Figure 7. VO\_REG Network

Choose the desired output voltage  $V_{OUT}$  and  $R_6$ :

$$K_{VO} = \frac{0.5 \text{ V}}{V_{OUT}} \quad (2)$$

$$R_6 = \frac{K_{VO} \times R_7}{1 - K_{VO}} \quad (3)$$

### 8.3.4 RILIM Calculations

The bq51025 device includes a means of providing hardware overcurrent protection ( $I_{ILIM}$ ) through an analog current regulation loop. The hardware current limit provides an extra level of safety by clamping the maximum allowable output current (for example, current compliance). The  $R_{ILIM}$  resistor size also sets the thresholds for the dynamic rectifier levels providing efficiency tuning per each application's maximum system current. The calculation for the total  $R_{ILIM}$  resistance is as follows:

$$R_{ILIM} = \frac{K_{ILIM}}{I_{ILIM}} \quad (4)$$

$$R_1 = R_{ILIM} - R_{FOD} \quad (5)$$

The  $R_{ILIM}$  allows for the ILIM pin to reach 1.2 V when operating in proprietary mode (up to 10-W output power) when the output current is equal to  $I_{ILIM}$ . When the receiver operates in standard WPC low-power mode, the ILIM pin voltage threshold is changed from 1.2 to 0.6 V, setting the low-power mode current limit to half of that at the proprietary mode setting.

In the case where having the current limit change by a factor of two between modes is not desired, the two current limit levels may be independently controlled in two ways:

- By programming the IO\_REG level through I<sup>2</sup>C
- By changing the effective  $R_{ILIM}$  value for each mode by using an external switch controlled by the PMODE pin

To adjust the current limit for each mode through I<sup>2</sup>C,  $R_{ILIM}$  is chosen using Equation 4 where  $I_{ILIM}$  is the current limit for proprietary mode (that is, higher current setting). The host should first set the desired current limit value for low-power mode as a percentage of  $I_{ILIM}$  through the IO\_REG bits and then disable the 2X current scaling by setting the I2C\_ILIM bit in Table 5 and Table 6 respectively to enable programmability. By default, IO\_REG is set to the highest current setting allowed by  $R_{ILIM}$  (that is, 100% of  $I_{ILIM}$ ).

If I<sup>2</sup>C control is not available, the current limit for low power and proprietary modes can be set independently by shorting a portion of the  $R_1$  resistance using an external switch as shown in Figure 8.  $R_{ILIM}$  is calculated using Equation 4, where  $I_{ILIM}$  is the desired current limit for proprietary mode. The resistance to set the current limit in low-power mode,  $R_{ILIM\_LP}$  is calculated by Equation 6.

$$R_{ILIM\_LP} = \frac{K_{ILIM}}{2 \times I_{ILIM\_LP}} \quad (6)$$

where  $I_{ILIM\_LP}$  is the desired current limit value in low-power mode

The value for  $R_{1\_A}$  is given by  $R_{ILIM\_LP} - R_{FOD}$ . The value of  $R_{1\_B}$  is then  $R_{ILIM} - R_{1\_A} - R_{FOD}$ . Note that with this method  $I_{ILIM}$  must be less than  $2 \times I_{ILIM\_LP}$

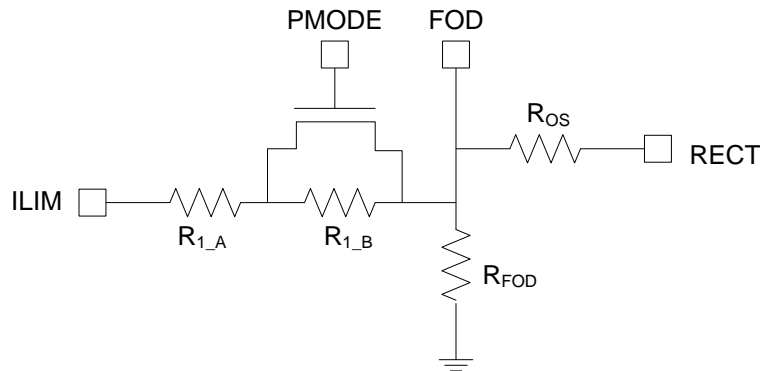

**Figure 8. Current Limit Setting for bq51025 Using External Switch**

When choosing  $I_{ILIM}$ , consider the following two possible operating conditions:

- If the user's application requires an output current equal to or greater than the external  $I_{ILIM}$  that the circuit is designed for (input current limit on the charger where the receiver device is tied higher than the external  $I_{ILIM}$ ), ensure that the downstream charger is capable of regulating the voltage of the input into which the receiver device output is tied to by lowering the amount of current being drawn. This ensures that the receiver output does not drop to zero. Such behavior is referred to as VIN DPM in TI chargers. Unless such behavior is enabled on the charger, the charger pulls the output of the receiver device to ground when the receiver device enters current regulation.
- If the user's applications are designed to extract less than the  $I_{ILIM}$ , typical designs should leave a design margin of at least 10%, so that the voltage at ILIM pin reaches 1.2 V when 10% more than maximum current is drawn from the output. Such a design would have input current limit on the charger lower than the external ILIM of the receiver device.

However, in both cases, the charger must be capable of regulating the current drawn from the device to allow the output voltage to stay at a reasonable value. This same behavior is also necessary during the WPC communication. The following calculations show how such a design is achieved:

$$R_{ILIM} = \frac{K_{ILIM}}{1.1 \times I_{ILIM}} \quad (7)$$

$$R_1 = R_{ILIM} - R_{FOD}$$

$$\text{where } I_{LIM} \text{ is the hardware current limit} \quad (8)$$

When referring to the application diagram shown in [Typical Applications](#),  $R_{ILIM}$  is the sum of the  $R_1$  and  $R_{FOD}$  resistance (that is, the total resistance from the ILIM pin to GND).  $R_{FOD}$  is chosen according to the application. To obtain the tool for calculating  $R_{FOD}$ , contact your TI representative. Use  $R_{FOD}$  to allow the receiver implementation to comply with WPC v1.2 requirements related to received power accuracy.

### 8.3.5 Adapter Enable Functionality

The bq51025 device can also help manage the multiplexing of adapter power to the output and can shut off the TX when the adapter is plugged in and is above the  $V_{AD-EN}$ . After the adapter is plugged in and the output turns off, the RX device sends an EPT to the TX. In this case, the  $\overline{AD\_EN}$  pins are then pulled to approximately 4 V below AD, which allows the device to turn on the back-to-back PMOS connected between AD and OUT (see [Figure 32](#)).

Both the AD and  $\overline{AD-EN}$  pins are rated at 30 V, while the OUT pin is rated at 20 V. Note that it is required to connect a back-to-back PMOS between AD and OUT so that voltage is blocked in both directions. Also, when AD mode is enabled, no load can be pulled from the RECT pin because this could cause an internal device overvoltage in the bq51025 device.

### 8.3.6 Turning Off the Transmitter

The WPC v1.2 specification allows the receiver to turn off the transmitter and put the system in a low-power standby mode. There are two different ways to accomplish this with the bq51025 device. The EPT charge complete (WPC) can be sent to the TX by pulling the TS pin high (above 1.4 V). The bq51025 device will then sense this and send the appropriate signal to the TX, thus putting the TX in a low-power standby mode.

#### 8.3.6.1 WPC v1.2 EPT

The WPC allows for a special command to terminate power transfer from the TX-terminated EPT packet. The WPC v1.2 specifies the following reasons and their corresponding data field value in [Table 2](#).

**Table 2. EPT Codes in WPC**

Reason	Value	Condition <sup>(1)</sup>
Unknown	0x00	AD > 3.6 V
Charge complete	0x01	TS/CTRL > 1.4 V
Internal fault	0x02	$T_J > 150^{\circ}\text{C}$ or $R_{ILIM} < 215 \Omega$
Over temperature	0x03	$TS < V_{HOT}$ , or $TS/CTRL < 100 \text{ mV}$ <sup>(2)</sup>
Over voltage	0x04	$V_{RECT}$ voltage does not converge and stays higher than target
Battery failure	0x06	Not sent
Reconfigure	0x07	Not sent
No response	0x08	Not sent

(1) The *Condition* column corresponds to the case where the bq51025 device sends the WPC EPT command.

(2) The  $TS < V_{TS-HOT}$  condition refers to using an external thermistor for temperature control. The  $TS/CTRL < 100\text{-mV}$  condition refers to driving the TS/CTRL pin from external GPIO.

### 8.3.7 Communication Current Limit

Communication current limit is a feature that allows for error-free communication to happen between the RX and TX in the WPC mode. This is done by decoupling the coil from the load transients by limiting the output current during communication with the TX. The communication current limit is set according to [Table 3](#). The communication current limit can be enabled by pulling CM\_ILIM pin low or disabled by pulling the CM\_ILIM pin high (>1.4 V). An internal pulldown enables communication current limit when the CM\_ILIM pin is left floating.

**Table 3. Communication Current Limit**

$I_{OUT}$	Communication Current Limit
$0 \text{ mA} < I_{OUT} < 100 \text{ mA}$	None
$100 \text{ mA} < I_{OUT} < 400 \text{ mA}$	$I_{OUT} + 50 \text{ mA}$
$400 \text{ mA} < I_{OUT} < \text{Max current}$	$I_{OUT} - 50 \text{ mA}$

When the communication current limit is enabled, the amount of current that the load can draw is limited. If the charger in the system does not have a VIN-DPM feature, the output of the receiver collapses if communication current limit is enabled. Please note that power dissipation within the device will increase during current limiting, lowering overall system efficiency. To disable communication current limit, pull CM\_ILIM pin high.

### 8.3.8 $\overline{\text{PD\_DET}}$ and TMEM

$\overline{\text{PD\_DET}}$  is an open-drain pin that goes low based on the voltage of the TMEM pin. When the voltage of TMEM is higher than 1.6 V,  $\overline{\text{PD\_DET}}$  is low. The voltage on the TMEM pin depends on capturing the energy from the digital ping from the transmitter and storing it on the  $C_5$  capacitor in [Figure 9](#). After the receiver sends an EPT (charge complete), the transmitter shuts down and goes into a low-power mode. However, it continues to check if the receiver would like to renegotiate a power transfer by periodically performing the digital ping. The energy from the digital ping can be stored on the TMEM pin until the next digital ping refreshes the capacitor. The designer can choose a bleedoff resistor,  $R_{MEM}$ , in parallel with  $C_5$  that sets the time constant so that the TMEM pin will fall below 1.6 V once the next ping timer expires. The duration between digital pings is indeterminate and depends on each transmitter manufacturer.

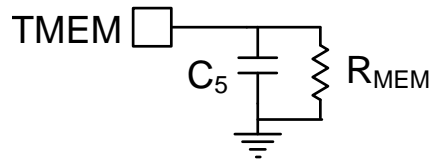
**Figure 9. TMEM Configuration**

Set capacitor on  $C_5 = \text{TMEM}$  to 2.2  $\mu\text{F}$ . Resistor  $R_{\text{MEM}}$  across  $C_5$  can be set by understanding the duration between digital pings ( $t_{\text{ping}}$ ). Set the resistor such that:

$$R_{\text{MEM}} = \frac{t_{\text{ping}}}{4 \times C_5} \quad (9)$$

$\overline{\text{PD\_DET}}$  typically requires a pullup resistor to an external source. A higher current through the  $\overline{\text{PD\_DET}}$  pin may affect the output regulation of the device. To improve regulation, TI recommends pullup resistor values in the range of 15 to 100 k $\Omega$ .

### 8.3.9 TS/CTRL

The bq51025 device includes a ratiometric external temperature sense function. The temperature sense function has a low ratiometric threshold which represents a hot condition. TI recommends an external temperature sensor to provide safe operating conditions for the receiver product. This pin is best used for monitoring the surface that can be exposed to the end user (for example, place the negative temperature coefficient (NTC) resistor closest to the user touch point on the back cover). A resistor in series or parallel can be inserted to adjust the NTC to match the trip point of the device. The implementation in [Figure 10](#) shows the series-parallel resistor implementation for setting the threshold at which  $V_{\text{TS-HOT}}$  is reached. When the  $V_{\text{TS-HOT}}$  threshold is reached, the device will send an EPT – overtemperature signal for a WPC transmitter.

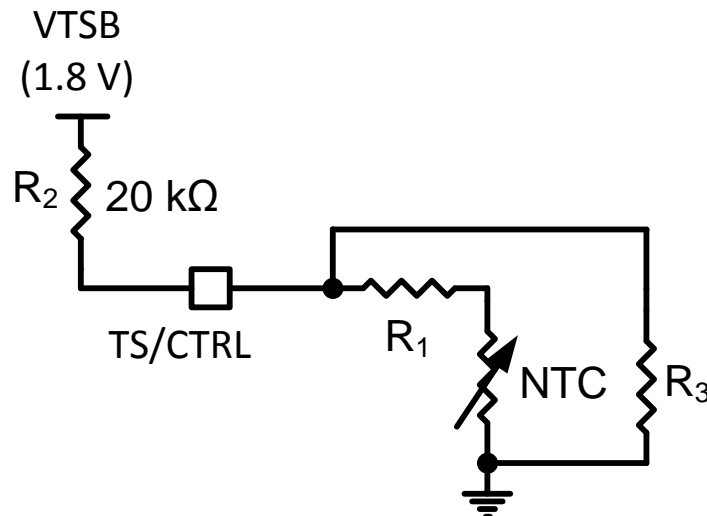
**Figure 10. NTC Resistor Setup**

[Figure 10](#) shows a parallel resistor setup that can be used to adjust the trip point of  $V_{\text{TS-HOT}}$ . After the NTC is chosen and  $R_{\text{NTCHOT}}$  at  $V_{\text{TS-HOT}}$  is determined from the data sheet of the NTC, use [Equation 10](#) to calculate  $R_1$  and  $R_3$ . In many cases, depending on the NTC resistor,  $R_1$  or  $R_3$  can be omitted. To omit  $R_1$ , set  $R_1$  to 0, and to omit  $R_3$ , set  $R_3$  to 10 M $\Omega$  in the calculation.

$$V_{\text{TS-HOT}} = 1.8 \text{ V} \times \frac{\frac{(R_{\text{NTCHOT}} + R_1) \times R_3}{(R_{\text{NTCHOT}} + R_1) + R_3}}{\left(\frac{(R_{\text{NTCHOT}} + R_1) \times R_3}{(R_{\text{NTCHOT}} + R_1) + R_3}\right) + R_2} \quad (10)$$



### 8.3.10 PMODE Pin

Connect a 5-MΩ resistor to ground in order to use PMODE to indicate the receiver mode of operation. PMODE is high when in low-power mode and low in proprietary mode. This pin may be used to control the gate of an NMOS switch to change the  $R_{ILIM}$ , and hence, the current limit based on the maximum power allowed by the transmitter (10 W for bq500215, 5 W or less otherwise). This pin may be left floating if not used. and show the PMODE behavior during startup.

### 8.3.11 I<sup>2</sup>C Communication

The bq51025 device allows for I<sup>2</sup>C communication with the internal CPU. The I<sup>2</sup>C address for the device is 0x6C. In case the I<sup>2</sup>C is not used, ground SCL and SDA. See [Register Maps](#) for more information.

### 8.3.12 Input Overvoltage

If the input voltage suddenly increases in potential for some condition (for example, a change in position of the equipment on the charging pad), the voltage-control loop inside the bq51025 device becomes active, and prevents the output from going beyond  $V_{OUT(REG)}$ . The receiver then starts sending back error packets every 32 ms until the input voltage comes back to an acceptable level, and then maintains the error communication every 250 ms.

If the input voltage increases in potential beyond  $V_{RECT\_OVP}$ , the device switches off the LDO and informs the primary to terminate power. In addition, a proprietary voltage protection circuit is activated by means of  $C_{CLAMP1}$  and  $C_{CLAMP2}$  that protects the device from voltages beyond the maximum rating of the device.

### 8.3.13 Alignment Aid Using Frequency Information

The bq51025 device provides the host through I<sup>2</sup>C with power signal frequency information that would enable it to determine the optimal alignment position on the charging surface of a frequency-controlled transmitter. For these WPC transmitters, the power signal frequency increases as the coupling between the primary and secondary coils increases. By finding the position in the charging pad that has the highest frequency, the host can determine that the best possible alignment with the transmitter coil has been achieved.

The bq51025 continuously stores a measurement of the power signal frequency in I<sup>2</sup>C register 0xFB to provide the host the information it needs to determine optimal placement. The power signal frequency is given by:

$$f_{AC} = 7259 \times \text{Code}^{-0.982}$$

where  $f_{AC}$  is the power signal frequency measured at the AC pins in kHz and code is the decimal value in the 0xFB register (11)

Figure 11 shows the expected register values across the frequency range.

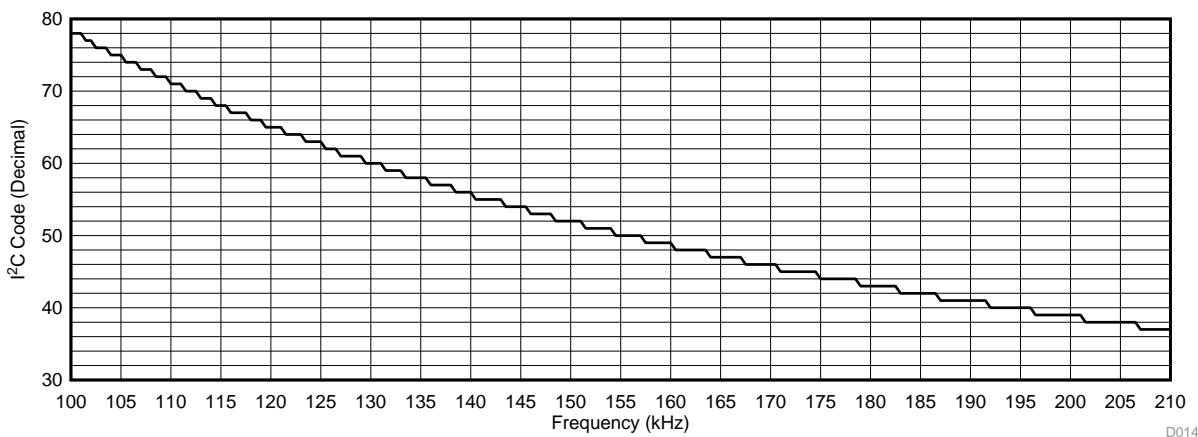

Figure 11. I<sup>2</sup>C Code vs Power Signal Frequency

## 8.4 Device Functional Modes

At startup operation, the bq51025 device must comply with proper handshaking to be granted a power contract from the WPC transmitter. The transmitter initiates the handshake by providing an extended digital ping after analog ping detects an object on the transmitter surface. If a receiver is present on the transmitter surface, the receiver then provides the signal strength, configuration, and identification packets to the transmitter (see volume 1 of the WPC specification for details on each packet). These are the first three packets sent to the transmitter. The only exception is if there is a true shutdown condition on the AD or TS/CTRL pins where the receiver shuts down the transmitter immediately. See [Table 2](#) for details. After the transmitter has successfully received the signal strength, configuration, and identification packets, the receiver is granted a power contract and is then allowed to control the operating point of the power transfer. With the use of the bq51025 device *Dynamic Rectifier Control* algorithm, the receiver informs the transmitter to adjust the rectifier voltage to approximately 8 V prior to enabling the output supply. For startup flow diagram details, see [Figure 12](#).

To operate in 10-W mode, the bq51025 device performs a proprietary handshaking procedure with the transmitter. If the transmitter (bq500215) responds to the bq51025 handshake, a 10-W power contract is granted and the bq51025 operates in 10-W mode, setting the proper output current limit and control. If there is no response from the transmitter, the bq51025 device defaults to 5-W mode operation.

Device Functional Modes (continued)

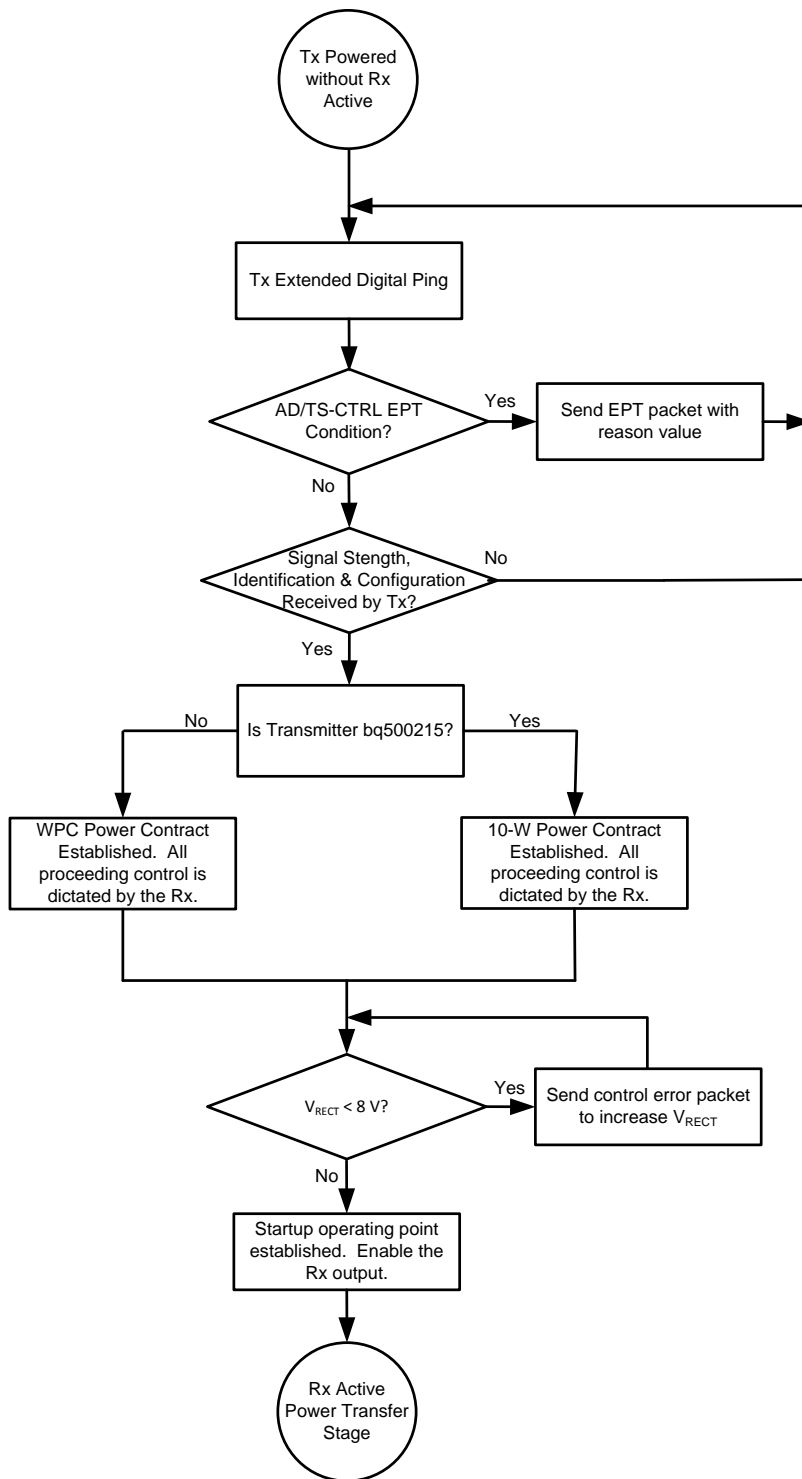
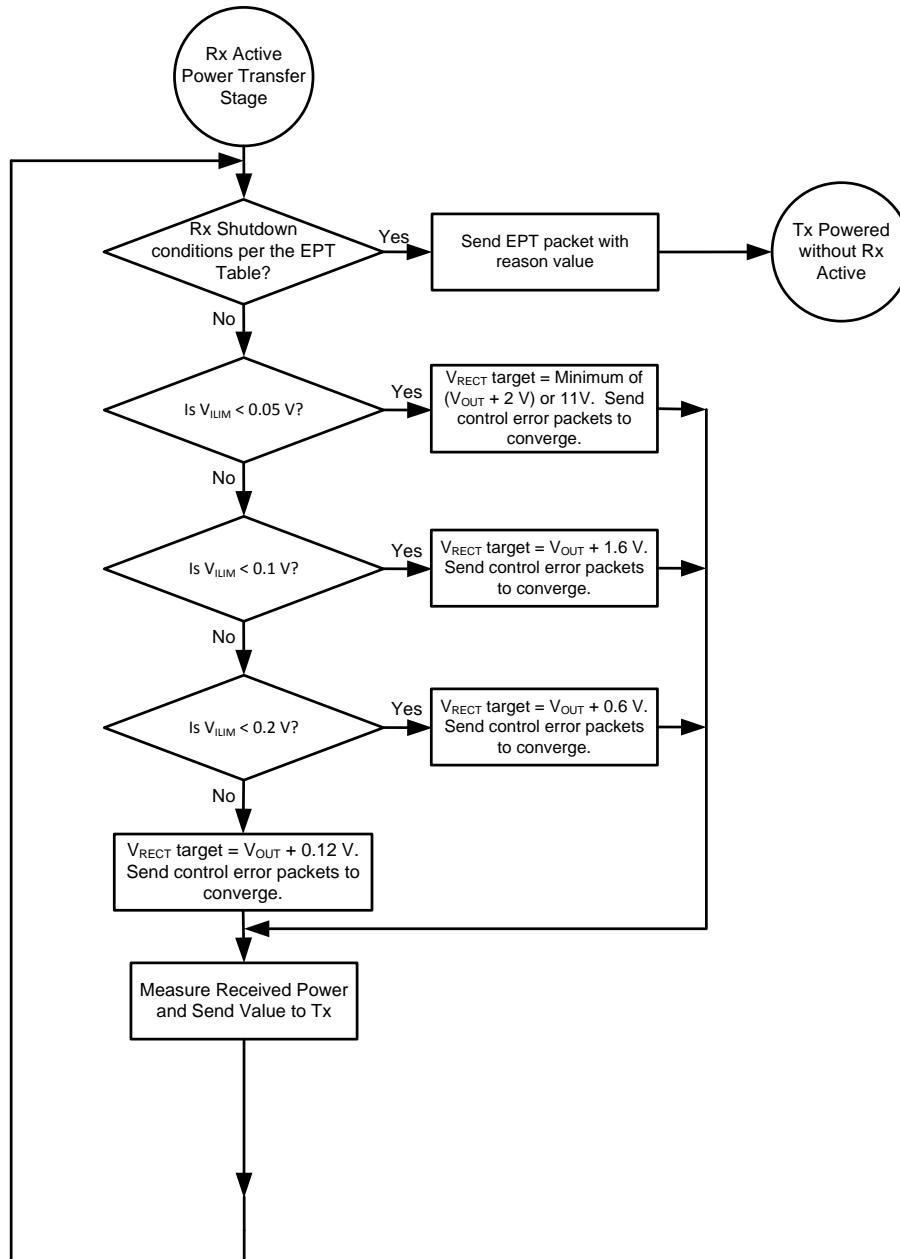

Figure 12. Wireless Power Startup Flow Diagram on WPC TX

**Device Functional Modes (continued)**

After the startup procedure is established, the receiver enters the active-power transfer stage (considered the main loop of operation). The *Dynamic Rectifier Control* algorithm determines the rectifier voltage target based on a percentage of the maximum output current level setting (set by  $K_{ILIM}$  and  $R_{ILIM}$ ). The receiver sends control error packets to converge on these targets. As the output current changes, the rectifier voltage target dynamically changes. As a note, the feedback loop of the WPC system is relatively slow, it can take up to 150 ms to converge on a new rectifier voltage target. It should be understood that the instantaneous transient response of the system is open loop and dependent on the receiver coil output impedance at that operating point. The main loop also determines if any conditions in [Table 2](#) are true in order to discontinue power transfer. [Figure 13](#) shows the active-power transfer loop.

**Figure 13. Active Power Transfer Flow Diagram on WPC TX**

## 8.5 Register Maps

Locations 0x01 and 0x02 can be written at any time. Locations 0xE0 to 0xFF are only functional when  $V_{RECT} > V_{UVLO}$ . When  $V_{RECT}$  goes below  $V_{UVLO}$ , locations 0xE0 to 0xFF are reset.

### 8.5.1 Wireless Power Supply Current Register 1

**Table 4. Wireless Power Supply Current Register 1 (READ / WRITE)**

Memory Location: 0x01, Default State: 00000001			
BIT	NAME	READ / WRITE	FUNCTION
B7 (MSB)		Read / Write	Not used
B6		Read / Write	Not used
B5		Read / Write	Not used
B4		Read / Write	Not used
B3		Read / Write	Not used
B2	$V_{OREG2}$	Read / Write	450, 500, 550, 600, 650, 700, 750, or 800 mV <sup>(1)</sup> Changes VO_REG target Default value 001
B1	$V_{OREG1}$	Read / Write	
B0	$V_{OREG0}$	Read / Write	

(1) Maximum output voltage is limited to 10 V. Maximum  $V_{O\_REG}$  setting is 0.5 V when default output voltage is set to 10 V with external resistor divider (19:1 ratio)

### 8.5.2 Wireless Power Supply Current Register 2

**Table 5. Wireless Power Supply Current Register 2 (READ / WRITE)**

Memory Location: 0x02, Default State: 00000111			
BIT	NAME	READ / WRITE	FUNCTION
B7 (MSB)	JEITA	Read / Write	Not used
B6		Read / Write	Not used
B5	$I_{TERM2}$	Read / Write	Not used.
B4	$I_{TERM1}$	Read / Write	
B3	$I_{TERM0}$	Read / Write	
B2	$I_{OREG2}$	Read / Write	10%, 20%, 30%, 40%, 50%, 60%, 80%, and 100% of $I_{LIM}$ current based on configuration 000, 001, ....111
B1	$I_{OREG1}$	Read / Write	
B0	$I_{OREG0}$	Read / Write	

### 8.5.3 Wireless Power Supply Current Register 3

**Table 6. Wireless Power Supply Current Register 3 (READ / WRITE)**

Memory Location: 0xF0, Reset State: 00000000			
BIT	NAME	READ / WRITE	FUNCTION
B7	Reserved	Read/Write	
B6	Reserved	Read / Write	
B5	Reserved	Read / Write	
B4	Reserved	Read / Write	
B3	Reserved	Read / Write	
B2	Reserved	Read / Write	
B1	I2C_ILIM	Read / Write	Set bit to 1 to disable 2x current limit scaling between low-power and proprietary modes. Must be set to 1 to correctly adjust the current limit for each mode through I <sup>2</sup> C
B0	Reserved	Read / Write	

### 8.5.4 I<sup>2</sup>C Mailbox Register

**Table 7. I<sup>2</sup>C Mailbox Register (READ / WRITE)**

Memory Location: 0xE0, Reset State: 10000000			
BIT	NAME	READ / WRITE	FUNCTION
B7	USER_PKT_DONE	Read/Write	Set bit to 0 to send proprietary packet with header in 0xE2. CPU checks header to pick relevant payload from 0xF1 to 0xF4. This bit will be set to 1 after the user packet with the header in register 0xE2 is sent.
B6	USER_PKT_ERR	Read	00 = No error in sending packet 01 = Error: No transmitter present 10 = Illegal header found: packet will not be sent 11 = Error: Not defined yet
B5			
B4	FOD Mailer	Read / Write	Not used
B3	ALIGN Mailer	Read / Write	Setting this bit to 1 enables alignment aid mode where the CEP = 0 is sent until this bit is set to 0 (or CPU reset occurs)
B2	FOD Scaler	Read / Write	Not used, write to 0 if register is written
B1	Reserved	Read / Write	
B0	Reserved	Read / Write	

### 8.5.5 I<sup>2</sup>C Mailbox Register 2

**Table 8. I<sup>2</sup>C Mailbox Register 2 (READ / WRITE)**

Memory Location: 0xEF, Reset State: 00000000			
BIT	NAME	READ / WRITE	FUNCTION
B7	<u>P</u> MODE	Read	Power mode 0 = Low-power mode 5 W 1 = Proprietary 10 W
B6	Reserved	Read / Write	
B5	Reserved	Read / Write	
B4	Reserved	Read / Write	
B3	Reserved	Read / Write	
B2	Reserved	Read / Write	
B1	Reserved	Read / Write	
B0	Reserved	Read / Write	

### 8.5.6 I<sup>2</sup>C Mailbox Register 3

**Table 9. I<sup>2</sup>C Mailbox Register 3 (READ)**

Memory Location: 0xFB, Reset State: 00000000			
BIT	NAME	READ / WRITE	FUNCTION
B7	FREQ7	Read	Power signal frequency. See <a href="#">Equation 11</a> for calculation.
B6	FREQ6	Read	
B5	FREQ5	Read	
B4	FREQ4	Read	
B3	FREQ3	Read	
B2	FREQ2	Read	
B1	FREQ1	Read	
B0	FREQ0	Read	

### 8.5.7 Wireless Power Supply FOD RAM

**Table 10. Wireless Power Supply FOD RAM (READ / WRITE)**

Memory Location: 0xE1, Reset State: 00000000 <sup>(1)</sup>			
BIT	NAME	READ / WRITE	FUNCTION
B7 (MSB)	ESR_ENABLE	Read / Write	Enables I <sup>2</sup> C based ESR in received power, Enable = 1, Disable = 0
B6	OFF_ENABLE	Read / Write	Enables I <sup>2</sup> C based offset power, Enable = 1, Disable = 0
B5	R <sub>FOD5</sub>	Read / Write	000 = 0 mW 001 = 78 mW 010 = 156 mW 011 = 234 mW 100 = 312 mW 101 = 390 mW 110 = 468 mW 111 = 546 mW The value is added to received power message
B4	R <sub>FOD4</sub>	Read / Write	
B3	R <sub>FOD3</sub>	Read / Write	
B2	R <sub>FOD2</sub>	Read / Write	
B1	R <sub>FOD1</sub>	Read / Write	000 = ESR 001 = ESR 010 = ESR × 2 011 = ESR × 3 100 = ESR × 4 101 = ESR 110 = ESR 111 = ESR × 0.5
B0	R <sub>FOD0</sub>	Read / Write	

(1) A non-zero value changes the I<sup>2</sup>R calculation resistor and offset in the received power calculation by a factor shown in the table.

### 8.5.8 Wireless Power User Header RAM

**Table 11. Wireless Power User Header RAM (WRITE)**

Memory Location: 0xE2, Reset State: 00000000 <sup>(1)</sup>	
BIT	READ / WRITE
B7 (MSB)	Read / Write
B6	Read / Write
B5	Read / Write
B4	Read / Write
B3	Read / Write
B2	Read / Write
B1	Read / Write
B0	Read / Write

(1) Must write a valid WPC v1.2 Proprietary Packet Header to enable proprietary package. Reserved headers (Control Error Packet, Received Power Packet, and so forth) may not be used. As soon as mailer (0xE0) is written, payload bytes are sent on the next available communication slot as determined by CPU. When payload is sent, the mailer (USER\_PKT\_DONE) is set to 1.

### 8.5.9 Wireless Power USER V<sub>RECT</sub> Status RAM

**Table 12. Wireless Power USER V<sub>RECT</sub> Status RAM (READ)**

Memory Location: 0xE3, Reset State: 00000000 Range – 0 to 12 V This register reads back the V <sub>RECT</sub> voltage with LSB = 46 mV			
BIT	NAME	READ / WRITE	FUNCTION
B7 (MSB)	V <sub>RECT7</sub>	Read	LSB = 46 mV
B6	V <sub>RECT6</sub>	Read	
B5	V <sub>RECT5</sub>	Read	
B4	V <sub>RECT4</sub>	Read	
B3	V <sub>RECT3</sub>	Read	
B2	V <sub>RECT2</sub>	Read	
B1	V <sub>RECT1</sub>	Read	
B0	V <sub>RECT0</sub>	Read	

**8.5.10 Wireless Power V<sub>OUT</sub> Status RAM**
**Table 13. Wireless Power V<sub>OUT</sub> Status RAM (READ)**

Memory Location: 0xE4, Reset State: 00000000 This register reads back the V <sub>OUT</sub> voltage with LSB = 46 mV			
BIT	NAME	Read / Write	FUNCTION
B7 (MSB)	VOUT7	Read / Write	LSB = 46 mV
B6	VOUT6	Read / Write	
B5	VOUT5	Read / Write	
B4	VOUT4	Read / Write	
B3	VOUT3	Read / Write	
B2	VOUT2	Read / Write	
B1	VOUT1	Read / Write	
B0	VOUT0	Read / Write	

**8.5.11 Wireless Power Proprietary Mode REC PWR MSByte Status RAM**
**Table 14. Wireless Power Proprietary Mode REC PWR MSByte Status RAM (READ)<sup>(1)</sup>**

Memory Location: 0xE7, Reset State: 00000000 This register reads back the MSByte for received power in Proprietary 10-W Mode only		
BIT		Read / Write
B7 (MSB)		Read / Write
B6		Read / Write
B5		Read / Write
B4		Read / Write
B3		Read / Write
B2		Read / Write
B1		Read / Write
B0		Read / Write

(1) For proprietary mode, Received power (mW) = (10000/128) × REC PWR MSByte + (10000 / (256 × 128)) × REC PWR LSByte

**8.5.12 Wireless Power REC PWR LSByte Status RAM**
**Table 15. Wireless Power REC PWR LSByte Status RAM (READ)<sup>(1)</sup>**

Memory Location: 0xE8, Reset State: 00000000		
BIT		Read / Write
B7 (MSB)		Read / Write
B6		Read / Write
B5		Read / Write
B4		Read / Write
B3		Read / Write
B2		Read / Write
B1		Read / Write
B0		Read / Write

(1) This register reads back the received power in low-power mode with LSB = 39 mW. In proprietary mode, this register reads back the LSByte for received power.



**8.5.13 Wireless Power Prop Packet Payload RAM Byte 0**
**Table 16. Wireless Power Prop Packet Payload RAM Byte 0 (WRITE)**

Memory Location: 0xF1, Reset State: 00000000		
BIT		Read / Write
B7 (MSB)		Read / Write
B6		Read / Write
B5		Read / Write
B4		Read / Write
B3		Read / Write
B2		Read / Write
B1		Read / Write
B0		Read / Write

**8.5.14 Wireless Power Prop Packet Payload RAM Byte 1**
**Table 17. Wireless Power Prop Packet Payload RAM Byte 1 (WRITE)**

Memory Location: 0xF2, Reset State: 00000000		
BIT		Read / Write
B7 (MSB)		Read / Write
B6		Read / Write
B5		Read / Write
B4		Read / Write
B3		Read / Write
B2		Read / Write
B1		Read / Write
B0		Read / Write

**8.5.15 Wireless Power Prop Packet Payload RAM Byte 2**
**Table 18. Wireless Power Prop Packet Payload RAM Byte 2 (WRITE)**

Memory Location: 0xF3, Reset State: 00000000		
BIT		Read / Write
B7 (MSB)		Read / Write
B6		Read / Write
B5		Read / Write
B4		Read / Write
B3		Read / Write
B2		Read / Write
B1		Read / Write
B0		Read / Write

**8.5.16 Wireless Power Prop Packet Payload RAM Byte 3**
**Table 19. Wireless Power Prop Packet Payload RAM Byte 3 (WRITE)**

Memory Location: 0xF4, Reset State: 00000000		
BIT		Read / Write
B7 (MSB)		Read / Write
B6		Read / Write
B5		Read / Write
B4		Read / Write
B3		Read / Write
B2		Read / Write
B1		Read / Write
B0		Read / Write

## 9 Application and Implementation

### NOTE

Information in the following applications sections is not part of the TI component specification, and TI does not warrant its accuracy or completeness. TI's customers are responsible for determining suitability of components for their purposes. Customers should validate and test their design implementation to confirm system functionality.

### 9.1 Application Information

The bq51025 device complies with WPC v1.2 standard. There are several tools available for the design of the system. Obtain these tools by checking the product page at [www.ti.com](http://www.ti.com). The following sections detail how to design a WPC v1.2 mode RX system.

### 9.2 Typical Applications

#### 9.2.1 WPC v1.2 Power Supply 7-V Output With 1.4-A Maximum Current With I<sup>2</sup>C

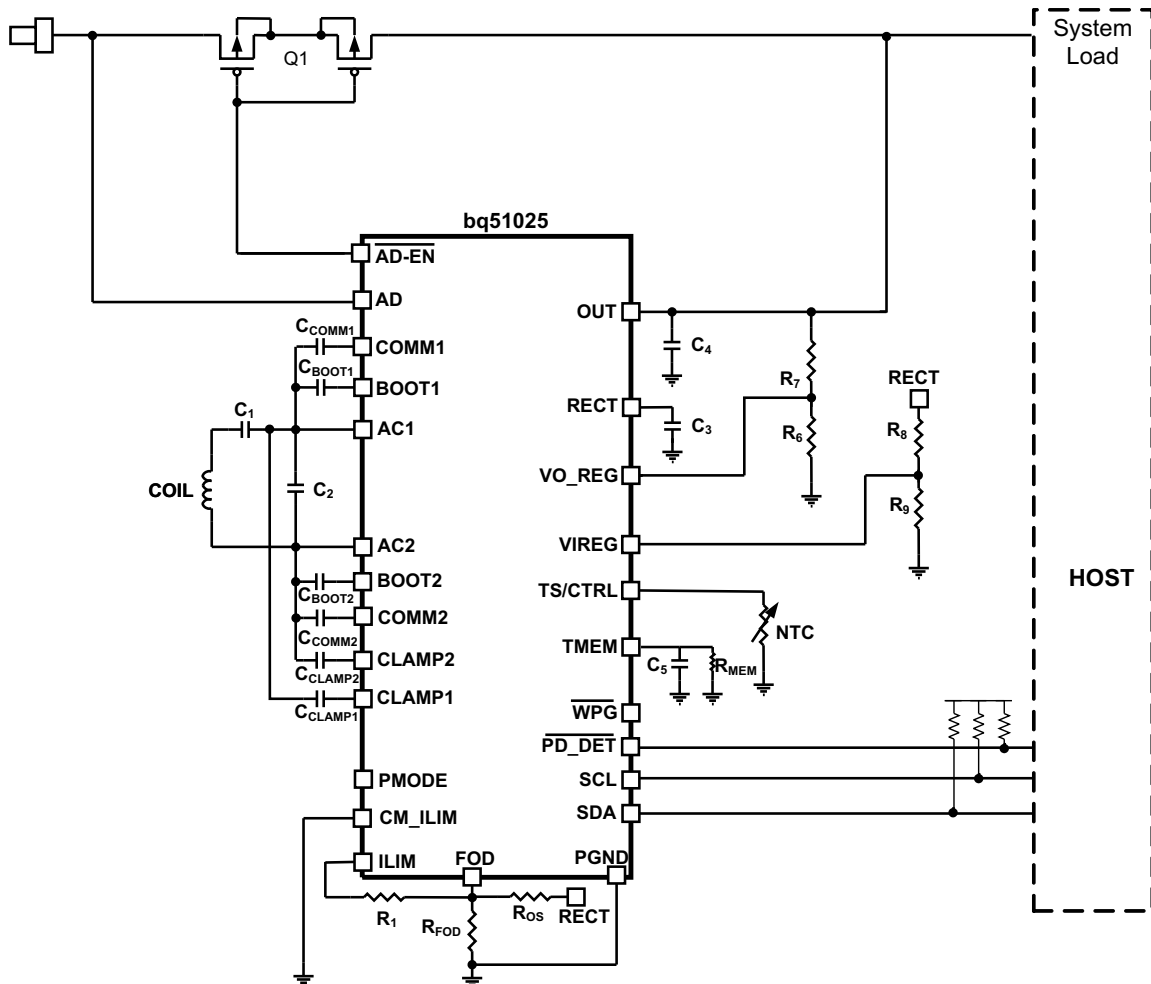

Copyright © 2016, Texas Instruments Incorporated

Figure 14. Schematic Using bq51025

## Typical Applications (continued)

### 9.2.1.1 Design Requirements

Table 20 shows the design parameters.

**Table 20. Design Parameters**

DESIGN PARAMETER	EXAMPLE VALUE
$V_{OUT}$	7 V
$I_{OUT}$ MAXIMUM	1.4 A

### 9.2.1.2 Detailed Design Procedure

To start the design procedure, determine the following:

- Output voltage
- Maximum output current

#### 9.2.1.2.1 Output Voltage Set Point

The output voltage of the bq51025 device can be set by adjusting a feedback resistor divider network. The resistor divider network is used to set the voltage gain at the VO\_REG pin. The device is intended to operate where the voltage at the VO\_REG pin is set to 0.5 V. This value is the default setting and can be changed through I<sup>2</sup>C. In Figure 15, R<sub>6</sub> and R<sub>7</sub> are the feedback network for the output voltage sense.

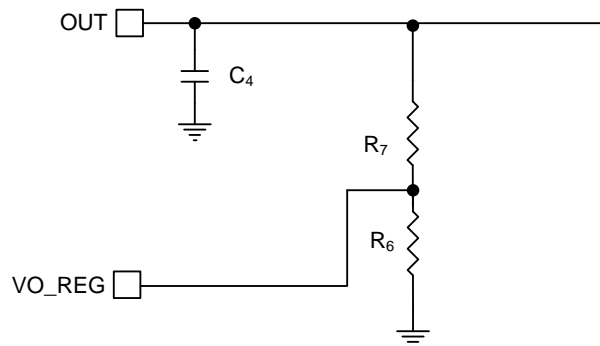

**Figure 15. Voltage Gain for Feedback**

$$K_{VO} = \frac{0.5 \text{ V}}{V_{OUT}} \quad (12)$$

$$R_6 = \frac{K_{VO} \times R_7}{1 - K_{VO}} \quad (13)$$

Choose R<sub>7</sub> to be a standard value. In this case, take care to choose R<sub>6</sub> and R<sub>7</sub> to be fairly large values so as to not dissipate an excessive amount of power in the resistors and thereby lower efficiency.

K<sub>VO</sub> is set to be 0.5 / 7 = 1/14, choose R<sub>7</sub> to be 130 kΩ, and thus R<sub>6</sub> to be 10 kΩ.

After R<sub>6</sub> and R<sub>7</sub> are chosen, the same values should be used on the VI\_REG resistor divider (R<sub>9</sub> and R<sub>8</sub>). This allows the device to regulate the rectifier voltage properly and accurately track the output voltage.

#### 9.2.1.2.2 Output and Rectifier Capacitors

Set C<sub>4</sub> between 1 and 4.7 μF. This example uses 3.3 μF.

Set C<sub>3</sub> between 22 and 44 μF. This example uses 44 μF to minimize output ripple.

### 9.2.1.2.3 TMEM

Set  $C_5$  to 2.2  $\mu\text{F}$ . To determine the bleedoff resistor, the WPC transmitters (for which the  $\overline{\text{PD\_DET}}$  is being set for) needs to be determined. After the ping timing (time between two consecutive digital pings after EPT charge complete is sent) is determined, the bleedoff resistor  $R_{\text{MEM}}$  can be determined. This example uses TI transmitter EVMs as the use case. In this case, the time between pings is 5 s. To set the time constant using Equation 9,  $R_{\text{MEM}}$  is set to 560 k $\Omega$ .

### 9.2.1.2.4 Maximum Output Current Set Point

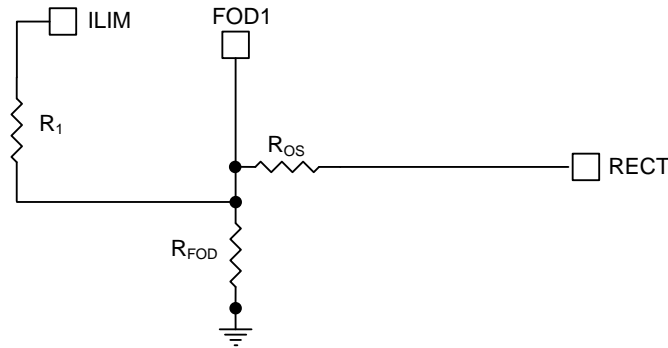

Figure 16. Current Limit Setting for bq51025

The bq51025 device includes a means of providing hardware overcurrent protection by means of an analog current regulation loop. The hardware current limit provides a level of safety by clamping the maximum allowable output current (for example, a current compliance). The  $R_{\text{ILIM}}$  resistor size also sets the thresholds for the dynamic rectifier levels, and thus providing efficiency tuning per each application's maximum system current. The calculation for the total  $R_{\text{ILIM}}$  resistance is as follows:

$$R_{\text{ILIM}} = \frac{K_{\text{ILIM}}}{I_{\text{ILIM}}} \quad (14)$$

$$R_1 = R_{\text{ILIM}} - R_{\text{FOD}} \quad (15)$$

The  $R_{\text{ILIM}}$  allows for the ILIM pin to reach 1.2 V at an output current equal to  $I_{\text{ILIM}}$  in 10-W mode and reach 0.6 V in 5-W mode. When choosing  $I_{\text{ILIM}}$ , consider two possible operating conditions:

- If the application requires an output current equal to or greater than external  $I_{\text{LIM}}$  that the circuit is designed for (input current limit on the charger where the RX is delivering power to is higher than the external  $I_{\text{LIM}}$ ), ensure that the downstream charger is capable of regulating the voltage of the input into which the RX device output is tied to by lowering the amount of current being drawn. This ensures that the RX output does not collapse. Such behavior is referred to as VIN DPM in TI chargers. Unless such behavior is enabled on the charger, the charger pulls the output of the RX device to ground when the RX device enters current regulation.
- If the applications are designed to extract less than the  $I_{\text{MAX}}$ , typical designs should leave a design margin of at least 20% so that the voltage at ILIM pin reaches 1.2 V when 20% more than maximum current of the system ( $I_{\text{MAX}}$ ) is drawn from the output of the RX. Such a design would have input current limit on the charger lower than the external current limit of the RX device.

In both cases, however, the charger must be capable of regulating the current drawn from the device to allow the output voltage to stay at a reasonable value. This same behavior is also necessary during the WPC v1.2 Communication. See [Communication Current Limit](#) for more details. The following calculations show how such a design is achieved:

$$R_{\text{ILIM}} = \frac{K_{\text{ILIM}}}{1.2 \times I_{\text{ILIM}}} \quad (16)$$

$$R_1 = R_{\text{ILIM}} - R_{\text{FOD}} \quad (17)$$

When referring to the application diagram shown in [Figure 16](#),  $R_{ILIM}$  is the sum of the  $R_1$  and  $R_{FOD}$  resistance (that is, the total resistance from the ILIM pin to GND).  $R_{FOD}$  is chosen according to the FOD application note that can be obtained by contacting your TI representative. This is used to allow the RX implementation to comply with WPC v1.2 requirements related to received power accuracy.

Also note that in many applications, the resistor  $R_{OS}$  is necessary to comply with WPC v1.2 requirements. In such a case, the offset on the FOD pin from the voltage on  $R_{FOD}$  can cause a shift in the calculation that can reduce the expected current limit. Therefore, it is always a good idea to check the output current limit after FOD calibration is performed according to the FOD section. Unfortunately, because the RECT voltage is not deterministic, and depends on transmitter operation to a certain degree, it is not possible to determine  $R_1$  with  $R_{OS}$  present in a deterministic manner.

In this example, set maximum current for the example to be 1.4 A at 10 W and 700 mA at 5-W mode. Set  $I_{ILIM} = 1.7$  A to allow for the 20% margin.

$$R_{ILIM} = \frac{842}{1.7A} = 495\Omega \quad (18)$$

#### 9.2.1.2.5 I<sup>2</sup>C

The I<sup>2</sup>C lines are used to communicate with the device. To enable the I<sup>2</sup>C, they can be pulled up to an internal host bus. The device address is 0x6C.

#### 9.2.1.2.6 Communication Current Limit

Communication current limit allows the device to communicate with the transmitter in an error-free manner by decoupling the coil from load transients on the OUT pin during WPC communication. In some cases, this communication current limit feature is not desirable. In this design, the user enables the communication current limit by tying the CM\_ILIM pin to GND. If this is not needed, the CM\_ILIM pin can be tied to the OUT pin to disable the communication current limit. In this case, take care that the voltage on the CM\_ILIM pin does not exceed the maximum rating of the pin.

#### 9.2.1.2.7 Receiver Coil

The receiver coil design is the most open part of the system design. The choice of the receiver inductance, shape, and materials all intimately influence the parameters themselves in an intertwined manner. This design can be complicated and involves optimizing many different aspects; refer to the EVM user's guide ([SLUUB55](#)).

The typical choice of the inductance of the receiver coil for a 10-W, 7-V solution is between 15 and 16  $\mu$ H.

#### 9.2.1.2.8 Series and Parallel Resonant Capacitors

Resonant capacitors,  $C_1$  and  $C_2$ , are set according to WPC specification.

The equations for calculating the values of the resonant capacitors are shown:

$$C_1 = \left[ (f_S \times 2\pi)^2 \times L'_S \right]^{-1}$$

$$C_2 = \left[ (f_D \times 2\pi)^2 \times L_S - \frac{1}{C_1} \right]^{-1} \quad (19)$$

Because the bq51025 can provide up to 10 W of output power, TI highly recommends that the resonant capacitors have very-low ESR and dissipate as little power as possible for better thermal performance. TI highly recommends NP0/C0G ceramic material capacitors.

#### 9.2.1.2.9 Communication, Boot, and Clamp Capacitors

Set  $C_{COMMx}$  to a value ranging from  $C_1 / 8$  to  $C_1 / 3$ . The higher the value of the communication capacitors, the easier it is to comply with the WPC specification. However, higher capacitors do lower the overall efficiency of the system. Make sure these are X7R ceramic material and have a minimum voltage rating of 25 V.

Set  $C_{BOOTx}$  as 15 nF. Make sure these are X7R ceramic material and have a minimum voltage rating of 25 V.

Set  $C_{CLAMPx}$  as 470 nF. Make sure these are X7R ceramic material and have a minimum voltage rating of 25 V.

9.2.1.3 Application Curves

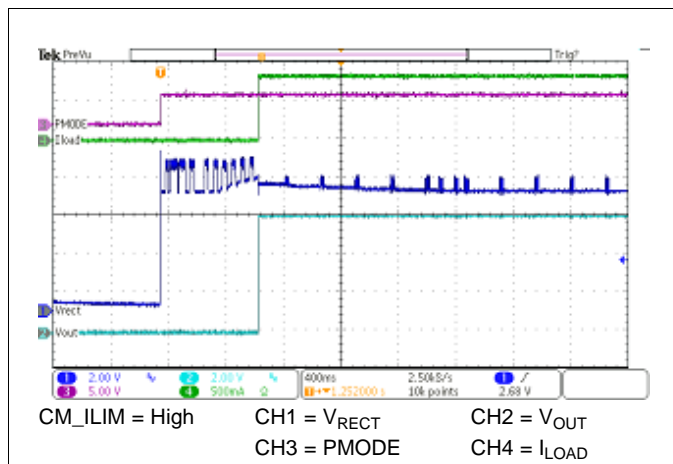

Figure 17. 7-V RX Start-Up With 9-Ω Load on a 5-W WPC TX

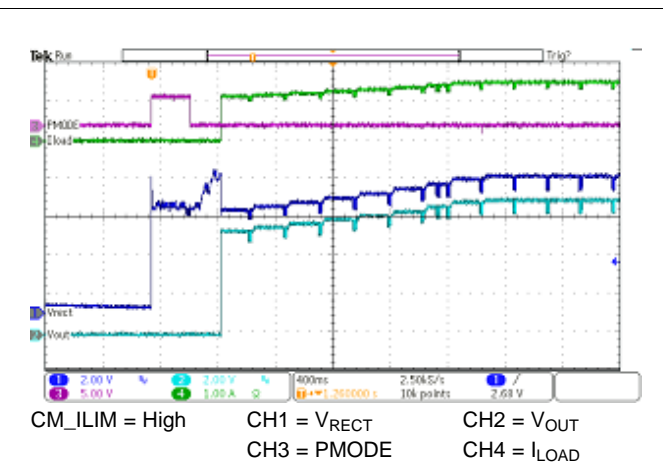

Figure 18. 7-V RX Start-Up With 5-Ω Load on a bq500215 TX

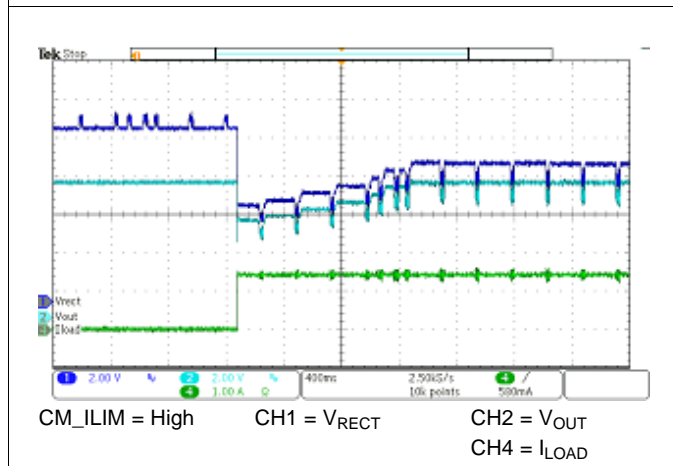

Figure 19. 0- to 1450-mA Step with 7-V RX on bq500215 TX

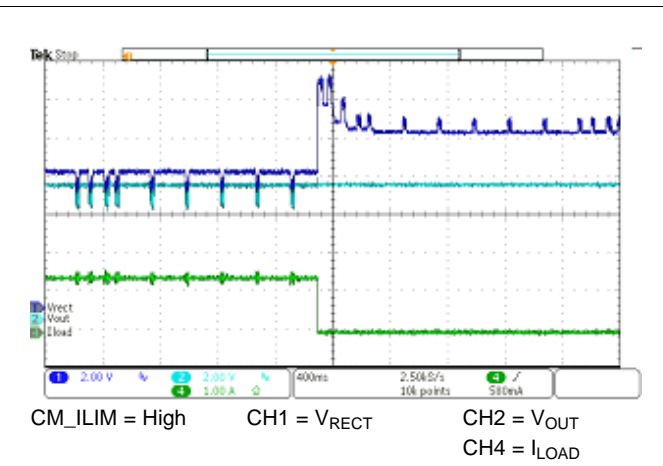

Figure 20. 1450- to 0-mA Load Dump with 7-V RX on bq500215 TX

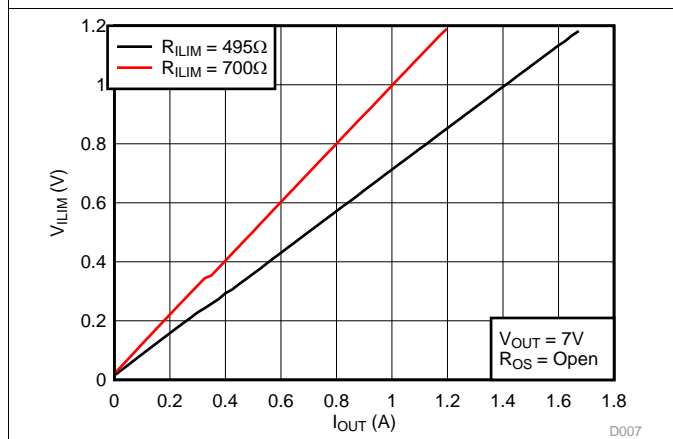

Figure 21. ILIM Voltage as a Function of Load Current

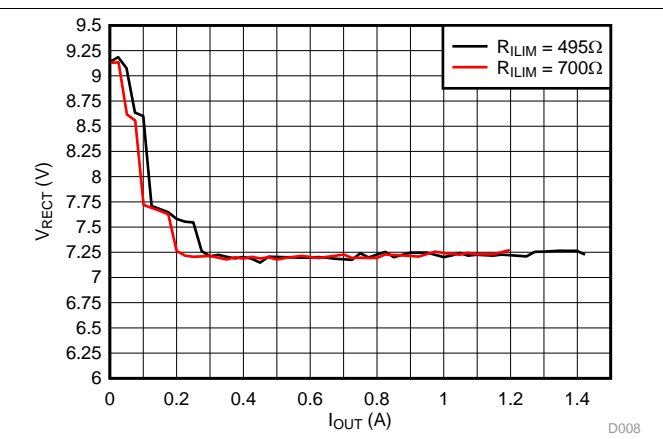

Figure 22. Rectifier Regulation as a Function of R\_ILIM on bq500215 TX, 7-V RX

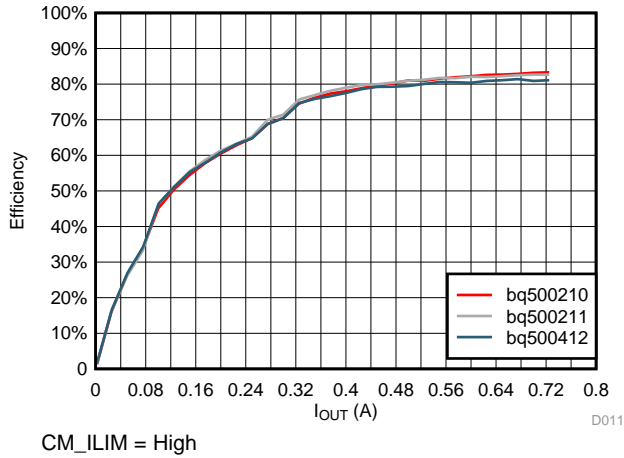

Figure 23. Efficiency on Various 5-W WPC TX, 7-V RX

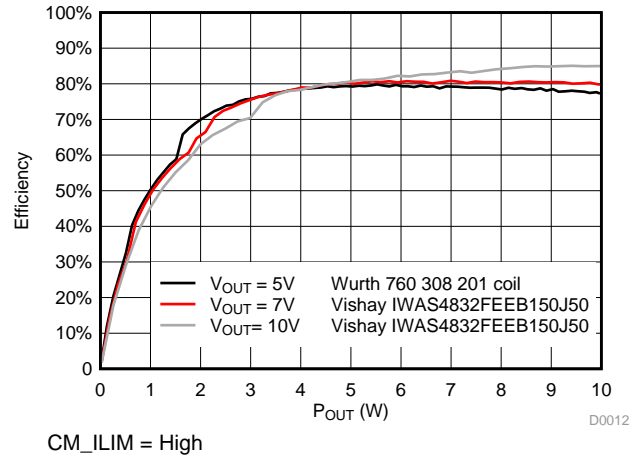

Figure 24. Efficiency on 10-W bq500215 TX

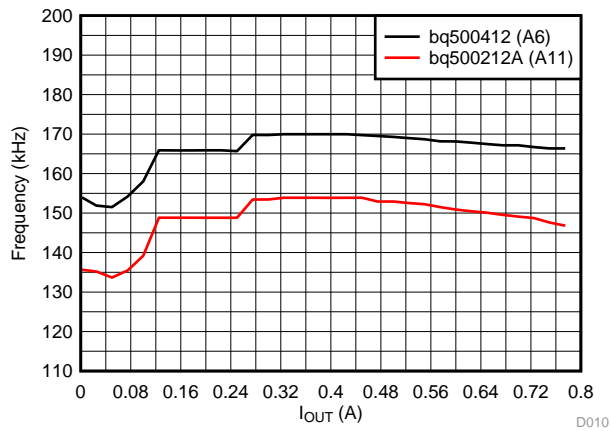

Figure 25. Frequency Range of 7-V, 5-W Mode on a WPC TX

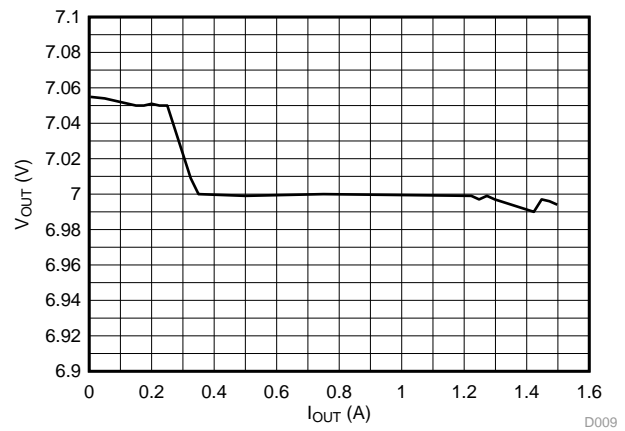

Figure 26. Output Regulation on bq500215 TX

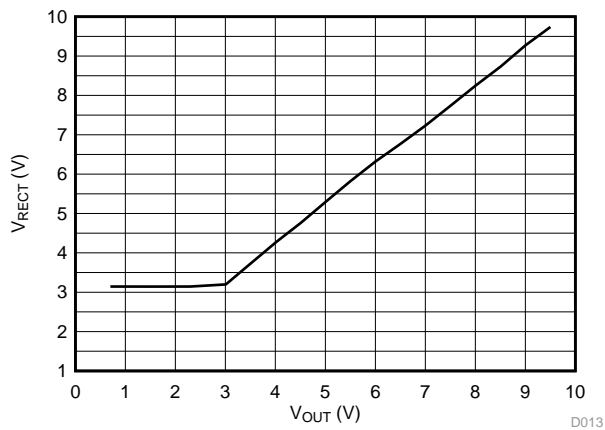

Figure 27.  $V_{RECT}$  Foldback in Current Limit on a WPC TX

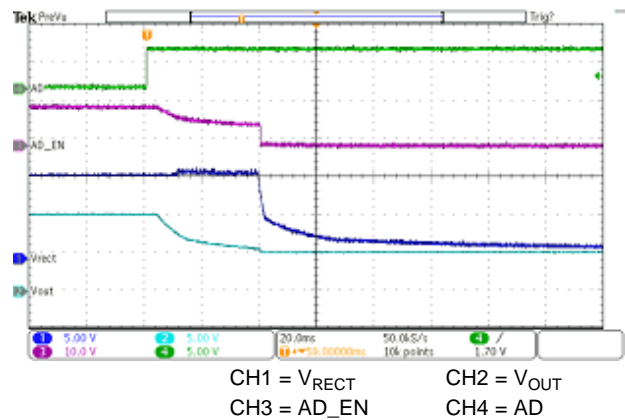

Figure 28. AD\_EN Functionality upon 5-V USB Connection, 10-V RX, No Load



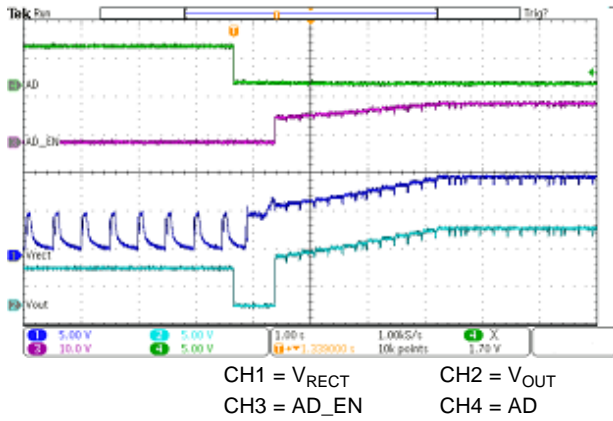

Figure 29. AD\_EN Functionality upon 5-V USB Removal, 10-V RX, 1-A Load

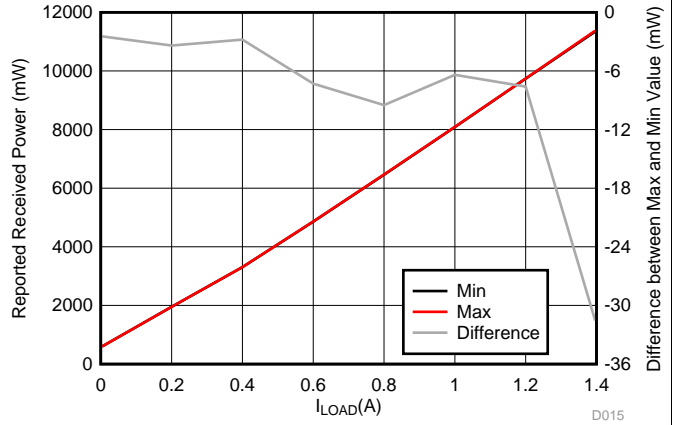

Figure 30. Received Power Variation (mW) vs I<sub>OUT</sub> (mA) on a WPC TX

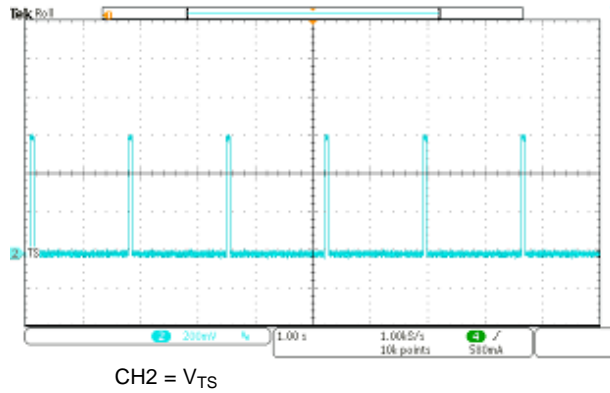
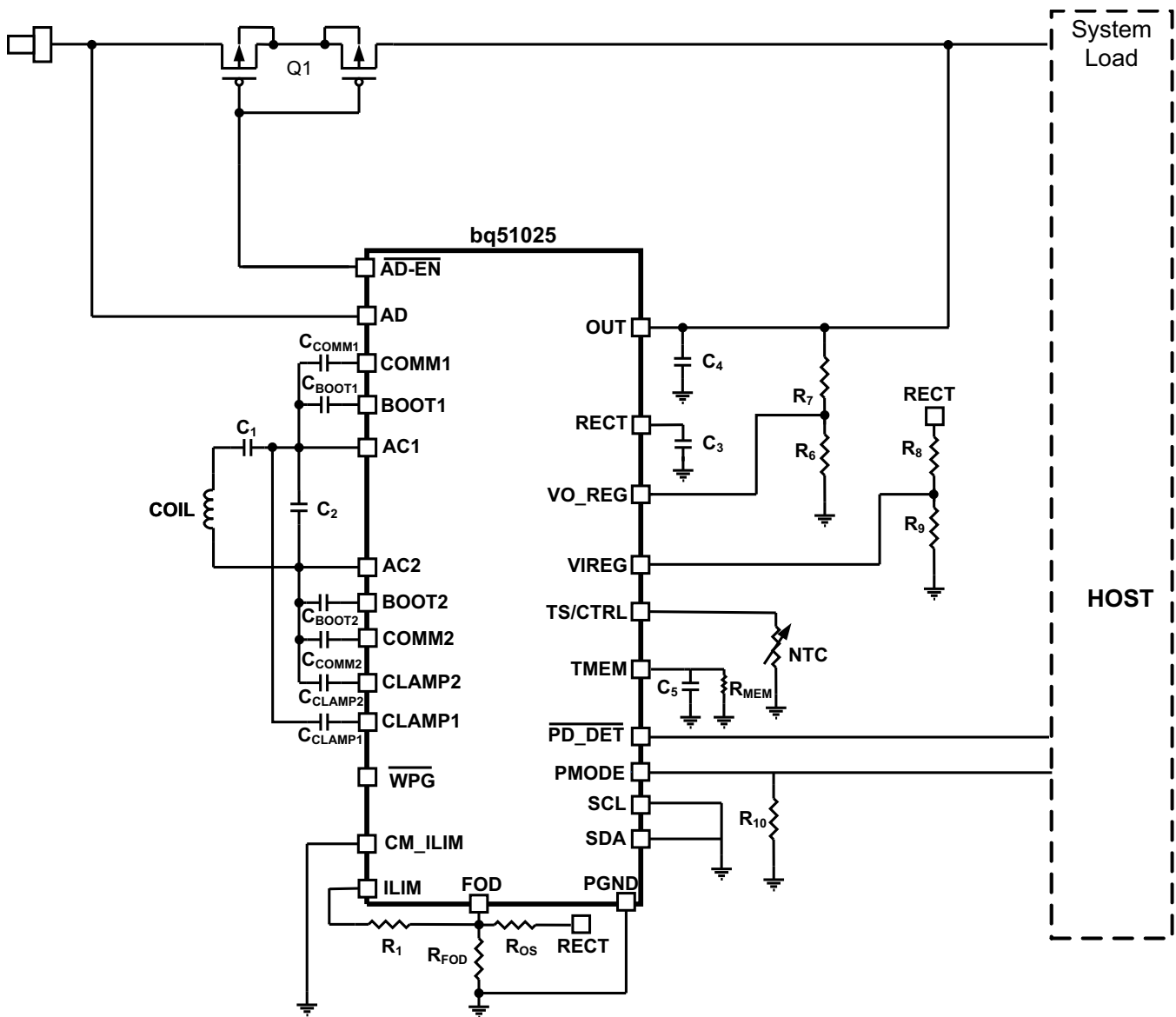

Figure 31. TS Voltage Bias Without TS Resistor

### 9.2.2 Standalone 10-V WPC v1.2 Power Supply With 1-A Maximum Output Current in System Board

When the bq5102x device is implemented as an embedded device on the system board, the same design procedure as for an I<sup>2</sup>C system should be used, but the I<sup>2</sup>C pins are to be connected to ground. The VO\_REG and VIREG resistor dividers are chosen to achieve 10-V output and R<sub>ILIM</sub> is chosen to allow a maximum current of 1 A (I<sub>ILIM</sub> = 1.2 A for 20% margin). Refer to [WPC v1.2 Power Supply 7-V Output With 1.4-A Maximum Current With  \$\hat{P}C\$](#)  for details on how these resistor values are calculated.

A typical coil inductance for 10-V is between 15 and 17  $\mu$ H. It is important to note that even if the same receiver coil and tuning as for a 7-V RX solution are used (see [Receiver Coil](#) and [Series and Parallel Resonant Capacitors](#)), the R<sub>FOD</sub> and R<sub>OS</sub> values need to be updated to accurately determine the received power.



Copyright © 2016, Texas Instruments Incorporated

**Figure 32. bq51025 Embedded in a System Board**

### 9.2.3 Standalone 10-V Power Supply With 1-A Maximum Output Current for 2S Charging System

For the bq51025 to work properly as a supply to a 2S charger, the bq51025 output voltage must not drop below the minimum input charging voltage of the charger, which may be around 9 V depending on the charger IC. In a WPC tuned Rx/TX system, the power delivered to the load may change during Rx/Tx communication due to the capacitive modulation when  $C_{COMM1}$  and  $C_{COMM2}$  are connected from AC1 and AC2 pins to ground. If the power delivered to the load decreases, the VRECT voltage will drop and so may VOUT. If the charger IC does not have input DPM. If the power delivered to the load does not change or increases for a given current, the VRECT voltage will increase and the bq51025 will regulate the voltage.

#### NOTE

The following design example is for a 2S charging system where the charger IC does not have input DPM feature.

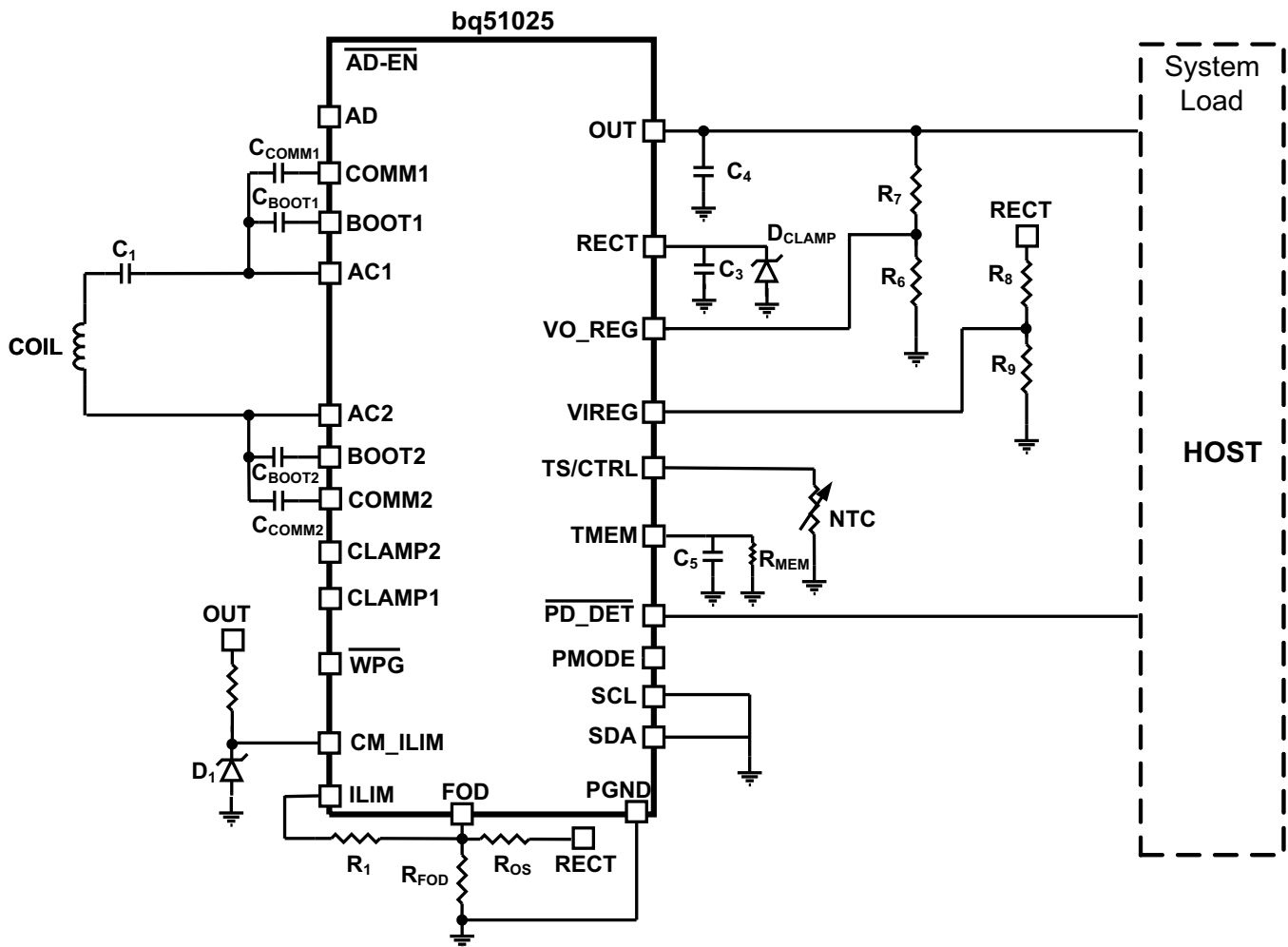

Copyright © 2016, Texas Instruments Incorporated

Figure 33. bq51025 Embedded in a 2S Battery System Board

### 9.2.3.1 Design Requirements

Table 21 shows the design parameters.

**Table 21. Design Parameters**

DESIGN PARAMETER	EXAMPLE VALUE
$V_{OUT}$	10 V
$I_{OUT\ MAXIMUM}$	1 A

### 9.2.3.2 Detailed Design Procedure

To start the design procedure, determine the following:

- Output voltage
- Maximum output current

#### 9.2.3.2.1 Output Voltage Set Point

The output voltage of the bq51025 device can be set by adjusting a feedback resistor divider network as described in [Output Voltage Set Point](#). The ratio of  $VO\_REG$  and  $VIREG$  resistor dividers are chosen to achieve 10-V based on the 0.5-V feedback voltage. Following [Equation 12](#) and [Equation 13](#), R6 and R7 are selected to be 11.3K $\Omega$ - and 215-k $\Omega$ , respectively. The same values are used on R9 and R8 in the  $VIREG$  divider.

#### 9.2.3.2.2 Output and Rectifier Capacitors

Set  $C_4$  to at least 3.3  $\mu$ F.

Set  $C_3$  to at least 44  $\mu$ F to minimize output ripple. Use capacitors rated for 25 V or higher.

#### 9.2.3.2.3 TMEM

Follow procedure described in [TMEM](#).

#### 9.2.3.2.4 Maximum Output Current Set Point

Follow the procedure described in [Maximum Output Current Set Point](#).

#### 9.2.3.2.5 I<sup>2</sup>C

Connect I<sup>2</sup>C lines to ground.

#### 9.2.3.2.6 Communication Current Limit

Communication current limit must be disabled. Connect  $CM\_ILIM$  pin to voltage supply making sure it does not exceed maximum absolute rating for the pin. If only the battery voltage is available, use a 5-V Zener diode ( $D_1$ ) to clamp the voltage.

#### 9.2.3.2.7 Receiver Coil

The receiver coil design is the most open part of the system design. The choice of the receiver inductance, shape, and materials all intimately influence the parameters themselves in an intertwined manner. This design can be complicated and involves optimizing many different aspects. The typical choice of the inductance of the receiver coil for a 10-W, 10-V solution is between 15 and 16  $\mu$ H.

#### 9.2.3.2.8 Series Resonant Capacitors

In order for the bq51025 to work properly as a supply to a 2S charger, the bq51025 output voltage must not drop below the minimum input charging voltage of the charger, which may be around 9 V depending on the charger IC. In a WPC tuned Rx/Tx system, the power delivered to the load may change during Rx/Tx communication due to the capacitive modulation when  $C_{COMM1}$  and  $C_{COMM2}$  are connected from AC1 and AC2 pins to ground. If the power delivered to the load decreases, the  $V_{RECT}$  voltage will drop and so may  $V_{OUT}$  if the charger IC does not have VIN-DPM function. If the power delivered to the load does not change or increases for a given current, the  $V_{RECT}$  voltage will increase and the bq51025 will regulate the voltage to a fixed value. The following section discusses the tuning procedure to ensure that the output voltage level is maintained during communication when operating with a bq51025 based transmitter.

### 9.2.3.2.8.1 Tuning Procedure

#### NOTE

The following tuning procedure results in a system that is not compliant with WPC specification and is only designed to operate with a given bq500215 based transmitter.

1. Measure the effective self-inductance of the bq500215 based transmitter (primary) coil,  $L_P'$ , and receiver (secondary) coil,  $L_S'$ . The measurements must be done on the final charging system setup (that is, battery and any other friendly metal of the device is included as well as any cover material that determines the distance between the coil and charging surface). Make the measurement at the optimal alignment position.
2. Measure the mutual inductance,  $L_M$  and calculate the coupling factor given by:

$$k = \frac{L_M}{\sqrt{L_S' L_P'}} \quad (20)$$

3. A first-order approximation of the series capacitance is given by:

$$C_1 = \frac{1}{(2\pi f)^2 L_S' (1 - k^2) - \frac{k^2 L_S'}{C_P L_P'} - 4\pi f} \quad (21)$$

Where  $f$  is the operating frequency of the transmitter, which is 130 kHz and  $C_P$  is the transmitter resonant capacitance which is 247 nF.

4. Make sure  $C_1$  as well as  $C_{COMM1}$  and  $C_{COMM2}$  are populated and place the receiver with best possible alignment on the transmitter and start power transfer. Using an oscilloscope, monitor the  $V_{RECT}$  voltage during communication at maximum load. If  $V_{RECT}$  decreases during communication, increase  $C_1$  until the voltage remains flat. Note that the larger the  $V_{RECT}$  voltage increase is during communication at maximum load, the larger the losses on the device. The voltage increase in  $V_{RECT}$  is larger with lower load and lower coupling, so it is important to keep the  $V_{RECT}$  voltage as low as possible during communication at maximum load and coupling to maximize efficiency across charging area and load range. [Figure 35](#) and [Figure 36](#) show how the  $V_{RECT}$  voltage behavior after tuning

### 9.2.3.2.9 Communication, Boot, and Clamp Capacitors

Set  $C_{COMMx}$  to a value ranging from  $C_1 / 8$  to  $C_1 / 3$ . Make sure these are X7R ceramic material and have a minimum voltage rating of 25 V. For this example 56-nF capacitors are chosen.

Set  $C_{BOOTx}$  as 15 nF. Make sure these are X7R ceramic material and have a minimum voltage rating of 25 V.

$C_{CLAMPx}$  is not populated since a external clamping diode is used.

#### 9.2.3.2.10 $V_{RECT}$ Clamp

Connect a 12-V Zener diode ( $D_{CLAMP}$ ) from  $V_{RECT}$  to ground. This diode prevents the rectifier voltage from overshoot above  $V_{RECT-OVP}$  level, preventing unwanted resets during large load transients during communication.

**9.2.3.3 Application Curves**

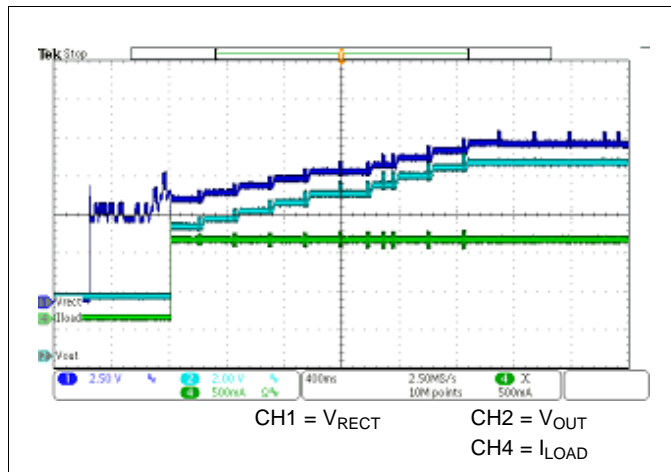

Figure 34. 10-V Tuned RX Start-Up With 1-A Load

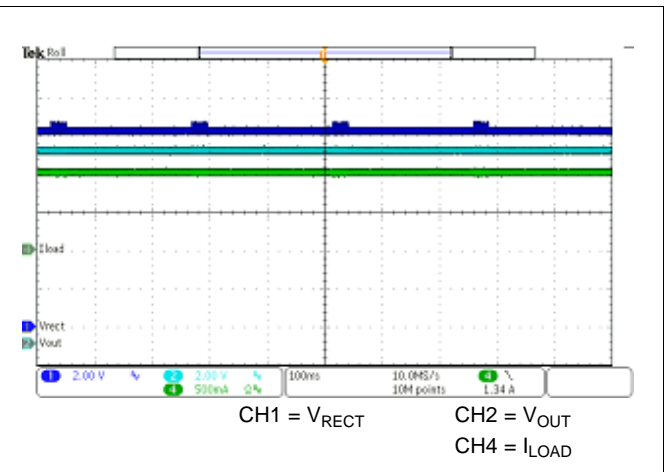

Figure 35. 10-V Tuned RX VOUT at Center Position With 1-A Load

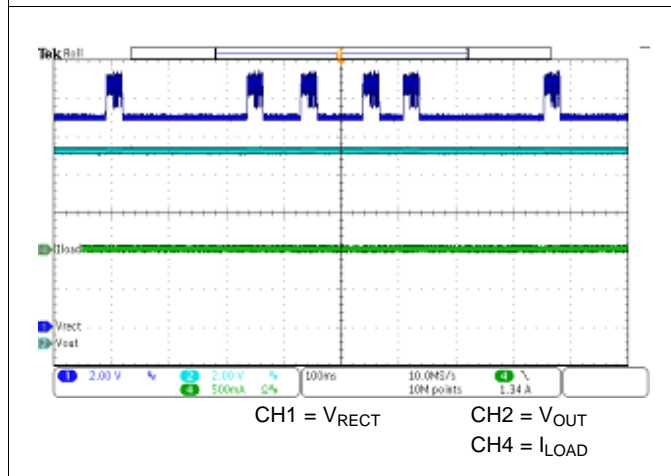

Figure 36. 10-V Tuned RX VOUT at Center Position With No load

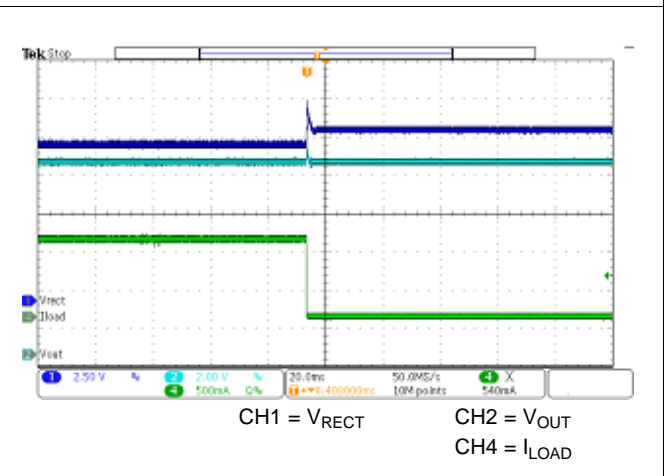

Figure 37. 1-A to 0-mA Load Dump With 10-V Tuned RX

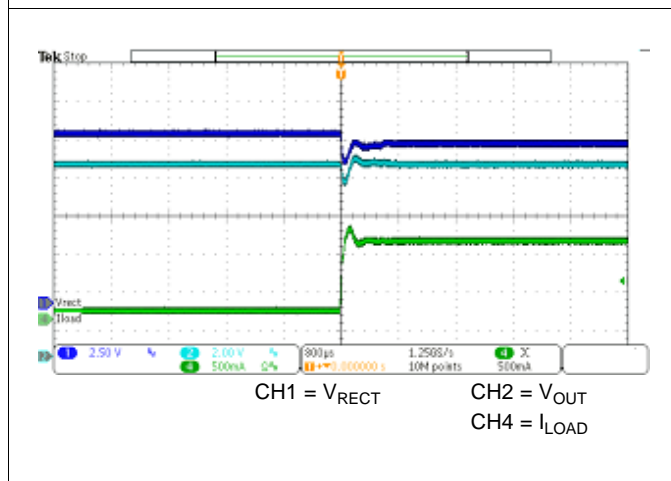

Figure 38. 100-mA to 1-A Load Transient With 10-V Tuned RX

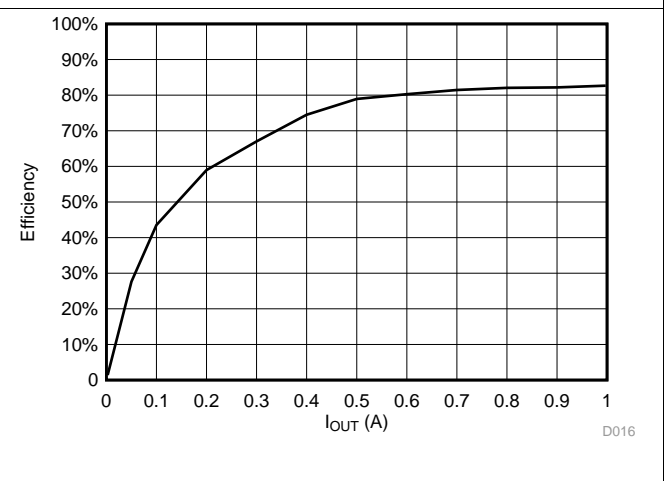

Figure 39. Efficiency With 10-V Tuned RX

## 10 Power Supply Recommendations

These devices are intended to be operated within the ranges shown in the *Recommended Operating Conditions*. Because the system involves a loosely coupled inductor setup, the voltages produced on the receiver are a function of the inductances and the available magnetic field. Ensure that the design in the worst case keeps the voltages within the *Absolute Maximum Ratings*.

## 11 Layout

### 11.1 Layout Guidelines

- Keep the trace resistance as low as possible on AC1, AC2, and OUT.
- Detection and resonant capacitors need to be as close to the device as possible.
- COMM, CLAMP, and BOOT capacitors need to be placed as close to the device as possible.
- Via interconnect on GND net is critical for appropriate signal integrity and proper thermal performance.
- High-frequency bypass capacitors need to be placed close to RECT and OUT pins.
- ILIM and FOD resistors are important signal paths and the loops in those paths to GND must be minimized.

Signal and sensing traces are the most sensitive to noise; the sensing signal amplitudes are usually measured in mV, which is comparable to the noise amplitude. Make sure that these traces are not being interfered by the noisy and power traces. AC1, AC2, BOOT1, BOOT2, COMM1, and COMM2 are the main source of noise in the board. These traces should be shielded from other components in the board. It is usually preferred to have a ground copper area placed underneath these traces to provide additional shielding. Also, make sure they do not interfere with the signal and sensing traces. The PCB should have a ground plane (return) connected directly to the return of all components through vias (two vias per capacitor for power-stage capacitors, one via per capacitor for small-signal components).

For a 1.4-A fast-charge current application, the current rating for each net is as follows:

- AC1 = AC2 = 2.2 A
- OUT = 2.5 A
- RECT = 200 mA (RMS)
- COMMx = 600 mA
- CLAMPx = 1000 mA
- All others can be rated for 10 mA or less.

### 11.2 Layout Example

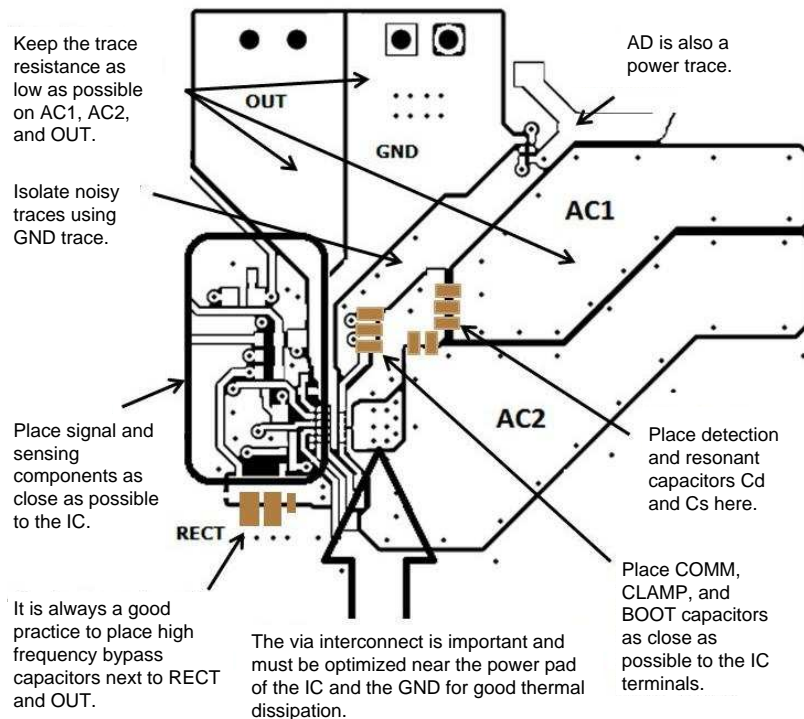

Figure 40. Layout Recommendation



## 12 器件和文档支持

### 12.1 接收文档更新通知

如需接收文档更新通知，请访问 [www.ti.com.cn](http://www.ti.com.cn) 网站上的器件产品文件夹。点击右上角的提醒我 (Alert me) 注册后，即可每周定期收到已更改的产品信息。有关更改的详细信息，请查阅已修订文档中包含的修订历史记录。

### 12.2 社区资源

The following links connect to TI community resources. Linked contents are provided "AS IS" by the respective contributors. They do not constitute TI specifications and do not necessarily reflect TI's views; see TI's [Terms of Use](#).

**TI E2E™ Online Community** *TI's Engineer-to-Engineer (E2E) Community*. Created to foster collaboration among engineers. At [e2e.ti.com](http://e2e.ti.com), you can ask questions, share knowledge, explore ideas and help solve problems with fellow engineers.

**Design Support** *TI's Design Support* Quickly find helpful E2E forums along with design support tools and contact information for technical support.

### 12.3 商标

E2E is a trademark of Texas Instruments.  
All other trademarks are the property of their respective owners.

### 12.4 静电放电警告



这些装置包含有限的内置 ESD 保护。存储或装卸时，应将导线一起截短或将装置放置于导电泡棉中，以防止 MOS 门极遭受静电损伤。

### 12.5 Glossary

[SLYZ022](#) — *TI Glossary*.

This glossary lists and explains terms, acronyms, and definitions.

## 13 机械、封装和可订购信息

以下页中包括机械、封装和可订购信息。这些信息是针对指定器件可提供的最新数据。这些数据会在无通知且不对本文档进行修订的情况下发生改变。欲获得该数据表的浏览器版本，请查阅左侧的导航栏。

**PACKAGING INFORMATION**

Orderable part number	Status (1)	Material type (2)	Package   Pins	Package qty   Carrier	RoHS (3)	Lead finish/ Ball material (4)	MSL rating/ Peak reflow (5)	Op temp (°C)	Part marking (6)
BQ51025YFPR	NRND	Production	DSBGA (YFP)   42	3000   LARGE T&R	Yes	SNAGCU	Level-1-260C-UNLIM	-40 to 125	BQ51025
BQ51025YFPR.A	NRND	Production	DSBGA (YFP)   42	3000   LARGE T&R	Yes	SNAGCU	Level-1-260C-UNLIM	-40 to 125	BQ51025
<a href="#">BQ51025YFPT</a>	NRND	Production	DSBGA (YFP)   42	250   SMALL T&R	Yes	SNAGCU	Level-1-260C-UNLIM	-40 to 125	BQ51025
BQ51025YFPT.A	NRND	Production	DSBGA (YFP)   42	250   SMALL T&R	Yes	SNAGCU	Level-1-260C-UNLIM	-40 to 125	BQ51025

(1) **Status:** For more details on status, see our [product life cycle](#).

(2) **Material type:** When designated, preproduction parts are prototypes/experimental devices, and are not yet approved or released for full production. Testing and final process, including without limitation quality assurance, reliability performance testing, and/or process qualification, may not yet be complete, and this item is subject to further changes or possible discontinuation. If available for ordering, purchases will be subject to an additional waiver at checkout, and are intended for early internal evaluation purposes only. These items are sold without warranties of any kind.

(3) **RoHS values:** Yes, No, RoHS Exempt. See the [TI RoHS Statement](#) for additional information and value definition.

(4) **Lead finish/Ball material:** Parts may have multiple material finish options. Finish options are separated by a vertical ruled line. Lead finish/Ball material values may wrap to two lines if the finish value exceeds the maximum column width.

(5) **MSL rating/Peak reflow:** The moisture sensitivity level ratings and peak solder (reflow) temperatures. In the event that a part has multiple moisture sensitivity ratings, only the lowest level per JEDEC standards is shown. Refer to the shipping label for the actual reflow temperature that will be used to mount the part to the printed circuit board.

(6) **Part marking:** There may be an additional marking, which relates to the logo, the lot trace code information, or the environmental category of the part.

Multiple part markings will be inside parentheses. Only one part marking contained in parentheses and separated by a "~" will appear on a part. If a line is indented then it is a continuation of the previous line and the two combined represent the entire part marking for that device.

**Important Information and Disclaimer:** The information provided on this page represents TI's knowledge and belief as of the date that it is provided. TI bases its knowledge and belief on information provided by third parties, and makes no representation or warranty as to the accuracy of such information. Efforts are underway to better integrate information from third parties. TI has taken and continues to take reasonable steps to provide representative and accurate information but may not have conducted destructive testing or chemical analysis on incoming materials and chemicals. TI and TI suppliers consider certain information to be proprietary, and thus CAS numbers and other limited information may not be available for release.

In no event shall TI's liability arising out of such information exceed the total purchase price of the TI part(s) at issue in this document sold by TI to Customer on an annual basis.

**TAPE AND REEL INFORMATION**

**QUADRANT ASSIGNMENTS FOR PIN 1 ORIENTATION IN TAPE**

\*All dimensions are nominal

Device	Package Type	Package Drawing	Pins	SPQ	Reel Diameter (mm)	Reel Width W1 (mm)	A0 (mm)	B0 (mm)	K0 (mm)	P1 (mm)	W (mm)	Pin1 Quadrant
BQ51025YFPR	DSBGA	YFP	42	3000	330.0	12.4	2.99	3.71	0.81	8.0	12.0	Q1
BQ51025YFPT	DSBGA	YFP	42	250	330.0	12.4	2.99	3.71	0.81	8.0	12.0	Q1

## TAPE AND REEL BOX DIMENSIONS



\*All dimensions are nominal

Device	Package Type	Package Drawing	Pins	SPQ	Length (mm)	Width (mm)	Height (mm)
BQ51025YFPR	DSBGA	YFP	42	3000	335.0	335.0	25.0
BQ51025YFPT	DSBGA	YFP	42	250	335.0	335.0	25.0

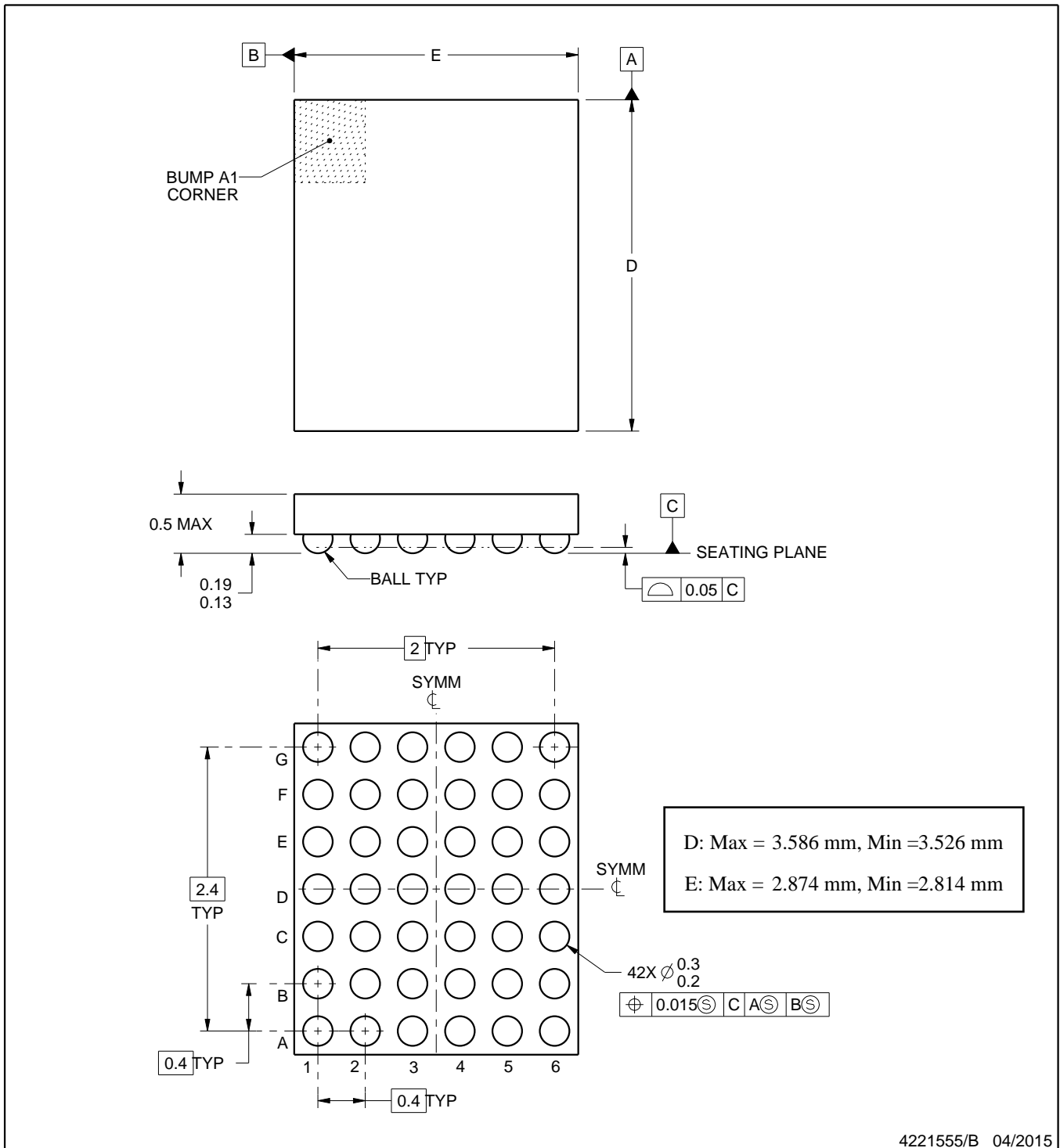
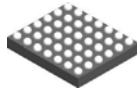

NOTES:

1. All linear dimensions are in millimeters. Any dimensions in parenthesis are for reference only. Dimensioning and tolerancing per ASME Y14.5M.
2. This drawing is subject to change without notice.

# EXAMPLE BOARD LAYOUT

YFP0042

DSBGA - 0.5 mm max height

DIE SIZE BALL GRID ARRAY

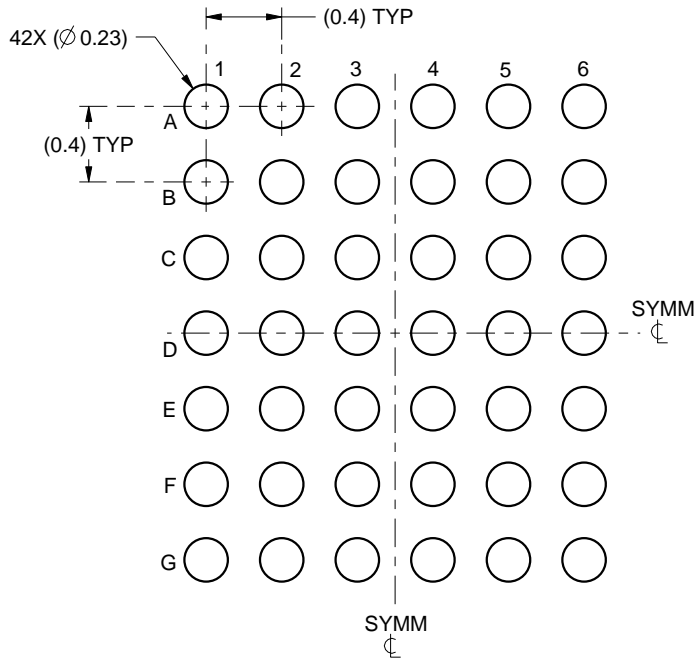

LAND PATTERN EXAMPLE  
SCALE:25X

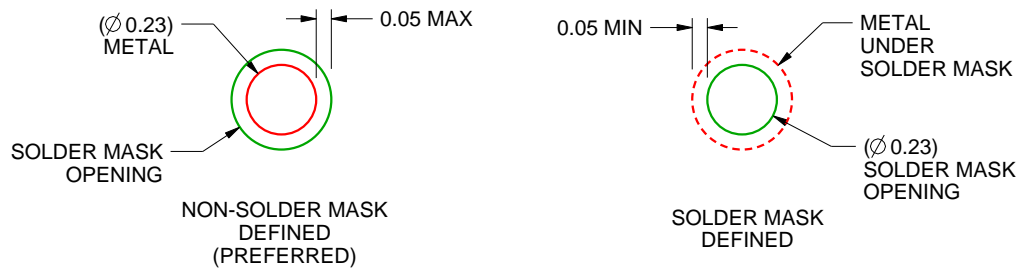

SOLDER MASK DETAILS  
NOT TO SCALE

4221555/B 04/2015

NOTES: (continued)

- Final dimensions may vary due to manufacturing tolerance considerations and also routing constraints. For more information, see Texas Instruments literature number SNVA009 ([www.ti.com/lit/snva009](http://www.ti.com/lit/snva009)).

# EXAMPLE STENCIL DESIGN

YFP0042

DSBGA - 0.5 mm max height

DIE SIZE BALL GRID ARRAY

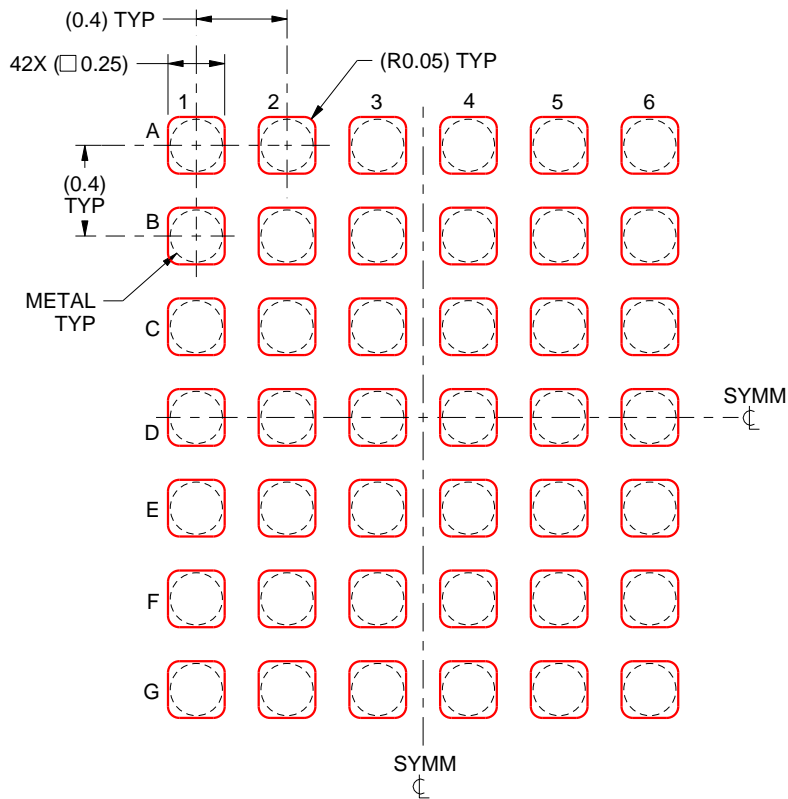

SOLDER PASTE EXAMPLE  
BASED ON 0.1 mm THICK STENCIL  
SCALE:30X

4221555/B 04/2015

NOTES: (continued)

4. Laser cutting apertures with trapezoidal walls and rounded corners may offer better paste release.

## 重要通知和免责声明

TI“按原样”提供技术和可靠性数据（包括数据表）、设计资源（包括参考设计）、应用或其他设计建议、网络工具、安全信息和其他资源，不保证没有瑕疵且不做任何明示或暗示的担保，包括但不限于对适销性、与某特定用途的适用性或不侵犯任何第三方知识产权的暗示担保。

这些资源可供使用 TI 产品进行设计的熟练开发人员使用。您将自行承担以下全部责任：(1) 针对您的应用选择合适的 TI 产品，(2) 设计、验证并测试您的应用，(3) 确保您的应用满足相应标准以及任何其他安全、安保法规或其他要求。

这些资源如有变更，恕不另行通知。TI 授权您仅可将这些资源用于研发本资源所述的 TI 产品的相关应用。严禁以其他方式对这些资源进行复制或展示。您无权使用任何其他 TI 知识产权或任何第三方知识产权。对于因您对这些资源的使用而对 TI 及其代表造成的任何索赔、损害、成本、损失和债务，您将全额赔偿，TI 对此概不负责。

TI 提供的产品受 [TI 销售条款](#)、[TI 通用质量指南](#) 或 [ti.com](#) 上其他适用条款或 TI 产品随附的其他适用条款的约束。TI 提供这些资源并不会扩展或以其他方式更改 TI 针对 TI 产品发布的适用的担保或担保免责声明。除非德州仪器 (TI) 明确将某产品指定为定制产品或客户特定产品，否则其产品均为按确定价格收入目录的标准通用器件。

TI 反对并拒绝您可能提出的任何其他或不同的条款。

版权所有 © 2025，德州仪器 (TI) 公司

最后更新日期：2025 年 10 月