

BQ27Z561-R2 Impedance Track™ Battery Gas Gauge Solution for 1-Series Cell Li-Ion Battery Packs

1 Features

- Supports high-side and low-side current sense resistors: down to 1mΩ
- Supports pack-side gauging including enhanced state of health (SOH) algorithm
- Fast QMax update option based on predicted OCV
- SHA-256 authentication responder for increased battery pack security
- Sophisticated charge algorithms
 - JEITA
 - Enhanced charging
 - RSOC() charging compensation option
- Two independent ADCs
 - Support for simultaneous current and voltage sampling
 - High-accuracy coulomb counter with input offset error: < 1 μV (typical)
- Low-voltage operation: 2V
- Wide-range current applications: 1mA to > 5A
- Active high or low pulse or level interrupt pin
- Supports battery trip point (BTP)
- Reduced power modes (typical battery pack operating range conditions)
 - Typical SLEEP mode: < 11μA
 - Typical DEEP SLEEP mode: < 9μA
 - Typical HIBERNATE mode: < 3μA
 - Typical OFF mode: < 1.9μA
- Internal and external temperature sense functions
- Diagnostic lifetime data monitor and black box recorder
- 400kHz I²C bus communications interface for high-speed programming and data access
- HDQ one-wire for communication with host
- Compact 12-pin DSBGA package (YPH)

2 Applications

- Smartphones
- Digital still cameras and video cameras
- Tablet computing
- Portable and wearable health devices
- Portable audio devices

3 Description

The Texas Instruments BQ27Z561-R2 Impedance Track™ gas gauge solution is a highly integrated, accurate 1-series cell gas gauge with a flash programmable custom reduced instruction-set CPU (RISC) and SHA-256 authentication for Li-ion and Li-polymer battery packs. The 1-series cell capability includes parallel cells for increased capacity.

The BQ27Z561-R2 gas gauge communicates through I²C-compatible and HDQ one-wire interfaces and includes several key features that can help facilitate accurate gas gauging applications. Integrated temperature sense functions (internal and external options) enable system and battery temperature measurements.

The integrated SHA-256 functionality helps enable secure identification between systems and packs. The interrupt and BTP functions facilitate the BQ27Z561-R2 device to inform the system when a specific state-of-charge (SOC), voltage, or temperature condition occurs. The low-voltage operation enables the system to continue monitoring the battery even in deeply discharged conditions. During low-activity situations, set the device to the low power coulomb counting (CC) mode, which enables the device to continue coulomb counting, while reducing operating current significantly.

Package Information

PART NUMBER	PACKAGE ⁽¹⁾	PACKAGE SIZE ⁽²⁾
BQ27Z561	DSBGA (YPH, 12)	1.69mm × 2.07mm
BQ27Z561-R2		

- (1) For all available packages, see [Section 10](#).
- (2) Updated the numbering format for tables, figures, and cross-references throughout the document.

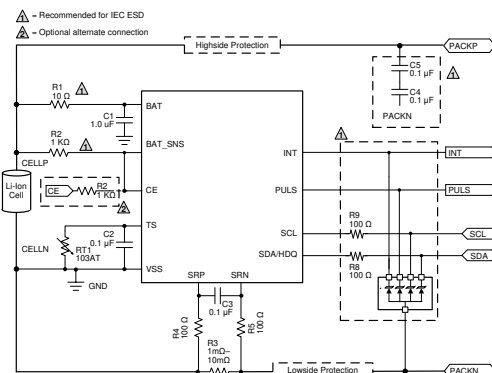

Simplified Schematic

Table of Contents

1 Features	1	5.20 HDQ Timing.....	8
2 Applications	1	5.21 Typical Characteristics.....	10
3 Description	1	6 Detailed Description	11
4 Pin Configuration and Functions	3	6.1 Overview.....	11
5 Specifications	4	6.2 Functional Block Diagram.....	11
5.1 Absolute Maximum Ratings.....	4	6.3 Feature Description.....	11
5.2 ESD Ratings.....	4	6.4 Device Functional Modes.....	13
5.3 Recommended Operating Conditions.....	4	7 Applications and Implementation	15
5.4 Thermal Information.....	5	7.1 Application Information.....	15
5.5 Supply Current.....	5	7.2 Typical Applications.....	15
5.6 Internal 1.8V LDO (REG18).....	5	7.3 Power Supply Recommendations.....	18
5.7 I/O (PULS, INT).....	5	7.4 Layout.....	18
5.8 Chip Enable (CE).....	5	8 Device and Documentation Support	20
5.9 Internal Temperature Sensor.....	6	8.1 Device Support.....	20
5.10 NTC Thermistor Measurement Support.....	6	8.2 Documentation Support.....	20
5.11 Coulomb Counter (CC).....	6	8.3 Receiving Notification of Documentation Updates.....	20
5.12 Analog Digital Converter (ADC).....	6	8.4 Support Resources.....	20
5.13 Internal Oscillator Specifications.....	7	8.5 Trademarks.....	20
5.14 Voltage Reference1 (REF1).....	7	8.6 Electrostatic Discharge Caution.....	20
5.15 Voltage Reference2 (REF2).....	7	8.7 Glossary.....	20
5.16 Flash Memory.....	7	9 Revision History	20
5.17 I ² C I/O.....	7	10 Mechanical, Packaging, and Orderable Information	21
5.18 I ² C Timing — 100kHz.....	8		
5.19 I ² C Timing — 400kHz.....	8		

4 Pin Configuration and Functions

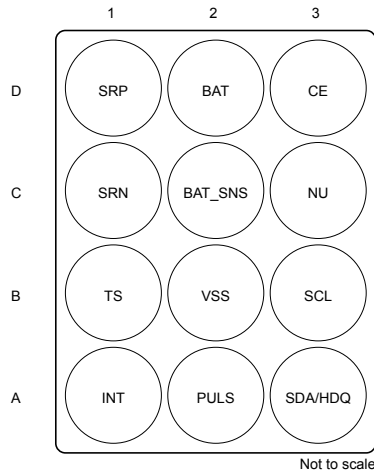

Figure 4-1. Pin Diagram

Table 4-1. Pin Functions

PIN		TYPE ⁽¹⁾	DESCRIPTION
NAME	NO.		
BAT	D2	P	Battery voltage measurement input. Kelvin battery sense connection to BAT_SNS. Connect a capacitor (1 μ F) between BAT and VSS. Place the capacitor close to the gauge.
CE	D3	I	Active-high chip enable
BAT_SNS	C2	AI	Battery sense
INT	A1	O	Interrupt for voltage, temperature, and state of charge (programmable active high or low)
PULS	A2	O	Programmable pulse width with active-high or -low option
TS	B1	AI	Temperature input for ADC
NU	C3	NC	Makes no external connection
SCL	B3	I/O	Serial clock for I ² C interface that requires an external pullup when used. It can be left floating if unused.
SDA/HDQ	A3	I/O	Serial data for I ² C interface and one-wire interface for HDQ (selectable) that requires an external pullup when used. It can be left floating if unused.
SRP	D1	I	Analog input pin connected to the internal coulomb counter peripheral for integrating a small voltage between SRP (positive side) and SRN
SRN	C1	I	Analog input pin connected to the internal coulomb counter peripheral for integrating a small voltage between SRP (positive side) and SRN
VSS	B2	P	Device ground

(1) P = Power Connection, O = Digital Output, AI = Analog Input, I = Digital Input, I/O = Digital Input/Output, NU = Not Used

5 Specifications

5.1 Absolute Maximum Ratings

Over operating free-air temperature range (unless otherwise noted)⁽¹⁾

		MIN	MAX	UNIT
Input Voltage	BAT	-0.3	6	V
	INT, PULS, CE	-0.3	6	V
	SRP, SRN, BAT_SNS	-0.3	$V_{BAT} + 0.3$	V
	TS	-0.3	2.1	V
	SCL, SDA/HDQ	-0.3	6	V
Operating ambient temperature, T_A		-40	85	°C
Operating junction temperature, T_J		-40	125	°C
Storage temperature, T_{stg}		-65	150	°C

- (1) Operation outside the Absolute Maximum Ratings may cause permanent device damage. Absolute Maximum Ratings do not imply functional operation of the device at these or any other conditions beyond those listed under Recommended Operating Conditions. If outside the Recommended Operating Conditions but within the Absolute Maximum Ratings, the device may not be fully functional, and this may affect device reliability, functionality, performance, and shorten the device lifetime.

5.2 ESD Ratings

		VALUE	UNIT
$V_{(ESD)}$ Electrostatic discharge	Human-body model (HBM) on all pins, per ANSI/ESDA/ JEDEC JS-001 ⁽¹⁾	±1500	V
	Charged-device model (CDM) on all pins, per ANSI/ESDA/ JEDEC JS-002 ⁽²⁾	±500	

- (1) JEDEC document JEP155 states that 500V HBM enables safe manufacturing with a standard ESD control process.

- (2) JEDEC document JEP157 states that 250V CDM enables safe manufacturing with a standard ESD control process.

5.3 Recommended Operating Conditions

Unless otherwise noted, characteristics noted under conditions of $T_A = -40^{\circ}\text{C}$ to 85°C

			MIN	NOM	MAX	UNIT
V_{BAT}	Supply voltage	No operating restrictions	2.0		5.5	V
C_{BAT}	External capacitor from BAT to VSS		1			μF
V_{TS}	Temperature sense		0		1.8	V
$V_{PULS}, V_{INT}, V_{CE}$	Input and output pins		0		V_{BAT}	V
$V_{SCL}, V_{SDA/HDQ}$	Communication pins		0		V_{BAT}	V

5.4 Thermal Information

Over-operating free-air temperature range (unless otherwise noted)

THERMAL METRIC ⁽¹⁾		BQ27Z561-R2	UNIT
		DSBGA (YPH)	
		(12 PINS)	
R _{θJA}	Junction-to-ambient thermal resistance	64.1	°C/W
R _{θJC(top)}	Junction-to-case (top) thermal resistance	59.8	
R _{θJB}	Junction-to-board thermal resistance	52.7	
Ψ _{JT}	Junction-to-top characterization parameter	0.3	
Ψ _{JB}	Junction-to-board characterization parameter	28.3	
R _{θJC(bot)}	Junction-to-case (bottom) thermal resistance	2.4	

(1) For more information about traditional and new thermal metrics, see the [Semiconductor and IC Package Thermal Metrics application note](#).

5.5 Supply Current

Unless otherwise noted, characteristics noted under conditions of T_A = –40°C to 85°C

PARAMETER	TEST CONDITIONS	MIN	TYP	MAX	UNIT
I _{NORMAL}	Standard operating conditions		60		μA
I _{SLEEP}	Sense resistor current below SLEEP mode threshold		11		μA
I _{DEEPSLEEP}	Sense resistor current below DEEP SLEEP mode threshold		9		μA
I _{HIBERNATE}	CE = V _{IH} , OFF state with ability to wake from valid communication		3		μA
I _{OFF}	CE = V _{IL}		0.5		μA

5.6 Internal 1.8V LDO (REG18)

Unless otherwise noted, characteristics noted under conditions of T_A = –40°C to 85°C

PARAMETER	TEST CONDITIONS	MIN	TYP	MAX	UNIT
V _{REG18}	Regulator output voltage	1.6	1.8	2.0	V
V _{PORth}	POR threshold	Rising threshold		1.7	V
V _{PORhy}	POR hysteresis		0.1		V

5.7 I/O (PULS, INT)

Unless otherwise noted, characteristics noted under conditions of T_A = –40°C to 85°C

PARAMETER	TEST CONDITIONS	MIN	TYP	MAX	UNIT
V _{IH}	High-level input voltage	V _{REG18} = 1.8V	1.15		V
V _{IL}	Low-level input voltage low	V _{REG18} = 1.8V		0.50	V
V _{OL}	Output voltage low	V _{REG18} = 1.8V, I _{OL} = 1mA		0.4	V
C _I	Input capacitance		5		pF
I _{Ikg}	Input leakage current			1	μA

5.8 Chip Enable (CE)

Unless otherwise noted, characteristics noted under conditions of T_A = –40°C to 85°C

PARAMETER	TEST CONDITIONS	MIN	TYP	MAX	UNIT
V _{IH}	High-level input voltage (assured by design)	V _{REG18} = 1.8V	0.75 × V _{BAT}		V
V _{IL}	Low-level input voltage low (assured by design)	V _{REG18} = 1.8V		0.25 × V _{BAT}	V

5.9 Internal Temperature Sensor

Unless otherwise noted, characteristics noted under conditions of $T_A = -40^{\circ}\text{C}$ to 85°C

PARAMETER		TEST CONDITIONS	MIN	TYP	MAX	UNIT
$V_{(\text{TEMP})}$	Internal temperature sensor voltage drift	V_{TEMP}	1.65	1.73	1.8	mV/ $^{\circ}\text{C}$
		$V_{\text{TEMP}} - V_{\text{TEMPN}}$ (assured by design)	0.17	0.18	0.19	

5.10 NTC Thermistor Measurement Support

Unless otherwise noted, characteristics noted under conditions of $T_A = -40^{\circ}\text{C}$ to 85°C

PARAMETER		TEST CONDITIONS	MIN	TYP	MAX	UNIT
$R_{\text{NTRC(PU)}}$	Internal pullup resistance		14.4	18	21.6	k Ω
$R_{\text{NTC(DRIFT)}}$	Resistance drift over temperature		-250	-120	0	PPM/ $^{\circ}\text{C}$

5.11 Coulomb Counter (CC)

Unless otherwise noted, characteristics noted under conditions of $T_A = -40^{\circ}\text{C}$ to 85°C

PARAMETER		TEST CONDITIONS	MIN	TYP	MAX	UNIT
$V_{(\text{CC_IN})}$	Differential input voltage range		-0.1		0.1	V
$t_{(\text{CC_CONV})}$	Conversion time	Single conversion		1000		ms
	Effective resolution	1LSB		3.8		μV
	Integral nonlinearity	16-bit, best fit over input voltage range	-22.3	5.2	+22.3	LSB
	Differential nonlinearity	16-bit, no missing codes		1.5		LSB
	Offset error	16-bit post calibration	-2.6	1.3	+2.6	LSB
	Offset error drift	15-bit + sign, post calibration		0.04	0.07	LSB/ $^{\circ}\text{C}$
	Gain error	15-bit + sign, over input voltage range	-492	131	+492	LSB
	Gain error drift	15-bit + sign, over input voltage range		4.3	9.8	LSB/ $^{\circ}\text{C}$
	Effective input resistance		7			M Ω

5.12 Analog Digital Converter (ADC)

Unless otherwise noted, characteristics noted under conditions of $T_A = -40^{\circ}\text{C}$ to 85°C

PARAMETER		TEST CONDITIONS	MIN	TYP	MAX	UNIT
$V_{\text{ADC_TS_GPIO}}$	Input voltage range	$V_{\text{FS}} = V_{\text{REF2}}$	-0.2		1.0	V
		$V_{\text{FS}} = V_{\text{REG18}} \times 2$	-0.2		1.44	V
$V_{\text{BAT_MODE}}$	Battery input voltage		-0.2		5.5	V
	Integral nonlinearity	16-bit, best fit, -0.1V to $0.8 \times V_{\text{REF2}}$	-8.4		+8.4	LSB
	Differential nonlinearity	16-bit, no missing codes		1.5		LSB
	Offset error	16-bit post calibration ⁽¹⁾ , $V_{\text{FS}} = V_{\text{REF2}}$	-4.2	1.8	+4.2	LSB
	Offset error drift	16-bit post calibration ⁽¹⁾ , $V_{\text{FS}} = V_{\text{REF2}}$		0.02	0.1	LSB/ $^{\circ}\text{C}$
	Gain Error	16-bit, -0.1 to $0.8 \times V_{\text{FS}}$	-492	131	+492	LSB
	Gain error drift	16-bit, -0.1 to $0.8 \times V_{\text{FS}}$		2	4.5	LSB/ $^{\circ}\text{C}$
	Effective input resistance		8			M Ω
$t_{(\text{ADC_CONV})}$	Conversion time			11.7		ms
	Effective resolution		14	15		bits

(1) Factory calibration

5.13 Internal Oscillator Specifications

Unless otherwise noted, characteristics noted under conditions of $T_A = -40^\circ\text{C}$ to 85°C

PARAMETER	TEST CONDITIONS	MIN	TYP	MAX	UNIT
High Frequency Oscillator (HFO)					
f_{HFO}	Operating frequency		16.78		MHz
f_{HFO}	HFO frequency drift	$T_A = -20^\circ\text{C}$ to 70°C	-2.5%	2.5%	
		$T_A = -40^\circ\text{C}$ to 85°C	-3.5	3.5	
t_{HFOSTART}	HFO start-up time	$T_A = -40^\circ\text{C}$ to 85°C , oscillator frequency within $\pm 3\%$ of nominal frequency or a power-on reset			4 ms
Low Frequency Oscillator (LFO)					
f_{LFO}	Operating frequency		65.536		kHz
$f_{\text{LFO(ERR)}}$	Frequency error	$T_A = -40^\circ\text{C}$ to 85°C	-2.5%	+2.5%	

5.14 Voltage Reference1 (REF1)

Unless otherwise noted, characteristics noted under conditions of $T_A = -40^\circ\text{C}$ to 85°C

PARAMETER	TEST CONDITIONS	MIN	TYP	MAX	UNIT
V_{REF1}	Internal reference voltage ⁽¹⁾	1.195	1.21	1.227	V
$V_{\text{REF1_DRIFT}}$	Internal reference voltage drift	$T_A = -40^\circ\text{C}$ to 85°C			-80 +80 PPM/°C

(1) Used for CC and LDO

5.15 Voltage Reference2 (REF2)

Unless otherwise noted, characteristics noted under conditions of $T_A = -40^\circ\text{C}$ to 85°C

PARAMETER	TEST CONDITIONS	MIN	TYP	MAX	UNIT
V_{REF2}	Internal reference voltage ⁽¹⁾	1.2	1.21	1.22	V
$V_{\text{REF2_DRIFT}}$	Internal reference voltage drift	$T_A = -40^\circ\text{C}$ to 85°C			-20 20 PPM/°C

(1) Used for ADC

5.16 Flash Memory

Unless otherwise noted, characteristics noted under conditions of $T_A = -40^\circ\text{C}$ to 85°C

PARAMETER	TEST CONDITIONS	MIN	TYP	MAX	UNIT
	Data retention	10	100		Years
	Flash programming write cycles	Data Flash	20000		Cycles
		Instruction Flash	1000		Cycles
$t_{\text{(ROWPROG)}}$	Row programming time			40	μs
$t_{\text{(MASSERASE)}}$	Mass-erase time	$T_A = -40^\circ\text{C}$ to 85°C			40 ms
$t_{\text{(PAGEERASE)}}$	Page-erase time	$T_A = -40^\circ\text{C}$ to 85°C			40 ms
$I_{\text{FLASHREAD}}$	Flash read current	$T_A = -40^\circ\text{C}$ to 85°C			1 mA
$I_{\text{FLASHWRTIE}}$	Flash write current	$T_A = -40^\circ\text{C}$ to 85°C			5 mA
$I_{\text{FLASHERASE}}$	Flash erase current	$T_A = -40^\circ\text{C}$ to 85°C			15 mA

5.17 I²C I/O

Unless otherwise noted, characteristics noted under conditions of $T_A = -40^\circ\text{C}$ to 85°C

PARAMETER	TEST CONDITIONS	MIN	TYP	MAX	UNIT
V_{IH}	High-level input voltage	SCL, SDA/HDQ, $V_{\text{REG18}} = 1.8\text{V}$			1.26 V
V_{IL}	Low-level input voltage low	$V_{\text{REG18}} = 1.8\text{V}$			0.54 V

Unless otherwise noted, characteristics noted under conditions of $T_A = -40^{\circ}\text{C}$ to 85°C

PARAMETER		TEST CONDITIONS	MIN	TYP	MAX	UNIT
V_{OL}	Low-level output voltage	$I_{OL} = 1\text{mA}$, $V_{REG18} = 1.8\text{V}$			0.36	V
C_I	Input capacitance				10	pF
I_{lkg}	Input leakage current			1		μA

5.18 I²C Timing — 100kHz

PARAMETER		TEST CONDITIONS	MIN	NOM	MAX	UNIT
f_{SCL}	Clock operating frequency	SCL duty cycle = 50%			100	kHz
$t_{HD:STA}$	Start condition hold time		4.0			μs
t_{LOW}	Low period of the SCL Clock		4.7			μs
t_{HIGH}	High period of the SCL Clock		4.0			μs
$t_{SU:STA}$	Setup repeated START		4.7			μs
$t_{HD:DAT}$	Data hold time (SDA input)		0			ns
$t_{SU:DAT}$	Data setup time (SDA input)		250			ns
t_r	Clock rise time	10% to 90%			1000	ns
t_f	Clock fall time	90% to 10%			300	ns
$t_{SU:STO}$	Setup time STOP condition		4.0			μs
t_{BUF}	Bus free time STOP to START		4.7			μs

5.19 I²C Timing — 400kHz

PARAMETER		TEST CONDITIONS	MIN	NOM	MAX	UNIT
f_{SCL}	Clock operating frequency	SCL duty cycle = 50%			400	kHz
$t_{HD:STA}$	START condition hold time		0.6			μs
t_{LOW}	Low period of the SCL Clock		1.3			μs
t_{HIGH}	High period of the SCL Clock		600			ns
$t_{SU:STA}$	Setup repeated START		600			ns
$t_{HD:DAT}$	Data hold time (SDA input)		0			ns
$t_{SU:DAT}$	Data setup time (SDA input)		100			ns
t_r	Clock rise time	10% to 90%			300	ns
t_f	Clock fall time	90% to 10%			300	ns
$t_{SU:STO}$	Setup time STOP condition		0.6			μs
t_{BUF}	Bus free time STOP to START		1.3			μs

5.20 HDQ Timing

PARAMETER		TEST CONDITIONS	MIN	NOM	MAX	UNIT
t_B	Break time		190			μs
t_{BR}	Break recovery time		40			μs
t_{HW1}	Host write 1 time	Host drives HDQ	0.5		50	μs
t_{HW0}	Host write 0 time	Host drives HDQ	86		145	μs
t_{CYCH}	Cycle time, host to device	Device drives HDQ	190			μs
t_{CYCD}	Cycle time, device to Host	Device drives HDQ	190	205	250	μs
t_{DW1}	Device write 1 time	Device drives HDQ	32		50	μs
t_{DW0}	Device write 0 time	Device drives HDQ	80		145	μs
t_{RSPS}	Device response time	Device drives HDQ	190		950	μs

PARAMETER	TEST CONDITIONS	MIN	NOM	MAX	UNIT
t_{TRND}	Host turn around time	Host drives HDQ after device drives HDQ	250		μ s
t_{RISE}	HDQ line rising time to logic 1			1.8	μ s
t_{RST}	HDQ Reset	Host drives HDQ low before device reset	2.2		s

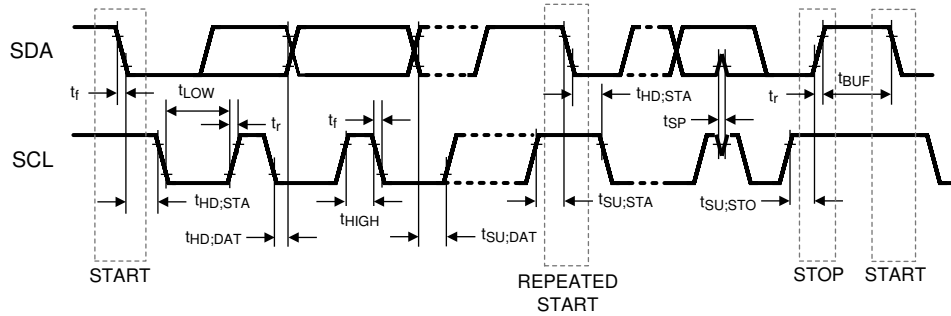
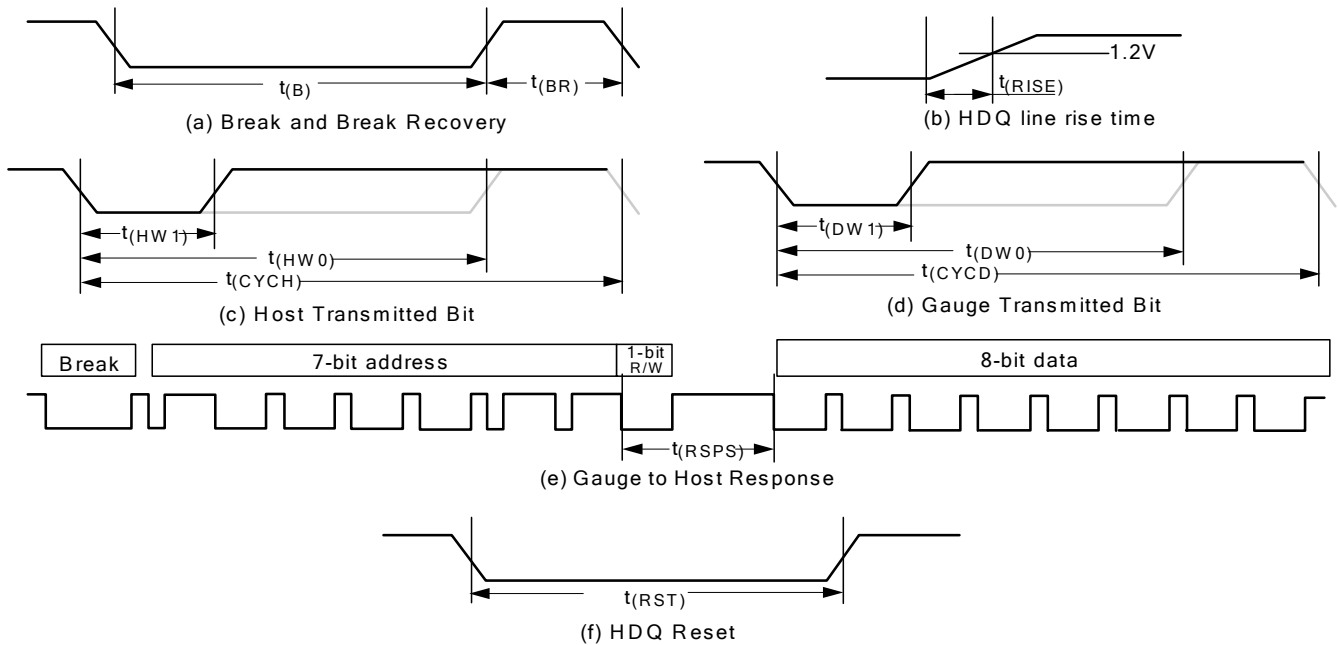

Figure 5-1. I²C Timing



- a. HDQ Breaking
- b. Rise time of HDQ line
- c. HDQ Host to fuel gauge communication
- d. Fuel gauge to Host communication
- e. Fuel gauge to Host response format
- f. HDQ Host to fuel gauge

Figure 5-2. HDQ Timing

5.21 Typical Characteristics

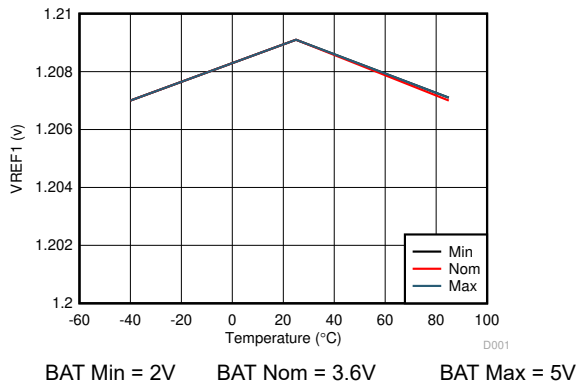

Figure 5-3. REF1 Voltage Versus Battery and Temperature

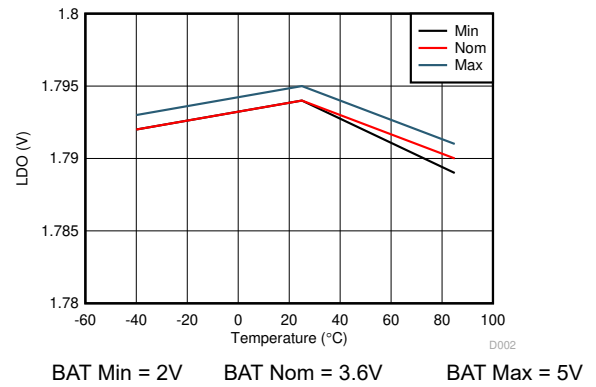

Figure 5-4. LDO Voltage Versus Battery and Temperature

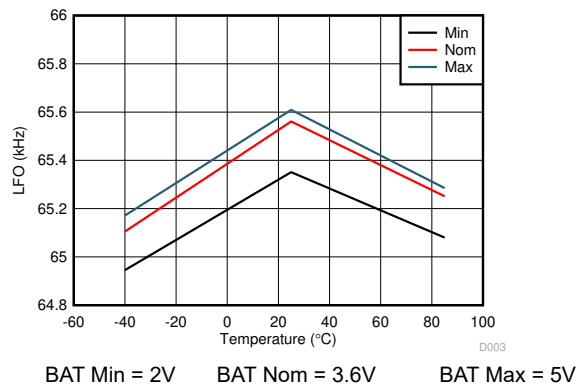

Figure 5-5. LFO Frequency Versus Battery and Temperature

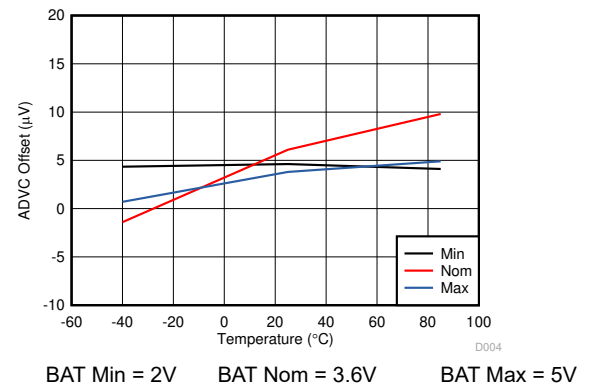

Figure 5-6. ADVC Offset Voltage Versus Battery and Temperature

6 Detailed Description

6.1 Overview

The BQ27Z561-R2 gas gauge is a fully integrated battery manager that employs flash-based firmware to provide a complete solution for battery-stack architectures composed of 1-series cells. The BQ27Z561-R2 device interfaces with a host system through an I²C or HDQ protocol. High-performance, integrated analog peripherals enable support for a sense resistor down to 1mΩ, and simultaneous current and voltage data conversion for instant power calculations. The following sections detail all of the major component blocks included as part of the BQ27Z561-R2 device.

6.2 Functional Block Diagram

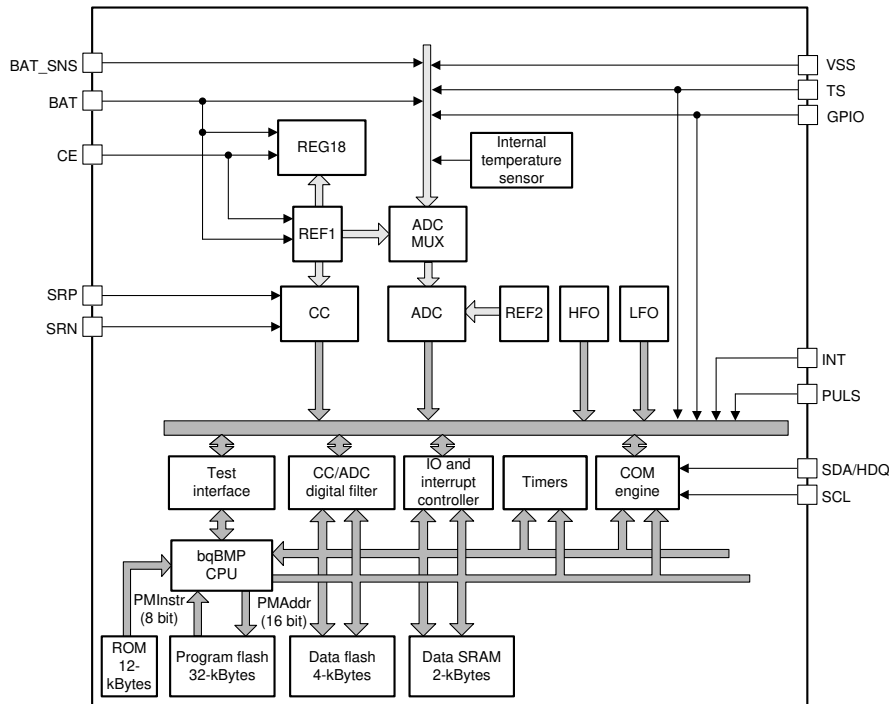

6.3 Feature Description

6.3.1 BQ27Z561-R2 Processor

The BQ27Z561-R2 device uses a custom TI-proprietary processor design that features a Harvard architecture and operates at frequencies up to 4.2MHz. Using an adaptive, three-stage instruction pipeline, the BQ27Z561-R2 processor supports variable instruction lengths of 8, 16, or 24 bits.

6.3.2 Battery Parameter Measurements

The BQ27Z561-R2 device measures cell voltage and current simultaneously, and also measures temperature to calculate the information related to the following:

- Remaining capacity
- Full charge capacity
- State-of-health
- Other gauging parameters

6.3.2.1 Coulomb Counter (CC)

The first ADC is an integrating analog-to-digital converter designed specifically for tracking charge and discharge activity, or coulomb counting, of a rechargeable battery. The ADC features a single-channel differential input that converts the voltage difference across a sense resistor between the SRP and SRN pins with a resolution of 3.74μV.

6.3.2.2 CC Digital Filter

The CC digital filter generates a 16-bit conversion value from the delta-sigma CC front end. The FIR filter uses the HFO clock output. New conversions are available every 1s.

6.3.2.3 ADC Multiplexer

The ADC multiplexer provides selectable connections to the following:

- External pins BAT, BAT_SNS, and TS
- Internal temperature sensor
- Internal reference voltages
- Internal 1.8V regulator
- VSS ground reference input

In addition, the multiplexer can independently enable the TS input connection to the internal thermistor biasing circuitry, and enables the user to short the multiplexer inputs for test and calibration purposes.

6.3.2.4 Analog-to-Digital Converter (ADC)

The second ADC is a 16-bit delta-sigma converter designed for general-purpose measurements. The ADC automatically scales the input voltage range during sampling based on channel selection. The converter resolution is a function of the full-scale range and number of bits, yielding a 38 μ V resolution.

6.3.2.5 Internal Temperature Sensor

An internal temperature sensor is available on the BQ27Z561-R2 device to reduce the cost, power, and size of the external components necessary to measure temperature. The sensor is available for connection to the ADC using the multiplexer, and is appropriate for quickly determining pack temperature under a variety of operating conditions.

6.3.2.6 External Temperature Sensor Support

The TS input is enabled with an internal 18k Ω (typical) linearization pullup resistor to support the use of a 10k Ω (25 $^{\circ}$ C) NTC external thermistor, such as the Semitec 103AT-2. Connect the NTC thermistor between VSS and the individual TS pin. The ADC takes the analog measurement through the input multiplexer. If using a different type of thermistor, consider changing configurations.

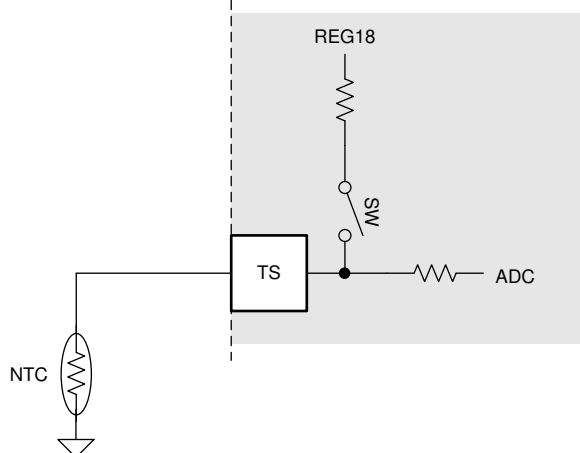

Figure 6-1. External Thermistor Biasing

6.3.3 Power Supply Control

The BQ27Z561-R2 device uses the BAT pin as for a power source. BAT powers the internal voltage sources that supply references for the device. BAT_SNS is a noncurrent carrying path and is used at the Kelvin reference for BAT.

6.3.4 Bus Communication Interface

The BQ27Z561-R2 device has an I²C bus communication interface. Alternatively, the BQ27Z561-R2 can be configured to communicate through the HDQ pin (shared with SDA).

Note

Once the device is switched to the HDQ protocol, it is not reversible.

6.3.5 Low Frequency Oscillator

The BQ27Z561-R2 device includes a low frequency oscillator (LFO) running at 65.536kHz.

6.3.6 High Frequency Oscillator

The BQ27Z561-R2 includes a high frequency oscillator (HFO) running at 16.78MHz. The HFO is frequency locked to the LFO output and scaled down to 8.388MHz with a 50% duty cycle.

6.3.7 1.8V Low Dropout Regulator

The BQ27Z561-R2 device contains an integrated capacitor-less 1.8V LDO (REG18) that provides regulated supply voltage for the device CPU and internal digital logic.

6.3.8 Internal Voltage References

The BQ27Z561-R2 device provides two internal voltage references. REF1 is used by REG18, oscillators, and CC. REF2 is used by the ADC.

6.3.9 Gas Gauging

This device uses the Impedance Track™ technology to measure and determine the available charge in battery cells. See the [Theory and Implementation of Impedance Track Battery Fuel-Gauging Algorithm application note](#) for further details.

6.3.10 Charge Control Features

This device supports charge control features, such as:

- Reports charging voltage and charging current based on the active temperature range—JEITA temperature ranges T1, T2, T3, T4, T5, and T6
- Provides more complex charging profiles, including sub-ranges within a standard temperature range
- Reports the appropriate charging current required for constant current charging, and the appropriate charging voltage needed for constant voltage charging to a smart charger, using the bus communication interface
- Compensates the charging profile based on the value of *RelativeStateOfCharge()*
- Selects the chemical state-of-charge of each battery cell using the Impedance Track method
- Reports charging faults and indicates charge status via charge and discharge alarms

6.3.11 Authentication

This device supports security with the following features, which can be enabled if desired:

- Authentication by the host using the SHA-256 method
- The gas gauge requires SHA-256 authentication before the device can be unsealed or allow full access.

6.4 Device Functional Modes

This device supports five modes, but the current consumption varies, based on firmware control of certain functions and modes of operation:

- **NORMAL mode:** In this mode, the device performs measurements, calculations, protections, and data updates in 250ms intervals. Between intervals, the device operates in a reduced power stage to minimize total average current consumption.

- **SLEEP mode:** In this mode, the device performs measurements, calculations, and data updates in adjustable time intervals. Between intervals, the device operates in a reduced power stage to minimize total average current consumption.
- **DEEP SLEEP mode:** In this mode, the current reduces slightly while current and voltage are still measured periodically, with a user-defined time between reads.
- **HIBERNATE mode:** In this mode, the device completely disables with CE remaining high. This mode is exited upon two valid communications within a specified time window.
- **OFF mode:** The device is completely disabled by pulling CE low. CE disables the internal voltage rail. All nonvolatile memory is unprotected.

6.4.1 Lifetime Logging Features

The device supports data logging of several key parameters for warranty and analysis:

- Maximum and minimum cell temperature
- Maximum current in CHARGE or DISCHARGE mode
- Maximum and minimum cell voltages
- Total run time (the data is stored with a resolution of two hours)
- Time spent different temperature ranges (the data is stored with a resolution of two hours)

6.4.2 Configuration

The device supports accurate data measurements and data logging of several key parameters.

6.4.2.1 Coulomb Counting

The device uses an integrating delta-sigma analog-to-digital converter (ADC) for current measurement. The ADC measures charge and discharge flow of the battery by measuring the voltage across a very small external sense resistor. The integrating ADC measures a bipolar signal from a range of -100mV to 100mV , with a positive value when $V_{(\text{SRP})} - V_{(\text{SRN})}$, indicating charge current and a negative value indicating discharge current.

The current measurement is performed by measuring the voltage drop across the external sense resistor, which can be as low as $1\text{m}\Omega$, and the polarity of the differential voltage determines if the cell is in the CHARGE or DISCHARGE mode.

6.4.2.2 Cell Voltage Measurements

The BQ27Z561-R2 gas gauge measures the cell voltage at 1s intervals using the ADC. The measured value internally scales for the ADC and calibrates to reduce any errors due to offsets. The data is also used calculate the impedance of the cell for Impedance Track gas gauging.

6.4.2.3 Auto Calibration

The auto-calibration feature helps to cancel any voltage offset across the SRP and SRN pins for accurate measurement of the cell voltage, charge and discharge current, and thermistor temperature. The auto-calibration is performed when there is no communication activity for a minimum of 5s on the bus lines.

6.4.2.4 Temperature Measurements

This device has an internal sensor for on-die temperature measurements, and the ability to support an external temperature measurement via the external NTC on the TS pin. These two measurements are individually enabled and configured.

7 Applications and Implementation

Note

Information in the following applications sections is not part of the TI component specification, and TI does not warrant its accuracy or completeness. TI's customers are responsible for determining suitability of components for their purposes, as well as validating and testing their design implementation to confirm system functionality.

7.1 Application Information

Use the BQ27Z561-R2 gas gauge with a 1-series Li-ion or Li-polymer battery pack. To implement and design a comprehensive set of parameters for a specific battery pack, use the Battery Management Studio (BQSTUDIO), a PC-based graphical user-interface tool. The firmware installed in the product has default values, which are summarized in the *BQ27Z561-R2 Technical Reference Manual*. Using the BQSTUDIO tool, change the default values to cater to specific application requirements during development once the system parameters, such as enable and disable of certain features for operation, cell configuration, chemistry that best matches the cell used, and more are known. The final flash image is extracted after configuration and testing are complete. The final flash image is used for mass production and is referred to as the *golden image*.

7.2 Typical Applications

The following is an example BQ27Z561-R2 application schematic for a single-cell battery pack.

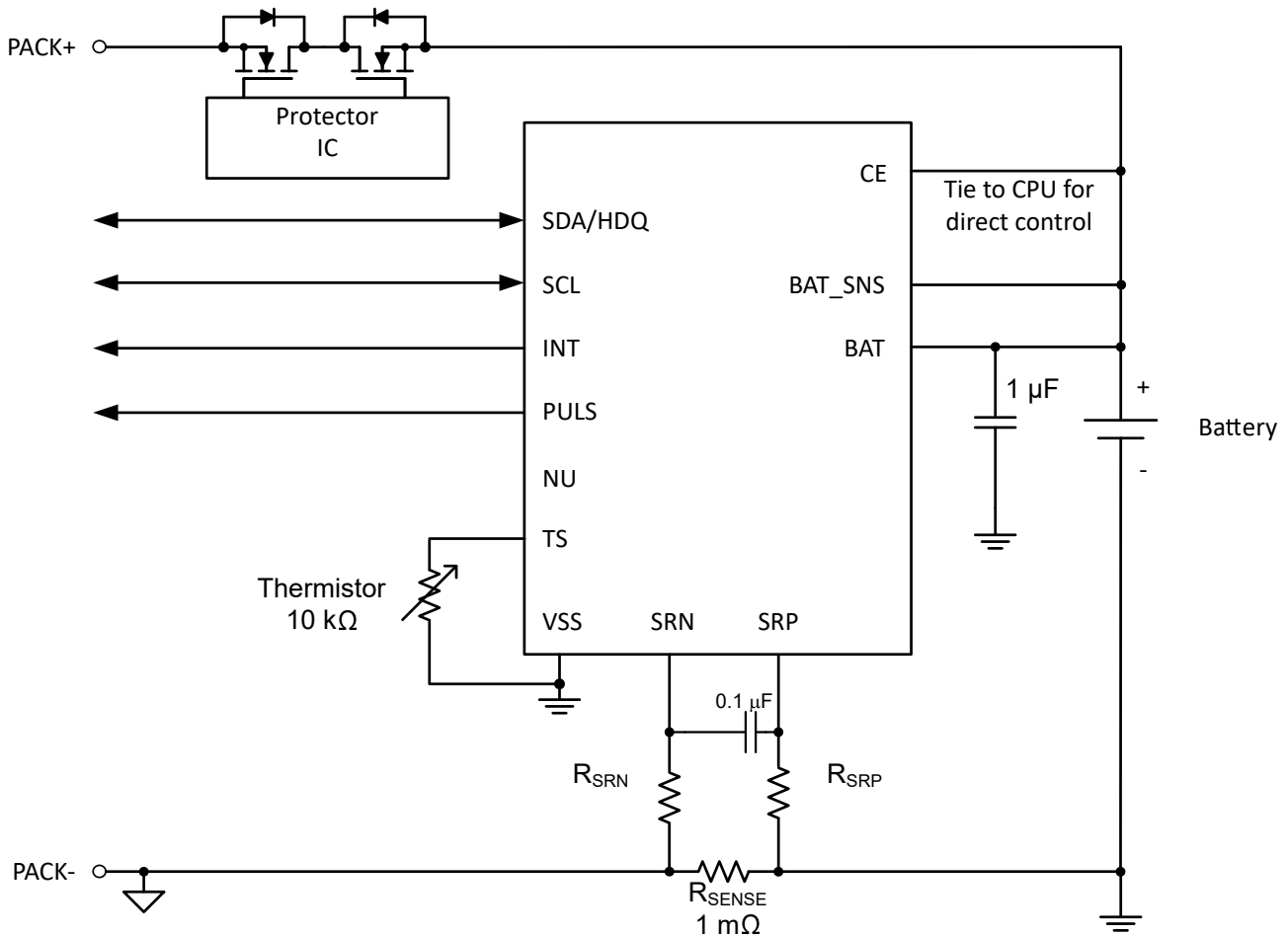

Figure 7-1. BQ27Z561-R1 Typical Implementation with Low-side Current Sensing

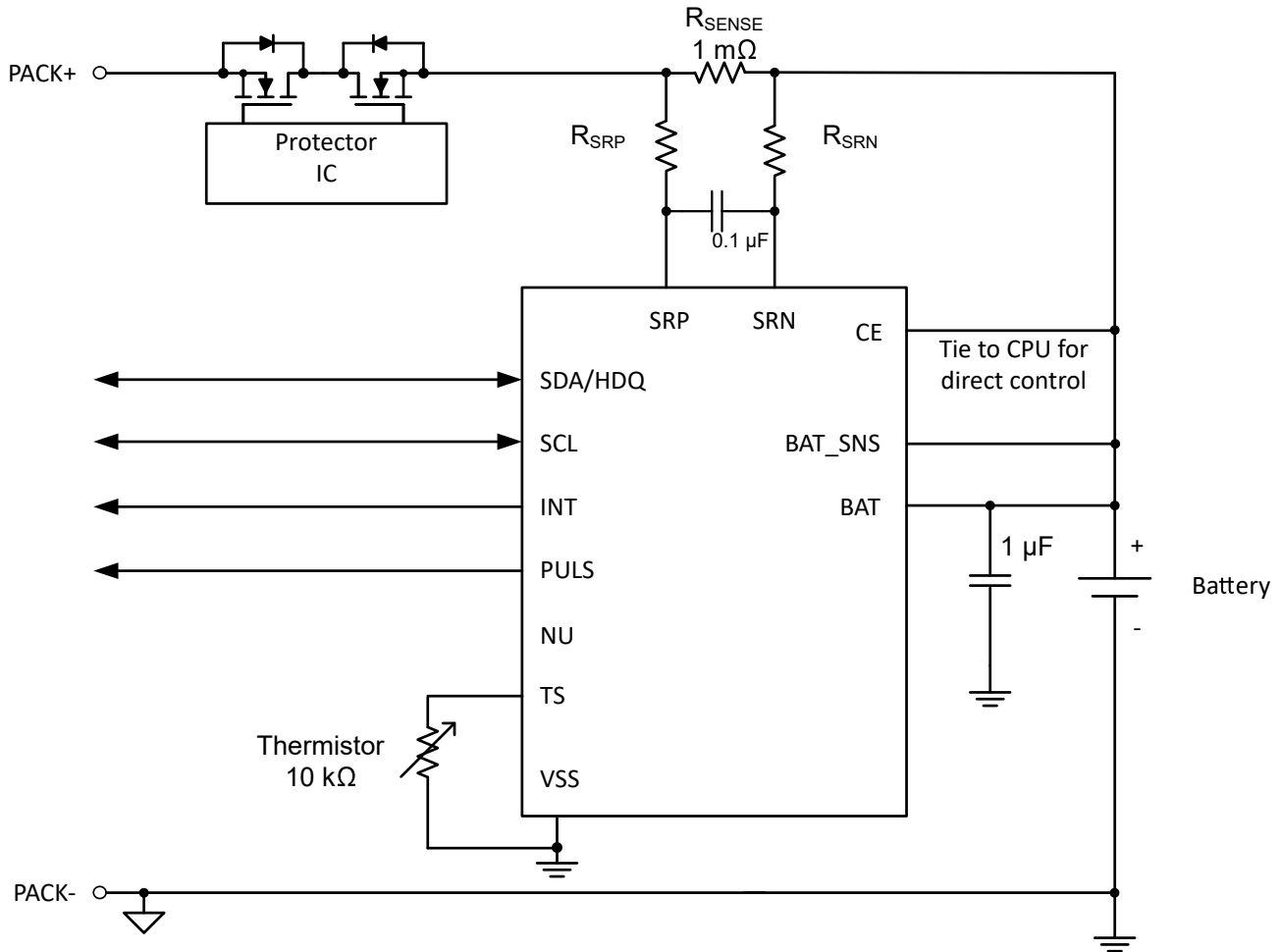

Figure 7-2. BQ27Z561-R1 Typical Implementation with High-side Current Sensing

7.2.1 Design Requirements (Default)

DESIGN PARAMETER	EXAMPLE
Cell configuration	1s1p (1 series with 1 parallel)
Design capacity	5300mAh
Device chemistry	Li-ion
Design voltage	4000mV
Cell low voltage	2500mV

7.2.2 Detailed Design Procedure

7.2.2.1 Changing Design Parameters

For the firmware settings needed for the design requirements, refer to the [BQ27Z561-R2 Technical Reference Manual](#).

- To change design capacity, set the data flash value (in mAh) in the **Gas Gauging: Design: Design Capacity** register.
- To set device chemistry, go to the data flash **I²C Configuration: Data: Device Chemistry** . The BQSTUDIO software automatically populates the correct chemistry identification. This selection is derived from using the BQCHEM feature in the tools and choosing the option that matches the device chemistry from the list.
- To set the design voltage, go to **Gas Gauging: Design: Design Voltage** register.

- To set the Cell **Low Voltage** or clear the Cell **Low Voltage** , use **Settings: Configuration: Init Voltage Low Set** or **Clear** . This is used to set the cell voltage level that will set (clear) the [VOLT_LO] bit in the *Interrupt Status* register.
- To enable the internal temperature and the external temperature sensors: Set **Settings:Configuration: Temperature Enable** : Bit 0 (TSInt) = 1 for the internal sensor; set Bit 1 (TS1) = 1 for the external sensor.

7.2.3 Calibration Process

The calibration of current, voltage, and temperature readings is accessible by writing 0xF081 or 0xF082 to *ManufacturerAccess()*. A detailed procedure is included in the [BQ27Z561-R2 Technical Reference Manual](#) in the *Calibration* section. The description allows for calibration of cell voltage measurement offset, battery voltage, current calibration, coulomb counter offset, PCB offset, CC gain and capacity gain, and temperature measurement for both internal and external sensors.

7.2.4 Gauging Data Updates

When a battery pack enabled with the BQ27Z561-R2 gas gauge is cycled, the value of *FullChargeCapacity()* updates several times, including the onset of charge or discharge, charge termination, temperature delta, resistance updates during discharge, and relaxation. [Figure 7-3](#) shows actual battery voltage, load current, and *FullChargeCapacity()* when some of those updates occur during a single application cycle.

Update points from the plot include:

- Charge termination at 7900s
- Relaxation at 9900s
- Resistance update at 11500s

7.2.4.1 Application Curve

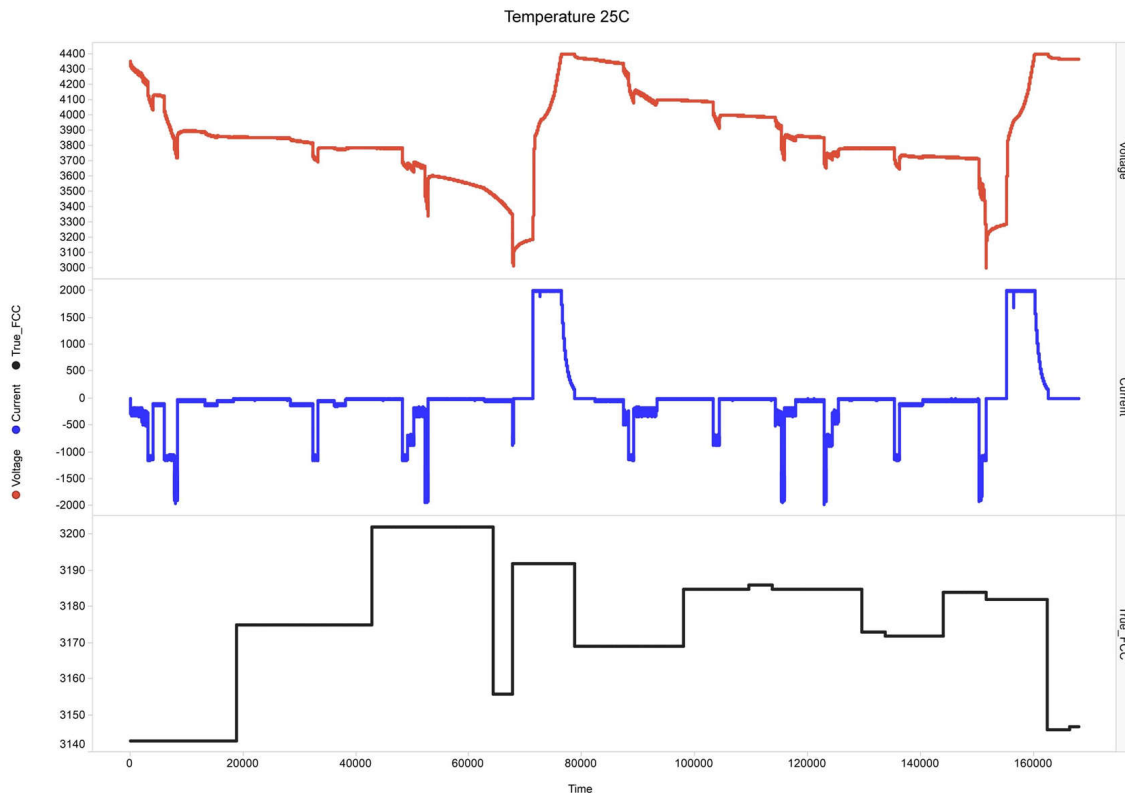

Figure 7-3. Full Charge Capacity Tracking (X-Axis Is Seconds)

7.3 Power Supply Recommendations

The only power supply is the BAT pin which connects to the positive terminal of the battery. The input voltage for the BAT pin has a minimum of 2V to a maximum of 5V.

7.4 Layout

7.4.1 Layout Guidelines

- The quality of the Kelvin connections at the sense resistor is critical. Verify that the sense resistor have a temperature coefficient no greater than 50ppm to minimize current measurement drift with temperature. Choose the value of the sense resistor to correspond to the available overcurrent and short-circuit ranges of the BQ27Z561-R2 gas gauge. Select the smallest value possible to minimize the negative voltage generated on the BQ27Z561-R2 VSS node during a short circuit. This pin has an absolute minimum of -0.3V . Use parallel resistors as long as good Kelvin sensing is established. The device is designed to support a $1\text{m}\Omega$ to $3\text{m}\Omega$ sense resistor.
- Directly tie the BAT_SNS to the positive connection of the battery. Verify that BAT_SNS does not share a path with the BAT pin.
- In reference to the gas gauge circuit the following features require attention for component placement and layout: differential low-pass filter and I²C communication.
- The BQ27Z561-R2 gas gauge uses an integrating delta-sigma ADC for current measurements. Add a 100Ω resistor from the sense resistor to the SRP and SRN inputs of the device. Place a $0.1\mu\text{F}$ filter capacitor across the SRP and SRN inputs. If required for a circuit, add $0.1\mu\text{F}$ filter capacitors for additional noise filtering for each sense input pin to ground. Place all filter components as close as possible to the device. Route the traces from the sense resistor in parallel to the filter circuit. Adding a ground plane around the filter network can provide additional noise immunity.
- The BQ27Z561-R2 has an internal LDO that is internally compensated and does not require an external decoupling capacitor.
- The I²C clock and data pins have integrated high-voltage ESD protection circuits; however, adding a Zener diode and series resistor provides more robust ESD performance. The I²C clock and data lines have an internal pulldown. When the gas gauge senses that both lines are low (such as during removal of the pack), the device performs auto-offset calibration and then goes into SLEEP mode to conserve power.

7.4.2 Layout Example

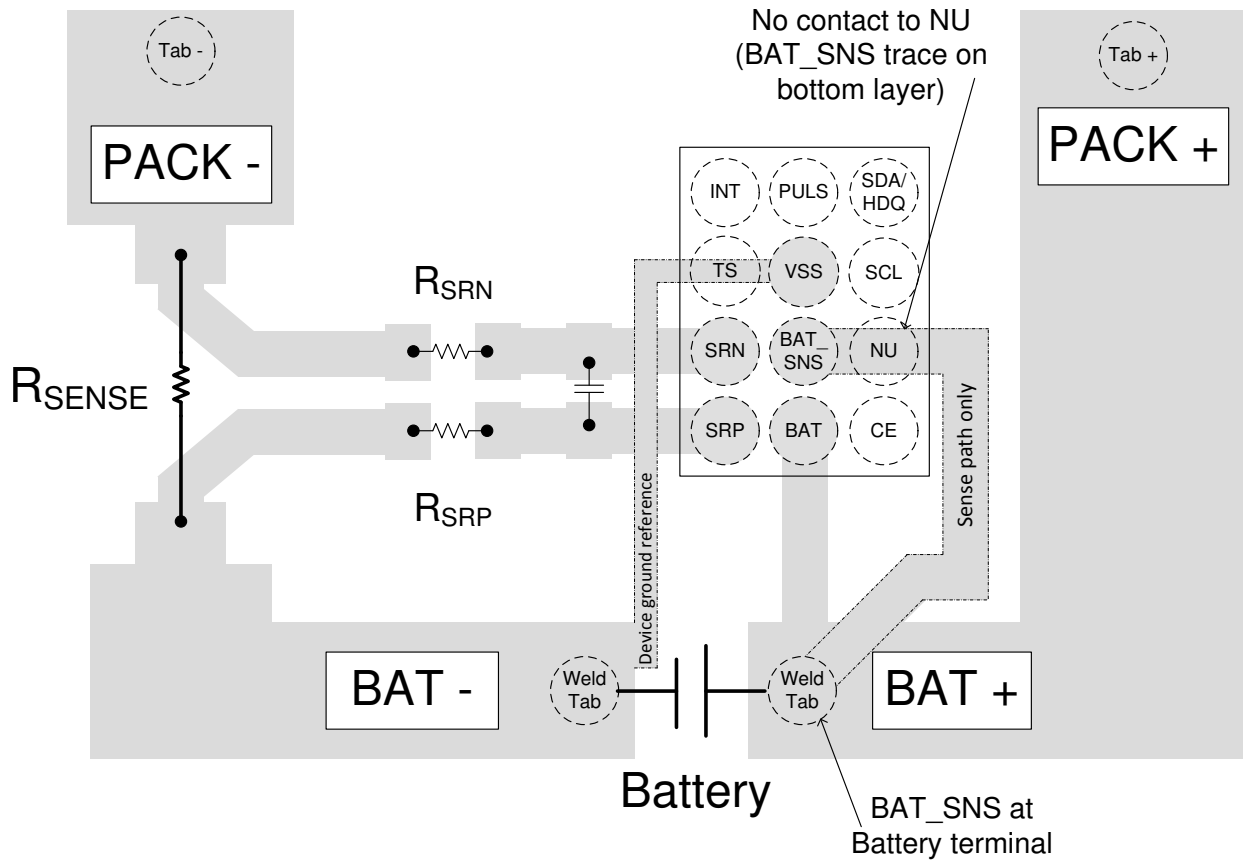

Figure 7-4. BQ27Z561-R2 Key Trace Board Layout

8 Device and Documentation Support

8.1 Device Support

8.1.1 Third-Party Products Disclaimer

TI'S PUBLICATION OF INFORMATION REGARDING THIRD-PARTY PRODUCTS OR SERVICES DOES NOT CONSTITUTE AN ENDORSEMENT REGARDING THE SUITABILITY OF SUCH PRODUCTS OR SERVICES OR A WARRANTY, REPRESENTATION OR ENDORSEMENT OF SUCH PRODUCTS OR SERVICES, EITHER ALONE OR IN COMBINATION WITH ANY TI PRODUCT OR SERVICE.

8.2 Documentation Support

8.2.1 Related Documentation

- Texas Instruments, [BQ27Z561-R2 Technical Reference Manual](#)
- Texas Instruments, [Theory and Implementation of Impedance Track Battery Fuel-Gauging Algorithm application note](#)
- Texas Instruments, [Semiconductor and IC Package Thermal Metrics application note](#)
- Texas Instruments, [BQSTUDIO software](#)

8.3 Receiving Notification of Documentation Updates

To receive notification of documentation updates, navigate to the device product folder on ti.com. In the upper right corner, click on **Alert me** to register and receive a weekly digest of any product information that has changed. For change details, review the revision history included in any revised document.

8.4 Support Resources

[TI E2E™ support forums](#) are an engineer's go-to source for fast, verified answers and design help — straight from the experts. Search existing answers or ask your own question to get the quick design help you need.

Linked content is provided "AS IS" by the respective contributors. They do not constitute TI specifications and do not necessarily reflect TI's views; see TI's [Terms of Use](#).

8.5 Trademarks

Impedance Track™ and TI E2E™ are trademarks of Texas Instruments.

All trademarks are the property of their respective owners.

8.6 Electrostatic Discharge Caution



This integrated circuit can be damaged by ESD. Texas Instruments recommends that all integrated circuits be handled with appropriate precautions. Failure to observe proper handling and installation procedures can cause damage.

ESD damage can range from subtle performance degradation to complete device failure. Precision integrated circuits may be more susceptible to damage because very small parametric changes could cause the device not to meet its published specifications.

8.7 Glossary

[TI Glossary](#) This glossary lists and explains terms, acronyms, and definitions.

9 Revision History

NOTE: Page numbers for previous revisions may differ from page numbers in the current version.

Changes from Revision B (November 2022) to Revision C (September 2025)	Page
• Updated the numbering format for tables, figures, and cross-references throughout the document.....	1

Changes from Revision A (November 2021) to Revision B (November 2022)	Page
• Removed the CE reference in this section; added a new, separate section for CE.....	5
• Added the <i>Chip Enable (CE)</i> section for the CE pin thresholds that are assured by design.....	5

10 Mechanical, Packaging, and Orderable Information

The following page includes mechanical, packaging, and orderable information. This information is the most current data available for the designated devices. This data is subject to change without notice and revision of this document. For browser-based versions of this data sheet, refer to the left-hand navigation.

PACKAGING INFORMATION

Orderable part number	Status (1)	Material type (2)	Package Pins	Package qty Carrier	RoHS (3)	Lead finish/ Ball material (4)	MSL rating/ Peak reflow (5)	Op temp (°C)	Part marking (6)
BQ27Z561YPHR-R2	Active	Production	DSBGA (YPH) 12	3000 LARGE T&R	Yes	SNAGCU	Level-1-260C-UNLIM	-40 to 85	Q27Z561R2
BQ27Z561YPHR-R2.A	Active	Production	DSBGA (YPH) 12	3000 LARGE T&R	Yes	SNAGCU	Level-1-260C-UNLIM	-40 to 85	Q27Z561R2
BQ27Z561YPHR-R2.B	Active	Production	DSBGA (YPH) 12	3000 LARGE T&R	Yes	SNAGCU	Level-1-260C-UNLIM	-40 to 85	Q27Z561R2

(1) **Status:** For more details on status, see our [product life cycle](#).

(2) **Material type:** When designated, preproduction parts are prototypes/experimental devices, and are not yet approved or released for full production. Testing and final process, including without limitation quality assurance, reliability performance testing, and/or process qualification, may not yet be complete, and this item is subject to further changes or possible discontinuation. If available for ordering, purchases will be subject to an additional waiver at checkout, and are intended for early internal evaluation purposes only. These items are sold without warranties of any kind.

(3) **RoHS values:** Yes, No, RoHS Exempt. See the [TI RoHS Statement](#) for additional information and value definition.

(4) **Lead finish/Ball material:** Parts may have multiple material finish options. Finish options are separated by a vertical ruled line. Lead finish/Ball material values may wrap to two lines if the finish value exceeds the maximum column width.

(5) **MSL rating/Peak reflow:** The moisture sensitivity level ratings and peak solder (reflow) temperatures. In the event that a part has multiple moisture sensitivity ratings, only the lowest level per JEDEC standards is shown. Refer to the shipping label for the actual reflow temperature that will be used to mount the part to the printed circuit board.

(6) **Part marking:** There may be an additional marking, which relates to the logo, the lot trace code information, or the environmental category of the part.

Multiple part markings will be inside parentheses. Only one part marking contained in parentheses and separated by a "-" will appear on a part. If a line is indented then it is a continuation of the previous line and the two combined represent the entire part marking for that device.

Important Information and Disclaimer: The information provided on this page represents TI's knowledge and belief as of the date that it is provided. TI bases its knowledge and belief on information provided by third parties, and makes no representation or warranty as to the accuracy of such information. Efforts are underway to better integrate information from third parties. TI has taken and continues to take reasonable steps to provide representative and accurate information but may not have conducted destructive testing or chemical analysis on incoming materials and chemicals. TI and TI suppliers consider certain information to be proprietary, and thus CAS numbers and other limited information may not be available for release.

In no event shall TI's liability arising out of such information exceed the total purchase price of the TI part(s) at issue in this document sold by TI to Customer on an annual basis.

TAPE AND REEL INFORMATION

QUADRANT ASSIGNMENTS FOR PIN 1 ORIENTATION IN TAPE



*All dimensions are nominal

Device	Package Type	Package Drawing	Pins	SPQ	Reel Diameter (mm)	Reel Width W1 (mm)	A0 (mm)	B0 (mm)	K0 (mm)	P1 (mm)	W (mm)	Pin1 Quadrant
BQ27Z561YPHR-R2	DSBGA	YPH	12	3000	180.0	8.4	1.83	2.2	0.53	4.0	8.0	Q1

TAPE AND REEL BOX DIMENSIONS

*All dimensions are nominal

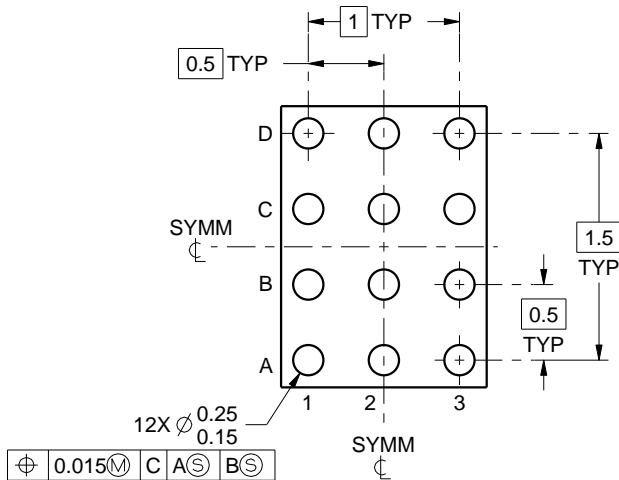
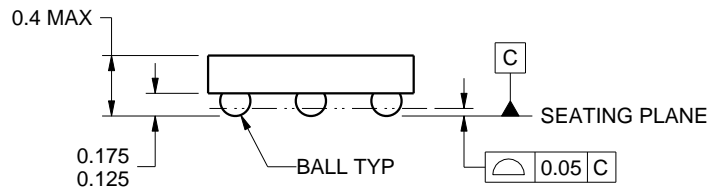
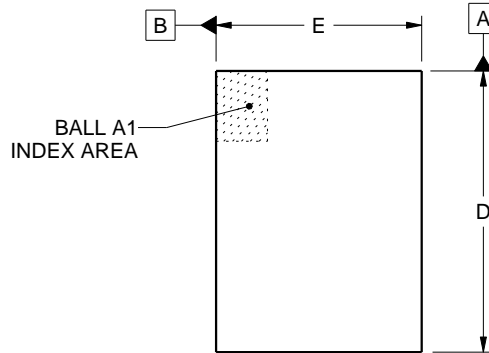
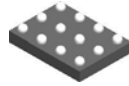
Device	Package Type	Package Drawing	Pins	SPQ	Length (mm)	Width (mm)	Height (mm)
BQ27Z561YPHR-R2	DSBGA	YPH	12	3000	182.0	182.0	20.0



D: Max = 2.08 mm, Min = 2.02 mm
 E: Max = 1.705 mm, Min = 1.644 mm

4222640/A 12/2015

NOTES:

NanoFree is a trademark of Texas Instruments.

1. All linear dimensions are in millimeters. Any dimensions in parenthesis are for reference only. Dimensioning and tolerancing per ASME Y14.5M.
2. This drawing is subject to change without notice.
3. NanoFree™ package configuration.

EXAMPLE BOARD LAYOUT

YPH0012

DSBGA - 0.4 mm max height

DIE SIZE BALL GRID ARRAY

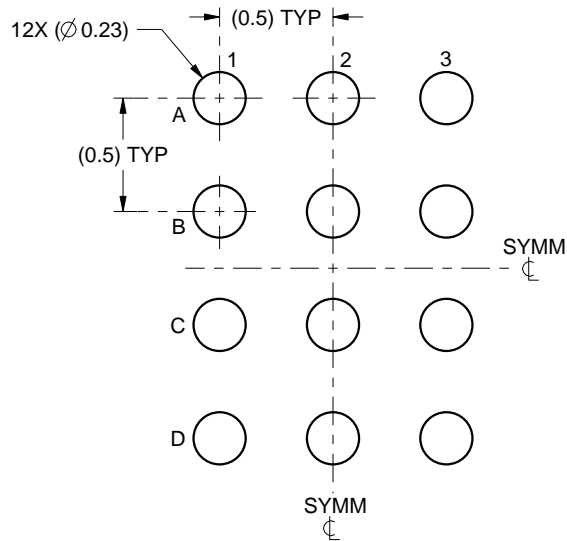

LAND PATTERN EXAMPLE
SCALE:30X

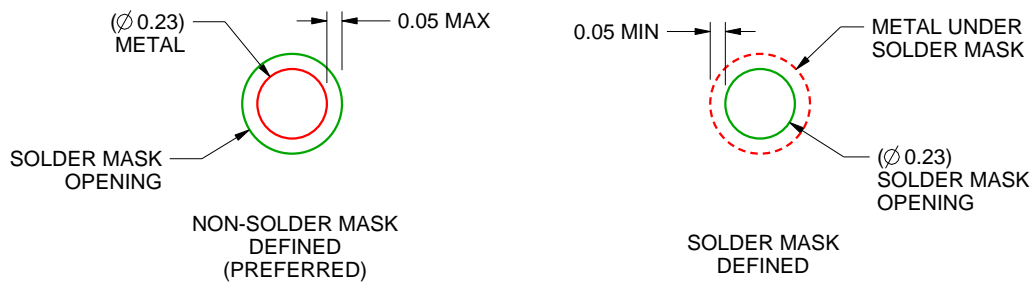

SOLDER MASK DETAILS
NOT TO SCALE

4222640/A 12/2015

NOTES: (continued)

- Final dimensions may vary due to manufacturing tolerance considerations and also routing constraints. For more information, see Texas Instruments literature number SNVA009 (www.ti.com/lit/snva009).

EXAMPLE STENCIL DESIGN

YPH0012

DSBGA - 0.4 mm max height

DIE SIZE BALL GRID ARRAY

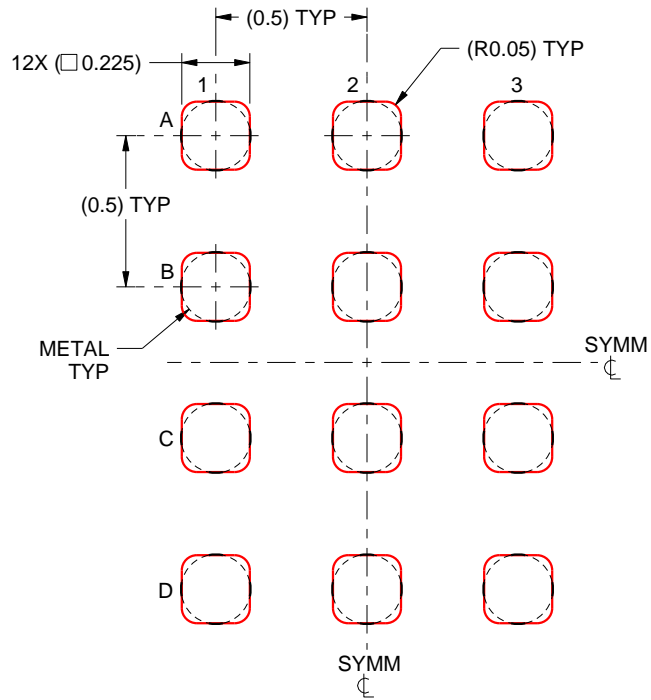

SOLDER PASTE EXAMPLE
BASED ON 0.1 mm THICK STENCIL
SCALE:40X

4222640/A 12/2015

NOTES: (continued)

5. Laser cutting apertures with trapezoidal walls and rounded corners may offer better paste release.

IMPORTANT NOTICE AND DISCLAIMER

TI PROVIDES TECHNICAL AND RELIABILITY DATA (INCLUDING DATASHEETS), DESIGN RESOURCES (INCLUDING REFERENCE DESIGNS), APPLICATION OR OTHER DESIGN ADVICE, WEB TOOLS, SAFETY INFORMATION, AND OTHER RESOURCES "AS IS" AND WITH ALL FAULTS, AND DISCLAIMS ALL WARRANTIES, EXPRESS AND IMPLIED, INCLUDING WITHOUT LIMITATION ANY IMPLIED WARRANTIES OF MERCHANTABILITY, FITNESS FOR A PARTICULAR PURPOSE OR NON-INFRINGEMENT OF THIRD PARTY INTELLECTUAL PROPERTY RIGHTS.

These resources are intended for skilled developers designing with TI products. You are solely responsible for (1) selecting the appropriate TI products for your application, (2) designing, validating and testing your application, and (3) ensuring your application meets applicable standards, and any other safety, security, regulatory or other requirements.

These resources are subject to change without notice. TI grants you permission to use these resources only for development of an application that uses the TI products described in the resource. Other reproduction and display of these resources is prohibited. No license is granted to any other TI intellectual property right or to any third party intellectual property right. TI disclaims responsibility for, and you fully indemnify TI and its representatives against any claims, damages, costs, losses, and liabilities arising out of your use of these resources.

TI's products are provided subject to [TI's Terms of Sale](#), [TI's General Quality Guidelines](#), or other applicable terms available either on ti.com or provided in conjunction with such TI products. TI's provision of these resources does not expand or otherwise alter TI's applicable warranties or warranty disclaimers for TI products. Unless TI explicitly designates a product as custom or customer-specified, TI products are standard, catalog, general purpose devices.

TI objects to and rejects any additional or different terms you may propose.

Copyright © 2025, Texas Instruments Incorporated

Last updated 10/2025