

54ACT16823, 74ACT16823 18-BIT BUS-INTERFACE FLIP-FLOPS WITH 3-STATE OUTPUTS

SCAS160B – APRIL 1991 – REVISED NOVEMBER 1999

- **EPIC™ (Enhanced-Performance Implanted CMOS) 1-μm Process**
- **Members of the Texas Instruments Widebus™ Family**
- **Inputs Are TTL-Voltage Compatible**
- **Provide Extra Data Width Necessary for Wider Address/Data Paths or Buses With Parity**
- **Flow-Through Architecture Optimizes PCB Layout**
- **Distributed V_{CC} and GND-Pin Configuration Minimizes High-Speed Switching Noise**
- **Package Options Include Plastic Shrink Small-Outline (DL) Packages Using 25-mil Center-to-Center Pin Spacings and 380-mil Fine-Pitch Ceramic Flat (WD) Packages Using 25-mil Center-to-Center Pin Spacings**

54ACT16823 . . . WD PACKAGE
74ACT16823 . . . DL PACKAGE
(TOP VIEW)

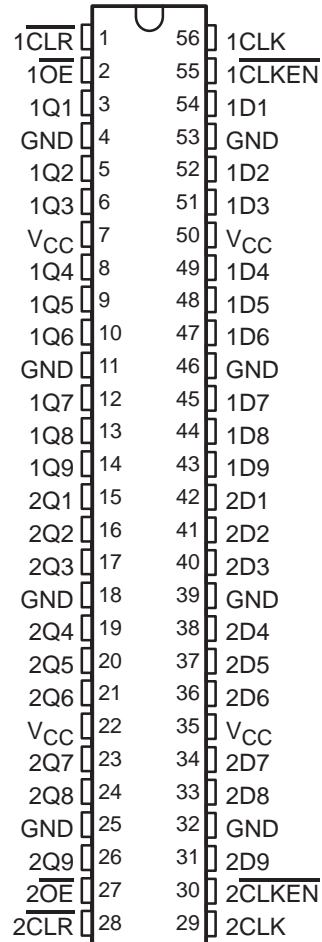

description

These 18-bit flip-flops feature 3-state outputs designed specifically for driving highly-capacitive or relatively low-impedance loads. They are particularly suitable for implementing wider buffer registers, I/O ports, parity bus interfacing, and working registers.

The 'ACT16823 devices can be used as two 9-bit flip-flops or one 18-bit flip-flop. With the clock-enable (CLKEN) input low, the D-type flip-flops enter data on the low-to-high transitions of the clock. Taking CLKEN high disables the clock buffer, thus latching the outputs. Taking the clear (CLR) input low causes the Q outputs to go low independently of the clock.

A buffered output-enable (\overline{OE}) input can be used to place the outputs in either a normal logic state (high or low logic levels) or the high-impedance state. In the high-impedance state, the outputs neither load nor drive the bus lines significantly.

\overline{OE} does not affect the internal operation of the flip-flops. Old data can be retained or new data can be entered while the outputs are in the high-impedance state.

The 54ACT16823 is characterized for operation over the full military temperature range of -55°C to 125°C . The 74ACT16823 is characterized for operation from -40°C to 85°C .



Please be aware that an important notice concerning availability, standard warranty, and use in critical applications of Texas Instruments semiconductor products and disclaimers thereto appears at the end of this data sheet.

EPIC and Widebus are trademarks of Texas Instruments Incorporated.

UNLESS OTHERWISE NOTED this document contains PRODUCTION DATA information current as of publication date. Products conform to specifications per the terms of Texas Instruments standard warranty. Production processing does not necessarily include testing of all parameters.

 **TEXAS
INSTRUMENTS**

POST OFFICE BOX 655303 • DALLAS, TEXAS 75265

Copyright © 1999, Texas Instruments Incorporated

54ACT16823, 74ACT16823
18-BIT BUS-INTERFACE FLIP-FLOPS
WITH 3-STATE OUTPUTS

SCAS160B – APRIL 1991 – REVISED NOVEMBER 1999

FUNCTION TABLE
 (each 9-bit stage)

INPUTS					OUTPUT
\overline{OE}	\overline{CLR}	\overline{CLKEN}	CLK	D	Q
L	L	X	X	X	L
L	H	L	↑	H	H
L	H	L	↑	L	L
L	H	L	L	X	Q ₀
L	H	H	X	X	Q ₀
H	X	X	X	X	Z

logic symbol†

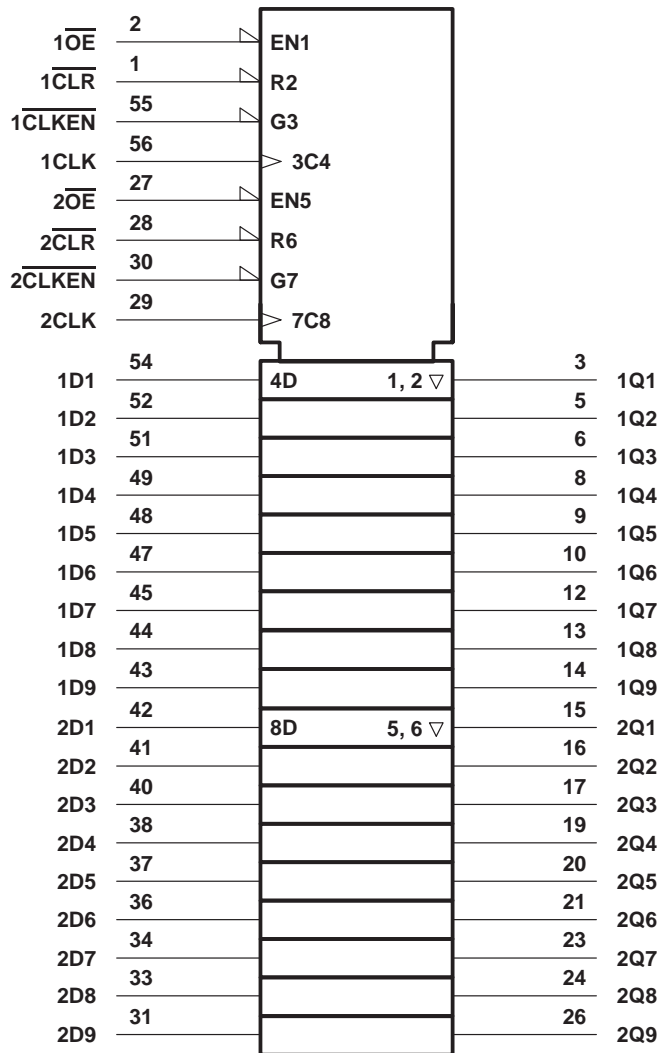

† This symbol is in accordance with ANSI/IEEE Std 91-1984 and IEC Publication 617-12.

logic diagram (positive logic)

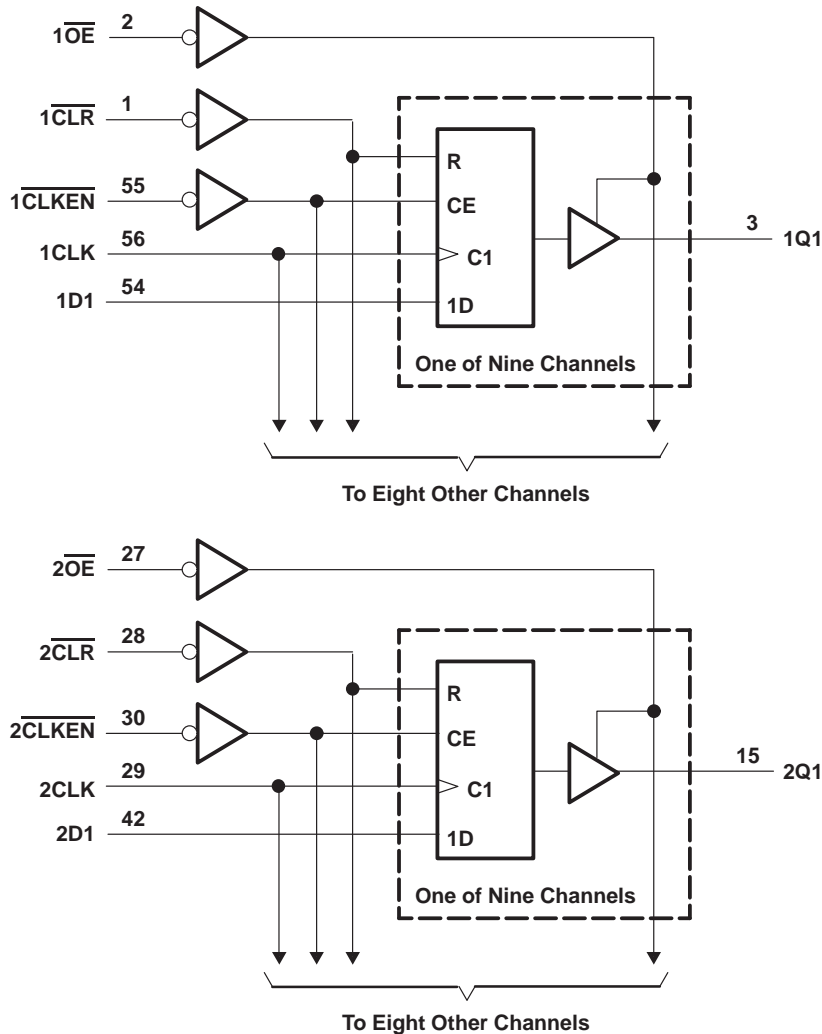

absolute maximum ratings over operating free-air temperature range (unless otherwise noted)†

Supply voltage range, V_{CC}	-0.5 V to 7 V
Input voltage range, V_I (see Note 1)	-0.5 V to $V_{CC} + 0.5$ V
Output voltage range, V_O (see Note 1)	-0.5 V to $V_{CC} + 0.5$ V
Input clamp current, I_{IK} ($V_I < 0$ or $V_I > V_{CC}$)	± 20 mA
Output clamp current, I_{OK} ($V_O < 0$ or $V_O > V_{CC}$)	± 50 mA
Continuous output current, I_O ($V_O = 0$ to V_{CC})	± 50 mA
Continuous current through V_{CC} or GND	± 450 mA
Package thermal impedance, θ_{JA} (see Note 2)	56°C/W
Storage temperature range, T_{stg}	-65°C to 150°C

† Stresses beyond those listed under "absolute maximum ratings" may cause permanent damage to the device. These are stress ratings only, and functional operation of the device at these or any other conditions beyond those indicated under "recommended operating conditions" is not implied. Exposure to absolute-maximum-rated conditions for extended periods may affect device reliability.

- NOTES: 1. The input and output voltage ratings may be exceeded if the input and output current ratings are observed.
 2. The package thermal impedance is calculated in accordance with JESD 51.

54ACT16823, 74ACT16823 18-BIT BUS-INTERFACE FLIP-FLOPS WITH 3-STATE OUTPUTS

SCAS160B – APRIL 1991 – REVISED NOVEMBER 1999

recommended operating conditions (see Note 3)

		54ACT16823			74ACT16823			UNIT
		MIN	NOM	MAX	MIN	NOM	MAX	
V_{CC}	Supply voltage	4.5	5	5.5	4.5	5	5.5	V
V_{IH}	High-level input voltage	2			2			V
V_{IL}	Low-level input voltage			0.8			0.8	V
V_I	Input voltage	0		V_{CC}	0		V_{CC}	V
V_O	Output voltage	0		V_{CC}	0		V_{CC}	V
I_{OH}	High-level output current			-24			-24	mA
I_{OL}	Low-level output current			24			24	mA
$\Delta t/\Delta v$	Input transition rise or fall rate	0		10	0		10	ns/V
T_A	Operating free-air temperature	-55		125	-40		85	°C

NOTE 3: All unused inputs of the device must be held at V_{CC} or GND to ensure proper device operation. Refer to the TI application report, *Implications of Slow or Floating CMOS Inputs*, literature number SCBA004.

electrical characteristics over recommended operating free-air temperature range (unless otherwise noted)

PARAMETER	TEST CONDITIONS	V_{CC}	$T_A = 25^\circ\text{C}$			54ACT16823		74ACT16823		UNIT
			MIN	TYP	MAX	MIN	MAX	MIN	MAX	
V_{OH}	$I_{OH} = -50 \mu\text{A}$	4.5 V	4.4			4.4		4.4	V	
		5.5 V	5.4			5.4		5.4		
	$I_{OH} = -24 \text{ mA}$	4.5 V	3.94			3.8		3.8		
		5.5 V	4.94			4.8		4.8		
	$I_{OH} = -75 \text{ mA}^\dagger$	5.5 V				3.85		3.85		
V_{OL}	$I_{OL} = 50 \mu\text{A}$	4.5 V			0.1		0.1		V	
		5.5 V			0.1		0.1			
	$I_{OL} = 24 \text{ mA}$	4.5 V			0.36		0.44			0.44
		5.5 V			0.36		0.44			0.44
	$I_{OL} = 75 \text{ mA}^\dagger$	5.5 V				1.65		1.65		
I_I	$V_I = V_{CC}$ or GND	5.5 V			± 0.1		± 1		μA	
I_{OZ}	$V_O = V_{CC}$ or GND	5.5 V			± 0.5		± 5		μA	
I_{CC}	$V_I = V_{CC}$ or GND, $I_O = 0$	5.5 V			8		80		μA	
ΔI_{CC}^\ddagger	One input at 3.4 V, Other inputs at V_{CC} or GND	5.5 V			0.9		1		mA	
C_i	$V_I = V_{CC}$ or GND	5 V			3				pF	
C_o	$V_O = V_{CC}$ or GND	5 V			12				pF	

† Not more than one output should be tested at a time, and the duration of the test should not exceed 10 ms.

‡ This is the increase in supply current for each input that is at one of the specified TTL voltage levels rather than 0 V or V_{CC} .

PRODUCT PREVIEW information concerns products in the formative or design phase of development. Characteristic data and other specifications are design goals. Texas Instruments reserves the right to change or discontinue these products without notice.



54ACT16823, 74ACT16823
18-BIT BUS-INTERFACE FLIP-FLOPS
WITH 3-STATE OUTPUTS

SCAS160B – APRIL 1991 – REVISED NOVEMBER 1999

timing requirements over recommended operating free-air temperature range, $V_{CC} = 5\text{ V} \pm 0.5\text{ V}$ (unless otherwise noted) (see Figure 1)

		$T_A = 25^\circ\text{C}$		54ACT16823		74ACT16823		UNIT
		MIN	MAX	MIN	MAX	MIN	MAX	
f_{clock}	Clock frequency	90		90		90		MHz
t_w	Pulse duration	$\overline{\text{CLR}}$ low		3.3		3.3		ns
		CLK high or low		5.5		5.5		
t_{su}	Setup time before $\text{CLK}\uparrow$	$\overline{\text{CLR}}$ inactive		0.5		0.5		ns
		Data		7		7		
		CLKEN low		3.5		3.5		
t_h	Hold time after $\text{CLK}\uparrow$	Data		0.5		0.5		ns
		CLKEN high or low		2.5		2.5		

switching characteristics over recommended operating free-air temperature range, $V_{CC} = 5\text{ V} \pm 0.5\text{ V}$ (unless otherwise noted) (see Figure 1)

PARAMETER	FROM (INPUT)	TO (OUTPUT)	$T_A = 25^\circ\text{C}$			54ACT16823		74ACT16823		UNIT
			MIN	TYP	MAX	MIN	MAX	MIN	MAX	
f_{max}			90			90		90	MHz	
t_{PLH}	CLK	Q	4.2	7.5	10.6	4.2	12.1	4.2	12.1	ns
t_{PHL}			4.8	8.3	11.5	4.8	12.9	4.8	12.9	
t_{PHL}	$\overline{\text{CLR}}$	Q	3.4	7.3	11.2	3.4	12.5	3.4	12.5	ns
t_{PZH}	$\overline{\text{OE}}$	Q	2.4	5.9	9.5	2.4	10.7	2.4	10.7	ns
t_{PZL}			3.3	7.1	11.3	3.3	12.8	3.3	12.8	
t_{PHZ}	$\overline{\text{OE}}$	Q	5.5	7.6	9.7	5.5	10.3	5.5	10.3	ns
t_{PLZ}			4.6	6.7	8.8	4.6	9.4	4.6	9.4	

operating characteristics, $V_{CC} = 5\text{ V}$, $T_A = 25^\circ\text{C}$

PARAMETER		TEST CONDITIONS	TYP	UNIT
C_{pd}	Power dissipation capacitance	Outputs enabled	42	pF
		Outputs disabled	24	

PRODUCT PREVIEW information concerns products in the formative or design phase of development. Characteristic data and other specifications are design goals. Texas Instruments reserves the right to change or discontinue these products without notice.



54ACT16823, 74ACT16823
 18-BIT BUS-INTERFACE FLIP-FLOPS
 WITH 3-STATE OUTPUTS

SCAS160B – APRIL 1991 – REVISED NOVEMBER 1999

PARAMETER MEASUREMENT INFORMATION

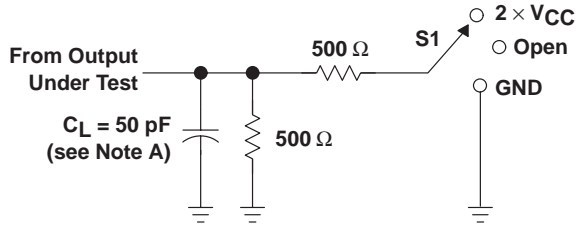

LOAD CIRCUIT

TEST	S1
t_{PLH}/t_{PHL}	Open
t_{PLZ}/t_{PZL}	$2 \times V_{CC}$
t_{PHZ}/t_{PZH}	GND

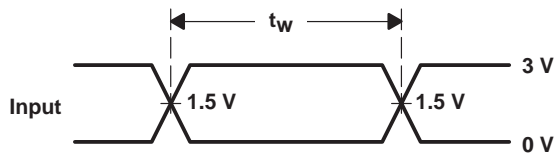

VOLTAGE WAVEFORMS

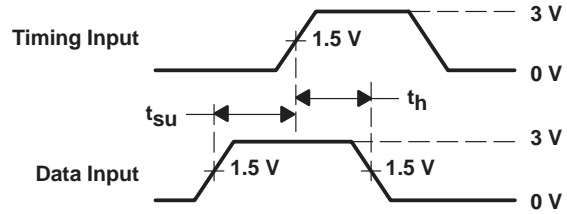

VOLTAGE WAVEFORMS

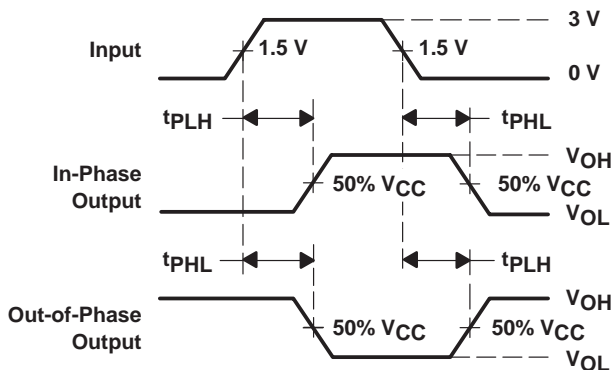

VOLTAGE WAVEFORMS

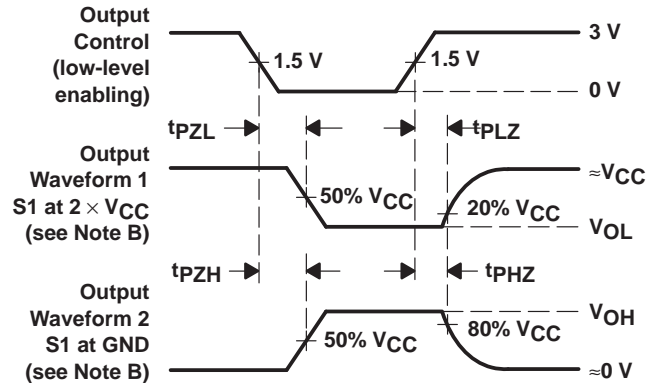

VOLTAGE WAVEFORMS

- NOTES: A. C_L includes probe and jig capacitance.
 B. Waveform 1 is for an output with internal conditions such that the output is low except when disabled by the output control. Waveform 2 is for an output with internal conditions such that the output is high except when disabled by the output control.
 C. All input pulses are supplied by generators having the following characteristics: $PRR \leq 1$ MHz, $Z_O = 50 \Omega$, $t_r = 3$ ns, $t_f = 3$ ns.
 D. The outputs are measured one at a time with one input transition per measurement.

Figure 1. Load Circuit and Voltage Waveforms

PACKAGING INFORMATION

Orderable part number	Status (1)	Material type (2)	Package Pins	Package qty Carrier	RoHS (3)	Lead finish/ Ball material (4)	MSL rating/ Peak reflow (5)	Op temp (°C)	Part marking (6)
74ACT16823DLR	Active	Production	SSOP (DL) 56	1000 LARGE T&R	Yes	NIPDAU	Level-1-260C-UNLIM	-40 to 85	ACT16823
74ACT16823DLR.A	Active	Production	SSOP (DL) 56	1000 LARGE T&R	Yes	NIPDAU	Level-1-260C-UNLIM	-40 to 85	ACT16823

(1) **Status:** For more details on status, see our [product life cycle](#).

(2) **Material type:** When designated, preproduction parts are prototypes/experimental devices, and are not yet approved or released for full production. Testing and final process, including without limitation quality assurance, reliability performance testing, and/or process qualification, may not yet be complete, and this item is subject to further changes or possible discontinuation. If available for ordering, purchases will be subject to an additional waiver at checkout, and are intended for early internal evaluation purposes only. These items are sold without warranties of any kind.

(3) **RoHS values:** Yes, No, RoHS Exempt. See the [TI RoHS Statement](#) for additional information and value definition.

(4) **Lead finish/Ball material:** Parts may have multiple material finish options. Finish options are separated by a vertical ruled line. Lead finish/Ball material values may wrap to two lines if the finish value exceeds the maximum column width.

(5) **MSL rating/Peak reflow:** The moisture sensitivity level ratings and peak solder (reflow) temperatures. In the event that a part has multiple moisture sensitivity ratings, only the lowest level per JEDEC standards is shown. Refer to the shipping label for the actual reflow temperature that will be used to mount the part to the printed circuit board.

(6) **Part marking:** There may be an additional marking, which relates to the logo, the lot trace code information, or the environmental category of the part.

Multiple part markings will be inside parentheses. Only one part marking contained in parentheses and separated by a "~" will appear on a part. If a line is indented then it is a continuation of the previous line and the two combined represent the entire part marking for that device.

Important Information and Disclaimer:The information provided on this page represents TI's knowledge and belief as of the date that it is provided. TI bases its knowledge and belief on information provided by third parties, and makes no representation or warranty as to the accuracy of such information. Efforts are underway to better integrate information from third parties. TI has taken and continues to take reasonable steps to provide representative and accurate information but may not have conducted destructive testing or chemical analysis on incoming materials and chemicals. TI and TI suppliers consider certain information to be proprietary, and thus CAS numbers and other limited information may not be available for release.

In no event shall TI's liability arising out of such information exceed the total purchase price of the TI part(s) at issue in this document sold by TI to Customer on an annual basis.

TAPE AND REEL INFORMATION

QUADRANT ASSIGNMENTS FOR PIN 1 ORIENTATION IN TAPE

*All dimensions are nominal

Device	Package Type	Package Drawing	Pins	SPQ	Reel Diameter (mm)	Reel Width W1 (mm)	A0 (mm)	B0 (mm)	K0 (mm)	P1 (mm)	W (mm)	Pin1 Quadrant
74ACT16823DLR	SSOP	DL	56	1000	330.0	32.4	11.35	18.67	3.1	16.0	32.0	Q1

TAPE AND REEL BOX DIMENSIONS



*All dimensions are nominal

Device	Package Type	Package Drawing	Pins	SPQ	Length (mm)	Width (mm)	Height (mm)
74ACT16823DLR	SSOP	DL	56	1000	356.0	356.0	53.0

MECHANICAL DATA

DL (R-PDSO-G56)

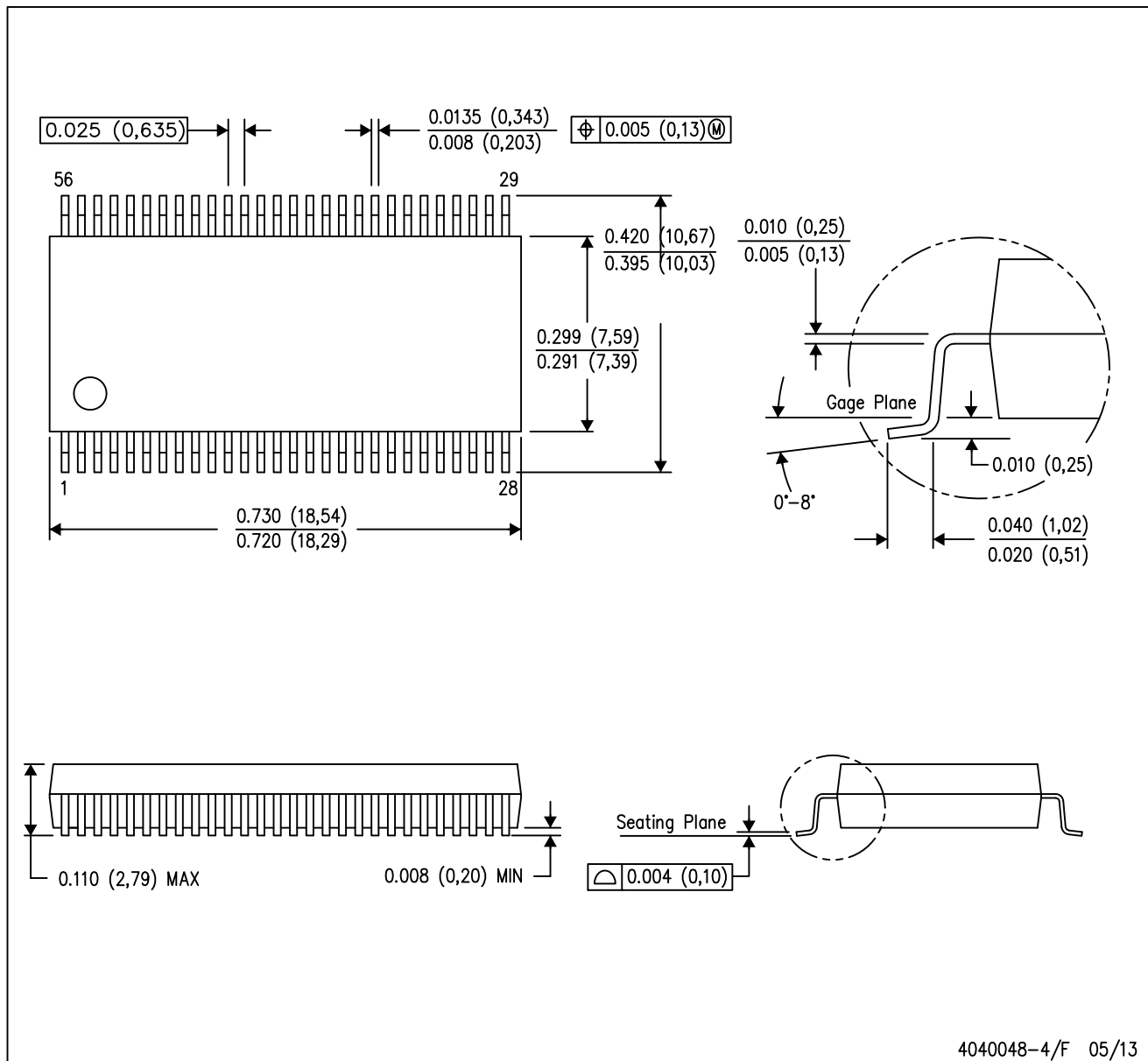
PLASTIC SMALL-OUTLINE PACKAGE



- NOTES:
- A. All linear dimensions are in inches (millimeters).
 - B. This drawing is subject to change without notice.
 - C. Body dimensions do not include mold flash or protrusion not to exceed 0.006 (0,15).
 - D. Falls within JEDEC MO-118

PowerPAD is a trademark of Texas Instruments.

IMPORTANT NOTICE AND DISCLAIMER

TI PROVIDES TECHNICAL AND RELIABILITY DATA (INCLUDING DATASHEETS), DESIGN RESOURCES (INCLUDING REFERENCE DESIGNS), APPLICATION OR OTHER DESIGN ADVICE, WEB TOOLS, SAFETY INFORMATION, AND OTHER RESOURCES "AS IS" AND WITH ALL FAULTS, AND DISCLAIMS ALL WARRANTIES, EXPRESS AND IMPLIED, INCLUDING WITHOUT LIMITATION ANY IMPLIED WARRANTIES OF MERCHANTABILITY, FITNESS FOR A PARTICULAR PURPOSE OR NON-INFRINGEMENT OF THIRD PARTY INTELLECTUAL PROPERTY RIGHTS.

These resources are intended for skilled developers designing with TI products. You are solely responsible for (1) selecting the appropriate TI products for your application, (2) designing, validating and testing your application, and (3) ensuring your application meets applicable standards, and any other safety, security, regulatory or other requirements.

These resources are subject to change without notice. TI grants you permission to use these resources only for development of an application that uses the TI products described in the resource. Other reproduction and display of these resources is prohibited. No license is granted to any other TI intellectual property right or to any third party intellectual property right. TI disclaims responsibility for, and you fully indemnify TI and its representatives against any claims, damages, costs, losses, and liabilities arising out of your use of these resources.

TI's products are provided subject to [TI's Terms of Sale](#), [TI's General Quality Guidelines](#), or other applicable terms available either on [ti.com](#) or provided in conjunction with such TI products. TI's provision of these resources does not expand or otherwise alter TI's applicable warranties or warranty disclaimers for TI products. Unless TI explicitly designates a product as custom or customer-specified, TI products are standard, catalog, general purpose devices.

TI objects to and rejects any additional or different terms you may propose.

Copyright © 2026, Texas Instruments Incorporated

Last updated 10/2025