

SNx4ACT00 四路双输入正与非门

1 特性

- 4.5V 至 5.5V V_{CC} 运行
- 输入电压高达 5.5V
- 5V 时, t_{pd} 最大值为 8ns
- 输入兼容 TTL 电压

2 说明

‘ACT00 器件包含四个独立双输入与非门。每个逻辑门以正逻辑执行布尔函数 $Y = A \cdot B$ 或 $Y = \overline{A+B}$ 。

器件信息

器件型号	封装 ⁽¹⁾	封装尺寸 ⁽²⁾	本体尺寸 ⁽³⁾
SNx4ACT00	D (SOIC , 14)	8.65mm × 6mm	8.65mm × 3.9mm
	DB (SSOP , 14)	6.20mm × 7.8mm	6.20mm × 5.30mm
	N (PDIP , 14)	19.30mm × 9.4mm	19.30mm × 6.35mm
	NS (SOP , 14)	10.2mm × 7.8mm	10.30mm × 5.30mm
	PW (TSSOP , 14)	5mm × 6.4mm	5mm × 4.4mm
	BQA (WQFN , 14)	3mm × 2.5mm	3mm × 2.5mm

- (1) 有关更多信息, 请参阅节 10。
- (2) 封装尺寸 (长 × 宽) 为标称值, 并包括引脚 (如适用)。
- (3) 本体尺寸 (长 × 宽) 为标称值, 不包括引脚。



逻辑图, 每个逻辑门 (正逻辑)



内容

1 特性	1	6.2 器件功能模式.....	7
2 说明	1	7 应用和实施	8
3 引脚配置和功能	3	7.1 电源相关建议.....	8
4 规格	5	7.2 布局.....	8
4.1 绝对最大额定值.....	5	8 器件和文档支持	9
4.2 建议运行条件.....	5	8.1 文档支持 (模拟)	9
4.3 热性能信息.....	5	8.2 接收文档更新通知.....	9
4.4 电气特性.....	6	8.3 支持资源.....	9
4.5 开关特性.....	6	8.4 商标.....	9
4.6 工作特性.....	6	8.5 静电放电警告.....	9
5 参数测量信息	7	8.6 术语表.....	9
6 详细说明	7	9 修订历史记录	9
6.1 功能方框图.....	7	10 机械、封装和可订购信息	10

3 引脚配置和功能



图 3-1. SN54ACT00 J 或 W 封装；SN74ACT00 D、DB、N、NS 或 PW 封装 (顶视图)



图 3-2. SN74ACT00 BQA 封装 (透明顶视图)

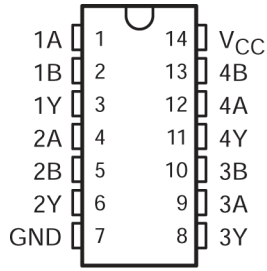

NC - No internal connection

图 3-3. SN54ACT00 FK 封装 (顶视图)

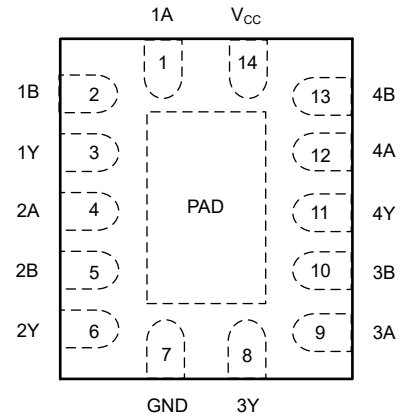
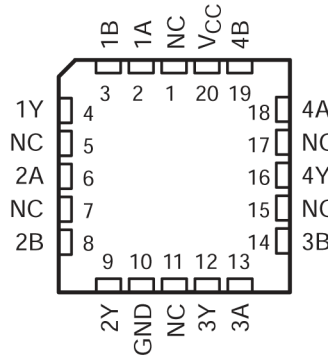
表 3-1. 引脚功能

引脚			类型 ⁽¹⁾	说明
名称	BQA、D、DB、J、N、NS、PW 或 W 编号	FK 编号		
1A	1	2	I	通道 1, 输入 A
1B	2	3	I	通道 1, 输入 B
1Y	3	4	O	通道 1, 输出 Y
2A	4	6	I	通道 2, 输入 A
2B	5	8	I	通道 2, 输入 B
2Y	6	9	O	通道 2, 输出 Y
3A	9	13	O	通道 3, 输出 Y
3B	10	14	I	通道 3, 输入 A
3Y	8	12	I	通道 3, 输入 B
4A	12	18	O	通道 4, 输出 Y
4B	13	19	I	通道 4, 输入 A
4Y	11	16	I	通道 4, 输入 B
GND	7	10	G	接地
V _{CC}	14	20	P	正电源

表 3-1. 引脚功能 (续)

引脚			类型 ⁽¹⁾	说明
名称	BQA、D、DB、J、N、NS、PW 或 W 编号	FK 编号		
NC	-	1、5、7、11、15、17	-	无内部连接
散热焊盘 ⁽²⁾			-	散热焊盘可连接到 GND 或悬空。请勿连接到任何其他信号或电源

(1) 信号类型：I = 输入，O = 输出，I/O = 输入或输出，P = 电源，G = 接地。

(2) 仅限 BQA 封装。

4 规格

4.1 绝对最大额定值

在自然通风条件下的工作温度范围内测得 (除非另有说明) ⁽¹⁾

		最小值	最大值	单位
V _{CC}	电源电压范围	-0.5	7	V
V _I ⁽²⁾	输入电压范围	-0.5	V _{CC} + 0.5	V
V _O ⁽²⁾	输出电压范围	-0.5	V _{CC} + 0.5	V
I _{IK}	输入钳位电流	(V _I < 0 或 V _I > V _{CC})		±20 mA
I _{OK}	输出钳位电流	(V _O < 0 或 V _O > V _{CC})		±20 mA
I _O	持续输出电流	(V _O = 0 至 V _{CC})		±50 mA
通过 V _{CC} 或 GND 的持续电流				±200 mA
T _{stg}	贮存温度范围	-65	150	°C

- (1) 应力超出“绝对最大额定值”下列出的值可能会对器件造成永久损坏。这些列出的值仅仅是应力额定值，这并不表示器件在这些条件下以及在“建议运行条件”以外的任何其他条件下能够正常运行。长时间处于绝对最大额定条件下可能会影响器件的可靠性。
- (2) 如果遵守输入和输出电流额定值，输入和输出电压可超过额定值。

4.2 建议运行条件

在自然通风条件下的工作温度范围内测得 (除非另有说明) ⁽¹⁾

		SN54ACT00		SN74ACT00		单位
		最小值	最大值	最小值	最大值	
V _{CC}	电源电压	4.5	5.5	4.5	5.5	V
V _{IH}	高电平输入电压	2		2		V
V _{IL}	低电平输入电压		0.8		0.8	V
V _I	输入电压	0	V _{CC}	0	V _{CC}	V
V _O	输出电压	0	V _{CC}	0	V _{CC}	V
I _{OH}	高电平输出电流		-24		-24	mA
I _{OL}	低电平输出电流		24		24	mA
Δt/Δv	输入转换上升或下降速率		8		8	ns/V
T _A	自然通风条件下的工作温度范围	-55	125	-40	85	°C

- (1) 器件的所有未使用输入必须保持在 V_{CC} 或 GND 以确保器件正常运行。请参阅 TI 应用报告 *CMOS 输入缓慢变化或悬空的影响*，文献编号 SCBA004。

4.3 热性能信息

热指标 ⁽¹⁾		SNx4ACT00						单位
		D (SOIC)	DB (SSOP)	N (PDIP)	NS (SOP)	PW (TSSOP)	BQA (WQFN)	
		14 引脚	14 引脚	14 引脚	14 引脚	14 引脚	14 引脚	
R _{θJA}	结至环境热阻	119.9	96	80	76	145.7	91.3	°C/W
R _{θJC(top)}	结至外壳 (顶部) 热阻	—	—	—	—	—	99.4	°C/W
R _{θJB}	结至电路板热阻	—	—	—	—	—	61.0	°C/W
Ψ _{JT}	结至顶部特征参数	—	—	—	—	—	14.5	°C/W
Ψ _{JB}	结至电路板特征参数	—	—	—	—	—	60.8	°C/W
R _{θJC(bot)}	结至外壳 (底部) 热阻	—	—	—	—	—	37.0	°C/W

- (1) 有关新旧热指标的更多信息，请参阅 *半导体和 IC 封装热指标* 应用手册。

4.4 电气特性

在自然通风条件下的建议运行温度范围内测得（除非另有说明）

参数	测试条件	V _{CC}	T _A = 25°C			SN54ACT00		SN74ACT00		单位
			最小值	典型值	最大值	最小值	最大值	最小值	最大值	
V _{OH}	I _{OH} = -50μA	4.5V	4.4	4.49		4.4		4.4	V	
		5.5V	5.4	5.49		5.4		5.4		
	I _{OH} = -24mA	4.5V	3.86			3.7	3.76			
		5.5V	4.86			4.7	4.76			
	I _{OH} = -50mA ⁽¹⁾	5.5V				3.85				
I _{OH} = -75mA ⁽¹⁾	5.5V					3.85				
V _{OL}	I _{OL} = 50μA	4.5V	0.001		0.1	0.1		0.1	V	
		5.5V	0.001		0.1	0.1		0.1		
	I _{OH} = 24mA	4.5V				0.36	0.5			0.44
		5.5V				0.36	0.5			0.44
	I _{OH} = 50mA ⁽¹⁾	5.5V				1.65				
I _{OH} = 75mA ⁽¹⁾	5.5V						1.65			
I _I	V _I = V _{CC} 或 GND	5.5V				±0.1	±1		μA	
I _{CC}	V _I = V _{CC} 或 GND I _O = 0	5.5V				2	40		20	μA
ΔI _{CC} ⁽²⁾	一个输入电压为 3.4V，其他输入电压为 GND 或 V _{CC}	5.5V				0.6	1.6		1.5	mA
C _i	V _I = V _{CC} 或 GND	5V				2.6				pF

(1) 一次不应测试超过一个输出，且测试持续时间不应超过 2ms。

(2) 这是每个输入在指定 TTL 电压电平之一而不是 0V 或 V_{CC} 时电源电流的增加情况。

4.5 开关特性

在自然通风条件下的建议工作温度范围内测得，V_{CC} = 5V ± 0.5V（除非另有说明）（参阅[负载电路与电压波形](#)）

参数	从 (输入)	至 (输出)	T _A = 25°C			SNx4ACT00		SNx4ACT00		单位
			最小值	典型值	最大值	最小值	最大值	最小值	最大值	
t _{PLH}	A 或 B	Y	1.5	5.5	9	1	9.5	1	9.5	ns
t _{PHL}			1.5	4	7	1	7	1	8	

4.6 工作特性

V_{CC} = 5V, T_A = 25°C

参数		测试条件		典型值	单位
C _{pd}	功率耗散电容	C _L = 50pF	f = 1MHz	40	pF

5 参数测量信息

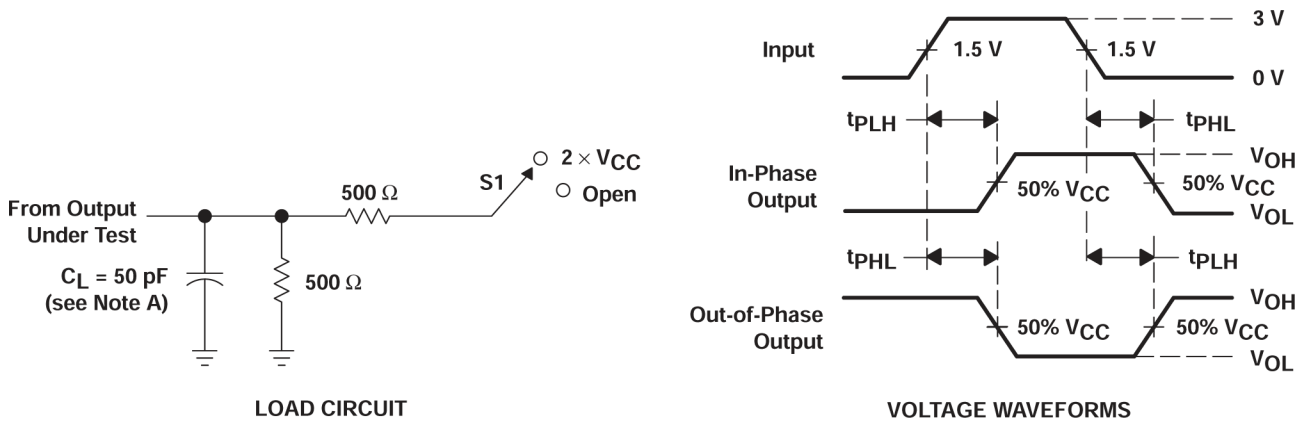

- A. C_L 包括探头和夹具电容。
 B. 所有输入脉冲均由具有以下特性的发生器提供： $PRR \leq 1\text{MHz}$ ， $Z_O = 50\ \Omega$ ， $t_r \leq 2.5\text{ns}$ ， $t_f \leq 2.5\text{ns}$ 。
 C. 一次测量一个输出，每次测量一个输入转换。

图 5-1. 负载电路和电压波形

测试	S1
t_{PLH}/t_{PHL}	开路

6 详细说明

6.1 功能方框图



图 6-1. 逻辑图，每个逻辑门（正逻辑）

6.2 器件功能模式

表 6-1. 功能表（每个逻辑门）

输入		输出
A	B	Y
H	H	L
L	X	H
X	L	H

7 应用和实例

备注

以下应用部分中的信息不属于 TI 器件规格的范围，TI 不担保其准确性和完整性。TI 的客户应负责确定器件是否适用于其应用。客户应验证并测试其设计，以确保系统功能。

7.1 电源相关建议

电源可以是 *建议运行条件* 中最小和最大电源电压额定值之间的任何电压。每个 V_{CC} 端子均应具有一个良好的旁路电容器，以防止功率干扰。建议为该器件使用 $0.1\ \mu\text{F}$ 电容。可以并联多个旁路电容器以抑制不同的噪声频率。 $0.1\ \mu\text{F}$ 和 $1\ \mu\text{F}$ 电容器通常并联使用。旁路电容器应安装在尽可能靠近电源端子的位置，以获得更佳效果，如以下布局示例所示。

7.2 布局

7.2.1 布局指南

使用多输入和多通道逻辑器件时，输入不得悬空。在许多情况下，未使用数字逻辑器件的全部或部分功能；例如，仅使用三输入与门的两个输入或仅使用 4 个缓冲门中的 3 个。此类未使用的输入引脚不得悬空，因为外部连接处的未定义电压会导致未定义的操作状态。数字逻辑器件的所有未使用输入必须连接到由输入电压规范定义的逻辑高电平电压或逻辑低电平电压，以防止其悬空。必须应用于任何特定未使用输入的逻辑电平取决于器件的功能。通常，输入连接到 GND 或 V_{CC} ，以对逻辑功能更有意义或更方便者为准。

7.2.2 布局示例



图 7-1. SNx4ACT00 的示例布局

8 器件和文档支持

TI 提供广泛的开发工具。下面列出了用于评估器件性能、生成代码和开发解决方案的工具和软件。

8.1 文档支持 (模拟)

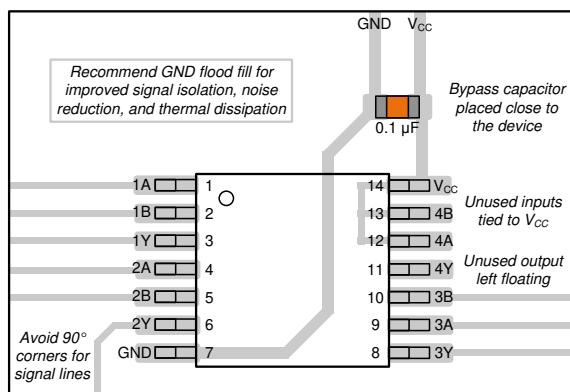
8.1.1 相关文档

下表列出了快速访问链接。类别包括技术文档、支持和社区资源、工具和软件，以及申请样片或购买产品的快速链接。

表 8-1. 相关链接

器件	产品文件夹	样片与购买	技术文档	工具和软件	支持和社区
SN54ACT00	点击此处	点击此处	点击此处	点击此处	点击此处
SN74ACT00	点击此处	点击此处	点击此处	点击此处	点击此处

8.2 接收文档更新通知

要接收文档更新通知，请导航至 ti.com 上的器件产品文件夹。点击 [通知](#) 进行注册，即可每周接收产品信息更改摘要。有关更改的详细信息，请查看任何已修订文档中包含的修订历史记录。

8.3 支持资源

[TI E2E™ 中文支持论坛](#) 是工程师的重要参考资料，可直接从专家处获得快速、经过验证的解答和设计帮助。搜索现有解答或提出自己的问题，获得所需的快速设计帮助。

链接的内容由各个贡献者“按原样”提供。这些内容并不构成 TI 技术规范，并且不一定反映 TI 的观点；请参阅 TI 的 [使用条款](#)。

8.4 商标

TI E2E™ is a trademark of Texas Instruments.

所有商标均为其各自所有者的财产。

8.5 静电放电警告



静电放电 (ESD) 会损坏这个集成电路。德州仪器 (TI) 建议通过适当的预防措施处理所有集成电路。如果不遵守正确的处理和安装程序，可能会损坏集成电路。

ESD 的损坏小至导致微小的性能降级，大至整个器件故障。精密的集成电路可能更容易受到损坏，这是因为非常细微的参数更改都可能会导致器件与其发布的规格不相符。

8.6 术语表

[TI 术语表](#) 本术语表列出并解释了术语、首字母缩略词和定义。

9 修订历史记录

注：以前版本的页码可能与当前版本的页码不同

Changes from Revision E (July 2024) to Revision F (April 2025)	Page
• 向数据表添加了 BQA 封装.....	1
• 添加了 BQA 引脚排列图像和表条目。.....	3

Changes from Revision D (October 2003) to Revision E (July 2024)	Page
• 添加了应用部分、器件信息表、引脚功能表、ESD 等级表、热性能信息表、器件功能模式、应用和实施部分、器件和文档支持部分以及机械、封装和可订购信息部分.....	1

-
- 更新了 $R_{\theta JA}$ 值：D = 86 至 119.9，PW = 113 至 145.7，所有值均以 $^{\circ}\text{C/W}$ 为单位..... 5
-

10 机械、封装和可订购信息

以下页面包含机械、封装和可订购信息。这些信息是指定器件可用的最新数据。数据如有变更，恕不另行通知，且不会对此文档进行修订。有关此数据表的浏览器版本，请查阅左侧的导航栏。

PACKAGING INFORMATION

Orderable part number	Status (1)	Material type (2)	Package Pins	Package qty Carrier	RoHS (3)	Lead finish/ Ball material (4)	MSL rating/ Peak reflow (5)	Op temp (°C)	Part marking (6)
5962-8769901M2A	Active	Production	LCCC (FK) 20	55 TUBE	No	SNPB	N/A for Pkg Type	-55 to 125	5962-8769901M2A SNJ54 ACT00FK
5962-8769901MCA	NRND	Production	CDIP (J) 14	25 TUBE	No	SNPB	N/A for Pkg Type	-55 to 125	5962-8769901MC A SNJ54ACT00J
5962-8769901MDA	Active	Production	CFP (W) 14	25 TUBE	No	SNPB	N/A for Pkg Type	-55 to 125	5962-8769901MD A SNJ54ACT00W
SN74ACT00BQAR	Active	Production	WQFN (BQA) 14	3000 LARGE T&R	Yes	NIPDAU	Level-1-260C-UNLIM	-40 to 85	AD00
SN74ACT00BQAR.A	Active	Production	WQFN (BQA) 14	3000 LARGE T&R	Yes	NIPDAU	Level-1-260C-UNLIM	-40 to 85	AD00
SN74ACT00D	Obsolete	Production	SOIC (D) 14	-	-	Call TI	Call TI	-40 to 85	ACT00
SN74ACT00DBR	Active	Production	SSOP (DB) 14	2000 LARGE T&R	Yes	NIPDAU	Level-1-260C-UNLIM	-40 to 85	AD00
SN74ACT00DBR.A	Active	Production	SSOP (DB) 14	2000 LARGE T&R	Yes	NIPDAU	Level-1-260C-UNLIM	-40 to 85	AD00
SN74ACT00DR	Active	Production	SOIC (D) 14	2500 LARGE T&R	Yes	NIPDAU	Level-1-260C-UNLIM	-40 to 85	ACT00
SN74ACT00DR.A	Active	Production	SOIC (D) 14	2500 LARGE T&R	Yes	NIPDAU	Level-1-260C-UNLIM	-40 to 85	ACT00
SN74ACT00DR1G4	Active	Production	SOIC (D) 14	2500 LARGE T&R	Yes	NIPDAU	Level-1-260C-UNLIM	-40 to 85	ACT00
SN74ACT00DR1G4.A	Active	Production	SOIC (D) 14	2500 LARGE T&R	Yes	NIPDAU	Level-1-260C-UNLIM	-40 to 85	ACT00
SN74ACT00N	Active	Production	PDIP (N) 14	25 TUBE	Yes	NIPDAU	N/A for Pkg Type	-40 to 85	SN74ACT00N
SN74ACT00N.A	Active	Production	PDIP (N) 14	25 TUBE	Yes	NIPDAU	N/A for Pkg Type	-40 to 85	SN74ACT00N
SN74ACT00NE4	Active	Production	PDIP (N) 14	25 TUBE	Yes	NIPDAU	N/A for Pkg Type	-40 to 85	SN74ACT00N
SN74ACT00NSR	Active	Production	SOP (NS) 14	2000 LARGE T&R	Yes	NIPDAU	Level-1-260C-UNLIM	-40 to 85	ACT00
SN74ACT00NSR.A	Active	Production	SOP (NS) 14	2000 LARGE T&R	Yes	NIPDAU	Level-1-260C-UNLIM	-40 to 85	ACT00
SN74ACT00PW	Obsolete	Production	TSSOP (PW) 14	-	-	Call TI	Call TI	-40 to 85	AD00
SN74ACT00PWR	Active	Production	TSSOP (PW) 14	2000 LARGE T&R	Yes	NIPDAU SN	Level-1-260C-UNLIM	-40 to 85	AD00
SN74ACT00PWR.A	Active	Production	TSSOP (PW) 14	2000 LARGE T&R	Yes	NIPDAU	Level-1-260C-UNLIM	-40 to 85	AD00
SN74ACT00PWRG4	Active	Production	TSSOP (PW) 14	2000 LARGE T&R	Yes	NIPDAU	Level-1-260C-UNLIM	-40 to 85	AD00
SN74ACT00PWRG4.A	Active	Production	TSSOP (PW) 14	2000 LARGE T&R	Yes	NIPDAU	Level-1-260C-UNLIM	-40 to 85	AD00

Orderable part number	Status (1)	Material type (2)	Package Pins	Package qty Carrier	RoHS (3)	Lead finish/ Ball material (4)	MSL rating/ Peak reflow (5)	Op temp (°C)	Part marking (6)
SNJ54ACT00FK	Active	Production	LCCC (FK) 20	55 TUBE	No	SNPB	N/A for Pkg Type	-55 to 125	5962-8769901M2A SNJ54 ACT00FK
SNJ54ACT00FK.A	Active	Production	LCCC (FK) 20	55 TUBE	No	SNPB	N/A for Pkg Type	-55 to 125	5962-8769901M2A SNJ54 ACT00FK
SNJ54ACT00J	NRND	Production	CDIP (J) 14	25 TUBE	No	SNPB	N/A for Pkg Type	-55 to 125	5962-8769901MC A SNJ54ACT00J
SNJ54ACT00J.A	NRND	Production	CDIP (J) 14	25 TUBE	No	SNPB	N/A for Pkg Type	-55 to 125	5962-8769901MC A SNJ54ACT00J
SNJ54ACT00W	Active	Production	CFP (W) 14	25 TUBE	No	SNPB	N/A for Pkg Type	-55 to 125	5962-8769901MD A SNJ54ACT00W
SNJ54ACT00W.A	Active	Production	CFP (W) 14	25 TUBE	No	SNPB	N/A for Pkg Type	-55 to 125	5962-8769901MD A SNJ54ACT00W

⁽¹⁾ **Status:** For more details on status, see our [product life cycle](#).

⁽²⁾ **Material type:** When designated, preproduction parts are prototypes/experimental devices, and are not yet approved or released for full production. Testing and final process, including without limitation quality assurance, reliability performance testing, and/or process qualification, may not yet be complete, and this item is subject to further changes or possible discontinuation. If available for ordering, purchases will be subject to an additional waiver at checkout, and are intended for early internal evaluation purposes only. These items are sold without warranties of any kind.

⁽³⁾ **RoHS values:** Yes, No, RoHS Exempt. See the [TI RoHS Statement](#) for additional information and value definition.

⁽⁴⁾ **Lead finish/Ball material:** Parts may have multiple material finish options. Finish options are separated by a vertical ruled line. Lead finish/Ball material values may wrap to two lines if the finish value exceeds the maximum column width.

⁽⁵⁾ **MSL rating/Peak reflow:** The moisture sensitivity level ratings and peak solder (reflow) temperatures. In the event that a part has multiple moisture sensitivity ratings, only the lowest level per JEDEC standards is shown. Refer to the shipping label for the actual reflow temperature that will be used to mount the part to the printed circuit board.

⁽⁶⁾ **Part marking:** There may be an additional marking, which relates to the logo, the lot trace code information, or the environmental category of the part.

Multiple part markings will be inside parentheses. Only one part marking contained in parentheses and separated by a "-" will appear on a part. If a line is indented then it is a continuation of the previous line and the two combined represent the entire part marking for that device.

Important Information and Disclaimer: The information provided on this page represents TI's knowledge and belief as of the date that it is provided. TI bases its knowledge and belief on information provided by third parties, and makes no representation or warranty as to the accuracy of such information. Efforts are underway to better integrate information from third parties. TI has taken and continues to take reasonable steps to provide representative and accurate information but may not have conducted destructive testing or chemical analysis on incoming materials and chemicals. TI and TI suppliers consider certain information to be proprietary, and thus CAS numbers and other limited information may not be available for release.

In no event shall TI's liability arising out of such information exceed the total purchase price of the TI part(s) at issue in this document sold by TI to Customer on an annual basis.

OTHER QUALIFIED VERSIONS OF SN54ACT00, SN74ACT00 :

- Catalog : [SN74ACT00](#)

- Automotive : [SN74ACT00-Q1](#), [SN74ACT00-Q1](#)

- Military : [SN54ACT00](#)

NOTE: Qualified Version Definitions:

- Catalog - TI's standard catalog product

- Automotive - Q100 devices qualified for high-reliability automotive applications targeting zero defects

- Military - QML certified for Military and Defense Applications

TAPE AND REEL INFORMATION

QUADRANT ASSIGNMENTS FOR PIN 1 ORIENTATION IN TAPE

*All dimensions are nominal

Device	Package Type	Package Drawing	Pins	SPQ	Reel Diameter (mm)	Reel Width W1 (mm)	A0 (mm)	B0 (mm)	K0 (mm)	P1 (mm)	W (mm)	Pin1 Quadrant
SN74ACT00BQAR	WQFN	BQA	14	3000	180.0	12.4	2.8	3.3	1.1	4.0	12.0	Q1
SN74ACT00DBR	SSOP	DB	14	2000	330.0	16.4	8.35	6.6	2.4	12.0	16.0	Q1
SN74ACT00NSR	SOP	NS	14	2000	330.0	16.4	8.1	10.4	2.5	12.0	16.0	Q1
SN74ACT00PWR	TSSOP	PW	14	2000	330.0	12.4	6.9	5.6	1.6	8.0	12.0	Q1
SN74ACT00PWRG4	TSSOP	PW	14	2000	330.0	12.4	6.9	5.6	1.6	8.0	12.0	Q1

TAPE AND REEL BOX DIMENSIONS

*All dimensions are nominal

Device	Package Type	Package Drawing	Pins	SPQ	Length (mm)	Width (mm)	Height (mm)
SN74ACT00BQAR	WQFN	BQA	14	3000	210.0	185.0	35.0
SN74ACT00DBR	SSOP	DB	14	2000	353.0	353.0	32.0
SN74ACT00NSR	SOP	NS	14	2000	353.0	353.0	32.0
SN74ACT00PWR	TSSOP	PW	14	2000	353.0	353.0	32.0
SN74ACT00PWRG4	TSSOP	PW	14	2000	353.0	353.0	32.0

TUBE

*All dimensions are nominal

Device	Package Name	Package Type	Pins	SPQ	L (mm)	W (mm)	T (μm)	B (mm)
5962-8769901M2A	FK	LCCC	20	55	506.98	12.06	2030	NA
5962-8769901MDA	W	CFP	14	25	506.98	26.16	6220	NA
SN74ACT00N	N	PDIP	14	25	506	13.97	11230	4.32
SN74ACT00N	N	PDIP	14	25	506	13.97	11230	4.32
SN74ACT00N.A	N	PDIP	14	25	506	13.97	11230	4.32
SN74ACT00N.A	N	PDIP	14	25	506	13.97	11230	4.32
SN74ACT00NE4	N	PDIP	14	25	506	13.97	11230	4.32
SN74ACT00NE4	N	PDIP	14	25	506	13.97	11230	4.32
SNJ54ACT00FK	FK	LCCC	20	55	506.98	12.06	2030	NA
SNJ54ACT00FK.A	FK	LCCC	20	55	506.98	12.06	2030	NA
SNJ54ACT00W	W	CFP	14	25	506.98	26.16	6220	NA
SNJ54ACT00W.A	W	CFP	14	25	506.98	26.16	6220	NA

W (R-GDFP-F14)

CERAMIC DUAL FLATPACK

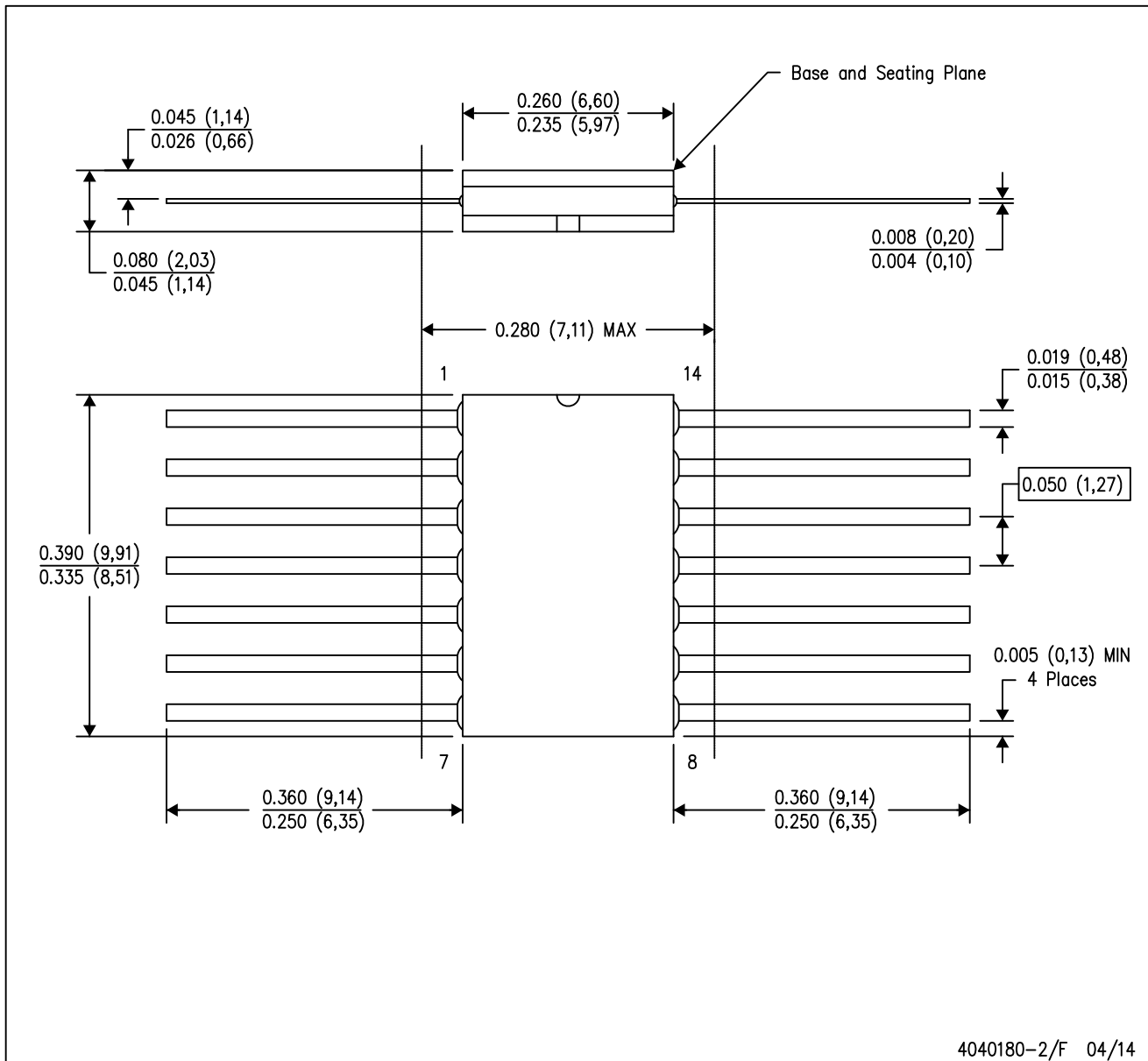

- NOTES:
- A. All linear dimensions are in inches (millimeters).
 - B. This drawing is subject to change without notice.
 - C. This package can be hermetically sealed with a ceramic lid using glass frit.
 - D. Index point is provided on cap for terminal identification only.
 - E. Falls within MIL STD 1835 GDFP1-F14

DB0014A

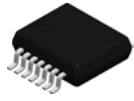

PACKAGE OUTLINE

SSOP - 2 mm max height

SMALL OUTLINE PACKAGE



NOTES:

1. All linear dimensions are in millimeters. Any dimensions in parenthesis are for reference only. Dimensioning and tolerancing per ASME Y14.5M.
2. This drawing is subject to change without notice.
3. This dimension does not include mold flash, protrusions, or gate burrs. Mold flash, protrusions, or gate burrs shall not exceed 0.15 mm per side.
4. Reference JEDEC registration MO-150.

EXAMPLE BOARD LAYOUT

DB0014A

SSOP - 2 mm max height

SMALL OUTLINE PACKAGE



LAND PATTERN EXAMPLE
EXPOSED METAL SHOWN
SCALE: 10X



4220762/A 05/2024

NOTES: (continued)

- 5. Publication IPC-7351 may have alternate designs.
- 6. Solder mask tolerances between and around signal pads can vary based on board fabrication site.

EXAMPLE STENCIL DESIGN

DB0014A

SSOP - 2 mm max height

SMALL OUTLINE PACKAGE



SOLDER PASTE EXAMPLE
BASED ON 0.125 mm THICK STENCIL
SCALE: 10X

4220762/A 05/2024

NOTES: (continued)

7. Laser cutting apertures with trapezoidal walls and rounded corners may offer better paste release. IPC-7525 may have alternate design recommendations.
8. Board assembly site may have different recommendations for stencil design.

GENERIC PACKAGE VIEW

FK 20

LCCC - 2.03 mm max height

8.89 x 8.89, 1.27 mm pitch

LEADLESS CERAMIC CHIP CARRIER

This image is a representation of the package family, actual package may vary.
Refer to the product data sheet for package details.



4229370VA\

J 14

GENERIC PACKAGE VIEW
CDIP - 5.08 mm max height
CERAMIC DUAL IN LINE PACKAGE

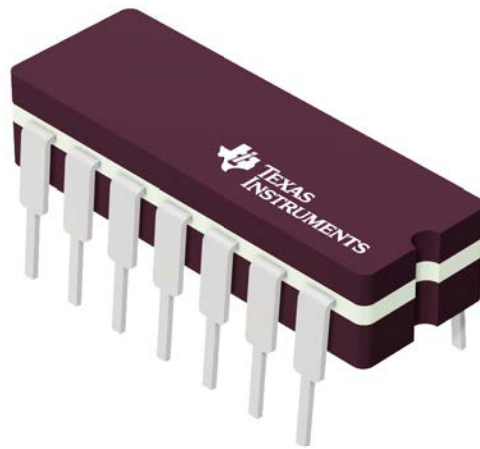

Images above are just a representation of the package family, actual package may vary.
Refer to the product data sheet for package details.

4040083-5/G

J0014A



PACKAGE OUTLINE

CDIP - 5.08 mm max height

CERAMIC DUAL IN LINE PACKAGE



NOTES:

1. All controlling linear dimensions are in inches. Dimensions in brackets are in millimeters. Any dimension in brackets or parenthesis are for reference only. Dimensioning and tolerancing per ASME Y14.5M.
2. This drawing is subject to change without notice.
3. This package is hermetically sealed with a ceramic lid using glass frit.
4. Index point is provided on cap for terminal identification only and on press ceramic glass frit seal only.
5. Falls within MIL-STD-1835 and GDIP1-T14.

EXAMPLE BOARD LAYOUT

J0014A

CDIP - 5.08 mm max height

CERAMIC DUAL IN LINE PACKAGE



LAND PATTERN EXAMPLE
NON-SOLDER MASK DEFINED
SCALE: 5X



4214771/A 05/2017

N (R-PDIP-T**)

PLASTIC DUAL-IN-LINE PACKAGE

16 PINS SHOWN



- NOTES:
- A. All linear dimensions are in inches (millimeters).
 - B. This drawing is subject to change without notice.
 - Falls within JEDEC MS-001, except 18 and 20 pin minimum body length (Dim A).
 - The 20 pin end lead shoulder width is a vendor option, either half or full width.

PW0014A



PACKAGE OUTLINE

TSSOP - 1.2 mm max height

SMALL OUTLINE PACKAGE



4220202/B 12/2023

NOTES:

1. All linear dimensions are in millimeters. Any dimensions in parenthesis are for reference only. Dimensioning and tolerancing per ASME Y14.5M.
2. This drawing is subject to change without notice.
3. This dimension does not include mold flash, protrusions, or gate burrs. Mold flash, protrusions, or gate burrs shall not exceed 0.15 mm per side.
4. This dimension does not include interlead flash. Interlead flash shall not exceed 0.25 mm per side.
5. Reference JEDEC registration MO-153.

EXAMPLE BOARD LAYOUT

PW0014A

TSSOP - 1.2 mm max height

SMALL OUTLINE PACKAGE



LAND PATTERN EXAMPLE
EXPOSED METAL SHOWN
SCALE: 10X



4220202/B 12/2023

NOTES: (continued)

- 6. Publication IPC-7351 may have alternate designs.
- 7. Solder mask tolerances between and around signal pads can vary based on board fabrication site.

EXAMPLE STENCIL DESIGN

PW0014A

TSSOP - 1.2 mm max height

SMALL OUTLINE PACKAGE



SOLDER PASTE EXAMPLE
BASED ON 0.125 mm THICK STENCIL
SCALE: 10X

4220202/B 12/2023

NOTES: (continued)

8. Laser cutting apertures with trapezoidal walls and rounded corners may offer better paste release. IPC-7525 may have alternate design recommendations.
9. Board assembly site may have different recommendations for stencil design.



D0014A

PACKAGE OUTLINE

SOIC - 1.75 mm max height

SMALL OUTLINE INTEGRATED CIRCUIT



4220718/A 09/2016

NOTES:

1. All linear dimensions are in millimeters. Dimensions in parenthesis are for reference only. Dimensioning and tolerancing per ASME Y14.5M.
2. This drawing is subject to change without notice.
3. This dimension does not include mold flash, protrusions, or gate burrs. Mold flash, protrusions, or gate burrs shall not exceed 0.15 mm, per side.
4. This dimension does not include interlead flash. Interlead flash shall not exceed 0.43 mm, per side.
5. Reference JEDEC registration MS-012, variation AB.

EXAMPLE BOARD LAYOUT

D0014A

SOIC - 1.75 mm max height

SMALL OUTLINE INTEGRATED CIRCUIT



LAND PATTERN EXAMPLE
SCALE:8X

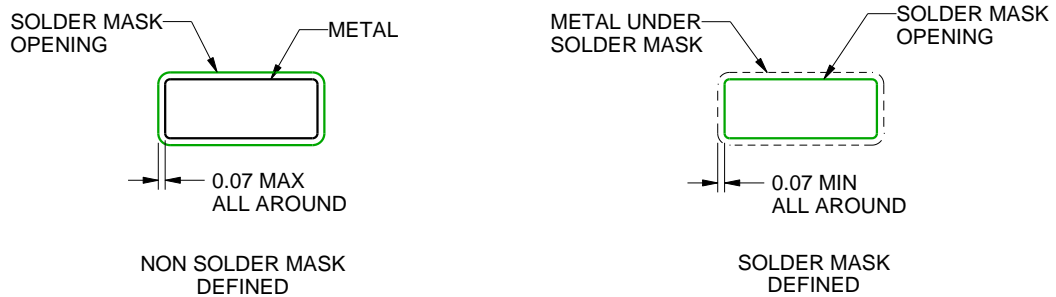

SOLDER MASK DETAILS

4220718/A 09/2016

NOTES: (continued)

- 6. Publication IPC-7351 may have alternate designs.
- 7. Solder mask tolerances between and around signal pads can vary based on board fabrication site.

EXAMPLE STENCIL DESIGN

D0014A

SOIC - 1.75 mm max height

SMALL OUTLINE INTEGRATED CIRCUIT



SOLDER PASTE EXAMPLE
BASED ON 0.125 mm THICK STENCIL
SCALE:8X

4220718/A 09/2016

NOTES: (continued)

8. Laser cutting apertures with trapezoidal walls and rounded corners may offer better paste release. IPC-7525 may have alternate design recommendations.
9. Board assembly site may have different recommendations for stencil design.

GENERIC PACKAGE VIEW

BQA 14

WQFN - 0.8 mm max height

2.5 x 3, 0.5 mm pitch

PLASTIC QUAD FLATPACK - NO LEAD

This image is a representation of the package family, actual package may vary.
Refer to the product data sheet for package details.

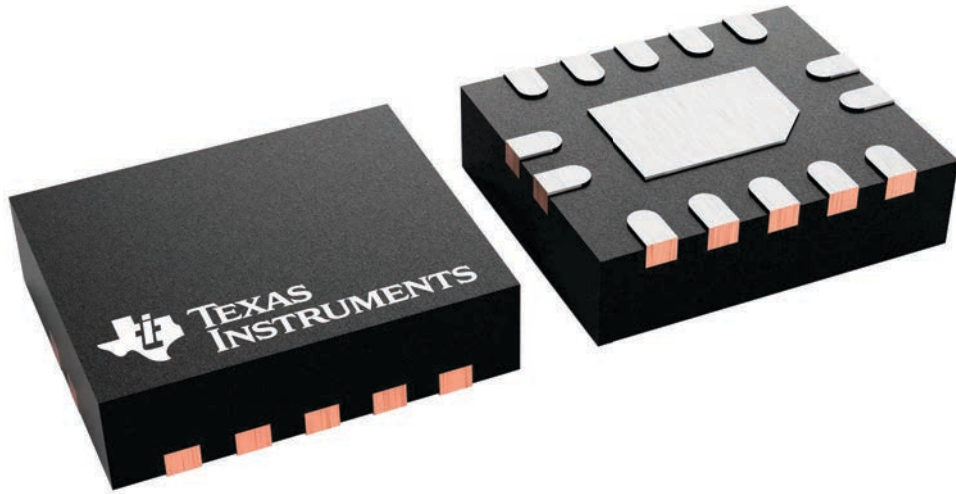

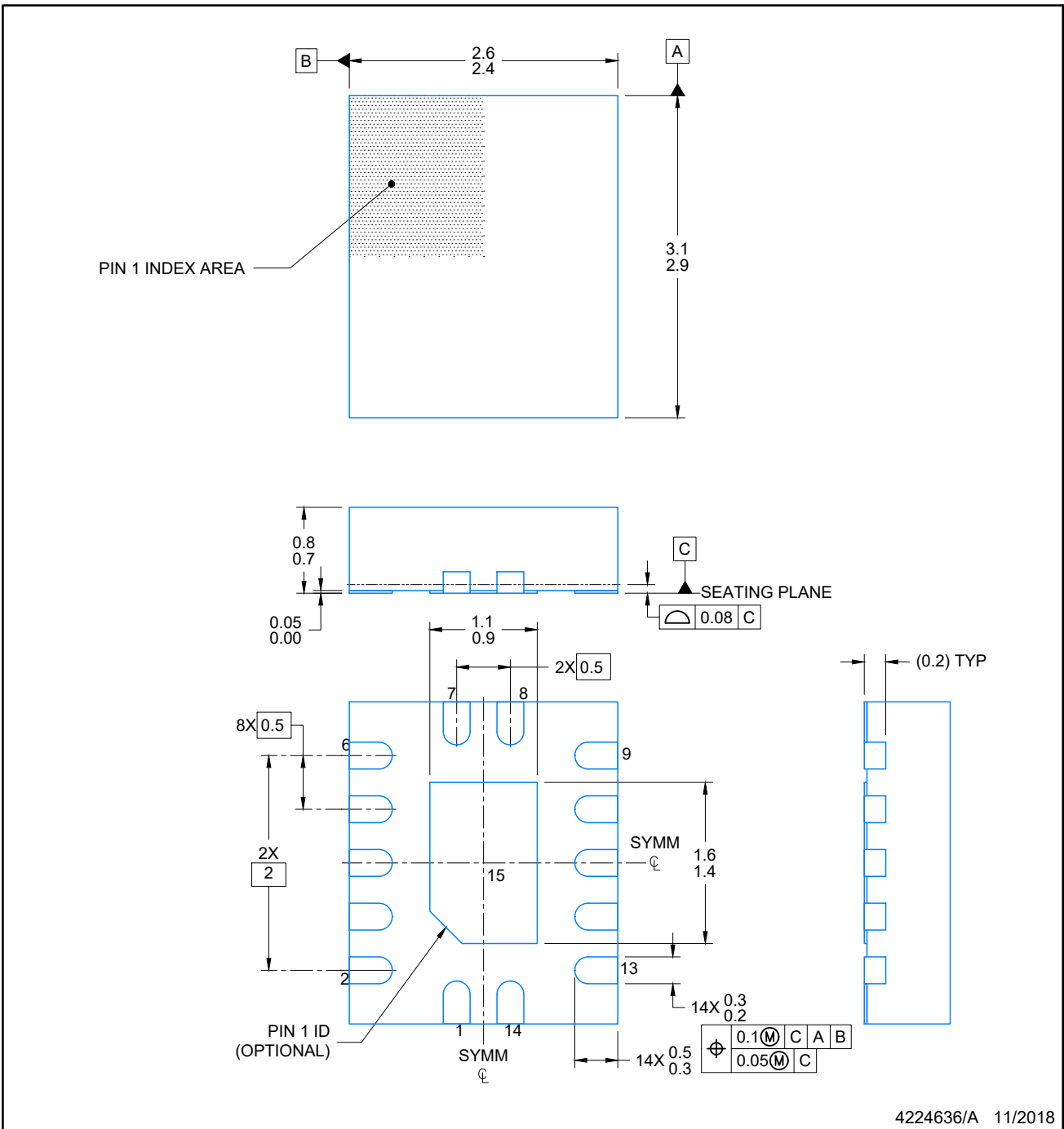

NOTES:

1. All linear dimensions are in millimeters. Any dimensions in parenthesis are for reference only. Dimensioning and tolerancing per ASME Y14.5M.
2. This drawing is subject to change without notice.
3. The package thermal pad must be soldered to the printed circuit board for optimal thermal and mechanical performance.

EXAMPLE BOARD LAYOUT

WQFN - 0.8 mm max height

BQA0014A

PLASTIC QUAD FLAT PACK-NO LEAD

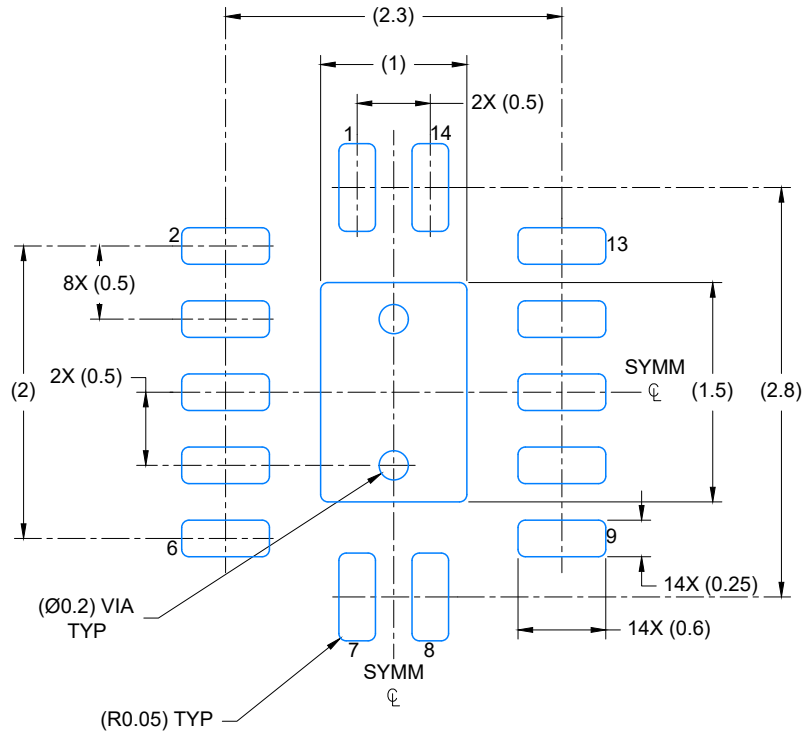

LAND PATTERN EXAMPLE
EXPOSED METAL SHOWN
SCALE: 20X

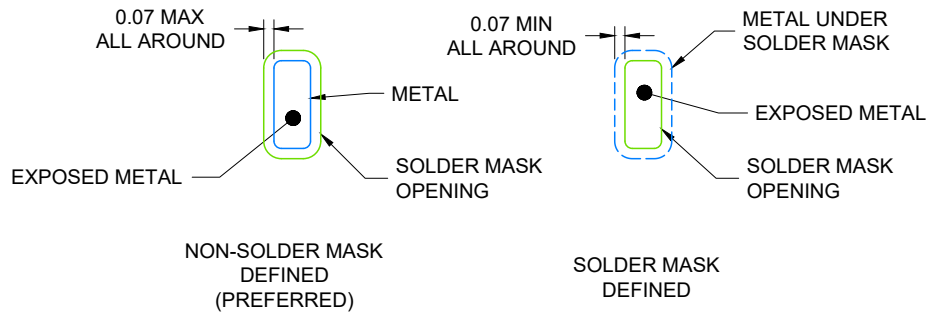

4224636/A 11/2018

NOTES: (continued)

4. This package is designed to be soldered to a thermal pad on the board. For more information, see Texas Instruments literature number SLUA271 (www.ti.com/lit/slua271).
5. Vias are optional depending on application, refer to device data sheet. If any vias are implemented, refer to their locations shown on this view. It is recommended that vias under paste be filled, plugged or tented.

EXAMPLE STENCIL DESIGN

BQA0014A

WQFN - 0.8 mm max height

PLASTIC QUAD FLAT PACK-NO LEAD

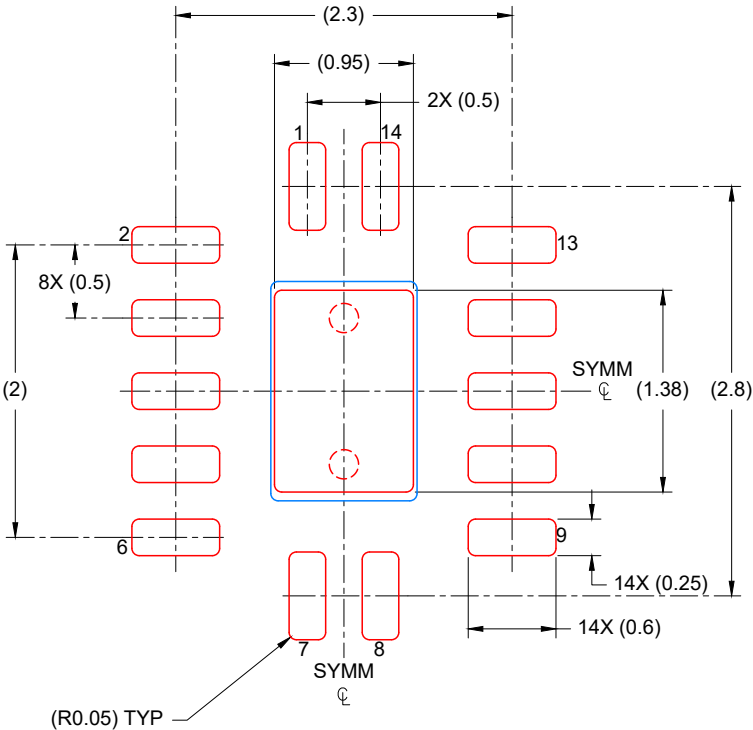

SOLDER PASTE EXAMPLE
BASED ON 0.125 mm THICK STENCIL

EXPOSED PAD
88% PRINTED COVERAGE BY AREA
SCALE: 20X

4224636/A 11/2018

NOTES: (continued)

- 6. Laser cutting apertures with trapezoidal walls and rounded corners may offer better paste release. IPC-7525 may have alternate design recommendations.

MECHANICAL DATA

NS (R-PDSO-G**)

PLASTIC SMALL-OUTLINE PACKAGE

14-PINS SHOWN



- NOTES:
- A. All linear dimensions are in millimeters.
 - B. This drawing is subject to change without notice.
 - C. Body dimensions do not include mold flash or protrusion, not to exceed 0,15.

重要通知和免责声明

TI“按原样”提供技术和可靠性数据（包括数据表）、设计资源（包括参考设计）、应用或其他设计建议、网络工具、安全信息和其他资源，不保证没有瑕疵且不做任何明示或暗示的担保，包括但不限于对适销性、与某特定用途的适用性或不侵犯任何第三方知识产权的暗示担保。

这些资源可供使用 TI 产品进行设计的熟练开发人员使用。您将自行承担以下全部责任：(1) 针对您的应用选择合适的 TI 产品，(2) 设计、验证并测试您的应用，(3) 确保您的应用满足相应标准以及任何其他安全、安保法规或其他要求。

这些资源如有变更，恕不另行通知。TI 授权您仅可将这些资源用于研发本资源所述的 TI 产品的相关应用。严禁以其他方式对这些资源进行复制或展示。您无权使用任何其他 TI 知识产权或任何第三方知识产权。对于因您对这些资源的使用而对 TI 及其代表造成的任何索赔、损害、成本、损失和债务，您将全额赔偿，TI 对此概不负责。

TI 提供的产品受 [TI 销售条款](#)、[TI 通用质量指南](#) 或 [ti.com](#) 上其他适用条款或 TI 产品随附的其他适用条款的约束。TI 提供这些资源并不会扩展或以其他方式更改 TI 针对 TI 产品发布的适用的担保或担保免责声明。除非德州仪器 (TI) 明确将某产品指定为定制产品或客户特定产品，否则其产品均为按确定价格收入目录的标准通用器件。

TI 反对并拒绝您可能提出的任何其他或不同的条款。

版权所有 © 2026，德州仪器 (TI) 公司

最后更新日期：2025 年 10 月