

SN65HVD1781A-Q1 故障保护 RS-485 收发器 (3.3V 至 5V 工作电压)

1 特性

- 符合汽车应用要求
- 具有符合 AEC-Q100 标准的下列特性
 - 器件温度等级 1：
 - 40°C 至 125°C 环境工作温度范围
 - 器件 HBM ESD 分类等级 H2
 - 器件 CDM ESG 分类等级 C3B
- 提供功能安全
 - 有助于进行功能安全系统设计的文档
- 总线引脚故障保护： $> \pm 70V$
- 3.3V 至 5V 的工作电源电压范围
- 总线引脚上的 $\pm 16kV$ HBM 保护
- 减少高达 320 个节点的单位负载
- 针对开路、短路和空闲总线情况的失效防护接收器
- 低功耗
 - 低待机电源电流： $1 \mu A$ (最大值)
 - 运行期间 $I_{CC} 4mA$ 静态电流
- 与业界通用的 SN75176 引脚兼容
- 信号传输速率高达 1Mbps

2 应用

- 信息娱乐系统，仪表组
- HMI 和显示屏
- 媒体接口
- 音响主机

3 说明

该器件被设计成在遇到过压故障 (例如电源直接短路、误接线故障、连接器故障、电缆挤压以及工具误用) 时免受损坏。它还具有高级的人体放电模型保护规格, 在静电放电 (ESD) 事件发生时依然可保持稳定。

SN65HVD1781A-Q1 将一个差动驱动器和一个差动接收器组合在一起, 这两个器件由单个电源供电。驱动器差动输出和接收器差动输入在内部进行连接, 形成适用于半双工 (双线总线) 通信的总线端口。此端口特有一个宽共模电压范围, 因此适合于长线缆运行上的多点应用。该器件的温度范围是 -40°C 至 125°C。SN65HVD1781A-Q1 器件与业界通用的 SN75176 收发器引脚兼容, 因此该器件适合大多数系统用于进行升级。

该器件采用 5V 电源时完全符合 ANSI TIA/EIA 485-A, 并且可以使用 3.3V 电源运行, 同时降低驱动器输出电压, 以适用于低功耗应用。对于需要在扩展共模电压范围内运行的应用, 请参阅 SN65HVD1785 (SLLS872) 数据表。

器件信息

器件型号	封装 ⁽¹⁾	封装尺寸 (标称值)
SN65HVD1781A-Q1	SOIC	4.90mm x 3.91mm

(1) 如需了解所有可用封装, 请参阅数据表末尾的可订购产品附录。

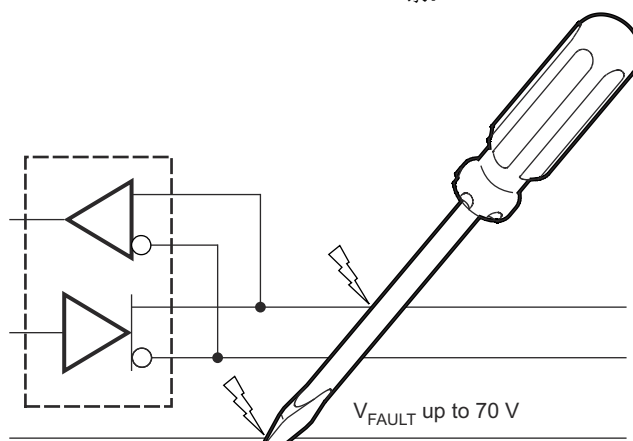

Copyright © 2016, Texas Instruments Incorporated

简化版原理图



Table of Contents

1 特性	1	8.2 Functional Block Diagram.....	13
2 应用	1	8.3 Feature Description.....	13
3 说明	1	8.4 Device Functional Modes.....	14
4 Revision History	2	9 Application and Implementation	15
5 Pin Configuration and Functions	3	9.1 Application Information.....	15
6 Specifications	4	9.2 Typical Application.....	15
6.1 Absolute Maximum Ratings.....	4	10 Power Supply Recommendations	19
6.2 ESD Ratings—AEC.....	4	11 Layout	20
6.3 ESD Ratings—IEC.....	4	11.1 Layout Guidelines.....	20
6.4 Recommended Operating Conditions.....	4	11.2 Layout Example.....	20
6.5 Thermal Information.....	5	12 Device and Documentation Support	21
6.6 Electrical Characteristics.....	6	12.1 Device Support.....	21
6.7 Power Dissipation Ratings.....	7	12.2 Documentation Support.....	21
6.8 Switching Characteristics.....	7	12.3 Receiving Notification of Documentation Updates..	21
6.9 Typical Characteristics.....	8	12.4 Community Resources.....	21
7 Parameter Measurement Information	9	12.5 Trademarks.....	21
8 Detailed Description	13	13 Mechanical, Packaging, and Orderable Information	21
8.1 Overview.....	13		

4 Revision History

注：以前版本的页码可能与当前版本的页码不同

Changes from Revision * (May 2017) to Revision A (February 2022)	Page
• 添加了特性“提供功能安全”	1

5 Pin Configuration and Functions



图 5-1. D (SOIC) Package, 8-Pin, Top View

表 5-1. Pin Functions

PIN		TYPE	DESCRIPTION
NAME	NO.		
A	6	Bus I/O	Driver output or receiver input (complementary to B)
B	7	Bus I/O	Driver output or receiver input (complementary to A)
D	4	Digital input	Driver data input
DE	3	Digital input	Driver enable, active high
GND	5	Reference potential	Local device ground
R	1	Digital output	Receive data output
RE	2	Digital input	Receiver enable, active low
V _{CC}	8	Supply	3.15-V-to-5.5-V supply

6 Specifications

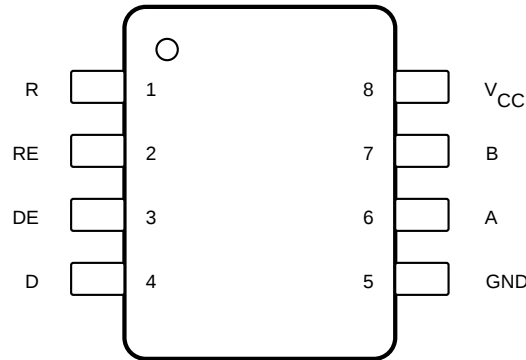
6.1 Absolute Maximum Ratings

See Note (1).

		MIN	MAX	UNIT	
V_{CC}	Supply voltage	- 0.5	7	V	
	Voltage range at bus pins	A, B pins	- 70	70	V
	Input voltage range at any logic pin	- 0.3	$V_{CC} + 0.3$	V	
	Transient overvoltage pulse through 100 Ω per TIA-485	- 70	70	V	
	Receiver output current	- 24	24	mA	
	Continuous total power dissipation	See # 6.7			
T_J	Junction temperature		170	$^{\circ}\text{C}$	
T_{stg}	Storage temperature	- 40	150	$^{\circ}\text{C}$	

(1) Stresses beyond those listed under *Absolute Maximum Ratings* may cause permanent damage to the device. These are stress ratings only and functional operation of the device at these or any other conditions beyond those indicated under *Recommended Operating Conditions* is not implied. Exposure to absolute-maximum-rated conditions for extended periods may affect device reliability.

6.2 ESD Ratings—AEC

			VALUE	UNIT	
$V_{(ESD)}$	Electrostatic discharge	Human-body model (HBM), per AEC Q100-002(1)	Bus terminals and GND	± 16000	V
			All pins	± 4000	
		Charged-device model (CDM), per AEC Q100-011		± 1500	

(1) AEC Q100-002 indicates that HBM stressing shall be in accordance with the ANSI/ESDA/JEDEC JS-001 specification.

6.3 ESD Ratings—IEC

			VALUE	UNIT	
$V_{(ESD)}$	Electrostatic discharge	Human body model (HBM), per IEC 60749-26	Bus terminals and GND	± 16000	V

6.4 Recommended Operating Conditions

		MIN	NOM	MAX	UNIT
V_{CC}	Supply voltage	3.15	5	5.5	V
V_I	Input voltage at any bus terminal (separately or common mode)(1)	- 7		12	V
V_{IH}	High-level input voltage (driver, driver enable, and receiver enable inputs)	2		V_{CC}	V
V_{IL}	Low-level input voltage (driver, driver enable, and receiver enable inputs)	0		0.8	V
V_{ID}	Differential input voltage	- 12		12	V
I_O	Output current, driver	- 60		60	mA
	Output current, receiver	- 8		8	mA
R_L	Differential load resistance	54	60		Ω
C_L	Differential load capacitance		50		pF
$1/t_{UI}$	Signaling rate			1	Mbps
T_A	Operating free-air temperature (See the # 6.5 table)	5-V supply		105	$^{\circ}\text{C}$
		3.3-V supply	- 40	125	
T_J	Junction Temperature	- 40		150	$^{\circ}\text{C}$

(1) By convention, the least positive (most negative) limit is designated as minimum in this data sheet.

6.5 Thermal Information

THERMAL METRIC ⁽¹⁾		SN65HVD1781A-Q1		
		D (SOIC)		UNIT
		8 PINS		
R _{θJA}	Junction-to-ambient thermal resistance	JEDEC high-K model	97.7	°C/W
		JEDEC low-K model	242	°C/W
R _{θJC(top)}	Junction-to-case (top) thermal resistance		39.6	°C/W
R _{θJB}	Junction-to-board thermal resistance		39.2	°C/W
ψ _{JT}	Junction-to-top characterization parameter		3.8	°C/W
ψ _{JB}	Junction-to-board characterization parameter		38.5	°C/W
R _{θJC(bot)}	Junction-to-case (bottom) thermal resistance		N/A	°C/W

- (1) For more information about traditional and new thermal metrics, see the [Semiconductor and IC Package Thermal Metrics](#) application report.

6.6 Electrical Characteristics

over recommended operating conditions (unless otherwise noted)

PARAMETER	TEST CONDITIONS		MIN	TYP	MAX	UNIT	
V _{OD}	Driver differential output voltage magnitude	R _L = 60 Ω, 4.75 V ≤ V _{CC} ≤ 375 Ω on each output to -7 V to 12 V, See Fig 7-1	T _A < 85°C	1.5		V	
			T _A < 125°C	1.4			
	R _L = 54 Ω, 4.75 V ≤ V _{CC} ≤ 5.25 V	T _A < 85°C	1.7	2			
		T _A < 125°C	1.5				
	R _L = 54 Ω, 3.15 V ≤ V _{CC} ≤ 3.45 V		0.8	1			
R _L = 100 Ω, 4.75 V ≤ V _{CC} ≤ 5.25 V	T _A < 85°C	2.2	2.5				
	T _A < 125°C	2					
Δ V _{OD}	Change in magnitude of driver differential output voltage	R _L = 54 Ω	-50	0	50	mV	
V _{OC(SS)}	Steady-state common-mode output voltage		1	V _{CC} /2	3	V	
ΔV _{OC}	Change in differential driver output common-mode voltage		-50	0	50	mV	
V _{OC(PP)}	Peak-to-peak driver common-mode output voltage	Center of two 27-Ω load resistors, See Fig 7-2		500		mV	
C _{OD}	Differential output capacitance			23		pF	
V _{IT+}	Positive-going receiver differential input voltage threshold			-100	-35	mV	
V _{IT-}	Negative-going receiver differential input voltage threshold		-180	-150		mV	
V _{HYS}	Receiver differential input voltage threshold hysteresis (V _{IT+} - V _{IT-}) ⁽¹⁾		30	50		mV	
V _{OH}	Receiver high-level output voltage	I _{OH} = -8 mA	2.4	V _{CC} - 0.3		V	
V _{OL}	Receiver low-level output voltage	I _{OL} = 8 mA	T _A < 85°C	0.2	0.4	V	
			T _A < 125°C		0.5		
I _{I(LOGIC)}	Driver input, driver enable, and receiver enable input current		-50		50	μA	
I _{OZ}	Receiver output high-impedance current	V _O = 0 V or V _{CC} , \overline{RE} at V _{CC}	-1		1	μA	
I _{OS}	Driver short-circuit output current		-200		200	mA	
I _{I(BUS)}	Bus input current (disabled driver)	V _{CC} = 3.15 to 5.5 V or V _{CC} = 0 V, DE at 0 V	V _I = 12 V	75	100	μA	
			V _I = -7 V	-60	-40		
I _{CC}	Supply current (quiescent)	Driver and receiver enabled	DE = V _{CC} , RE = GND, no load	4	6	mA	
			Driver enabled, receiver disabled	DE = V _{CC} , RE = V _{CC} , no load	3		5
			Driver disabled, receiver enabled	DE = GND, RE = GND, no load	2		4
		Driver and receiver disabled, standby mode	DE = GND, D = open, RE = V _{CC} , no load, T _A < 85°C	0.15	1	μA	
DE = GND, D = open, RE = V _{CC} , no load, T _A < 125°C			12				
Supply current (dynamic)		See the § 6.9 section					

(1) Ensured by design. Not production tested.

6.7 Power Dissipation Ratings

PARAMETER	TEST CONDITIONS	VALUE	UNIT
P _D Power dissipation	V _{CC} = 3.6 V, T _J = 150°C, R _L = 300 Ω, C _L = 50 pF (driver), C _L = 15 pF (receiver) 3.3-V supply, unterminated ⁽¹⁾	75	mW
	V _{CC} = 3.6 V, T _J = 150°C, R _L = 100 Ω, C _L = 50 pF (driver), C _L = 15 pF (receiver) 3.3-V supply, RS-422 load ⁽¹⁾	95	
	V _{CC} = 3.6 V, T _J = 150°C, R _L = 54 Ω, C _L = 50 pF (driver), C _L = 15 pF (receiver) 3.3-V supply, RS-485 load ⁽¹⁾	115	
	V _{CC} = 5.5 V, T _J = 150°C, R _L = 300 Ω, C _L = 50 pF (driver), C _L = 15 pF (receiver) 5-V supply, unterminated ⁽¹⁾	290	
	V _{CC} = 5.5 V, T _J = 150°C, R _L = 100 Ω, C _L = 50 pF (driver), C _L = 15 pF (receiver) 5-V supply, RS-422 load ⁽¹⁾	320	
	V _{CC} = 5.5 V, T _J = 150°C, R _L = 54 Ω, C _L = 50 pF (driver), C _L = 15 pF (receiver) 5-V supply, RS-485 load ⁽¹⁾	400	
T _{SD} Thermal-shutdown junction temperature		170	°C

(1) Driver and receiver enabled, 50% duty cycle square-wave signal at signaling rate: 1 Mbps.

6.8 Switching Characteristics

over recommended operating conditions (unless otherwise noted)

PARAMETER	TEST CONDITIONS	MIN	TYP	MAX	UNIT
DRIVER					
t _r , t _f Driver differential output rise/fall time	R _L = 54 Ω, C _L = 50 pF, See 图 7-3	50		300	ns
t _{PHL} , t _{PLH} Driver propagation delay	R _L = 54 Ω, C _L = 50 pF, See 图 7-3			200	ns
t _{SK(P)} Driver differential output pulse skew, t _{PHL} - t _{PLH}	R _L = 54 Ω, C _L = 50 pF, See 图 7-3			25	ns
t _{PHZ} , t _{PLZ} Driver disable time	See 图 7-4 and 图 7-5			3	μs
t _{PZH} , t _{PZL} Driver enable time	Receiver enabled			300	ns
	Receiver disabled	See 图 7-4 and 图 7-5		10	μs
RECEIVER					
t _r , t _f Receiver output rise/fall time ⁽¹⁾	C _L = 15 pF, See 图 7-6		4	15	ns
t _{PHL} , t _{PLH} Receiver propagation delay time	C _L = 15 pF, See 图 7-6		100	200	ns
t _{SK(P)} Receiver output pulse skew, t _{PHL} - t _{PLH}	C _L = 15 pF, See 图 7-6		6	20	ns
t _{PLZ} , t _{PHZ} Receiver disable time ⁽¹⁾	Driver enabled, See 图 7-7		15	100	ns
t _{PZL(1)} , t _{PZH(1)} t _{PZL(2)} , t _{PZH(2)} Receiver enable time	Driver enabled, See 图 7-7		80	300	ns
	Driver disabled, See 图 7-8		3	9	μs

(1) Specified by design. Not production tested.

6.9 Typical Characteristics



图 6-1. Driver Output Current vs Supply Voltage



图 6-2. RMS Supply Current vs Signaling Rate

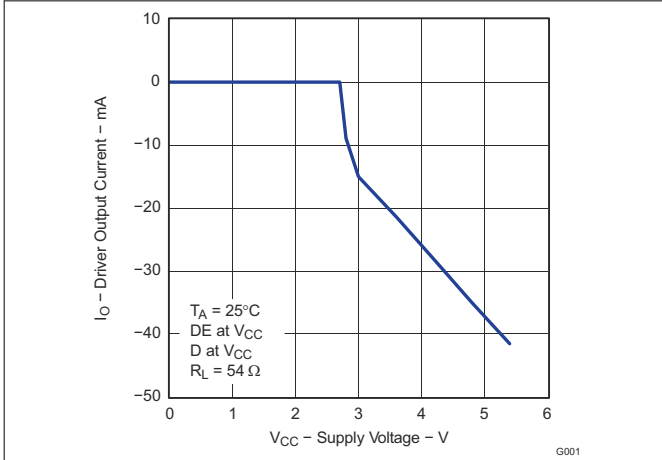

图 6-3. Differential Output Voltage vs Differential Load Current

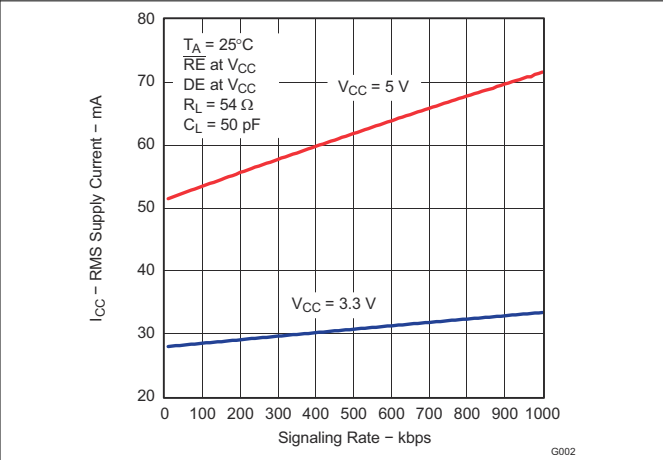

图 6-4. Rise and Fall Time

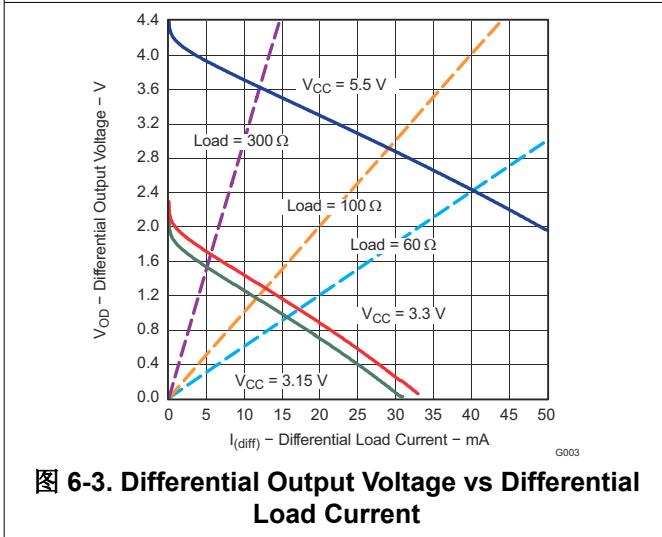

图 6-5. Differential Output Amplitude and Transition Time vs Supply Voltage

7 Parameter Measurement Information

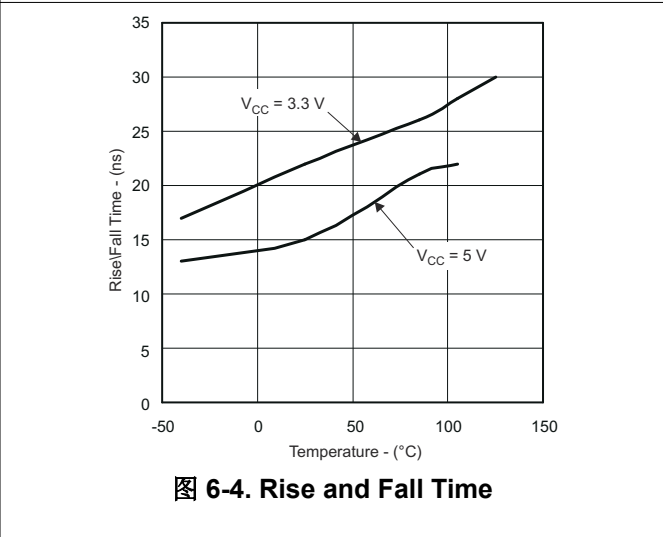
Input generator rate is 100 kbps, 50% duty cycle, rise and fall times less than 6 ns, output impedance 50 Ω.

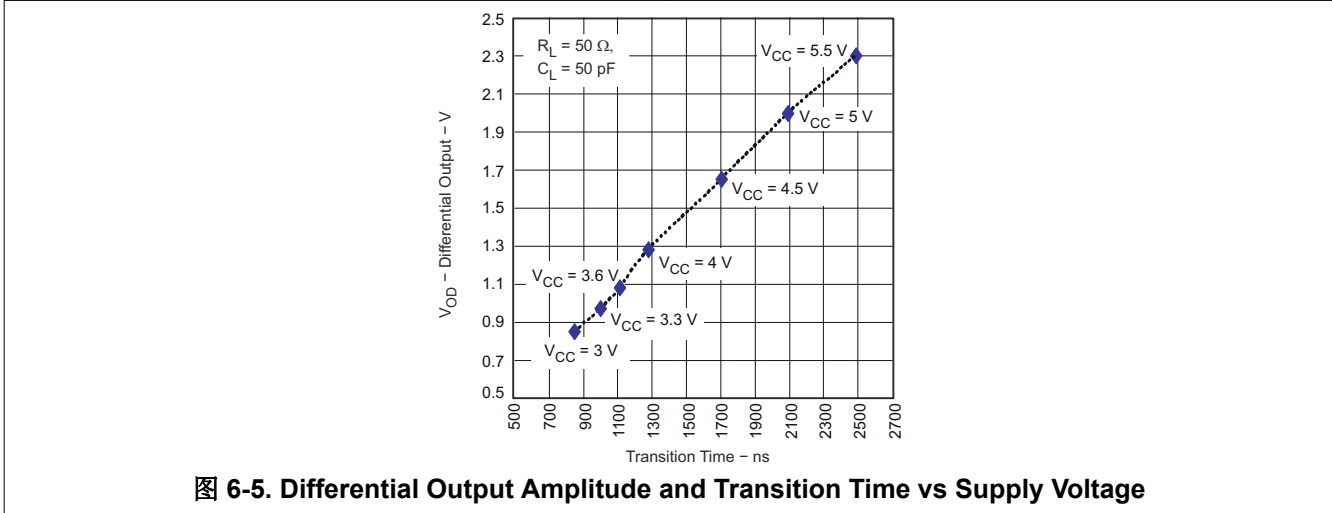

图 7-1. Measurement of Driver Differential Output Voltage With Common-Mode Load



图 7-2. Measurement of Driver Differential and Common-Mode Output With RS-485 Load

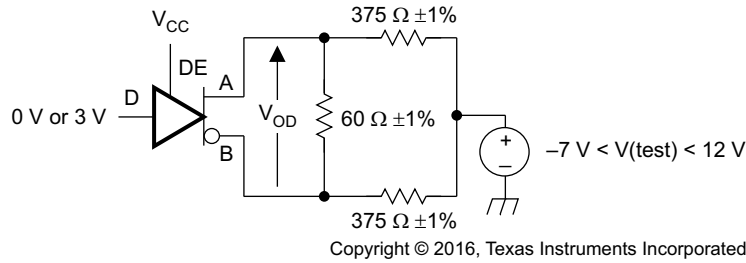

图 7-3. Measurement of Driver Differential Output Rise and Fall Times and Propagation Delays

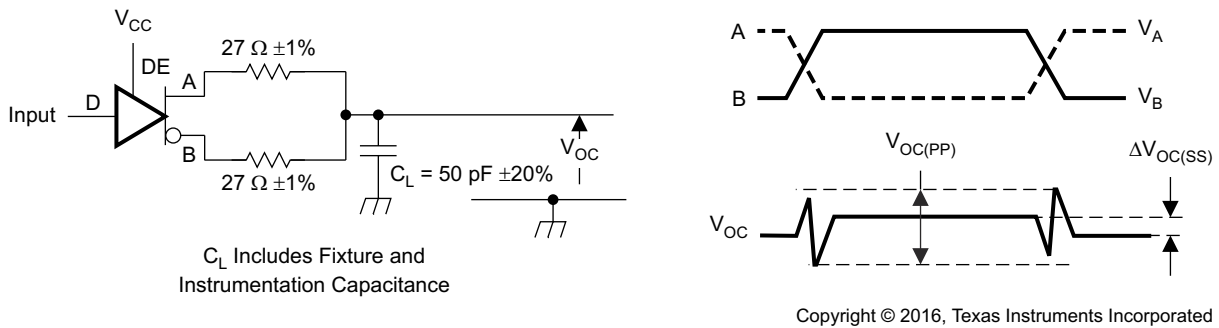

D at 3 V to test non-inverting output, D at 0 V to test inverting output.

图 7-4. Measurement of Driver Enable and Disable Times With Active High Output and Pulldown Load

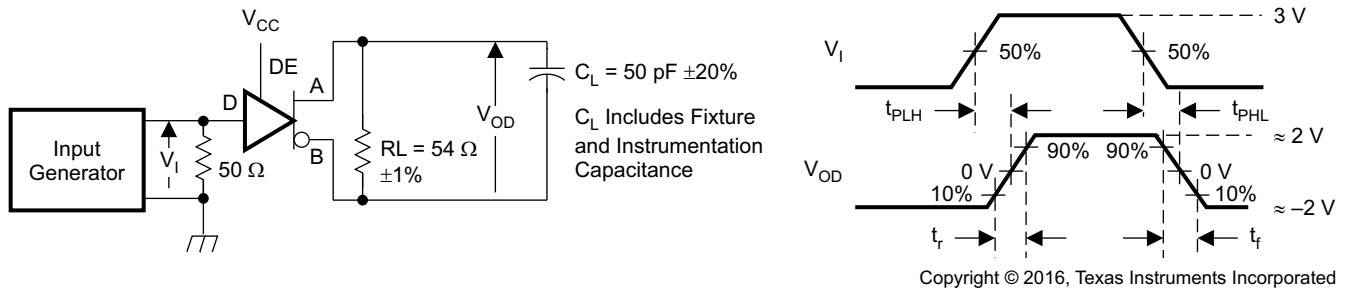
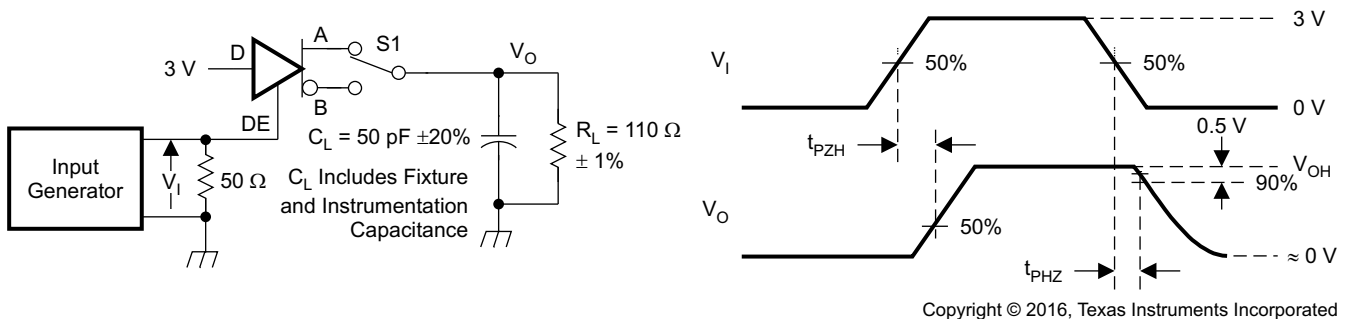
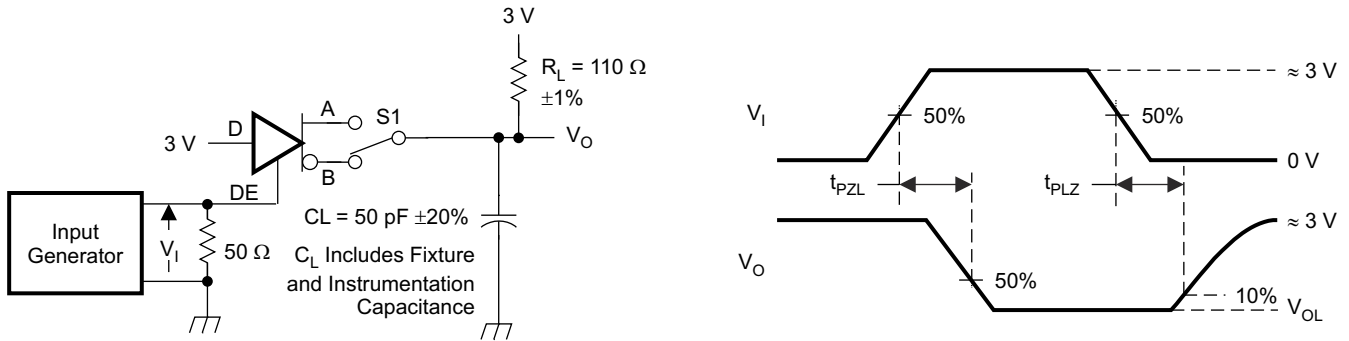

Copyright © 2016, Texas Instruments Incorporated

D at 0 V to test non-inverting output, D at 3 V to test inverting output.

图 7-5. Measurement of Driver Enable and Disable Times With Active-Low Output and Pullup Load

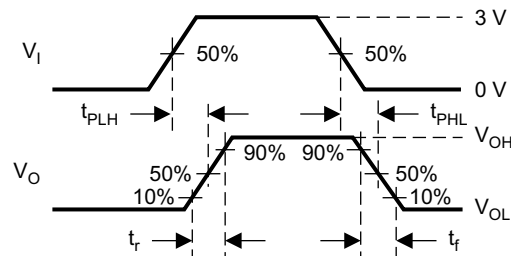
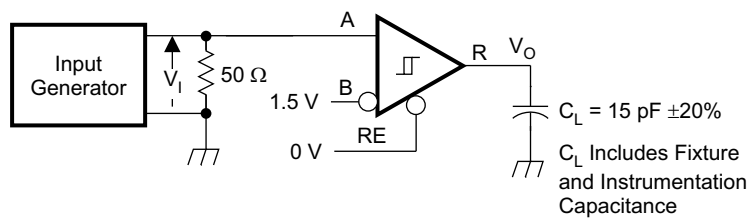

Copyright © 2016, Texas Instruments Incorporated

图 7-6. Measurement of Receiver Output Rise and Fall Times and Propagation Delays



图 7-7. Measurement of Receiver Enable and Disable Times With Driver Enabled



图 7-8. Measurement of Receiver Enable Times With Driver Disabled

8 Detailed Description

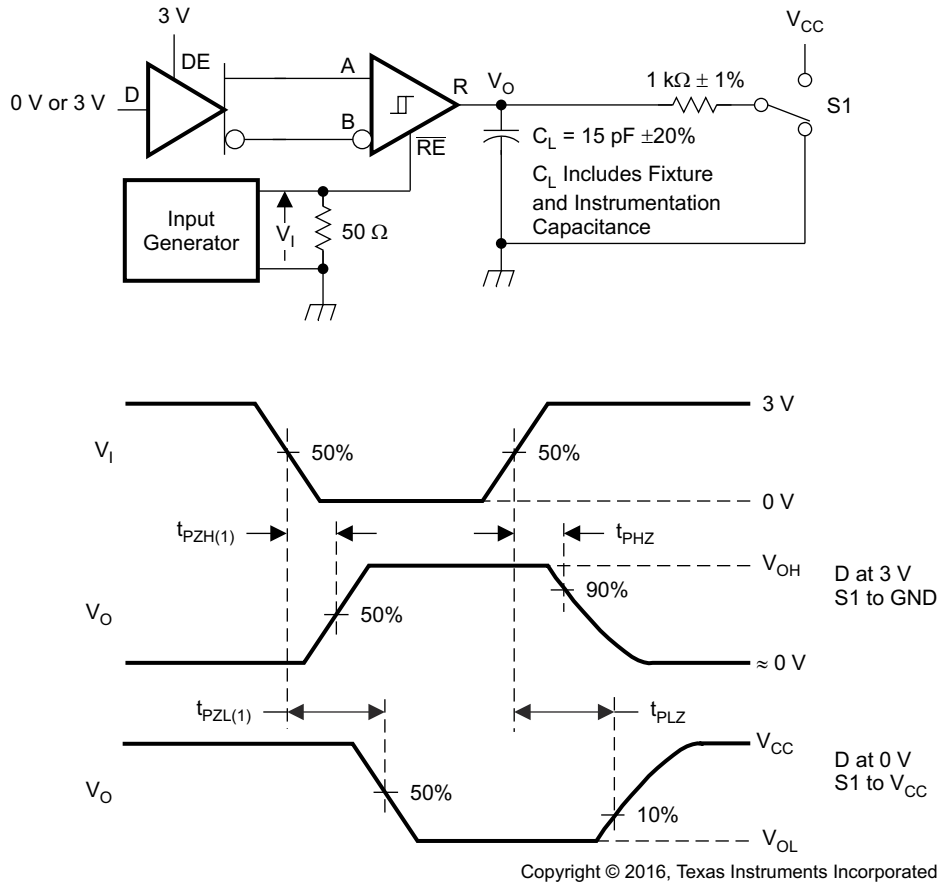
8.1 Overview

The SN65HVD1781A-Q1 is a half-duplex RS-485 transceiver that operates at data rates up to 1 Mbps.

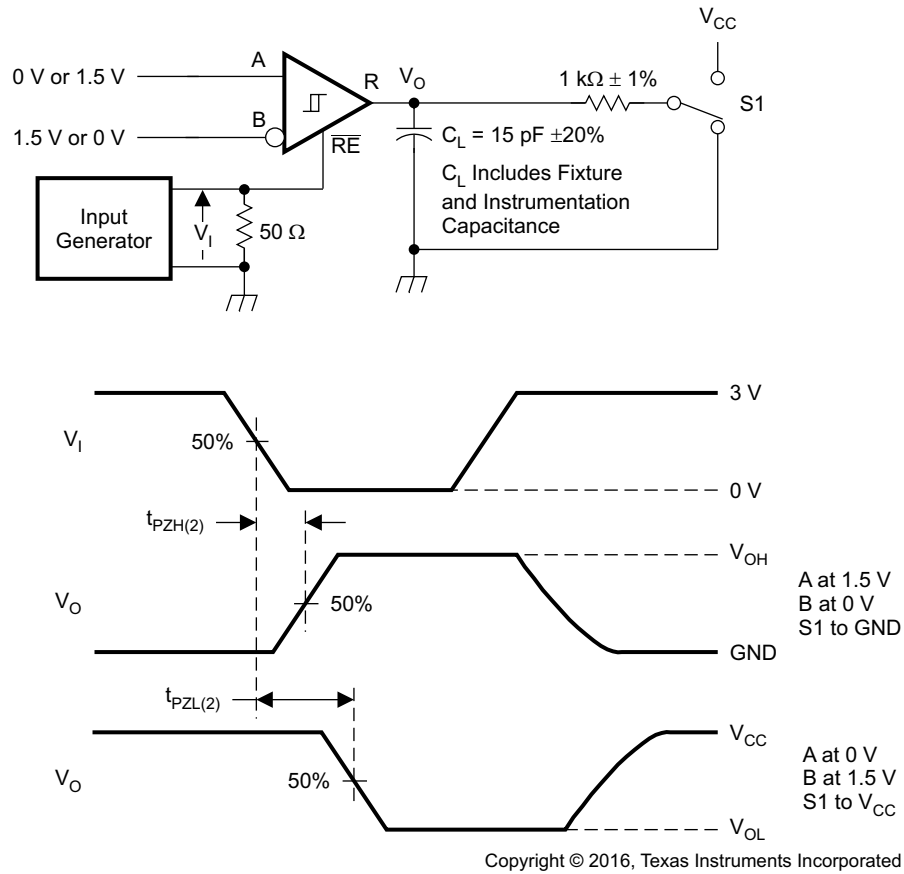
The device features a wide common-mode operating range and bus-pin fault protection up to ± 70 V. The device has an active-high driver enable and active-low receiver enable. A standby current of less than 1 μ A can be achieved by disabling both driver and receiver.

8.2 Functional Block Diagram

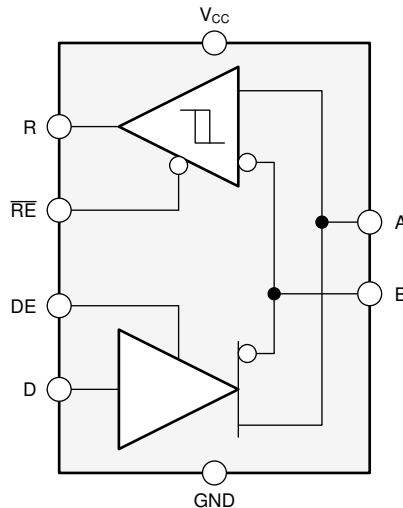

Copyright © 2016, Texas Instruments Incorporated

8.3 Feature Description

Internal ESD protection circuits protect the transceiver bus terminals against ± 16 -kV Human Body Model (HBM) electrostatic discharges.

Device operation is specified over a wide temperature range from -40°C to 125°C .

8.3.1 Receiver Failsafe

The SN65HVD1781A-Q1 half-duplex transceiver provides internal biasing of the receiver input thresholds in combination with large input-threshold hysteresis. At a positive input threshold of $V_{IT+} = -35$ mV and an input hysteresis of $V_{HYS} = 30$ mV, the receiver output remains logic high under bus-idle, bus-short, or open bus conditions in the presence of up to 130-mV_{PP} differential noise without the need for external failsafe biasing resistors.

8.3.2 Hot-Plugging

The SN65HVD1781A-Q1 is designed to operate in *hot swap* or *hot-pluggable* applications. Key features for hot-pluggable applications are power-up and power-down glitch free operation, default disabled input and output pins, and receiver failsafe.

As shown in the [Figure 8.2](#), an internal power-on reset circuit keeps the driver outputs in a high impedance state until the supply voltage has reached a level at which the device will reliably operate. This circuit ensures that no problems occur on the bus pin outputs as the power supply turns on or off.

As shown in [Figure 8.4](#), the driver and receiver enable inputs (DE and $\overline{\text{RE}}$) are disabled by default. This default ensures that the device neither drives the bus nor reports data on the R pin until the associated controller actively drives the enable pins.

8.4 Device Functional Modes

When the driver enable pin, DE, is logic high, the differential outputs A and B follow the logic states at data input D. A logic high at D causes A to turn high and B to turn low. In this case the differential output voltage defined as $V_{OD} = V_A - V_B$ is positive. When D is low, the output states reverse, B turns high, A becomes low, and V_{OD} is negative.

When DE is low, both outputs turn high-impedance. In this condition the logic state at D is irrelevant. The DE pin has an internal pull-down resistor to ground, thus when left open the driver is disabled (high-impedance) by default. The D pin has an internal pull-up resistor to V_{CC} , thus, when left open while the driver is enabled, output A turns high and B turns low.

表 8-1. Driver Function Table

INPUT D	ENABLE DE	OUTPUTS		DRIVER STATE
		A	B	
H	H	H	L	Actively drive bus High
L	H	L	H	Actively drive bus Low
X	L	Z	Z	Driver disabled
X	OPEN	Z	Z	Driver disabled by default
OPEN	H	H	L	Actively drive bus High by default

When the receiver enable pin, \overline{RE} , is logic low, the receiver is enabled. When the differential input voltage defined as $V_{ID} = V_A - V_B$ is positive and higher than the positive input threshold, V_{IT+} , the receiver output, R, turns high. When V_{ID} is negative and lower than the negative input threshold, V_{IT-} , the receiver output, R, turns low. If V_{ID} is between V_{IT+} and V_{IT-} the output is indeterminate.

When \overline{RE} is logic high or left open, the receiver output is high-impedance and the magnitude and polarity of V_{ID} are irrelevant. Internal biasing of the receiver inputs causes the output to go failsafe-high when the transceiver is disconnected from the bus (open-circuit), the bus lines are shorted (short-circuit), or the bus is not actively driven (idle bus).

表 8-2. Receiver Function Table

DIFFERENTIAL INPUT $V_{ID} = V_A - V_B$	ENABLE \overline{RE}	OUTPUT R	RECEIVER STATE
$V_{ID} > V_{IT+}$	L	H	Receive valid bus High
$V_{IT-} < V_{ID} < V_{IT+}$	L	?	Indeterminate bus state
$V_{ID} < V_{IT-}$	L	L	Receive valid bus Low
X	H	Z	Receiver disabled
X	OPEN	Z	Receiver disabled by default
Open-circuit bus	L	H	Fail-safe high output
Short-circuit bus	L	H	Fail-safe high output
Idle (terminated) bus	L	H	Fail-safe high output

9 Application and Implementation

备注

Information in the following applications sections is not part of the TI component specification, and TI does not warrant its accuracy or completeness. TI's customers are responsible for determining suitability of components for their purposes. Customers should validate and test their design implementation to confirm system functionality.

9.1 Application Information

The SN65HVD1781A-Q1 is a half-duplex RS-485 transceiver commonly used for asynchronous data transmissions. The driver and receiver enable pins allow for the configuration of different operating modes.



图 9-1. Half-Duplex Transceiver Configurations

Using independent enable lines provides the most flexible control as it allows for the driver and the receiver to be turned on and off individually. While this configuration requires two control lines, it allows for selective listening into the bus traffic, whether the driver is transmitting data or not.

Combining the enable signals simplifies the interface to the controller by forming a single direction-control signal. In this configuration, the transceiver operates as a driver when the direction-control line is high, and as a receiver when the direction-control line is low.

Additionally, only one line is required when connecting the receiver-enable input to ground and controlling only the driver-enable input. In this configuration, a node not only receives the data from the bus, but also the data it sends and can verify that the correct data have been transmitted.

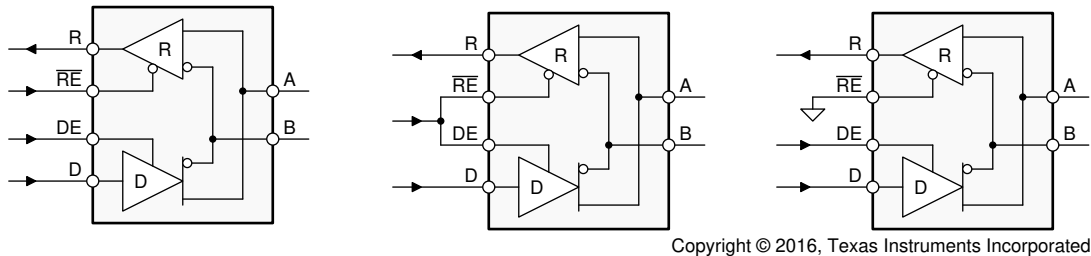
9.2 Typical Application

An RS-485 bus consists of multiple transceivers connecting in parallel to a bus cable. To eliminate line reflections, each cable end is terminated with a termination resistor, R_T , whose value matches the characteristic impedance, Z_0 , of the cable. This method, known as parallel termination, allows for higher data rates over longer cable length.

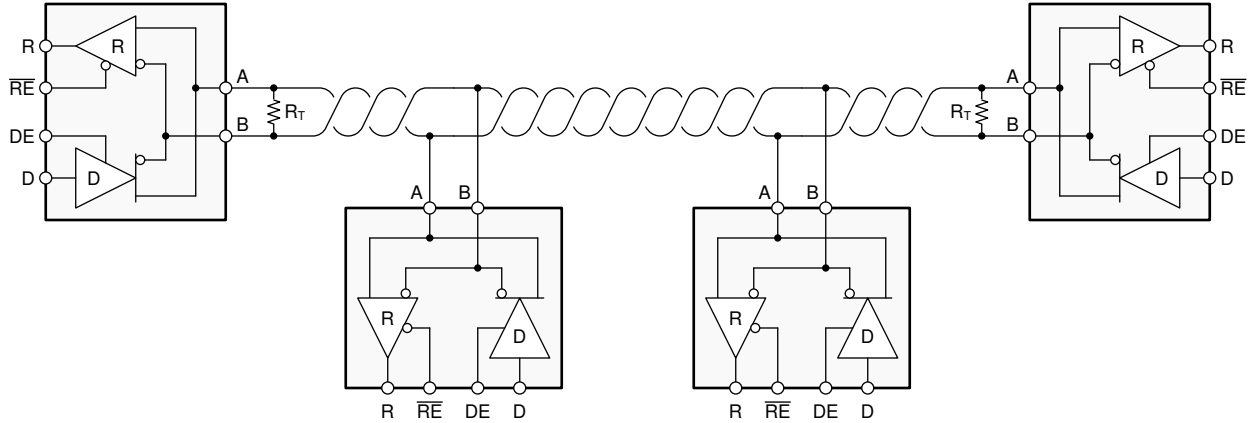

Copyright © 2016, Texas Instruments Incorporated

图 9-2. Typical RS-485 Network With Half-Duplex Transceivers

9.2.1 Design Requirements

RS-485 is a robust electrical standard suitable for long-distance networking that may be used in a wide range of applications with varying requirements, such as distance, data rate, and number of nodes.

9.2.1.1 Data Rate and Bus Length

There is an inverse relationship between data rate and bus length, meaning the higher the data rate, the shorter the cable length; and conversely, the lower the data rate, the longer the cable may be without introducing data errors. While most RS-485 systems use data rates between 10 kbps and 100 kbps, some applications require data rates up to 250 kbps at distances of 4000 feet and longer. Longer distances are possible by allowing for small signal jitter of up to 5 or 10%.





图 9-3. Cable Length vs Data Rate Characteristic

9.2.1.2 Bus Loading

The RS-485 standard specifies that a compliant driver must be able to driver 32 unit loads (UL), where 1 unit load represents a load impedance of approximately 12 kΩ. Because the SN65HVD1781A-Q1 consists of 1/10 UL transceivers, it is possible to connect up to 320 receivers to the bus.

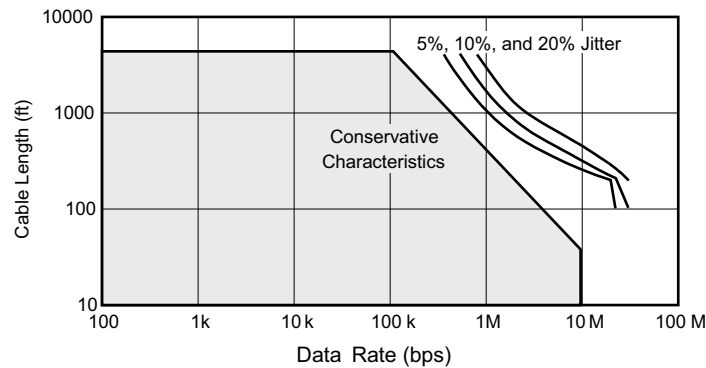
9.2.2 Detailed Design Procedure

Although the SN65HVD1781A-Q1 is internally protected against human-body-model ESD strikes up to ±16 kV, additional protection against higher-energy transients can be provided at the application level by implementing external protection devices.

 9-4 shows a protection circuit intended to withstand ±8-kV IEC ESD (per IEC 61000-4-2) as well as ±4-kV EFT (per IEC 61000-4-4).

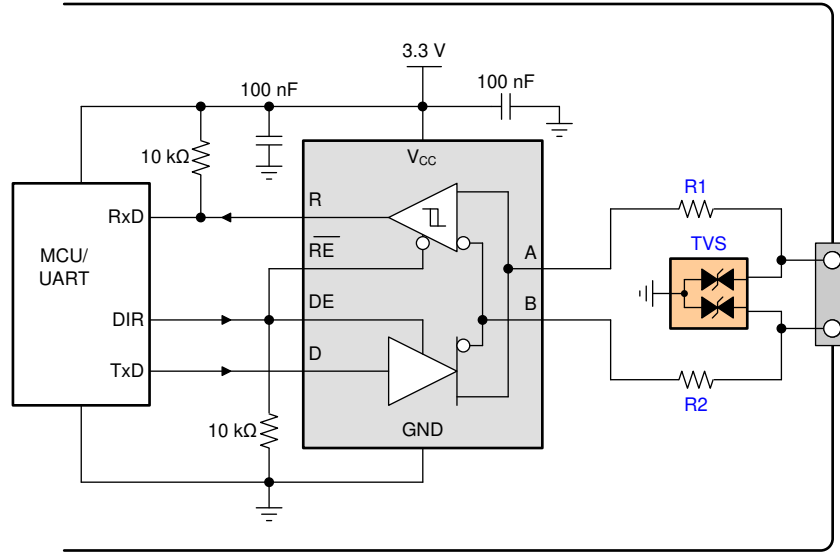

Copyright © 2016, Texas Instruments Incorporated

图 9-4. RS-485 Transceiver with External Transient Protection

表 9-1. Bill of Materials

DEVICE	FUNCTION	ORDER NUMBER	MANUFACTURER
XCVR	RS-485 Transceiver	SN65HVD1781A-Q1	TI
R1, R2	10-Ω, Pulse-Proof Thick-Film Resistor	CRCW0603010RJNEAHP	Vishay
TVS	Bidirectional 600-W Transient Suppressor	SMBJ43CA	Littelfuse

9.2.2.1 Stub Length

When connecting a node to the bus, the distance between the transceiver inputs and the cable trunk, known as the stub, should be as short as possible. Stubs present a non-terminated piece of bus line which can introduce reflections as the length of the stub increases. As a general guideline, the electrical length, or round-trip delay, of a stub should be less than one-tenth of the rise time of the driver, thus giving a maximum physical stub length as shown in 方程式 1.

$$L_{\text{stub}} \leq 0.1 \times t_r \times v \times c \quad (1)$$

where

- t_r is the 10/90 rise time of the driver
- c is the speed of light (3×10^8 m/s)
- v is the signal velocity of the cable or trace as a factor of c

9.2.2.2 Receiver Failsafe

The differential receivers of the SN65HVD1781A-Q1 has receiver input thresholds that are offset so that receiver output state is known for the following three fault conditions:

- Open bus conditions, such as a disconnected connector
- Shorted bus conditions, such as cable damage shorting the twisted-pair together
- Idle bus conditions that occur when no driver on the bus is actively driving

In any of these cases, the differential receiver will output a failsafe logic High state so that the output of the receiver is not indeterminate.

Receiver failsafe is accomplished by offsetting the receiver thresholds such that the *input indeterminate* range does not include zero volts differential. In order to comply with the RS-422 and RS-485 standards, the receiver output must output a High when the differential input V_{ID} is more positive than 200 mV, and must output a Low when V_{ID} is more negative than -200 mV. The receiver parameters which determine the failsafe performance are $V_{IT(+)}$, $V_{IT(-)}$, and V_{HYS} (the separation between $V_{IT(+)}$ and $V_{IT(-)}$). As shown in the [Table 6.6](#), differential signals more negative than -200mV will always cause a Low receiver output, and differential signals more positive than 200 mV will always cause a High receiver output.

When the differential input signal is close to zero, it is still above the maximum $V_{IT(+)}$ threshold of -35 mV, and the receiver output will be High. Only when the differential input is more than V_{HYS} below $V_{IT(+)}$ will the receiver output transition to a Low state. Therefore, the noise immunity of the receiver inputs during a bus fault condition includes the receiver hysteresis value, V_{HYS} , as well as the value of $V_{IT(+)}$.



图 9-5. Noise Immunity Under Bus Fault Conditions

9.2.3 Application Curve

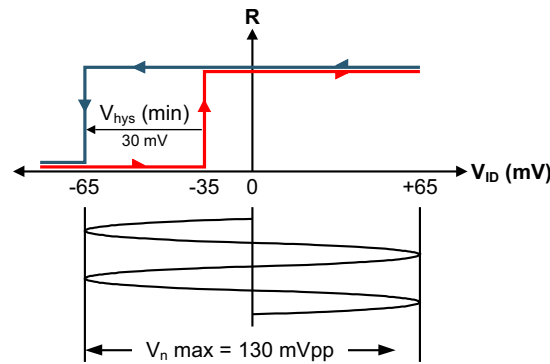
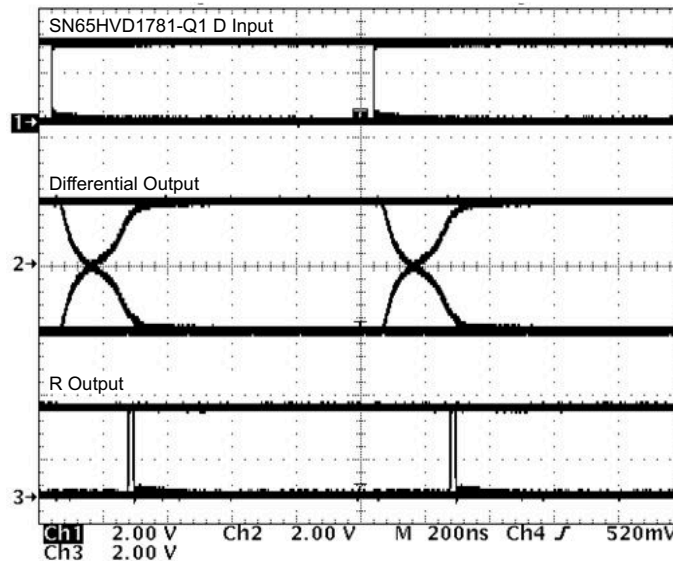

1-Mbps Operation

图 9-6. SN65HVD1781A-Q1 PRBS Data Pattern

10 Power Supply Recommendations

To ensure reliable operation at all data rates and supply voltages, each supply should be buffered with a 100-nF ceramic capacitor located as close to the supply pins as possible. The TPS7A6150-Q1 is a linear voltage regulator suitable for the 5-V supply.

11 Layout

11.1 Layout Guidelines

On-chip IEC-ESD protection is good for laboratory and portable equipment but often insufficient for EFT and surge transients occurring in industrial environments. Therefore robust and reliable bus node design requires the use of external transient protection devices.

Because ESD and EFT transients have a wide frequency bandwidth from approximately 3 MHz to 3 GHz, high-frequency layout techniques must be applied during PCB design.

1. Place the protection circuitry close to the bus connector to prevent noise transients from entering the board.
2. Use V_{CC} and ground planes to provide low-inductance. High-frequency currents follow the path of least inductance and not the path of least impedance.
3. Design the protection components into the direction of the signal path. Do not force the transient currents to divert from the signal path to reach the protection device.
4. Apply 100-nF to 220-nF bypass capacitors as close as possible to the V_{CC} pins of the transceiver, UART, or controller ICs on the board.
5. Use at least two vias for V_{CC} and ground connections of bypass capacitors and protection devices to minimize effective via inductance.
6. Use 1-k Ω to 10-k Ω pullup and pulldown resistors for enable lines to limit noise currents in these lines during transient events.
7. While pure TVS protection is sufficient for surge transients up to 1 kV, higher transients require metal-oxide varistors (MOVs) which reduce the transients to a few hundred volts of clamping voltage, and transient blocking units (TBUs) that limit transient current to less than 1 mA.

11.2 Layout Example



图 11-1. Half-Duplex Layout Example

12 Device and Documentation Support

12.1 Device Support

12.2 Documentation Support

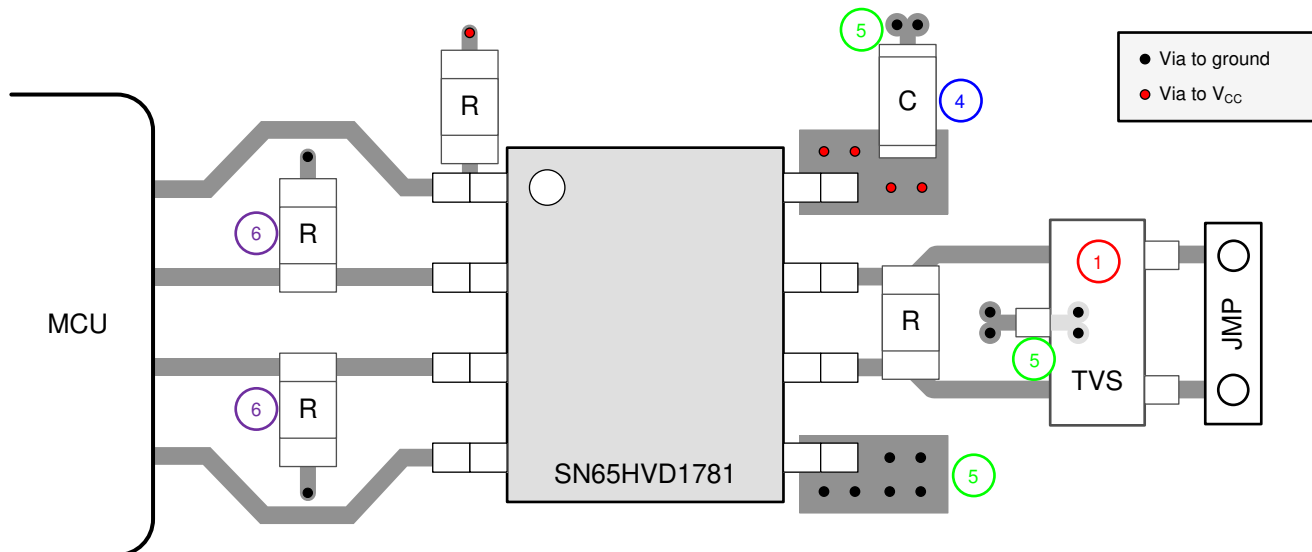
12.2.1 Related Documentation

For related documentation see the following:

- [RS-485 Half-Duplex Evaluation Module](#)
- [SN65HVD17xx Fault-Protected RS-485 Transceivers With Extended Common-Mode Range](#)
- [TPS7A6xxx-Q1 300-mA 40-V Low-Dropout Regulator With 25- \$\mu\$ A Quiescent Current](#)

12.3 Receiving Notification of Documentation Updates

To receive notification of documentation updates, navigate to the device product folder on ti.com. In the upper right corner, click on *Alert me* to register and receive a weekly digest of any product information that has changed. For change details, review the revision history included in any revised document.

12.4 Community Resources

12.5 Trademarks

所有商标均为其各自所有者的财产。

13 Mechanical, Packaging, and Orderable Information

The following pages include mechanical, packaging, and orderable information. This information is the most current data available for the designated devices. This data is subject to change without notice and revision of this document. For browser-based versions of this data sheet, refer to the left-hand navigation.

PACKAGING INFORMATION

Orderable part number	Status (1)	Material type (2)	Package Pins	Package qty Carrier	RoHS (3)	Lead finish/ Ball material (4)	MSL rating/ Peak reflow (5)	Op temp (°C)	Part marking (6)
SN65HVD1781AQDRQ1	Active	Production	SOIC (D) 8	2500 LARGE T&R	Yes	NIPDAU	Level-1-260C-UNLIM	-40 to 125	1781AQ
SN65HVD1781AQDRQ1.A	Active	Production	SOIC (D) 8	2500 LARGE T&R	Yes	NIPDAU	Level-1-260C-UNLIM	-40 to 125	1781AQ

(1) **Status:** For more details on status, see our [product life cycle](#).

(2) **Material type:** When designated, preproduction parts are prototypes/experimental devices, and are not yet approved or released for full production. Testing and final process, including without limitation quality assurance, reliability performance testing, and/or process qualification, may not yet be complete, and this item is subject to further changes or possible discontinuation. If available for ordering, purchases will be subject to an additional waiver at checkout, and are intended for early internal evaluation purposes only. These items are sold without warranties of any kind.

(3) **RoHS values:** Yes, No, RoHS Exempt. See the [TI RoHS Statement](#) for additional information and value definition.

(4) **Lead finish/Ball material:** Parts may have multiple material finish options. Finish options are separated by a vertical ruled line. Lead finish/Ball material values may wrap to two lines if the finish value exceeds the maximum column width.

(5) **MSL rating/Peak reflow:** The moisture sensitivity level ratings and peak solder (reflow) temperatures. In the event that a part has multiple moisture sensitivity ratings, only the lowest level per JEDEC standards is shown. Refer to the shipping label for the actual reflow temperature that will be used to mount the part to the printed circuit board.

(6) **Part marking:** There may be an additional marking, which relates to the logo, the lot trace code information, or the environmental category of the part.

Multiple part markings will be inside parentheses. Only one part marking contained in parentheses and separated by a "~" will appear on a part. If a line is indented then it is a continuation of the previous line and the two combined represent the entire part marking for that device.

Important Information and Disclaimer:The information provided on this page represents TI's knowledge and belief as of the date that it is provided. TI bases its knowledge and belief on information provided by third parties, and makes no representation or warranty as to the accuracy of such information. Efforts are underway to better integrate information from third parties. TI has taken and continues to take reasonable steps to provide representative and accurate information but may not have conducted destructive testing or chemical analysis on incoming materials and chemicals. TI and TI suppliers consider certain information to be proprietary, and thus CAS numbers and other limited information may not be available for release.

In no event shall TI's liability arising out of such information exceed the total purchase price of the TI part(s) at issue in this document sold by TI to Customer on an annual basis.



D0008A

PACKAGE OUTLINE

SOIC - 1.75 mm max height

SMALL OUTLINE INTEGRATED CIRCUIT



4214825/C 02/2019

NOTES:

1. Linear dimensions are in inches [millimeters]. Dimensions in parenthesis are for reference only. Controlling dimensions are in inches. Dimensioning and tolerancing per ASME Y14.5M.
2. This drawing is subject to change without notice.
3. This dimension does not include mold flash, protrusions, or gate burrs. Mold flash, protrusions, or gate burrs shall not exceed $.006$ [0.15] per side.
4. This dimension does not include interlead flash.
5. Reference JEDEC registration MS-012, variation AA.

EXAMPLE BOARD LAYOUT

D0008A

SOIC - 1.75 mm max height

SMALL OUTLINE INTEGRATED CIRCUIT



LAND PATTERN EXAMPLE
EXPOSED METAL SHOWN
SCALE:8X



SOLDER MASK DETAILS

4214825/C 02/2019

NOTES: (continued)

- 6. Publication IPC-7351 may have alternate designs.
- 7. Solder mask tolerances between and around signal pads can vary based on board fabrication site.

EXAMPLE STENCIL DESIGN

D0008A

SOIC - 1.75 mm max height

SMALL OUTLINE INTEGRATED CIRCUIT



SOLDER PASTE EXAMPLE
BASED ON .005 INCH [0.125 MM] THICK STENCIL
SCALE:8X

4214825/C 02/2019

NOTES: (continued)

8. Laser cutting apertures with trapezoidal walls and rounded corners may offer better paste release. IPC-7525 may have alternate design recommendations.
9. Board assembly site may have different recommendations for stencil design.

重要通知和免责声明

TI“按原样”提供技术和可靠性数据（包括数据表）、设计资源（包括参考设计）、应用或其他设计建议、网络工具、安全信息和其他资源，不保证没有瑕疵且不做任何明示或暗示的担保，包括但不限于对适销性、与某特定用途的适用性或不侵犯任何第三方知识产权的暗示担保。

这些资源可供使用 TI 产品进行设计的熟练开发人员使用。您将自行承担以下全部责任：(1) 针对您的应用选择合适的 TI 产品，(2) 设计、验证并测试您的应用，(3) 确保您的应用满足相应标准以及任何其他安全、安保法规或其他要求。

这些资源如有变更，恕不另行通知。TI 授权您仅可将这些资源用于研发本资源所述的 TI 产品的相关应用。严禁以其他方式对这些资源进行复制或展示。您无权使用任何其他 TI 知识产权或任何第三方知识产权。对于因您对这些资源的使用而对 TI 及其代表造成的任何索赔、损害、成本、损失和债务，您将全额赔偿，TI 对此概不负责。

TI 提供的产品受 [TI 销售条款](#)、[TI 通用质量指南](#) 或 [ti.com](#) 上其他适用条款或 TI 产品随附的其他适用条款的约束。TI 提供这些资源并不会扩展或以其他方式更改 TI 针对 TI 产品发布的适用的担保或担保免责声明。除非德州仪器 (TI) 明确将某产品指定为定制产品或客户特定产品，否则其产品均为按确定价格收入目录的标准通用器件。

TI 反对并拒绝您可能提出的任何其他或不同的条款。

版权所有 © 2025，德州仪器 (TI) 公司

最后更新日期：2025 年 10 月