

# 共模范围为 $-15\text{V}$ 至 $80\text{V}$ 的 INA901-SP 耐辐射 单向电流分流监控器

## 1 特性

- 5962-1821001
  - 在低剂量率下的耐辐射 (RHA) 剂量为  $100\text{krad}(\text{Si})$
  - 单粒子门锁 (SEL) 在  $125^\circ\text{C}$  下的抗扰度可达  $93\text{MeV}\cdot\text{cm}^2/\text{mg}$ 
    - 请参阅[辐射报告](#)
  - 符合军用级温度范围要求 ( $-55^\circ\text{C}$  至  $125^\circ\text{C}$ )
  - 高性能 8 引脚陶瓷扁平封装 (HKX)
- 宽共模范围:  $-15\text{V}$  至  $80\text{V}$
- CMRR:  $120\text{dB}$
- 精度:
  - $\pm 0.5\text{mV}$  的失调电压
  - $\pm 0.2\%$  增益误差
  - $2.5\mu\text{V}/^\circ\text{C}$  的温漂
  - $50\text{ppm}/^\circ\text{C}$  的增益漂移
- 带宽: 高达  $130\text{kHz}$
- 增益:  $20\text{V}/\text{V}$
- 静态电流:  $700\mu\text{A}$
- 电源电压:  $2.7\text{V}$  至  $16\text{V}$
- 可用于滤波

## 2 应用

- 电源监控
- 过流和欠流检测
- 卫星遥测
- 空间信号调节
- 电机控制环路

## 3 说明

INA901-SP 是一款电压输出、电流检测放大器，可在独立于电源电压的  $-15\text{V}$  至  $+80\text{V}$  共模电压中感应分流电阻上的压降。INA901-SP 由  $2.7\text{V}$  至  $16\text{V}$  单电源供电，消耗的电源电流为  $700\mu\text{A}$ （典型值）。

INA901-SP 的增益为  $20\text{V}/\text{V}$ 。  $130\text{kHz}$  带宽简化了在电流控制环路中的使用。其引脚排列可充分支持滤波。

该器件具有  $-55^\circ\text{C}$  至  $+125^\circ\text{C}$  的扩展额定工作温度范围，并且采用 8 引脚 CFP 封装。

器件信息<sup>(1)</sup>

器件型号	等级	封装
5962R1821001VXC	QMLV RHA [100 krad(Si)]	8 引线 CFP [HKX] 6.48 × 6.48mm 重量: 0.39g <sup>(3)</sup>
5962-1821001VXC	QMLV	
INA901HKX/EM	工程样片 <sup>(2)</sup>	—
INA901EVM-CVAL	陶瓷评估板	—

(1) 如需了解所有可用封装，请参阅数据表末尾的可订购产品附录。

(2) 这些部件仅适用于工程评估。部件按照不合规的流程进行加工处理。这些部件不适用于质检、生产、辐射测试或飞行。这些零部件无法在  $-55^\circ\text{C}$  至  $125^\circ\text{C}$  的完整 MIL 额定温度范围内或运行寿命中保证其性能。

(3) 重量误差在  $\pm 10\%$  以内。

简化原理图

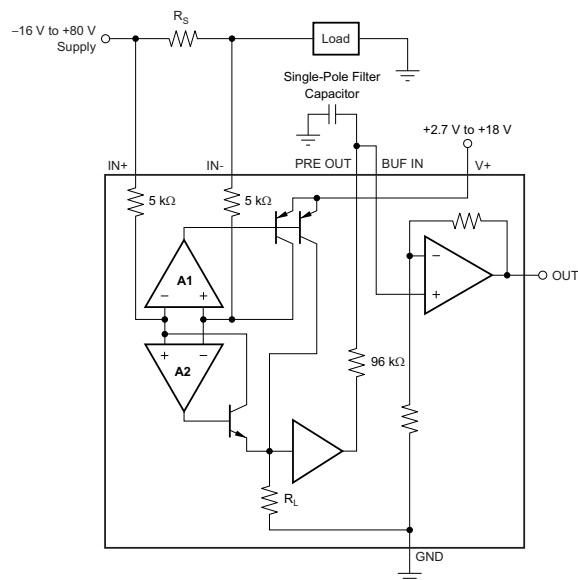

## 目录

<b>1</b>	特性 .....	<b>1</b>	7.4	Device Functional Modes .....	<b>13</b>
<b>2</b>	应用 .....	<b>1</b>	<b>8</b>	<b>Application and Implementation</b> .....	<b>16</b>
<b>3</b>	说明 .....	<b>1</b>	8.1	Application Information .....	<b>16</b>
<b>4</b>	修订历史记录 .....	<b>2</b>	8.2	Typical Application .....	<b>16</b>
<b>5</b>	<b>Pin Configuration and Functions</b> .....	<b>3</b>	<b>9</b>	<b>Power Supply Recommendations</b> .....	<b>18</b>
<b>6</b>	<b>Specifications</b> .....	<b>3</b>	<b>10</b>	<b>Layout</b> .....	<b>19</b>
6.1	Absolute Maximum Ratings .....	<b>3</b>	10.1	Layout Guidelines .....	<b>19</b>
6.2	ESD Ratings .....	<b>3</b>	10.2	Layout Example .....	<b>19</b>
6.3	Recommended Operating Conditions .....	<b>4</b>	<b>11</b>	器件和文档支持 .....	<b>20</b>
6.4	Thermal Information .....	<b>4</b>	11.1	文档支持 .....	<b>20</b>
6.5	Electrical Characteristics .....	<b>5</b>	11.2	接收文档更新通知 .....	<b>20</b>
6.6	Quality Conformance Inspection .....	<b>6</b>	11.3	社区资源 .....	<b>20</b>
6.7	Typical Characteristics .....	<b>7</b>	11.4	商标 .....	<b>20</b>
<b>7</b>	<b>Detailed Description</b> .....	<b>10</b>	11.5	静电放电警告 .....	<b>20</b>
7.1	Overview .....	<b>10</b>	11.6	术语表 .....	<b>20</b>
7.2	Functional Block Diagram .....	<b>10</b>	<b>12</b>	机械、封装和可订购信息 .....	<b>21</b>
7.3	Feature Description .....	<b>11</b>			

## 4 修订历史记录

注：之前版本的页码可能与当前版本有所不同。

<b>Changes from Revision A (December 2018) to Revision B</b>	<b>Page</b>
• 已更改 将器件状态从 <b>预告信息</b> 更改为 <b>生产数据</b> .....	<b>1</b>

## 5 Pin Configuration and Functions

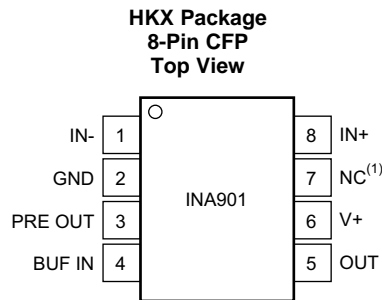

NOTE (1): NC denotes no internal connection.

### Pin Functions

PIN		I/O	TYPE <sup>(1)</sup>	DESCRIPTION
NAME	NO.			
BUF IN	4	I	A	Connect to output of filter from PRE OUT.
GND	2	—	GND	Ground.
IN-	1	I	A	Connect to load side of shunt resistor.
IN+	8	I	A	Connect to supply side of shunt resistor.
NC	7	—	—	Recommend connect to ground.
OUT	5	O	A	Output voltage.
PRE OUT	3	O	A	Connect to input of filter to BUF IN.
V+	6	—	P	Power supply, 2.7 V to 18 V.

(1) A = analog, P = power, GND = ground

## 6 Specifications

### 6.1 Absolute Maximum Ratings<sup>(1)</sup>

	MIN	MAX	UNIT	
Supply voltage ( $V_S$ )		18	V	
Analog inputs, $V_{IN+}$ , $V_{IN-}$	Differential, $(V_{IN+}) - (V_{IN-})$	-18	18	V
	Common-mode	-16	80	
Analog output: OUT and PRE OUT pins	GND - 0.3	(V+) + 0.3	V	
Input current into any pin		5	mA	
Operating temperature	-55	150	°C	
Junction temperature		150	°C	
Storage temperature, $T_{stg}$	-65	150	°C	

(1) Stresses beyond those listed under *Absolute Maximum Ratings* may cause permanent damage to the device. These are stress ratings only, which do not imply functional operation of the device at these or any other conditions beyond those indicated under *Recommended Operating Conditions*. Exposure to absolute-maximum-rated conditions for extended periods may affect device reliability.

### 6.2 ESD Ratings

	VALUE	UNIT
$V_{(ESD)}$ Electrostatic discharge	Human-body model (HBM), per ANSI/ESDA/JEDEC JS-001 <sup>(1)</sup>	±3000
	Charged-device model (CDM), per JEDEC specification JESD22-C101 <sup>(2)</sup>	±1000

(1) JEDEC document JEP155 states that 500-V HBM allows safe manufacturing with a standard ESD control process.

(2) JEDEC document JEP157 states that 250-V CDM allows safe manufacturing with a standard ESD control process.

### 6.3 Recommended Operating Conditions

over operating free-air temperature range (unless otherwise noted)

		MIN	MAX	UNIT
$V_{CM}$	Common-mode input voltage	-15	80	V
$V_S$	Operating supply voltage	2.7	16	V
$T_A$	Operating free-air temperature	-55	125	°C

### 6.4 Thermal Information

THERMAL METRIC <sup>(1)</sup>		INA901-SP	UNIT
		HKX (CFP)	
		8 PINS	
$R_{\theta JA}$	Junction-to-ambient thermal resistance	116.7	°C/W
$R_{\theta JC(top)}$	Junction-to-case (top) thermal resistance	39.1	°C/W
$R_{\theta JB}$	Junction-to-board thermal resistance	98.8	°C/W
$\Psi_{JT}$	Junction-to-top characterization parameter	32.5	°C/W
$\Psi_{JB}$	Junction-to-board characterization parameter	93.1	°C/W
$R_{\theta JC(bot)}$	Junction-to-case (bottom) thermal resistance	26.5	°C/W

(1) For more information about traditional and new thermal metrics, see the [Semiconductor and IC Package Thermal Metrics](#) application report.

## 6.5 Electrical Characteristics

$V_S = 2.7\text{ V}$  and  $16\text{ V}$ ,  $V_{CM} = -15\text{ V}$ ,  $12\text{ V}$  and  $80\text{ V}$ ,  $V_{SENSE} = 100\text{ mV}$ , and PRE OUT connected to BUF IN, unless otherwise noted.  $T_A$  is as shown in SUBGROUP column.

PARAMETER		TEST CONDITIONS	SUBGROUP <sup>(1)</sup>	MIN	TYP	MAX	UNIT
<b>INPUT</b>							
$V_{SENSE}$	Full-scale input voltage	$V_{SENSE} = (V_{IN+}) - (V_{IN-})$	[1, 2, 3]		0.15	$(V_S - 0.2) / \text{Gain}$	V
$V_{CM}$	Common-mode input range		[1, 2, 3]	-16		80	V
CMRR	Common-mode rejection ratio	$V_{IN+} = -15\text{ V to } 80\text{ V}$	[1]	80	120		dB
			[2, 3]	70	120		
$V_{OS}$	Offset voltage, RTI		[1]		$\pm 0.5$	$\pm 2.5$	mV
			[2, 3]			$\pm 3.5$	
$dV_{OS}/dT$					2.5		$\mu\text{V}/^\circ\text{C}$
PSR	$V_{OS}$ vs power-supply		[1, 2, 3]		5	250	$\mu\text{V}/\text{V}$
$I_B$	Input bias current, $V_{IN-}$ pin		[1]		$\pm 8$	$\pm 16$	$\mu\text{A}$
			[2, 3]			$\pm 19$	
	PRE OUT output impedance				96		k $\Omega$
	Buffer input bias current				-50		nA
	Buffer input bias current temperature coefficient				$\pm 0.03$		nA/ $^\circ\text{C}$
<b>OUTPUT (<math>V_{SENSE} \geq 20\text{ mV}</math>)<sup>(2)</sup></b>							
G	Gain				20		V/V
$G_{BUF}$	Output buffer gain				2		V/V
	Total gain error	$V_{SENSE} = 20\text{ mV to } 100\text{ mV}$	[4, 5, 6]		$\pm 0.2\%$	$\pm 1.5\%$	
	Total gain error vs temperature	$T_A = -55^\circ\text{C to } 125^\circ\text{C}$			50		ppm/ $^\circ\text{C}$
	Total output error <sup>(3)</sup>		[4]		$\pm 0.75\%$	$\pm 2\%$	
			[5, 6]			$\pm 3\%$	
	Nonlinearity error	$V_{SENSE} = 20\text{ mV to } 100\text{ mV}$			$\pm 0.002\%$		
$R_O$	Output impedance, pin 5				1.5		$\Omega$
	Maximum capacitive load	No sustained oscillation			10		nF
<b>VOLTAGE OUTPUT (<math>R_L = 10\text{ k}\Omega</math> to GND)</b>							
	Swing to V+ power-supply rail		[1, 2, 3]		$(V+) - 0.05$	$(V+) - 0.2$	V
	Swing to GND		[1, 2, 3]		$V_{GND} + 0.003$	$V_{GND} + 0.05$	V
<b>FREQUENCY RESPONSE</b>							
BW	Bandwidth	$C_{LOAD} = 5\text{ pF}$			130		kHz
	Phase margin	$C_{LOAD} < 10\text{ nF}$			40		$^\circ$
SR	Slew rate				1		V/ $\mu\text{s}$
$t_S$	Settling time (1%)	$V_{SENSE} = 10\text{ mV to } 100\text{ mV}_{PP}$ , $C_{LOAD} = 5\text{ pF}$			2		$\mu\text{s}$

(1) For subgroup definitions, please see [Quality Conformance Inspection](#) table.

(2) For output behavior when  $V_{SENSE} < 20\text{ mV}$ , see the [Accuracy Variations as a Result of  \$V\_{SENSE}\$  and Common-Mode Voltage](#) section.

(3) Total output error includes effects of gain error and  $V_{OS}$ .

## Electrical Characteristics (continued)

$V_S = 2.7\text{ V}$  and  $16\text{ V}$ ,  $V_{CM} = -15\text{ V}$ ,  $12\text{ V}$  and  $80\text{ V}$ ,  $V_{SENSE} = 100\text{ mV}$ , and PRE OUT connected to BUF IN, unless otherwise noted.  $T_A$  is as shown in SUBGROUP column.

PARAMETER	TEST CONDITIONS	SUBGROUP <sup>(1)</sup>	MIN	TYP	MAX	UNIT
<b>NOISE, RTI<sup>(4)</sup></b>						
$e_n$	Voltage noise density			40		nV/ $\sqrt{\text{Hz}}$
<b>POWER SUPPLY</b>						
$V_S$	Operating range	[1, 2, 3]	2.7		16	V
$I_Q$	Quiescent current	$V_{OUT} = 2\text{ V}$	[1]	700	900	$\mu\text{A}$
			[2, 3]	700	1200	
		$V_{SENSE} = 0\text{ mV}$	[1]	350	500	
			[2, 3]	350	650	

(4) RTI means *Referred-to-Input*.

## 6.6 Quality Conformance Inspection

MIL-STD-883, Method 5005 - Group A

SUBGROUP	DESCRIPTION	TEMP (°C)
1	Static tests at	25
2	Static tests at	125
3	Static tests at	-55
4	Dynamic tests at	25
5	Dynamic tests at	125
6	Dynamic tests at	-55
7	Functional tests at	25
8A	Functional tests at	125
8B	Functional tests at	-55
9	Switching tests at	25
10	Switching tests at	125
11	Switching tests at	-55
12	Setting time at	25
13	Setting time at	125
14	Setting time at	-55

### 6.7 Typical Characteristics

At  $T_A = 25^\circ\text{C}$ ,  $V_S = 12\text{ V}$ ,  $V_{\text{CM}} = 12\text{ V}$ , and  $V_{\text{SENSE}} = 100\text{ mV}$ , unless otherwise noted.

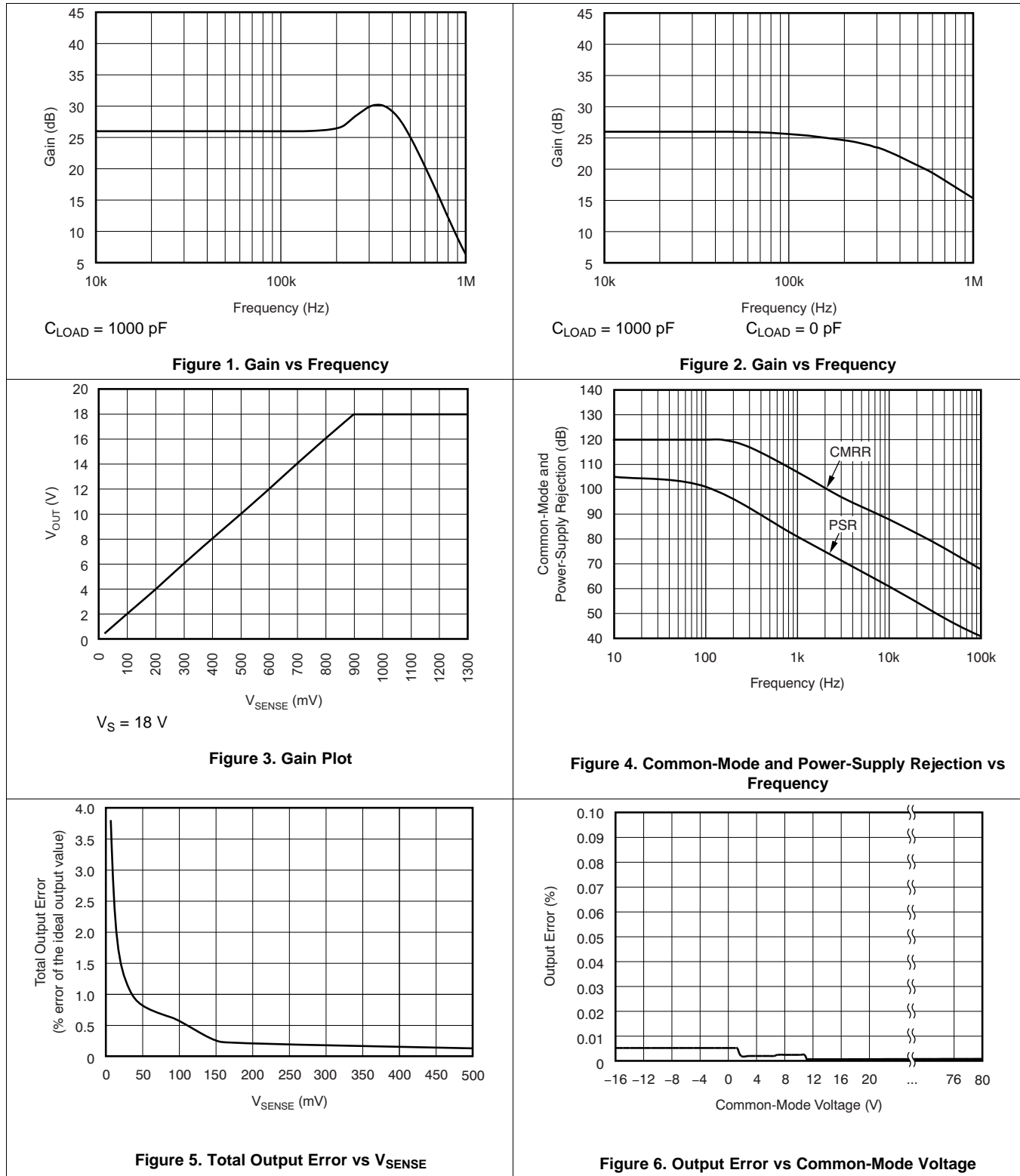

Typical Characteristics (continued)

At  $T_A = 25^\circ\text{C}$ ,  $V_S = 12\text{ V}$ ,  $V_{CM} = 12\text{ V}$ , and  $V_{SENSE} = 100\text{ mV}$ , unless otherwise noted.

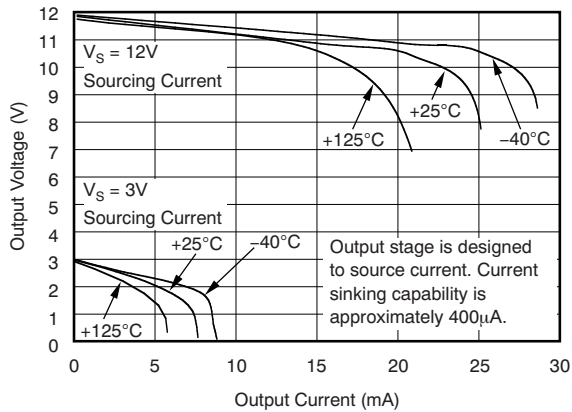

Figure 7. Positive Output Voltage Swing vs Output Current

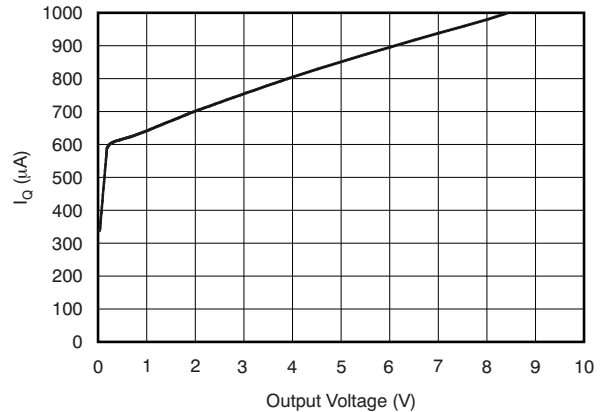

Figure 8. Quiescent Current vs Output Voltage

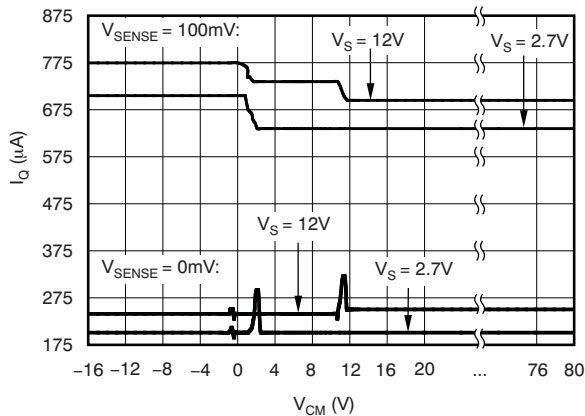

Figure 9. Quiescent Current vs Common-Mode Voltage

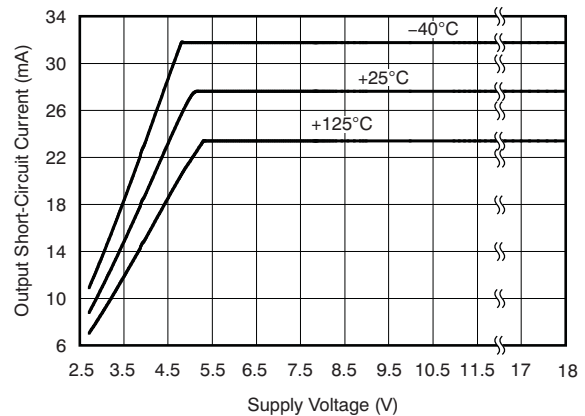

Figure 10. Output Short-Circuit Current vs Supply Voltage

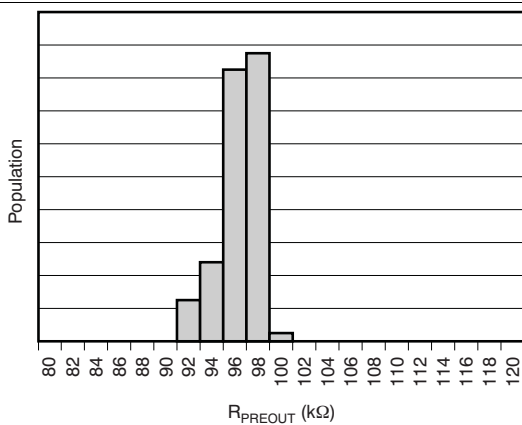

Figure 11. PRE OUT Output Resistance Production Distribution

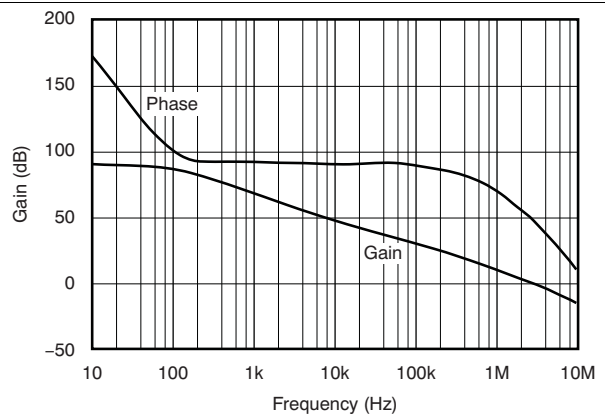
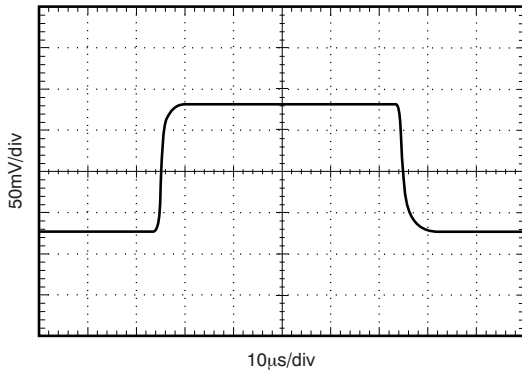

Figure 12. Buffer Gain vs Frequency



**Typical Characteristics (continued)**

At  $T_A = 25^\circ\text{C}$ ,  $V_S = 12\text{ V}$ ,  $V_{CM} = 12\text{ V}$ , and  $V_{SENSE} = 100\text{ mV}$ , unless otherwise noted.



**Figure 13. Small-Signal Step Response  
(10-mV to 20-mV Input)**

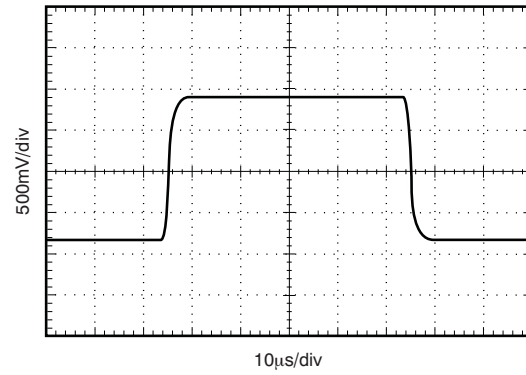

**Figure 14. Large-Signal Step Response  
(10-mV to 100-mV Input)**

## 7 Detailed Description

### 7.1 Overview

The INA901-SP current-shunt monitor with voltage output can sense drops across current shunts at common-mode voltages from  $-16\text{ V}$  to  $80\text{ V}$ , independent of the supply voltage. The INA901-SP pinouts readily enable filtering.

The INA901-SP is available with a  $20\text{-V/V}$  output voltage scale. The  $130\text{-kHz}$  bandwidth simplifies use in current-control loops.

The INA901-SP operates from a single  $2.7\text{-V}$  to  $18\text{-V}$  supply, drawing a maximum of  $900\text{ }\mu\text{A}$  of supply current. The devices are specified over the extended operating temperature range of  $-55^\circ\text{C}$  to  $125^\circ\text{C}$  and are offered in an 8-pin CFP package.

### 7.2 Functional Block Diagram

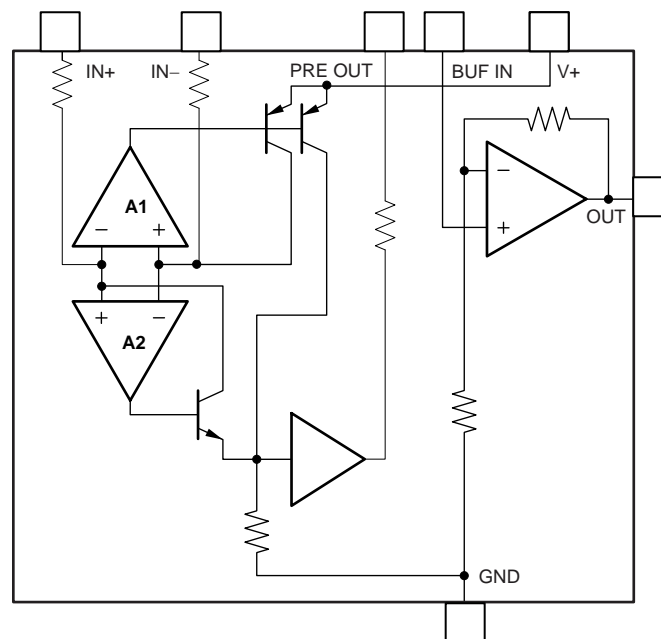

## 7.3 Feature Description

### 7.3.1 Basic Connection

Figure 15 shows the basic connection of the INA901-SP. Connect the input pins (IN+ and IN–) as closely as possible to the shunt resistor to minimize any resistance in series with the shunt resistance.

Power-supply bypass capacitors are required for stability. Applications with noisy or high-impedance power supplies may require additional decoupling capacitors to reject power-supply noise. Place minimum bypass capacitors of 0.01  $\mu\text{F}$  and 0.1  $\mu\text{F}$  in value close to the supply pins. Although not mandatory, an additional 10-mF electrolytic capacitor placed in parallel with the other bypass capacitors may be useful in applications with particularly noisy supplies.

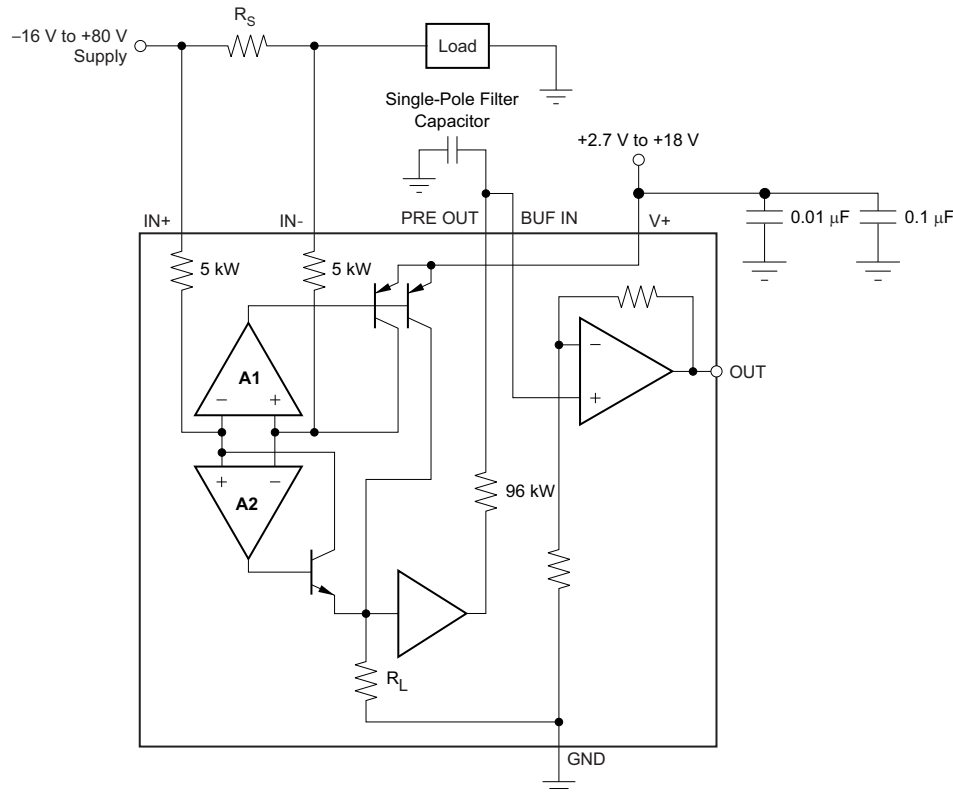

Figure 15. INA901-SP Basic Connections

### 7.3.2 Selecting $R_S$

The value chosen for the shunt resistor,  $R_S$ , depends on the application and is a compromise between small-signal accuracy and maximum permissible voltage loss in the measurement line. High values of  $R_S$  provide better accuracy at lower currents by minimizing the effects of offset, while low values of  $R_S$  minimize voltage loss in the supply line. For most applications, best performance is attained with an  $R_S$  value that provides a full-scale shunt voltage range of 50 mV to 100 mV. Maximum input voltage for accurate measurements is  $(V_S - 0.2) / \text{Gain}$ .

### 7.3.3 Transient Protection

The –16-V to 80-V common-mode range of INA901-SP is ideal for withstanding fault conditions ranging from 12-V battery reversal up to 80-V transients because no additional protective components are needed up to those levels. In the event that INA901-SP is exposed to transients on the inputs in excess of their ratings, external transient absorption with semiconductor transient absorbers (Zeners or Transzorbs) are necessary.

### Feature Description (continued)

Use of MOVs or VDRs is not recommended except when they are used in addition to a semiconductor transient absorber. Select the transient absorber such that it never allows the INA901-SP to be exposed to transients greater than 80 V (that is, allow for transient absorber tolerance, as well as additional voltage because of transient absorber dynamic impedance). Despite the use of internal Zener-type ESD protection, the INA901-SP is not suited to using external resistors in series with the inputs because the internal gain resistors can vary up to  $\pm 30\%$ , but are tightly matched (if gain accuracy is not important, then resistors can be added in series with the INA901-SP inputs with two equal resistors on each input).

## 7.4 Device Functional Modes

### 7.4.1 First- or Second-Order Filtering

The output of the INA901-SP is accurate within the output voltage swing range set by the power-supply pin, V+.

The INA901-SP readily enables the inclusion of filtering between the preamp output and buffer input. Single-pole filtering can be accomplished with a single capacitor because of the 96-kΩ output impedance at PRE OUT on pin 3, as shown in Figure 16a.

The INA901-SP readily lends to second-order Sallen-Key configurations, as shown in Figure 16b. When designing these configurations consider that the PRE OUT 96-kΩ output impedance exhibits an initial variation of ±30% with the addition of a –2200-ppm/°C temperature coefficient.

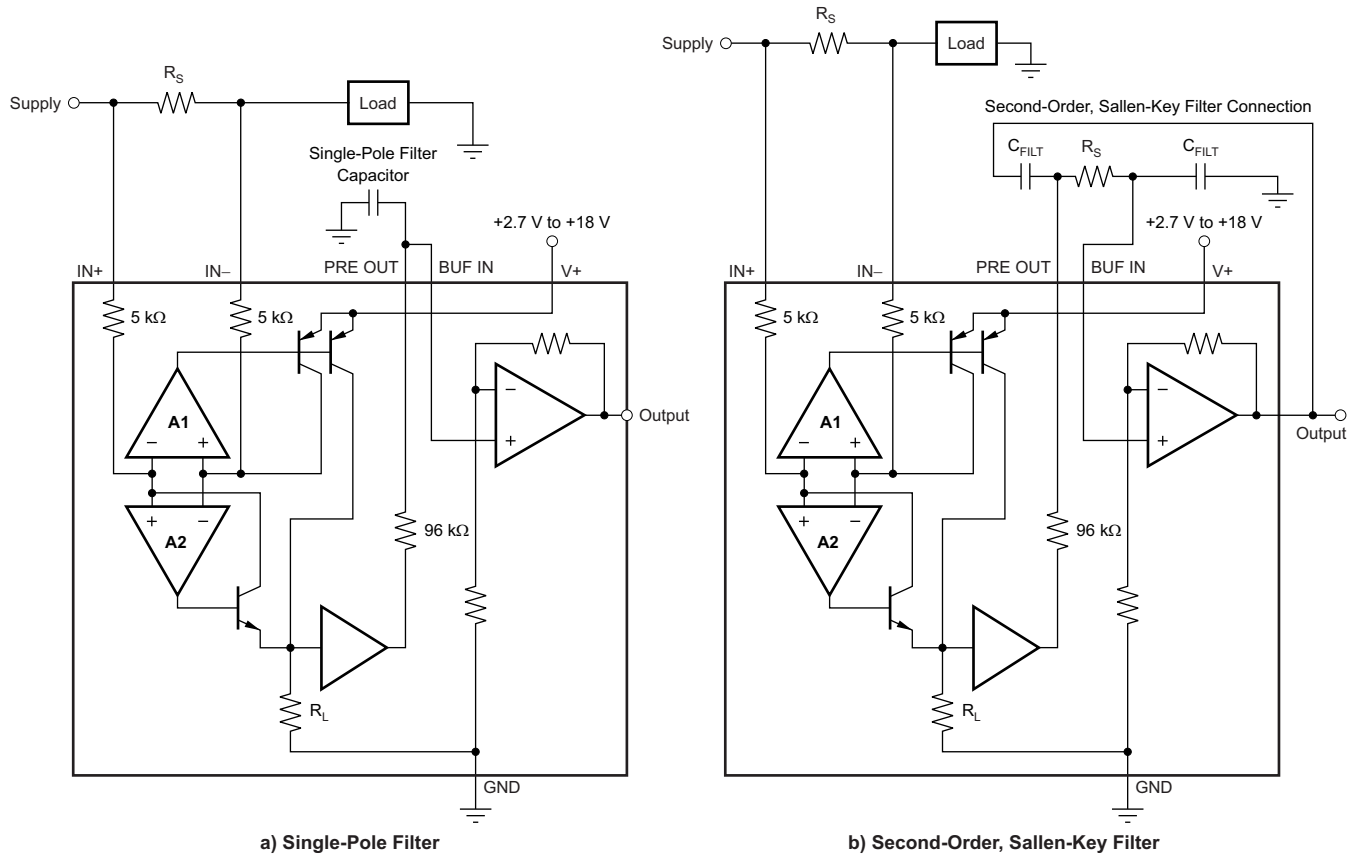

NOTE: Remember to use the appropriate buffer gain = 2 when designing Sallen-Key configurations.

**Figure 16. The INA901-SP Can Be Easily Connected for First- or Second-Order Filtering**

### 7.4.2 Accuracy Variations as a Result of $V_{SENSE}$ and Common-Mode Voltage

The accuracy of the INA901-SP current shunt monitors is a function of two main variables:  $V_{SENSE}$  ( $V_{IN+} - V_{IN-}$ ) and common-mode voltage ( $V_{CM}$ ) relative to the supply voltage,  $V_S$ .  $V_{CM}$  is expressed as  $(V_{IN+} + V_{IN-}) / 2$ ; however, in practice,  $V_{CM}$  is used as the voltage at  $V_{IN+}$  because the voltage drop across  $V_{SENSE}$  is usually small.

This section addresses the accuracy of these specific operating regions:

Normal Case 1:  $V_{SENSE} \geq 20$  mV,  $V_{CM} \geq V_S$

Normal Case 2:  $V_{SENSE} \geq 20$  mV,  $V_{CM} < V_S$

Low  $V_{SENSE}$  Case 1:

$V_{SENSE} < 20$  mV,  $-16$  V  $\leq V_{CM} < 0$

Low  $V_{SENSE}$  Case 2:

$V_{SENSE} < 20$  mV,  $0$  V  $\leq V_{CM} \leq V_S$

## Device Functional Modes (continued)

Low  $V_{SENSE}$  Case 3:

$$V_{SENSE} < 20 \text{ mV}, V_S < V_{CM} \leq 80 \text{ V}$$

### 7.4.2.1 Normal Case 1: $V_{SENSE} \geq 20 \text{ mV}$ , $V_{CM} \geq V_S$

This region of operation provides the highest accuracy. Here, the input offset voltage is characterized and measured using a two-step method. First, the gain is determined by [Equation 1](#).

$$G = \frac{V_{OUT1} - V_{OUT2}}{100\text{mV} - 20\text{mV}}$$

where

- $V_{OUT1}$  = Output voltage with  $V_{SENSE} = 100 \text{ mV}$  and
- $V_{OUT2}$  = Output voltage with  $V_{SENSE} = 20 \text{ mV}$ . (1)

Then the offset voltage is measured at  $V_{SENSE} = 100 \text{ mV}$  and referred to the input (RTI) of the current shunt monitor, as shown in [Equation 2](#).

$$V_{OS\text{RTI}} \text{ (Referred-To-Input)} = \left[ \frac{V_{OUT1}}{G} \right] - 100\text{mV} \quad (2)$$

In the [Typical Characteristics](#) section, the *Output Error vs Common-Mode Voltage* curve ([Figure 6](#)) shows the highest accuracy for the this region of operation. In this plot,  $V_S = 12 \text{ V}$ ; for  $V_{CM} \geq 12 \text{ V}$ , the output error is at its minimum. This case is also used to create the  $V_{SENSE} \geq 20\text{-mV}$  output specifications in the [Electrical Characteristics](#) table.

### 7.4.2.2 Normal Case 2: $V_{SENSE} \geq 20 \text{ mV}$ , $V_{CM} < V_S$

This region of operation has slightly less accuracy than [Normal Case 1](#) as a result of the common-mode operating area in which the device functions, as illustrated in the *Output Error vs Common-Mode Voltage* curve ([Figure 6](#)). As noted, for this graph  $V_S = 12 \text{ V}$ ; for  $V_{CM} < 12 \text{ V}$ , the output error increases when  $V_{CM}$  becomes less than  $12 \text{ V}$ , with a typical maximum error of 0.005% at the most negative  $V_{CM} = -16 \text{ V}$ .

### 7.4.2.3 Low $V_{SENSE}$ Case 1: $V_{SENSE} < 20 \text{ mV}$ , $-16 \text{ V} \leq V_{CM} < 0$ ; and Low $V_{SENSE}$ Case 3: $V_{SENSE} < 20 \text{ mV}$ , $V_S < V_{CM} \leq 80 \text{ V}$

Although the INA901-SP is not designed for accurate operation in either of these regions, some applications are exposed to these conditions. For example, when monitoring power supplies that are switched on and off while  $V_S$  is still applied to the INA901-SP, knowing what the behavior of the devices is in these regions is important.

**Device Functional Modes (continued)**

When  $V_{SENSE}$  approaches 0 mV, in these  $V_{CM}$  regions, the device output accuracy degrades. A larger-than-normal offset can appear at the current shunt monitor output with a typical maximum value of  $V_{OUT} = 60$  mV for  $V_{SENSE} = 0$  mV. When  $V_{SENSE}$  approaches 20 mV,  $V_{OUT}$  returns to the expected output value with accuracy as specified in the *Electrical Characteristics* table. Figure 17 shows this effect using the INA901-SP (gain = 20).

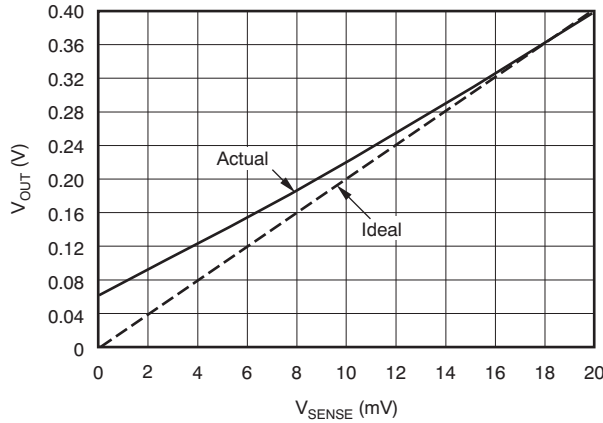
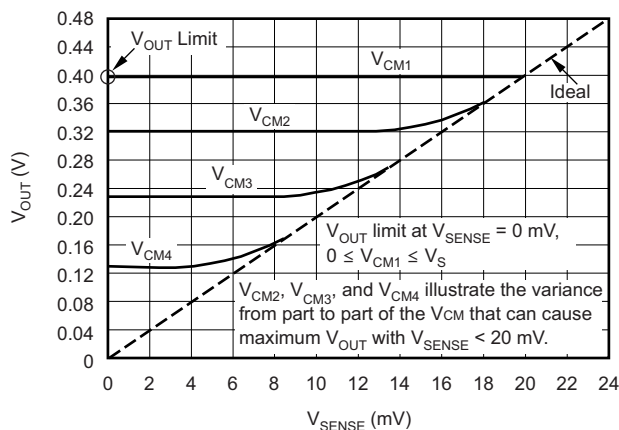

**Figure 17. Example For Low  $V_{SENSE}$  Cases 1 and 3 (INA901-SP Gain = 20)**

**7.4.2.4 Low  $V_{SENSE}$  Case 2:  $V_{SENSE} < 20$  mV,  $0$  V  $\leq V_{CM} \leq V_S$**

This region of operation is the least accurate for the INA901-SP. To achieve the wide input common-mode voltage range, these devices use two op amp front ends in parallel. One op amp front end operates in the positive input common-mode voltage range, and the other in the negative input region. For this case, neither of these two internal amplifiers dominates and overall loop gain is very low. Within this region,  $V_{OUT}$  approaches voltages close to linear operation levels for *Normal Case 2*.

This deviation from linear operation becomes greatest the closer  $V_{SENSE}$  approaches 0 V. Within this region, when  $V_{SENSE}$  approaches 20 mV, device operation is closer to that described by *Normal Case 2*. Figure 18 shows this behavior for the INA901-SP. The  $V_{OUT}$  maximum peak for this case is determined by maintaining a constant  $V_S$ , setting  $V_{SENSE} = 0$  mV, and sweeping  $V_{CM}$  from 0 V to  $V_S$ . The exact  $V_{CM}$  at which  $V_{OUT}$  peaks during this case varies from device to device. The maximum peak voltage for the INA901-SP is 0.4 V.



**Figure 18. Example for Low  $V_{SENSE}$  Case 2 (INA901-SP, Gain = 20)**

## 8 Application and Implementation

### NOTE

Information in the following applications sections is not part of the TI component specification, and TI does not warrant its accuracy or completeness. TI's customers are responsible for determining suitability of components for their purposes. Customers should validate and test their design implementation to confirm system functionality.

### 8.1 Application Information

The INA901-SP measures the voltage developed across a current-sensing resistor when current passes through it. There is also a filtering feature to remove unwanted transients and smooth the output voltage.

### 8.2 Typical Application

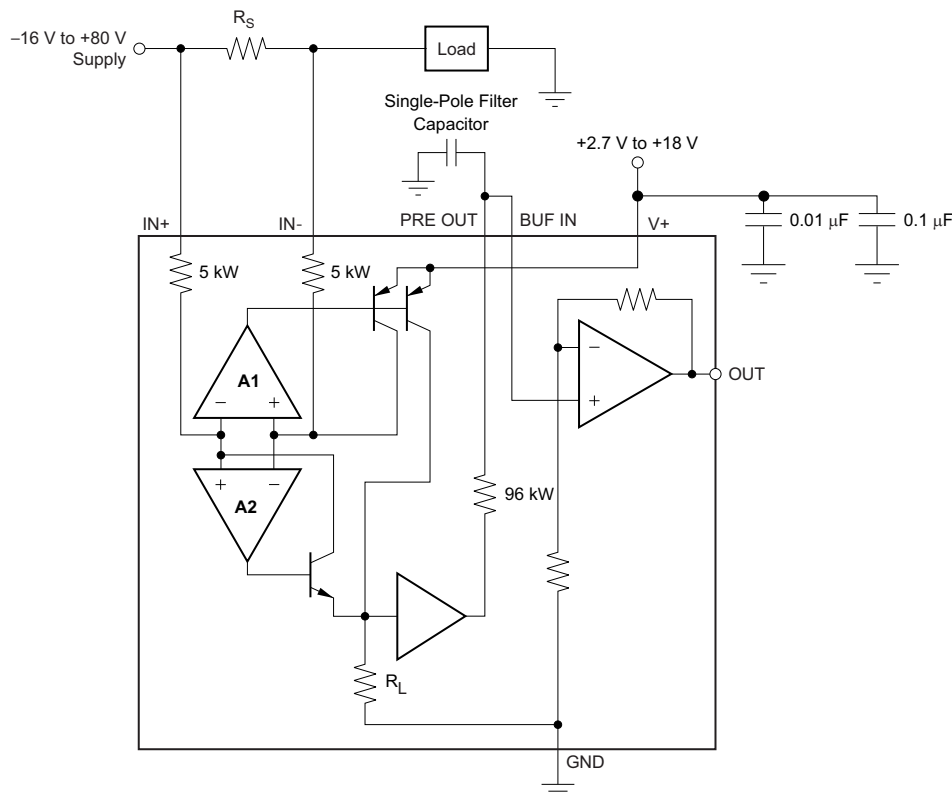

**Figure 19. Filtering Configuration**

#### 8.2.1 Design Requirements

In this application, the device is configured to measure a triangular periodic current at 10 kHz with filtering. The average current through the shunt is the information that is desired. This current can be either solenoid current or inductor current where current is being pulsed through.

Selecting the capacitor size is based on the lowest frequency component to be filtered out. The amount of signal that is filtered out is dependant on this cutoff frequency. From the cutoff frequency, the attenuation is 20 dB per decade.



## Typical Application (continued)

### 8.2.2 Detailed Design Procedure

Without this filtering capability, an input filter must be used. When series resistance is added to the input, large errors also come into play because the resistance must be large to create a low cutoff frequency. By using a 10-nF capacitor for the single-pole filter capacitor, the 10-kHz signal is averaged. The cutoff frequency made by the capacitor is set at 166-Hz frequency. This frequency is well below the periodic frequency and reduces the ripple on the output and the average current can easily be measured.

### 8.2.3 Application Curves

Figure 20 shows the output waveform without filtering. The output signal tracks the input signal with a large ripple. If this current is sampled by an ADC, many samples must be taken to average the current digitally. This process requires additional time for sampling or operating at a higher sampling rate, which may be undesirable for the application.

Figure 21 shows the output waveform with filtering. shows the output waveform with filtering. The average value of the current with a small ripple can now be easily sampled by the converter without the need for digital averaging.

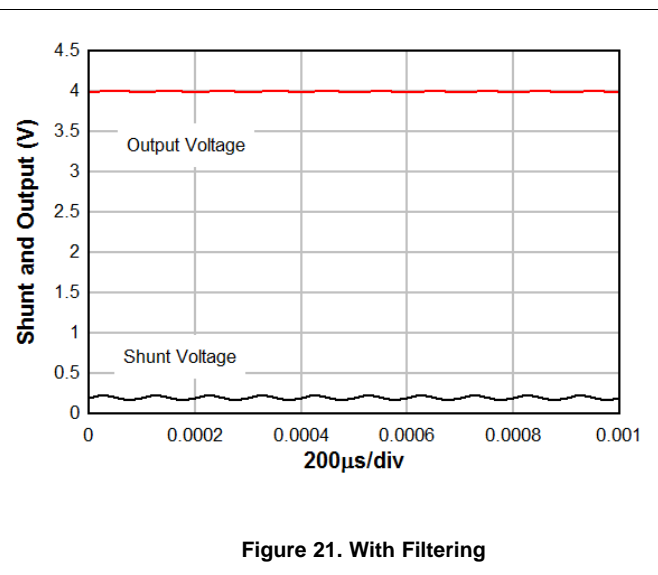
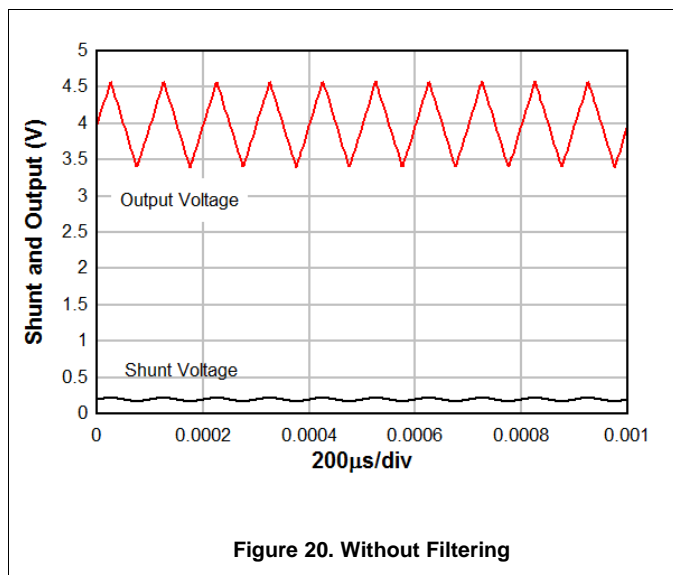

## 9 Power Supply Recommendations

The input circuitry of the INA901-SP can accurately measure beyond its power-supply voltage,  $V+$ . For example, the  $V+$  power supply can be 5 V, whereas the load power-supply voltage is up to 80 V. The output voltage range of the OUT terminal, however, is limited by the voltages on the power-supply pin.

## 10 Layout

### 10.1 Layout Guidelines

- Connect the input pins to the sensing resistor using a Kelvin or 4-wire connection. This connection technique ensures that only the current-sensing resistor impedance is detected between the input pins. Poor routing of the current-sensing resistor commonly results in additional resistance present between the input pins. Given the very low ohmic value of the current resistor, any additional high-current carrying impedance can cause significant measurement errors.
- Place the power-supply bypass capacitor as closely as possible to the supply and ground pins. The recommended value of this bypass capacitor is 0.1  $\mu\text{F}$ . Additional decoupling capacitance can be added to compensate for noisy or high-impedance power supplies.

#### 10.1.1 RFI and EMI

Attention to good layout practices is always recommended. Keep traces short and, when possible, use a printed circuit board (PCB) ground plane with surface-mount components placed as close to the device pins as possible. Small ceramic capacitors placed directly across amplifier inputs can reduce RFI and EMI sensitivity. PCB layout must locate the amplifier as far away as possible from RFI sources. Sources can include other components in the same system as the amplifier itself, such as inductors (particularly switched inductors handling a lot of current and at high frequencies). RFI can generally be identified as a variation in offset voltage or dc signal levels with changes in the interfering RF signal. If the amplifier cannot be located away from sources of radiation, shielding may be needed. Twisting wire input leads makes them more resistant to RF fields.

### 10.2 Layout Example

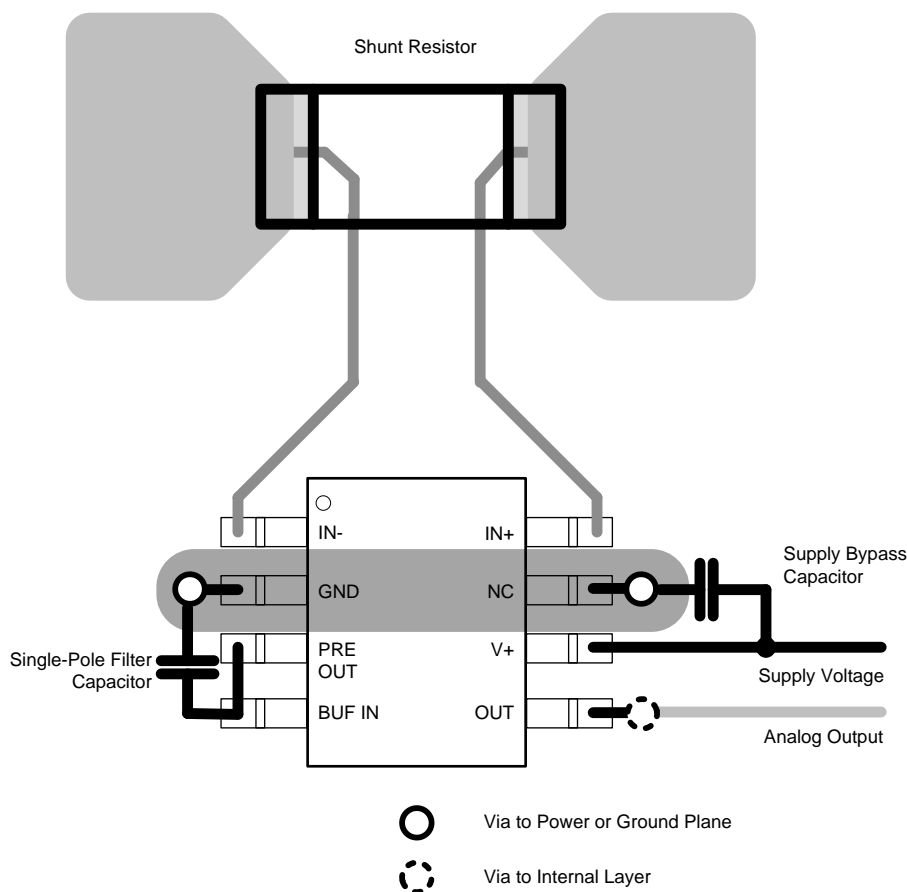

Figure 22. Example Layout

## 11 器件和文档支持

### 11.1 文档支持

#### 11.1.1 相关文档

请参阅 [ti.com.cn](http://ti.com.cn) 中的 INA901-SP 产品文件夹，获取[技术文档](#)和[工具与软件](#)的链接。

### 11.2 接收文档更新通知

要接收文档更新通知，请导航至 [TI.com.cn](http://TI.com.cn) 上的器件产品文件夹。单击右上角的[通知我](#)进行注册，即可每周接收产品信息更改摘要。有关更改的详细信息，请查看任何已修订文档中包含的修订历史记录。

### 11.3 社区资源

下列链接提供到 TI 社区资源的连接。链接的内容由各个分销商“按照原样”提供。这些内容并不构成 TI 技术规范，并且不一定反映 TI 的观点；请参阅 TI 的 [《使用条款》](#)。

**TI E2E™ 在线社区** [TI 的工程师对工程师 \(E2E\) 社区](#)。此社区的创建目的在于促进工程师之间的协作。在 [e2e.ti.com](http://e2e.ti.com) 中，您可以咨询问题、分享知识、拓展思路并与同行工程师一道帮助解决问题。

**设计支持** [TI 参考设计支持](#) 可帮助您快速查找有帮助的 E2E 论坛、设计支持工具以及技术支持的联系信息。

### 11.4 商标

E2E is a trademark of Texas Instruments.

All other trademarks are the property of their respective owners.

### 11.5 静电放电警告



ESD 可能会损坏该集成电路。德州仪器 (TI) 建议通过适当的预防措施处理所有集成电路。如果不遵守正确的处理措施和安装程序，可能会损坏集成电路。

ESD 的损坏小至导致微小的性能降级，大至整个器件故障。精密的集成电路可能更容易受到损坏，这是因为非常细微的参数更改都可能会导致器件与其发布的规格不相符。

### 11.6 术语表

[SLYZ022](#) — *TI* 术语表。

这份术语表列出并解释术语、缩写和定义。

## 12 机械、封装和可订购信息

以下页面包含机械、封装和可订购信息。这些信息是指定器件的最新可用数据。数据如有变更，恕不另行通知，且不会对此文档进行修订。如需获取此数据表的浏览器版本，请查阅左侧的导航栏。

**PACKAGING INFORMATION**

Orderable Device	Status (1)	Package Type	Package Drawing	Pins	Package Qty	Eco Plan (2)	Lead finish/ Ball material (6)	MSL Peak Temp (3)	Op Temp (°C)	Device Marking (4/5)	Samples
5962-1821001VXC	ACTIVE	CFP	HKX	8	1	RoHS-Exempt & Green	NIAU	N / A for Pkg Type	-55 to 125	1821001VXC INA901-SP	<a href="#">Samples</a>
5962L1821001VXC	ACTIVE	CFP	HKX	8	1	RoHS-Exempt & Green	NIAU	N / A for Pkg Type	-55 to 125	5962L1821001VXC INA901-SP	<a href="#">Samples</a>
INA901HKX/EM	ACTIVE	CFP	HKX	8	1	RoHS-Exempt & Green	NIAU	N / A for Pkg Type	25 to 25	INA901HKX/EM	<a href="#">Samples</a>

(1) The marketing status values are defined as follows:

**ACTIVE:** Product device recommended for new designs.

**LIFEBUY:** TI has announced that the device will be discontinued, and a lifetime-buy period is in effect.

**NRND:** Not recommended for new designs. Device is in production to support existing customers, but TI does not recommend using this part in a new design.

**PREVIEW:** Device has been announced but is not in production. Samples may or may not be available.

**OBSOLETE:** TI has discontinued the production of the device.

(2) **RoHS:** TI defines "RoHS" to mean semiconductor products that are compliant with the current EU RoHS requirements for all 10 RoHS substances, including the requirement that RoHS substance do not exceed 0.1% by weight in homogeneous materials. Where designed to be soldered at high temperatures, "RoHS" products are suitable for use in specified lead-free processes. TI may reference these types of products as "Pb-Free".

**RoHS Exempt:** TI defines "RoHS Exempt" to mean products that contain lead but are compliant with EU RoHS pursuant to a specific EU RoHS exemption.

**Green:** TI defines "Green" to mean the content of Chlorine (Cl) and Bromine (Br) based flame retardants meet JS709B low halogen requirements of <=1000ppm threshold. Antimony trioxide based flame retardants must also meet the <=1000ppm threshold requirement.

(3) MSL, Peak Temp. - The Moisture Sensitivity Level rating according to the JEDEC industry standard classifications, and peak solder temperature.

(4) There may be additional marking, which relates to the logo, the lot trace code information, or the environmental category on the device.

(5) Multiple Device Markings will be inside parentheses. Only one Device Marking contained in parentheses and separated by a "~" will appear on a device. If a line is indented then it is a continuation of the previous line and the two combined represent the entire Device Marking for that device.

(6) Lead finish/Ball material - Orderable Devices may have multiple material finish options. Finish options are separated by a vertical ruled line. Lead finish/Ball material values may wrap to two lines if the finish value exceeds the maximum column width.

**Important Information and Disclaimer:**The information provided on this page represents TI's knowledge and belief as of the date that it is provided. TI bases its knowledge and belief on information provided by third parties, and makes no representation or warranty as to the accuracy of such information. Efforts are underway to better integrate information from third parties. TI has taken and continues to take reasonable steps to provide representative and accurate information but may not have conducted destructive testing or chemical analysis on incoming materials and chemicals. TI and TI suppliers consider certain information to be proprietary, and thus CAS numbers and other limited information may not be available for release.

In no event shall TI's liability arising out of such information exceed the total purchase price of the TI part(s) at issue in this document sold by TI to Customer on an annual basis.

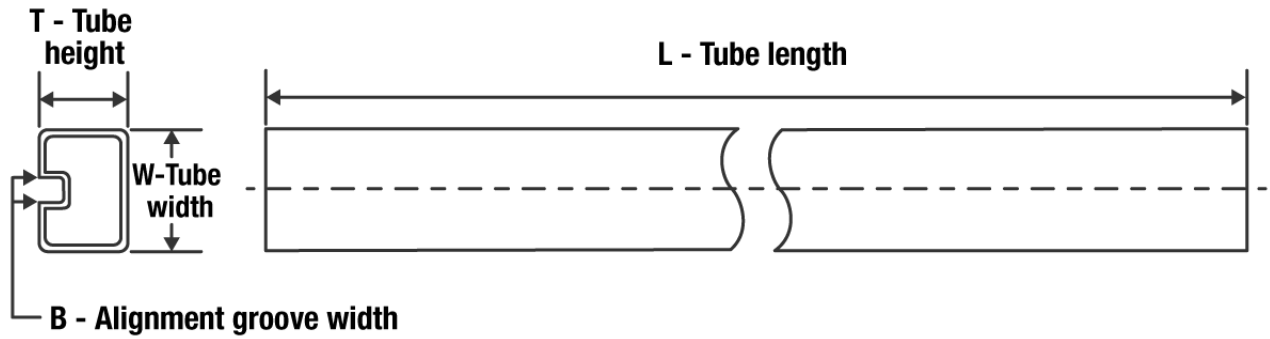
**TUBE**

\*All dimensions are nominal

Device	Package Name	Package Type	Pins	SPQ	L (mm)	W (mm)	T (μm)	B (mm)
5962-1821001VXC	HKX	CFP (HSL)	8	1	506.98	26.16	6220	NA
5962L1821001VXC	HKX	CFP (HSL)	8	1	506.98	26.16	6220	NA
INA901HKX/EM	HKX	CFP (HSL)	8	1	506.98	26.16	6220	NA



HKX0008A



**PACKAGE OUTLINE**  
**CFP - 2.785 mm max height**

CERAMIC FLATPACK

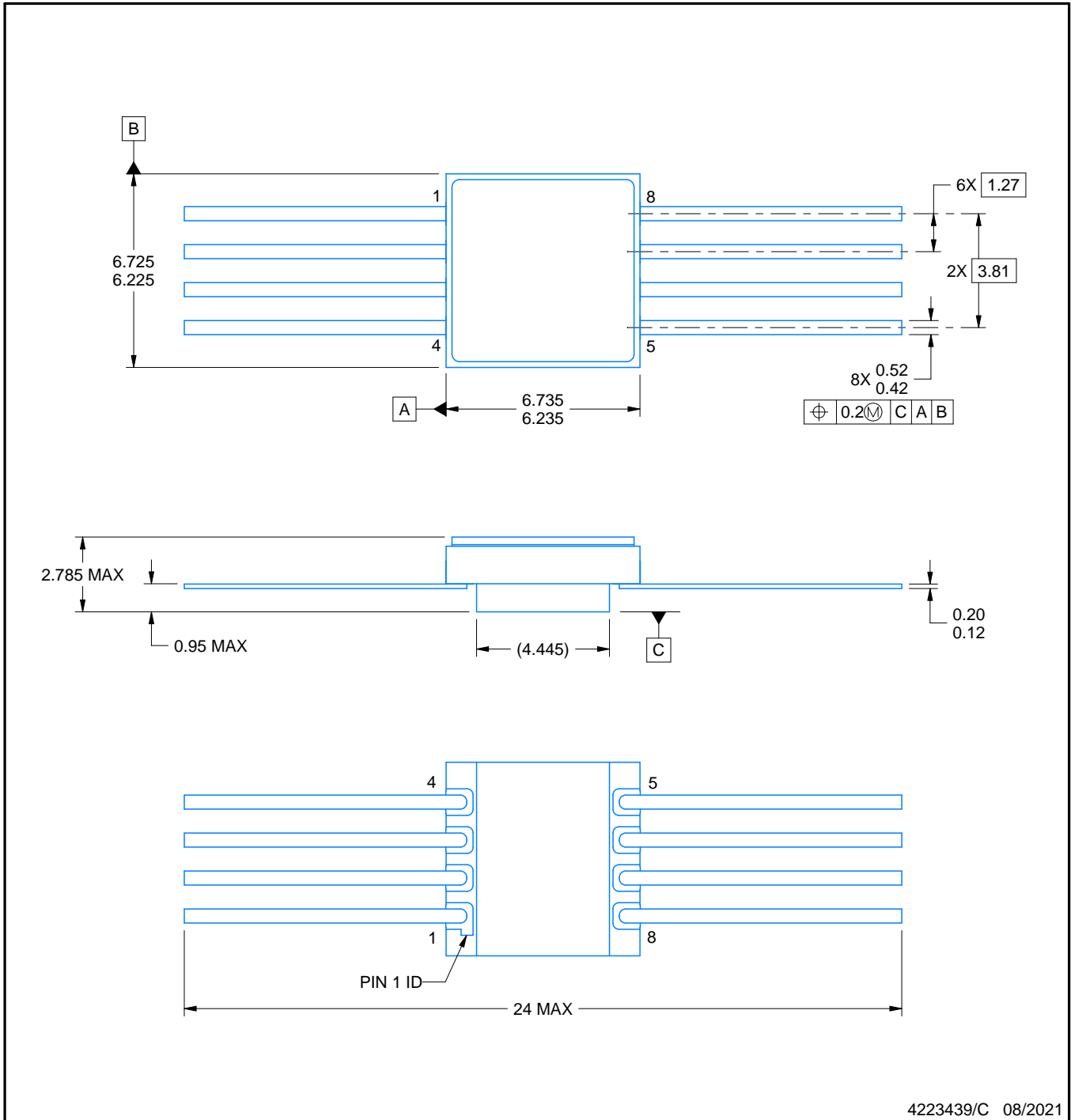

4223439/C 08/2021

NOTES:

1. All linear dimensions are in millimeters. Any dimensions in parenthesis are for reference only. Dimensioning and tolerancing per ASME Y14.5M.
2. This drawing is subject to change without notice.
3. This package is hermetically sealed with a metal lid.
4. The leads are gold plated.

## 重要声明和免责声明

TI“按原样”提供技术和可靠性数据（包括数据表）、设计资源（包括参考设计）、应用或其他设计建议、网络工具、安全信息和其他资源，不保证没有瑕疵且不做任何明示或暗示的担保，包括但不限于对适销性、某特定用途方面的适用性或不侵犯任何第三方知识产权的暗示担保。

这些资源可供使用 TI 产品进行设计的熟练开发人员使用。您将自行承担以下全部责任：(1) 针对您的应用选择合适的 TI 产品，(2) 设计、验证并测试您的应用，(3) 确保您的应用满足相应标准以及任何其他功能安全、信息安全、监管或其他要求。

这些资源如有变更，恕不另行通知。TI 授权您仅可将这些资源用于研发本资源所述的 TI 产品的应用。严禁对这些资源进行其他复制或展示。您无权使用任何其他 TI 知识产权或任何第三方知识产权。您应全额赔偿因在这些资源的使用中对 TI 及其代表造成的任何索赔、损害、成本、损失和债务，TI 对此概不负责。

TI 提供的产品受 [TI 的销售条款](#) 或 [ti.com](#) 上其他适用条款/TI 产品随附的其他适用条款的约束。TI 提供这些资源并不会扩展或以其他方式更改 TI 针对 TI 产品发布的适用的担保或担保免责声明。

TI 反对并拒绝您可能提出的任何其他或不同的条款。

邮寄地址：Texas Instruments, Post Office Box 655303, Dallas, Texas 75265

Copyright © 2022，德州仪器 (TI) 公司