

# 具有通用输入和输出的 CDCUN1208LP 400MHz 低功耗 2:8 扇出缓冲器

## 1 特性

- 支持 PCIe 1/2/3 代
- 配置选项（通过引脚或 SPI/I<sup>2</sup>C）：
  - 输入类型（高速电流驱动能力 (HCSL)，低压差分信号 (LVDS)，低压 COMS (LVCOMS)）
  - 输出类型 (HCSL, LVDS, LVCOMS)
  - 信号边沿速率（慢、中、快）
  - 时钟输入分配值 (/1, /2, /4, /8) - 只适用于 IN2
- 低功耗与电源管理 特性，包括 1.8V 运行和输出使能控制
- 具有集成稳压器，可改进 PSNR
- 卓越的附加抖动性能
  - LVDS 在 100MHz 时具有 200 fs RMS（10kHz 至 20MHz）
  - HCSL 在 100MHz 时具有 160 fs RMS（10kHz 至 20MHz）
- 最大工作频率：
  - 差分模式：高达 400MHz
  - LVCOMS 模式：高达 250MHz
- ESD 保护超过 2kV HBM、500V CDM
- 工业温度范围（-40°C 至 85°C）
- 宽电源范围（1.8V、2.5V 或者 3.3V）

## 2 应用

- 通信和计算系统
- 工厂自动化和控制
- 医疗成像
- 专业音频、视频和标牌
- 电机驱动器

## 3 说明

CDCUN1208LP 是一款 2:8 扇出缓冲器，具有宽工作电源电压范围、两个通用差分/单端输入以及具有边沿速率控制的通用输出（HCSL、LVDS 或 LVCMOS）。时钟缓冲器支持 PCIe 1/2/3 代。其中一个器件输入包括可提供 /1、/2、/4 或 /8 分频值的分频器。CDCUN1208LP 采用 32 引脚 QFN 封装，从而减小了解决方案的尺寸。此器件非常灵活并易于使用。某些特定引脚的状态决定了器件在加电时的配置。或者，CDCUN1208LP 提供一个 SPI/I<sup>2</sup>C 端口，在此端口上有一个主机处理器来控制器件的设置。

CDCUN1208LP 提供出色的附加抖动性能且功耗很低。输出部分包括四个专用电源引脚，这些引脚能够启用来自不同电源域的输出端口。这一功能使得时钟器件能够在不同的 LVCOMS 电平上切换，而无需外部逻辑电平转换电路。

### 器件信息<sup>(1)</sup>

器件型号	封装	封装尺寸（标称值）
CDCUN1208LP	VQFN (32)	5.00mm x 5.00mm

(1) 如需了解所有可用封装，请参阅产品说明书末尾的可订购产品附录。

### 引脚配置概述

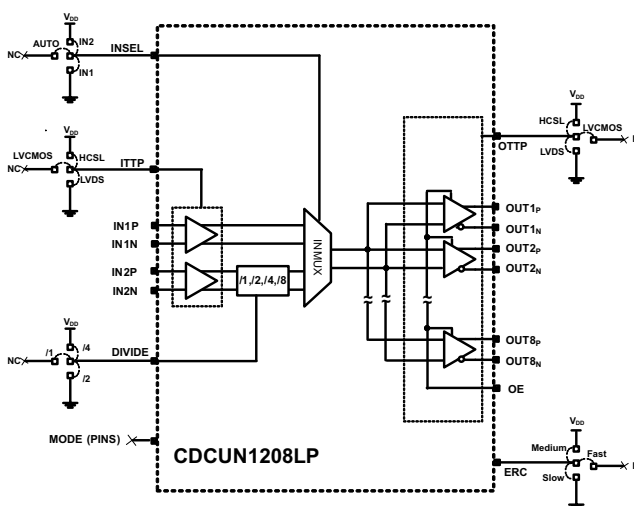

Copyright © 2017, Texas Instruments Incorporated



## 目录

<b>1</b>	<b>特性</b> .....	<b>1</b>	<b>8</b>	<b>Detailed Description</b> .....	<b>22</b>
<b>2</b>	<b>应用</b> .....	<b>1</b>	8.1	Overview .....	22
<b>3</b>	<b>说明</b> .....	<b>1</b>	8.2	Functional Block Diagrams .....	22
<b>4</b>	<b>修订历史记录</b> .....	<b>2</b>	8.3	Feature Description .....	23
<b>5</b>	<b>Pin Configuration and Functions</b> .....	<b>4</b>	8.4	Device Functional Modes .....	28
<b>6</b>	<b>Specifications</b> .....	<b>6</b>	8.5	Programming .....	30
6.1	Absolute Maximum Ratings .....	6	8.6	Register Maps .....	37
6.2	ESD Ratings .....	6	<b>9</b>	<b>Application and Implementation</b> .....	<b>39</b>
6.3	Recommended Operating Conditions .....	6	9.1	Application Information .....	39
6.4	Thermal Information .....	7	9.2	Typical Application .....	39
6.5	Digital Input Electrical Characteristics – OE (SCL), INSEL, ITTP, OTTP, Divide (SDA/MOSI), ERC(ADDR/CS), Mode .....	7	9.3	Systems Examples .....	41
6.6	Universal Input (IN1, IN2) Characteristics .....	8	<b>10</b>	<b>Power Supply Recommendations</b> .....	<b>42</b>
6.7	Clock Output Buffer Characteristics (Output Mode = LVDS) .....	9	10.1	CDCUN1208LP Power Consumption .....	42
6.8	Clock Output Buffer Characteristics (Output Mode = HCSL) .....	10	10.2	Device Power Supply Connections and Sequencing .....	42
6.9	Clock Output Buffer Electrical Characteristics (Output Mode = LVCMOS) .....	11	10.3	Device Inputs (IN1, IN2) .....	43
6.10	Clock Output Buffer Electrical Characteristics (Output Mode = LVCMOS) (Continued) .....	12	<b>11</b>	<b>Layout</b> .....	<b>44</b>
6.11	Clock Output Buffer Electrical Characteristics (Output Mode = LVCMOS) (Continued) .....	13	11.1	Layout Guidelines .....	44
6.12	Typical Characteristics .....	16	11.2	Layout Example .....	44
<b>7</b>	<b>Parameter Measurement Information</b> .....	<b>18</b>	<b>12</b>	<b>器件和文档支持</b> .....	<b>45</b>
7.1	Test Configurations .....	18	12.1	接收文档更新通知 .....	45
			12.2	社区资源 .....	45
			12.3	商标 .....	45
			12.4	静电放电警告 .....	45
			12.5	术语表 .....	45
			<b>13</b>	<b>机械、封装和可订购信息</b> .....	<b>45</b>

## 4 修订历史记录

注：之前版本的页码可能与当前版本有所不同。

Changes from Revision C (March 2017) to Revision D	Page
• 已更改 应用 列表 .....	1
• Added type descriptions to the <i>Pin Functions</i> table .....	4
• Changed input voltage maximum from: $V_{DDx} + 0.5$ to: $V_{DD} + 0.5$ in the <i>Absolute Maximum Ratings</i> table .....	6
• Added the junction temperature range to the <i>Absolute Maximum Ratings</i> table .....	6
• Changed the output current unit from mA °C to mA and moved the °C unit to the storage temperature parameter in the <i>Absolute Maximum Ratings</i> table .....	6
• Added note on $V_{DD}$ and $V_{DDOx}$ supply voltages .....	6
• Added text "Pull ADDR to GND for I2C communication" to the <i>CDCUN1208LP Host Configuration Pins</i> table .....	29
• Changed <i>SPI Message Format</i> graphic to correct SCS timing. ....	30
• Changed <i>CDCUN1208LP Device Addressing - SPI Mode</i> graphic to correct SCS timing. ....	30
• Changed <i>SPI Timing Diagram</i> graphic to correct SDI .....	31
• Changed $t_3$ in <i>SPI Timing Specifications</i> table to "SDI to SCL hold time" .....	32
• Changed $t_8$ in <i>SPI Timing Specifications</i> table to "SCL falling edge to SCS release time" .....	32
• Changed I <sup>2</sup> C address to 7b'0101000 in <i>CDCUN1208LP I<sup>2</sup>C Message - Addressing</i> graphic .....	34
• Changed description to reflect that the I <sup>2</sup> C address is 7b'0101000 in <i>CDCUN1208LP Device Addressing (I<sup>2</sup>C Address)</i> section .....	34
• Added content to the <i>Application Information</i> section .....	39

**Changes from Revision B (July 2013) to Revision C**
**Page**

• 已更改 添加了器件信息表、ESD 额定值表、应用和实施；电源建议；布局；器件和文档支持；机械、封装和可订购信息。 .....	1
• Added $\Delta V/\Delta T^2$ to the <i>Recommended Operating Conditions</i> table. ....	6
• Added text "note that CDCUN1208LP supports only single-device" to the first paragraph of <i>SPI Communication</i> . ....	30
• Added text "At no time should the clock be toggled while SCS is high. CDCUN1208LP should always be used in single-slave SPI configuration." to <i>Writing to the CDCUN1208LP</i> . ....	31
• Added text "At no time should the clock be toggled while SCS is high. CDCUN1208LP should always be used in single-slave SPI configuration." to <i>Reading From the CDCUN1208LP</i> . ....	31

**Changes from Revision A (January 2013) to Revision B**
**Page**

• Added slew rate note to Recommended Operating Conditions. ....	6
• Changed $V_{IOPEN1.8}$ from 0.9 V to 0.75 V in <i>Digital Input Electrical Characteristics – OE (SCL), INSEL, ITTP, OTTP, DIVIDE (SDA/MOSI), ERC(ADDR/CS), Mode</i> . ....	7
• Changed Fast to Medium and Medium to Fast in <i>Figure 28</i> . ....	24

**Changes from Original (May 2012) to Revision A**
**Page**

• 添加了特性：100MHz 下实现 160fs RMS (10kHz-20MHz)、HCSL。 .....	1
• 添加了特性：支持 PCIE 1/2/3 代。 .....	1
• 向说明部分添加了“此时钟缓冲器支持 PCIE 1/2/3 代”。 .....	1
• Added text to the Clock Output Buffer Characteristics table: "Supporting PCIe gen1, gen2, gen3." .....	10
• Changed <b>Table 4</b> From: DISABLED To: DISABLED in Tri_State .....	25
• Changed <b>Table 11</b> From: Disabled To: Disabled in Tri_State for OUTx_PD. ....	37
• Added text and <b>Figure 41</b> to the <i>PCI Express Applications</i> section. ....	39

## 5 Pin Configuration and Functions

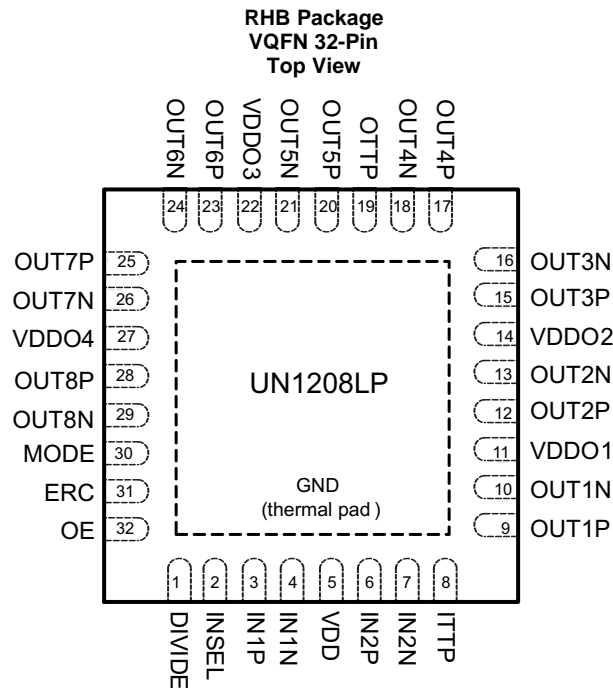

**Pin Functions<sup>(1)</sup>**

PIN		TYPE	DESCRIPTION
NAME	NO.		
GND	Thermal Pad	Power	Power supply ground and thermal relief
DIVIDE	1	Input	Input divider pin control (HIGH = /4, LOW = /2, OPEN = /1)
INSEL	2	Input	Input multiplexer control
IN1P	3	Input	Universal input 1 – positive terminal
IN1N	4	Input	Universal input 1 – negative terminal, ground if using IN1 in single-ended mode
VDD	5	Power	Device power supply; provides power to the input section and clock distribution section. Use a power supply voltage that corresponds to the switching levels of clock inputs (such as 1.8 V, 2.5 V, or 3.3 V).
IN2P	6	Input	Universal input 2 – positive terminal
IN2N	7	Input	Universal input 2 – negative terminal, ground if using IN2 in single-ended mode
ITTP	8	Input	Input type select (HIGH = HCSL, LOW = LVDS, OPEN = LVCMOS)
OUT1P	9	Output	Output 1 – positive terminal
OUT1N	10	Output	Output 1 – negative terminal
VDDO1	11	Power	Output power supply – OUT1, OUT2
OUT2P	12	Output	Output 2 – positive terminal
OUT2N	13	Output	Output 2 – negative terminal
VDDO2	14	Power	Output power supply – OUT3, OUT4; output bank OUT1 – OUT4 regulator power supply (apply power if any of OUT1 – OUT4 are needed)
OUT3P	15	Output	Output 3 – positive terminal
OUT3N	16	Output	Output 3 – negative terminal
OUT4P	17	Output	Output 4 – positive terminal
OUT4N	18	Output	Output 4 – negative terminal

(1) This pin list applies to operation of the device in pin mode. In host mode, certain pins take on an alternate function, as outlined in [Table 8](#).

**Pin Functions<sup>(1)</sup> (continued)**

PIN		TYPE	DESCRIPTION
NAME	NO.		
OTTP	19	Output	Output type select (HIGH = HCSL, LOW = LVDS, OPEN = LVCMOS)
OUT5P	20	Output	Output 5 – positive terminal
OUT5N	21	Output	Output 5 – negative terminal
VDDO3	22	Power	Output power supply - OUT5, OUT6
OUT6P	23	Output	Output 6 – positive terminal
OUT6N	24	Output	Output 6 – negative terminal
OUT7P	25	Output	Output 7 – positive terminal
OUT7N	26	Output	Output 7 – negative terminal
VDDO4	27	Power	Output power supply – OUT7, OUT8 output bank OUT5 – OUT8 regulator power supply (apply power if any of OUT5 – OUT8 are needed)
OUT8P	28	Output	Output 8 – positive terminal
OUT8N	29	Output	Output 8 – negative terminal
MODE	30	Input	Device control mode select OPEN = Device configured through pins (pin mode) HIGH = Device configured through I <sup>2</sup> C LOW = Device configured through SPI Note: For information on control through the serial interface (I <sup>2</sup> C/ SPI), see <a href="#">Device Control Using the Host Interface</a> section.
ERC	31	Input	Output edge rate control HIGH = Medium, LOW = Slow, OPEN = Fast
OE	32	Input	Device output enable HIGH = Enable, LOW = Disable

## 6 Specifications

### 6.1 Absolute Maximum Ratings

over operating free-air temperature range (unless otherwise noted) <sup>(1)</sup>

		MIN	MAX	UNIT
V <sub>DDxx</sub>	Supply voltage <sup>(2)</sup>	-0.5	4.6	V
V <sub>IN</sub>	Input voltage <sup>(3)</sup>	-0.5	V <sub>DD</sub> + 0.5	V
V <sub>OUT</sub>	Output voltage <sup>(3)</sup>	-0.5	V <sub>DDOx</sub> + 0.5	V
I <sub>IN</sub>	Input current	20		mA
I <sub>OUT</sub>	Output current	50		mA
T <sub>J</sub>	Junction temperature		125	°C
T <sub>stg</sub>	Storage temperature	-65	150	°C

- (1) Stresses beyond those listed under *Absolute Maximum Ratings* may cause permanent damage to the device. These are stress ratings only and functional operation of the device at these or any other conditions beyond those indicated under *Recommended Operating Conditions* is not implied. Exposure to absolute-maximum-rated conditions for extended periods may affect device reliability.
- (2) All supply voltages must be supplied simultaneously
- (3) The input and output negative voltage ratings may be exceeded if the input and output clamp-current ratings are observed.

### 6.2 ESD Ratings

		VALUE	UNIT
V <sub>(ESD)</sub>	Electrostatic discharge	Human body model (HBM), per ANSI/ESDA/JEDEC JS-001 <sup>(1)</sup>	±2000
		Charged device model (CDM), per JEDEC specification JESD22-C101 <sup>(2)</sup>	±500

- (1) JEDEC document JEP155 states that 500-V HBM allows safe manufacturing with a standard ESD control process.
- (2) JEDEC document JEP157 states that 250-V CDM allows safe manufacturing with a standard ESD control process.

### 6.3 Recommended Operating Conditions

T<sub>A</sub> = -40°C TO 85°C

		MIN	NOM	MAX	UNIT	
<b>POWER SUPPLIES <sup>(1)(2)(3)</sup></b>						
V <sub>DD</sub>	DC power supply - core	1.8-V mode	1.7	1.8	1.9	V
V <sub>DDOx</sub>	DC power supply - output	1.8-V mode	1.7	1.8	1.9	V
V <sub>DD</sub>	DC power supply - core	2.5-V mode	2.375	2.5	2.625	V
V <sub>DDOx</sub>	DC power supply - output	2.5-V mode	2.375	2.5	2.625	V
V <sub>DD</sub>	DC power supply - core	3.3-V mode	2.97	3.3	3.63	V
V <sub>DDOx</sub>	DC power supply - output	3.3-V mode	2.97	3.3	3.63	V
ΔV/ΔT <sup>2</sup>	Core power supply slew rate	0.4-V to 1.8-V × 0.8 (in all voltage modes)			6500	V/s
<b>TEMPERATURE</b>						
T <sub>A</sub>	Free- air temperature	-40		85		°C

- (1) For proper device operation, the core power supply voltage (pin 5) must be applied either before the application of any output power supply, or simultaneously with the application of the output power supplies. The application of an output power supply prior to the application of the core power supply could result in improper device behavior.
- (2) A minimum V<sub>DD</sub> slew rate of 6500 V/s should be obtained to ensure proper device functionality in pin mode. If the ambient temperature of the device is > 0°C, the slew rate can be as slow as 5000 V/s. In host mode (I<sup>2</sup>C/SPI), the V<sub>DD</sub> slew rate is not limited, if the Reset bit gets toggled after V<sub>DD</sub> ramp.
- (3) V<sub>DD</sub> and V<sub>DDOx</sub> can be operated from different supply voltages. Refer to [Configuration of Output Type \(OTTP\)](#) for more details.

## 6.4 Thermal Information

THERMAL METRIC <sup>(1)</sup>		CDCUN1208LP	UNIT
		RHB Package	
		32 PINS	
R <sub>θJA</sub>	Junction-to-ambient thermal resistance	32.5	°C/W
R <sub>θJC(top)</sub>	Junction-to-case (top) thermal resistance	24.2	°C/W
R <sub>θJB</sub>	Junction-to-board thermal resistance	6.6	°C/W
ψ <sub>JT</sub>	Junction-to-top characterization parameter	0.3	°C/W
ψ <sub>JB</sub>	Junction-to-board characterization parameter	6.6	°C/W
R <sub>θJC(bot)</sub>	Junction-to-case (bottom) thermal resistance	1.6	°C/W

(1) For more information about traditional and new thermal metrics, see the [IC Package Thermal Metrics](#) application report.

## 6.5 Digital Input Electrical Characteristics – OE (SCL), INSEL, ITTP, OTTP, Divide (SDA/MOSI), ERC(ADDR/CS), Mode

T<sub>A</sub> = –40°C to 85°C

PARAMETER		TEST CONDITIONS	MIN	TYP	MAX	UNIT
<b>LVC MOS INPUT</b>						
V <sub>IL1.8</sub>	Low-level LVC MOS input voltage	V <sub>DD</sub> = 1.8 V			0.7	V
V <sub>IH1.8</sub>	High-level LVC MOS input voltage	V <sub>DD</sub> = 1.8 V	1.35			V
V <sub>IOPEN1.8</sub>	OPEN-level LVC MOS input voltage	V <sub>DD</sub> = 1.8 V	0.75		1.2	V
V <sub>IL2.5</sub>	Low-level LVC MOS input voltage	V <sub>DD</sub> = 2.5 V			0.7	V
V <sub>IH2.5</sub>	High-level LVC MOS input voltage	V <sub>DD</sub> = 2.5 V	1.71			V
V <sub>IOPEN2.5</sub>	OPEN-level LVC MOS input voltage	V <sub>DD</sub> = 2.5 V	1		1.6	V
V <sub>IL3.3</sub>	Low-level LVC MOS input voltage	V <sub>DD</sub> = 3.3 V			1	V
V <sub>IH3.3</sub>	High-level LVC MOS input voltage	V <sub>DD</sub> = 3.3 V	2.3			V
V <sub>IOPEN3.3</sub>	OPEN-level LVC MOS input voltage	V <sub>DD</sub> = 3.3 V	1.3		1.9	V
I <sub>IL</sub>	Low-level LVC MOS input current	V <sub>DD</sub> = V <sub>DDmax</sub> , V <sub>ILCMOS</sub> = 0 V			–120	μA
I <sub>IH</sub>	High-level LVC MOS input current	V <sub>DD</sub> = V <sub>DDmax</sub> , V <sub>IHCMOS</sub> = 1.9 V			65	μA
C <sub>I</sub>	LVC MOS input capacitance			6		pF
V <sub>IK</sub>	Digital input clamp voltage	V <sub>DD</sub> = 1.7V, I <sub>I</sub> = –18 mA			–1.2	V

## 6.6 Universal Input (IN1, IN2) Characteristics

 $V_{DD} = 1.8\text{ V}, 2.5\text{ V}, 3.3\text{ V}, T_A = -40^\circ\text{C to } 85^\circ\text{C}$ 

PARAMETER		TEST CONDITIONS	MIN	TYP	MAX	UNIT
<b>SINGLE-ENDED MODE</b>						
$f_{IN1,2}$	Input frequency	Single ended <sup>(1)</sup>	0.008		250	MHz
$V_{IH}$	Input voltage - high	250 MHz	$0.7 \times V_{DD}$		$V_{DD}$	V
$V_{IL}$	Input voltage - low	250 MHz			$0.2 \times V_{DD}$	V
<b>DIFFERENTIAL MODE</b>						
$f_{INDIFF}$	Input frequency		0.008		400	MHz
$ V_{IN-DIFF} $	Input swing	$V_{DD} = 2.5\text{ V}, 3.3\text{ V}$	0.15		1.6	V
		$V_{DD} = 1.8\text{ V}$	0.15		1	V
$V_{CM}$	Input common mode voltage	ITTP = LVDS, $V_{DD} = 3.3\text{ V}$	0.8		2.5	V
		ITTP = LVDS, $V_{DD} = 2.5\text{ V}, 1.8\text{ V}$	0.8		$V_{DD} - 0.3$	
		ITTP = HCSL	-0.15		0.75	
<b>GENERAL CHARACTERISTICS</b>						
$I_{IH}$	Input current - high	$V_{DD} = 3.63\text{ V}, V_{IH} = 3.63\text{ V}$			30	$\mu\text{A}$
$I_{IL}$	Input current - low	$V_{DD} = 3.63\text{ V}, V_{IL} = 0\text{ V}$			-30	$\mu\text{A}$
$\Delta V/\Delta T$	Input edge rate	20%–80%	0.75			V/ns
$DC_{IN}$	Input duty cycle		40%		60%	
$C_{IN}$	Input capacitance			3.5		pF

- (1) When using an input in single-ended mode, ground the negative terminal (IN1N and/or IN2N) and drive the positive terminal (IN1P and/or IN2P).



## 6.7 Clock Output Buffer Characteristics (Output Mode = LVDS)

Unless otherwise noted,  $V_{DDOX} = 1.8\text{ V}, 2.5\text{ V}, 3.3\text{ V}$ ;  $T_A = -40^\circ\text{C}$  to  $85^\circ\text{C}$ . See [Figure 15](#), [Figure 16](#), and [Figure 17](#).

PARAMETER		TEST CONDITIONS	MIN	TYP	MAX	UNIT
$f_{OUT}$	Output frequency		0.008		400	MHz
$V_{CM}$	Output common mode voltage, $V_{DDOX} = 2.5/3.3\text{ V}$	$R_L = 100\ \Omega$	1.125	1.2	1.275	V
	Output common mode voltage, $V_{DDOX} = 1.8\text{ V}$	$R_L = 100\ \Omega$		0.9		V
$ V_{OD} $	Differential output voltage	$R_L = 100\ \Omega$ , single-ended Pk-Pk	250	400	550	mV
$\Delta V_{OD}$	Change in magnitude of VOD for complementary output states	$R_L = 100\ \Omega$	-50		50	mV
$V_{ring}$	Output overshoot and undershoot	Percentage of output amplitude VOD			20%	
$V_{OS}$	Output AC common mode	$V_{IN, DIFF, PP} = 0.9\text{ V}$ , $R_L = 100\ \Omega$ , 2 pF			150	mVP-P
$T_{ADDJIT}$	Additive jitter <sup>(1)</sup>	$f_{out} = 100\text{ MHz}$ , 10k-20M integration bandwidth, $R_L = 100\ \Omega$			200	fs, rms
		$f_{out} = 400\text{ MHz}$ , 10k-20M integration bandwidth, $R_L = 100\ \Omega$			180	
$t_R/t_F$	Output rise/fall time	ERC = Slow, 20% to 80%, $Z_L = 100\ \Omega$ , 1pF, $V_{DDOX} = 3.3\text{ V}$		800		ps
		ERC = Slow, 20% to 80%, $Z_L = 100\ \Omega$ , 1pF, $V_{DDOX} = 1.8\text{ V}$		700		
		ERC = Medium., 20% to 80%, $Z_L = 100\ \Omega$ , 1pF, $V_{DDOX} = 3.3\text{ V}$		600		
		ERC = Medium., 20% to 80%, $Z_L = 100\ \Omega$ , 1pF, $V_{DDOX} = 1.8\text{ V}$		500		
		ERC = Fast, 20% to 80%, $Z_L = 100\ \Omega$ , 1 pF		300		
ODC	Output duty cycle	50/50 Input duty cycle	45%		55%	
$I_{SP}$ $I_{SN}$	Output short circuit current (single ended)	Shorted to GND	-24		24	mA
$ I_{PN} $	Output short circuit current (differential)	Complementary outputs shorted together			12	mA
$T_{DLYO}$	Propagation delay	ERC set to high rate. Input $t_r, t_f > 0.6\text{ V/ns}$ , $R_L = 100\ \Omega$ , $V_{DD} = 2.5\text{ V}, 3.3\text{ V}$			3.3	ns
		ERC set to high rate. Input $t_r, t_f > 0.6\text{ V/ns}$ , $R_L = 100\ \Omega$ , $V_{DD} = 1.8\text{ V}$			3.8	
$t_{SKEW}$	Skew between outputs	ERC set to high rate. Input $t_r, t_f > 0.6\text{ V/ns}$ , Equal $V_{DDOX}$ , $R_L = 100\ \Omega$		35	50	ps
$t_{OE}$	Output enable to stable clock output	Pin mode, $f_{out} = 100\text{ MHz}$ , device in active mode with outputs disabled, OE asserted		20		$\mu\text{s}$
$t_{PD}$	PD de-asserted to stable clock output	Host mode, $f_{out} = 100\text{ MHz}$ , device in power down mode, PD de-asserted		20		$\mu\text{s}$
$t_{PU}$	Time from power applied to stable clock output <sup>(2)</sup>	Pin mode, $f_{out} = 100\text{ MHz}$ , OE asserted, measured from time $V_{DD}$ is valid to stable output.		1		ms

(1)  $t_{Rfin} = t_{Ffin} > 0.6\text{ V/ns}$ .

(2) Parameter depends significantly on power supply design and supply voltage rise time.

## 6.8 Clock Output Buffer Characteristics (Output Mode = HCSL)

Unless otherwise noted,  $V_{DDOx} = 1.8\text{ V}, 2.5\text{ V}, 3.3\text{ V}$ ;  $T_A = -40^\circ\text{C}$  to  $85^\circ\text{C}$ . See [Figure 18](#), [Figure 19](#), and [Figure 20](#). Supporting PCIe Gen1, Gen2, Gen3.

PARAMETER		TEST CONDITIONS	MIN	TYP	MAX	UNIT
$f_{OUT}$	Output frequency		0.008		400	MHz
$V_{max}$	Absolute maximum output voltage <sup>(1)</sup>	See <a href="#">Figure 1</a>			1.15	V
$V_{min}$	Absolute minimum output voltage <sup>(2)</sup>	See <a href="#">Figure 1</a>	-0.3			V
$V_{OH}$	Single-ended output voltage – high <sup>(3)</sup>	$R_L = \text{single ended to GND} = 50\ \Omega, C_L = 2\ \text{pF}, V_{DDOx} = 2.5\ \text{V}, 3.3\ \text{V}$ See <a href="#">Figure 18</a>		600		mV
		$R_L = \text{single ended to GND} = 50\ \Omega, C_L = 2\ \text{pF}, V_{DDOx} = 1.8\ \text{V}$ See <a href="#">Figure 18</a>		550		
$V_{OL}$	Single-ended output voltage – low <sup>(3)</sup>	$R_L = \text{single ended to GND} = 50\ \Omega, C_L = 2\ \text{pF}$ , See <a href="#">Figure 18</a>			150	mV
$V_{CROSS}$	Output crossing point voltage <sup>(3)</sup>	See <a href="#">Figure 1</a>	250		550	mV
$V_{CROSS\Delta}$	$V_{CROSS}$ Total variation <sup>(3)</sup>	See <a href="#">Figure 2</a>			140	mV
$V_{RB}$	Ring back voltage margin <sup>(3)</sup>	See <a href="#">Figure 3</a>	-100		100	mV
$T_{STABLE}$	Time before $V_{RB}$ is Allowed <sup>(3), (4)</sup>	See <a href="#">Figure 3</a>	500			ps
$V_{OS}$	Output AC common mode	$V_{IN, DIFF, PP} = 0.9\ \text{V}, R_L = \text{single ended to GND} = 50\ \Omega, 2\ \text{pF}$		75	125	mV <sub>P-P</sub>
$T_{jitHCSL}$	Additive jitter, input set to HCSL <sup>(5)</sup>	$f_{OUT} = 100\ \text{MHz}$ , 10k-20M integration bandwidth. Differential measurement			380	fs, rms
$T_{jitLVDS}$	Additive jitter, input set to LVDS <sup>(5)</sup>	$f_{OUT} = 100\ \text{MHz}$ , 10k-20M integration bandwidth. Differential measurement			280	fs, rms
$t_R/t_F$	Output rise/fall time <sup>(6)</sup>	Slow, +150-mV differential, see <a href="#">Figure 4</a> , $V_{DDOx} = 3.3\ \text{V}$		300		ps
		Slow, +150-mV differential, see <a href="#">Figure 4</a> , $V_{DDOx} = 1.8\ \text{V}$		230		
		Med., +150-mV differential, see <a href="#">Figure 4</a> , $V_{DDOx} = 3.3\ \text{V}$		240		
		Med., +150-mV differential, see <a href="#">Figure 4</a> , $V_{DDOx} = 1.8\ \text{V}$		180		
		Fast, +150-mV differential, see <a href="#">Figure 4</a>		140		
$TM_{RF}$	Output rise/fall time matching	See <a href="#">Figure 5</a>			20%	
ODC	Output duty cycle <sup>(7)</sup>	Differential measurement, see <a href="#">Figure 6</a>	45%		55%	
$T_{DLYO}$	Propagation delay	ERC set to high rate. Input $t_r, t_f > 0.6\ \text{V/ns}$ , $V_{DD} = 2.5\ \text{V}, 3.3\ \text{V}$			3.8	ns
		ERC set to high rate. Input $t_r, t_f > 0.6\ \text{V/ns}$ , $V_{DD} = 1.8\ \text{V}$			4.3	
$t_{SKEW}$	Skew between outputs <sup>(8)</sup>	Differential Measurement, Input $t_r, t_f > 0.6\ \text{V/ns}$		35	50	ps
$t_{OE}$	Output enable to stable clock output	Pin mode, $f_{out} = 100\ \text{MHz}$ , device in active mode with outputs disabled, OE asserted		2		$\mu\text{s}$
$t_{PD}$	PD de-asserted to stable clock output	Host mode, $f_{out} = 100\ \text{MHz}$ , device in power down mode, PD de-asserted		15		$\mu\text{s}$
$t_{PU}$	Time from power applied to stable clock output <sup>(9)</sup>	Pin mode, $f_{out} = 100\ \text{MHz}$ , OE asserted, measured from time $V_{DD}$ is valid to stable output		1		ms

- (1) Single-ended measurement includes overshoot. Measurement is taken at load capacitors  $C_L$  (see [Figure 18](#)).
- (2) Single-ended measurement, includes undershoot. Measurement is taken at load capacitors  $C_L$  (see [Figure 18](#)).
- (3) Measurement is taken at load capacitors  $C_L$  (see [Figure 18](#)). If  $V_{DDOx} = 1.8\ \text{V}$ , the specified minimum  $V_{OH}$  is 550 mV.
- (4)  $T_{STABLE}$  is the time the differential clock must maintain a minimum  $\pm 150\ \text{mV}$  differential voltage after rising/falling edges, before it is allowed to return into the  $VRB \pm 100\ \text{mV}$  differential range. See [Figure 3](#).
- (5)  $t_{Rfin} = t_{Ffin} \geq 0.6\ \text{V/ns}$ .
- (6) Measured from  $-150\ \text{mV}$  to  $+150\ \text{mV}$  on the differential waveform. The signal must be monotonic through the measurement region for rise and fall time. The 300-mV measurement window is centered on the differential zero crossing. Slow is  $0.53\ \text{V/ns}$ , medium is  $1.05\ \text{V/ns}$ , and fast is  $2.1\ \text{V/ns}$ . The PCIe CEM spec. has a window of  $0.6\ \text{V/ns}$  to  $4\ \text{V/ns}$ .
- (7) Assumes input duty cycle = 50%.
- (8) Skew measured between identical output types with identical loads, identical output power supplies, and identical edge rate settings.
- (9) Parameter depends significantly on power supply design and supply voltage rise time.

## 6.9 Clock Output Buffer Electrical Characteristics (Output Mode = LVCMOS)

Unless otherwise noted,  $V_{DDOx}$  as shown in Table sections,  $T_A = -40^{\circ}\text{C}$  to  $85^{\circ}\text{C}$ . ERC = Fast. For test configurations, see [Figure 21](#) and [Figure 22](#).

PARAMETER	TEST CONDITIONS	MIN	TYP	MAX	UNIT
<b>3.3-V MODE</b>					
$f_{out}$	Output frequency range	0.0008		250	MHz
$V_{OH}$	LVCMOS high-level output voltage	$V_{DDOx} = 2.97\text{ V}$ , $I_{OH} = -0.1\text{ mA}$ (All ERC Settings)		2.9	V
		$V_{DDOx} = 2.97\text{ V}$ , $I_{OH} = -5\text{ mA}$ (ERC = SLOW)		2.4	V
		$V_{DDOx} = 2.97\text{ V}$ , $I_{OH} = -8\text{ mA}$ (ERC = MED, FAST)			
		$V_{DDOx} = 2.97\text{ V}$ , $I_{OH} = -6\text{ mA}$ (ERC = SLOW)		2.2	V
		$V_{DDOx} = 2.97\text{ V}$ , $I_{OH} = -10\text{ mA}$ (ERC = MED)			
		$V_{DDOx} = 2.97\text{ V}$ , $I_{OH} = -12\text{ mA}$ (ERC = FAST)			
$V_{OL}$	LVCMOS low-level output voltage	$V_{DDOx} = 2.97\text{ V}$ , $I_{OL} = 0.1\text{ mA}$ (All ERC Settings)		0.1	V
		$V_{DDOx} = 2.97\text{ V}$ , $I_{OL} = 5\text{ mA}$ (ERC = SLOW)		0.5	V
		$V_{DDOx} = 2.97\text{ V}$ , $I_{OL} = 8\text{ mA}$ (ERC = MED, FAST)			
		$V_{DDOx} = 2.97\text{ V}$ , $I_{OL} = 6\text{ mA}$ (ERC = SLOW)		0.8	V
		$V_{DDOx} = 2.97\text{ V}$ , $I_{OL} = 10\text{ mA}$ (ERC = MED)			
		$V_{DDOx} = 2.97\text{ V}$ , $I_{OL} = 12\text{ mA}$ (ERC = FAST)			
$I_{OH}$	LVCMOS high-level output current	$V_{DDOx} = 3.3\text{ V}$ , $V_O = 0.5\text{ V}$ ; $T_A = 25^{\circ}\text{C}$		-73	mA
		$V_{DDOx} = 3.3\text{ V}$ , $V_O = 1.0\text{ V}$ ; $T_A = 25^{\circ}\text{C}$		-64	
		$V_{DDOx} = 3.3\text{ V}$ , $V_O = 1.65\text{ V}$ ; $T_A = 25^{\circ}\text{C}$		-49	
$I_{OL}$	LVCMOS low-level output current	$V_{DDOx} = 3.3\text{ V}$ , $V_O = 2.8\text{ V}$ ; $T_A = 25^{\circ}\text{C}$		78	mA
		$V_{DDOx} = 3.3\text{ V}$ , $V_O = 2.3\text{ V}$ ; $T_A = 25^{\circ}\text{C}$		72	
		$V_{DDOx} = 3.3\text{ V}$ , $V_O = 1.65\text{ V}$ ; $T_A = 25^{\circ}\text{C}$		58	
$t_{PLH}$ , $t_{PHL}$	Propagation delay		5		ns
$t_{SLEW-RATE}$	Output rise/fall slew rate	ERC = Slow, 20% to 80%, $f_{out} = 100\text{ MHz}$ , $C_L = 8\text{ pF}$		1.2	V/ns
		ERC = Medium 20% to 80%, $f_{out} = 100\text{ MHz}$ , $C_L = 8\text{ pF}$		3	
		ERC = Fast, 20% to 80%, $f_{out} = 250\text{ MHz}$ , $C_L = 8\text{ pF}$		6	
$t_{jitt-add}$	Additive jitter	$f_{OUT} = 100\text{ MHz}$ , 10k-20M integration bandwidth		280	fs
$t_{sk(o)}$	Output skew <sup>(1)</sup>			90	ps
odc	Output duty cycle <sup>(2), (3)</sup>	$f_{OUT} = 100\text{ MHz}$ ; Pdiv = 1		45%	55%
$t_{OE}$	Output enable to stable clock output	Pin mode, $f_{out} = 100\text{ MHz}$ , device in active mode with outputs disabled, OE asserted		2	$\mu\text{s}$
$t_{PD}$	PD de-asserted to stable clock output	Host mode, $f_{out} = 100\text{ MHz}$ , device in power down mode, PD de-asserted		10	$\mu\text{s}$
$t_{PU}$	Time from power applied to stable clock output <sup>(4)</sup>	Pin mode, $f_{out} = 100\text{ MHz}$ , OE asserted, measured from time $V_{DD}$ is valid to stable output.		1	ms

(1) The  $t_{sk(o)}$  specification is only valid for equal loading with identical edge rates and output supply voltages.

(2) Assumes 50% duty cycle at the input.

(3) odc depends on output rise and fall time ( $t_R/t_F$ ).

(4) Parameter depends significantly on power supply design and supply voltage rise time.

### 6.10 Clock Output Buffer Electrical Characteristics (Output Mode = LVCMOS) (Continued)

Unless otherwise noted,  $V_{DDOX}$  as shown in Table sections,  $T_A = -40^{\circ}\text{C}$  to  $85^{\circ}\text{C}$ . ERC = Fast. For test configurations, see Figure 21 and Figure 22.

PARAMETER	TEST CONDITIONS	MIN	TYP	MAX	UNIT
<b>2.5-V MODE</b>					
$f_{out}$	Output frequency range	0.0008		250	MHz
$V_{OH}$	LVCMOS high-level output voltage	$V_{DDOX} = 2.375\text{ V}$ , $I_{OH} = -0.1\text{ mA}$ (All ERC Settings)		2.2	
		$V_{DDOX} = 2.375\text{ V}$ , $I_{OH} = -4\text{ mA}$ (ERC = SLOW)		1.7	V
		$V_{DDOX} = 2.375\text{ V}$ , $I_{OH} = -6\text{ mA}$ (ERC = MED, FAST)			
		$V_{DDOX} = 2.375\text{ V}$ , $I_{OH} = -5\text{ mA}$ (ERC = SLOW)		1.6	V
$V_{OL}$	LVCMOS low-level output voltage	$V_{DDOX} = 2.375\text{ V}$ , $I_{OL} = 0.1\text{ mA}$ (All ERC Settings)			0.1
		$V_{DDOX} = 2.375\text{ V}$ , $I_{OH} = 4\text{ mA}$ (ERC = SLOW)			0.5
		$V_{DDOX} = 2.375\text{ V}$ , $I_{OH} = 6\text{ mA}$ (ERC = MED, FAST)			
		$V_{DDOX} = 2.375\text{ V}$ , $I_{OH} = 5\text{ mA}$ (ERC = SLOW)			0.7
$I_{OH}$	LVCMOS high-level output current	$V_{DDOX} = 2.5\text{ V}$ , $V_O = 0.5\text{ V}$ ; $T_A = 25^{\circ}\text{C}$			-45
		$V_{DDOX} = 2.5\text{ V}$ , $V_O = 0.9\text{ V}$ ; $T_A = 25^{\circ}\text{C}$			-39
		$V_{DDOX} = 2.5\text{ V}$ , $V_O = 1.25\text{ V}$ ; $T_A = 25^{\circ}\text{C}$			-32
$I_{OL}$	LVCMOS low-level output current	$V_{DDOX} = 2.5\text{ V}$ , $V_O = 2.0\text{ V}$ ; $T_A = 25^{\circ}\text{C}$			50
		$V_{DDOX} = 2.5\text{ V}$ , $V_O = 1.65\text{ V}$ ; $T_A = 25^{\circ}\text{C}$			47
		$V_{DDOX} = 2.5\text{ V}$ , $V_O = 1.25\text{ V}$ ; $T_A = 25^{\circ}\text{C}$			40
$t_{PLH}$ , $t_{PHL}$	Propagation delay		5.5		ns
$t_{SLEW-RATE}$	Output rise/fall slew rate	ERC = Slow, 20% to 80%, $f_{out} = 100\text{ MHz}$ , $C_L = 8\text{ pF}$		0.8	
		ERC = Medium 20% to 80%, $f_{out} = 100\text{ MHz}$ , $C_L = 8\text{ pF}$		1.4	V/ns
		ERC = Fast, 20% to 80%, $f_{out} = 250\text{ MHz}$ , $C_L = 8\text{ pF}$		4	
$t_{jit-add}$	Additive jitter	$f_{OUT} = 100\text{ MHz}$ , 10k-20M integration bandwidth		280	fs
$t_{sk(o)}$	Output skew <sup>(1)</sup>			90	ps
odc	Output duty cycle <sup>(2)(3)</sup>	$f_{OUT} = 100\text{ MHz}$ ; Pdiv = 1		45%	55%
$t_{OE}$	Output enable to stable clock output	Pin mode, $f_{out} = 100\text{ MHz}$ , device in active mode with outputs disabled, OE asserted		2	$\mu\text{s}$
$t_{PD}$	PD de-asserted to stable clock output	Host mode, $f_{out} = 100\text{ MHz}$ , device in power down mode, PD de-asserted		10	$\mu\text{s}$
$t_{PU}$	Time from power applied to stable clock output <sup>(4)</sup>	Pin mode, $f_{out} = 100\text{ MHz}$ , OE asserted, measured from time $V_{DD}$ is valid to stable output.		1	ms

- (1) The  $t_{sk(o)}$  specification is only valid for equal loading with identical edge rates and output supply voltages.
- (2) Assumes 50% duty cycle at the input.
- (3) odc depends on output rise and fall time ( $t_R/t_F$ ).
- (4) Parameter depends significantly on power supply design and supply voltage rise time.

### 6.11 Clock Output Buffer Electrical Characteristics (Output Mode = LVCMOS) (Continued)

Unless otherwise noted,  $V_{DDOx}$  as shown in Table sections,  $T_A = -40^{\circ}\text{C}$  to  $85^{\circ}\text{C}$ . ERC = Fast. For test configurations, see Figure 21 and Figure 22.

PARAMETER	TEST CONDITIONS	MIN	TYP	MAX	UNITS
<b>1.8-V MODE</b>					
$f_{out}$	Output frequency range	0.0008		250	MHz
$V_{OH}$	LVCMOS high-level output voltage	$V_{DDOx} = 1.7\text{ V}$ , $I_{OH} = -0.1\text{ mA}$ (All ERC Settings)	1.6		V
		$V_{DDOx} = 1.7\text{ V}$ , $I_{OH} = -1.5\text{ mA}$ (ERC = SLOW)			
		$V_{DDOx} = 1.7\text{ V}$ , $I_{OH} = -3\text{ mA}$ (ERC = MED)	1.4		V
		$V_{DDOx} = 1.7\text{ V}$ , $I_{OH} = -4\text{ mA}$ (ERC = FAST)			
		$V_{DDOx} = 1.7\text{ V}$ , $I_{OH} = -3\text{ mA}$ (ERC = SLOW)			
		$V_{DDOx} = 1.7\text{ V}$ , $I_{OH} = -5\text{ mA}$ (ERC = MED)	1.1		
$V_{DDOx} = 1.7\text{ V}$ , $I_{OH} = -8\text{ mA}$ (ERC = FAST)					
$V_{OL}$	LVCMOS low-level output voltage	$V_{DDOx} = 1.7\text{ V}$ , $I_{OL} = 0.1\text{ mA}$ (All ERC Settings)		0.1	V
		$V_{DDOx} = 1.7\text{ V}$ , $I_{OL} = 2\text{ mA}$ (ERC = SLOW)			V
		$V_{DDOx} = 1.7\text{ V}$ , $I_{OL} = 3\text{ mA}$ (ERC = MED)		0.3	
		$V_{DDOx} = 1.7\text{ V}$ , $I_{OL} = 4\text{ mA}$ (ERC = FAST)			V
		$V_{DDOx} = 1.7\text{ V}$ , $I_{OL} = 3\text{ mA}$ (ERC = SLOW)			
		$V_{DDOx} = 1.7\text{ V}$ , $I_{OL} = 5\text{ mA}$ (ERC = MED)		0.6	
$V_{DDOx} = 1.7\text{ V}$ , $I_{OL} = 8\text{ mA}$ (ERC = FAST)					
$I_{OH}$	LVCMOS high-level output current	$V_{DDOx} = 1.8\text{ V}$ , $V_O = 0.5\text{ V}$ ; $T_A = 25^{\circ}\text{C}$		-23	mA
		$V_{DDOx} = 1.8\text{ V}$ , $V_O = 0.9\text{ V}$ ; $T_A = 25^{\circ}\text{C}$		-18	
$I_{OL}$	LVCMOS low-level output current	$V_{DDOx} = 1.8\text{ V}$ , $V_O = 1.4\text{ V}$ ; $T_A = 25^{\circ}\text{C}$		27	mA
		$V_{DDOx} = 1.8\text{ V}$ , $V_O = 0.9\text{ V}$ ; $T_A = 25^{\circ}\text{C}$		23	
$t_{PLH}$ , $t_{PHL}$	Propagation delay		6.8		ns
$t_{SLEW-RATE}$	Output rise/fall slew rate	ERC = Slow, 20% to 80%, $f_{out} = 100\text{ MHz}$ , $C_L = 8\text{ pF}$		0.5	V/ns
		ERC = Medium 20% to 80%, $f_{out} = 100\text{ MHz}$ , $C_L = 8\text{ pF}$		0.8	
		ERC = Fast, 20% to 80%, $f_{out} = 250\text{ MHz}$ , $C_L = 8\text{ pF}$		2.7	
$t_{jitt-add}$	Additive jitter	$f_{OUT} = 100\text{ MHz}$ , 10k-20M integration bandwidth		350	fs
$t_{sk(o)}$	Output skew <sup>(1)</sup>			130	ps
odc	Output duty cycle <sup>(2), (3)</sup>	$f_{OUT} = 100\text{ MHz}$ ; Pdiv = 1, ERC = MED, FAST	45%	55%	
$t_{OE}$	Output enable to stable clock output	Pin mode, $f_{out} = 100\text{ MHz}$ , device in active mode with outputs disabled, OE asserted		2	$\mu\text{s}$
$t_{PD}$	PD de-asserted to stable clock output	Host mode, $f_{out} = 100\text{ MHz}$ , device in power down mode, PD de-asserted		10	$\mu\text{s}$
$t_{PU}$	Time from power applied to stable clock output <sup>(4)</sup>	Pin mode, $f_{out} = 100\text{ MHz}$ , OE asserted, measured from time $V_{DD}$ is valid to stable output.		1	ms

- (1) The  $t_{sk(o)}$  specification is only valid for equal loading with identical edge rates and output supply voltages.
- (2) Assumes 50% duty cycle at the input.
- (3) odc depends on output rise and fall time ( $t_R/t_F$ ).
- (4) Parameter depends significantly on power supply design and supply voltage rise time.

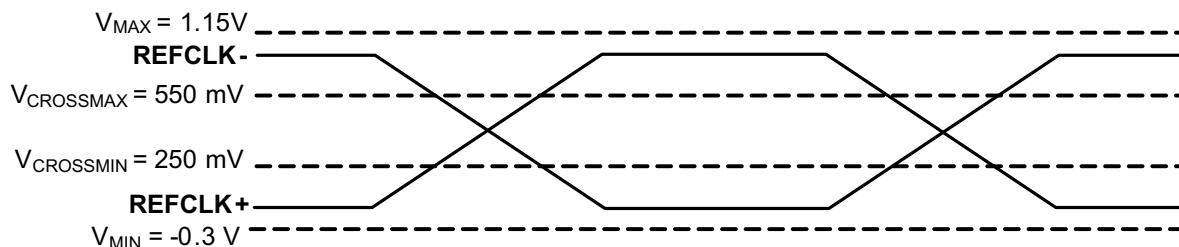

Figure 1. HCSL Crossing Point Voltage

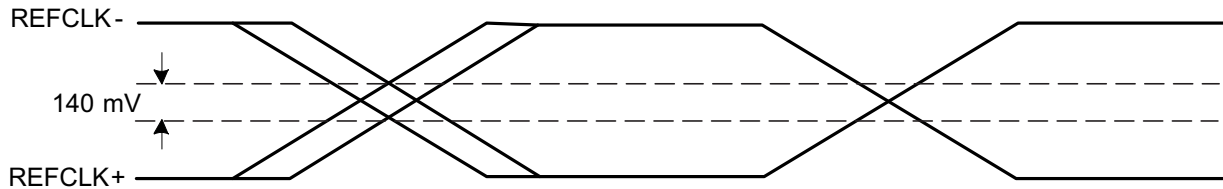

Figure 2. HCSL Variation of VCROSS Over All Rising Clock Edges

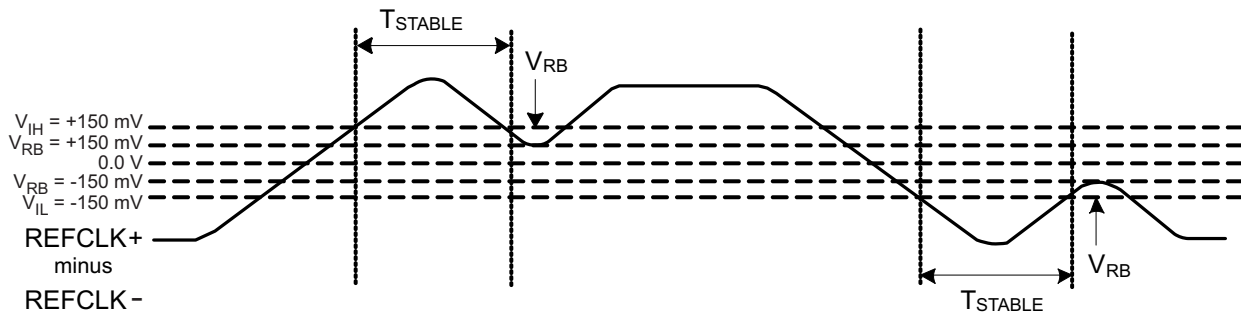

Figure 3. HCSL Ring Back Margin and Timing

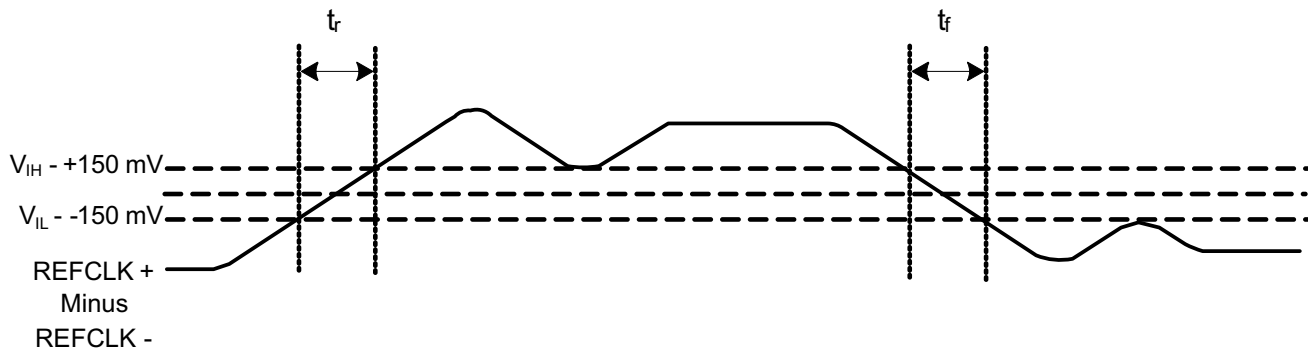

Figure 4. HCSL Rise Fall Time and Edge Speed

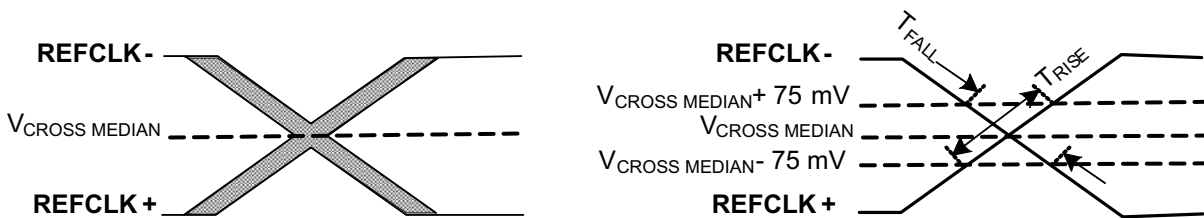

Figure 5. HCSL Rise Fall Time Matching

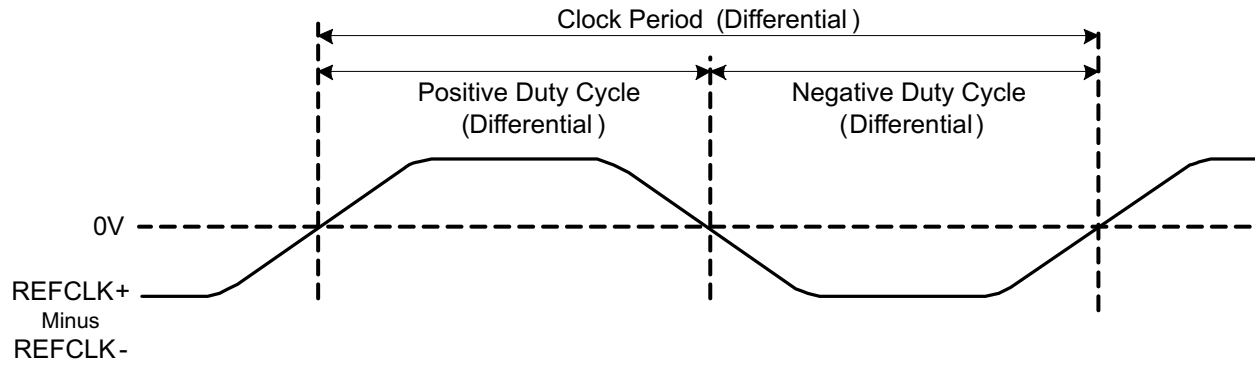

Figure 6. HCSL Duty Cycle

## 6.12 Typical Characteristics

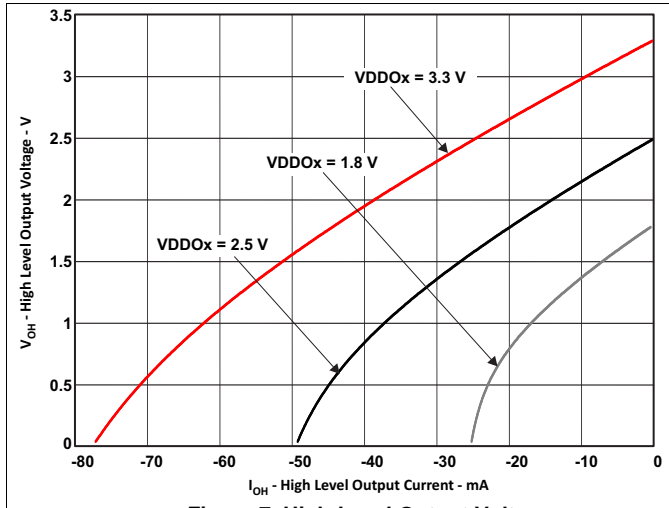

Figure 7. High-Level Output Voltage vs Current - LVC MOS Mode

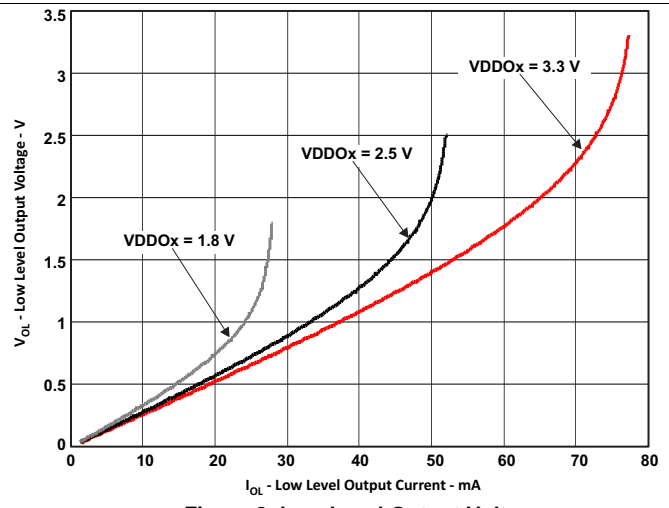

Figure 8. Low-Level Output Voltage vs Current - LVC MOS Mode

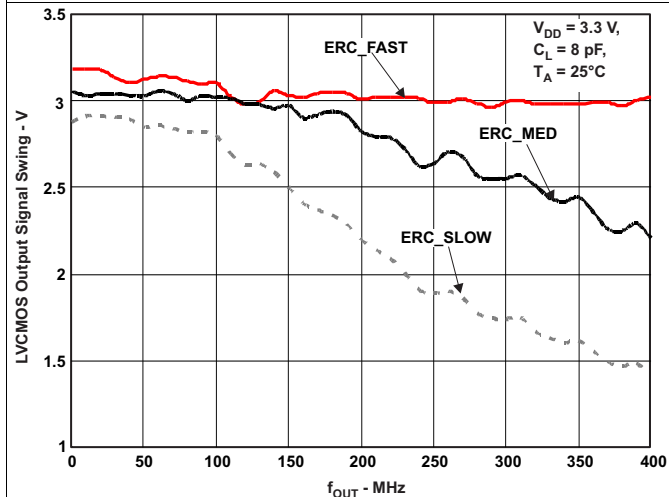

Figure 9. CDCUN1208LP LVC MOS Signal Swing Characteristics (3.3-V Mode)

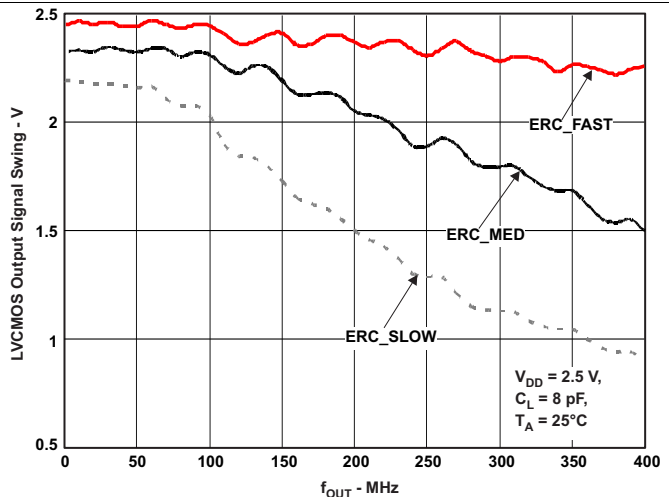

Figure 10. CDCUN1208LP LVC MOS Signal Swing Characteristics (2.5-V Mode)

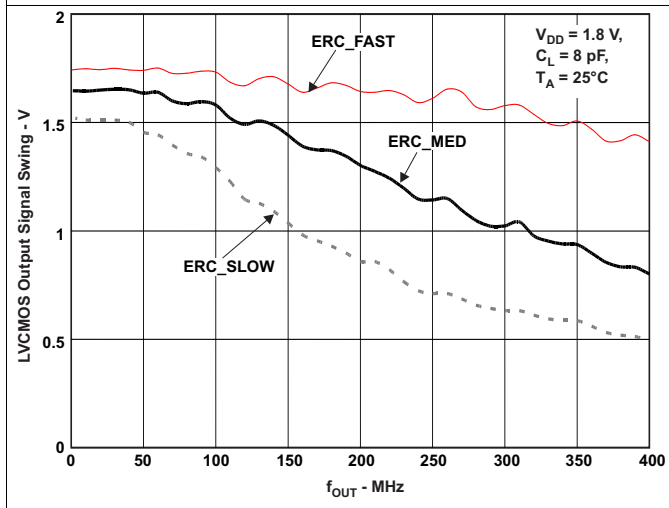

Figure 11. CDCUN1208LP LVC MOS Signal Swing Characteristics (1.8-V Mode)

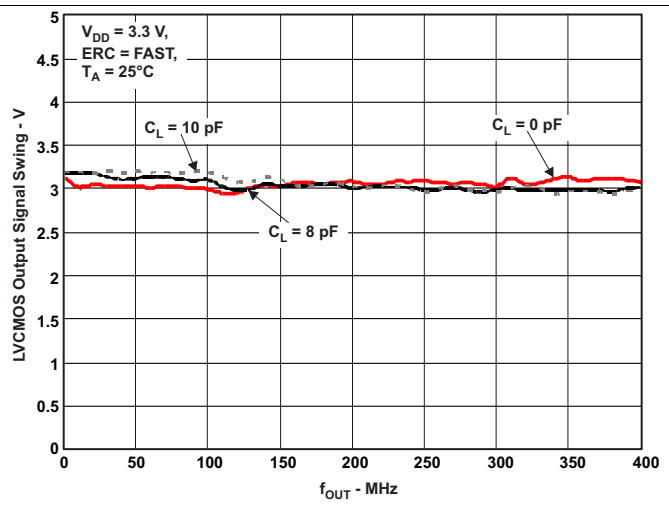
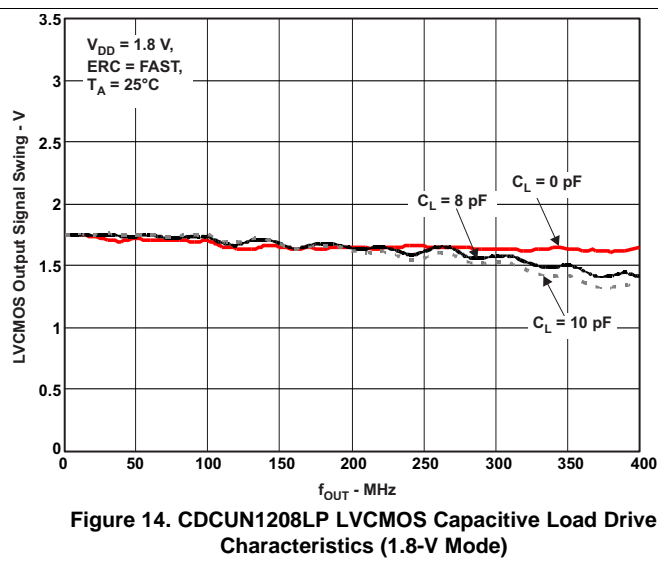
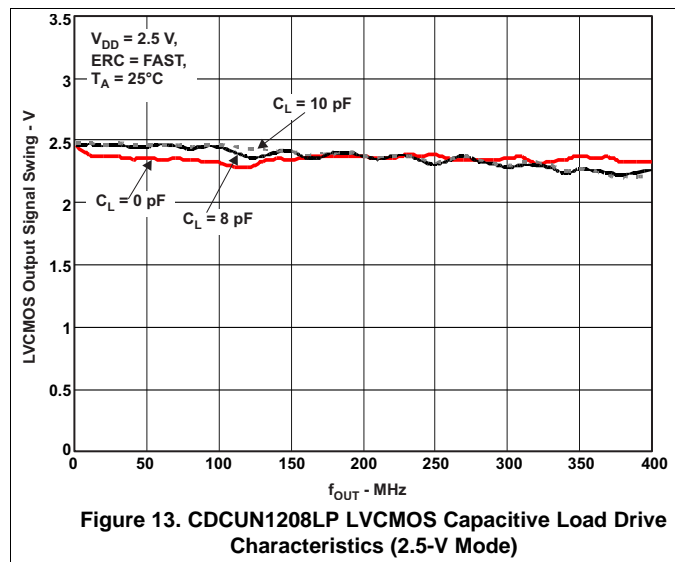

Figure 12. CDCUN1208LP LVC MOS Capacitive Load Drive Characteristics (3.3-V Mode)



Typical Characteristics (continued)



## 7 Parameter Measurement Information

### 7.1 Test Configurations

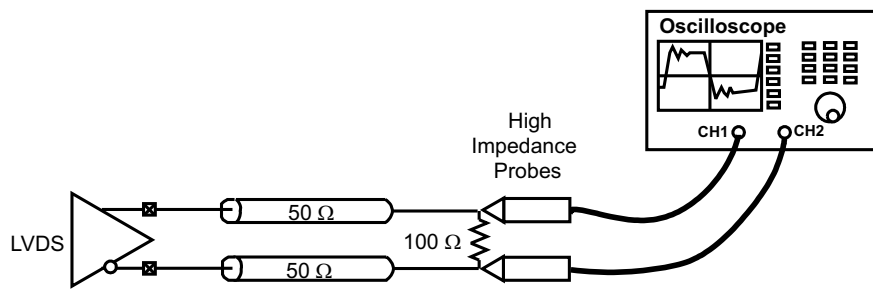

Copyright © 2017, Texas Instruments Incorporated

Figure 15. CDCUN1208LP LVDS Output - Test Setup

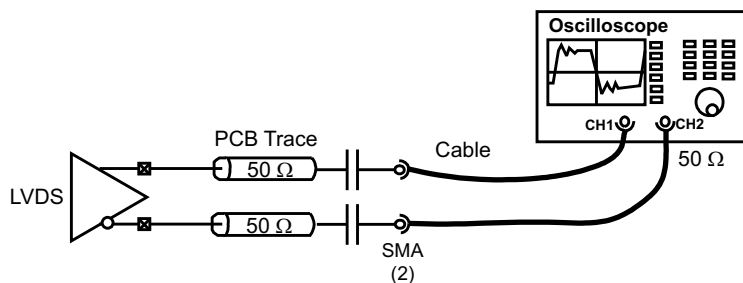

Copyright © 2017, Texas Instruments Incorporated

Figure 16. CDCUN1208LP LVDS Output - Propagation Delay/Skew Measurement Setup

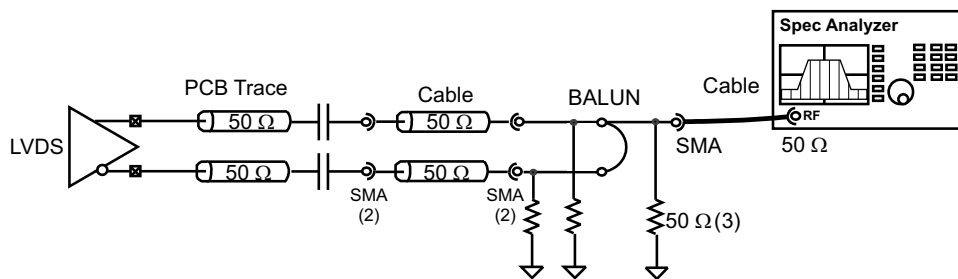

Copyright © 2017, Texas Instruments Incorporated

Figure 17. CDCUN1208LP LVDS Output - Phase Noise/Jitter Measurement Setup

Figure 18 shows the configuration used to measure the HCSL buffer characteristics. Either single-ended probes with math or differential probes can be used for differential measurements. The 50- $\Omega$  differential trace length is up to 15 inches.

Test Configurations (continued)

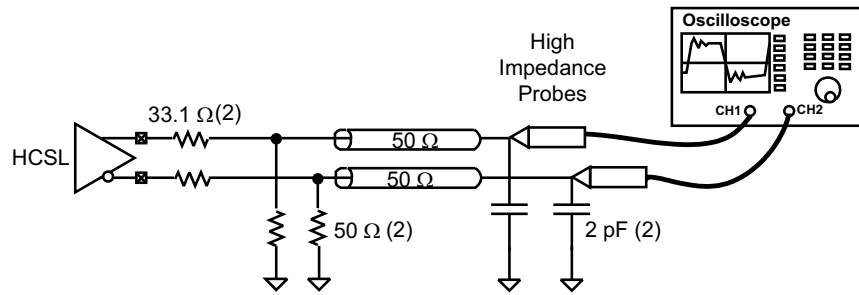

Copyright © 2017, Texas Instruments Incorporated

Figure 18. CDCUN1208LP HCSL Output – Measurement Configuration With Load

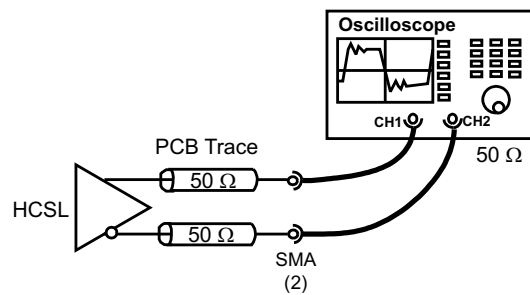

Copyright © 2017, Texas Instruments Incorporated

Figure 19. CDCUN1208LP HCSL Output – Propagation Delay/Skew Measurement

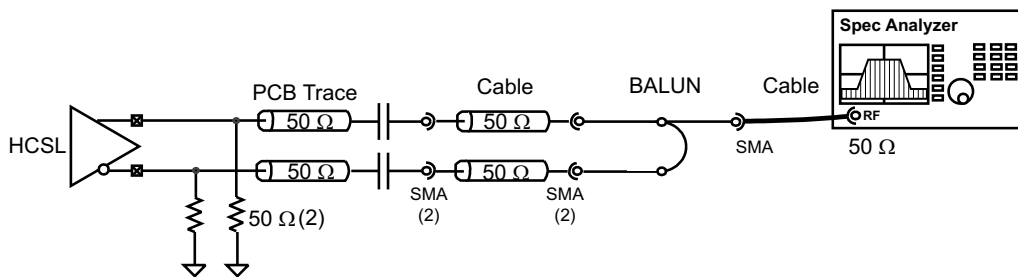

Copyright © 2017, Texas Instruments Incorporated

Figure 20. CDCUN1208LP HCSL Output – Phase Noise/Jitter Measurement Configuration

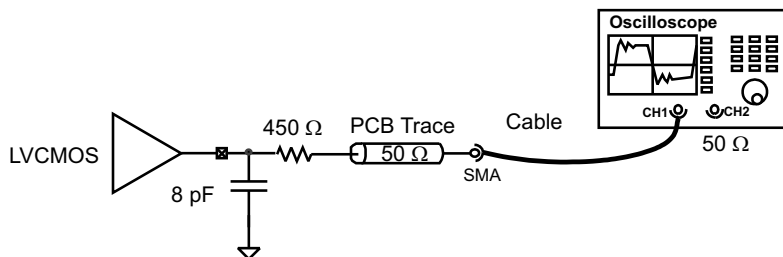

Copyright © 2017, Texas Instruments Incorporated

Figure 21. CDCUN1208LP LVCMOS Output – Measurement Configuration

Test Configurations (continued)

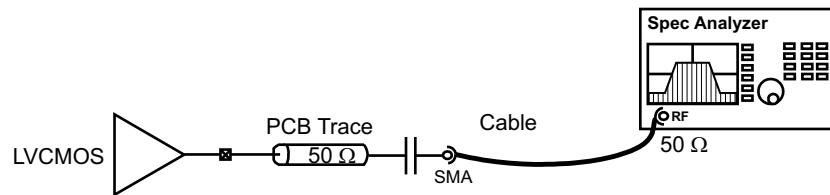

Copyright © 2017, Texas Instruments Incorporated

Figure 22. CDCUN1208LP LVC MOS Output – Phase Noise/Jitter Measurement Setup

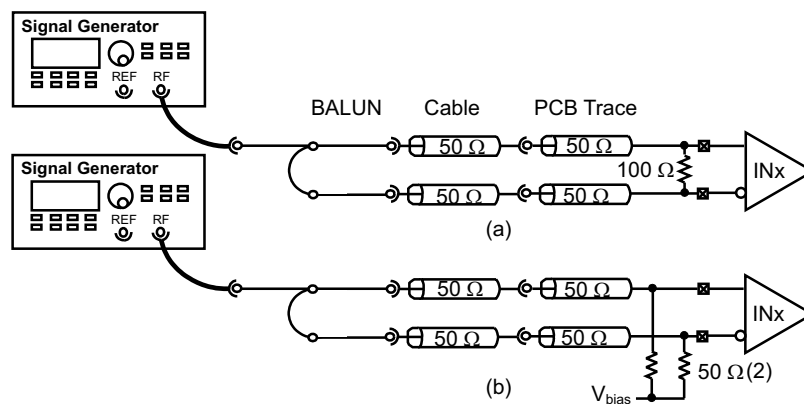

Copyright © 2017, Texas Instruments Incorporated

Figure 23. CDCUN1208LP Universal Input - Differential Mode Measurement Setup

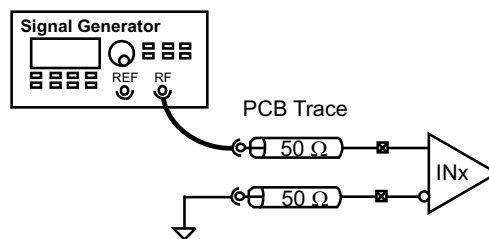

Copyright © 2017, Texas Instruments Incorporated

Figure 24. CDCUN1208LP Universal Input - Single-Ended Mode Measurement Setup

Test Configurations (continued)

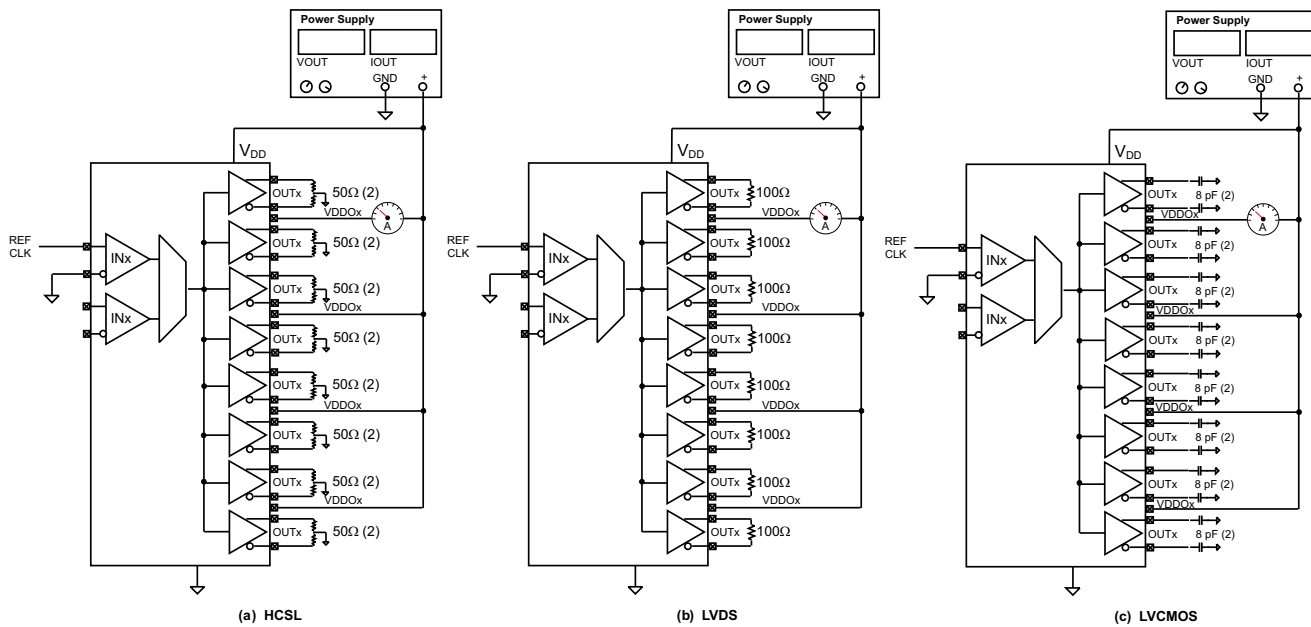

Copyright © 2017, Texas Instruments Incorporated

Figure 25. CDCUN1208LP Power Consumption Measurement Setup

## 8 Detailed Description

### 8.1 Overview

The CDCUN1208LP is a 2:8 fan-out buffer featuring a wide operating supply range, two universal differential or single-ended inputs, and universal outputs (HCSL, LVDS, or LVC MOS) with edge rate control. The clock buffer supports PCIe Gen1, Gen2, and Gen3. One of the device inputs includes a divider that provides divide values of  $/1$ ,  $/2$ ,  $/4$ , or  $/8$ . The device is flexible and easy to use. The state of certain pins determines device configuration at power up. Alternately, the CDCUN1208LP provides a SPI/I2C port with which a host processor controls device settings. The CDCUN1208LP delivers excellent additive jitter performance, and low power consumption. The device can run in mixed output supply mode with a dedicated supply pin for each group of outputs. This allows the device to work as an LVC MOS-level translator as well.

### 8.2 Functional Block Diagrams

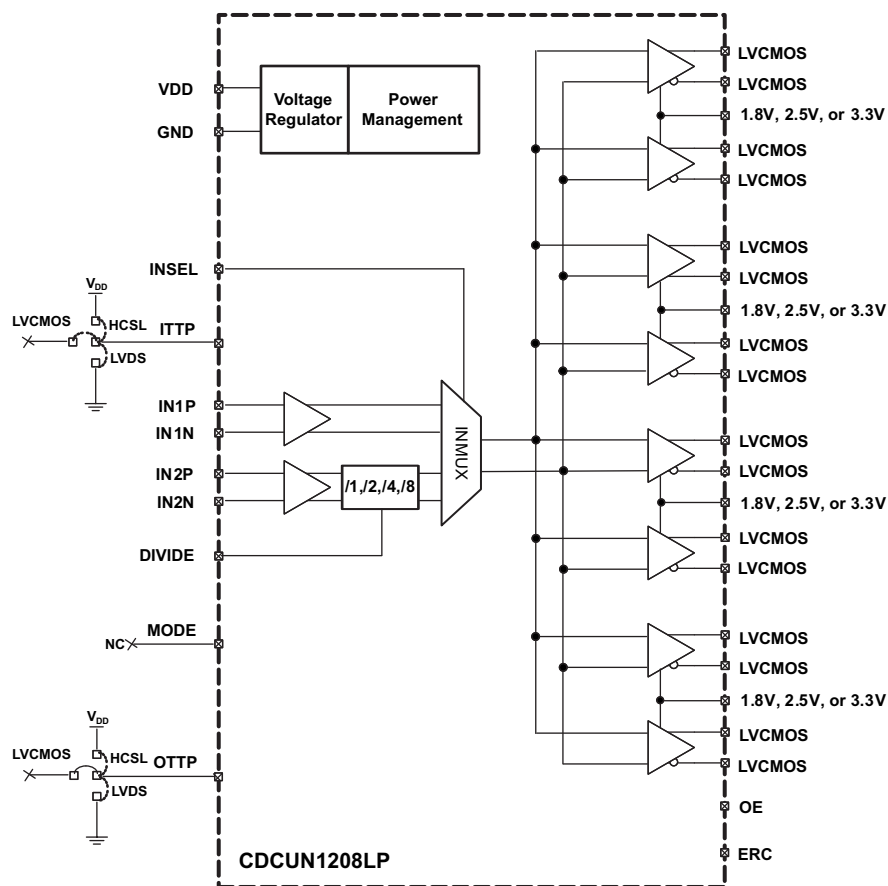

Copyright © 2017, Texas Instruments Incorporated

**Figure 26. CDCUN1208LP Typical Application Example – LVC MOS Output Mode**

Functional Block Diagrams (continued)

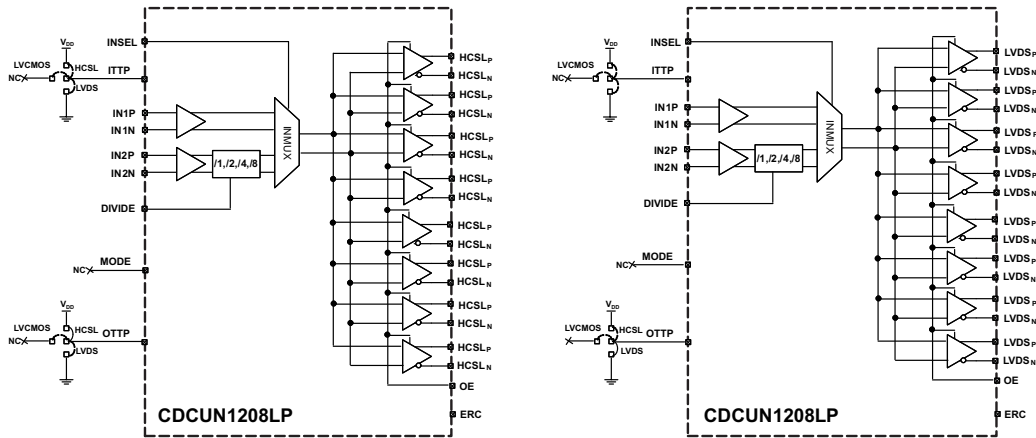

Copyright © 2017, Texas Instruments Incorporated

Figure 27. CDCUN1208LP Applications – HCSL and LVDS Fan-Out Buffer Mode

8.3 Feature Description

8.3.1 Device Control Using Configuration Pins

Figure 28 illustrates and Table 1 lists the CDCUN1208LP device settings using the configuration pins. Some pins sense three different states (HIGH, LOW, OPEN) according to Figure 28 and Digital Input Electrical Characteristics – OE (SCL), INSEL, ITTP, OTTP, Divide (SDA/MOSI), ERC(ADDR/CS), Mode. The device samples the state of the pins at power up and configures the device accordingly. Certain pins including INSEL and OE are sampled continuously; thus, changes of state of INSEL or OE control the device instantly.

Feature Description (continued)

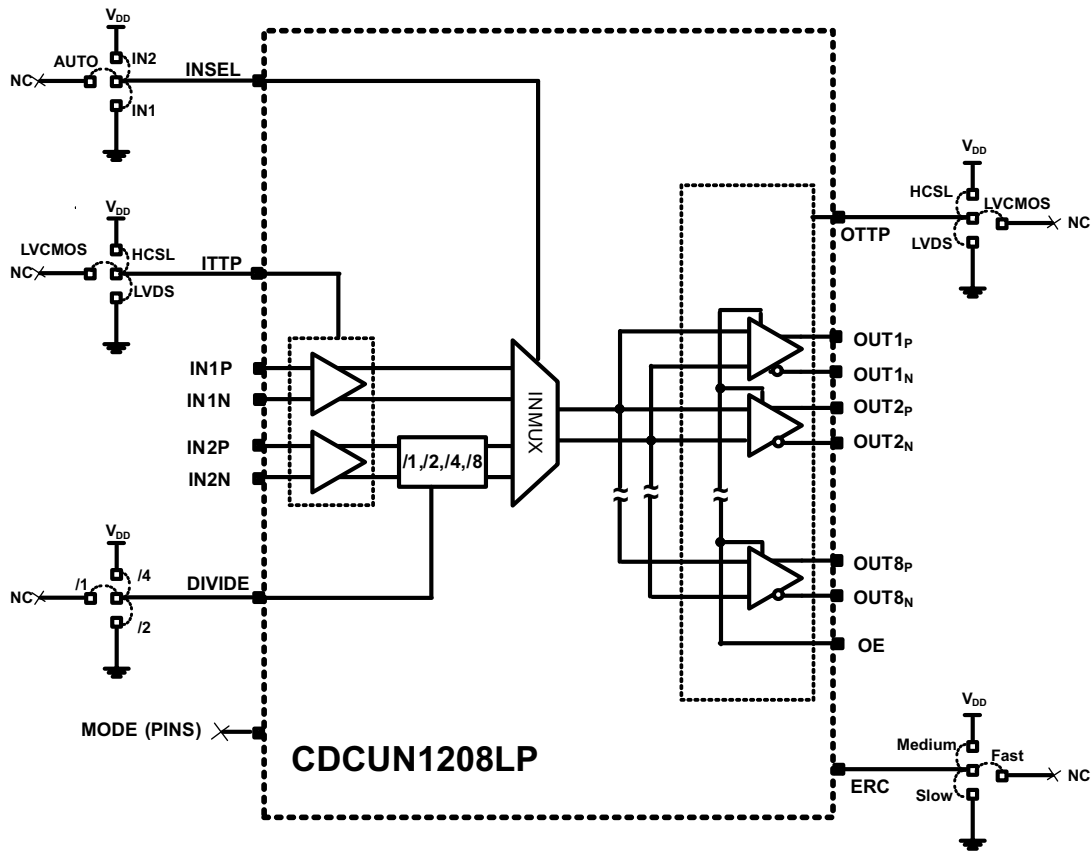

Copyright © 2017, Texas Instruments Incorporated

Figure 28. CDCUN1208LP Pin Configuration Overview

Table 1. CDCUN1208LP Pin Configuration Summary

PIN NAME	PIN NUMBER	DEFINITION	DEVICE CONFIGURATION DETAILS
<b>DEVICE OUTPUTS</b>			
OTTP	19	Output type setting	See <a href="#">Table 2</a>
ERC	31	Edge rate control	See <a href="#">Table 3</a>
OE	32	Device global output enable	See <a href="#">Table 4</a>
<b>DEVICE INPUTS</b>			
ITTP	8	Input type setting	See <a href="#">Table 5</a>
DIVIDE	1	IN2 input divider control	See <a href="#">Table 6</a>
INSEL	2	Input multiplexer setting	See <a href="#">Table 7</a>



### 8.3.1.1 Configuration of Output Type (OTTP)

Table 2 shows how to set the output buffer type using the OTTP pin. This setting affects all device outputs equally. Certain combinations of output buffers include a dedicated power supply pin, which must be properly bypassed. If the device output configuration is set to LVCMOS, then the supply voltage applied establishes the switching thresholds corresponding to the supply provided according to [Clock Output Buffer Electrical Characteristics \(Output Mode = LVCMOS\)](#). For example, if OUT1 and OUT2 are supplied with a 1.8-V power supply through the VDDO1 pin, the switching thresholds are set to the 1.8-V logic domain. The system may have other logic supplies (1.8 V, 2.5 V, or 3.3 V) connected to the device on different output buffer supply domains simultaneously. This enables the device to clock devices operating on different supplies, without the need for external logic level translation buffers. The CDCUN1208LP automatically adjusts the switching thresholds corresponding to these common logic power supply voltages. For more information regarding the power supplies for the output section, see [Device Power Supply Connections and Sequencing](#).

**Table 2. CDCUN1208LP Pin Configuration of Output Type**

OTTP (Pin 19)	OUTPUT TYPE
LOW	LVDS
HIGH	HCSL
OPEN	LVCMOS

### 8.3.1.2 Configuration of Edge Rate Control (ERC)

The CDCUN1208LP supports Edge Rate Control (ERC), to tailor jitter and EMI performance from device outputs. Table 3 shows the edge rate control setting. This setting affects all device outputs equally. Each edge rate setting is unique to the output buffer type selected as described in [Clock Output Buffer Characteristics \(Output Mode = LVDS\)](#), [Clock Output Buffer Characteristics \(Output Mode = HCSL\)](#), and [Clock Output Buffer Electrical Characteristics \(Output Mode = LVCMOS\)](#).

**Table 3. CDCUN1208LP Pin Configuration of Output Edge Rate**

ERC (Pin 31)	OUTPUT EDGE RATE
LOW	SLOW
HIGH	MEDIUM
OPEN	FAST

### 8.3.1.3 Control of Output Enable (OE)

Table 4 shows how the output enable pin controls the device outputs. The OE pin is sampled continuously, so that the application may turn on/off the output buffers at any time.

**Table 4. CDCUN1208LP Pin Control of Output Enable**

OE (Pin 32)	OUTPUT ENABLE
LOW	DISABLED in tri-state
HIGH	ENABLED
OPEN	RESERVED <sup>(1)</sup>

- (1) Leaving the Output Enable pin OPEN causes the CDCUN1208LP to malfunction. This pin must be driven high or low at all times.

### 8.3.2 Input Ports (IN1, IN2)

#### 8.3.2.1 Configuration of the Input Type (ITTP)

Table 5 describes how to set the input buffers to the appropriate switching levels using the ITTP pin. For proper input termination, see Figure 46.

**Table 5. CDCUN1208LP Pin Control of Input Type (ITTP)**

ITTP (Pin 8)	ITTP SETTING
LOW	LVDS
HIGH	HCSL
OPEN	LVC MOS

#### 8.3.2.2 Configuration of the IN2 Divider (INDIV)

Table 6 describes how to set the input divider using the DIVIDE pin. If the /8 setting is desired, then this feature is accessed through the host configuration method only; refer to [Device Control Using the Host Interface](#).

**Table 6. CDCUN1208LP Pin Control of INDIV Divider**

DIVIDE (Pin 1)	INDIV DIVIDER SETTING
LOW	/2
HIGH	/4
OPEN	/1

### 8.3.3 Smart Input Multiplexer (INMUX)

The smart multiplexer supports manual and automatic switching between IN1 and IN2. If enabled, the smart multiplexer switches automatically between clock inputs based on a prioritization scheme shown in Table 7. If using the smart multiplexer auto mode, the frequencies of the clocks applied to the smart multiplexer through IN1 and IN2 (through the divider) may differ by up to 20%. The phase relationship between clock inputs has no restrictions. The smart multiplexer includes signal conditioning that provides glitch suppression.<sup>(1)</sup>

Upon the detection of a loss of signal on the input with higher priority, the smart multiplexer switches over to the other clock input on the first incoming rising edge. During this switching operation, the output of the smart multiplexer is low. Upon restoration of the higher priority clock, the smart multiplexer waits until it detects four complete cycles from the higher priority clock prior to switching the output of the smart multiplexer back to the higher priority clock. During this switching operation, the output of the smart multiplexer remains high until the next falling edge as shown in Figure 29.

**8.3.3.1 Pin Configuration of the Smart Input Multiplexer (INMUX)**

Table 7 shows how to control the smart input multiplexer. In pin configuration mode, the INSEL pin is sampled continuously, so that the application may select the input clock at any time.

**Table 7. Control of INMUX via the INSEL Pin**

INSEL(Pin 2)	IN1 BUFFER SETTING	IN2 BUFFER SETTING
LOW	ON and selected by INSEL multiplexer	OFF
HIGH	OFF	ON and selected by INSEL mux
OPEN	Smart multiplexer selects input. IN1 is the primary input (it has the highest priority, therefore if it is available, the smart multiplexer selects IN1)	

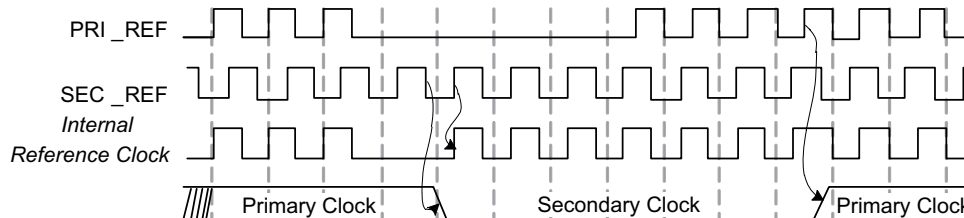

**Figure 29. CDCUN1208LP Smart Multiplexer Operation**

- (1) This implementation does not implement a phase build-out mechanism; rather, analog filtering insuring a smooth transition at device outputs.

## 8.4 Device Functional Modes

### 8.4.1 Device Control Using the Host Interface

Host configuration mode affords a greater degree of flexibility. Unlike pin configuration mode, in which the pin settings affect the entire device, host configuration mode enables the user to apply different settings to each input and output port, as depicted in Figure 30. This includes the ability to mix and match output type, edge rate control, and output enable settings. The host interface is enabled or selected by strapping the MODE pin either high (for I<sup>2</sup>C) or low (for SPI) and resetting the device. Additional device features are accessible only through the host interface as well. For instance, the user can configure the input divider (IDIV) to /8 in host configuration mode only. Additionally, the system can power down the device through device registers.

#### 8.4.1.1 OE and INSEL in Host Configuration Mode

In host configuration mode, the OE pin is no longer available; thus buffers are controlled individually through the host interface. The input multiplexer can be controlled either through the pin or through the device registers, in accordance with Table 12.

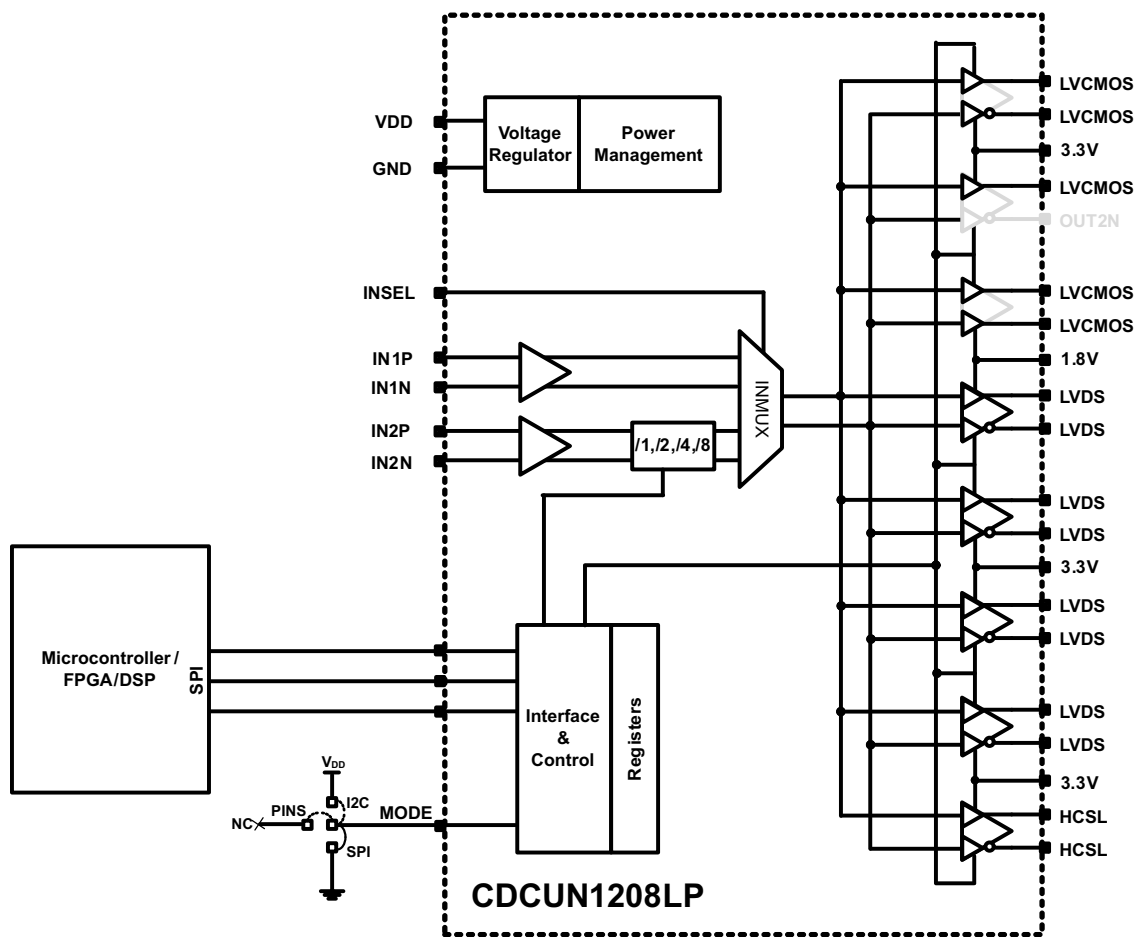

Copyright © 2017, Texas Instruments Incorporated

Figure 30. CDCUN1208LP Host Configuration – Typical Application

Device Functional Modes (continued)

When the host interface is enabled, certain pins take on alternative functions, according to Table 8.

Table 8. CDCUN1208LP Host Configuration Pins

PIN NAME IN HOST MODE	ALT PIN NAME IN PIN MODE (MODE = OPEN)	PIN NUMBER	PIN NAME IN HOST PROGRAMMING MODE (MODE/Pin 30 is tied high or low)	PIN NAME IN PIN CONFIGURATION MODE (only if MODE/Pin 30 is OPEN)
MODE		30	Programming mode 1 = I <sup>2</sup> C, 0 = SPI, OPEN = Pins (alternative description applies)	
SDA/MOSI	DIVIDE	1	Host interface data (I <sup>2</sup> C) / SPI Master output slave input (data In)	Input divider pin control
MISO	OTTP	19	SPI master input slave output (data out)	Output type (OTTP) pin control
SCL	OE	32	Host interface clock	Device output enable 1 = Enable, 0 = Disable
ADDR/CS	ERC	31	Host interface address (I <sup>2</sup> C) / chip select (SPI) Pull ADDR to GND for I2C communication	Output edge rate control 1 = Fast, 0 = Slow, OPEN = Medium

The CDCUN1208LP samples the MODE pin after the device exits the power-on reset (POR) state. The device is placed in the RESET state in one of two ways: a POR circuit automatically resets the device after power is applied; or through the RESET bit (R15[1]) in register memory (see Table 12). This RESET bit is only accessible in host configuration mode. If the MODE pin (pin 11) is open (no connection), then the device is placed in the pin configuration mode and all settings are determined by the state of various pins according to Table 1 and Figure 28. If the MODE pin is low, then device enables the SPI interface; and, if MODE is high, then I<sup>2</sup>C is enabled.

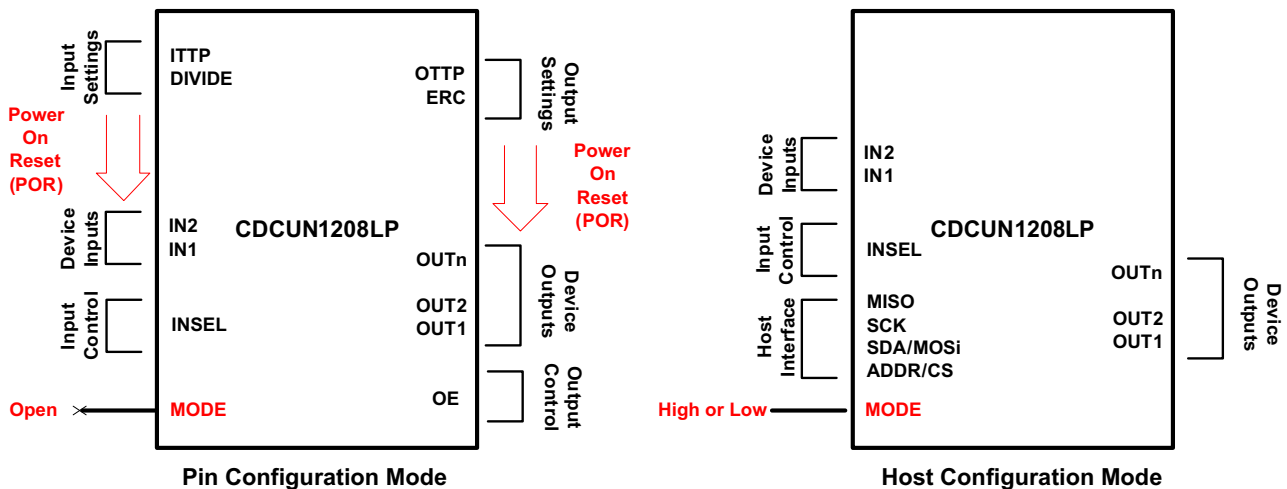

Copyright © 2017, Texas Instruments Incorporated

Figure 31. CDCUN1208LP Pin and Host Configuration Mode

## 8.5 Programming

### 8.5.1 Host Interface Hardware Information

#### 8.5.1.1 SPI Communication

A SPI communication link includes a master and one or more slaves (note that CDCUN1208LP supports only single-device). Table 8 lists the four signal lines that form a SPI communication link. Figure 32 shows the format for SPI messages. The SPI master (host) initiates communication by asserting SCS low. Information on SDI/SDO is latched on each rising edge of SCL. The first bit transmitted on SDI establishes the direction of the SPI transfer. Next, the master transmits the address to be written/read (up to 15 bits). If the operation is a write, the master transmits 16 data bits on SDI. If the transfer is a read, the slave transmits 16 data bits on SDO (the master continues to clock the transfer through SCL). Figure 34 and Table 9 show the timing specifications for SPI.

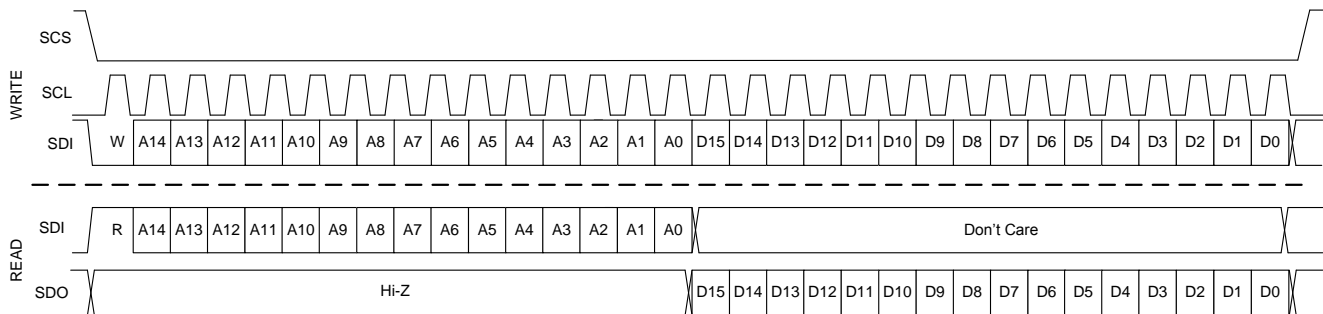

Figure 32. SPI Message Format

##### 8.5.1.1.1 CDCUN1208LP SPI Addressing

Figure 33 shows how to construct the address field for SPI messages to and from the CDCUN1208LP. The device is assigned a 4-bit fixed address (0001b). For the host to communicate with the CDCUN1208LP, the address must include this fixed value in the correct position for the device to recognize the message.

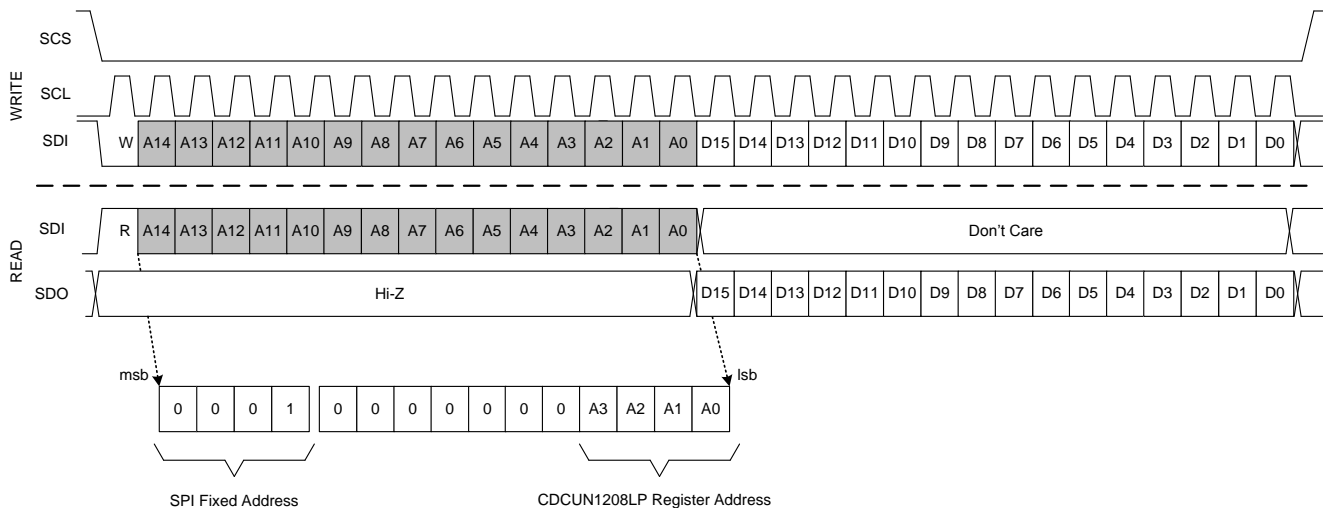

Figure 33. CDCUN1208LP Device Addressing - SPI Mode

##### 8.5.1.1.2 Writing to the CDCUN1208LP

To initiate a SPI data transfer, the master (host) asserts the SCS (serial chip select) pin low (see Figure 32). The first rising edge of the clock signal (SCL) transfers the bit presented on the SDI pin of the CDCUN1208LP. This bit signals if a read (first bit high) or a write (first bit low) will transpire. The master shifts data to the slave with each rising edge of SCL. Following the W/R bit are 4 fixed bits followed by 11 bits that specify the address of the target register in the register file (see Figure 33). The 16 bits that follow are the data payload. If the master sends

## Programming (continued)

an incomplete message, (that is, the master de-asserts the SCS pin high prior to a complete message transmission), then the slave aborts the transfer, and device makes no changes to the register file or the hardware. The master signals the slave of the completed transfer and disables the SPI port by de-asserting the SCS pin high. At no time should the clock be toggled while SCS is high. CDCUN1208LP should always be used in single-slave SPI configuration.

### 8.5.1.1.3 Reading From the CDCUN1208LP

As with the write operation, the master first initiates a SPI transfer by asserting the SCS pin low. The host signals a read operation by shifting a logical high in the first bit position, signaling the slave that the master is initiating a read data transfer from the slave. Thereafter, the master specifies the address of interest according to Figure 33. During the 16 clock cycles that follow, the slave presents the data from the register specified in the first half of the message on the SDO pin. The master signals the slave that the transfer is complete by de-asserting the SCS pin high. At no time should the clock be toggled while SCS is high. CDCUN1208LP should always be used in single-slave SPI configuration.

### 8.5.1.1.4 Block Write/Read Operation

The CDCUN1208LP supports a block write and block read operation. The master need only specify the lowest address of the sequence of addresses that the host needs to access. The CDCUN1208LP automatically increments the internal register address pointer if the SCS pin remains active low after the SPI port finishes the initial 32-bit transmission sequence. Each transmission of 16 bits (a data payload width) results in the slave automatically incrementing the address pointer (provided the SCS pin remains active low for all sequences).

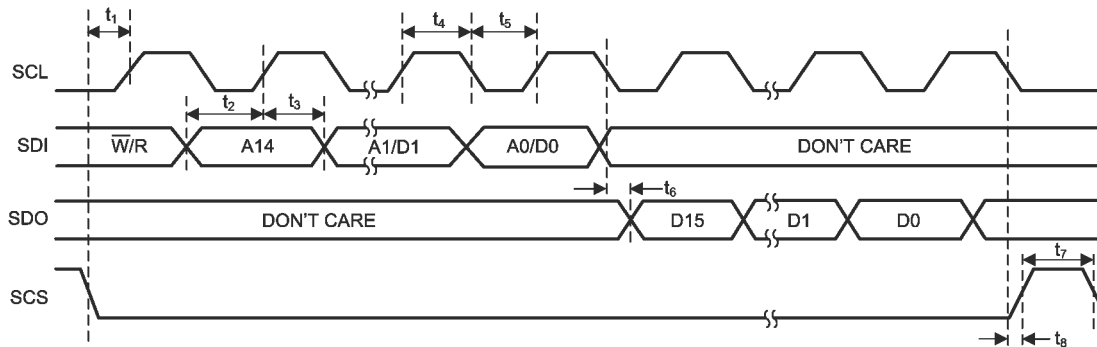

Figure 34. SPI Timing Diagram

**Programming (continued)**
**Table 9. SPI Timing Specifications**

PARAMETER		MIN	TYP	MAX	UNIT
$f_{\text{Clock}}$	Clock frequency for the SCL			20	MHz
$t_1$	SCS to SCL setup time	10			ns
$t_2$	SDI to SCL setup time	10			ns
$t_3$	SDI to SCL hold time	10			ns
$t_4$	SCL high duration	25			ns
$t_5$	SCL low duration	25			ns
$t_6$	SCL to SDO Setup time	10			ns
$t_7$	SCS pulse width	20			ns
$t_8$	SCL falling edge to SCS release time	10			ns

**8.5.1.2 I<sup>2</sup>C Communication**

The CDCUN1208LP incorporates an I<sup>2</sup>C port compliant with I<sup>2</sup>C Bus Specification V2.1 (7-bit addressing). Some highlights are contained herein to provide clarity with respect to how communication between the host and the CDCUN1208LP is facilitated. The I<sup>2</sup>C bus comprises two signals (clock – SCL, and data – SDA). I<sup>2</sup>C implements a master-slave protocol and supports multi-master implementations. Unlike SPI that implements a chip select signal for device-level addressing and separate data signals for transmit and receive, I<sup>2</sup>C embeds the device address in the serial data stream. Because of this, devices that reside on the I<sup>2</sup>C must have a unique bus address. I<sup>2</sup>C also uses the protocol to control the direction of data flow through the data signaling line.



### 8.5.1.2.1 Message Transmission

#### 8.5.1.2.1.1 Data and Address Bits

When transmitting address or data bits, the transmitter must only change the state of SDA when SCL is low. During the time that SCL is high, SDA must be stable (no transitions).

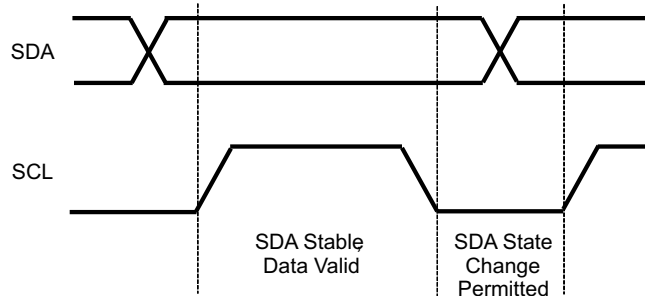

Figure 35. I<sup>2</sup>C Data/Address Bit Transmission

#### 8.5.1.2.1.2 Special Symbols – Start (S) and Stop (P)

Messages are framed by the master by generating a START and a STOP symbol. The START symbol is signaled by transitioning the SDA line from high to low while the SCL line is high. The STOP symbol is signaled by transitioning the SDA line from low to high while the SCL line is high.

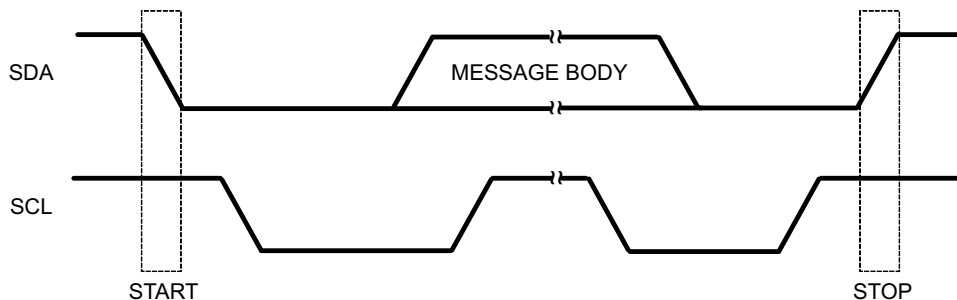

Figure 36. I<sup>2</sup>C Bus START and STOP Symbol Generation

#### 8.5.1.2.1.3 Special Symbols – Acknowledge (ACK)

The acknowledge symbol must be sent by the receiver during the 9<sup>th</sup> clock cycle after the transmitter sends a byte of data. The transmitter allows the SDA pin to go high, and the receiver pulls the line low to acknowledge the receipt of the byte (leaving the SDA high indicates that the byte was not received). If this occurs the transmitter issues a STOP and retransmits the message. If the receiver is not prepared to receive another byte, it can suspend transmission by holding the SDA line low during the ACK time slot. When the receiver is ready to receive another byte, it releases the SDA line.

**8.5.1.2.1.4 Generic Message Frame**

Figure 37 shows a typical format for I<sup>2</sup>C messages. The message frame is bracketed by the START and STOP symbols (both generated by the master). If a START symbol has not been transmitted, then the bus is considered 'available'. If a START symbol has been transmitted and a STOP symbol has not been transmitted, the bus is considered 'busy'. The first 8 bits transmitted include the R/W bit and a 7-bit I<sup>2</sup>C address field. The reception of each byte grouping that is transmitted must be acknowledged by the receiver. Next, the high byte of the data payload is transmitted (MSB first) followed by an acknowledgment by the receiver. Finally, the low byte is sent. After acknowledgment, the master sends a STOP symbol to end the message frame.

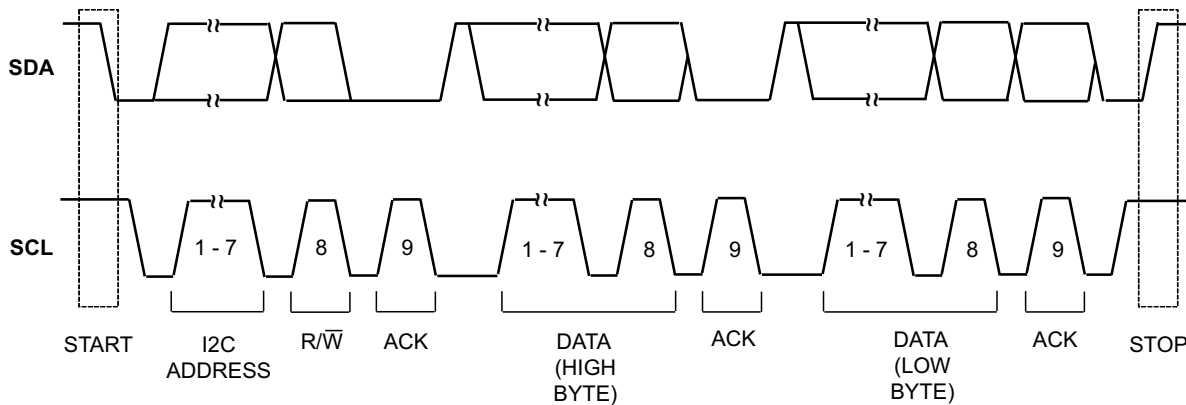

**Figure 37. I<sup>2</sup>C Message Format**
**8.5.1.2.1.5 CDCUN1208LP Message Format**

Figure 38 shows the format of addressing and flow control for I<sup>2</sup>C messages to and from the CDCUN1208LP. A message includes two address fields. The I<sup>2</sup>C address is used to support multiple devices on the bus (each device must have a unique I<sup>2</sup>C address). The register address specifies which register of the device identified by the I<sup>2</sup>C address is to be written/read.

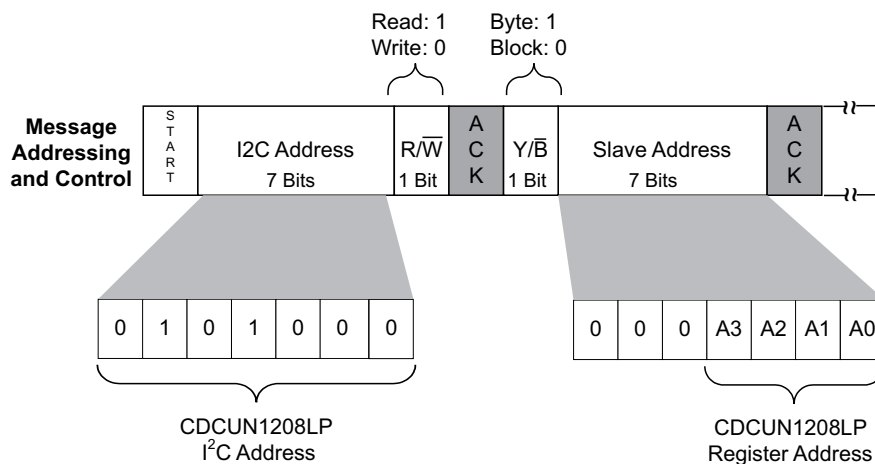

**Figure 38. CDCUN1208LP I<sup>2</sup>C Message - Addressing**
**8.5.1.2.1.6 CDCUN1208LP Device Addressing (I<sup>2</sup>C Address)**

Figure 38 outlines the construction of the I<sup>2</sup>C address shown in Figure 37. The I<sup>2</sup>C address is set to 7b'0101000, or 0x28. The ADDR pin must be pulled to ground. The next 8 bits transmitted is called the register address.

8.5.1.2.1.7 CDCUN1208LP Device Addressing (Register Address)

Figure 38 shows the format of the register address field of the I<sup>2</sup>C message. The first bit determines if the transfer is a byte or a block (more than one byte). The CDCUN1208LP register width is 16 bits (2 bytes), therefore, generally block addressing is used to access each register in its entirety. Because the I<sup>2</sup>C protocol requires that the slave address is a 7-bit field, the leading 3-bits are all '0' while the trailing 4-bits specify the device register of interest.

8.5.1.2.2 I<sup>2</sup>C Master and Slave Handshaking

Figure 39 shows the handshaking between the master (host) and the slave (CDCUN1208LP) that the I<sup>2</sup>C protocol supports. In all cases, the master drives the SCL (clock line); however, depending on the direction of transfer/acknowledgment, the master or the slave device drives SDA (data line).

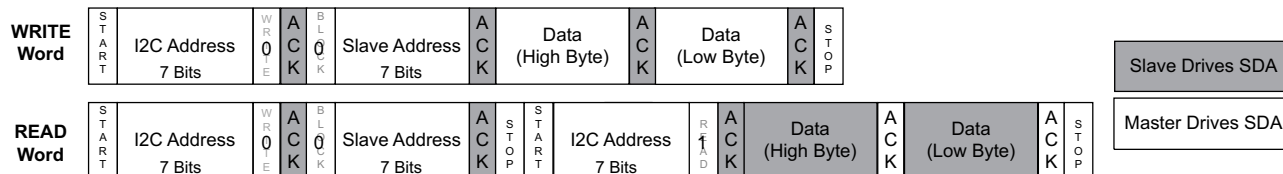

Figure 39. I<sup>2</sup>C Master and Slave Handshaking Example

8.5.1.2.3 Block Read/Write

For block write/read operations, the bytes are accessed in sequential order from lowest to highest byte (with most significant bit first), with the ability to stop after any complete byte has been transferred. The start address of the transfer is specified in the same way a single word transfer is initiated.

**8.5.1.2.4 I<sup>2</sup>C Timing**

Figure 40 and Table 10 provide details regarding the timing requirements for I<sup>2</sup>C:

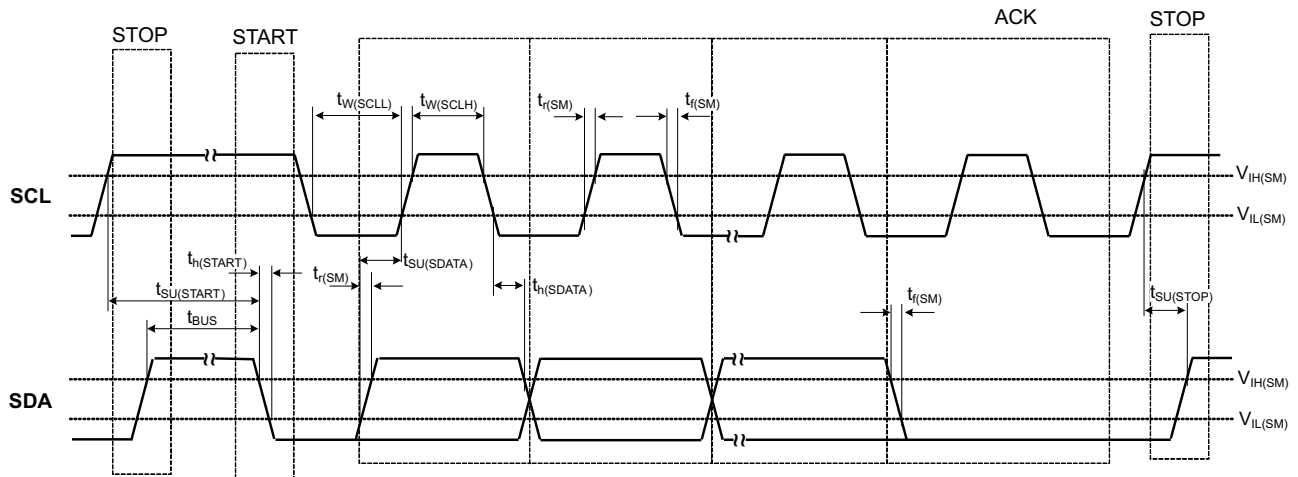

**Figure 40. I<sup>2</sup>C Timing Diagram**

**Table 10. I<sup>2</sup>C Timing Requirements**

PARAMETER		MIN	MAX	UNIT
$f_{SCL}$	SCL clock frequency	0	100	kHz
$t_{su}(START)$	START setup time (SCL high before SDA low)	4.7		$\mu s$
$t_h(START)$	START hold time (SCL low after SDA low)	4		$\mu s$
$t_w(SCLL)$	SCL low-pulse duration	4.7		$\mu s$
$t_w(SCLH)$	SCL high-pulse duration	4		$\mu s$
$t_h(SDA)$	SDA hold time (SDA valid after SCL low)	0	3.45	$\mu s$
$t_{su}(SDA)$	SDA setup time	250		ns
$t_r$	SCL / SDA input rise time		1000	ns
$t_f$	SCL / SDA input fall time		300	ns
$t_{su}(STOP)$	STOP setup time	4		$\mu s$
$t_{BUS}$	Bus free time between a STOP and START condition	4.7		$\mu s$

## 8.6 Register Maps

### 8.6.1 Device Registers

#### 8.6.1.1 Device Registers: Register 00-07

Register 00: OUT1

Register 01: OUT2

Register 02: OUT3

Register 03: OUT4

Register 04: OUT5

Register 05: OUT6

Register 06: OUT7

Register 07: OUT8

**Table 11. CDCUN1208LP Register 0–7 Bit Definitions**

RAM BIT	BIT NAME	RELATED BLOCK	DESCRIPTION / FUNCTION	POWER UP CONDITION	
15	TI RESERVED		<b>TI RESERVED</b>		
14					
13					
12					
11					
10	OUTx_CMOS_MODE	Reg 00: OUT1 Reg 01: OUT2 Reg 02: OUT3 Reg 03: OUT4 Reg 04: OUT5 Reg 05: OUT6 Reg 06: OUT7 Reg 07: OUT8	<b>OUTx CMOS MODE</b> 1 – Both sides pseudo differential 0 – Both sides in phase	0	
9	OUTx_ERC[2:0]		<b>OUTx Edge Rate Control</b> 111 – Medium 100 – Fast 000 – Slow	0	
8				0	
7				0	
6	TI RESERVED		<b>TI RESERVED</b>		0
5					0
4	OUTx_OE[1:0]		Reg 00: OUT1 Reg 01: OUT2 Reg 02: OUT3 Reg 03: OUT4 Reg 04: OUT5 Reg 05: OUT6 Reg 06: OUT7 Reg 07: OUT8	<b>OUTx Output Enable</b> OTTP = LVCMOS 11 – OUT1P: ON   OUT1N: ON 10 – OUT1P: ON   OUT1N: OFF 01 – OUT1P: OFF   OUT1N: ON 00 – OUT1P: OFF   OUT1N: OFF	0
3				OTTP = Differential (LVDS, HCSSL) 00 – OFF 11 – ON	0
2	OUTx_OTTP[1:0]		Reg 00: OUT1 Reg 01: OUT2 Reg 02: OUT3 Reg 03: OUT4 Reg 04: OUT5 Reg 05: OUT6 Reg 06: OUT7 Reg 07: OUT8	<b>OUTx Output Type</b> 11 – HCSSL 10 – Reserved 01 – LVCMOS 00 – LVDS	0
1					0
0	OUTx_PD	Reg 00: OUT1 Reg 01: OUT2 Reg 02: OUT3 Reg 03: OUT4 Reg 04: OUT5 Reg 05: OUT6 Reg 06: OUT7 Reg 07: OUT8	<b>OUTx Buffer</b> 1 – Disabled in Tri-State 0 – Enabled	0	

**Table 12. CDCUN1208LP Registers 11–15 Bit Definitions**

REGISTER ADDRESS	RAM BIT	BIT NAME	RELATED BLOCK	DESCRIPTION / FUNCTION	POWER UP CONDITION	
11	15	TI RESERVED				
	14	TI RESERVED				
	13	TI RESERVED				
	12	TI RESERVED				
	11	TI RESERVED				
	10	TI RESERVED				
	9	TI RESERVED				
	8	TI RESERVED			0	
	7	TI RESERVED			0	
	6	TI RESERVED			0	
	5	IN_DIV[1]	Input (IN2 – Divider)		<b>Input Divider Control</b> 1 1 = /8 1 0 = /4 0 1 = /2 0 0 = /1	0
	4	IN_DIV[0]				0
	3	IN_TYPE[1]	Input <sup>(1)</sup> (IN1 and IN2 Type)		<b>Input Type</b> 1 1 = HCSSL 1 0 = LVCMOS 0 1 = LVCMOS 0 0 = LVDS	0
2	IN_TYPE[0]	0				
1	INSEL[1]	Input (multiplexer)		<b>Input Multiplexer Control</b> 1 1 = Control through INSEL pin 1 0 = Smart MUX enabled, IN 1=primary 0 1 = IN2 buffer selected 0 0 = IN1 buffer selected	0	
0	INSEL[0]				0	
12-14	ALL	TI RESERVED				
15	2-15	TI RESERVED				
	1	RESET		<b>Device Reset</b> 1 = Reset device 0 = Run device	0	
	0	PD		<b>Device Power Down</b> 1 = Device is powered down 0 = Device is active	0	

(1) When configuring device inputs as LVCMOS, apply the single-ended clock signal to INxP and leave INxN either floating or ground it. The power supply voltage (1.8 V, 2.5 V, or 3.3 V) applied to V<sub>DD</sub> (pin 5) establishes the switching thresholds for IN1 and IN2 in LVCMOS mode.

## 9 Application and Implementation

### NOTE

Information in the following applications sections is not part of the TI component specification, and TI does not warrant its accuracy or completeness. TI's customers are responsible for determining suitability of components for their purposes. Customers should validate and test their design implementation to confirm system functionality.

### 9.1 Application Information

The CDCUN1208LP is a low additive jitter, 2:8 fan-out buffer with universal inputs and outputs. The low-power consumption, low output skew, and low additive jitter make for a flexible device in demanding applications.

### 9.2 Typical Application

#### 9.2.1 PCI Express Applications

Texas Instruments offers a complete clock solution for PCI Express applications. The CDCUN1208LP can be used to fan out the 100-MHz clock signal provided by the CDCM9102 as depicted in [Figure 41](#).

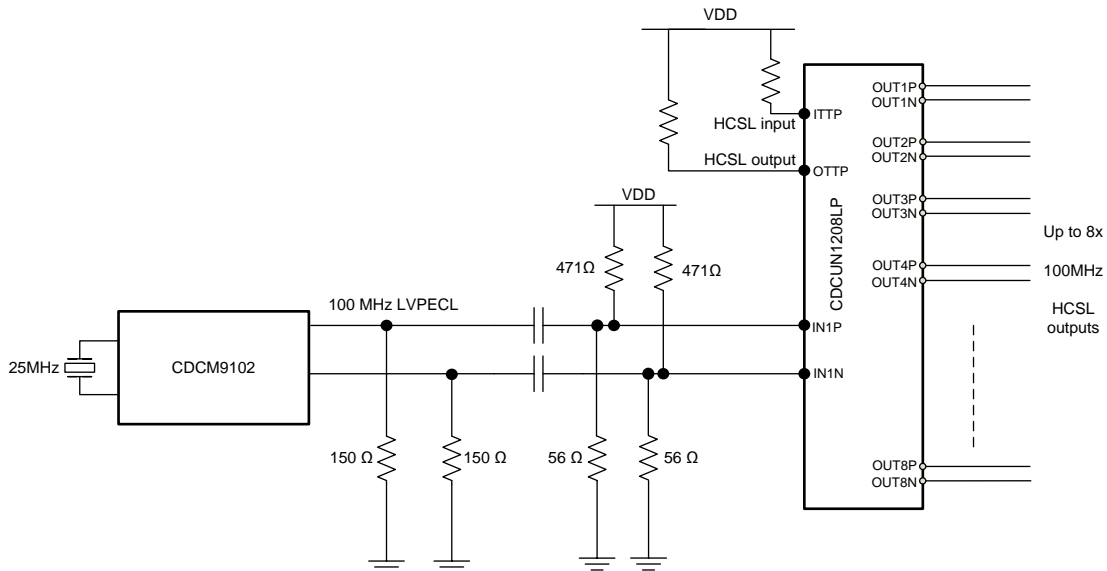

Copyright © 2017, Texas Instruments Incorporated

Figure 41. Clock Solution for PCIe Express Applications

#### 9.2.1.1 Design Requirements

For this design example, use the parameters shown in [Table 13](#).

Table 13. Design Parameters

PARAMETER	VALUE
$f_{IN1,2}$	Input single ended frequency of at least 800 kHz and at most 250 MHz.
$f_{INDIFF}$	Input differential frequency of at least 800 kHz and at most 400 MHz (here 100 MHz).
$\Delta V/\Delta T$ Input edge rate	Input slew rate of at least 0.75 V/ns.

### 9.2.1.2 Detailed Design Procedure

The CDCUN1208LP is a easy-to-use device. The user determines the following parameters in order:

In control mode:

- Pin control mode or SPI mode (host interface) : this is done by externally pulling up or pulling down the MODE pin.

In pin control mode:

- The input type, optional input divider ratio and input multiplexer selection should be set.
- The output type, optional output edge rate control, and output enable should be set. This is described in detail in [Device Control Using Configuration Pins](#).

In host control mode:

- SPI interface should be connected to the host (only one CDCUN1208LP device can be connected to the bus).
- Communication should follow the procedure described in [Device Control Using the Host Interface](#).

### 9.2.1.3 Application Curves

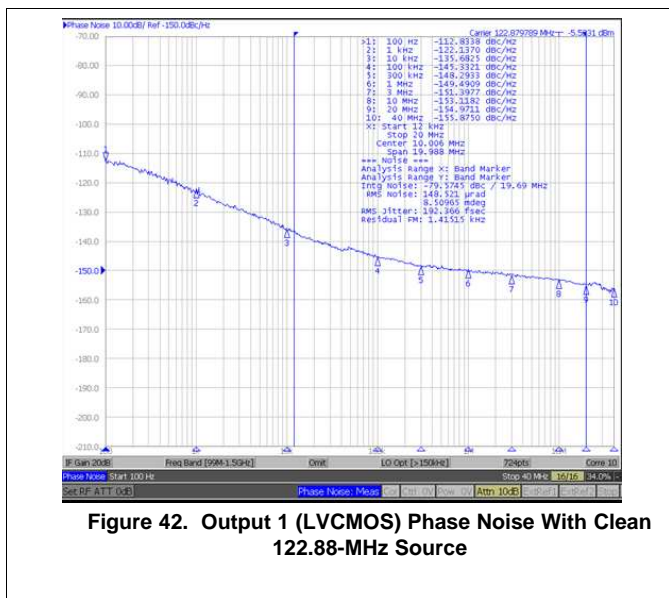

Figure 42. Output 1 (LVCMOS) Phase Noise With Clean 122.88-MHz Source

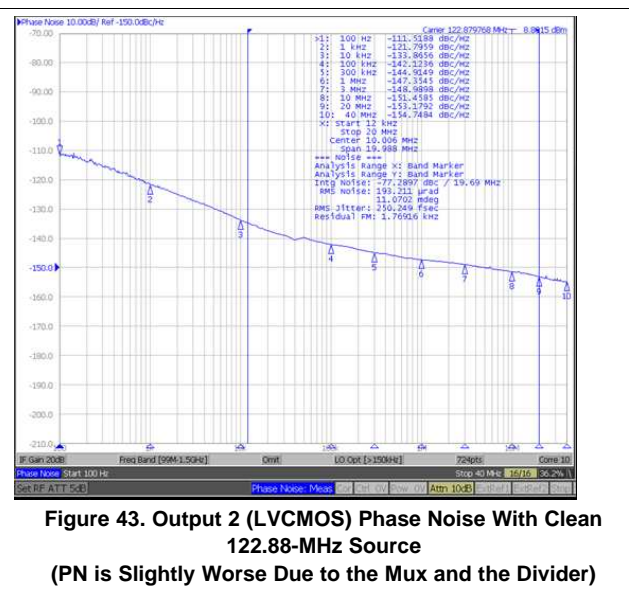
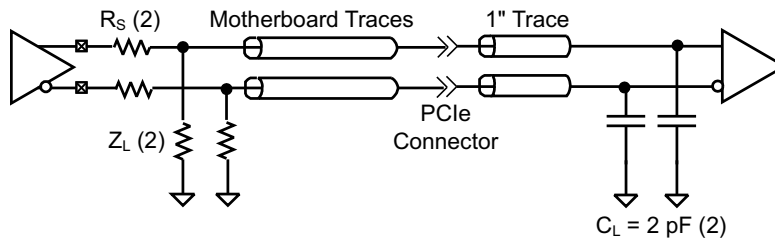

Figure 43. Output 2 (LVCMOS) Phase Noise With Clean 122.88-MHz Source (PN is Slightly Worse Due to the Mux and the Divider)



### 9.3 Systems Examples

Figure 44 shows a typical application in which the receiver is off-board. The PCIe Specification (CEM2.0) requires that all source termination is on the motherboard (not on the daughter card). For this reason, the termination resistors are placed as shown. Additionally, source resistors are employed to eliminate ringing. In this case,  $Z_L$  can vary between  $40\ \Omega$  and  $60\ \Omega$  and  $R_S$  can range from  $22\ \Omega$  to  $33\ \Omega$ .



Copyright © 2017, Texas Instruments Incorporated

Figure 44. Typical Configuration – Off-Board Receiver

Figure 45 shows a typical application in which the receiver is on-board. In this case, series resistors are not required to eliminate ringing as proper termination is achieved. In this case, two termination resistors,  $Z_L = 49.9\ \Omega$ , are placed close to the receiver.

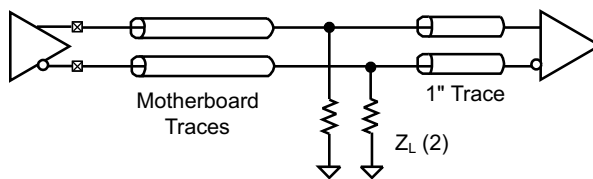

Copyright © 2017, Texas Instruments Incorporated

Figure 45. Typical Configuration – On-Board Connection

## 10 Power Supply Recommendations

### 10.1 CDCUN1208LP Power Consumption

**Table 14. CDCUN1208LP Power Consumption (T<sub>A</sub> = –40°C to 85°C)**

PARAMETER	DEVICE SETTINGS (See Table 1) <sup>(1)</sup>							TEST CONFIGURATION	DESCRIPTION	MAX CURRENT V <sub>DD</sub> = 1.8V f <sub>OUT</sub> = f <sub>in</sub> = 100 MHz	MAX CURRENT V <sub>DD</sub> = 3.3V f <sub>OUT</sub> = f <sub>in</sub> = 100MHz	UNIT
	MODE	OE	ERC	OTTP	INSEL	ITTP	PD Bit					
I <sub>PD1.8,3.3</sub>	L or H	L	X	X	X	L	H	Host configuration mode (see Host Configuration Mode)	Device power down	3	4	mA
I <sub>CORE1.8,3.3</sub>	O	L	X	X	X	L	X	Figure 25a,b,c	Device outputs off	26	35	mA
I <sub>HCSL1.8,3.3</sub>	O	H	O	H	L	O	X	Figure 25a	HCSL buffer current consumption <sup>(2)</sup>	23	23	mA
I <sub>LVDS1.8,3.3</sub>	O	H	O	L	L	O	X	Figure 25b	LVDS buffer current consumption <sup>(2)</sup>	9	9	mA
I <sub>LVC MOS1.8,3.3</sub>	O	H	O	O	L	O	X	Figure 25c	LVC MOS buffer current consumption (one side) <sup>(2)</sup>	8	11	mA
I <sub>DEV-HCSL1.8,3.3</sub>	O	H	O	H	L	O	X	Figure 25a	Device current consumption – HCSL mode	200	200	mA
I <sub>DEV-LVDS1.8,3.3</sub>	O	H	O	L	L	O	X	Figure 25b	Device current consumption – LVDS mode	80	90	mA
I <sub>DEV-LVC MOS1.8,3.3</sub>	O	H	O	O	L	O	X	Figure 25c	Device current consumption – LVC MOS mode	130	210	mA

(1) H = input high, L = input low; O = input open

(2) Buffer current consumption values represent the average of the current drawn by V<sub>DDO1</sub>, V<sub>DDO2</sub>, V<sub>DDO3</sub>, and V<sub>DDO4</sub>, divided by 8 (differential mode) or 16 (single-ended mode).

### 10.2 Device Power Supply Connections and Sequencing

VDD (pin 5) is the core power supply of the device while VDDOx (pins 11, 14, 22, and 27) provide power for the output sections. The core supply must be present either before the application of the output power supplies or be present simultaneously. Applying an output power supply voltage on any of the VDDOx pins prior to the application of power to the core supply pin potentially results in improper device operation.

VDDO2 (pin 14) and VDDO4 (pin 27) provide power for OUT1/OUT2 and OUT7/OUT8, respectively. Additionally, these pins provide power to integrated voltage regulators that condition power for two banks of outputs. For example, the regulator associated with OUT1–OUT4 receives power from the VDDO2 pin. Consequently, if the application requires one or two outputs from a bank of four, then the application must use OUT3/OUT4 and apply power through VDDO2 <sup>(1)</sup>. Likewise, the regulator that conditions power for OUT5–OUT8 receives power from VDDO4 (pin 27). If the application uses subset of OUT5–OUT8, then OUT7/OUT8 must be used. For example, if the application uses 6 of the 8 output channels, then VDDO1, VDDO2, and VDDO4 (along with OUT1–OUT4, and OUT7–OUT8) must be used. If the application requires the use of 7 of the 8 output channels, the VDDO1–VDDO4 are used, and OUT1–OUT7 or OUT1–OUT6 and OUT8 could be used.

(1) If OUT1 or OUT2 are used and VDDO1 is powered but not VDDO2, the CDCUN1208LP will not function properly. Likewise, if OUT5 or OUT6 are used and VDDO3 is powered but not VDDO4, then the device will not function properly either.

### 10.3 Device Inputs (IN1, IN2)

Figure 46 shows how to interface certain common signaling formats to the device inputs of the CDCUN1208LP. This entails both proper signal termination as well as input buffer configuration through the input type (ITTP) pin.

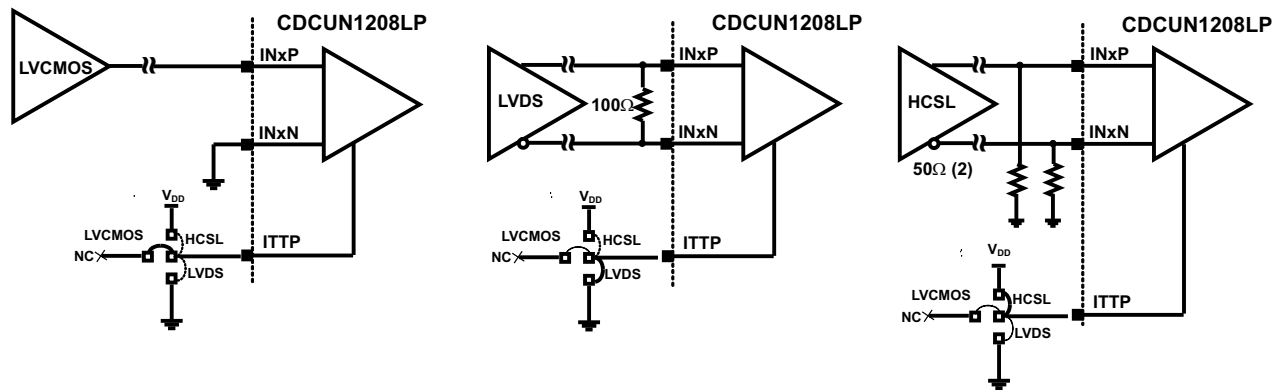

Copyright © 2017, Texas Instruments Incorporated

Figure 46. Common Interfaces to Device Inputs – DC Coupling

## 11 Layout

### 11.1 Layout Guidelines

- Keep the connections between the bypass capacitors and the power supply on the device as short as possible.
- Ground the other side of the capacitor using a low impedance connection to the ground plane.
- If the capacitors are mounted on the back side, 0402 components can be employed.
- For component side mounting, use 0201 body size capacitors to facilitate signal routing.
- Use a matrix of ground vias to connect the thermal pad to the ground layer.

### 11.2 Layout Example

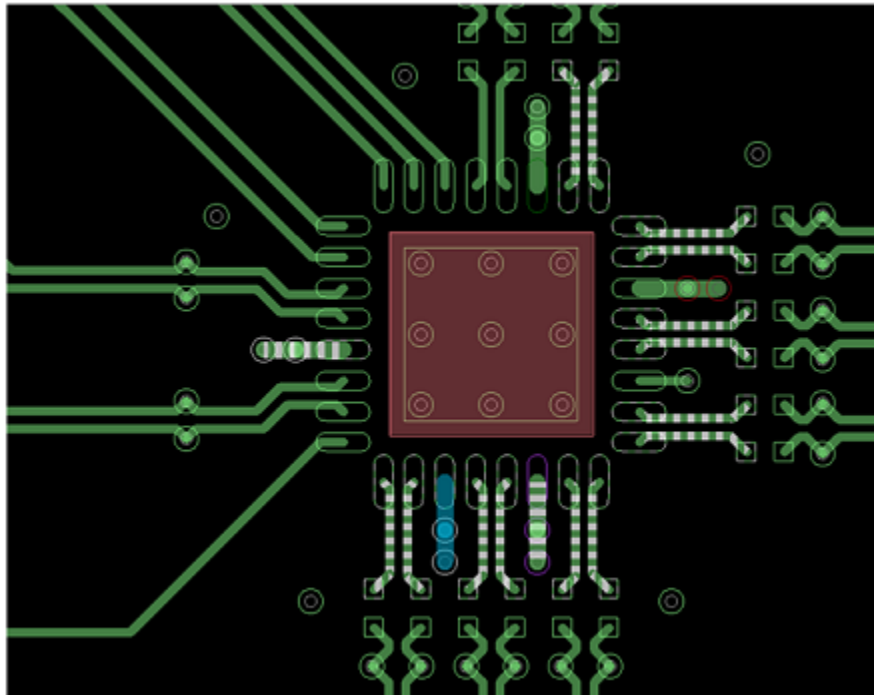

**Figure 47. Example Layout**

## 12 器件和文档支持

### 12.1 接收文档更新通知

要接收文档更新通知，请导航至 [TI.com.cn](http://TI.com.cn) 上的器件产品文件夹。单击右上角的 [通知我](#) 进行注册，即可每周接收产品信息更改摘要。有关更改的详细信息，请查看任何已修订文档中包含的修订历史记录。

### 12.2 社区资源

下列链接提供到 TI 社区资源的连接。链接的内容由各个分销商“按照原样”提供。这些内容并不构成 TI 技术规范，并且不一定反映 TI 的观点；请参阅 TI 的 [《使用条款》](#)。

**TI E2E™ Online Community** *TI's Engineer-to-Engineer (E2E) Community*. Created to foster collaboration among engineers. At [e2e.ti.com](http://e2e.ti.com), you can ask questions, share knowledge, explore ideas and help solve problems with fellow engineers.

**Design Support** *TI's Design Support* Quickly find helpful E2E forums along with design support tools and contact information for technical support.

### 12.3 商标

E2E is a trademark of Texas Instruments.  
All other trademarks are the property of their respective owners.

### 12.4 静电放电警告



这些装置包含有限的内置 ESD 保护。存储或装卸时，应将导线一起截短或将装置放置于导电泡棉中，以防止 MOS 门极遭受静电损伤。

### 12.5 术语表

**SLYZ022** — *TI 术语表*。

这份术语表列出并解释术语、缩写和定义。

## 13 机械、封装和可订购信息

以下页面包含机械、封装和可订购信息。这些信息是指定器件的最新可用数据。数据如有变更，恕不另行通知，且不会对此文档进行修订。如需获取此数据表的浏览器版本，请查阅左侧的导航栏。

**PACKAGING INFORMATION**

Orderable part number	Status (1)	Material type (2)	Package   Pins	Package qty   Carrier	RoHS (3)	Lead finish/ Ball material (4)	MSL rating/ Peak reflow (5)	Op temp (°C)	Part marking (6)
<a href="#">CDCUN1208LPRHBR</a>	Active	Production	VQFN (RHB)   32	3000   LARGE T&R	Yes	NIPDAU	Level-1-260C-UNLIM	-40 to 85	UN 1208LP
<a href="#">CDCUN1208LPRHBT</a>	Active	Production	VQFN (RHB)   32	250   SMALL T&R	Yes	NIPDAU	Level-1-260C-UNLIM	-40 to 85	UN 1208LP

(1) **Status:** For more details on status, see our [product life cycle](#).

(2) **Material type:** When designated, preproduction parts are prototypes/experimental devices, and are not yet approved or released for full production. Testing and final process, including without limitation quality assurance, reliability performance testing, and/or process qualification, may not yet be complete, and this item is subject to further changes or possible discontinuation. If available for ordering, purchases will be subject to an additional waiver at checkout, and are intended for early internal evaluation purposes only. These items are sold without warranties of any kind.

(3) **RoHS values:** Yes, No, RoHS Exempt. See the [TI RoHS Statement](#) for additional information and value definition.

(4) **Lead finish/Ball material:** Parts may have multiple material finish options. Finish options are separated by a vertical ruled line. Lead finish/Ball material values may wrap to two lines if the finish value exceeds the maximum column width.

(5) **MSL rating/Peak reflow:** The moisture sensitivity level ratings and peak solder (reflow) temperatures. In the event that a part has multiple moisture sensitivity ratings, only the lowest level per JEDEC standards is shown. Refer to the shipping label for the actual reflow temperature that will be used to mount the part to the printed circuit board.

(6) **Part marking:** There may be an additional marking, which relates to the logo, the lot trace code information, or the environmental category of the part.

Multiple part markings will be inside parentheses. Only one part marking contained in parentheses and separated by a "-" will appear on a part. If a line is indented then it is a continuation of the previous line and the two combined represent the entire part marking for that device.

**Important Information and Disclaimer:**The information provided on this page represents TI's knowledge and belief as of the date that it is provided. TI bases its knowledge and belief on information provided by third parties, and makes no representation or warranty as to the accuracy of such information. Efforts are underway to better integrate information from third parties. TI has taken and continues to take reasonable steps to provide representative and accurate information but may not have conducted destructive testing or chemical analysis on incoming materials and chemicals. TI and TI suppliers consider certain information to be proprietary, and thus CAS numbers and other limited information may not be available for release.

In no event shall TI's liability arising out of such information exceed the total purchase price of the TI part(s) at issue in this document sold by TI to Customer on an annual basis.

**TAPE AND REEL INFORMATION**

**QUADRANT ASSIGNMENTS FOR PIN 1 ORIENTATION IN TAPE**

\*All dimensions are nominal

Device	Package Type	Package Drawing	Pins	SPQ	Reel Diameter (mm)	Reel Width W1 (mm)	A0 (mm)	B0 (mm)	K0 (mm)	P1 (mm)	W (mm)	Pin1 Quadrant
CDCUN1208LPRHBR	VQFN	RHB	32	3000	330.0	12.4	5.3	5.3	1.1	8.0	12.0	Q2
CDCUN1208LPRHBT	VQFN	RHB	32	250	180.0	12.4	5.3	5.3	1.1	8.0	12.0	Q2

**TAPE AND REEL BOX DIMENSIONS**

\*All dimensions are nominal

Device	Package Type	Package Drawing	Pins	SPQ	Length (mm)	Width (mm)	Height (mm)
CDCUN1208LPRHBR	VQFN	RHB	32	3000	346.0	346.0	33.0
CDCUN1208LPRHBT	VQFN	RHB	32	250	182.0	182.0	20.0



## GENERIC PACKAGE VIEW

**RHB 32**

**VQFN - 1 mm max height**

5 x 5, 0.5 mm pitch

PLASTIC QUAD FLATPACK - NO LEAD

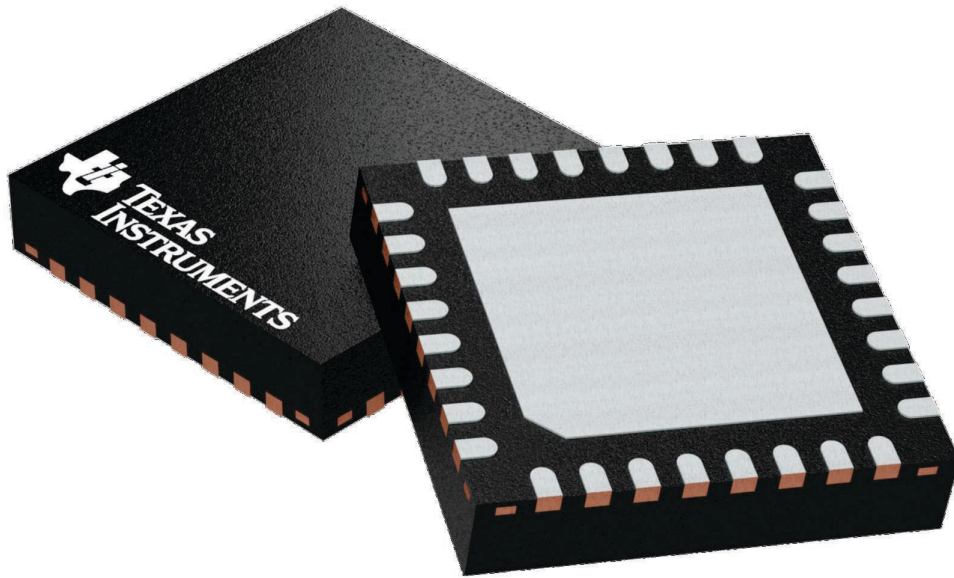

Images above are just a representation of the package family, actual package may vary.  
Refer to the product data sheet for package details.

4224745/A

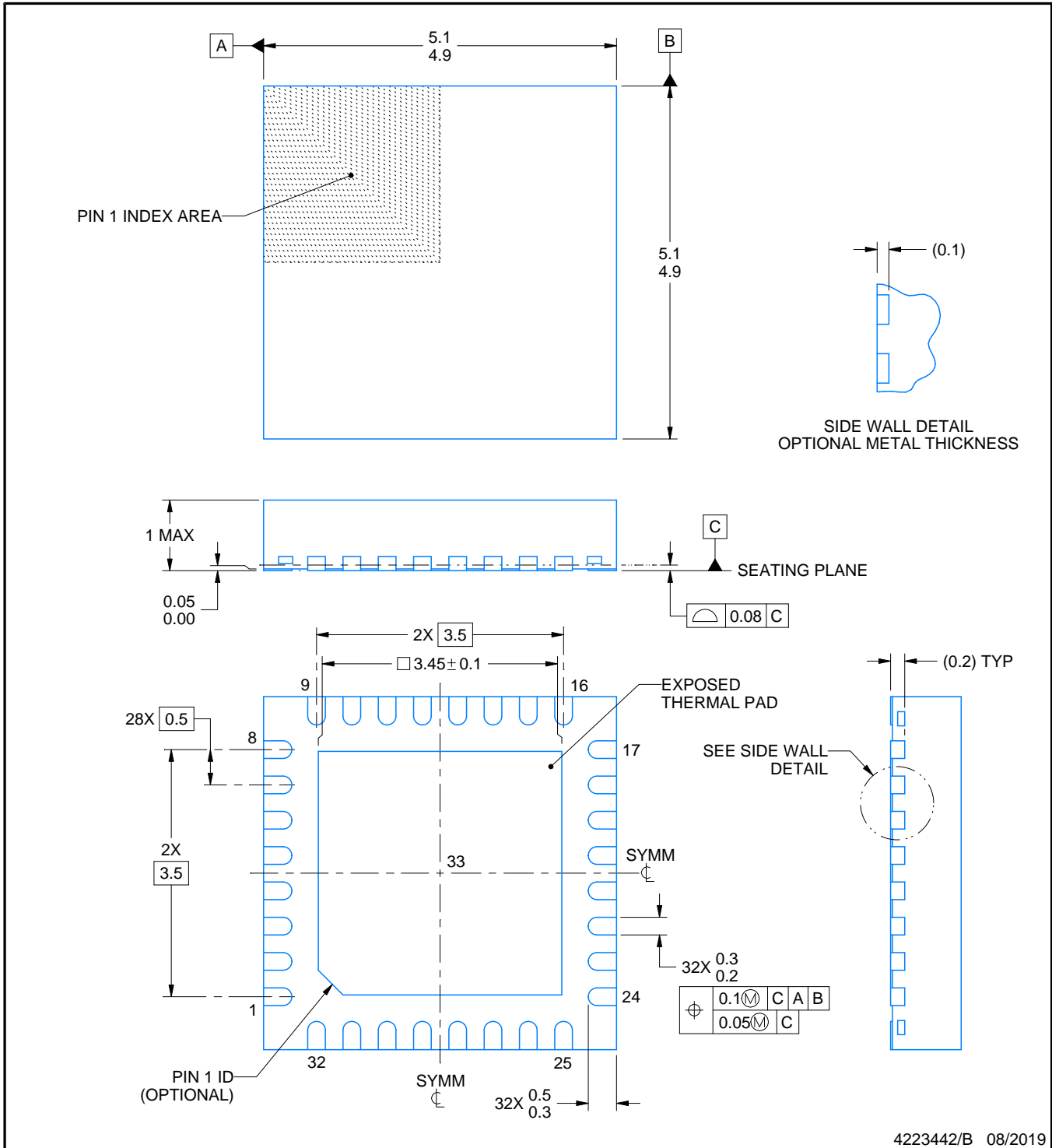

4223442/B 08/2019

NOTES:

1. All linear dimensions are in millimeters. Any dimensions in parenthesis are for reference only. Dimensioning and tolerancing per ASME Y14.5M.
2. This drawing is subject to change without notice.
3. The package thermal pad must be soldered to the printed circuit board for thermal and mechanical performance.

# EXAMPLE BOARD LAYOUT

RHB0032E

VQFN - 1 mm max height

PLASTIC QUAD FLATPACK - NO LEAD



LAND PATTERN EXAMPLE  
SCALE:18X



SOLDER MASK DETAILS

4223442/B 08/2019

NOTES: (continued)

4. This package is designed to be soldered to a thermal pad on the board. For more information, see Texas Instruments literature number SLUA271 ([www.ti.com/lit/sluea271](http://www.ti.com/lit/sluea271)).
5. Vias are optional depending on application, refer to device data sheet. If any vias are implemented, refer to their locations shown on this view. It is recommended that vias under paste be filled, plugged or tented.

# EXAMPLE STENCIL DESIGN

RHB0032E

VQFN - 1 mm max height

PLASTIC QUAD FLATPACK - NO LEAD

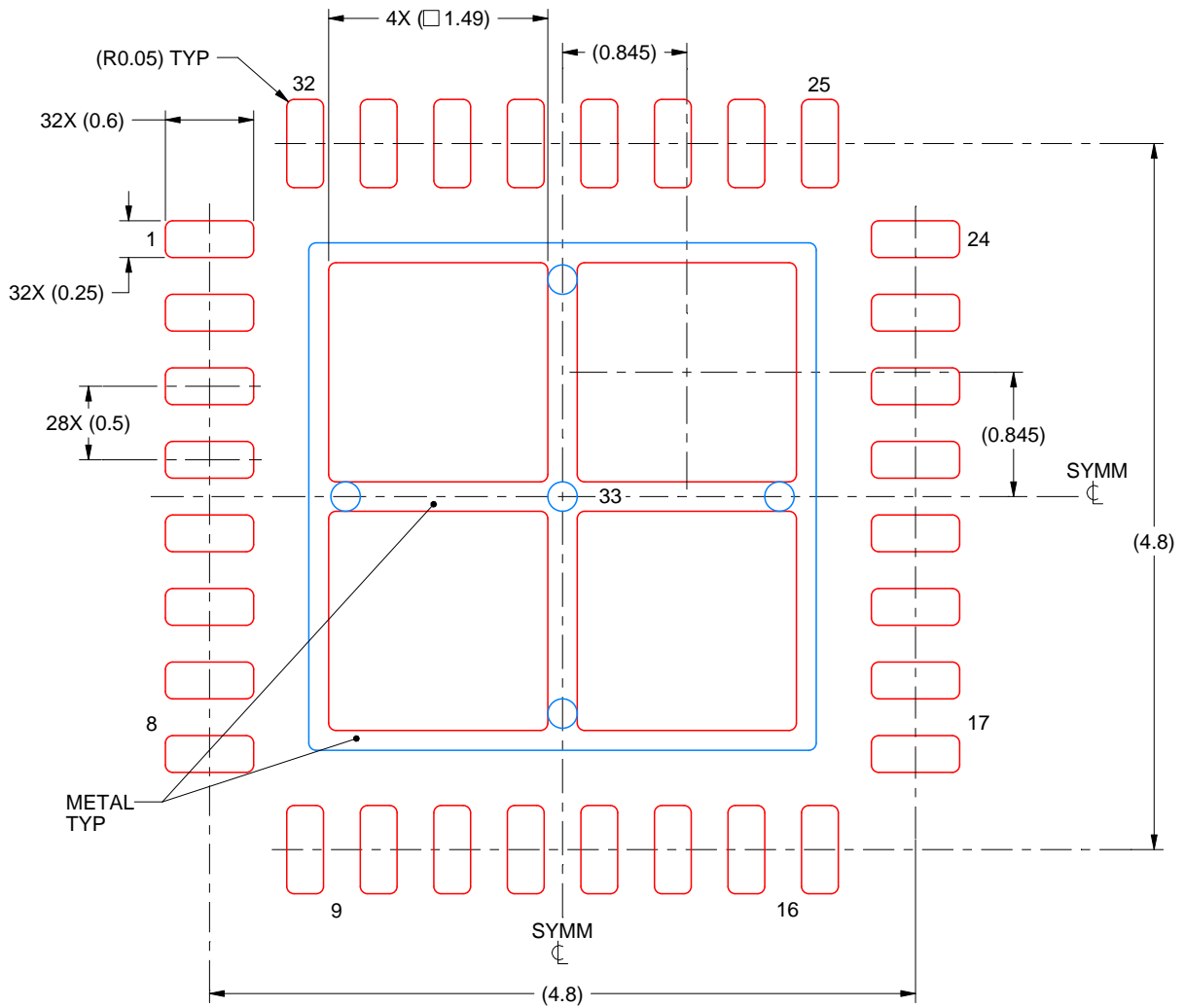

**SOLDER PASTE EXAMPLE**  
 BASED ON 0.125 mm THICK STENCIL

EXPOSED PAD 33:  
 75% PRINTED SOLDER COVERAGE BY AREA UNDER PACKAGE  
 SCALE:20X

4223442/B 08/2019

NOTES: (continued)

6. Laser cutting apertures with trapezoidal walls and rounded corners may offer better paste release. IPC-7525 may have alternate design recommendations.

## 重要通知和免责声明

TI“按原样”提供技术和可靠性数据（包括数据表）、设计资源（包括参考设计）、应用或其他设计建议、网络工具、安全信息和其他资源，不保证没有瑕疵且不做任何明示或暗示的担保，包括但不限于对适销性、某特定用途方面的适用性或不侵犯任何第三方知识产权的暗示担保。

这些资源可供使用 TI 产品进行设计的熟练开发人员使用。您将自行承担以下全部责任：(1) 针对您的应用选择合适的 TI 产品，(2) 设计、验证并测试您的应用，(3) 确保您的应用满足相应标准以及任何其他功能安全、信息安全、监管或其他要求。

这些资源如有变更，恕不另行通知。TI 授权您仅可将这些资源用于研发本资源所述的 TI 产品的相关应用。严禁以其他方式对这些资源进行复制或展示。您无权使用任何其他 TI 知识产权或任何第三方知识产权。您应全额赔偿因在这些资源的使用中对 TI 及其代表造成的任何索赔、损害、成本、损失和债务，TI 对此概不负责。

TI 提供的产品受 [TI 的销售条款](#) 或 [ti.com](#) 上其他适用条款/TI 产品随附的其他适用条款的约束。TI 提供这些资源并不会扩展或以其他方式更改 TI 针对 TI 产品发布的适用的担保或担保免责声明。

TI 反对并拒绝您可能提出的任何其他或不同的条款。

邮寄地址：Texas Instruments, Post Office Box 655303, Dallas, Texas 75265  
版权所有 © 2025，德州仪器 (TI) 公司