

具有射频内核的 **CC430F613x**、**CC430F612x**、**CC430F513x** **MSP430™ SoC**

1 器件概述

1.1 特性

- 用于低功耗无线通信应用的真正片上系统 (SoC)
- 宽电源电压范围：
1.8V 至 3.6V
- 超低功耗
 - CPU 激活模式 (AM): 160 μ A/MHz
 - 待机模式 (LPM3 实时时钟 (RTC) 模式): 2.0 μ A
 - 关闭模式 (LPM4 RAM 保持): 1.0 μ A
 - RX 中的射频: 15mA, 250kbps, 915MHz
- MSP430™ 系统和外设
 - 16 位精简指令集 (RISC) 架构、扩展内存、高达 20MHz 的系统时钟
 - 可在不到 6 μ s 的时间内从待机模式唤醒
 - 具有 SVS 和欠压复位功能的灵活电源管理解决方案
 - 配有的锁频环 (FLL) 的统一系统时钟
 - 配有 5 个捕捉/比较寄存器的 16 位定时器 TA0, Timer_A
 - 具有 3 个捕捉/比较寄存器的 16 位定时器 TA1, Timer_A
 - 硬件实时时钟 (RTC)
 - 两个通用串行通信接口 (USCI)
 - USCI_A0 支持 UART、IrDA 和 SPI
 - USCI_B0 支持 I²C 和 SPI
 - 具有内部基准、采样保持以及自动扫描特性的 12 位模数转换器 (ADC) (仅限 CC430F613x 和 CC430F513x)
 - 比较器
 - 具有高达 96 段对比度控制的集成 LCD 驱动器 (仅限 CC430F61xx)
 - 128 位高级加密标准 (AES) 安全加密和解密协处理器
- 高性能低于 1GHz 射频收发器内核
 - 与 CC1101 中的内核一致
 - 宽电源电压范围: 2V 至 3.6V
 - 频带范围: 300MHz 至 348MHz, 389MHz 至 464MHz, 和 779MHz 至 928MHz
 - 从 0.6 千波特率 (kbaud) 至 500 kbaud 间的可编程数据传输速率
 - 高灵敏度 (0.6kBaude 时为 -117dBm, 1.2kBaude 时为 -111dBm, 315MHz, 1% 的误包率)
 - 出色的接收器可选择性和阻断性能
 - 对于所有支持的频率, 可编程输出功率高达 +12dBm
 - 支持 2-FSK、2-GFSK 和 MSK, 以及 OOK 和灵活的 ASK 整形
 - 针对面向数据包系统的灵活支持: 用于同步字检测、地址检查、灵活数据包长度、和自动循环冗余校验码处理的片载支持
 - 支持传输前的自动空闲信道评估 (CCA) (针对对话前监听系统)
 - 接收到的信号强度指示器 (RSSI) 数字输出
 - 适合于符合 EN 300 220 (欧洲) 和 FCC CFR 部分 15 (美国) 标准的系统
 - 适用于需要满足无线 M-Bus 标准 EN 13757-4:2005 的系统
 - 支持异步和同步串行接收或传输模式, 以向后兼容现有无线电通信协议
- [器件比较](#) 汇总了可用的产品系列成员

1.2 应用

- 无线模拟和数字传感器系统
- 热量分配表
- 恒温器
- AMR 或 AMI 计量
- 智能电网无线网络

1.3 说明

TI CC430 系列超低功耗片上系统 (SoC) 微控制器搭载有集成射频收发器内核, 并包含数个采用各种不同外设集的器件, 可广泛应用于各种应用。此架构经过优化, 与五种低功耗模式相配合使用, 可延长便携式测量应用中的电池寿命。该器件具有功能强大的 MSP430 16 位 RISC CPU、16 位寄存器和有助于获得最大编码效率的常数发生器。



CC430 系列器件将微控制器内核、外设、软件和射频收发器紧密集成在一起，从而使得这些真正的 SoC 解决方案方便易用，同时性能也得以提高。

CC430F61xx 系列采用微控制器 SoC 配置，将先进的 CC1101 低于 1GHz 射频收发器的出色性能与 MSP430 CPUXV2 相结合，提供高达 32KB 的系统内可编程闪存、高达 4KB 的 RAM、两个 16 位计时器、一个具有 8 个外部输入端以及 CC430F613x 器件上所设的多个内部温度和电池传感器的 12 位高性能 ADC、一个比较器、USCI、一个 128 位 AES 安全加速器、一个硬件乘法器、一个 DMA、一个带报警功能的 RTC 模块、一个 LCD 驱动器，以及多达 44 个 I/O 引脚。

CC430F513x 系列采用微控制器 SoC 配置，将先进的 CC1101 低于 1GHz 射频收发器的出色性能与 MSP430 CPUXV2 相结合，提供高达 32KB 的系统内可编程闪存、高达 4KB 的 RAM、两个 16 位计时器、一个具有 6 个外部输入端以及多个内部温度和电池传感器的 12 位高性能 ADC、一个比较器、USCI、一个 128 位 AES 安全加速器、一个硬件乘法器、一个 DMA、一个带报警功能的 RTC 模块、一个 LCD 驱动器，以及多达 30 个 I/O 引脚。

如需完整的模块说明，请参阅 [《CC430 系列用户指南》](#)

器件信息⁽¹⁾

器件型号	封装	封装尺寸 ⁽²⁾
CC430F6137IRGC	VQFN (64)	9mm x 9mm
CC430F5137IRGZ	VQFN (48)	7mm x 7mm

(1) 要获得最新的产品、封装和订购信息，请参见封装选项附录（节 9），或者访问德州仪器 (TI) 网站 www.ti.com.cn。

(2) 这里显示的尺寸为近似值。要获得包含误差值的封装尺寸，请参见机械数据（节 9）。

1.4 功能方框图

图 1-1 显示了 CC430F613x 功能方框图。

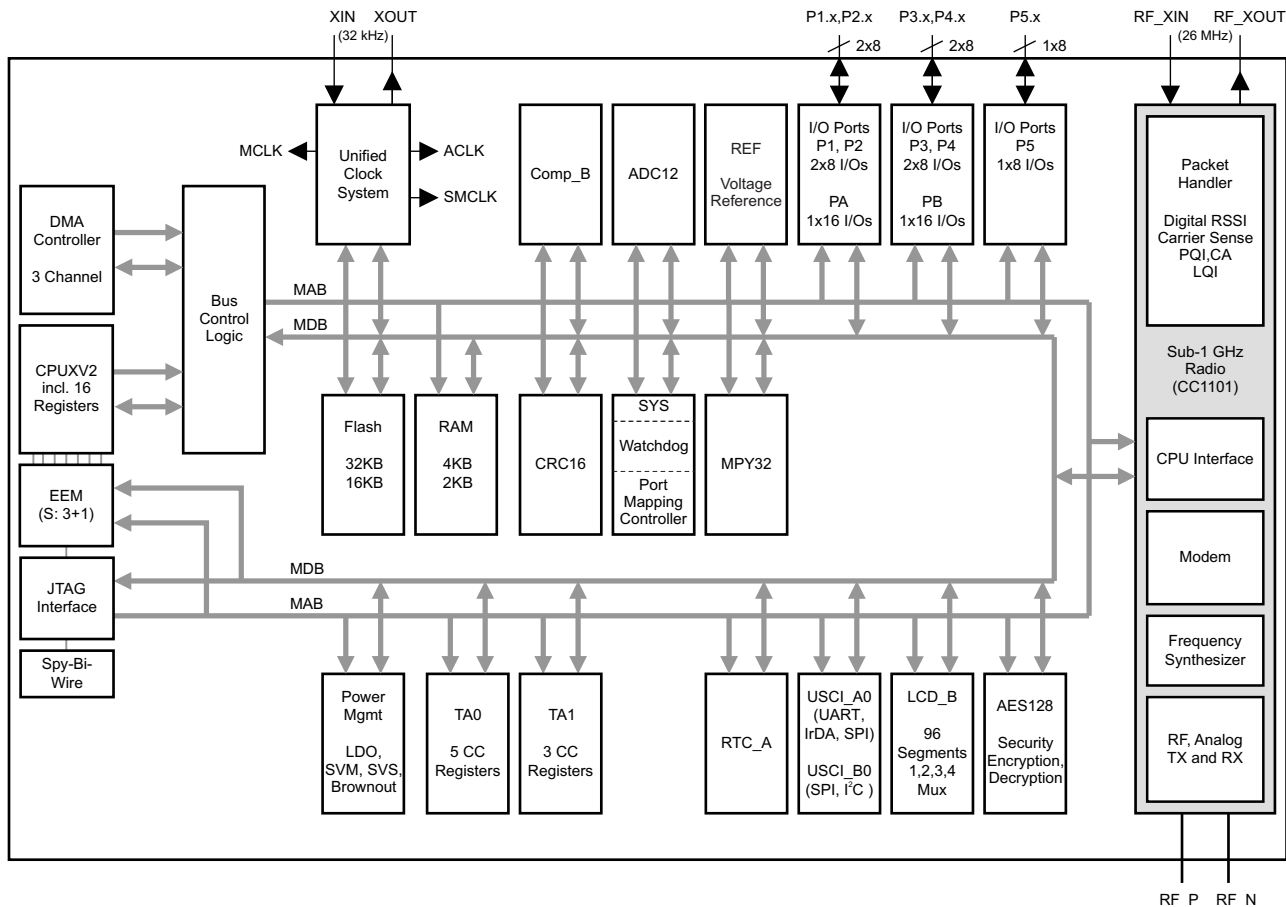

Copyright © 2017, Texas Instruments Incorporated

图 1-1. CC430F613x 功能方框图

图 1-2 显示了 CC430F612x 功能方框图。

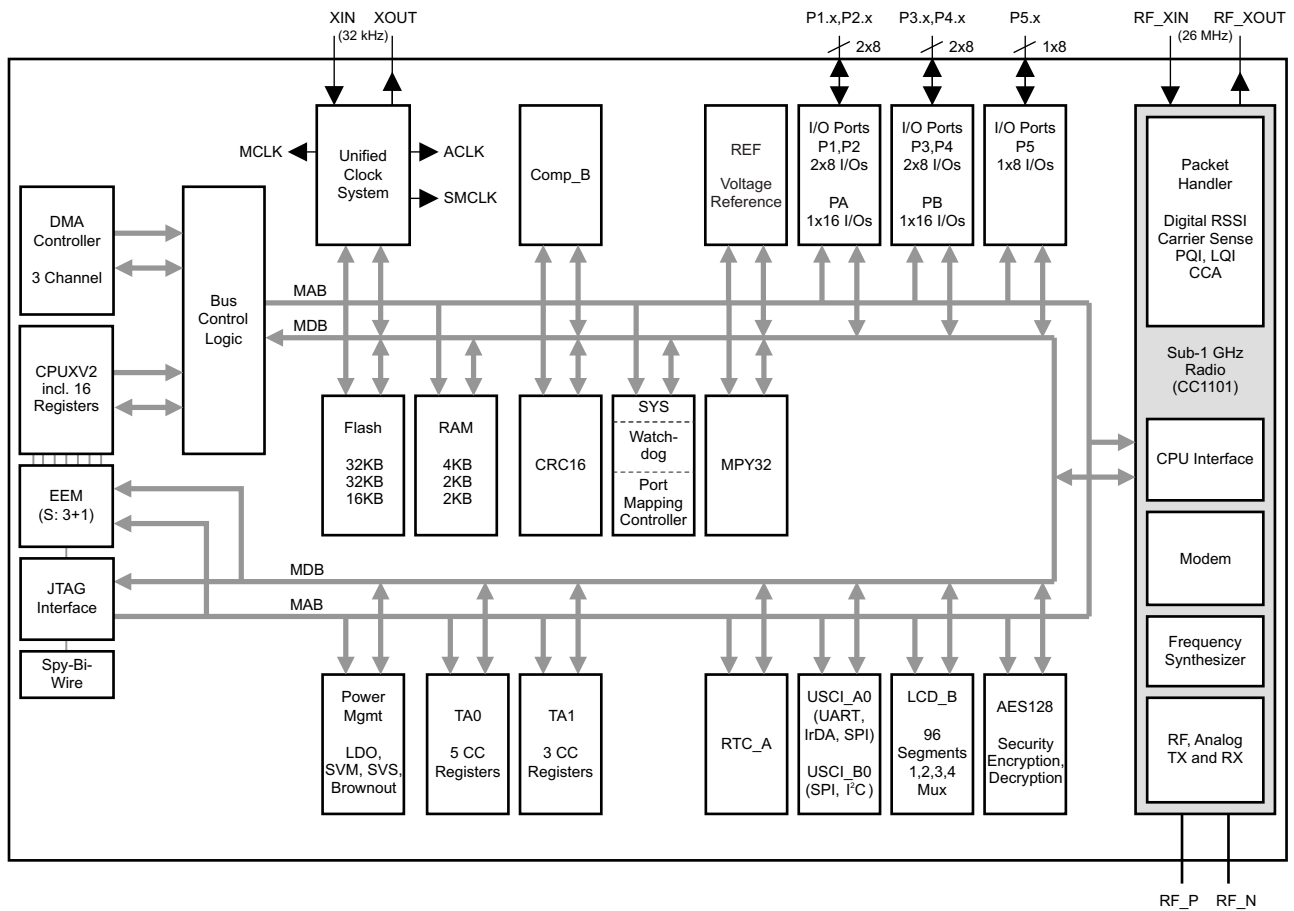

Copyright © 2017, Texas Instruments Incorporated

图 1-2. CC430F612x 功能方框图

图 1-3 显示了 CC430F513x 功能方框图。

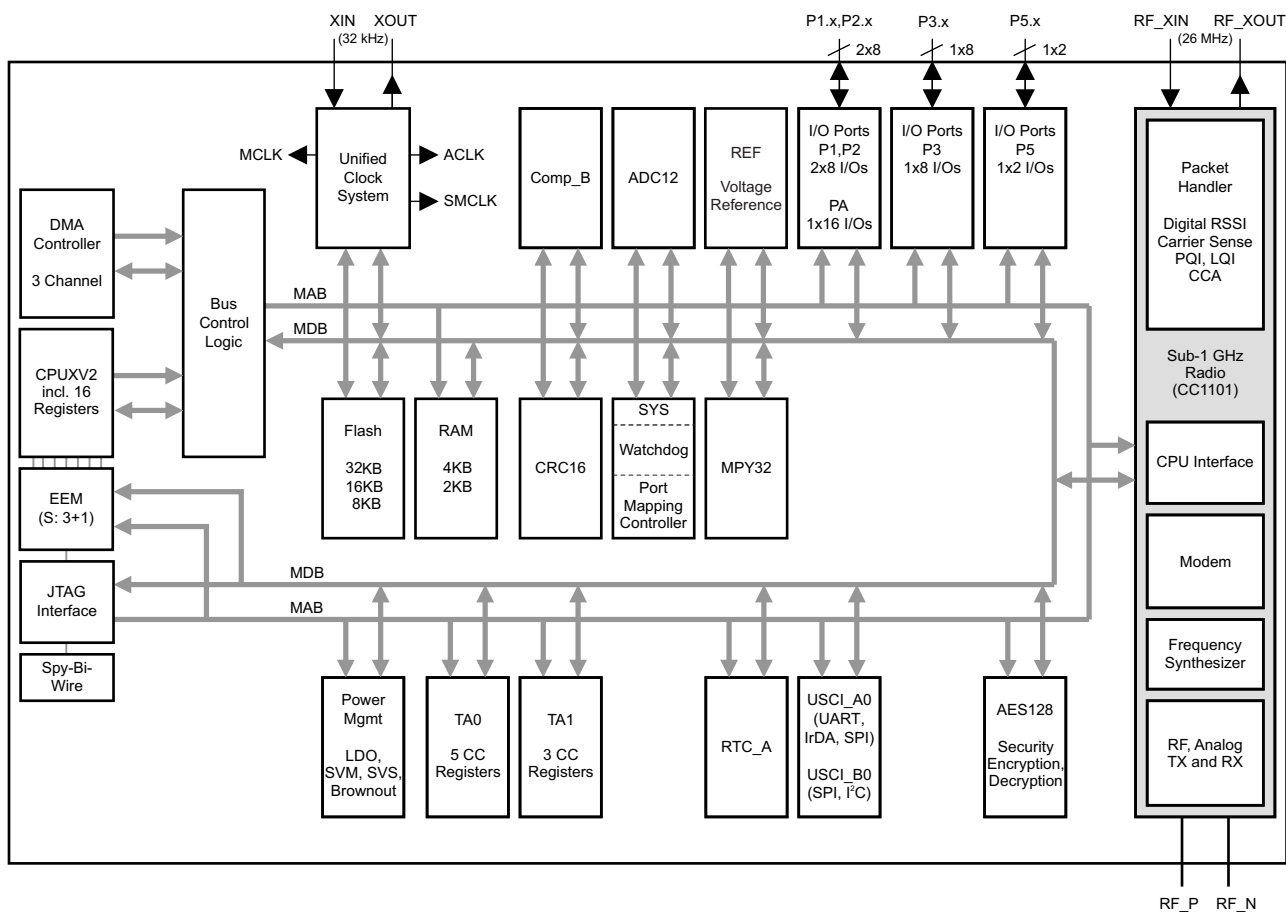

Copyright © 2017, Texas Instruments Incorporated

图 1-3. CC430F513x 功能方框图

2 修订历史记录

注：之前版本的页码可能与当前版本有所不同。

Changes from September 6, 2013 to September 17, 2018	Page
• 已通篇更改格式和结构，其中包括添加章节编号.....	1
• 添加了器件信息表.....	2
• 添加了节 1.4 并将所有功能框图移到这里.....	3
• Added Section 3, <i>Device Comparison</i> , and moved Table 3-1 to it.....	7
• Added Section 3.1, <i>Related Products</i>	7
• Added Section 4, <i>Terminal Configuration and Functions</i> , and moved all pinouts and terminal functions tables to it ...	8
• Added typical conditions statements at the beginning of Section 5, <i>Specifications</i>	17
• Added Section 5, <i>Specifications</i> , and moved all electrical and timing specifications to it	17
• Added Section 5.2, <i>ESD Ratings</i>	17
• Changed the MIN value of the $V_{(DVCC_BOR_hys)}$ parameter from 60 mV to 50 mV in Section 5.19, <i>PMM, Brownout Reset (BOR)</i>	29
• Updated notes (1) and (2) and added note (3) in Section 5.25, <i>Wake-up Times From Low-Power Modes and Reset</i>	31
• Removed ADC12DIV from the formula for the TYP value in the second row of the $t_{CONVERT}$ parameter in Section 5.36, <i>12-Bit ADC, Timing Parameters</i> (removed because ADC12CLK is after division).....	39
• For the t_{EN_CMP} parameter in Section 5.42, <i>Comparator_B</i> : Removed "CBPWRMD = 10" from the Test Conditions in the first row; added second row with Test Conditions of "CBPWRMD = 10" and a MAX value of 100 μ s.....	44
• Changed the test conditions "RF crystal oscillator only" and added note in Section 5.48, <i>Current Consumption, Reduced-Power Modes</i>	46
• Corrected the link for <i>DN013 Programming Output Power on CC1101</i>	56
• Changed all instances of "bootstrap loader" to "bootloader" throughout document.....	65
• Corrected spelling of NMIIFG in Table 6-8, <i>System Module Interrupt Vector Registers</i>	70
• 增加了节 8 器件和文档支持 并将器件命名规则、ESD 注意事项 和商标 部分移到这里	112
• 增加了节 9, 机械, 封装和可订购信息.....	118

3 Device Comparison

Table 3-1 summarizes the available family members.

Table 3-1. Device Comparison⁽¹⁾⁽²⁾

DEVICE	PROGRAM (KB)	SRAM (KB)	Timer_A ⁽³⁾	LCD_B	USCI		ADC12_A CHANNELS	COMP_B CHANNELS	I/O	PACKAGE
					CHANNEL A: UART, LIN, IrDA, SPI	CHANNEL B: SPI, I ² C				
CC430F6137	32	4	5, 3	96 seg	1	1	8 ext, 4 int	8	44	64 RGC
CC430F6135	16	2	5, 3	96 seg	1	1	8 ext, 4 int	8	44	64 RGC
CC430F6127	32	4	5, 3	96 seg	1	1	N/A ⁽⁴⁾	8	44	64 RGC
CC430F6126	32	2	5, 3	96 seg	1	1	N/A	8	44	64 RGC
CC430F6125	16	2	5, 3	96 seg	1	1	N/A	8	44	64 RGC
CC430F5137	32	4	5, 3	N/A ⁽⁴⁾	1	1	6 ext, 4 int	6	30	48 RGZ
CC430F5135	16	2	5, 3	N/A	1	1	6 ext, 4 int	6	30	48 RGZ
CC430F5133	8	2	5, 3	N/A	1	1	6 ext, 4 int	6	30	48 RGZ

- (1) For the most current device, package, and ordering information, see the *Package Option Addendum* in [§ 9](#), or see the TI website at www.ti.com.
- (2) Package drawings, thermal data, and symbolization are available at www.ti.com/packaging.
- (3) Each number in the sequence represents an instantiation of Timer_A with its associated number of capture/compare registers and PWM output generators available. For example, a number sequence of 5, 3 represents two instantiations of Timer_A, the first instantiation having 5 capture/compare registers and PWM output generators, and the second instantiation having 3 capture/compare registers and PWM output generators, respectively.
- (4) N/A = not available

3.1 Related Products

For information about other devices in this family of products or related products, see the following links.

Products for TI Microcontrollers TI's low-power and high-performance MCUs, with wired and wireless connectivity options, are optimized for a broad range of applications.

Products for MSP430 Ultra-Low-Power Microcontrollers One platform. One ecosystem. Endless possibilities. Enabling the connected world with innovations in ultra-low-power microcontrollers with advanced peripherals for precise sensing and measurement.

Companion Products for CC430F6137 Review products that are frequently purchased or used in conjunction with this product.

Reference Designs for CC430F6137 TI Designs Reference Design Library is a robust reference design library that spans analog, embedded processor, and connectivity. Created by TI experts to help you jump start your system design, all TI Designs include schematic or block diagrams, BOMs, and design files to speed your time to market. Search and download designs at ti.com/tidesigns.

4 Terminal Configuration and Functions

4.1 Pin Diagrams

Figure 4-1 shows the pinout for the CC430F613x devices in the 64-pin RGC package.

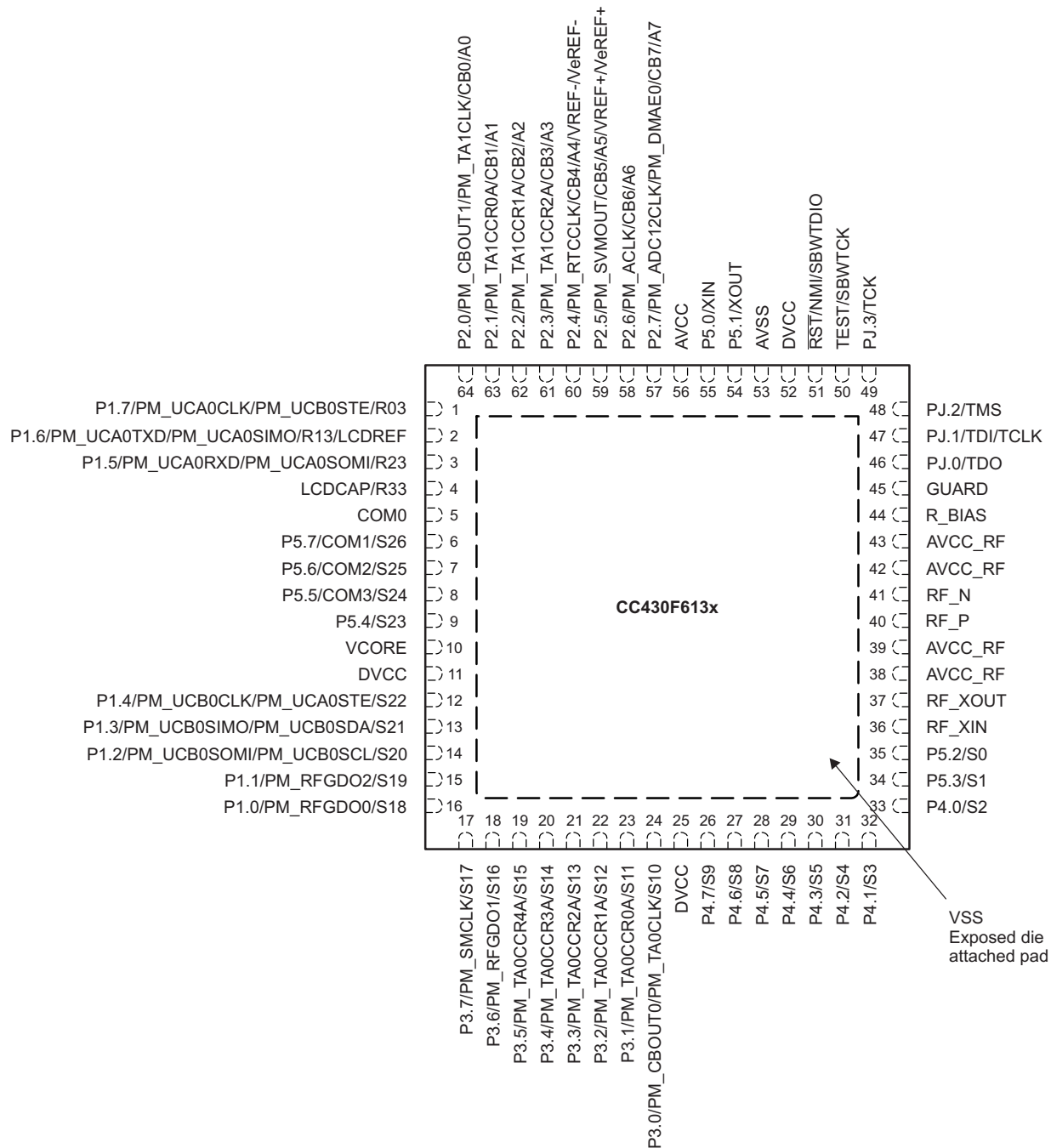

CAUTION: The LCDCAP/R33 must be connected to VSS if not used.

NOTE: The secondary digital functions on ports P1, P2, and P3 are fully mappable. This pinout shows only the default mapping. See Table 6-6 for details.

Figure 4-1. 64-Pin RGC Package (Top View), CC430F613x

Figure 4-2 shows the pinout for the CC430F612x devices in the 64-pin RGC package.

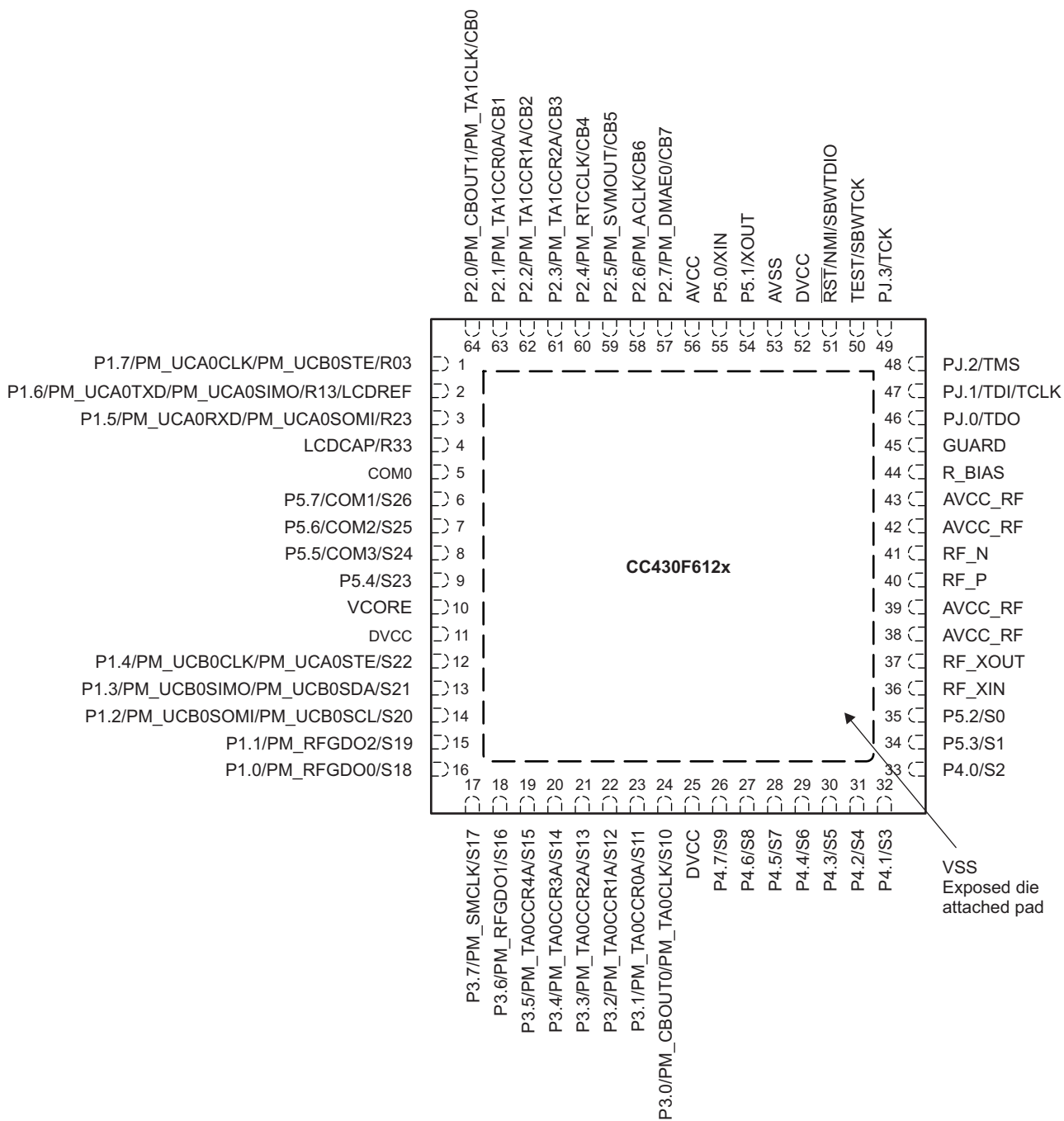

CAUTION: The LCDCAP/R33 must be connected to VSS if not used.

NOTE: The secondary digital functions on ports P1, P2, and P3 are fully mappable. This pinout shows only the default mapping. See Table 6-6 for details.

Figure 4-2. 64-Pin RGC Package (Top View), CC430F612x

Figure 4-3 shows the pinout for the CC430F513x devices in the 48-pin RGZ package.

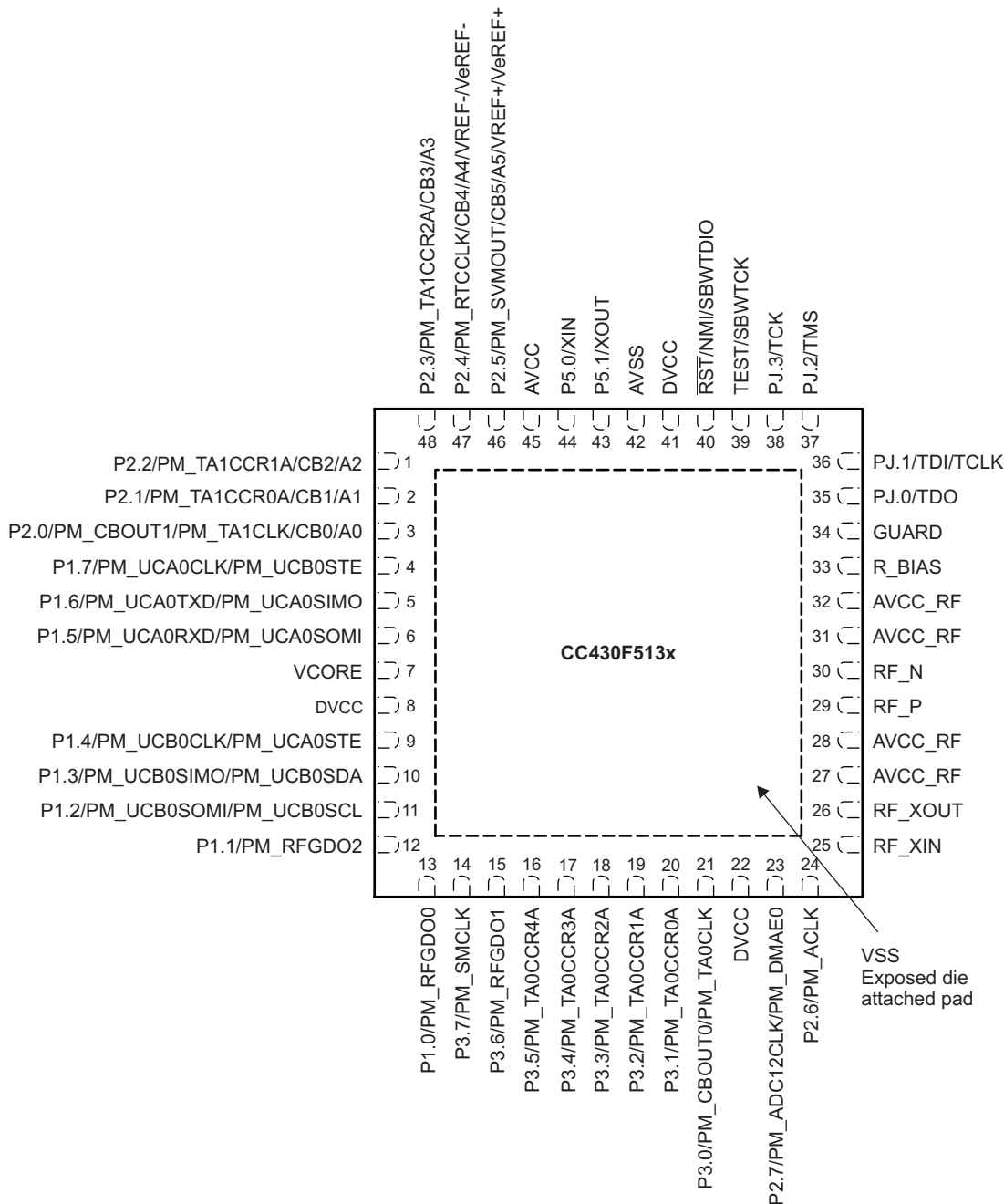

NOTE: The secondary digital functions on ports P1, P2, and P3 are fully mappable. This pinout shows only the default mapping. See Table 6-6 for details.

Figure 4-3. 48-Pin RGZ Package (Top View), CC430F513x

4.2 Signal Descriptions

Table 4-1 describes the signals for the CC430F613x and CC430F612x devices. See Table 4-2 for the CC430F513x devices.

Table 4-1. CC430F613x and CC430F612x Terminal Functions

TERMINAL		I/O ⁽¹⁾	DESCRIPTION
NAME	NO.		
P1.7/ PM_UCA0CLK/ PM_UCB0STE/ R03	1	I/O	General-purpose digital I/O with port interrupt and mappable secondary function Default mapping: USCI_A0 clock input/output; USCI_B0 SPI slave transmit enable Input/output port of lowest analog LCD voltage (V5)
P1.6/ PM_UCA0TXD/ PM_UCA0SIMO/ R13/LCDREF	2	I/O	General-purpose digital I/O with port interrupt and mappable secondary function Default mapping: USCI_A0 UART transmit data; USCI_A0 SPI slave in master out Input/output port of third most positive analog LCD voltage (V3 or V4) External reference voltage input for regulated LCD voltage
P1.5/ PM_UCA0RXD/ PM_UCA0SOMI/ R23	3	I/O	General-purpose digital I/O with port interrupt and mappable secondary function Default mapping: USCI_A0 UART receive data; USCI_A0 SPI slave out master in Input/output port of second most positive analog LCD voltage (V2)
LDCAP/ R33	4	I/O	LCD capacitor connection Input/output port of most positive analog LCD voltage (V1) CAUTION: Must be connected to VSS if not used.
COM0	5	O	LCD common output COM0 for LCD backplane
P5.7/ COM1/ S26	6	I/O	General-purpose digital I/O LCD common output COM1 for LCD backplane LCD segment output S26
P5.6/ COM2/ S25	7	I/O	General-purpose digital I/O LCD common output COM2 for LCD backplane LCD segment output S25
P5.5/ COM3/ S24	8	I/O	General-purpose digital I/O LCD common output COM3 for LCD backplane LCD segment output S24
P5.4/ S23	9	I/O	General-purpose digital I/O LCD segment output S23
VCORE	10		Regulated core power supply
DVCC	11		Digital power supply
P1.4/ PM_UCB0CLK/ PM_UCA0STE/ S22	12	I/O	General-purpose digital I/O with port interrupt and mappable secondary function Default mapping: USCI_B0 clock input/output Default mapping: USCI_A0 SPI slave transmit enable LCD segment output S22
P1.3/ PM_UCB0SIMO/ PM_UCB0SDA/ S21	13	I/O	General-purpose digital I/O with port interrupt and mappable secondary function Default mapping: USCI_B0 SPI slave in master out Default mapping: USCI_B0 I ² C data LCD segment output S21
P1.2/ PM_UCB0SOMI/ PM_UCB0SCL/ S20	14	I/O	General-purpose digital I/O with port interrupt and mappable secondary function Default mapping: USCI_B0 SPI slave out master in Default mapping: USCI_B0 I ² C clock LCD segment output S20
P1.1/ PM_RFGDO2/ S19	15	I/O	General-purpose digital I/O with port interrupt and mappable secondary function Default mapping: Radio GDO2 output LCD segment output S19
P1.0/ PM_RFGDO0/ S18	16	I/O	General-purpose digital I/O with port interrupt and mappable secondary function Default mapping: Radio GDO0 output LCD segment output S18
P3.7/ PM_SMCLK/ S17	17	I/O	General-purpose digital I/O with mappable secondary function Default mapping: SMCLK output LCD segment output S17
P3.6/ PM_RFGDO1/ S16	18	I/O	General-purpose digital I/O with mappable secondary function Default mapping: Radio GDO1 output LCD segment output S16

(1) I = input, O = output

Table 4-1. CC430F613x and CC430F612x Terminal Functions (continued)

TERMINAL		I/O ⁽¹⁾	DESCRIPTION
NAME	NO.		
P3.5/ PM_TA0CCR4A/ S15	19	I/O	General-purpose digital I/O with mappable secondary function Default mapping: TA0 CCR4 compare output or capture input LCD segment output S15
P3.4/ PM_TA0CCR3A/ S14	20	I/O	General-purpose digital I/O with mappable secondary function Default mapping: TA0 CCR3 compare output or capture input LCD segment output S14
P3.3/ PM_TA0CCR2A/ S13	21	I/O	General-purpose digital I/O with mappable secondary function Default mapping: TA0 CCR2 compare output or capture input LCD segment output S13
P3.2/ PM_TA0CCR1A/ S12	22	I/O	General-purpose digital I/O with mappable secondary function Default mapping: TA0 CCR1 compare output or capture input LCD segment output S12
P3.1/ PM_TA0CCR0A/ S11	23	I/O	General-purpose digital I/O with mappable secondary function Default mapping: TA0 CCR0 compare output or capture input LCD segment output S11
P3.0/ PM_CBOU0/ PM_TA0CLK/ S10	24	I/O	General-purpose digital I/O with mappable secondary function Default mapping: Comparator_B output Default mapping: TA0 clock input LCD segment output S10
DVCC	25		Digital power supply
P4.7/ S9	26	I/O	General-purpose digital I/O LCD segment output S9
P4.6/ S8	27	I/O	General-purpose digital I/O LCD segment output S8
P4.5/ S7	28	I/O	General-purpose digital I/O LCD segment output S7
P4.4/ S6	29	I/O	General-purpose digital I/O LCD segment output S6
P4.3/ S5	30	I/O	General-purpose digital I/O LCD segment output S5
P4.2/ S4	31	I/O	General-purpose digital I/O LCD segment output S4
P4.1/ S3	32	I/O	General-purpose digital I/O LCD segment output S3
P4.0/ S2	33	I/O	General-purpose digital I/O LCD segment output S2
P5.3/ S1	34	I/O	General-purpose digital I/O LCD segment output S1
P5.2/ S0	35	I/O	General-purpose digital I/O LCD segment output S0
RF_XIN	36	I	Input terminal for RF crystal oscillator, or external clock input
RF_XOUT	37	O	Output terminal for RF crystal oscillator
AVCC_RF	38		Radio analog power supply
AVCC_RF	39		Radio analog power supply
RF_P	40	RF I/O	Positive RF input to LNA in receive mode Positive RF output from PA in transmit mode
RF_N	41	RF I/O	Negative RF input to LNA in receive mode Negative RF output from PA in transmit mode
AVCC_RF	42		Radio analog power supply
AVCC_RF	43		Radio analog power supply
RBIAS	44		External bias resistor for radio reference current
GUARD	45		Power supply connection for digital noise isolation
PJ.0/ TDO	46	I/O	General-purpose digital I/O Test data output port

Table 4-1. CC430F613x and CC430F612x Terminal Functions (continued)

TERMINAL		I/O ⁽¹⁾	DESCRIPTION
NAME	NO.		
PJ.1/ TDI/ TCLK	47	I/O	General-purpose digital I/O Test data input or test clock input
PJ.2/ TMS	48	I/O	General-purpose digital I/O Test mode select
PJ.3/ TCK	49	I/O	General-purpose digital I/O Test clock
TEST/ SBWTCK	50	I	Test mode pin – select digital I/O on JTAG pins Spy-Bi-Wire input clock
$\overline{\text{RST}}/\text{NMI}/ \text{SBWTDIO}$	51	I/O	Reset input active low Nonmaskable interrupt input Spy-Bi-Wire data input/output
DVCC	52		Digital power supply
AVSS	53		Analog ground supply for ADC12
P5.1/ XOUT	54	I/O	General-purpose digital I/O Output terminal of crystal oscillator XT1
P5.0/ XIN	55	I/O	General-purpose digital I/O Input terminal for crystal oscillator XT1
AVCC	56		Analog power supply
P2.7/ PM_ADC12CLK/ PM_DMAE0/ CB7 (/A7)	57	I/O	General-purpose digital I/O with port interrupt and mappable secondary function Default mapping: ADC12CLK output Default mapping: DMA external trigger input Comparator_B input CB7 Analog input A7 – 12-bit ADC (CC430F613x only)
P2.6/ PM_ACLK/ CB6 (/A6)	58	I/O	General-purpose digital I/O with port interrupt and mappable secondary function Default mapping: ACLK output Comparator_B input CB6 Analog input A6 – 12-bit ADC (CC430F613x only)
P2.5/ PM_SVMOUT/ CB5 (/A5/ VREF+/ VeREF+)	59	I/O	General-purpose digital I/O with port interrupt and mappable secondary function Default mapping: SVM output Comparator_B input CB5 Analog input A5 – 12-bit ADC (CC430F613x only) Output of reference voltage to the ADC (CC430F613x only) Input for an external reference voltage to the ADC (CC430F613x only)
P2.4/ PM_RTCCLK/ CB4 (/A4/ VREF-/ VeREF-)	60	I/O	General-purpose digital I/O with port interrupt and mappable secondary function Default mapping: RTCCLK output Comparator_B input CB4 Analog input A4 – 12-bit ADC (CC430F613x only) Negative terminal for the ADC reference voltage for both sources, the internal reference voltage, or an external applied reference voltage (CC430F613x only)
P2.3/ PM_TA1CCR2A/ CB3 (/A3)	61	I/O	General-purpose digital I/O with port interrupt and mappable secondary function Default mapping: TA1 CCR2 compare output or capture input Comparator_B input CB3 Analog input A3 – 12-bit ADC (CC430F613x only)
P2.2/ PM_TA1CCR1A/ CB2 (/A2)	62	I/O	General-purpose digital I/O with port interrupt and mappable secondary function Default mapping: TA1 CCR1 compare output or capture input Comparator_B input CB2 Analog input A2 – 12-bit ADC (CC430F613x only)
P2.1/ PM_TA1CCR0A/ CB1 (/A1)	63	I/O	General-purpose digital I/O with port interrupt and mappable secondary function Default mapping: TA1 CCR0 compare output or capture input Comparator_B input CB1 Analog input A1 – 12-bit ADC (CC430F613x only)
P2.0/ PM_CBOU1/ PM_TA1CLK/ CB0 (/A0)	64	I/O	General-purpose digital I/O with port interrupt and mappable secondary function Default mapping: Comparator_B output Default mapping: TA1 clock input Comparator_B input CB0 Analog input A0 – 12-bit ADC (CC430F613x only)
VSS, Exposed die attach pad			Ground supply CAUTION: The exposed die attach pad must be connected to a solid ground plane as this is the ground connection for the chip.

Table 4-2 describes the signals for the CC430F513x devices. See Table 4-1 for the CC430F613x and CC430F612x devices.

Table 4-2. CC430F513x Terminal Functions

TERMINAL		I/O ⁽¹⁾	DESCRIPTION
NAME	NO.		
P2.2/ PM_TA1CCR1A/ CB2/ A2	1	I/O	General-purpose digital I/O with port interrupt and mappable secondary function Default mapping: TA1 CCR1 compare output or capture input Comparator_B input CB2 Analog input A2 – 12-bit ADC
P2.1/ PM_TA1CCR0A/ CB1/ A1	2	I/O	General-purpose digital I/O with port interrupt and mappable secondary function Default mapping: TA1 CCR0 compare output or capture input Comparator_B input CB1 Analog input A1 – 12-bit ADC
P2.0/ PM_CBOUT1/ PM_TA1CLK/ CB0/ A0	3	I/O	General-purpose digital I/O with port interrupt and mappable secondary function Default mapping: Comparator_B output Default mapping: TA1 clock input Comparator_B input CB0 Analog input A0 – 12-bit ADC
P1.7/ PM_UCA0CLK/ PM_UCB0STE	4	I/O	General-purpose digital I/O with port interrupt and mappable secondary function Default mapping: USCI_A0 clock input/output Default mapping: USCI_B0 SPI slave transmit enable
P1.6/ PM_UCA0TXD/ PM_UCA0SIMO	5	I/O	General-purpose digital I/O with port interrupt and mappable secondary function Default mapping: USCI_A0 UART transmit data; USCI_A0 SPI slave in master out
P1.5/ PM_UCA0RXD/ PM_UCA0SOMI	6	I/O	General-purpose digital I/O with port interrupt and mappable secondary function Default mapping: USCI_A0 UART receive data Default mapping: USCI_A0 SPI slave out master in
VCORE	7		Regulated core power supply
DVCC	8		Digital power supply
P1.4/ PM_UCB0CLK/ PM_UCA0STE	9	I/O	General-purpose digital I/O with port interrupt and mappable secondary function Default mapping: USCI_B0 clock input/output Default mapping: USCI_A0 SPI slave transmit enable
P1.3/ PM_UCB0SIMO/ PM_UCB0SDA	10	I/O	General-purpose digital I/O with port interrupt and mappable secondary function Default mapping: USCI_B0 SPI slave in master out Default mapping: USCI_B0 I ² C data
P1.2/ PM_UCB0SOMI/ PM_UCB0SCL	11	I/O	General-purpose digital I/O with port interrupt and mappable secondary function Default mapping: USCI_B0 SPI slave out master in Default mapping: USCI_B0 I ² C clock
P1.1/ PM_RFGDO2	12	I/O	General-purpose digital I/O with port interrupt and mappable secondary function Default mapping: Radio GDO2 output
P1.0/ PM_RFGDO0	13	I/O	General-purpose digital I/O with port interrupt and mappable secondary function Default mapping: Radio GDO0 output
P3.7/ PM_SMCLK	14	I/O	General-purpose digital I/O with mappable secondary function Default mapping: SMCLK output
P3.6/ PM_RFGDO1	15	I/O	General-purpose digital I/O with mappable secondary function Default mapping: Radio GDO1 output
P3.5/ PM_TA0CCR4A	16	I/O	General-purpose digital I/O with mappable secondary function Default mapping: TA0 CCR4 compare output or capture input
P3.4/ PM_TA0CCR3A	17	I/O	General-purpose digital I/O with mappable secondary function Default mapping: TA0 CCR3 compare output or capture input
P3.3/ PM_TA0CCR2A	18	I/O	General-purpose digital I/O with mappable secondary function Default mapping: TA0 CCR2 compare output or capture input
P3.2/ PM_TA0CCR1A	19	I/O	General-purpose digital I/O with mappable secondary function Default mapping: TA0 CCR1 compare output or capture input
P3.1/ PM_TA0CCR0A	20	I/O	General-purpose digital I/O with mappable secondary function Default mapping: TA0 CCR0 compare output or capture input
P3.0/ PM_CBOUT0/ PM_TA0CLK	21	I/O	General-purpose digital I/O with mappable secondary function Default mapping: Comparator_B output Default mapping: TA0 clock input

(1) I = input, O = output

Table 4-2. CC430F513x Terminal Functions (continued)

TERMINAL		I/O ⁽¹⁾	DESCRIPTION
NAME	NO.		
DVCC	22		Digital power supply
P2.7/ PM_ADC12CLK/ PM_DMAE0	23	I/O	General-purpose digital I/O with port interrupt and mappable secondary function Default mapping: ADC12CLK output Default mapping: DMA external trigger input
P2.6/ PM_ACLK	24	I/O	General-purpose digital I/O with port interrupt and mappable secondary function Default mapping: ACLK output
RF_XIN	25	I	Input terminal for RF crystal oscillator, or external clock input
RF_XOUT	26	O	Output terminal for RF crystal oscillator
AVCC_RF	27		Radio analog power supply
AVCC_RF	28		Radio analog power supply
RF_P	29	RF I/O	Positive RF input to LNA in receive mode Positive RF output from PA in transmit mode
RF_N	30	RF I/O	Negative RF input to LNA in receive mode Negative RF output from PA in transmit mode
AVCC_RF	31		Radio analog power supply
AVCC_RF	32		Radio analog power supply
RBIAS	33		External bias resistor for radio reference current
GUARD	34		Power supply connection for digital noise isolation
PJ.0/ TDO	35	I/O	General-purpose digital I/O Test data output port
PJ.1/ TDI/ TCLK	36	I/O	General-purpose digital I/O Test data input or test clock input
PJ.2/ TMS	37	I/O	General-purpose digital I/O Test mode select
PJ.3/ TCK	38	I/O	General-purpose digital I/O Test clock
TEST/ SBWTCK	39	I	Test mode pin – select digital I/O on JTAG pins Spy-Bi-Wire input clock
$\overline{\text{RST}}/\text{NMI}/ \text{SBWTDIO}$	40	I/O	Reset input active low Nonmaskable interrupt input Spy-Bi-Wire data input/output
DVCC	41		Digital power supply
AVSS	42		Analog ground supply for ADC12
P5.1/ XOUT	43	I/O	General-purpose digital I/O Output terminal of crystal oscillator XT1
P5.0/ XIN	44	I/O	General-purpose digital I/O Input terminal for crystal oscillator XT1
AVCC	45		Analog power supply
P2.5/ PM_SVMOUT/ CB5/ A5/ VREF+/ VeREF+	46	I/O	General-purpose digital I/O with port interrupt and mappable secondary function Default mapping: SVM output Comparator_B input CB5 Analog input A5 – 12-bit ADC Output of reference voltage to the ADC Input for an external reference voltage to the ADC
P2.4/ PM_RTCCLK/ CB4/ A4/ VREF-/ VeREF-	47	I/O	General-purpose digital I/O with port interrupt and mappable secondary function Default mapping: RTCCLK output Comparator_B input CB4 Analog input A4 – 12-bit ADC Negative terminal for the ADC reference voltage for both sources, the internal reference voltage, or an external applied reference voltage
P2.3/ PM_TA1CCR2A/ CB3/ A3	48	I/O	General-purpose digital I/O with port interrupt and mappable secondary function Default mapping: TA1 CCR2 compare output or capture input Comparator_B input CB3 Analog input A3 – 12-bit ADC

Table 4-2. CC430F513x Terminal Functions (continued)

TERMINAL		I/O ⁽¹⁾	DESCRIPTION
NAME	NO.		
VSS, Exposed die attach pad			Ground supply The exposed die attach pad must be connected to a solid ground plane as this is the ground connection for the chip.

5 Specifications

All graphs in this section are for typical conditions, unless otherwise noted.

Typical (TYP) values are specified at $V_{CC} = 3.3\text{ V}$ and $T_A = 25^\circ\text{C}$, unless otherwise noted.

5.1 Absolute Maximum Ratings⁽¹⁾

over operating free-air temperature range (unless otherwise noted)

	MIN	MAX	UNIT
Voltage applied at DVCC and AVCC pins to V_{SS}	-0.3	4.1	V
Voltage applied to any pin (excluding V _{CORE} , RF_P, RF_N, and R_BIAS) ⁽²⁾	-0.3	$V_{CC} + 0.3$ (4.1 V Maximum)	V
Voltage applied to V _{CORE} , RF_P, RF_N, and R_BIAS ⁽²⁾	-0.3	2.0	V
Input RF level at pins RF_P and RF_N		10	dBm
Diode current at any device terminal		±2	mA
Storage temperature, T_{stg} ⁽³⁾	-55	150	°C
Maximum junction temperature, T_J		95	°C

- (1) Stresses beyond those listed under *Absolute Maximum Ratings* may cause permanent damage to the device. These are stress ratings only, and functional operation of the device at these or any other conditions beyond those indicated under *Recommended Operating Conditions* is not implied. Exposure to absolute-maximum-rated conditions for extended periods may affect device reliability.
- (2) All voltages referenced to V_{SS} .
- (3) Higher temperature may be applied during board soldering according to the current JEDEC J-STD-020 specification with peak reflow temperatures not higher than classified on the device label on the shipping boxes or reels.

5.2 ESD Ratings

	VALUE	UNIT
$V_{(ESD)}$ Electrostatic discharge	Human-body model (HBM), per ANSI/ESDA/JEDEC JS-001 ⁽¹⁾	±1000
	Charged-device model (CDM), per JEDEC specification JESD22-C101 ⁽²⁾	±250

- (1) JEDEC document JEP155 states that 500-V HBM allows safe manufacturing with a standard ESD control process. Pins listed as ±1000 V may actually have higher performance.
- (2) JEDEC document JEP157 states that 250-V CDM allows safe manufacturing with a standard ESD control process. Pins listed as ±250 V may actually have higher performance.

5.3 Recommended Operating Conditions

	MIN	NOM	MAX	UNIT		
V_{CC}	Supply voltage range applied at all DVCC and AVCC pins ⁽¹⁾ during program execution and flash programming with PMM default settings, Radio is not operational with PMMCOREVx = 0 or 1 ⁽²⁾⁽³⁾	PMMCOREVx = 0 (default after POR)	1.8	3.6	V	
		PMMCOREVx = 1	2.0	3.6		
		PMMCOREVx = 2	2.2	3.6		
		PMMCOREVx = 3	2.4	3.6		
	Supply voltage range applied at all DVCC and AVCC pins ⁽¹⁾ during program execution, flash programming and radio operation with PMM default settings ⁽²⁾⁽³⁾	PMMCOREVx = 2, SVSHRVLx = SVSHRRRLx = 1 or SVSHE = 0	2.0	3.6		
V_{SS}	Supply voltage applied at the exposed die attach VSS and AVSS pin			0	V	
T_A	Operating free-air temperature			-40	85	°C

- (1) TI recommends powering AVCC and DVCC from the same source. A maximum difference of 0.3 V between AVCC and DVCC can be tolerated during power up and operation.
- (2) Modules may have a different supply voltage range specification. See the specification of the respective module in this data sheet.
- (3) The minimum supply voltage is defined by the supervisor SVS levels when it is enabled. See the [Section 5.21](#) threshold parameters for the exact values and further details.
- (4) Lowering the high-side SVS level or disabling the high-side SVS might cause the LDO to operate out of regulation, but the core voltage will still stay within its limits and is still supervised by the low-side SVS, ensuring reliable operation.

Recommended Operating Conditions (continued)

		MIN	NOM	MAX	UNIT
T _J	Operating junction temperature	-40		85	°C
C _{VCORE}	Recommended capacitor at V _{CORE} ⁽⁵⁾		470		nF
C _{DVCC} / C _{VCORE}	Capacitor ratio of capacitor at DVCC to capacitor at V _{CORE}	10			
f _{SYSTEM}	Processor (MCLK) frequency ⁽⁶⁾ (see Figure 5-1)	PMMCOREV _x = 0 (default condition)	0	8	MHz
		PMMCOREV _x = 1	0	12	
		PMMCOREV _x = 2	0	16	
		PMMCOREV _x = 3	0	20	
P _{INT}	Internal power dissipation	$V_{CC} \times I_{DVCC}$			W
P _{IO}	I/O power dissipation of I/O pins powered by DVCC	$(V_{CC} - V_{IOH}) \times I_{IOH} + V_{IOL} \times I_{IOL}$			W
P _{MAX}	Maximum allowed power dissipation, P _{MAX} > P _{IO} + P _{INT}	$(T_J - T_A) / \theta_{JA}$			W

(5) A capacitor tolerance of ±20% or better is required.

(6) Modules may have a different maximum input clock specification. See the specification of the respective module in this data sheet.

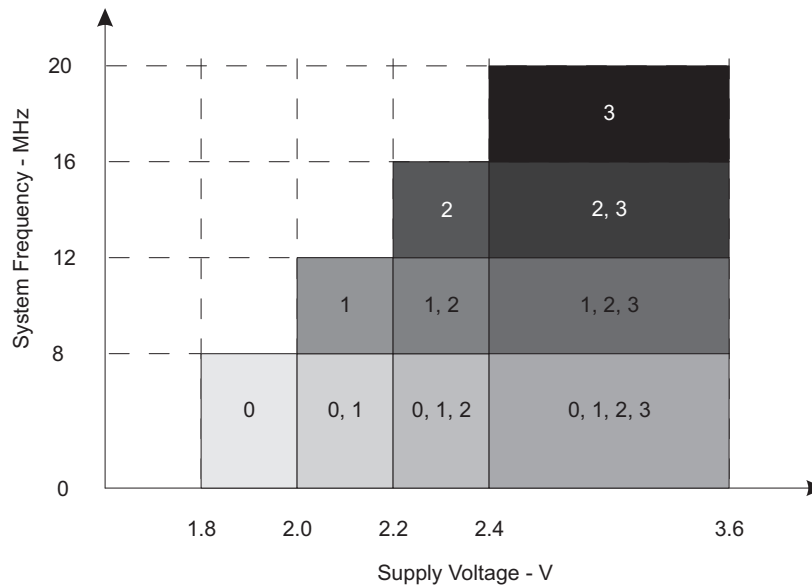

NOTE: The numbers within the fields are the supported PMMCOREV_x settings.

Figure 5-1. Maximum System Frequency

5.4 Active Mode Supply Current Into V_{CC} Excluding External Current

over recommended operating free-air temperature (unless otherwise noted)⁽¹⁾ ⁽²⁾ ⁽³⁾

PARAMETER	EXECUTION MEMORY	V _{CC}	PMMVCOREx	FREQUENCY (f _{DCO} = f _{MCLK} = f _{SMCLK})										UNIT
				1 MHz		8 MHz		12 MHz		16 MHz		20 MHz		
				TYP	MAX	TYP	MAX	TYP	MAX	TYP	MAX	TYP	MAX	
I _{AM, Flash} ⁽⁴⁾	Flash	3 V	0	0.23	0.26	1.35	1.60							mA
			1	0.25	0.28	1.55		2.30	2.65					
			2	0.27	0.30	1.75		2.60		3.45	3.90			
			3	0.28	0.32	1.85		2.75		3.65		4.55	5.10	
I _{AM, RAM} ⁽⁵⁾	RAM	3 V	0	0.18	0.20	0.95	1.10						mA	
			1	0.20	0.22	1.10		1.60	1.85					
			2	0.21	0.24	1.20		1.80		2.40	2.70			
			3	0.22	0.25	1.30		1.90		2.50		3.10		3.60

- (1) All inputs are tied to 0 V or to V_{CC}. Outputs do not source or sink any current.
- (2) The currents are characterized with a Micro Crystal MS1V-T1K crystal with a load capacitance of 12.5 pF. The internal and external load capacitance are chosen to closely match the required 12.5 pF.
- (3) Characterized with program executing typical data processing.
f_{ACLK} = 32786 Hz, f_{DCO} = f_{MCLK} = f_{SMCLK} at specified frequency.
XTS = CPUOFF = SCG0 = SCG1 = OSCOFF = SMCLKOFF = 0.
- (4) Active mode supply current when program executes in flash at a nominal supply voltage of 3 V.
- (5) Active mode supply current when program executes in RAM at a nominal supply voltage of 3 V.

5.5 Typical Characteristics – Active Mode Supply Currents

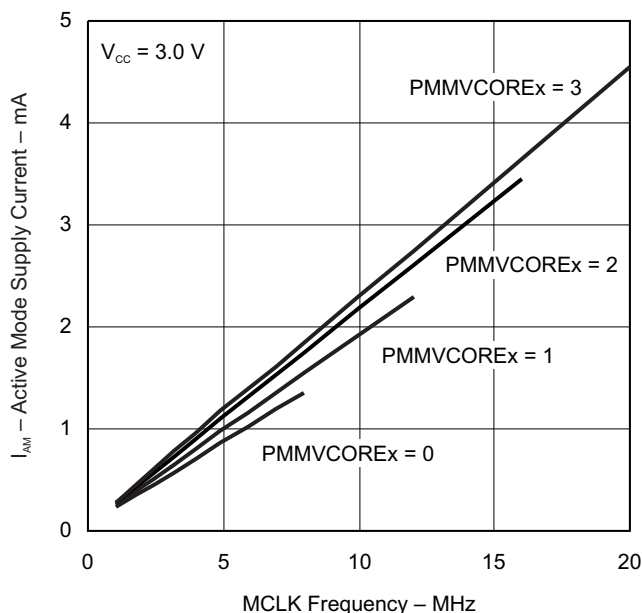

Figure 5-2. Active Mode Supply Current vs MCLK Frequency

5.6 Low-Power Mode Supply Currents (Into V_{CC}) Excluding External Current

over recommended ranges of supply voltage and operating free-air temperature (unless otherwise noted)^{(1) (2)}

PARAMETER	V_{CC}	PMMCOREVx	TEMPERATURE (T_A)								UNIT
			-40°C		25°C		60°C		85°C		
			TYP	MAX	TYP	MAX	TYP	MAX	TYP	MAX	
$I_{LPM0,1MHz}$ Low-power mode 0 ^{(3) (4)}	2.2 V	0	80	100	80	100	80	100	80	100	μA
	3 V	3	90	110	90	110	90	110	90	110	
I_{LPM2} Low-power mode 2 ^{(5) (4)}	2.2 V	0	6.5	11	6.5	11	6.5	11	6.5	11	μA
	3 V	3	7.5	12	7.5	12	7.5	12	7.5	12	
$I_{LPM3,XT1LF}$ Low-power mode 3, crystal mode ^{(6) (4)}	3 V	0	1.8		2.0	2.6	3.0	4.0	4.4	5.9	μA
		1	1.9		2.1		3.2		4.8		
		2	2.0		2.2		3.4		5.1		
		3	2.0	2.9	3.5	4.8	5.3	7.4			
$I_{LPM3,VLO}$ Low-power mode 3, VLO mode ^{(7) (4)}	3 V	0	0.9		1.1	2.3	2.1	3.7	3.5	5.6	μA
		1	1.0		1.2		2.3		3.9		
		2	1.1		1.3		2.5		4.2		
		3	1.1	2.6	2.6	4.5	4.4	7.1			
I_{LPM4} Low-power mode 4 ^{(8) (4)}	3 V	0	0.8		1.0	2.2	2.0	3.6	3.4	5.5	μA
		1	0.9		1.1		2.2		3.8		
		2	1.0		1.2		2.4		4.1		
		3	1.0	2.5	2.5	4.4	4.3	7.0			

- (1) All inputs are tied to 0 V or to V_{CC} . Outputs do not source or sink any current.
- (2) The currents are characterized with a Micro Crystal MS1V-T1K crystal with a load capacitance of 12.5 pF. The internal and external load capacitance are chosen to closely match the required 12.5 pF.
- (3) Current for watchdog timer clocked by SMCLK included. ACLK = low frequency crystal operation (XTS = 0, XT1DRIVEx = 0). CPUOFF = 1, SCG0 = 0, SCG1 = 0, OSCOFF = 0 (LPM0), f_{ACLK} = 32768 Hz, f_{MCLK} = 0 MHz, f_{SMCLK} = f_{DCO} = 1 MHz
- (4) Current for brownout, high-side supervisor (SVSH) normal mode included. Low-side supervisor (SVSL) and low-side monitor (SVM_L) disabled. High-side monitor (SVM_H) disabled. RAM retention enabled.
- (5) Current for watchdog timer and RTC clocked by ACLK included. ACLK = low frequency crystal operation (XTS = 0, XT1DRIVEx = 0). CPUOFF = 1, SCG0 = 0, SCG1 = 1, OSCOFF = 0 (LPM2), f_{ACLK} = 32768 Hz, f_{MCLK} = 0 MHz, f_{SMCLK} = f_{DCO} = 0 MHz, DCO setting = 1 MHz operation, DCO bias generator enabled.
- (6) Current for watchdog timer and RTC clocked by ACLK included. ACLK = low frequency crystal operation (XTS = 0, XT1DRIVEx = 0). CPUOFF = 1, SCG0 = 1, SCG1 = 1, OSCOFF = 0 (LPM3), f_{ACLK} = 32768 Hz, f_{MCLK} = f_{SMCLK} = f_{DCO} = 0 MHz
- (7) Current for watchdog timer and RTC clocked by ACLK included. ACLK = VLO. CPUOFF = 1, SCG0 = 1, SCG1 = 1, OSCOFF = 0 (LPM3), f_{ACLK} = f_{VLO} , f_{MCLK} = f_{SMCLK} = f_{DCO} = 0 MHz
- (8) CPUOFF = 1, SCG0 = 1, SCG1 = 1, OSCOFF = 1 (LPM4), f_{DCO} = f_{ACLK} = f_{MCLK} = f_{SMCLK} = 0 MHz

5.7 Typical Characteristics – Low-Power Mode Supply Currents

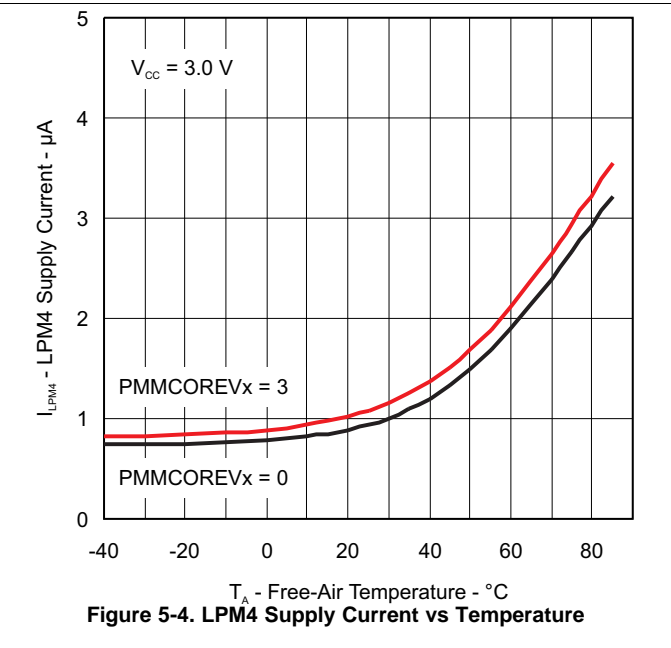
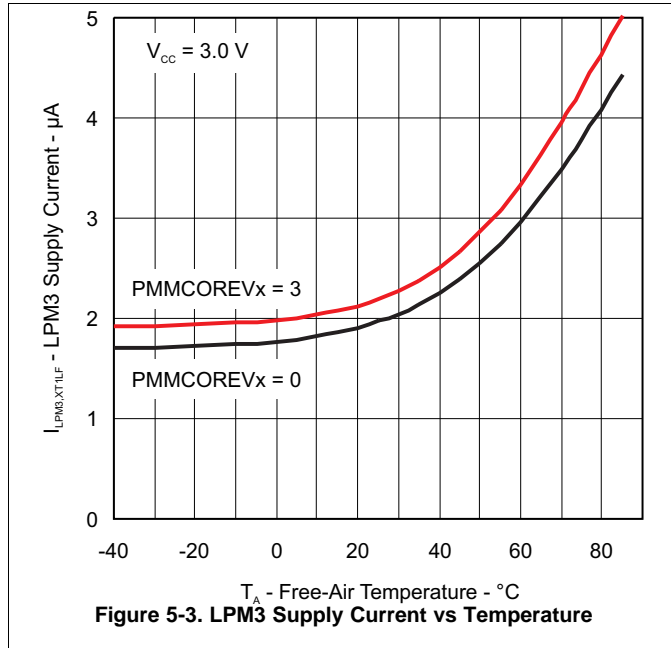

5.8 Low-Power Mode With LCD Supply Currents (Into V_{CC}) Excluding External Current

over recommended ranges of supply voltage and operating free-air temperature (unless otherwise noted)^{(1) (2)}

PARAMETER	V_{CC}	PMMCOREVx	TEMPERATURE (T_A)								UNIT
			-40°C		25°C		60°C		85°C		
			TYP	MAX	TYP	MAX	TYP	MAX	TYP	MAX	
I_{LPM3} LCD, ext. bias	3 V	0	2.2		2.4		3.5		4.9	μ A	
		1	2.3		2.5		3.7		5.3		
		2	2.4		2.6		3.9		5.6		
		3	2.4		2.6		4.0		5.8		
I_{LPM3} LCD, int. bias	3 V	0	3.1		3.3	4.0	4.3		5.8	7.4	μ A
		1	3.2		3.4		4.5		6.2		
		2	3.3		3.5		4.7		6.5		
		3	3.3		3.5	4.3	4.8		6.7	8.9	
I_{LPM3} LCD,CP	2.2 V	0			4.0						μ A
		1			4.1						
		2			4.2						
	3 V	0			4.2						
		1			4.3						
		2			4.5						
		3			4.5						

- All inputs are tied to 0 V or to V_{CC} . Outputs do not source or sink any current.
- The currents are characterized with a Micro Crystal MS1V-T1K crystal with a load capacitance of 12.5 pF. The internal and external load capacitance are chosen to closely match the required 12.5 pF.
- Current for watchdog timer and RTC clocked by ACLK included. ACLK = low frequency crystal operation (XTS = 0, XT1DRIVEx = 0). CPUOFF = 1, SCG0 = 1, SCG1 = 1, OSCOFF = 0 (LPM3), f_{ACLK} = 32768 Hz, f_{MCLK} = f_{SMCLK} = f_{DCO} = 0 MHz. Current for brownout, high-side supervisor (SVSH) normal mode included. Low-side supervisor (SVSL) and low-side monitor (SVM_L) disabled. High-side monitor (SVM_H) disabled. RAM retention enabled.
- LCDMx = 11 (4-mux mode), LCDREXT = 1, LCDEXTBIAS = 1 (external biasing), LCD2B = 0 (1/3 bias), LCDCPEN = 0 (charge pump disabled), LCDSSEL = 0, LCDPREx = 101, LCDDIVx = 00011 (f_{LCD} = 32768 Hz / 32 / 4 = 256 Hz). Current through external resistors not included (voltage levels are supplied by test equipment). Even segments S0, S2,... = 0, odd segments S1, S3,... = 1. No LCD panel load.
- LCDMx = 11 (4-mux mode), LCDREXT = 0, LCDEXTBIAS = 0 (internal biasing), LCD2B = 0 (1/3 bias), LCDCPEN = 0 (charge pump disabled), LCDSSEL = 0, LCDPREx = 101, LCDDIVx = 00011 (f_{LCD} = 32768 Hz / 32 / 4 = 256 Hz). Even segments S0, S2,... = 0, odd segments S1, S3,... = 1. No LCD panel load.
- LCDMx = 11 (4-mux mode), LCDREXT = 0, LCDEXTBIAS = 0 (internal biasing), LCD2B = 0 (1/3 bias), LCDCPEN = 1 (charge pump enabled), VLCDx = 1000 (V_{LCD} = 3 V, typical), LCDSSEL = 0, LCDPREx = 101, LCDDIVx = 00011 (f_{LCD} = 32768 Hz / 32 / 4 = 256 Hz). Even segments S0, S2,... = 0, odd segments S1, S3,... = 1. No LCD panel load.

5.9 Thermal Resistance Characteristics, CC430F51xx

		PACKAGE	VALUE
θ_{JA}	Junction-to-ambient thermal resistance, still air	Low-K board	98°C/W
		High-K board	28°C/W

5.10 Thermal Resistance Characteristics, CC430F61xx

		PACKAGE	VALUE
θ_{JA}	Junction-to-ambient thermal resistance, still air	Low-K board	83°C/W
		High-K board	26°C/W

5.11 Digital Inputs

over recommended ranges of supply voltage and operating free-air temperature (unless otherwise noted)

PARAMETER		TEST CONDITIONS	V _{CC}	MIN	TYP	MAX	UNIT
V _{IT+}	Positive-going input threshold voltage		1.8 V	0.80		1.40	V
			3 V	1.50		2.10	
V _{IT-}	Negative-going input threshold voltage		1.8 V	0.45		1.00	V
			3 V	0.75		1.65	
V _{hys}	Input voltage hysteresis (V _{IT+} – V _{IT-})		1.8 V	0.3		0.8	V
			3 V	0.4		1.0	
R _{Pull}	Pullup or pulldown resistor	For pullup: V _{IN} = V _{SS} For pulldown: V _{IN} = V _{CC}		20	35	50	kΩ
C _I	Input capacitance	V _{IN} = V _{SS} or V _{CC}			5		pF
I _{lkg(Px.y)}	High-impedance leakage current	See ⁽¹⁾ ⁽²⁾	1.8 V, 3 V			±50	nA
t _(int)	External interrupt timing (external trigger pulse duration to set interrupt flag) ⁽³⁾	Ports with interrupt capability [see block diagram (§ 1.4) and terminal function descriptions (Section 4.2)]	1.8 V, 3 V	20			ns

(1) The leakage current is measured with V_{SS} or V_{CC} applied to the corresponding pins, unless otherwise noted.

(2) The leakage of the digital port pins is measured individually. The port pin is selected for input and the pullup or pulldown resistor is disabled.

(3) An external signal sets the interrupt flag every time the minimum interrupt pulse duration t_(int) is met. It may be set by trigger signals shorter than t_(int).

5.12 Digital Outputs

over recommended ranges of supply voltage and operating free-air temperature (unless otherwise noted)

PARAMETER		TEST CONDITIONS	V _{CC}	MIN	MAX	UNIT
V _{OH}	High-level output voltage, reduced drive strength ⁽¹⁾	I _(OHmax) = -1 mA, PxDS.y = 0 ⁽²⁾	1.8 V	V _{CC} - 0.25	V _{CC}	V
		I _(OHmax) = -3 mA, PxDS.y = 0 ⁽³⁾		V _{CC} - 0.60	V _{CC}	
		I _(OHmax) = -2 mA, PxDS.y = 0 ⁽²⁾	3 V	V _{CC} - 0.25	V _{CC}	
		I _(OHmax) = -6 mA, PxDS.y = 0 ⁽³⁾		V _{CC} - 0.60	V _{CC}	
V _{OL}	Low-level output voltage, reduced drive strength ⁽¹⁾	I _(OLmax) = 1 mA, PxDS.y = 0 ⁽²⁾	1.8 V	V _{SS}	V _{SS} + 0.25	V
		I _(OLmax) = 3 mA, PxDS.y = 0 ⁽³⁾		V _{SS}	V _{SS} + 0.60	
		I _(OLmax) = 2 mA, PxDS.y = 0 ⁽²⁾	3 V	V _{SS}	V _{SS} + 0.25	
		I _(OLmax) = 6 mA, PxDS.y = 0 ⁽³⁾		V _{SS}	V _{SS} + 0.60	
V _{OH}	High-level output voltage, full drive strength	I _(OHmax) = -3 mA, PxDS.y = 1 ⁽²⁾	1.8 V	V _{CC} - 0.25	V _{CC}	V
		I _(OHmax) = -10 mA, PxDS.y = 1 ⁽³⁾		V _{CC} - 0.60	V _{CC}	
		I _(OHmax) = -5 mA, PxDS.y = 1 ⁽²⁾	3 V	V _{CC} - 0.25	V _{CC}	
		I _(OHmax) = -15 mA, PxDS.y = 1 ⁽³⁾		V _{CC} - 0.60	V _{CC}	
V _{OL}	Low-level output voltage, full drive strength	I _(OLmax) = 3 mA, PxDS.y = 1 ⁽²⁾	1.8 V	V _{SS}	V _{SS} + 0.25	V
		I _(OLmax) = 10 mA, PxDS.y = 1 ⁽³⁾		V _{SS}	V _{SS} + 0.60	
		I _(OLmax) = 5 mA, PxDS.y = 1 ⁽²⁾	3 V	V _{SS}	V _{SS} + 0.25	
		I _(OLmax) = 15 mA, PxDS.y = 1 ⁽³⁾		V _{SS}	V _{SS} + 0.60	
f _{Px.y}	Port output frequency (with load)	C _L = 20 pF, R _L ⁽⁴⁾ ⁽⁵⁾	V _{CC} = 1.8 V, PMMCOREVx = 0		16	MHz
			V _{CC} = 3 V, PMMCOREVx = 2		25	
f _{Port_CLK}	Clock output frequency	C _L = 20 pF ⁽⁵⁾	V _{CC} = 1.8 V, PMMCOREVx = 0		16	MHz
			V _{CC} = 3 V, PMMCOREVx = 2		25	

- (1) Selecting reduced drive strength may reduce EMI.
- (2) The maximum total current, I_(OHmax) and I_(OLmax), for all outputs combined should not exceed ±48 mA to hold the maximum voltage drop specified.
- (3) The maximum total current, I_(OHmax) and I_(OLmax), for all outputs combined should not exceed ±100 mA to hold the maximum voltage drop specified.
- (4) A resistive divider with 2 × R1 between V_{CC} and V_{SS} is used as load. The output is connected to the center tap of the divider. For full drive strength, R1 = 550 Ω. For reduced drive strength, R1 = 1.6 kΩ. C_L = 20 pF is connected to the output to V_{SS}.
- (5) The output voltage reaches at least 10% and 90% V_{CC} at the specified toggle frequency.

5.13 Typical Characteristics – Outputs, Reduced Drive Strength (PxDS.y = 0)

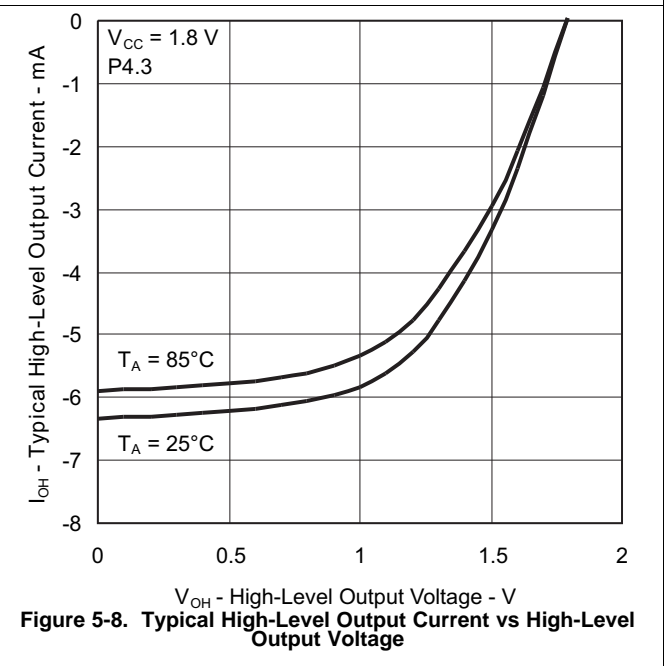
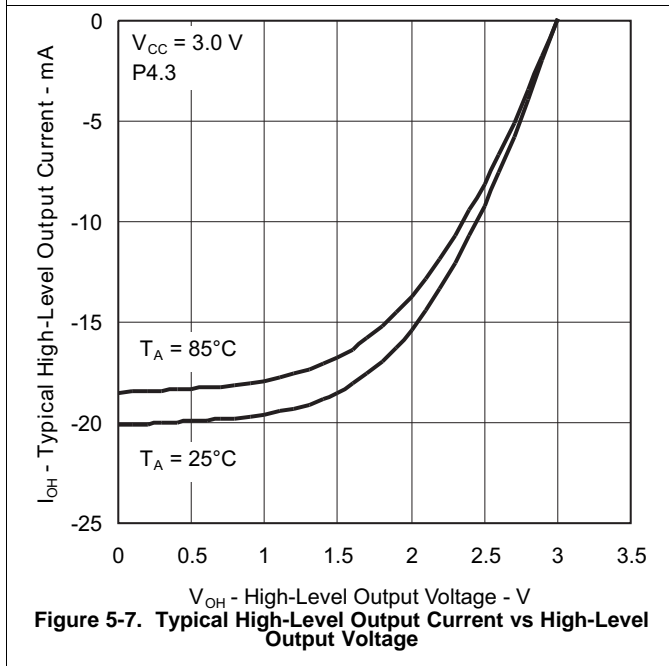
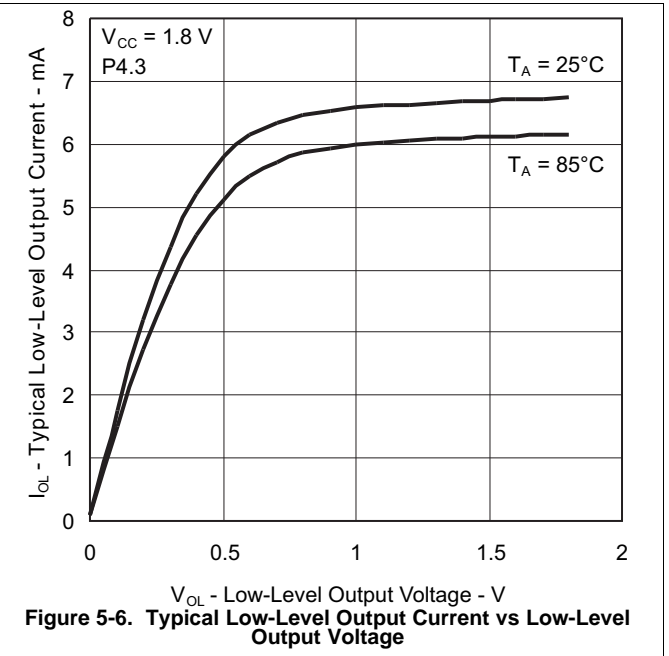
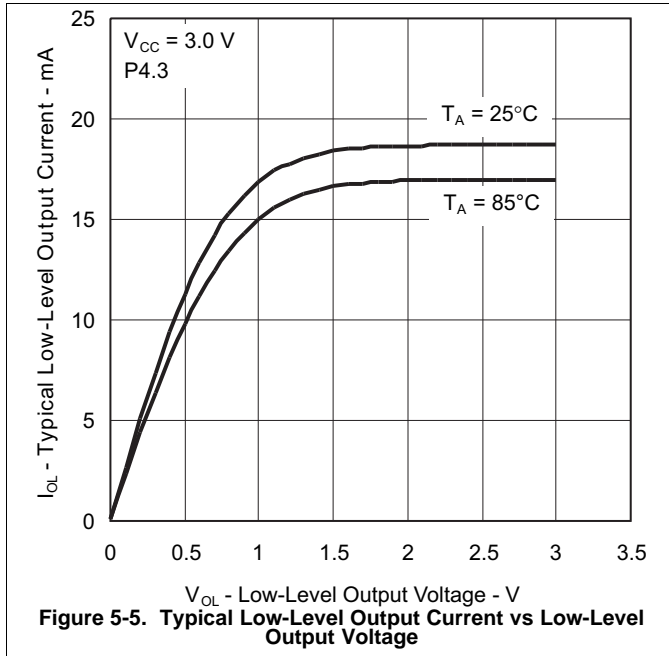

5.14 Typical Characteristics – Outputs, Full Drive Strength (PxDS.y = 1)

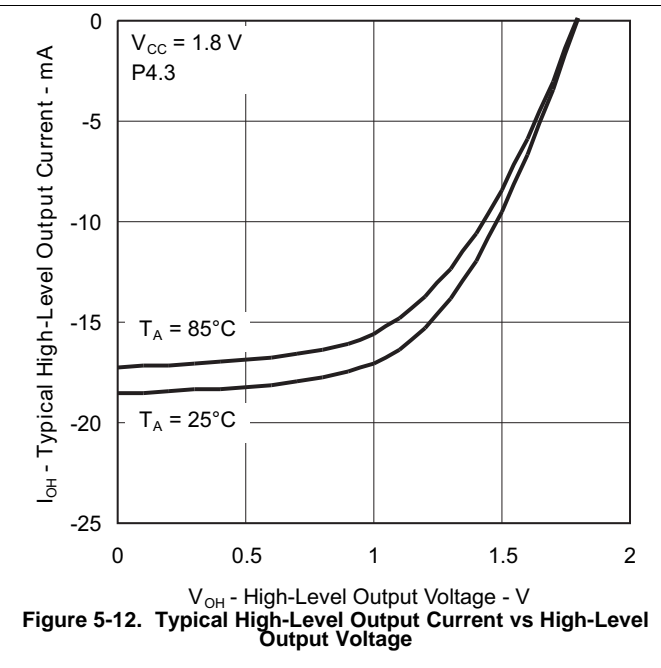
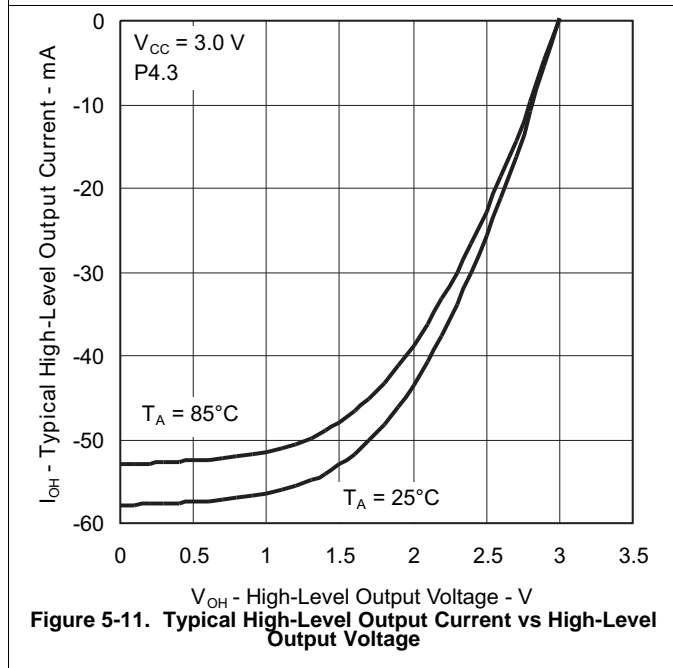
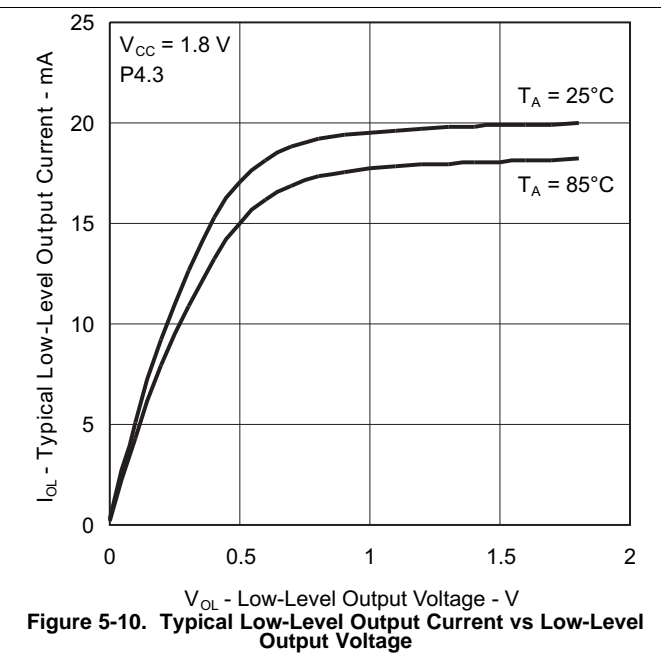
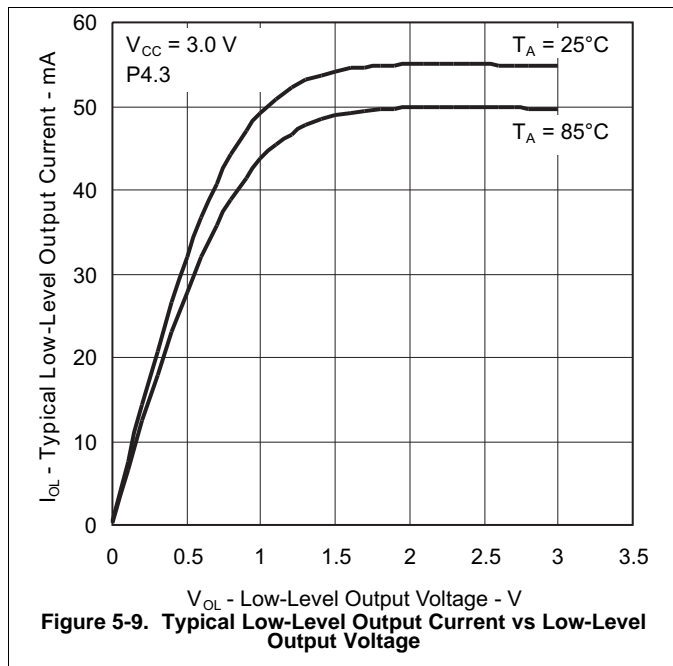

5.15 Crystal Oscillator, XT1, Low-Frequency Mode⁽¹⁾

over recommended ranges of supply voltage and operating free-air temperature (unless otherwise noted)

PARAMETER		TEST CONDITIONS	V _{CC}	MIN	TYP	MAX	UNIT
$\Delta I_{DVCC,LF}$	Differential XT1 oscillator crystal current consumption from lowest drive setting, LF mode	$f_{OSC} = 32768$ Hz, XTS = 0, XT1BYPASS = 0, XT1DRIVE _x = 1, T _A = 25°C	3 V	0.075		μ A	
		$f_{OSC} = 32768$ Hz, XTS = 0, XT1BYPASS = 0, XT1DRIVE _x = 2, T _A = 25°C		0.170			
		$f_{OSC} = 32768$ Hz, XTS = 0, XT1BYPASS = 0, XT1DRIVE _x = 3, T _A = 25°C		0.290			
$f_{XT1,LF0}$	XT1 oscillator crystal frequency, LF mode	XTS = 0, XT1BYPASS = 0		32768		Hz	
$f_{XT1,LF,SW}$	XT1 oscillator logic-level square-wave input frequency, LF mode	XTS = 0, XT1BYPASS = 1 ⁽²⁾ ⁽³⁾		10	32.768	50	kHz
OA_{LF}	Oscillation allowance for LF crystals ⁽⁴⁾	XTS = 0, XT1BYPASS = 0, XT1DRIVE _x = 0, $f_{XT1,LF} = 32768$ Hz, C _{L,eff} = 6 pF		210		k Ω	
		XTS = 0, XT1BYPASS = 0, XT1DRIVE _x = 1, $f_{XT1,LF} = 32768$ Hz, C _{L,eff} = 12 pF		300			
$C_{L,eff}$	Integrated effective load capacitance, LF mode ⁽⁵⁾	XTS = 0, XCAP _x = 0 ⁽⁶⁾		2		pF	
		XTS = 0, XCAP _x = 1		5.5			
		XTS = 0, XCAP _x = 2		8.5			
		XTS = 0, XCAP _x = 3		12.0			
	Duty cycle, LF mode	XTS = 0, Measured at ACLK, $f_{XT1,LF} = 32768$ Hz		30%		70%	
$f_{Fault,LF}$	Oscillator fault frequency, LF mode ⁽⁷⁾	XTS = 0 ⁽⁸⁾		10		10000	Hz
$t_{START,LF}$	Start-up time, LF mode	$f_{OSC} = 32768$ Hz, XTS = 0, XT1BYPASS = 0, XT1DRIVE _x = 0, T _A = 25°C, C _{L,eff} = 6 pF	3 V	1000		ms	
		$f_{OSC} = 32768$ Hz, XTS = 0, XT1BYPASS = 0, XT1DRIVE _x = 3, T _A = 25°C, C _{L,eff} = 12 pF		500			

- (1) To improve EMI on the XT1 oscillator, the following guidelines should be observed.
 - Keep the trace between the device and the crystal as short as possible.
 - Design a good ground plane around the oscillator pins.
 - Prevent crosstalk from other clock or data lines into oscillator pins XIN and XOUT.
 - Avoid running PCB traces underneath or adjacent to the XIN and XOUT pins.
 - Use assembly materials and processes that avoid any parasitic load on the oscillator XIN and XOUT pins.
 - If conformal coating is used, make sure that it does not induce capacitive or resistive leakage between the oscillator pins.
- (2) When XT1BYPASS is set, XT1 circuits are automatically powered down. Input signal is a digital square wave with parametrics defined in the Schmitt-trigger Inputs section of this datasheet.
- (3) Maximum frequency of operation of the entire device cannot be exceeded.
- (4) Oscillation allowance is based on a safety factor of 5 for recommended crystals. The oscillation allowance is a function of the XT1DRIVE_x settings and the effective load. In general, comparable oscillator allowance can be achieved based on the following guidelines, but should be evaluated based on the actual crystal selected for the application:
 - For XT1DRIVE_x = 0, C_{L,eff} ≤ 6 pF
 - For XT1DRIVE_x = 1, 6 pF ≤ C_{L,eff} ≤ 9 pF
 - For XT1DRIVE_x = 2, 6 pF ≤ C_{L,eff} ≤ 10 pF
 - For XT1DRIVE_x = 3, C_{L,eff} ≥ 6 pF
- (5) Includes parasitic bond and package capacitance (approximately 2 pF per pin). Because the PCB adds additional capacitance, verify the correct load by measuring the ACLK frequency. For a correct setup, the effective load capacitance should always match the specification of the used crystal.
- (6) Requires external capacitors at both terminals. Values are specified by crystal manufacturers.
- (7) Frequencies below the MIN specification set the fault flag. Frequencies above the MAX specification do not set the fault flag. Frequencies between the MIN and MAX specifications might set the flag.
- (8) Measured with logic-level input frequency but also applies to operation with crystals.

5.16 Internal Very-Low-Power Low-Frequency Oscillator (VLO)

over recommended ranges of supply voltage and operating free-air temperature (unless otherwise noted)

PARAMETER		TEST CONDITIONS	V _{CC}	MIN	TYP	MAX	UNIT
f _{VLO}	VLO frequency	Measured at ACLK	1.8 V to 3.6 V	6	9.4	14	kHz
df _{VLO} /dT	VLO frequency temperature drift	Measured at ACLK ⁽¹⁾	1.8 V to 3.6 V		0.5		%/°C
df _{VLO} /dV _{CC}	VLO frequency supply voltage drift	Measured at ACLK ⁽²⁾	1.8 V to 3.6 V		4		%/V
	Duty cycle	Measured at ACLK	1.8 V to 3.6 V	40%	50%	60%	

(1) Calculated using the box method: (MAX(−40°C to 85°C) – MIN(−40°C to 85°C)) / MIN(−40°C to 85°C) / (85°C – (−40°C))

(2) Calculated using the box method: (MAX(1.8 V to 3.6 V) – MIN(1.8 V to 3.6 V)) / MIN(1.8 V to 3.6 V) / (3.6 V – 1.8 V)

5.17 Internal Reference, Low-Frequency Oscillator (REFO)

over recommended ranges of supply voltage and operating free-air temperature (unless otherwise noted)

PARAMETER		TEST CONDITIONS	V _{CC}	MIN	TYP	MAX	UNIT
I _{REFO}	REFO oscillator current consumption	T _A = 25°C	1.8 V to 3.6 V		3		μA
f _{REFO}	REFO frequency calibrated	Measured at ACLK	1.8 V to 3.6 V		32768		Hz
	REFO absolute tolerance calibrated	Full temperature range	1.8 V to 3.6 V			±3.5%	
		T _A = 25°C	3 V			±1.5%	
df _{REFO} /dT	REFO frequency temperature drift	Measured at ACLK ⁽¹⁾	1.8 V to 3.6 V		0.01		%/°C
df _{REFO} /dV _C	REFO frequency supply voltage drift	Measured at ACLK ⁽²⁾	1.8 V to 3.6 V		1.0		%/V
	Duty cycle	Measured at ACLK	1.8 V to 3.6 V	40%	50%	60%	
t _{START}	REFO start-up time	40%/60% duty cycle	1.8 V to 3.6 V		25		μs

(1) Calculated using the box method: (MAX(−40°C to 85°C) – MIN(−40°C to 85°C)) / MIN(−40°C to 85°C) / (85°C – (−40°C))

(2) Calculated using the box method: (MAX(1.8 V to 3.6 V) – MIN(1.8 V to 3.6 V)) / MIN(1.8 V to 3.6 V) / (3.6 V – 1.8 V)

5.18 DCO Frequency

over recommended ranges of supply voltage and operating free-air temperature (unless otherwise noted)

PARAMETER		TEST CONDITIONS	MIN	TYP	MAX	UNIT
f _{DCO(0,0)}	DCO frequency (0, 0) ⁽¹⁾	DCORSELx = 0, DCOx = 0, MODx = 0	0.07		0.20	MHz
f _{DCO(0,31)}	DCO frequency (0, 31) ⁽¹⁾	DCORSELx = 0, DCOx = 31, MODx = 0	0.70		1.70	MHz
f _{DCO(1,0)}	DCO frequency (1, 0) ⁽¹⁾	DCORSELx = 1, DCOx = 0, MODx = 0	0.15		0.36	MHz
f _{DCO(1,31)}	DCO frequency (1, 31) ⁽¹⁾	DCORSELx = 1, DCOx = 31, MODx = 0	1.47		3.45	MHz
f _{DCO(2,0)}	DCO frequency (2, 0) ⁽¹⁾	DCORSELx = 2, DCOx = 0, MODx = 0	0.32		0.75	MHz
f _{DCO(2,31)}	DCO frequency (2, 31) ⁽¹⁾	DCORSELx = 2, DCOx = 31, MODx = 0	3.17		7.38	MHz
f _{DCO(3,0)}	DCO frequency (3, 0) ⁽¹⁾	DCORSELx = 3, DCOx = 0, MODx = 0	0.64		1.51	MHz
f _{DCO(3,31)}	DCO frequency (3, 31) ⁽¹⁾	DCORSELx = 3, DCOx = 31, MODx = 0	6.07		14.0	MHz
f _{DCO(4,0)}	DCO frequency (4, 0) ⁽¹⁾	DCORSELx = 4, DCOx = 0, MODx = 0	1.3		3.2	MHz
f _{DCO(4,31)}	DCO frequency (4, 31) ⁽¹⁾	DCORSELx = 4, DCOx = 31, MODx = 0	12.3		28.2	MHz
f _{DCO(5,0)}	DCO frequency (5, 0) ⁽¹⁾	DCORSELx = 5, DCOx = 0, MODx = 0	2.5		6.0	MHz
f _{DCO(5,31)}	DCO frequency (5, 31) ⁽¹⁾	DCORSELx = 5, DCOx = 31, MODx = 0	23.7		54.1	MHz
f _{DCO(6,0)}	DCO frequency (6, 0) ⁽¹⁾	DCORSELx = 6, DCOx = 0, MODx = 0	4.6		10.7	MHz
f _{DCO(6,31)}	DCO frequency (6, 31) ⁽¹⁾	DCORSELx = 6, DCOx = 31, MODx = 0	39.0		88.0	MHz
f _{DCO(7,0)}	DCO frequency (7, 0) ⁽¹⁾	DCORSELx = 7, DCOx = 0, MODx = 0	8.5		19.6	MHz
f _{DCO(7,31)}	DCO frequency (7, 31) ⁽¹⁾	DCORSELx = 7, DCOx = 31, MODx = 0	60		135	MHz
S _{DCORSEL}	Frequency step between range DCORSEL and DCORSEL + 1	S _{RSEL} = f _{DCO(DCORSEL+1,DCO)} /f _{DCO(DCORSEL,DCO)}	1.2		2.3	ratio

(1) When selecting the proper DCO frequency range (DCORSELx), the target DCO frequency, f_{DCO}, should be set to reside within the range of f_{DCO(n, 0),MAX} ≤ f_{DCO} ≤ f_{DCO(n, 31),MIN}, where f_{DCO(n, 0),MAX} represents the maximum frequency specified for the DCO frequency, range n, tap 0 (DCOx = 0) and f_{DCO(n,31),MIN} represents the minimum frequency specified for the DCO frequency, range n, tap 31 (DCOx = 31). This ensures that the target DCO frequency resides within the range selected. It should also be noted that if the actual f_{DCO} frequency for the selected range causes the FLL or the application to select tap 0 or 31, the DCO fault flag is set to report that the selected range is at its minimum or maximum tap setting.

DCO Frequency (continued)

over recommended ranges of supply voltage and operating free-air temperature (unless otherwise noted)

PARAMETER		TEST CONDITIONS	MIN	TYP	MAX	UNIT
S _{DCO}	Frequency step between tap DCO and DCO + 1	$S_{DCO} = f_{DCO(DCORSEL,DCO+1)} / f_{DCO(DCORSEL,DCO)}$	1.02		1.12	ratio
	Duty cycle	Measured at SMCLK	40%	50%	60%	
df _{DCO} /dT	DCO frequency temperature drift	f _{DCO} = 1 MHz		0.1		%/°C
df _{DCO} /dV _{CC}	DCO frequency voltage drift	f _{DCO} = 1 MHz		1.9		%/V

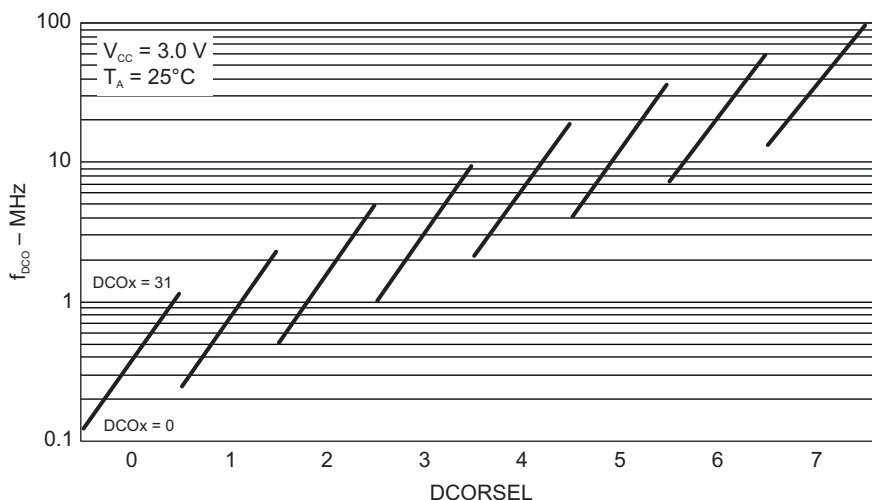

Figure 5-13. Typical DCO Frequency

5.19 PMM, Brownout Reset (BOR)

over recommended ranges of supply voltage and operating free-air temperature (unless otherwise noted)

PARAMETER		TEST CONDITIONS	MIN	TYP	MAX	UNIT
V _(DVCC_BOR_IT-)	BOR _H on voltage, DV _{CC} falling level	dDV _{CC} /dt < 3 V/s			1.45	V
V _(DVCC_BOR_IT+)	BOR _H off voltage, DV _{CC} rising level	dDV _{CC} /dt < 3 V/s	0.80	1.30	1.50	V
V _(DVCC_BOR_hys)	BOR _H hysteresis		50		250	mV
t _{RESET}	Pulse duration required at RST/NMI pin to accept a reset		2			μs

5.20 PMM, Core Voltage

over recommended ranges of supply voltage and operating free-air temperature (unless otherwise noted)

PARAMETER		TEST CONDITIONS	MIN	TYP	MAX	UNIT
V _{CORE3(AM)}	Core voltage, active mode, PMMCOREV = 3	2.4 V ≤ DV _{CC} ≤ 3.6 V		1.90		V
V _{CORE2(AM)}	Core voltage, active mode, PMMCOREV = 2	2.2 V ≤ DV _{CC} ≤ 3.6 V		1.80		V
V _{CORE1(AM)}	Core voltage, active mode, PMMCOREV = 1	2 V ≤ DV _{CC} ≤ 3.6 V		1.60		V
V _{CORE0(AM)}	Core voltage, active mode, PMMCOREV = 0	1.8 V ≤ DV _{CC} ≤ 3.6 V		1.40		V
V _{CORE3(LPM)}	Core voltage, low-current mode, PMMCOREV = 3	2.4 V ≤ DV _{CC} ≤ 3.6 V		1.94		V
V _{CORE2(LPM)}	Core voltage, low-current mode, PMMCOREV = 2	2.2 V ≤ DV _{CC} ≤ 3.6 V		1.84		V
V _{CORE1(LPM)}	Core voltage, low-current mode, PMMCOREV = 1	2 V ≤ DV _{CC} ≤ 3.6 V		1.64		V
V _{CORE0(LPM)}	Core voltage, low-current mode, PMMCOREV = 0	1.8 V ≤ DV _{CC} ≤ 3.6 V		1.44		V

5.21 PMM, SVS High Side

over recommended ranges of supply voltage and operating free-air temperature (unless otherwise noted)

PARAMETER		TEST CONDITIONS	MIN	TYP	MAX	UNIT
$I_{(SVSH)}$	SVS current consumption	SVSHE = 0, DV _{CC} = 3.6 V		0		nA
		SVSHE = 1, DV _{CC} = 3.6 V, SVSHFP = 0		200		
		SVSHE = 1, DV _{CC} = 3.6 V, SVSHFP = 1		1.5		μA
$V_{(SVSH_IT-)}$	SVS _H on voltage level ⁽¹⁾	SVSHE = 1, SVSHRVL = 0	1.53	1.60	1.67	V
		SVSHE = 1, SVSHRVL = 1	1.73	1.80	1.87	
		SVSHE = 1, SVSHRVL = 2	1.93	2.00	2.07	
		SVSHE = 1, SVSHRVL = 3	2.03	2.10	2.17	
$V_{(SVSH_IT+)}$	SVS _H off voltage level ⁽¹⁾	SVSHE = 1, SVSMHRRRL = 0	1.60	1.70	1.80	V
		SVSHE = 1, SVSMHRRRL = 1	1.80	1.90	2.00	
		SVSHE = 1, SVSMHRRRL = 2	2.00	2.10	2.20	
		SVSHE = 1, SVSMHRRRL = 3	2.10	2.20	2.30	
		SVSHE = 1, SVSMHRRRL = 4	2.25	2.35	2.50	
		SVSHE = 1, SVSMHRRRL = 5	2.52	2.65	2.78	
		SVSHE = 1, SVSMHRRRL = 6	2.85	3.00	3.15	
		SVSHE = 1, SVSMHRRRL = 7	2.85	3.00	3.15	
$t_{pd(SVSH)}$	SVS _H propagation delay	SVSHE = 1, dV _{DVCC} /dt = 10 mV/μs, SVSHFP = 1		2.5		μs
		SVSHE = 1, dV _{DVCC} /dt = 1 mV/μs, SVSHFP = 0		20		
$t_{(SVSH)}$	SVS _H on or off delay time	SVSHE = 0 → 1, dV _{DVCC} /dt = 10 mV/μs, SVSHFP = 1		12.5		μs
		SVSHE = 0 → 1, dV _{DVCC} /dt = 1 mV/μs, SVSHFP = 0		100		
dV _{DVCC} /dt	DV _{CC} rise time		0		1000	V/s

(1) The SVS_H settings available depend on the VCORE (PMMCOREVx) setting. See the *Power Management Module and Supply Voltage Supervisor* chapter in the [CC430 Family User's Guide](#) on recommended settings and use.

5.22 PMM, SVM High Side

over recommended ranges of supply voltage and operating free-air temperature (unless otherwise noted)

PARAMETER		TEST CONDITIONS	MIN	TYP	MAX	UNIT
$I_{(SVMH)}$	SVM _H current consumption	SVMHE = 0, DV _{CC} = 3.6 V		0		nA
		SVMHE = 1, DV _{CC} = 3.6 V, SVMHFP = 0		200		
		SVMHE = 1, DV _{CC} = 3.6 V, SVMHFP = 1		1.5		μA
$V_{(SVMH)}$	SVM _H on or off voltage level ⁽¹⁾	SVMHE = 1, SVMHRRRL = 0	1.60	1.70	1.80	V
		SVMHE = 1, SVMHRRRL = 1	1.80	1.90	2.00	
		SVMHE = 1, SVMHRRRL = 2	2.00	2.10	2.20	
		SVMHE = 1, SVMHRRRL = 3	2.10	2.20	2.30	
		SVMHE = 1, SVMHRRRL = 4	2.25	2.35	2.50	
		SVMHE = 1, SVMHRRRL = 5	2.52	2.65	2.78	
		SVMHE = 1, SVMHRRRL = 6	2.85	3.00	3.15	
		SVMHE = 1, SVMHRRRL = 7	2.85	3.00	3.15	
		SVMHE = 1, SVMHOVPE = 1		3.75		
$t_{pd(SVMH)}$	SVM _H propagation delay	SVMHE = 1, dV _{DVCC} /dt = 10 mV/μs, SVMHFP = 1		2.5		μs
		SVMHE = 1, dV _{DVCC} /dt = 1 mV/μs, SVMHFP = 0		20		
$t_{(SVMH)}$	SVM _H on or off delay time	SVMHE = 0 → 1, dV _{DVCC} /dt = 10 mV/μs, SVMHFP = 1		12.5		μs
		SVMHE = 0 → 1, dV _{DVCC} /dt = 1 mV/μs, SVMHFP = 0		100		

(1) The SVM_H settings available depend on the VCORE (PMMCOREVx) setting. See the *Power Management Module and Supply Voltage Supervisor* chapter in the [CC430 Family User's Guide](#) on recommended settings and use.

5.23 PMM, SVS Low Side

over recommended ranges of supply voltage and operating free-air temperature (unless otherwise noted)

PARAMETER		TEST CONDITIONS	MIN	TYP	MAX	UNIT
$I_{(SVSL)}$	SVS _L current consumption	SVSLE = 0, PMMCOREV = 2		0		nA
		SVSLE = 1, PMMCOREV = 2, SVSLFP = 0		200		nA
		SVSLE = 1, PMMCOREV = 2, SVSLFP = 1		1.5		μA
$t_{pd(SVSL)}$	SVS _L propagation delay	SVSLE = 1, $dV_{CORE}/dt = 10 \text{ mV}/\mu\text{s}$, SVSLFP = 1		2.5		μs
		SVSLE = 1, $dV_{CORE}/dt = 1 \text{ mV}/\mu\text{s}$, SVSLFP = 0		20		
$t_{(SVSL)}$	SVS _L on or off delay time	SVSLE = 0 → 1, $dV_{CORE}/dt = 10 \text{ mV}/\mu\text{s}$, SVSLFP = 1		12.5		μs
		SVSLE = 0 → 1, $dV_{CORE}/dt = 1 \text{ mV}/\mu\text{s}$, SVSLFP = 0		100		

5.24 PMM, SVM Low Side

over recommended ranges of supply voltage and operating free-air temperature (unless otherwise noted)

PARAMETER		TEST CONDITIONS	MIN	TYP	MAX	UNIT
$I_{(SVM_L)}$	SVM _L current consumption	SVMLE = 0, PMMCOREV = 2		0		nA
		SVMLE = 1, PMMCOREV = 2, SVM_LFP = 0		200		nA
		SVMLE = 1, PMMCOREV = 2, SVM_LFP = 1		1.5		μA
$t_{pd(SVM_L)}$	SVM _L propagation delay	SVMLE = 1, $dV_{CORE}/dt = 10 \text{ mV}/\mu\text{s}$, SVM_LFP = 1		2.5		μs
		SVMLE = 1, $dV_{CORE}/dt = 1 \text{ mV}/\mu\text{s}$, SVM_LFP = 0		20		
$t_{(SVM_L)}$	SVM _L on or off delay time	SVMLE = 0 → 1, $dV_{CORE}/dt = 10 \text{ mV}/\mu\text{s}$, SVM_LFP = 1		12.5		μs
		SVMLE = 0 → 1, $dV_{CORE}/dt = 1 \text{ mV}/\mu\text{s}$, SVM_LFP = 0		100		

5.25 Wake-up Times From Low-Power Modes and Reset

over recommended ranges of supply voltage and operating free-air temperature (unless otherwise noted)

PARAMETER		TEST CONDITIONS	MIN	TYP	MAX	UNIT
$t_{\text{WAKE-UP-FAST}}$	Wake-up time from LPM2, LPM3, or LPM4 to active mode ⁽¹⁾	PMMCOREV = SVSMLRRL = n (where n = 0, 1, 2, or 3), SVSLFP = 1			$f_{\text{MCLK}} \geq 4.0 \text{ MHz}$	5
					$f_{\text{MCLK}} < 4.0 \text{ MHz}$	6
$t_{\text{WAKE-UP-SLOW}}$	Wake-up time from LPM2, LPM3, or LPM4 to active mode ⁽²⁾⁽³⁾	PMMCOREV = SVSMLRRL = n (where n = 0, 1, 2, or 3), SVSLFP = 0		150	165	μs
$t_{\text{WAKE-UP-RESET}}$	Wake-up time from $\overline{\text{RST}}$ or BOR event to active mode ⁽⁴⁾			2	3	ms

- (1) This value represents the time from the wake-up event to the first active edge of MCLK. The wake-up time depends on the performance mode of the low-side supervisor (SVS_L) and low-side monitor (SVM_L). $t_{\text{WAKE-UP-FAST}}$ is possible with SVS_L and SVM_L in full performance mode or disabled. For specific register settings, see the *Low-Side SVS and SVM Control and Performance Mode Selection* section in the *Power Management Module and Supply Voltage Supervisor* chapter of the *CC430 Family User's Guide*.
- (2) This value represents the time from the wake-up event to the first active edge of MCLK. The wake-up time depends on the performance mode of the low-side supervisor (SVS_L) and low-side monitor (SVM_L). $t_{\text{WAKE-UP-SLOW}}$ is set with SVS_L and SVM_L in normal mode (low current mode). For specific register settings, see the *Low-Side SVS and SVM Control and Performance Mode Selection* section in the *Power Management Module and Supply Voltage Supervisor* chapter of the *CC430 Family User's Guide*.
- (3) The wake-up times from LPM0 and LPM1 to AM are not specified. They are proportional to MCLK cycle time but are not affected by the performance mode settings as for LPM2, LPM3, and LPM4.
- (4) This value represents the time from the wake-up event to the reset vector execution.

5.26 Timer_A

over recommended ranges of supply voltage and operating free-air temperature (unless otherwise noted)

PARAMETER		TEST CONDITIONS	V _{CC}	MIN	MAX	UNIT
f_{TA}	Timer_A input clock frequency	Internal: SMCLK or ACLK, External: TACLK, Duty cycle = 50% ±10%	1.8 V, 3 V		25	MHz
$t_{\text{TA,cap}}$	Timer_A capture timing	All capture inputs, Minimum pulse duration required for capture	1.8 V, 3 V	20		ns

5.27 USCI (UART Mode) Clock Frequency

PARAMETER		TEST CONDITIONS	MIN	MAX	UNIT
f _{USCI}	USCI input clock frequency	Internal: SMCLK or ACLK, External: UCLK, Duty cycle = 50% ±10%		f _{SYSTEM}	MHz
f _{BITCLK}	BITCLK clock frequency (equals baud rate in Mbaud)			1	MHz

5.28 USCI (UART Mode)

over recommended ranges of supply voltage and operating free-air temperature (unless otherwise noted)

PARAMETER		V _{CC}	MIN	MAX	UNIT
t _r	UART receive deglitch time ⁽¹⁾	2.2 V	50	600	ns
		3 V	50	600	

- (1) Pulses on the UART receive input (UCxRX) shorter than the UART receive deglitch time are suppressed. To ensure that pulses are correctly recognized, their duration should exceed the maximum specification of the deglitch time.

5.29 USCI (SPI Master Mode) Clock Frequency

PARAMETER		TEST CONDITIONS	MIN	MAX	UNIT
f _{USCI}	USCI input clock frequency	Internal: SMCLK or ACLK, Duty cycle = 50% ±10%		f _{SYSTEM}	MHz

5.30 USCI (SPI Master Mode)

over recommended ranges of supply voltage and operating free-air temperature (unless otherwise noted)⁽¹⁾ (see [Figure 5-14](#) and [Figure 5-15](#))

PARAMETER		TEST CONDITIONS	PMMCOREVx	V _{CC}	MIN	MAX	UNIT
t _{SU,MI}	SOMI input data setup time		0	1.8 V	55	ns	
				3 V	38		
			3	2.4 V	30		
				3 V	25		
t _{HD,MI}	SOMI input data hold time		0	1.8 V	0	ns	
				3 V	0		
			3	2.4 V	0		
				3 V	0		
t _{VALID,MO}	SIMO output data valid time ⁽²⁾	UCLK edge to SIMO valid, C _L = 20 pF	0	1.8 V	20	ns	
				3 V	18		
			3	2.4 V	16		
				3 V	15		
t _{HD,MO}	SIMO output data hold time ⁽³⁾	C _L = 20 pF	0	1.8 V	-10	ns	
				3 V	-8		
			3	2.4 V	-10		
				3 V	-8		

- (1) $f_{UCxCLK} = 1/2t_{LO/HI}$ with $t_{LO/HI} \geq \max(t_{VALID,MO}(USCI) + t_{SU,SI}(Slave), t_{SU,MI}(USCI) + t_{VALID,SO}(Slave))$
 For the slave parameters $t_{SU,SI}(Slave)$ and $t_{VALID,SO}(Slave)$, see the SPI parameters of the attached slave.
- (2) Specifies the time to drive the next valid data to the SIMO output after the output changing UCLK clock edge. See the timing diagrams in [Figure 5-14](#) and [Figure 5-15](#).
- (3) Specifies how long data on the SIMO output is valid after the output changing UCLK clock edge. Negative values indicate that the data on the SIMO output can become invalid before the output changing clock edge observed on UCLK. See the timing diagrams in [Figure 5-14](#) and [Figure 5-15](#).

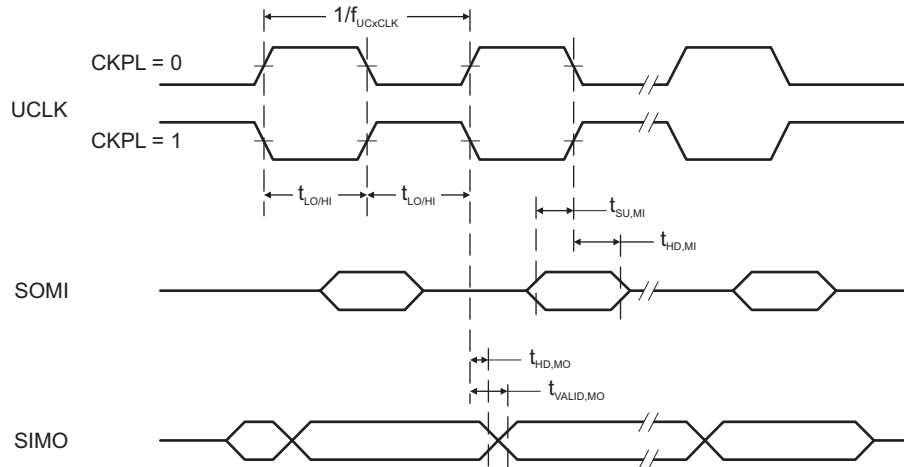

Figure 5-14. SPI Master Mode, CKPH = 0

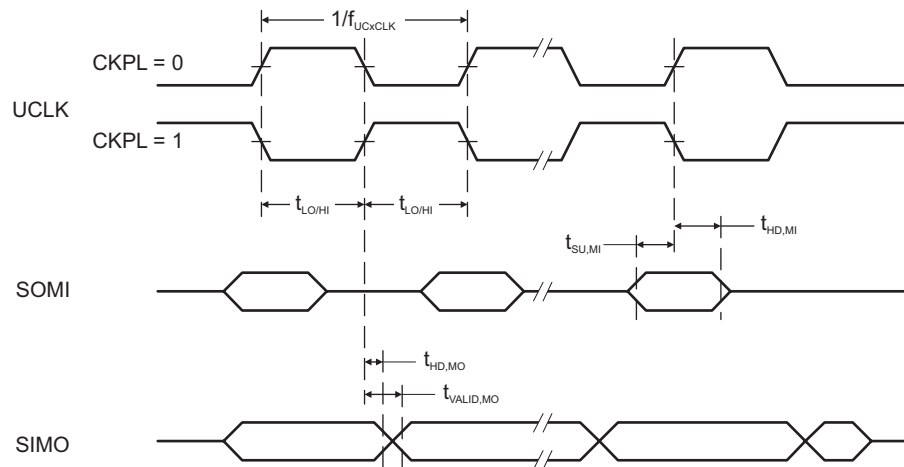

Figure 5-15. SPI Master Mode, CKPH = 1

5.31 USCI (SPI Slave Mode)

over recommended ranges of supply voltage and operating free-air temperature (unless otherwise noted)⁽¹⁾ (see [Figure 5-16](#) and [Figure 5-17](#))

PARAMETER		TEST CONDITIONS	PMMCOREVx	V _{CC}	MIN	MAX	UNIT
t _{STE,LEAD}	STE lead time, STE low to clock		0	1.8 V	11	8	ns
				3 V	8		
			3	2.4 V	7	6	
				3 V	6		
t _{STE,LAG}	STE lag time, Last clock to STE high		0	1.8 V	3	3	ns
				3 V	3		
			3	2.4 V	3	3	
				3 V	3		
t _{STE,ACC}	STE access time, STE low to SOMI data out		0	1.8 V	66	50	ns
				3 V	50		
			3	2.4 V	36	30	
				3 V	30		
t _{STE,DIS}	STE disable time, STE high to SOMI high impedance		0	1.8 V	30	23	ns
				3 V	23		
			3	2.4 V	16	13	
				3 V	13		
t _{SU,SI}	SIMO input data setup time		0	1.8 V	5	5	ns
				3 V	5		
			3	2.4 V	2	2	
				3 V	2		
t _{HD,SI}	SIMO input data hold time		0	1.8 V	5	5	ns
				3 V	5		
			3	2.4 V	5	5	
				3 V	5		
t _{VALID,SO}	SOMI output data valid time ⁽²⁾	UCLK edge to SOMI valid, C _L = 20 pF	0	1.8 V	76	60	ns
				3 V	60		
			3	2.4 V	44	40	
				3 V	40		
t _{HD,SO}	SOMI output data hold time ⁽³⁾	C _L = 20 pF	0	1.8 V	18	12	ns
				3 V	12		
			3	2.4 V	10	8	
				3 V	8		

- (1) $f_{UCxCLK} = 1/2t_{LO/HI}$ with $t_{LO/HI} \geq \max(t_{VALID,MO(Master)} + t_{SU,SI(USCI)}, t_{SU,MI(Master)} + t_{VALID,SO(USCI)})$
 For the master parameters $t_{SU,MI(Master)}$ and $t_{VALID,MO(Master)}$, see the SPI parameters of the attached master.
- (2) Specifies the time to drive the next valid data to the SOMI output after the output changing UCLK clock edge. See the timing diagrams in [Figure 5-16](#) and [Figure 5-17](#).
- (3) Specifies how long data on the SOMI output is valid after the output changing UCLK clock edge. See the timing diagrams in [Figure 5-16](#) and [Figure 5-17](#).

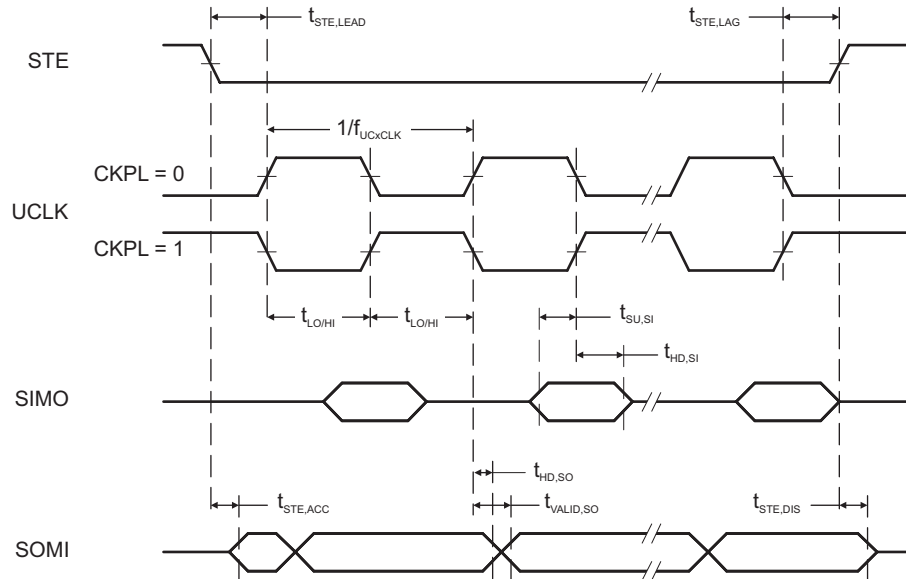

Figure 5-16. SPI Slave Mode, CKPH = 0

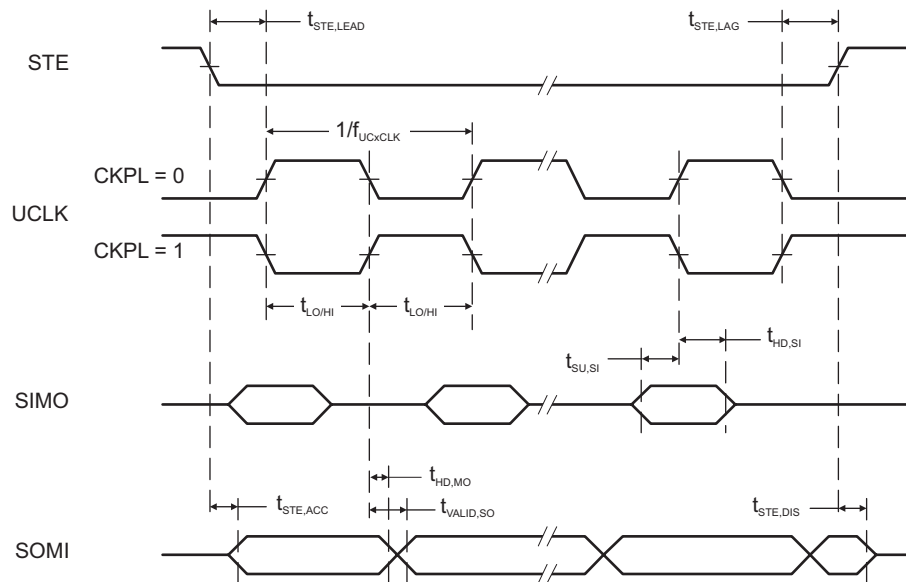

Figure 5-17. SPI Slave Mode, CKPH = 1

5.32 USCI (I²C Mode)

over recommended ranges of supply voltage and operating free-air temperature (unless otherwise noted) (see [Figure 5-18](#))

PARAMETER		TEST CONDITIONS	V _{CC}	MIN	MAX	UNIT
f _{USCI}	USCI input clock frequency	Internal: SMCLK, ACLK External: UCLK Duty cycle = 50% ±10%		f _{SYSTEM}		MHz
f _{SCL}	SCL clock frequency		2.2 V, 3 V	0	400	kHz
t _{HD,STA}	Hold time (repeated) START	f _{SCL} ≤ 100 kHz	2.2 V, 3 V	4.0		μs
		f _{SCL} > 100 kHz		0.6		
t _{SU,STA}	Setup time for a repeated START	f _{SCL} ≤ 100 kHz	2.2 V, 3 V	4.7		μs
		f _{SCL} > 100 kHz		0.6		
t _{HD,DAT}	Data hold time		2.2 V, 3 V	0		ns
t _{SU,DAT}	Data setup time		2.2 V, 3 V	250		ns
t _{SU,STO}	Setup time for STOP	f _{SCL} ≤ 100 kHz	2.2 V, 3 V	4.0		μs
		f _{SCL} > 100 kHz		0.6		
t _{SP}	Pulse duration of spikes suppressed by input filter		2.2 V	50	600	ns
			3 V	50	600	

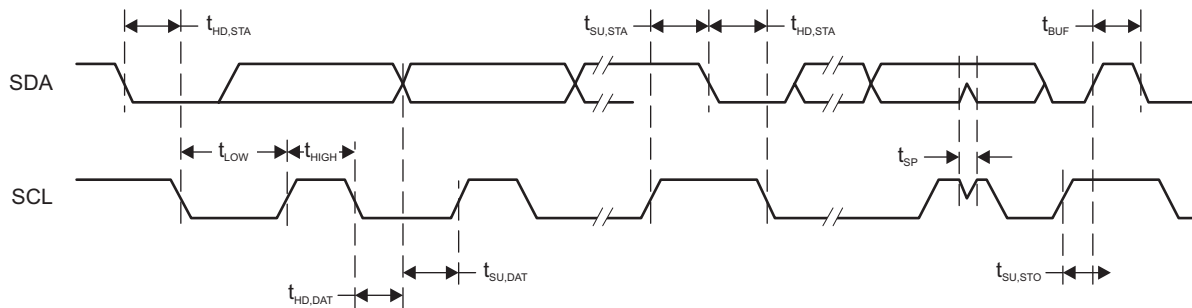

Figure 5-18. I²C Mode Timing

5.33 LCD_B Operating Conditions

PARAMETER	CONDITIONS	MIN	NOM	MAX	UNIT			
$V_{CC,LCD_B,CP}$ en,3.6	Supply voltage range, charge pump enabled, $V_{LCD} \leq 3.6$ V	LCDPEN = 1, $0000 < VLCDx \leq 1111$ (charge pump enabled, $V_{LCD} \leq 3.6$ V)			2.2	3.6	V	
$V_{CC,LCD_B,CP}$ en,3.3	Supply voltage range, charge pump enabled, $V_{LCD} \leq 3.3$ V	LCDPEN = 1, $0000 < VLCDx \leq 1100$ (charge pump enabled, $V_{LCD} \leq 3.3$ V)			2.0	3.6	V	
$V_{CC,LCD_B,int. bias}$	Supply voltage range, internal biasing, charge pump disabled	LCDPEN = 0, VLCDEXT = 0			2.4	3.6	V	
$V_{CC,LCD_B,ext. bias}$	Supply voltage range, external biasing, charge pump disabled	LCDPEN = 0, VLCDEXT = 0			2.4	3.6	V	
$V_{CC,LCD_B,VLCDEXT}$	Supply voltage range, external LCD voltage, internal or external biasing, charge pump disabled	LCDPEN = 0, VLCDEXT = 1			2.0	3.6	V	
$V_{LCDCAP/R33}$	External LCD voltage at LCDCAP/R33, internal or external biasing, charge pump disabled	LCDPEN = 0, VLCDEXT = 1			2.4	3.6	V	
C_{LCDCAP}	Capacitor on LCDCAP when charge pump enabled	LCDPEN = 1, $VLCDx > 0000$ (charge pump enabled)			4.7	4.7	10	μ F
f_{Frame}	LCD frame frequency range	$f_{LCD} = 2 \times mux \times f_{FRAME}$ with $mux = 1$ (static), 2, 3, 4			0	100	Hz	
$f_{ACLK,in}$	ACLK input frequency range				30	32	40	kHz
C_{Panel}	Panel capacitance	100-Hz frame frequency			10000		pF	
V_{R33}	Analog input voltage at R33	LCDPEN = 0, VLCDEXT = 1			2.4	$V_{CC} + 0.2$	V	
$V_{R23,1/3bias}$	Analog input voltage at R23	LCDREXT = 1, LCDEXTBIAS = 1, LCD2B = 0			V_{R13}	$V_{R33} + \frac{V_{R03} + 2/3 \times (V_{R33} - V_{R03})}{V_{R03}}$	V_{R33}	V
$V_{R13,1/3bias}$	Analog input voltage at R13 with 1/3 biasing	LCDREXT = 1, LCDEXTBIAS = 1, LCD2B = 0			V_{R03}	$V_{R03} + \frac{1/3 \times (V_{R33} - V_{R03})}{V_{R03}}$	V_{R23}	V
$V_{R13,1/2bias}$	Analog input voltage at R13 with 1/2 biasing	LCDREXT = 1, LCDEXTBIAS = 1, LCD2B = 1			V_{R03}	$V_{R03} + \frac{1/2 \times (V_{R33} - V_{R03})}{V_{R03}}$	V_{R33}	V
V_{R03}	Analog input voltage at R03	R0EXT = 1			V_{SS}			V
$V_{LCD} - V_{R03}$	Voltage difference between V_{LCD} and R03	LCDPEN = 0, R0EXT = 1			2.4	$V_{CC} + 0.2$		V
$V_{LCDREF/R13}$	External LCD reference voltage applied at LCDREF/R13	VLCDFREFx = 01			0.8	1.2	1.5	V

5.34 LCD_B Electrical Characteristics

over operating free-air temperature range (unless otherwise noted)

PARAMETER	TEST CONDITIONS	V _{CC}	MIN	TYP	MAX	UNIT
V _{LCD}	LCD voltage	VLCDx = 0000, VLCDEXT = 0	2.4 V to 3.6 V	V _{CC}		V
		LCDCPEN = 1, VLCDx = 0001	2 V to 3.6 V	2.54		
		LCDCPEN = 1, VLCDx = 0010	2 V to 3.6 V	2.60		
		LCDCPEN = 1, VLCDx = 0011	2 V to 3.6 V	2.66		
		LCDCPEN = 1, VLCDx = 0100	2 V to 3.6 V	2.72		
		LCDCPEN = 1, VLCDx = 0101	2 V to 3.6 V	2.78		
		LCDCPEN = 1, VLCDx = 0110	2 V to 3.6 V	2.84		
		LCDCPEN = 1, VLCDx = 0111	2 V to 3.6 V	2.90		
		LCDCPEN = 1, VLCDx = 1000	2 V to 3.6 V	2.96		
		LCDCPEN = 1, VLCDx = 1001	2 V to 3.6 V	3.02		
		LCDCPEN = 1, VLCDx = 1010	2 V to 3.6 V	3.08		
		LCDCPEN = 1, VLCDx = 1011	2 V to 3.6 V	3.14		
		LCDCPEN = 1, VLCDx = 1100	2 V to 3.6 V	3.20		
		LCDCPEN = 1, VLCDx = 1101	2.2 V to 3.6 V	3.26		
		LCDCPEN = 1, VLCDx = 1110	2.2 V to 3.6 V	3.32		
LCDCPEN = 1, VLCDx = 1111	2.2 V to 3.6 V	3.38	3.6			
I _{CC,Peak,CP}	Peak supply currents due to charge pump activities	LCDCPEN = 1, VLCDx = 1111	2.2 V	200		μA
t _{LCD,CP,on}	Time to charge C _{LCD} when discharged	C _{LCD,CAP} = 4.7μF, LCDCPEN = 0→1, VLCDx = 1111	2.2 V	100	500	ms
I _{CP,Load}	Maximum charge pump load current	LCDCPEN = 1, VLCDx = 1111	2.2 V	50		μA
R _{LCD,Seg}	LCD driver output impedance, segment lines	LCDCPEN = 1, VLCDx = 1000, I _{LOAD} = ±10 μA	2.2 V		10	kΩ
R _{LCD,COM}	LCD driver output impedance, common lines	LCDCPEN = 1, VLCDx = 1000, I _{LOAD} = ±10 μA	2.2 V		10	kΩ

5.35 12-Bit ADC, Power Supply and Input Range Conditions

over recommended ranges of supply voltage and operating free-air temperature (unless otherwise noted)⁽¹⁾

PARAMETER		TEST CONDITIONS	V _{CC}	MIN	TYP	MAX	UNIT
AV _{CC}	Analog supply voltage, full performance	AVCC and DVCC are connected together, AVSS and DVSS are connected together, V _(AVSS) = V _(DVSS) = 0 V		2.2		3.6	V
V _(Ax)	Analog input voltage range ⁽²⁾	All ADC12 analog input pins Ax		0		AV _{CC}	V
I _{ADC12_A}	Operating supply current into AVCC terminal ⁽³⁾	f _{ADC12CLK} = 5.0 MHz, ADC12ON = 1, REFON = 0, SHT0 = 0, SHT1 = 0, ADC12DIV = 0	2.2 V		125	155	μA
			3 V		150	220	
C _I	Input capacitance	Only one terminal Ax can be selected at one time	2.2 V		20	25	pF
R _I	Input MUX ON resistance	0 V ≤ V _{Ax} ≤ AV _{CC}		10	200	1900	Ω

(1) The leakage current is specified by the digital I/O input leakage.

(2) The analog input voltage range must be within the selected reference voltage range V_{R+} to V_{R-} for valid conversion results. If the reference voltage is supplied by an external source or if the internal reference voltage is used and REFOUT = 1, then decoupling capacitors are required. See [Section 5.40](#) and [Section 5.41](#).

(3) The internal reference supply current is not included in current consumption parameter I_{ADC12_A}.

5.36 12-Bit ADC, Timing Parameters

over recommended ranges of supply voltage and operating free-air temperature (unless otherwise noted)

PARAMETER		TEST CONDITIONS	V _{CC}	MIN	TYP	MAX	UNIT
f _{ADC12CLK}	ADC conversion clock	For specified performance of ADC12 linearity parameters using an external reference voltage or AVCC as reference ⁽¹⁾	2.2 V, 3 V	0.45	4.8	5.0	MHz
		For specified performance of ADC12 linearity parameters using the internal reference ⁽²⁾		0.45	2.4	4.0	
		For specified performance of ADC12 linearity parameters using the internal reference ⁽³⁾		0.45	2.4	2.7	
f _{ADC12OSC}	Internal ADC12 oscillator ⁽⁴⁾	ADC12DIV = 0, f _{ADC12CLK} = f _{ADC12OSC}	2.2 V, 3 V	4.2	4.8	5.4	MHz
t _{CONVERT}	Conversion time	REFON = 0, Internal oscillator, f _{ADC12OSC} = 4.2 MHz to 5.4 MHz	2.2 V, 3 V	2.4		3.1	μs
		External f _{ADC12CLK} from ACLK, MCLK or SMCLK, ADC12SSEL ≠ 0			13 × 1 / f _{ADC12CLK}		
t _{Sample}	Sampling time	R _S = 400 Ω, R _I = 1000 Ω, C _I = 30 pF, τ = (R _S + R _I) × C _I ⁽⁵⁾	2.2 V, 3 V	1000			ns

(1) REFOUT = 0, external reference voltage: SREF2 = 0, SREF1 = 1, SREF0 = 0. AVCC as reference voltage: SREF2 = 0, SREF1 = 0, SREF0 = 0. The specified performance of the ADC12 linearity is ensured when using the ADC12OSC. For other clock sources, the specified performance of the ADC12 linearity is ensured with f_{ADC12CLK} maximum of 5.0 MHz.

(2) SREF2 = 0, SREF1 = 1, SREF0 = 0, ADC12SR = 0, REFOUT = 1

(3) SREF2 = 0, SREF1 = 1, SREF0 = 0, ADC12SR = 0, REFOUT = 0. The specified performance of the ADC12 linearity is ensured when using the ADC12OSC divided by 2.

(4) The ADC12OSC is sourced directly from MODOSC inside the UCS.

(5) Approximately 10 Tau (τ) are needed to get an error of less than ±0.5 LSB:

$$t_{\text{sample}} = \ln(2^{n+1}) \times (R_S + R_I) \times C_I + 800 \text{ ns, where } n = \text{ADC resolution} = 12, R_S = \text{external source resistance}$$

5.37 12-Bit ADC, Linearity Parameters Using an External Reference Voltage or AVCC as Reference Voltage

over recommended ranges of supply voltage and operating free-air temperature (unless otherwise noted)

PARAMETER		TEST CONDITIONS	V _{CC}	MIN	TYP	MAX	UNIT
E _I	Integral linearity error ⁽¹⁾	1.4 V ≤ dVREF ≤ 1.6 V ⁽²⁾	2.2 V, 3 V			±2.0	LSB
		1.6 V < dVREF ⁽²⁾				±1.7	
E _D	Differential linearity error ⁽¹⁾	See ⁽²⁾	2.2 V, 3 V			±1.0	LSB
E _O	Offset error ⁽³⁾	dVREF ≤ 2.2 V ⁽²⁾	2.2 V, 3 V		±1.0	±2.0	LSB
		dVREF > 2.2 V ⁽²⁾			±1.0	±2.0	
E _G	Gain error ⁽³⁾	See ⁽²⁾	2.2 V, 3 V		±1.0	±2.0	LSB
E _T	Total unadjusted error	dVREF ≤ 2.2 V ⁽²⁾	2.2 V, 3 V		±1.4	±3.5	LSB
		dVREF > 2.2 V ⁽²⁾			±1.4	±3.5	

(1) Parameters are derived using the histogram method.

(2) The external reference voltage is selected by: SREF2 = 0 or 1, SREF1 = 1, SREF0 = 0. dVREF = V_{R+} - V_{R-}, V_{R+} < AVCC, V_{R-} > AVSS. Unless otherwise mentioned, dVREF > 1.5 V. Impedance of the external reference voltage R < 100 Ω and two decoupling capacitors, 10 μF and 100 nF, should be connected to VREF+/VREF- to decouple the dynamic current. Also see the [CC430 Family User's Guide](#).

(3) Parameters are derived using a best fit curve.

5.38 12-Bit ADC, Linearity Parameters Using the Internal Reference Voltage

over recommended ranges of supply voltage and operating free-air temperature (unless otherwise noted)

PARAMETER		TEST CONDITIONS ⁽¹⁾		V _{CC}	MIN	TYP	MAX	UNIT
E _I	Integral linearity error ⁽²⁾	ADC12SR = 0, REFOUT = 1	f _{ADC12CLK} ≤ 4.0 MHz	2.2 V, 3 V			±1.7	LSB
		ADC12SR = 0, REFOUT = 0	f _{ADC12CLK} ≤ 2.7 MHz				±2.5	
E _D	Differential linearity error ⁽²⁾	ADC12SR = 0, REFOUT = 1	f _{ADC12CLK} ≤ 4.0 MHz	2.2 V, 3 V	-1.0		+2.0	LSB
		ADC12SR = 0, REFOUT = 1	f _{ADC12CLK} ≤ 2.7 MHz		-1.0		+1.5	
		ADC12SR = 0, REFOUT = 0	f _{ADC12CLK} ≤ 2.7 MHz		-1.0		+2.5	
E _O	Offset error ⁽³⁾	ADC12SR = 0, REFOUT = 1	f _{ADC12CLK} ≤ 4.0 MHz	2.2 V, 3 V		±1.0	±2.0	LSB
		ADC12SR = 0, REFOUT = 0	f _{ADC12CLK} ≤ 2.7 MHz			±1.0	±2.0	
E _G	Gain error ⁽³⁾	ADC12SR = 0, REFOUT = 1	f _{ADC12CLK} ≤ 4.0 MHz	2.2 V, 3 V		±1.0	±2.0	LSB
		ADC12SR = 0, REFOUT = 0	f _{ADC12CLK} ≤ 2.7 MHz				±1.5% ⁽⁴⁾	VREF
E _T	Total unadjusted error	ADC12SR = 0, REFOUT = 1	f _{ADC12CLK} ≤ 4.0 MHz	2.2 V, 3 V		±1.4	±3.5	LSB
		ADC12SR = 0, REFOUT = 0	f _{ADC12CLK} ≤ 2.7 MHz				±1.5% ⁽⁴⁾	VREF

(1) The internal reference voltage is selected by: SREF2 = 0 or 1, SREF1 = 1, SREF0 = 1. dVREF = V_{R+} - V_{R-}.

(2) Parameters are derived using the histogram method.

(3) Parameters are derived using a best fit curve.

(4) The gain error and total unadjusted error are dominated by the accuracy of the integrated reference module absolute accuracy. In this mode the reference voltage used by the ADC12_A is not available on a pin.

5.39 12-Bit ADC, Temperature Sensor and Built-In V_{MID} ⁽¹⁾

over recommended ranges of supply voltage and operating free-air temperature (unless otherwise noted)

PARAMETER		TEST CONDITIONS	V_{CC}	MIN	TYP	MAX	UNIT
V_{SENSOR}	See ⁽²⁾ ⁽³⁾	ADC12ON = 1, INCH = 0Ah, $T_A = 0^\circ\text{C}$	2.2 V	680			mV
			3 V	680			
TC_{SENSOR}	See ⁽³⁾	ADC12ON = 1, INCH = 0Ah	2.2 V	2.25			mV/ $^\circ\text{C}$
			3 V	2.25			
$t_{SENSOR(sample)}$	Sample time required if channel 10 is selected ⁽⁴⁾	ADC12ON = 1, INCH = 0Ah, Error of conversion result ≤ 1 LSB	2.2 V	30			μs
			3 V	30			
V_{MID}	AV _{CC} divider at channel 11, V _{AVCC} factor	ADC12ON = 1, INCH = 0Bh		0.48	0.5	0.52	V _{AVCC}
			2.2 V	1.06	1.1	1.14	V
	AV _{CC} divider at channel 11	ADC12ON = 1, INCH = 0Bh	3 V	1.44	1.5	1.56	
			2.2 V, 3 V	1000			ns

- (1) The temperature sensor is provided by the REF module. See the REF module parametric, I_{REF+} , regarding the current consumption of the temperature sensor.
- (2) The temperature sensor offset can be significant. TI recommends a single-point calibration to minimize the offset error of the built-in temperature sensor.
- (3) The device descriptor structure contains calibration values for $30^\circ\text{C} \pm 3^\circ\text{C}$ and $85^\circ\text{C} \pm 3^\circ\text{C}$ for each of the available reference voltage levels. The sensor voltage can be computed as $V_{SENSE} = TC_{SENSOR} \times (\text{Temperature}, ^\circ\text{C}) + V_{SENSOR}$, where TC_{SENSOR} and V_{SENSOR} can be computed from the calibration values for higher accuracy.
- (4) The typical equivalent impedance of the sensor is 51 k Ω . The sample time required includes the sensor-on time $t_{SENSOR(on)}$.
- (5) The on time $t_{VMID(on)}$ is included in the sampling time $t_{VMID(sample)}$; no additional on time is needed.

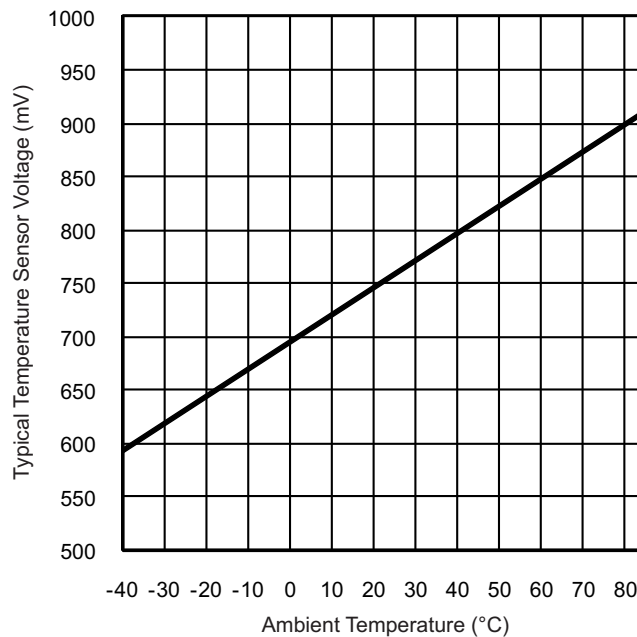

Figure 5-19. Typical Temperature Sensor Voltage

5.40 REF, External Reference

over recommended ranges of supply voltage and operating free-air temperature (unless otherwise noted)⁽¹⁾

PARAMETER		TEST CONDITIONS	V _{CC}	MIN	TYP	MAX	UNIT
V _{eREF+}	Positive external reference voltage input	V _{eREF+} > V _{REF-} /V _{eREF-} ⁽²⁾		1.4		AV _{CC}	V
V _{REF-} /V _{eREF-}	Negative external reference voltage input	V _{eREF+} > V _{REF-} /V _{eREF-} ⁽³⁾		0		1.2	V
(V _{eREF+} – V _{REF-} /V _{eREF-})	Differential external reference voltage input	V _{eREF+} > V _{REF-} /V _{eREF-} ⁽⁴⁾		1.4		AV _{CC}	V
I _{VeREF+} I _{VREF-/VeREF-}	Static input current	1.4 V ≤ V _{eREF+} ≤ V _{AVCC} , V _{eREF-} = 0 V, f _{ADC12CLK} = 5 MHz, ADC12SHTx = 1h, Conversion rate 200 ksps	2.2 V, 3 V		±8.5	±26	μA
		1.4 V ≤ V _{eREF+} ≤ V _{AVCC} , V _{eREF-} = 0 V, f _{ADC12CLK} = 5 MHz, ADC12SHTx = 8h, Conversion rate 20 ksps	2.2 V, 3 V			±1	
C _{VREF+/-}	Capacitance at VREF+ or VREF- terminal, external reference ⁽⁵⁾			10			μF

- (1) The external reference is used during ADC conversion to charge and discharge the capacitance array. The input capacitance, C_i, is also the dynamic load for an external reference during conversion. The dynamic impedance of the reference supply should follow the recommendations on analog-source impedance to allow the charge to settle for 12-bit accuracy.
- (2) The accuracy limits the minimum positive external reference voltage. Lower reference voltage levels may be applied with reduced accuracy requirements.
- (3) The accuracy limits the maximum negative external reference voltage. Higher reference voltage levels may be applied with reduced accuracy requirements.
- (4) The accuracy limits minimum external differential reference voltage. Lower differential reference voltage levels may be applied with reduced accuracy requirements.
- (5) Two decoupling capacitors, 10 μF and 100 nF, should be connected to VREF to decouple the dynamic current required for an external reference source if it is used for the ADC12_A. Also see the [CC430 Family User's Guide](#).

5.41 REF, Built-In Reference

over recommended ranges of supply voltage and operating free-air temperature (unless otherwise noted)⁽¹⁾

PARAMETER	TEST CONDITIONS	V _{CC}	MIN	TYP	MAX	UNIT
V _{REF+} Positive built-in reference voltage output	REFVSEL = 2 for 2.5 V, REFON = REFOUT = 1, I _{VREF+} = 0 A	3 V		2.41	±1.5%	V
	REFVSEL = 1 for 2 V, REFON = REFOUT = 1, I _{VREF+} = 0 A	3 V		1.93	±1.5%	
	REFVSEL = 0 for 1.5 V, REFON = REFOUT = 1, I _{VREF+} = 0 A	2.2 V, 3 V		1.45	±1.5%	
AV _{CC(min)} AVCC minimum voltage, Positive built-in reference active	REFVSEL = 0 for 1.5 V, reduced performance		1.8			V
	REFVSEL = 0 for 1.5 V		2.2			
	REFVSEL = 1 for 2 V		2.3			
	REFVSEL = 2 for 2.5 V		2.8			
I _{REF+} Operating supply current into AVCC terminal ⁽²⁾⁽³⁾	REFON = 1, REFOUT = 0, REFBURST = 0	3 V		100	140	μA
	REFON = 1, REFOUT = 1, REFBURST = 0	3 V		0.9	1.5	mA
I _{L(VREF+)} Load-current regulation, VREF+ terminal ⁽⁴⁾	REFVSEL = 0, 1, or 2, I _{VREF+} = +10 μA or –1000 μA, AV _{CC} = AV _{CC(min)} for each reference level, REFON = REFOUT = 1				2500	μV/mA
C _{VREF+} Capacitance at VREF+ terminals, internal reference	REFON = REFOUT = 1		20		100	pF
TC _{REF+} Temperature coefficient of built-in reference ⁽⁵⁾	I _{VREF+} = 0 A, REFVSEL = 0, 1, or 2, REFON = 1, REFOUT = 0 or 1			30	50	ppm/ °C
PSRR _{DC} Power supply rejection ratio (DC)	AV _{CC} = AV _{CC(min)} to AV _{CC(max)} , T _A = 25 °C, REFVSEL = 0, 1, or 2, REFON = 1, REFOUT = 0 or 1			120	300	μV/V
PSRR _{AC} Power supply rejection ratio (AC)	AV _{CC} = AV _{CC(min)} to AV _{CC(max)} , T _A = 25 °C, f = 1 kHz, ΔV _{pp} = 100 mV, REFVSEL = 0, 1, or 2, REFON = 1, REFOUT = 0 or 1			6.4		mV/V
t _{SETTLE} Settling time of reference voltage ⁽⁶⁾	AV _{CC} = AV _{CC(min)} to AV _{CC(max)} , REFVSEL = 0, 1, or 2, REFOUT = 0, REFOUT = 0 → 1			75		μs
	AV _{CC} = AV _{CC(min)} to AV _{CC(max)} , C _{VREF} = C _{VREF(maximum)} , REFVSEL = 0, 1, or 2, REFOUT = 1, REFOUT = 0 → 1			75		

- (1) The reference is supplied to the ADC by the REF module and is buffered locally inside the ADC. The ADC uses two internal buffers, one smaller and one larger for driving the VREF+ terminal. When REFOUT = 1, the reference is available at the VREF+ terminal, as well as, used as the reference for the conversion and uses the larger buffer. When REFOUT = 0, the reference is only used as the reference for the conversion and uses the smaller buffer.
- (2) The internal reference current is supplied from the AVCC terminal. Consumption is independent of the ADC12ON control bit, unless a conversion is active. The REFON bit enables to settle the built-in reference before starting an analog-to-digital conversion. REFOUT = 0 represents the current contribution of the smaller buffer. REFOUT = 1 represents the current contribution of the larger buffer without external load.
- (3) The temperature sensor is provided by the REF module. Its current is supplied from the AVCC terminal and is equivalent to I_{REF+} with REFON = 1 and REFOUT = 0.
- (4) Contribution only due to the reference and buffer including package. This does not include resistance due to PCB trace or other causes.
- (5) Calculated using the box method: (MAX(–40°C to 85°C) – MIN(–40°C to 85°C)) / MIN(–40°C to 85°C)/(85°C – (–40°C)).
- (6) The condition is that the error in a conversion started after t_{REFON} is less than ±0.5 LSB. The settling time depends on the external capacitive load when REFOUT = 1.

5.42 Comparator_B

over recommended ranges of supply voltage and operating free-air temperature (unless otherwise noted)

PARAMETER		TEST CONDITIONS	V _{CC}	MIN	TYP	MAX	UNIT
V _{CC}	Supply voltage			1.8		3.6	V
I _{AVCC_COMP}	Comparator operating supply current into AVCC, Excludes reference resistor ladder	CBPWRMD = 00	1.8 V			40	μA
			2.2 V		30	50	
			3 V		40	65	
		CBPWRMD = 01	2.2 V, 3 V		10	30	
		CBPWRMD = 10	2.2 V, 3 V		0.1	0.5	
I _{AVCC_REF}	Quiescent current of local reference voltage amplifier into AVCC	CBREFACC = 1, CBREFLx = 01				22	μA
V _{IC}	Common mode input range			0		V _{CC} – 1	V
V _{OFFSET}	Input offset voltage	CBPWRMD = 00				±20	mV
		CBPWRMD = 01 or 10				±10	
C _{IN}	Input capacitance				5		pF
R _{SIN}	Series input resistance	On (switch closed)			3	4	kΩ
		Off (switch open)		30			MΩ
t _{PD}	Propagation delay, response time	CBPWRMD = 00, CBF = 0				450	ns
		CBPWRMD = 01, CBF = 0				600	
		CBPWRMD = 10, CBF = 0					50
t _{PD,filter}	Propagation delay with filter active	CBPWRMD = 00, CBON = 1, CBF = 1, CBF DLY = 00		0.35	0.6	1.0	μs
		CBPWRMD = 00, CBON = 1, CBF = 1, CBF DLY = 01		0.6	1.0	1.8	
		CBPWRMD = 00, CBON = 1, CBF = 1, CBF DLY = 10		1.0	1.8	3.4	
		CBPWRMD = 00, CBON = 1, CBF = 1, CBF DLY = 11		1.8	3.4	6.5	
t _{EN_CMP}	Comparator enable time, settling time	CBON = 0 to CBON = 1, CBPWRMD = 00 or 01			1	2	μs
		CBON = 0 to CBON = 1, CBPWRMD = 10				100	
t _{EN_REF}	Resistor reference enable time	CBON = 0 to CBON = 1			0.3	1.5	μs
V _{CB_REF}	Reference voltage for a given tap	V _{IN} = reference into resistor ladder, n = 0 to 31				$\frac{V_{IN} \times (n + 1)}{32}$	V

5.43 Flash Memory

over recommended ranges of supply voltage and operating free-air temperature (unless otherwise noted)

PARAMETER		T _J	MIN	TYP	MAX	UNIT
DV _{CC(PGM/ERASE)}	Program and erase supply voltage		1.8		3.6	V
I _{PGM}	Average supply current from DV _{CC} during program			3	5	mA
I _{ERASE}	Average supply current from DV _{CC} during erase			2	6.5	mA
I _{MERASE, IBANK}	Average supply current from DV _{CC} during mass erase or bank erase			2	6.5	mA
t _{CPT}	Cumulative program time ⁽¹⁾				16	ms
	Program and erase endurance		10 ⁴	10 ⁵		cycles
t _{Retention}	Data retention duration	25°C	100			years
t _{Word}	Word or byte program time ⁽²⁾		64		85	μs
t _{Block, 0}	Block program time for first byte or word ⁽²⁾		49		65	μs
t _{Block, 1–(N–1)}	Block program time for each additional byte or word, except for last byte or word ⁽²⁾		37		49	μs
t _{Block, N}	Block program time for last byte or word ⁽²⁾		55		73	μs
t _{Erase}	Erase time for segment erase, mass erase, and bank erase when available ⁽²⁾		23		32	ms
f _{MCLK,MGR}	MCLK frequency in marginal read mode (FCTL4.MGR0 = 1 or FCTL4.MGR1 = 1)		0		1	MHz

- (1) The cumulative program time must not be exceeded when writing to a 128-byte flash block. This parameter applies to all programming methods: individual word write, individual byte write, and block write modes.
- (2) These values are hardwired into the state machine of the flash controller.

5.44 JTAG and Spy-Bi-Wire Interface

over recommended ranges of supply voltage and operating free-air temperature (unless otherwise noted)

PARAMETER		V _{CC}	MIN	TYP	MAX	UNIT
f _{SBW}	Spy-Bi-Wire input frequency	2.2 V, 3 V	0		20	MHz
t _{SBW,Low}	Spy-Bi-Wire low clock pulse duration	2.2 V, 3 V	0.025		15	μs
t _{SBW,En}	Spy-Bi-Wire enable time (TEST high to acceptance of first clock edge) ⁽¹⁾	2.2 V, 3 V			1	μs
t _{SBW,Rst}	Spy-Bi-Wire return to normal operation time		15		100	μs
f _{TCK}	TCK input frequency, 4-wire JTAG ⁽²⁾	2.2 V	0		5	MHz
		3 V	0		10	MHz
R _{internal}	Internal pulldown resistance on TEST	2.2 V, 3 V	45	60	80	kΩ

- (1) Tools that access the Spy-Bi-Wire interface need to wait for the minimum t_{SBW,En} time after pulling the TEST/SBWTCK pin high before applying the first SBWTCK clock edge.
- (2) f_{TCK} may be restricted to meet the timing requirements of the module selected.

5.45 RF1A CC1101-Based Radio Parameters

5.46 Recommended Operating Conditions

PARAMETER	TEST CONDITIONS	MIN	TYP	MAX	UNIT
V _{CC}	Supply voltage range during radio operation	2.0		3.6	V
PMMCOREVx	Core voltage range, PMMCOREVx setting during radio operation	2		3	
RF range		300		348	MHz
		389 ⁽¹⁾		464	
		779		928	
Data rate	2-FSK	0.6		500	kBaud
	2-GFSK, OOK, and ASK	0.6		250	
	(Shaped) MSK (also known as differential offset QPSK) ⁽²⁾	26		500	
RF crystal frequency		26	26	27	MHz
RF crystal tolerance	Total tolerance including initial tolerance, crystal loading, aging, and temperature dependency. ⁽³⁾		±40		ppm
RF crystal load capacitance		10	13	20	pF
RF crystal effective series resistance				100	Ω

(1) If using a 27-MHz crystal, the lower frequency limit for this band is 392 MHz.

(2) If using optional Manchester encoding, the data rate in kbps is half the baud rate.

(3) The acceptable crystal tolerance depends on frequency band, channel bandwidth, and spacing. Also see [DN005 -- CC11xx Sensitivity versus Frequency Offset and Crystal Accuracy](#).

5.47 RF Crystal Oscillator, XT2

T_A = 25°C, V_{CC} = 3 V (unless otherwise noted)⁽¹⁾

PARAMETER	MIN	TYP	MAX	UNIT
Start-up time ⁽²⁾		150	810	μs
Duty cycle	45%	50%	55%	

(1) All measurement results are obtained using the EM430F6137RF900 with BOM according to tested frequency range (see [Table 7-1](#)).

(2) The start-up time depends to a very large degree on the used crystal.

5.48 Current Consumption, Reduced-Power Modes

T_A = 25°C, V_{CC} = 3 V (unless otherwise noted)⁽¹⁾

PARAMETER	TEST CONDITIONS	MIN	TYP	MAX	UNIT
Current consumption	RF crystal oscillator only ⁽²⁾		100		μA
	IDLE state (including RF crystal oscillator)		1.7		mA
	FSTXON state (only the frequency synthesizer is running) ⁽³⁾		9.5		

(1) All measurement results are obtained using the EM430F6137RF900 with BOM according to tested frequency range (see [Table 7-1](#)).

(2) To measure the current, follow this sequence:

- Enable XT2 with XOSC_FORCE_ON = 1.
- Set radio to sleep mode.
- Disable XT2 clock requests from any module.

(3) This current consumption is also representative of other intermediate states when going from IDLE to RX or TX, including the calibration state.

5.49 Current Consumption, Receive Mode

 $T_A = 25^\circ\text{C}$, $V_{CC} = 3\text{ V}$ (unless otherwise noted)⁽¹⁾ ⁽²⁾

PARAMETER	FREQ (MHz)	DATA RATE (kBaud)	TEST CONDITIONS		TYP	UNIT	
Current consumption, RX	315	1.2	Register settings optimized for reduced current	Input at –100 dBm (close to sensitivity limit)	17	mA	
				Input at –40 dBm (well above sensitivity limit)	16		
		38.4		Input at –100 dBm (close to sensitivity limit)	17		
				Input at –40 dBm (well above sensitivity limit)	16		
		250		Input at –100 dBm (close to sensitivity limit)	18		
				Input at –40 dBm (well above sensitivity limit)	16.5		
	433	1.2		Register settings optimized for reduced current	Input at –100 dBm (close to sensitivity limit)		18
					Input at –40 dBm (well above sensitivity limit)		17
		38.4			Input at –100 dBm (close to sensitivity limit)		18
					Input at –40 dBm (well above sensitivity limit)		17
		250			Input at –100 dBm (close to sensitivity limit)		18.5
					Input at –40 dBm (well above sensitivity limit)		17
	868, 915	1.2	Register settings optimized for reduced current ⁽³⁾		Input at –100 dBm (close to sensitivity limit)		16
					Input at –40 dBm (well above sensitivity limit)		15
		38.4			Input at –100 dBm (close to sensitivity limit)		16
					Input at –40 dBm (well above sensitivity limit)		15
		250			Input at –100 dBm (close to sensitivity limit)		16
					Input at –40 dBm (well above sensitivity limit)		15

(1) All measurement results are obtained using the EM430F6137RF900 with BOM according to tested frequency range (see [Table 7-1](#)).

(2) Reduced current setting (MDMCFG2.DEM_DCFILT_OFF = 1) gives a slightly lower current consumption at the cost of a reduction in sensitivity. See [Section 5.55](#) through [Section 5.58](#) for additional details on current consumption and sensitivity.

(3) For 868 or 915 MHz, see [Figure 5-20](#) for current consumption with register settings optimized for sensitivity.

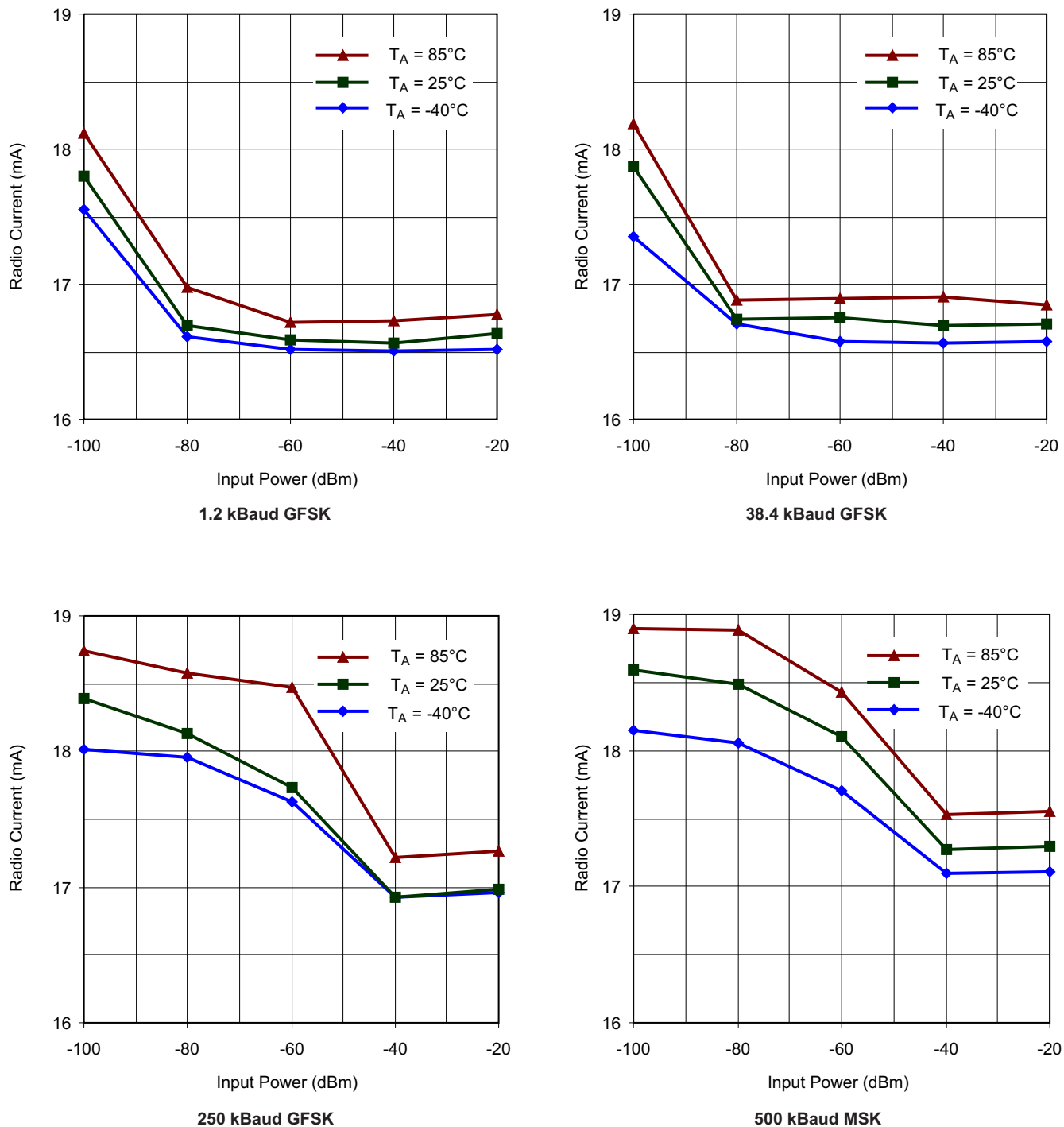

Figure 5-20. Typical RX Current Consumption Over Temperature and Input Power Level, 868 MHz, Sensitivity-Optimized Setting

5.50 Current Consumption, Transmit Mode

 $T_A = 25^\circ\text{C}$, $V_{CC} = 3\text{ V}$ (unless otherwise noted)^{(1) (2)}

PARAMETER	FREQUENCY [MHz}	PATABLE SETTING	OUTPUT POWER (dBm)	TYP	UNIT
Current consumption, TX	315	0xC0	maximum	26	mA
		0xC4	+10	25	
		0x51	0	15	
		0x29	-6	15	
	433	0xC0	maximum	33	
		0xC6	+10	29	
		0x50	0	17	
		0x2D	-6	17	
	868	0xC0	maximum	36	
		0xC3	+10	33	
		0x8D	0	18	
		0x2D	-6	18	
	915	0xC0	maximum	35	
		0xC3	+10	32	
		0x8D	0	18	
		0x2D	-6	18	

- (1) All measurement results are obtained using the EM430F6137RF900 with BOM according to tested frequency range (see [Table 7-1](#)).
- (2) Reduced current setting (MDMCFG2.DEM_DCFLT_OFF = 1) gives a slightly lower current consumption at the cost of a reduction in sensitivity. See [Section 5.55](#) through [Section 5.58](#) for additional details on current consumption and sensitivity.

5.51 Typical TX Current Consumption, 315 MHz

PARAMETER	PATABLE SETTING	OUTPUT POWER (dBm)	V _{CC}	2 V	3 V	3.6 V	UNIT
			T _A	25°C	25°C	25°C	
Current consumption, TX	0xC0	maximum		27.5	26.4	28.1	mA
	0xC4	+10		25.1	25.2	25.3	
	0x51	0		14.4	14.6	14.7	
	0x29	-6		14.2	14.7	15.0	

5.52 Typical TX Current Consumption, 433 MHz

PARAMETER	PATABLE SETTING	OUTPUT POWER (dBm)	V _{CC}	2 V	3 V	3.6 V	UNIT
			T _A	25°C	25°C	25°C	
Current consumption, TX	0xC0	maximum		33.1	33.4	33.8	mA
	0xC6	+10		28.6	28.8	28.8	
	0x50	0		16.6	16.8	16.9	
	0x2D	-6		16.8	17.5	17.8	

5.53 Typical TX Current Consumption, 868 MHz

PARAMETER	PATABLE SETTING	OUTPUT POWER (dBm)	V _{CC} T _A	2 V			3 V			3.6 V			UNIT
				-40°C	25°C	85°C	-40°C	25°C	85°C	-40°C	25°C	85°C	
Current consumption, TX	0xC0	maximum		36.7	35.2	34.2	38.5	35.5	34.9	37.1	35.7	34.7	mA
	0xC3	+10		34.0	32.8	32.0	34.2	33.0	32.5	34.3	33.1	32.2	
	0x8D	0		18.0	17.6	17.5	18.3	17.8	18.1	18.4	18.0	17.7	
	0x2D	-6		17.1	17.0	17.2	17.8	17.8	18.3	18.2	18.1	18.1	

5.54 Typical TX Current Consumption, 915 MHz

PARAMETER	PATABLE SETTING	OUTPUT POWER (dBm)	V _{CC} T _A	2 V			3 V			3.6 V			UNIT
				-40°C	25°C	85°C	-40°C	25°C	85°C	-40°C	25°C	85°C	
Current consumption, TX	0xC0	maximum		35.5	33.8	33.2	36.2	34.8	33.6	36.3	35.0	33.8	mA
	0xC3	+10		33.2	32.0	31.0	33.4	32.1	31.2	33.5	32.3	31.3	
	0x8D	0		17.8	17.4	17.1	18.1	17.6	17.3	18.2	17.8	17.5	
	0x2D	-6		17.0	16.9	16.9	17.7	17.6	17.6	18.1	18.0	18.0	

5.55 RF Receive, Overall

 $T_A = 25^\circ\text{C}$, $V_{CC} = 3\text{ V}$ (unless otherwise noted)⁽¹⁾

PARAMETER	TEST CONDITIONS	MIN	TYP	MAX	UNIT
Digital channel filter bandwidth ⁽²⁾		58		812	kHz
Spurious emissions ^{(3) (4)}	25 MHz to 1 GHz		-68	-57	dBm
	Above 1 GHz		-66	-47	
RX latency	Serial operation ⁽⁵⁾		9		bit

- (1) All measurement results are obtained using the EM430F6137RF900 with BOM according to tested frequency range (see Table 7-1).
- (2) User programmable. The bandwidth limits are proportional to crystal frequency (given values assume a 26.0 MHz crystal)
- (3) Typical radiated spurious emission is -49 dBm measured at the VCO frequency
- (4) Maximum figure is the ETSI EN 300 220 limit
- (5) Time from start of reception until data is available on the receiver data output pin is equal to 9 bit.

5.56 RF Receive, 315 MHz

 $T_A = 25^\circ\text{C}$, $V_{CC} = 3\text{ V}$ (unless otherwise noted)⁽¹⁾

2-FSK, 1% packet error rate, 20-byte packet length, Sensitivity optimized, MDMCFG2.DEM_DCFILT_OFF = 0 (unless otherwise noted)

PARAMETER	DATA RATE (kBaud)	TEST CONDITIONS	TYP	UNIT
Receiver sensitivity	0.6	14.3-kHz deviation, 58-kHz digital channel filter bandwidth	-117	dBm
	1.2	5.2-kHz deviation, 58-kHz digital channel filter bandwidth ⁽²⁾	-111	
	38.4	20-kHz deviation, 100-kHz digital channel filter bandwidth ⁽³⁾	-103	
	250	127-kHz deviation, 540-kHz digital channel filter bandwidth ⁽⁴⁾	-95	
	500	MSK, 812-kHz digital channel filter bandwidth ⁽⁴⁾	-86	

- (1) All measurement results are obtained using the EM430F6137RF900 with BOM according to tested frequency range (see Table 7-1).
- (2) Sensitivity can be traded for current consumption by setting MDMCFG2.DEM_DCFILT_OFF = 1. The typical current consumption is then reduced by approximately 2 mA close to the sensitivity limit. The sensitivity is typically reduced to -109 dBm.
- (3) Sensitivity can be traded for current consumption by setting MDMCFG2.DEM_DCFILT_OFF = 1. The typical current consumption is then reduced by approximately 2 mA close to the sensitivity limit. The sensitivity is typically reduced to -102 dBm.
- (4) MDMCFG2.DEM_DCFILT_OFF = 1 cannot be used for data rates $\geq 250\text{kBaud}$.

5.57 RF Receive, 433 MHz

 $T_A = 25^\circ\text{C}$, $V_{CC} = 3\text{ V}$ (unless otherwise noted)⁽¹⁾

2-FSK, 1% packet error rate, 20-byte packet length, Sensitivity optimized, MDMCFG2.DEM_DCFILT_OFF = 0 (unless otherwise noted)

PARAMETER	DATA RATE (kBaud)	TEST CONDITIONS	TYP	UNIT
Receiver sensitivity	0.6	14.3-kHz deviation, 58-kHz digital channel filter bandwidth	-114	dBm
	1.2	5.2-kHz deviation, 58-kHz digital channel filter bandwidth ⁽²⁾	-111	
	38.4	20-kHz deviation, 100-kHz digital channel filter bandwidth ⁽³⁾	-104	
	250	127-kHz deviation, 540-kHz digital channel filter bandwidth ⁽⁴⁾	-93	
	500	MSK, 812-kHz digital channel filter bandwidth ⁽⁴⁾	-85	

- (1) All measurement results are obtained using the EM430F6137RF900 with BOM according to tested frequency range (see Table 7-1).
- (2) Sensitivity can be traded for current consumption by setting MDMCFG2.DEM_DCFILT_OFF = 1. The typical current consumption is then reduced by approximately 2 mA close to the sensitivity limit. The sensitivity is typically reduced to -109 dBm.
- (3) Sensitivity can be traded for current consumption by setting MDMCFG2.DEM_DCFILT_OFF = 1. The typical current consumption is then reduced by approximately 2 mA close to the sensitivity limit. The sensitivity is typically reduced to -101 dBm.
- (4) MDMCFG2.DEM_DCFILT_OFF = 1 cannot be used for data rates $\geq 250\text{kBaud}$.

5.58 RF Receive, 868 or 915 MHz

$T_A = 25^\circ\text{C}$, $V_{CC} = 3\text{ V}$ (unless otherwise noted)⁽¹⁾

1% packet error rate, 20-byte packet length, Sensitivity optimized, MDMCFG2.DEM_DCFILT_OFF = 0 (unless otherwise noted)

PARAMETER	TEST CONDITIONS	MIN	TYP	MAX	UNIT
0.6-kBaud data rate, 2-FSK, 14.3-kHz deviation, 58-kHz digital channel filter bandwidth (unless otherwise noted)					
Receiver sensitivity			-115		dBm
1.2-kBaud data rate, 2-FSK, 5.2-kHz deviation, 58-kHz digital channel filter bandwidth (unless otherwise noted)					
Receiver sensitivity ⁽²⁾	2-GFSK modulation by setting MDMCFG2.MOD_FORMAT = 2, Gaussian filter with BT = 0.5		-109		dBm
			-109		
Saturation	FIFOTHR.CLOSE_IN_RX =0 ⁽³⁾		-28		dBm
Adjacent channel rejection	Desired channel 3 dB above the sensitivity limit, 100-kHz channel spacing ⁽⁴⁾	-100-kHz offset	39		dB
		+100-kHz offset	39		
Image channel rejection	IF 152 kHz, desired channel 3 dB above the sensitivity limit		29		dB
Blocking	Desired channel 3 dB above the sensitivity limit ⁽⁵⁾	±2-MHz offset	-48		dBm
		±10-MHz offset	-40		
38.4-kBaud data rate, 2-FSK, 20-kHz deviation, 100-kHz digital channel filter bandwidth (unless otherwise noted)					
Receiver sensitivity ⁽⁶⁾	2-GFSK modulation by setting MDMCFG2.MOD_FORMAT = 2, Gaussian filter with BT = 0.5		-102		dBm
			-101		
Saturation	FIFOTHR.CLOSE_IN_RX =0 ⁽³⁾		-19		dBm
Adjacent channel rejection	Desired channel 3 dB above the sensitivity limit, 200-kHz channel spacing ⁽⁵⁾	-200-kHz offset	20		dB
		+200-kHz offset	25		
Image channel rejection	IF 152 kHz, desired channel 3 dB above the sensitivity limit		23		dB
Blocking	Desired channel 3 dB above the sensitivity limit ⁽⁵⁾	±2-MHz offset	-48		dBm
		±10-MHz offset	-40		
250-kBaud data rate, 2-FSK, 127-kHz deviation, 540-kHz digital channel filter bandwidth (unless otherwise noted)					
Receiver sensitivity ⁽⁷⁾	2-GFSK modulation by setting MDMCFG2.MOD_FORMAT = 2, Gaussian filter with BT = 0.5		-90		dBm
			-90		
Saturation	FIFOTHR.CLOSE_IN_RX =0 ⁽³⁾		-19		dBm
Adjacent channel rejection	Desired channel 3 dB above the sensitivity limit, 750-kHz channel spacing ⁽⁸⁾	-750-kHz offset	24		dB
		+750-kHz offset	30		
Image channel rejection	IF 304 kHz, desired channel 3 dB above the sensitivity limit		18		dB
Blocking	Desired channel 3 dB above the sensitivity limit ⁽⁸⁾	±2-MHz offset	-53		dBm
		±10-MHz offset	-39		
500-kBaud data rate, MSK, 812-kHz digital channel filter bandwidth (unless otherwise noted)					
Receiver sensitivity ⁽⁷⁾			-84		dBm
Image channel rejection	IF 355 kHz, desired channel 3 dB above the sensitivity limit		-2		dB
Blocking	Desired channel 3 dB above the sensitivity limit ⁽⁹⁾	±2-MHz offset	-53		dBm
		±10-MHz offset	-38		

(1) All measurement results are obtained using the EM430F6137RF900 with BOM according to tested frequency range (see Table 7-1).

(2) Sensitivity can be traded for current consumption by setting MDMCFG2.DEM_DCFILT_OFF =1. The typical current consumption is then reduced by approximately 2 mA close to the sensitivity limit. The sensitivity is typically reduced to -107 dBm

(3) See [DN010 Close-in Reception with CC1101](#).

(4) See [Figure 5-21](#) for blocking performance at other offset frequencies.

(5) See [Figure 5-22](#) for blocking performance at other offset frequencies.

(6) Sensitivity can be traded for current consumption by setting MDMCFG2.DEM_DCFILT_OFF =1. The typical current consumption is then reduced by approximately 2 mA close to the sensitivity limit. The sensitivity is typically reduced to -100 dBm.

(7) MDMCFG2.DEM_DCFILT_OFF = 1 cannot be used for data rates $\geq 250\text{kBaud}$.

(8) See [Figure 5-23](#) for blocking performance at other offset frequencies.

(9) See [Figure 5-24](#) for blocking performance at other offset frequencies.

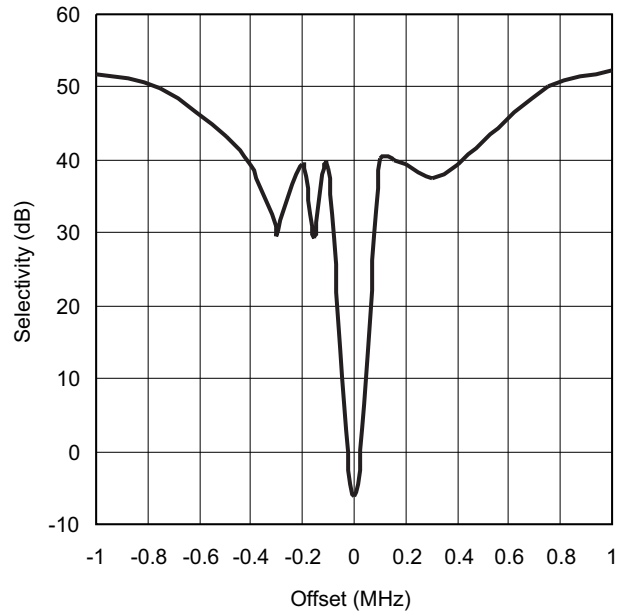
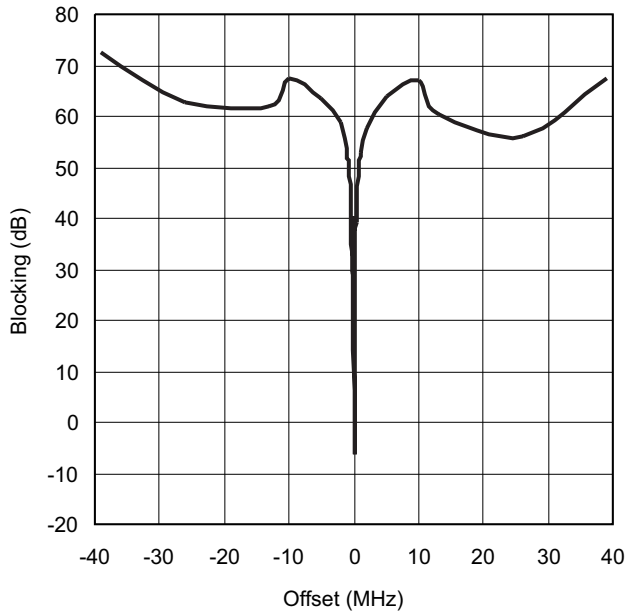

NOTE: 868.3 MHz, 2-FSK, 5.2-kHz deviation, IF is 152.3 kHz, digital channel filter bandwidth is 58 kHz

Figure 5-21. Typical Selectivity at 1.2-kBaud Data Rate

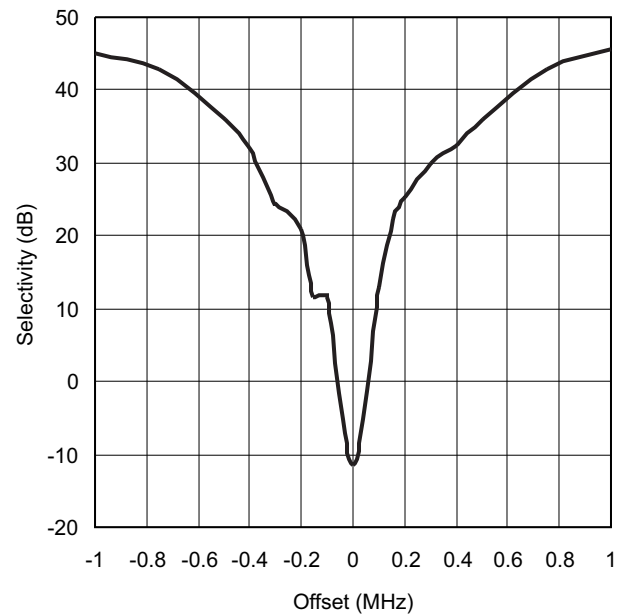
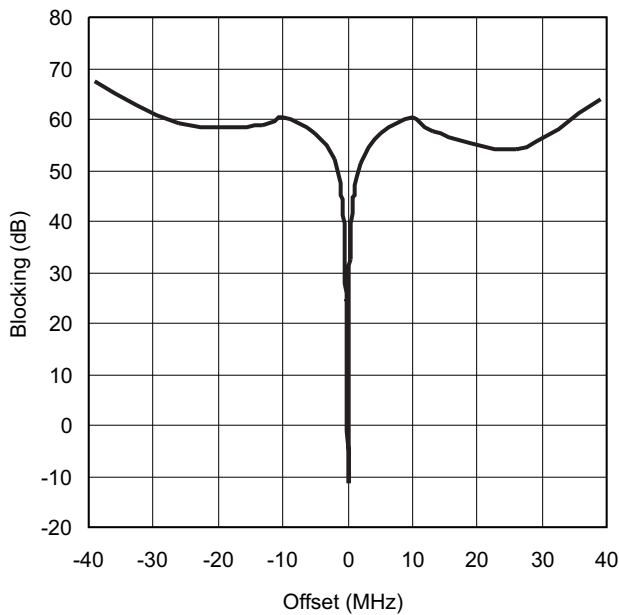

NOTE: 868 MHz, 2-FSK, 20 kHz deviation, IF is 152.3 kHz, digital channel filter bandwidth is 100 kHz

Figure 5-22. Typical Selectivity at 38.4-kBaud Data Rate

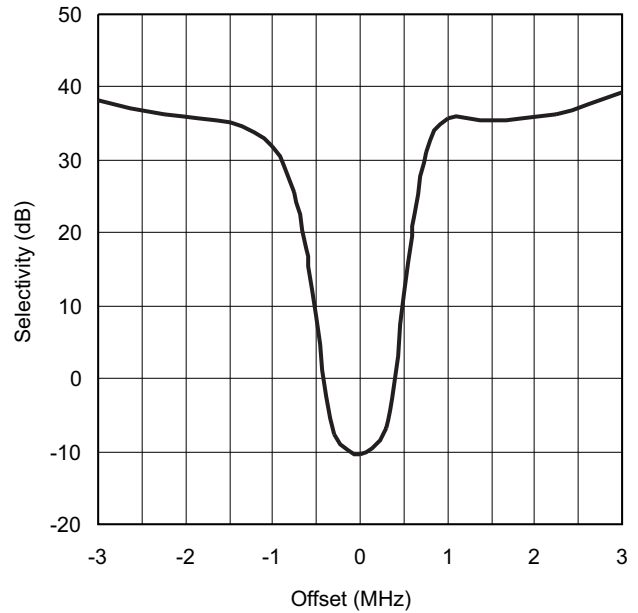
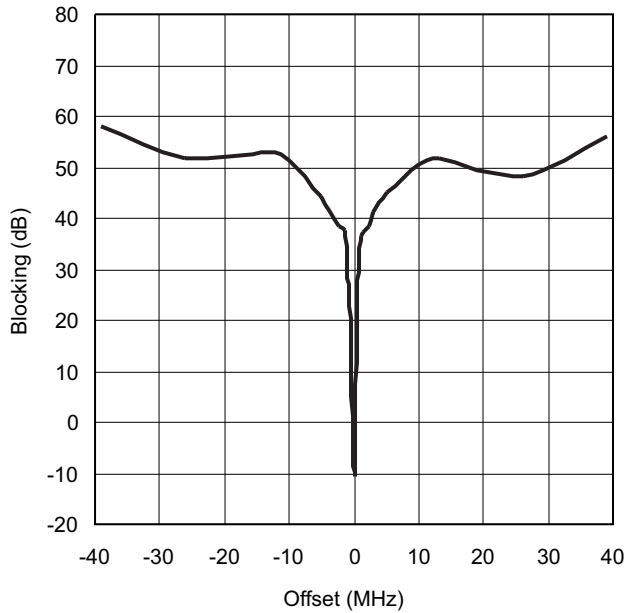

NOTE: 868 MHz, 2-FSK, IF is 304 kHz, digital channel filter bandwidth is 540 kHz

Figure 5-23. Typical Selectivity at 250-kBaud Data Rate

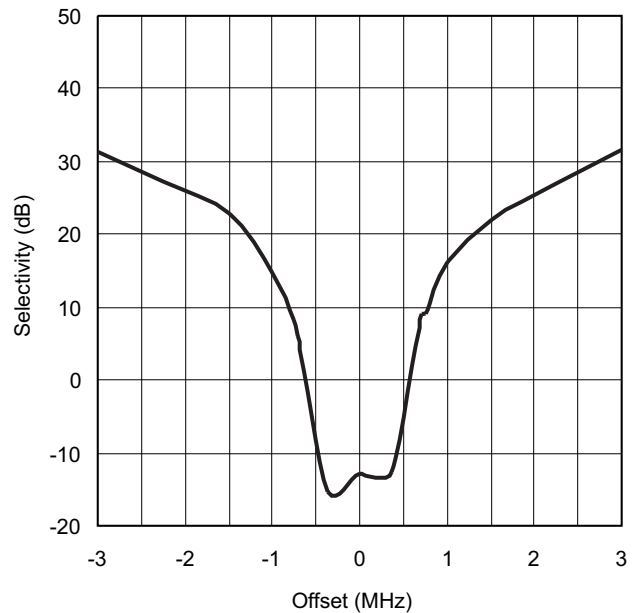
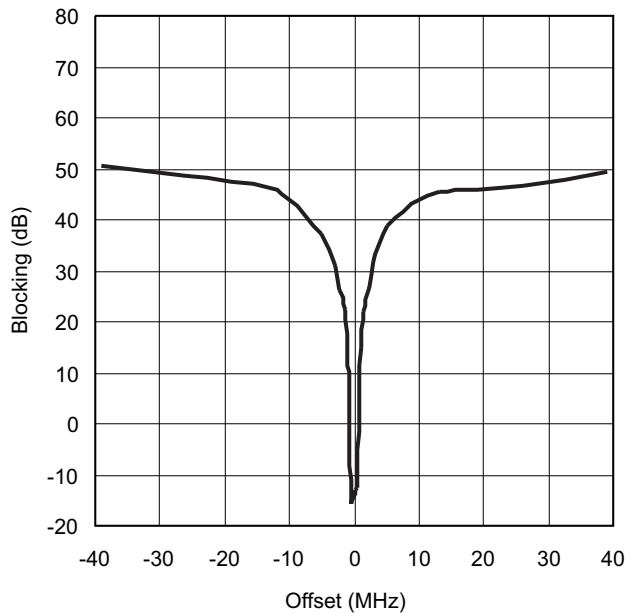

NOTE: 868 MHz, 2-FSK, IF is 355 kHz, digital channel filter bandwidth is 812 kHz

Figure 5-24. Typical Selectivity at 500-kBaud Data Rate

5.59 Typical Sensitivity, 315 MHz, Sensitivity Optimized Setting

PARAMETER	DATA RATE (kBaud)	V _{CC}	2 V			3 V			3.6 V			UNIT
		T _A	-40°C	25°C	85°C	-40°C	25°C	85°C	-40°C	25°C	85°C	
Sensitivity, 315 MHz	1.2		-112	-112	-110	-112	-111	-109	-112	-111	-108	dBm
	38.4		-105	-105	-104	-105	-103	-102	-105	-104	-102	
	250		-95	-95	-92	-94	-95	-92	-95	-94	-91	

5.60 Typical Sensitivity, 433 MHz, Sensitivity Optimized Setting

PARAMETER	DATA RATE (kBaud)	V _{CC}	2 V			3 V			3.6 V			UNIT
		T _A	-40°C	25°C	85°C	-40°C	25°C	85°C	-40°C	25°C	85°C	
Sensitivity, 433 MHz	1.2		-111	-110	-108	-111	-111	-108	-111	-110	-107	dBm
	38.4		-104	-104	-101	-104	-104	-101	-104	-103	-101	
	250		-93	-94	-91	-93	-93	-90	-93	-93	-90	

5.61 Typical Sensitivity, 868 MHz, Sensitivity Optimized Setting

PARAMETER	DATA RATE (kBaud)	V _{CC}	2 V			3 V			3.6 V			UNIT
		T _A	-40°C	25°C	85°C	-40°C	25°C	85°C	-40°C	25°C	85°C	
Sensitivity, 868 MHz	1.2		-109	-109	-107	-109	-109	-106	-109	-108	-106	dBm
	38.4		-102	-102	-100	-102	-102	-99	-102	-101	-99	
	250		-90	-90	-88	-89	-90	-87	-89	-90	-87	
	500		-84	-84	-81	-84	-84	-80	-84	-84	-80	

5.62 Typical Sensitivity, 915 MHz, Sensitivity Optimized Setting

PARAMETER	DATA RATE (kBaud)	V _{CC}	2 V			3 V			3.6 V			UNIT
		T _A	-40°C	25°C	85°C	-40°C	25°C	85°C	-40°C	25°C	85°C	
Sensitivity, 915 MHz	1.2		-109	-109	-107	-109	-109	-106	-109	-108	-105	dBm
	38.4		-102	-102	-100	-102	-102	-99	-103	-102	-99	
	250		-92	-92	-89	-92	-92	-88	-92	-92	-88	
	500		-87	-86	-81	-86	-86	-81	-86	-85	-80	

5.63 RF Transmit

$T_A = 25^\circ\text{C}$, $V_{CC} = 3\text{ V}$ (unless otherwise noted)⁽¹⁾

$P_{TX} = +10\text{ dBm}$ (unless otherwise noted)

PARAMETER	FREQUENCY (MHz)	TEST CONDITIONS		TYP	UNIT		
Differential load impedance ⁽²⁾	315			122 + j31	Ω		
	433			116 + j41			
	868, 915			86.5 + j43			
Output power, highest setting ⁽³⁾	315	Delivered to a 50-Ω single-ended load from CC430 reference design RF matching network		+12	dBm		
	433			+13			
	868			+11			
	915			+11			
Output power, lowest setting ⁽³⁾		Delivered to a 50-Ω single-ended load from CC430 reference design RF matching network		-30	dBm		
Harmonics, radiated ⁽⁴⁾⁽⁵⁾⁽⁶⁾	433	Second harmonic		-56	dBm		
		Third harmonic		-57			
	868	Second harmonic		-50			
		Third harmonic		-52			
	915	Second harmonic		-50			
		Third harmonic		-54			
Harmonics, conducted	315	Frequencies below 960 MHz	+10 dBm CW	< -38	dBm		
		Frequencies above 960 MHz		< -48			
	433	Frequencies below 1 GHz	+10 dBm CW	-45			
		Frequencies above 1 GHz		< -48			
	868	Second harmonic	+10 dBm CW	-59			
		Other harmonics		< -71			
	915	Second harmonic	+11 dBm CW ⁽⁷⁾	-53			
		Other harmonics		< -47			
	Spurious emissions, conducted, harmonics not included ⁽⁸⁾	315	Frequencies below 960 MHz	+10 dBm CW		< -58	dBm
			Frequencies above 960 MHz			< -53	
433		Frequencies below 1 GHz	+10 dBm CW	< -54			
		Frequencies above 1 GHz		< -54			
		Frequencies from 47 to 74, 87.5 to 118, 174 to 230, 470 to 862 MHz		< -63			
868		Frequencies below 1 GHz	+10 dBm CW	< -46			
		Frequencies above 1 GHz		< -59			
		Frequencies from 47 to 74, 87.5 to 118, 174 to 230, 470 to 862 MHz		< -56			
915		Frequencies below 960 MHz	+11 dBm CW	< -49			
		Frequencies above 960 MHz		< -63			
TX latency ⁽⁹⁾		Serial operation		8	bits		

- (1) All measurement results are obtained using the EM430F6137RF900 with BOM according to tested frequency range (see [Table 7-1](#)).
- (2) Differential impedance as seen from the RF port (RF_P and RF_N) towards the antenna. Follow the CC430 reference designs available from the TI website.
- (3) Output power is programmable, and the full range is available in all frequency bands. Output power may be restricted by regulatory limits. Also see [AN050 Using the CC1101 in the European 868MHz SRD Band](#) and [DN013 Programming Output Power on CC1101](#), which gives the output power and harmonics when using multilayer inductors. The output power is then typically +10 dBm when operating at 868 or 915 MHz.
- (4) The antennas used during the radiated measurements (SMAFF-433 from R.W.Badland and Nearson S331 868/915) play a part in attenuating the harmonics.
- (5) Measured on EM430F6137RF900 with CW, maximum output power
- (6) All harmonics are below -41.2 dBm when operating in the 902 to 928 MHz band.
- (7) Requirement is -20 dBc under FCC 15.247.
- (8) All radiated spurious emissions are within the limits of ETSI. Also see [DN017 CC11xx 868/915 MHz RF Matching](#).
- (9) Time from sampling the data on the transmitter data input pin until it is observed on the RF output ports

5.64 Optimum PATABLE Settings for Various Output Power Levels and Frequency Bands

$T_A = 25^\circ\text{C}$, $V_{CC} = 3\text{ V}$ (unless otherwise noted)⁽¹⁾

OUTPUT POWER (dBm)	PATABLE SETTING			
	315 MHz	433 MHz	868 MHz	915 MHz
-30	0x12	0x05	0x03	0x03
-12	0x33	0x26	0x25	0x25
-6	0x29	0x2D	0x2D	0x2D
0	0x51	0x50	0x8D	0x8D
10	0xC4	0xC4	0xC3	0xC3
Maximum	0xC0	0xC0	0xC0	0xC0

(1) All measurement results are obtained using the EM430F6137RF900 with BOM according to tested frequency range (see [Table 7-1](#)).

5.65 Typical Output Power, 315 MHz⁽¹⁾

PARAMETER	PATABLE SETTING	V _{CC}	2 V	3 V	3.6 V	UNIT
		T _A	25°C	25°C	25°C	
Output power, 315 MHz	0xC0 (maximum)		11.9	11.8	11.8	dBm
	0xC4 (10 dBm)		10.3	10.3	10.3	
	0xC6 (default)			9.3		
	0x51 (0 dBm)		0.7	0.6	0.7	
	0x29 (-6 dBm)		-6.8	-5.6	-5.3	

(1) All measurement results are obtained using the EM430F6137RF900 with BOM according to tested frequency range (see [Table 7-1](#)).

5.66 Typical Output Power, 433 MHz⁽¹⁾

PARAMETER	PATABLE SETTING	V _{CC}	2 V	3 V	3.6 V	UNIT
		T _A	25°C	25°C	25°C	
Output power, 433 MHz	0xC0 (maximum)		12.6	12.6	12.6	dBm
	0xC4 (10 dBm)		10.3	10.2	10.2	
	0xC6 (default)			10.0		
	0x50 (0 dBm)		0.3	0.3	0.3	
	0x2D (-6 dBm)		-6.4	-5.4	-5.1	

(1) All measurement results are obtained using the EM430F6137RF900 with BOM according to tested frequency range (see [Table 7-1](#)).

5.67 Typical Output Power, 868 MHz⁽¹⁾

PARAMETER	PATABLE SETTING	V _{CC}	2 V			3 V			3.6 V			UNIT
		T _A	-40°C	25°C	85°C	-40°C	25°C	85°C	-40°C	25°C	85°C	
Output power, 868 MHz	0xC0 (maximum)		11.9	11.2	10.5	11.9	11.2	10.5	11.9	11.2	10.5	dBm
	0xC3 (10 dBm)		10.8	10.1	9.4	10.8	10.1	9.4	10.7	10.1	9.4	
	0xC6 (default)						8.8					
	0x8D (0 dBm)		1.0	0.3	-0.3	1.1	0.3	-0.3	1.1	0.3	-0.3	
	0x2D (-6 dBm)		-6.5	-6.8	-7.3	-5.3	-5.8	-6.3	-4.9	-5.4	-6.0	

(1) All measurement results are obtained using the EM430F6137RF900 with BOM according to tested frequency range (see [Table 7-1](#)).

5.68 Typical Output Power, 915 MHz⁽¹⁾

PARAMETER	PATABLE SETTING	V _{CC}	2 V			3 V			3.6 V			UNIT
		T _A	-40°C	25°C	85°C	-40°C	25°C	85°C	-40°C	25°C	85°C	
Output power, 915 MHz	0xC0 (maximum)		12.2	11.4	10.6	12.1	11.4	10.7	12.1	11.4	10.7	dBm
	0xC3 (10 dBm)		11.0	10.3	9.5	11.0	10.3	9.5	11.0	10.3	9.6	
	0xC6 (default)						8.8					
	0x8D (0 dBm)		1.9	1.0	0.3	1.9	1.0	0.3	1.9	1.1	0.3	
	0x2D (-6 dBm)		-5.5	-6.0	-6.5	-4.3	-4.8	-5.5	-3.9	-4.4	-5.1	

(1) All measurement results are obtained using the EM430F6137RF900 with BOM according to tested frequency range (see [Table 7-1](#)).

5.69 Frequency Synthesizer Characteristics

$T_A = 25^\circ\text{C}$, $V_{CC} = 3\text{ V}$ (unless otherwise noted)⁽¹⁾

MIN figures are given using a 27MHz crystal. TYP and MAX figures are given using a 26MHz crystal.

PARAMETER	TEST CONDITIONS	MIN	TYP	MAX	UNIT
Programmed frequency resolution ⁽²⁾	26- to 27-MHz crystal	397	$f_{XOSC} / 2^{16}$	412	Hz
Synthesizer frequency tolerance ⁽³⁾			±40		ppm
RF carrier phase noise	50-kHz offset from carrier		-95		dBc/Hz
	100-kHz offset from carrier		-94		
	200-kHz offset from carrier		-94		
	500-kHz offset from carrier		-98		
	1-MHz offset from carrier		-107		
	2-MHz offset from carrier		-112		
	5-MHz offset from carrier		-118		
	10-MHz offset from carrier		-129		
PLL turnon and hop time ⁽⁴⁾	Crystal oscillator running	85.1	88.4	88.4	µs
PLL RX to TX settling time ⁽⁵⁾		9.3	9.6	9.6	µs
PLL TX to RX settling time ⁽⁶⁾		20.7	21.5	21.5	µs
PLL calibration time ⁽⁷⁾		694	721	721	µs

(1) All measurement results are obtained using the EM430F6137RF900 with BOM according to tested frequency range (see [Table 7-1](#)).

(2) The resolution (in Hz) is equal for all frequency bands.

(3) Depends on crystal used. Required accuracy (including temperature and aging) depends on frequency band and channel bandwidth and spacing.

(4) Time from leaving the IDLE state until arriving in the RX, FSTXON, or TX state, when not performing calibration.

(5) Settling time for the 1-IF step from RX to TX

(6) Settling time for the 1-IF step from TX to RX

(7) Calibration can be initiated manually or automatically before entering or after leaving RX or TX.

5.70 Typical RSSI_offset Values

$T_A = 25^\circ\text{C}$, $V_{CC} = 3\text{ V}$ (unless otherwise noted)⁽¹⁾

DATA RATE (kBaud)	RSSI_OFFSET (dB)	
	433 MHz	868 MHz
1.2	74	74
38.4	74	74
250	74	74
500	74	74

(1) All measurement results are obtained using the EM430F6137RF900 with BOM according to tested frequency range (see Table 7-1).

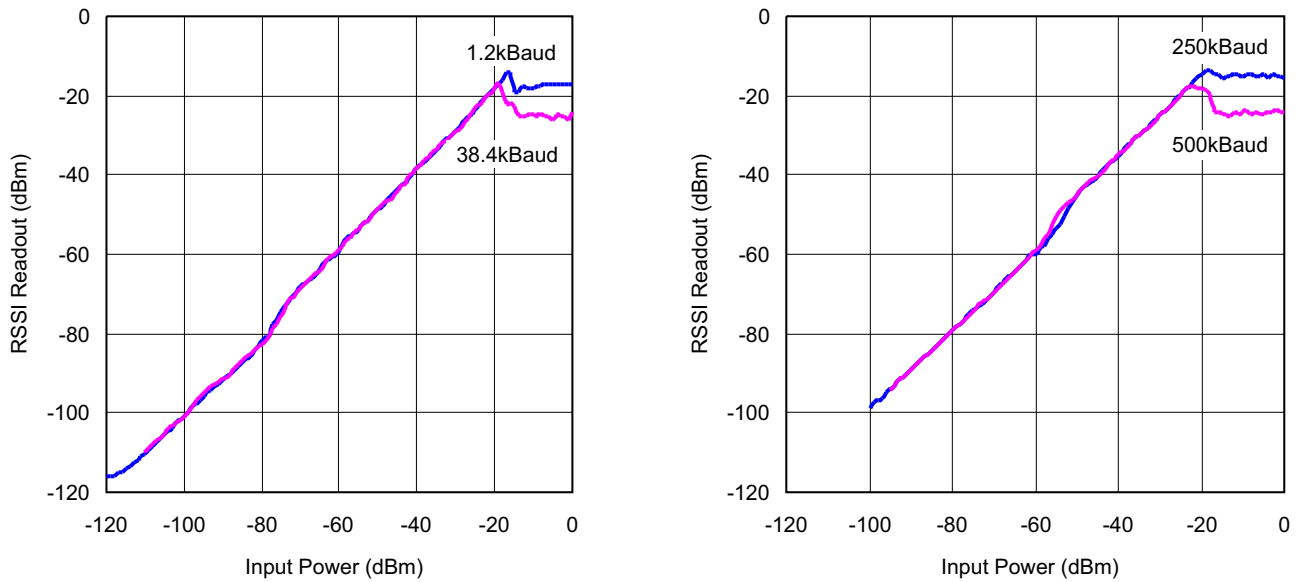
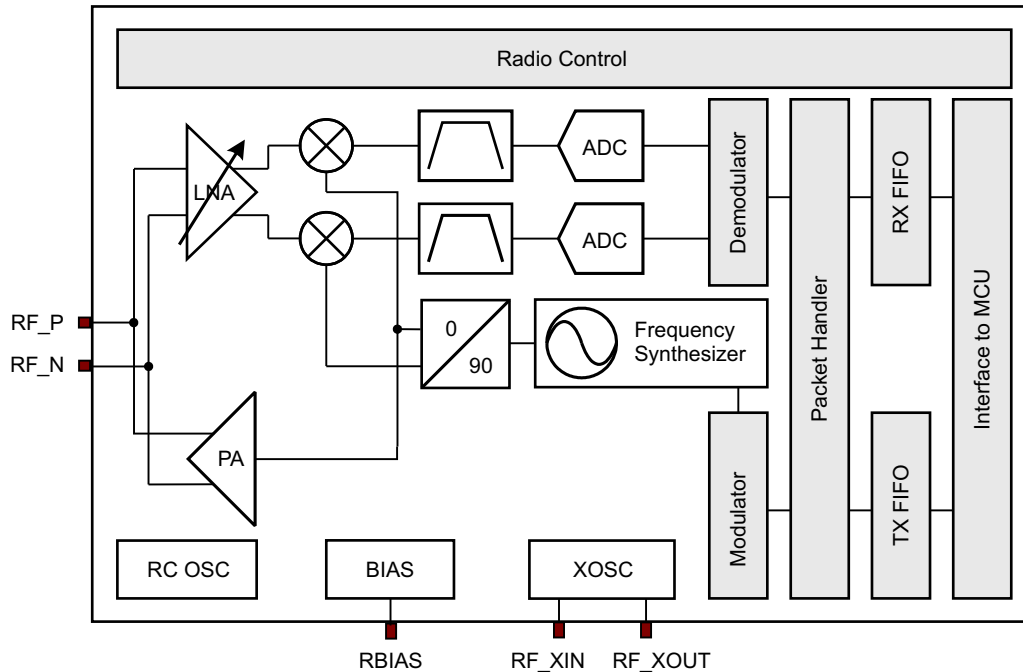

Figure 5-25. Typical RSSI Value vs Input Power Level for Different Data Rates at 868 MHz

6 Detailed Description

6.1 Sub-1 GHz Radio

The implemented sub-1 GHz radio module is based on the industry-leading CC1101, requiring very few external components. [Figure 6-1](#) shows a high-level block diagram of the implemented radio.



Copyright © 2017, Texas Instruments Incorporated

Figure 6-1. Sub-1 GHz Radio Block Diagram

The radio features a low-IF receiver. The received RF signal is amplified by a low-noise amplifier (LNA) and down-converted in quadrature to the intermediate frequency (IF). At IF, the I/Q signals are digitized. Automatic gain control (AGC), fine channel filtering, demodulation bit, and packet synchronization are performed digitally.

The transmitter part is based on direct synthesis of the RF. The frequency synthesizer includes a completely on-chip LC VCO and a 90° phase shifter for generating the I and Q LO signals to the down-conversion mixers in receive mode.

The 26-MHz crystal oscillator generates the reference frequency for the synthesizer, as well as clocks for the ADC and the digital part.

A memory mapped register interface is used for data access, configuration, and status request by the CPU.

The digital baseband includes support for channel configuration, packet handling, and data buffering.

For complete module descriptions, see the [CC430 Family User's Guide](#).

6.2 CPU

The MSP430 CPU has a 16-bit RISC architecture that is highly transparent to the application. All operations, other than program-flow instructions, are performed as register operations in conjunction with seven addressing modes for source operand and four addressing modes for destination operand.

The CPU is integrated with 16 registers that provide reduced instruction execution time. The register-to-register operation execution time is one cycle of the CPU clock.

Four of the registers, R0 to R3, are dedicated as program counter, stack pointer, status register, and constant generator, respectively. The remaining registers are general-purpose registers.

Peripherals are connected to the CPU using data, address, and control buses. The peripherals can be managed with all instructions.

The instruction set consists of the original 51 instructions with three formats and seven address modes and additional instructions for the expanded address range. Each instruction can operate on word and byte data.

6.3 Operating Modes

The CC430 has one active mode and five software-selectable low-power modes of operation. An interrupt event can wake up the device from any of the low-power modes, service the request, and restore back to the low-power mode on return from the interrupt program.

Software can configure the following operating modes:

- Active mode (AM)
 - All clocks are active
- Low-power mode 0 (LPM0)
 - CPU is disabled
 - ACLK and SMCLK remain active, MCLK is disabled
 - FLL loop control remains active
- Low-power mode 1 (LPM1)
 - CPU is disabled
 - FLL loop control is disabled
 - ACLK and SMCLK remain active, MCLK is disabled
- Low-power mode 2 (LPM2)
 - CPU is disabled
 - MCLK and FLL loop control and DCOCLK are disabled
 - DC generator of the DCO remains enabled
 - ACLK remains active
- Low-power mode 3 (LPM3)
 - CPU is disabled
 - MCLK, FLL loop control, and DCOCLK are disabled
 - DC generator of the DCO is disabled
 - ACLK remains active
- Low-power mode 4 (LPM4)
 - CPU is disabled
 - ACLK is disabled
 - MCLK, FLL loop control, and DCOCLK are disabled
 - DC generator of the DCO is disabled
 - Crystal oscillator is stopped
 - Complete data retention

6.4 Interrupt Vector Addresses

The interrupt vectors and the power-up start address are located in the address range 0FFFFh–0FF80h (see Table 6-1). The vector contains the 16-bit address of the appropriate interrupt-handler instruction sequence.

asd

Table 6-1. Interrupt Sources, Flags, and Vectors

INTERRUPT SOURCE	INTERRUPT FLAG	SYSTEM INTERRUPT	WORD ADDRESS	PRIORITY
System Reset Power-Up External Reset Watchdog Time-out, Password Violation Flash Memory Password Violation	WDTIFG, KEYV (SYSRSTIV) ⁽¹⁾⁽²⁾	Reset	0FFFEh	63, highest
System NMI PMM Vacant Memory Access JTAG Mailbox	SVMLIFG, SVMHIFG, DLYLIFG, DLYHIFG, VLRLIFG, VLRHIFG, VMAIFG, JMBNIFG, JMBOUTIFG (SYSSNIV) ⁽¹⁾⁽³⁾	(Non)maskable	0FFFCCh	62
User NMI NMI Oscillator Fault Flash Memory Access Violation	NMIIFG, OFIFG, ACCVIFG (SYSUNIV) ⁽¹⁾⁽³⁾	(Non)maskable	0FFFAh	61
Comparator_B	Comparator_B Interrupt Flags (CBIV) ⁽¹⁾	Maskable	0FFF8h	60
Watchdog Interval Timer Mode	WDTIFG	Maskable	0FFF6h	59
USCI_A0 Receive or Transmit	UCA0RXIFG, UCA0TXIFG (UCA0IV) ⁽¹⁾	Maskable	0FFF4h	58
USCI_B0 Receive or Transmit	UCB0RXIFG, UCB0TXIFG, I ² C Status Interrupt Flags (UCB0IV) ⁽¹⁾	Maskable	0FFF2h	57
ADC12_A (Reserved on CC430F612x)	ADC12IFG0 ... ADC12IFG15 (ADC12IV) ⁽¹⁾	Maskable	0FFF0h	56
TA0	TA0CCR0 CCIFG0	Maskable	0FFEEh	55
TA0	TA0CCR1 CCIFG1 ... TA0CCR4 CCIFG4, TA0IFG (TA0IV) ⁽¹⁾	Maskable	0FFECCh	54
RF1A CC1101-based Radio	Radio Interface Interrupt Flags (RF1AIFIV) Radio Core Interrupt Flags (RF1AIV)	Maskable	0FFEAh	53
DMA	DMA0IFG, DMA1IFG, DMA2IFG (DMAIV) ⁽¹⁾	Maskable	0FFE8h	52
TA1	TA1CCR0 CCIFG0	Maskable	0FFE6h	51
TA1	TA1CCR1 CCIFG1 ... TA1CCR2 CCIFG2, TA1IFG (TA1IV) ⁽¹⁾	Maskable	0FFE4h	50
I/O Port P1	P1IFG.0 to P1IFG.7 (P1IV) ⁽¹⁾	Maskable	0FFE2h	49
I/O Port P2	P2IFG.0 to P2IFG.7 (P2IV) ⁽¹⁾	Maskable	0FFE0h	48
LCD_B (Reserved on CC430F513x)	LCD_B Interrupt Flags (LCDBIV) ⁽¹⁾	Maskable	0FFDEh	47
RTC_A	RTCRDYIFG, RTCTEVIFG, RTCAIFG, RT0PSIFG, RT1PSIFG (RTCIV) ⁽¹⁾	Maskable	0FFDCh	46
AES	AESRDYIFG	Maskable	0FFDAh	45
Reserved	Reserved ⁽⁴⁾		0FFD8h	44
			⋮	⋮
			0FF80h	0, lowest

(1) Multiple source flags

(2) A reset is generated if the CPU tries to fetch instructions from within peripheral space.

(3) (Non)maskable: the individual interrupt-enable bit can disable an interrupt event, but the general-interrupt enable cannot disable it.

(4) Reserved interrupt vectors at addresses are not used in this device and can be used for regular program code if necessary. To maintain compatibility with other devices, reserve these locations.

6.5 Memory Organization

Table 6-2 summarizes the memory map of the devices.

Table 6-2. Memory Organization

		CC430F6137 CC430F6127 CC430F5137 ⁽¹⁾	CC430F6126 ⁽¹⁾	CC430F6135 CC430F6125 CC430F5135 ⁽¹⁾	CC430F5133 ⁽¹⁾
Main Memory (flash)	Total Size	32KB	32KB	16KB	8KB
	Main: Interrupt vector	00FFFFh–00FF80h	00FFFFh–00FF80h	00FFFFh–00FF80h	00FFFFh–00FF80h
	Main: code memory	Bank 0 32KB 00FFFFh–008000h	32KB 00FFFFh–008000h	16KB 00FFFFh–00C000h	8KB 00FFFFh–00E000h
RAM	Total Size	4KB	2KB	2KB	2KB
	Sect 1	2KB 002BFFh–002400h	not available	not available	not available
	Sect 0	2KB 0023FFh–001C00h	2KB 0023FFh–001C00h	2KB 0023FFh–001C00h	2KB 0023FFh–001C00h
Device Descriptor		128 B 001AFFh–001A80h	128 B 001AFFh–001A80h	128 B 001AFFh–001A80h	128 B 001AFFh–001A80h
		128 B 001A7Fh–001A00h	128 B 001A7Fh–001A00h	128 B 001A7Fh–001A00h	128 B 001A7Fh–001A00h
Information memory (flash)	Info A	128 B 0019FFh–001980h	128 B 0019FFh–001980h	128 B 0019FFh–001980h	128 B 0019FFh–001980h
	Info B	128 B 00197Fh–001900h	128 B 00197Fh–001900h	128 B 00197Fh–001900h	128 B 00197Fh–001900h
	Info C	128 B 0018FFh–001880h	128 B 0018FFh–001880h	128 B 0018FFh–001880h	128 B 0018FFh–001880h
	Info D	128 B 00187Fh–001800h	128 B 00187Fh–001800h	128 B 00187Fh–001800h	128 B 00187Fh–001800h
Bootloader (BSL) memory (flash)	BSL 3	512 B 0017FFh–001600h	512 B 0017FFh–001600h	512 B 0017FFh–001600h	512 B 0017FFh–001600h
	BSL 2	512 B 0015FFh–001400h	512 B 0015FFh–001400h	512 B 0015FFh–001400h	512 B 0015FFh–001400h
	BSL 1	512 B 0013FFh–001200h	512 B 0013FFh–001200h	512 B 0013FFh–001200h	512 B 0013FFh–001200h
	BSL 0	512 B 0011FFh–001000h	512 B 0011FFh–001000h	512 B 0011FFh–001000h	512 B 0011FFh–001000h
Peripherals	4KB 000FFFh–0h	4KB 000FFFh–0h	4KB 000FFFh–0h	4KB 000FFFh–0h	

(1) All memory regions not specified here are vacant memory, and any access to them causes a Vacant Memory Interrupt.

6.6 Bootloader (BSL)

The BSL enables users to program the flash memory or RAM using various serial interfaces. [Table 6-3](#) lists the pin requirements. Access to the device memory through the BSL is protected by a user-defined password. BSL entry requires a specific entry sequence on the $\overline{\text{RST}}/\text{NMI}/\text{SBWTDIO}$ and $\text{TEST}/\text{SBWTCK}$ pins. For a complete description of the features of the BSL and its implementation, see [MSP430 Programming With the Bootloader \(BSL\)](#).

Table 6-3. UART BSL Pin Requirements and Functions

DEVICE SIGNAL	BSL FUNCTION
$\overline{\text{RST}}/\text{NMI}/\text{SBWTDIO}$	Entry sequence signal
$\text{TEST}/\text{SBWTCK}$	Entry sequence signal
P1.6	Data transmit
P1.5	Data receive
VCC	Power supply
VSS	Ground supply

6.7 JTAG Operation

6.7.1 JTAG Standard Interface

The CC430 family supports the standard JTAG interface which requires four signals for sending and receiving data. The JTAG signals are shared with general-purpose I/O. The $\text{TEST}/\text{SBWTCK}$ pin is used to enable the JTAG signals. In addition to these signals, the $\overline{\text{RST}}/\text{NMI}/\text{SBWTDIO}$ is required to interface with MSP430 development tools and device programmers. [Table 6-4](#) lists the JTAG pin requirements. For further details on interfacing to development tools and device programmers, see the [MSP430 Hardware Tools User's Guide](#). For a complete description of the features of the JTAG interface and its implementation, see [MSP430 Programming With the JTAG Interface](#).

Table 6-4. JTAG Pin Requirements and Functions

DEVICE SIGNAL	DIRECTION	FUNCTION
PJ.3/TCK	IN	JTAG clock input
PJ.2/TMS	IN	JTAG state control
PJ.1/TDI/TCLK	IN	JTAG data input, TCLK input
PJ.0/TDO	OUT	JTAG data output
$\text{TEST}/\text{SBWTCK}$	IN	Enable JTAG pins
$\overline{\text{RST}}/\text{NMI}/\text{SBWTDIO}$	IN	External reset
VCC		Power supply
VSS		Ground supply

6.7.2 Spy-Bi-Wire Interface

In addition to the standard JTAG interface, the CC430 family supports the two wire Spy-Bi-Wire interface. Spy-Bi-Wire can be used to interface with MSP430 development tools and device programmers. [Table 6-5](#) lists the Spy-Bi-Wire interface pin requirements. For further details on interfacing to development tools and device programmers, see the [MSP430 Hardware Tools User's Guide](#). For a complete description of the features of the JTAG interface and its implementation, see [MSP430 Programming With the JTAG Interface](#).

Table 6-5. Spy-Bi-Wire Pin Requirements and Functions

DEVICE SIGNAL	DIRECTION	FUNCTION
TEST/SBWTCK	IN	Spy-Bi-Wire clock input
$\overline{\text{RST}}$ /NMI/SBWDIO	IN, OUT	Spy-Bi-Wire data input/output
VCC		Power supply
VSS		Ground supply

6.8 Flash Memory

The flash memory can be programmed through the JTAG port, Spy-Bi-Wire (SBW), or in-system by the CPU. The CPU can perform single-byte, single-word, and long-word writes to the flash memory. Features of the flash memory include:

- Flash memory has n segments of main memory and four segments of information memory (Info A to Info D) of 128 bytes each. Each segment in main memory is 512 bytes in size.
- Segments 0 to n may be erased in one step, or each segment may be individually erased.
- Segments Info A to Info D can be erased individually, or as a group with the main memory segments. Segments Info A to Info D are also called *information memory*.
- Segment A can be locked separately.

6.9 RAM

The RAM is made up of n sectors. Each sector can be completely powered down to save leakage; however, all data are lost. Features of the RAM include:

- RAM has n sectors of 2KB each.
- Each sector 0 to n can be completely disabled; however, data retention is lost.
- Each sector 0 to n automatically enters low power retention mode when possible.

6.10 Peripherals

Peripherals are connected to the CPU through data, address, and control buses. The peripherals can be managed using all instructions. For complete module descriptions, see the [CC430 Family User's Guide](#).

6.10.1 Oscillator and System Clock

The Unified Clock System (UCS) module includes support for a 32768-Hz watch crystal oscillator, an internal very-low-power low-frequency oscillator (VLO), an internal trimmed low-frequency oscillator (REFO), an integrated internal digitally controlled oscillator (DCO), and a high-frequency crystal oscillator. The UCS module is designed to meet the requirements of both low system cost and low-power consumption. The UCS module features digital frequency locked loop (FLL) hardware that, in conjunction with a digital modulator, stabilizes the DCO frequency to a programmable multiple of the watch crystal frequency. The internal DCO provides a fast turnon clock source and stabilizes in less than 5 μ s. The UCS module provides the following clock signals:

- Auxiliary clock (ACLK), sourced from a 32768-Hz watch crystal, a high-frequency crystal, the internal low-frequency oscillator (VLO), or the trimmed low-frequency oscillator (REFO).
- Main clock (MCLK), the system clock used by the CPU. MCLK can be sourced by same sources made available to ACLK.
- Sub-Main clock (SMCLK), the subsystem clock used by the peripheral modules. SMCLK can be sourced by same sources made available to ACLK.
- ACLK/n, the buffered output of ACLK, ACLK/2, ACLK/4, ACLK/8, ACLK/16, ACLK/32.

6.10.2 Power-Management Module (PMM)

The PMM includes an integrated voltage regulator that supplies the core voltage to the device and contains programmable output levels to provide for power optimization. The PMM also includes supply voltage supervisor (SVS) and supply voltage monitoring (SVM) circuitry, as well as brownout protection. The brownout circuit is implemented to provide the proper internal reset signal to the device during power-on and power-off. The SVS/SVM circuitry detects if the supply voltage drops below a user-selectable level and supports both supply voltage supervision (the device is automatically reset) and supply voltage monitoring (the device is not automatically reset). SVS and SVM circuitry is available on the primary supply and core supply.

6.10.3 Digital I/O

Up to five 8-bit I/O ports are implemented: ports P1 through P5.

- All individual I/O bits are independently programmable.
- Any combination of input, output, and interrupt conditions is possible.
- Programmable pullup or pulldown on all ports.
- Programmable drive strength on all ports.
- Edge-selectable interrupt input capability for all the eight bits of ports P1 and P2.
- Read and write access to port-control registers is supported by all instructions.
- Ports can be accessed byte-wise (P1 through P5) or word-wise in pairs (PA and PB).

6.10.4 Port Mapping Controller

The port mapping controller allows the flexible and reconfigurable mapping of digital functions to port pins of ports P1 through P3 (see Table 6-6). Table 6-7 lists the default settings for all pins that support port mapping.

Table 6-6. Port Mapping, Mnemonics and Functions

VALUE	PxMAPy MNEMONIC	INPUT PIN FUNCTION (PxDIR.y = 0)	OUTPUT PIN FUNCTION (PxDIR.y = 1)
0	PM_NONE	None	DVSS
1 ⁽¹⁾	PM_CBOU0	–	Comparator_B output (on TA0 clock input)
	PM_TA0CLK	TA0 clock input	–
2 ⁽¹⁾	PM_CBOU1	–	Comparator_B output (on TA1 clock input)
	PM_TA1CLK	TA1 clock input	–
3	PM_ACLK	None	ACLK output
4	PM_MCLK	None	MCLK output
5	PM_SMCLK	None	SMCLK output
6	PM_RTCCLK	None	RTCCLK output
7 ⁽¹⁾	PM_ADC12CLK	–	ADC12CLK output
	PM_DMAE0	DMA external trigger input	–
8	PM_SVMOUT	None	SVM output
9	PM_TA0CCR0A	TA0 CCR0 capture input CCI0A	TA0 CCR0 compare output Out0
10	PM_TA0CCR1A	TA0 CCR1 capture input CCI1A	TA0 CCR1 compare output Out1
11	PM_TA0CCR2A	TA0 CCR2 capture input CCI2A	TA0 CCR2 compare output Out2
12	PM_TA0CCR3A	TA0 CCR3 capture input CCI3A	TA0 CCR3 compare output Out3
13	PM_TA0CCR4A	TA0 CCR4 capture input CCI4A	TA0 CCR4 compare output Out4
14	PM_TA1CCR0A	TA1 CCR0 capture input CCI0A	TA1 CCR0 compare output Out0
15	PM_TA1CCR1A	TA1 CCR1 capture input CCI1A	TA1 CCR1 compare output Out1
16	PM_TA1CCR2A	TA1 CCR2 capture input CCI2A	TA1 CCR2 compare output Out2
17 ⁽²⁾	PM_UCA0RXD	USCI_A0 UART RXD (direction controlled by USCI – input)	
	PM_UCA0SOMI	USCI_A0 SPI slave out master in (direction controlled by USCI)	
18 ⁽²⁾	PM_UCA0TXD	USCI_A0 UART TXD (direction controlled by USCI – output)	
	PM_UCA0SIMO	USCI_A0 SPI slave in master out (direction controlled by USCI)	
19 ⁽³⁾	PM_UCA0CLK	USCI_A0 clock input/output (direction controlled by USCI)	
	PM_UCB0STE	USCI_B0 SPI slave transmit enable (direction controlled by USCI – input)	
20 ⁽⁴⁾	PM_UCB0SOMI	USCI_B0 SPI slave out master in (direction controlled by USCI)	
	PM_UCB0SCL	USCI_B0 I ² C clock (open drain and direction controlled by USCI)	
21 ⁽⁴⁾	PM_UCB0SIMO	USCI_B0 SPI slave in master out (direction controlled by USCI)	
	PM_UCB0SDA	USCI_B0 I ² C data (open drain and direction controlled by USCI)	
22 ⁽⁵⁾	PM_UCB0CLK	USCI_B0 clock input/output (direction controlled by USCI)	
	PM_UCA0STE	USCI_A0 SPI slave transmit enable (direction controlled by USCI – input)	
23	PM_RFGDO0	Radio GDO0 (direction controlled by Radio)	
24	PM_RFGDO1	Radio GDO1 (direction controlled by Radio)	
25	PM_RFGDO2	Radio GDO2 (direction controlled by Radio)	

- (1) Input or output function is selected by the corresponding setting in the port direction register PxDIR.
- (2) UART or SPI functionality is determined by the selected USCI mode.
- (3) UCA0CLK function takes precedence over UCB0STE function. If the mapped pin is required as UCA0CLK input or output, USCI_B0 is forced to 3-wire SPI mode even if 4-wire mode is selected.
- (4) SPI or I²C functionality is determined by the selected USCI mode. In case the I²C functionality is selected the output of the mapped pin drives only the logical 0 to V_{SS} level.
- (5) UCB0CLK function takes precedence over UCA0STE function. If the mapped pin is required as UCB0CLK input or output, USCI_A0 is forced to 3-wire SPI mode even if 4-wire mode is selected.

Table 6-6. Port Mapping, Mnemonics and Functions (continued)

VALUE	PxMAPy MNEMONIC	INPUT PIN FUNCTION (PxDIR.y = 0)	OUTPUT PIN FUNCTION (PxDIR.y = 1)
26	Reserved	None	DVSS
27	Reserved	None	DVSS
28	Reserved	None	DVSS
29	Reserved	None	DVSS
30	Reserved	None	DVSS
31 (0FFh) ⁽⁶⁾	PM_ANALOG	Disables the output driver and the input Schmitt-trigger to prevent parasitic cross currents when applying analog signals.	

(6) The value of the PM_ANALOG mnemonic is set to 0FFh. The port mapping registers are only 5 bits wide and the upper bits are ignored, resulting in a read value of 31.

Table 6-7. Default Mapping

PIN	PxMAPy MNEMONIC	INPUT PIN FUNCTION (PxDIR.y = 0)	OUTPUT PIN FUNCTION (PxDIR.y = 1)
P1.0/P1MAP0	PM_RFGDO0	None	Radio GDO0
P1.1/P1MAP1	PM_RFGDO2	None	Radio GDO2
P1.2/P1MAP2	PM_UCB0SOMI/PM_UCB0SCL	USCI_B0 SPI slave out master in (direction controlled by USCI), USCI_B0 I ² C clock (open drain and direction controlled by USCI)	
P1.3/P1MAP3	PM_UCB0SIMO/PM_UCB0SDA	USCI_B0 SPI slave in master out (direction controlled by USCI), USCI_B0 I ² C data (open drain and direction controlled by USCI)	
P1.4/P1MAP4	PM_UCB0CLK/PM_UCA0STE	USCI_B0 clock input/output (direction controlled by USCI), USCI_A0 SPI slave transmit enable (direction controlled by USCI – input)	
P1.5/P1MAP5	PM_UCA0RXD/PM_UCA0SOMI	USCI_A0 UART RXD (direction controlled by USCI – input), USCI_A0 SPI slave out master in (direction controlled by USCI)	
P1.6/P1MAP6	PM_UCA0TXD/PM_UCA0SIMO	USCI_A0 UART TXD (direction controlled by USCI – output), USCI_A0 SPI slave in master out (direction controlled by USCI)	
P1.7/P1MAP7	PM_UCA0CLK/PM_UCB0STE	USCI_A0 clock input/output (direction controlled by USCI), USCI_B0 SPI slave transmit enable (direction controlled by USCI – input)	
P2.0/P2MAP0	PM_CBOU01/PM_TA1CLK	TA1 clock input	Comparator_B output
P2.1/P2MAP1	PM_TA1CCR0A	TA1 CCR0 capture input CCI0A	TA1 CCR0 compare output Out0
P2.2/P2MAP2	PM_TA1CCR1A	TA1 CCR1 capture input CCI1A	TA1 CCR1 compare output Out1
P2.3/P2MAP3	PM_TA1CCR2A	TA1 CCR2 capture input CCI2A	TA1 CCR2 compare output Out2
P2.4/P2MAP4	PM_RTCCLK	None	RTCCLK output
P2.5/P2MAP5	PM_SVMOUT	None	SVM output
P2.6/P2MAP6	PM_ACLK	None	ACLK output
P2.7/P2MAP7	PM_ADC12CLK/PM_DMAE0	DMA external trigger input	ADC12CLK output
P3.0/P3MAP0	PM_CBOU00/PM_TA0CLK	TA0 clock input	Comparator_B output
P3.1/P3MAP1	PM_TA0CCR0A	TA0 CCR0 capture input CCI0A	TA0 CCR0 compare output Out0
P3.2/P3MAP2	PM_TA0CCR1A	TA0 CCR1 capture input CCI1A	TA0 CCR1 compare output Out1
P3.3/P3MAP3	PM_TA0CCR2A	TA0 CCR2 capture input CCI2A	TA0 CCR2 compare output Out2
P3.4/P3MAP4	PM_TA0CCR3A	TA0 CCR3 capture input CCI3A	TA0 CCR3 compare output Out3
P3.5/P3MAP5	PM_TA0CCR4A	TA0 CCR4 capture input CCI4A	TA0 CCR4 compare output Out4
P3.6/P3MAP6	PM_RFGDO1	None	Radio GDO1
P3.7/P3MAP7	PM_SMCLK	None	SMCLK output

6.10.5 System Module (SYS)

The SYS module handles many of the system functions within the device. These functions include power on reset and power up clear handling, NMI source selection and management, reset interrupt vector generators (see Table 6-8), bootloader entry mechanisms, and configuration management (device descriptors). SYS also includes a data exchange mechanism through JTAG called a JTAG mailbox that can be used in the application.

Table 6-8. System Module Interrupt Vector Registers

INTERRUPT VECTOR REGISTER	ADDRESS	INTERRUPT EVENT	VALUE	PRIORITY
SYSRSTIV, System Reset	019Eh	No interrupt pending	00h	
		Brownout (BOR)	02h	Highest
		RST/NMI (POR)	04h	
		PMMSWBOR (BOR)	06h	
		Reserved	08h	
		Security violation (BOR)	0Ah	
		SVSL (POR)	0Ch	
		SVSH (POR)	0Eh	
		SVML_OVP (POR)	10h	
		SVMH_OVP (POR)	12h	
		PMMSWPOR (POR)	14h	
		WDT time-out (PUC)	16h	
		WDT password violation (PUC)	18h	
		KEYV flash password violation (PUC)	1Ah	
		Reserved	1Ch	
		Peripheral area fetch (PUC)	1Eh	
		PMM password violation (PUC)	20h	
Reserved	22h to 3Eh	Lowest		
SYSSNIV, System NMI	019Ch	No interrupt pending	00h	
		SVMLIFG	02h	Highest
		SVMHIFG	04h	
		DLYLIFG	06h	
		DLYHIFG	08h	
		VMAIFG	0Ah	
		JMBINIFG	0Ch	
		JMBOUTIFG	0Eh	
		VLRIFG	10h	
		VLRHIFG	12h	
		Reserved	14h to 1Eh	Lowest
SYSUNIV, User NMI	019Ah	No interrupt pending	00h	
		NMIIFG	02h	Highest
		OFIFG	04h	
		ACCVIFG	06h	
		Reserved	08h to 1Eh	Lowest

6.10.6 DMA Controller

The DMA controller allows movement of data from one memory address to another without CPU intervention. Using the DMA controller can increase the throughput of peripheral modules. The DMA controller reduces system power consumption by allowing the CPU to remain in sleep mode, without having to awaken to move data to or from a peripheral. [Table 6-9](#) lists the available triggers for DMA operation.

Table 6-9. DMA Trigger Assignments⁽¹⁾

TRIGGER	CHANNEL		
	0	1	2
0	DMAREQ	DMAREQ	DMAREQ
1	TA0CCR0 CCIFG	TA0CCR0 CCIFG	TA0CCR0 CCIFG
2	TA0CCR2 CCIFG	TA0CCR2 CCIFG	TA0CCR2 CCIFG
3	TA1CCR0 CCIFG	TA1CCR0 CCIFG	TA1CCR0 CCIFG
4	TA1CCR2 CCIFG	TA1CCR2 CCIFG	TA1CCR2 CCIFG
5	Reserved	Reserved	Reserved
6	Reserved	Reserved	Reserved
7	Reserved	Reserved	Reserved
8	Reserved	Reserved	Reserved
9	Reserved	Reserved	Reserved
10	Reserved	Reserved	Reserved
11	Reserved	Reserved	Reserved
12	Reserved	Reserved	Reserved
13	Reserved	Reserved	Reserved
14	Reserved	Reserved	Reserved
15	Reserved	Reserved	Reserved
16	UCA0RXIFG	UCA0RXIFG	UCA0RXIFG
17	UCA0TXIFG	UCA0TXIFG	UCA0TXIFG
18	UCB0RXIFG	UCB0RXIFG	UCB0RXIFG
19	UCB0TXIFG	UCB0TXIFG	UCB0TXIFG
20	Reserved	Reserved	Reserved
21	Reserved	Reserved	Reserved
22	Reserved	Reserved	Reserved
23	Reserved	Reserved	Reserved
24	ADC12IFGx ⁽²⁾	ADC12IFGx ⁽²⁾	ADC12IFGx ⁽²⁾
25	Reserved	Reserved	Reserved
26	Reserved	Reserved	Reserved
27	Reserved	Reserved	Reserved
28	Reserved	Reserved	Reserved
29	MPY ready	MPY ready	MPY ready
30	DMA2IFG	DMA0IFG	DMA1IFG
31	DMAE0	DMAE0	DMAE0

(1) Reserved DMA triggers may be used by other devices in the family. Reserved DMA triggers will not cause any DMA trigger event when selected.

(2) Only on CC430F613x and CC430F513x. Reserved on CC430F612x.

6.10.7 Watchdog Timer (WDT_A)

The primary function of the watchdog timer is to perform a controlled system restart after a software problem occurs. If the selected time interval expires, a system reset is generated. If the watchdog function is not needed in an application, the timer can be configured as an interval timer and can generate interrupts at selected time intervals.

6.10.8 CRC16

The CRC16 module produces a signature based on a sequence of entered data values and can be used for data checking purposes. The CRC16 module signature is based on the CRC-CCITT standard.

6.10.9 Hardware Multiplier

The multiplication operation is supported by a dedicated peripheral module. The module performs operations with 32-, 24-, 16-, and 8-bit operands. The module supports signed and unsigned multiplication as well as signed and unsigned multiply-and-accumulate operations.

6.10.10 AES128 Accelerator

The AES accelerator module performs encryption and decryption of 128-bit data with 128-bit keys according to the Advanced Encryption Standard (AES) (FIPS PUB 197) in hardware.

6.10.11 Universal Serial Communication Interface (USCI)

The USCI module is used for serial data communication. The USCI module supports synchronous communication protocols such as SPI (3-pin or 4-pin) and I²C, and asynchronous communication protocols such as UART, enhanced UART with automatic baud-rate detection, and IrDA.

The USCI_An module provides support for SPI (3-pin or 4-pin), UART, enhanced UART, and IrDA.

The USCI_Bn module provides support for SPI (3-pin or 4-pin) and I²C.

One USCI_A0 and one USCI_B0 modules are implemented.

6.10.12 TA0

TA0 is a 16-bit timer/counter (Timer_A type) with five capture/compare registers. TA0 can support multiple capture/comparers, PWM outputs, and interval timing. TA0 also has extensive interrupt capabilities (see [Table 6-10](#)). Interrupts may be generated from the counter on overflow conditions and from each of the capture/compare registers.

Table 6-10. TA0 Signal Connections

DEVICE INPUT SIGNAL	MODULE INPUT NAME	MODULE BLOCK	MODULE OUTPUT SIGNAL	DEVICE OUTPUT SIGNAL
PM_TA0CLK	TACLK	Timer	NA	
ACLK (internal)	ACLK			
SMCLK (internal)	SMCLK			
RFCLK/192 ⁽¹⁾	INCLK			
PM_TA0CCR0A	CCI0A	CCR0	TA0	PM_TA0CCR0A
DV _{SS}	CCI0B			
DV _{SS}	GND			
DV _{CC}	V _{CC}			
PM_TA0CCR1A	CCI1A	CCR1	TA1	PM_TA0CCR1A
CBOUT (internal)	CCI1B			ADC12 (internal) ⁽²⁾ ADC12SHSx = {1}
DV _{SS}	GND			
DV _{CC}	V _{CC}			
PM_TA0CCR2A	CCI2A	CCR2	TA2	PM_TA0CCR2A
ACLK (internal)	CCI2B			
DV _{SS}	GND			
DV _{CC}	V _{CC}			
PM_TA0CCR3A	CCI3A	CCR3	TA3	PM_TA0CCR3A
GDO1 from Radio (internal)	CCI3B			
DV _{SS}	GND			
DV _{CC}	V _{CC}			
PM_TA0CCR4A	CCI4A	CCR4	TA4	PM_TA0CCR4A
GDO2 from Radio (internal)	CCI4B			
DV _{SS}	GND			
DV _{CC}	V _{CC}			

(1) If a different RFCLK divider setting is selected for a radio GDO output, this divider setting is also used for the Timer_A INCLK.

(2) Only on CC430F613x and CC430F513x

6.10.13 TA1

TA1 is a 16-bit timer/counter (Timer_A type) with three capture/compare registers. TA1 can support multiple capture/compares, PWM outputs, and interval timing (see [Table 6-11](#)). TA1 also has extensive interrupt capabilities. Interrupts may be generated from the counter on overflow conditions and from each of the capture/compare registers.

Table 6-11. TA1 Signal Connections

DEVICE INPUT SIGNAL	MODULE INPUT NAME	MODULE BLOCK	MODULE OUTPUT SIGNAL	DEVICE OUTPUT SIGNAL
				PZ
PM_TA1CLK	TACLK	Timer	NA	
ACLK (internal)	ACLK			
SMCLK (internal)	SMCLK			
RFCLK/192 ⁽¹⁾	INCLK			
PM_TA1CCR0A	CCI0A	CCR0	TA0	PM_TA1CCR0A
RF Async. Output (internal)	CCI0B			RF Async. Input (internal)
DV _{SS}	GND			
DV _{CC}	V _{CC}			
PM_TA1CCR1A	CCI1A	CCR1	TA1	PM_TA1CCR1A
CBOU _T (internal)	CCI1B			
DV _{SS}	GND			
DV _{CC}	V _{CC}			
PM_TA1CCR2A	CCI2A	CCR2	TA2	PM_TA1CCR2A
ACLK (internal)	CCI2B			
DV _{SS}	GND			
DV _{CC}	V _{CC}			

(1) If a different RFCLK divider setting is selected for a radio GDO output, this divider setting is also used for the Timer_A INCLK.

6.10.14 Real-Time Clock (RTC_A)

The RTC_A module can be used as a general-purpose 32-bit counter (counter mode) or as an integrated real-time clock (RTC) (calendar mode). In counter mode, the RTC_A also includes two independent 8-bit timers that can be cascaded to form a 16-bit timer/counter. Both timers can be read and written by software. Calendar mode integrates an internal calendar which compensates for months with less than 31 days and includes leap year correction. The RTC_A also supports flexible alarm functions and offset-calibration hardware.

6.10.15 Voltage Reference (REF)

REF generates all of the critical reference voltages that can be used by the various analog peripherals in the device. These peripherals include the ADC12_A, LCD_B, and COMP_B modules.

6.10.16 LCD_B (Only CC430F613x and CC430F612x)

The LCD_B driver generates the segment and common signals required to drive a liquid crystal display (LCD). The LCD_B controller has dedicated data memories to hold segment drive information. Common and segment signals are generated as defined by the mode. Static, 2-, 3-, and 4-mux LCDs are supported. The module can provide a LCD voltage independent of the supply voltage with its integrated charge pump. It is possible to control the level of the LCD voltage and thus contrast by software. The module also provides an automatic blinking capability for individual segments.

6.10.17 *Comparator_B*

The primary function of the Comparator_B module is to support precision slope analog-to-digital conversions, battery voltage supervision, and monitoring of external analog signals.

6.10.18 *ADC12_A (Only CC430F613x and CC430F513x)*

The ADC12_A module supports fast 12-bit analog-to-digital conversions. The module implements a 12-bit SAR core, sample select control, reference generator, and a 16-word conversion-and-control buffer. The conversion-and-control buffer allows up to 16 independent ADC samples to be converted and stored without any CPU intervention.

6.10.19 *Embedded Emulation Module (EEM) (S Version)*

The EEM supports real-time in-system debugging. The S version of the EEM has the following features:

- Three hardware triggers or breakpoints on memory access
- One hardware trigger or breakpoint on CPU register write access
- Up to four hardware triggers can be combined to form complex triggers or breakpoints
- One cycle counter
- Clock control on module level

6.10.20 Peripheral File Map

Table 6-12 lists the base address for the registers of each peripheral.

Table 6-12. Peripherals

MODULE NAME	BASE ADDRESS	OFFSET ADDRESS RANGE
Special Functions (see Table 6-13)	0100h	000h–01Fh
PMM (see Table 6-14)	0120h	000h–00Fh
Flash Control (see Table 6-15)	0140h	000h–00Fh
CRC16 (see Table 6-16)	0150h	000h–007h
RAM Control (see Table 6-17)	0158h	000h–001h
Watchdog (see Table 6-18)	015Ch	000h–001h
UCS (see Table 6-19)	0160h	000h–01Fh
SYS (see Table 6-20)	0180h	000h–01Fh
Shared Reference (see Table 6-21)	01B0h	000h–001h
Port Mapping Control (see Table 6-22)	01C0h	000h–007h
Port Mapping Port P1 (see Table 6-23)	01C8h	000h–007h
Port Mapping Port P2 (see Table 6-24)	01D0h	000h–007h
Port Mapping Port P3 (see Table 6-25)	01D8h	000h–007h
Port P1, P2 (see Table 6-26)	0200h	000h–01Fh
Port P3, P4 (see Table 6-27) (P4 not available on CC430F513x)	0220h	000h–01Fh
Port P5 (see Table 6-28)	0240h	000h–01Fh
Port PJ (see Table 6-29)	0320h	000h–01Fh
TA0 (see Table 6-30)	0340h	000h–03Fh
TA1 (see Table 6-31)	0380h	000h–03Fh
RTC_A (see Table 6-32)	04A0h	000h–01Fh
32-Bit Hardware Multiplier (see Table 6-33)	04C0h	000h–02Fh
DMA Module Control (see Table 6-34)	0500h	000h–00Fh
DMA Channel 0 (see Table 6-35)	0510h	000h–00Fh
DMA Channel 1 (see Table 6-36)	0520h	000h–00Fh
DMA Channel 2 (see Table 6-37)	0530h	000h–00Fh
USCI_A0 (see Table 6-38)	05C0h	000h–01Fh
USCI_B0 (see Table 6-39)	05E0h	000h–01Fh
ADC12 (see Table 6-40) (only CC430F613x and CC430F513x)	0700h	000h–03Fh
Comparator_B (see Table 6-41)	08C0h	000h–00Fh
AES Accelerator (see Table 6-42)	09C0h	000h–00Fh
LCD_B (see Table 6-43) (only CC430F613x and CC430F612x)	0A00h	000h–05Fh
Radio Interface (see Table 6-44)	0F00h	000h–03Fh

Table 6-13. Special Function Registers (Base Address: 0100h)

REGISTER DESCRIPTION	ACRONYM	OFFSET
SFR interrupt enable	SFRIE1	00h
SFR interrupt flag	SFRIFG1	02h
SFR reset pin control	SFRRPCR	04h

Table 6-14. PMM Registers (Base Address: 0120h)

REGISTER DESCRIPTION	ACRONYM	OFFSET
PMM control 0	PMMCTL0	00h
PMM control 1	PMMCTL1	02h
SVS high side control	SVSMHCTL	04h
SVS low side control	SVSMLCTL	06h
PMM interrupt flags	PMMIFG	0Ch
PMM interrupt enable	PMMIE	0Eh
PMM power mode 5 control	PM5CTL0	10h

Table 6-15. Flash Control Registers (Base Address: 0140h)

REGISTER DESCRIPTION	ACRONYM	OFFSET
Flash control 1	FCTL1	00h
Flash control 3	FCTL3	04h
Flash control 4	FCTL4	06h

Table 6-16. CRC16 Registers (Base Address: 0150h)

REGISTER DESCRIPTION	ACRONYM	OFFSET
CRC data input	CRC16DI	00h
CRC initialization and result	CRCINIRES	04h

Table 6-17. RAM Control Registers (Base Address: 0158h)

REGISTER DESCRIPTION	ACRONYM	OFFSET
RAM control 0	RCCTL0	00h

Table 6-18. Watchdog Registers (Base Address: 015Ch)

REGISTER DESCRIPTION	ACRONYM	OFFSET
Watchdog timer control	WDTCTL	00h

Table 6-19. UCS Registers (Base Address: 0160h)

REGISTER DESCRIPTION	ACRONYM	OFFSET
UCS control 0	UCSCTL0	00h
UCS control 1	UCSCTL1	02h
UCS control 2	UCSCTL2	04h
UCS control 3	UCSCTL3	06h
UCS control 4	UCSCTL4	08h
UCS control 5	UCSCTL5	0Ah
UCS control 6	UCSCTL6	0Ch
UCS control 7	UCSCTL7	0Eh
UCS control 8	UCSCTL8	10h

Table 6-20. SYS Registers (Base Address: 0180h)

REGISTER DESCRIPTION	ACRONYM	OFFSET
System control	SYSCTL	00h
Bootloader configuration area	SYSBSLC	02h
JTAG mailbox control	SYSJMBC	06h
JTAG mailbox input 0	SYSJMBI0	08h
JTAG mailbox input 1	SYSJMBI1	0Ah
JTAG mailbox output 0	SYSJMBO0	0Ch
JTAG mailbox output 1	SYSJMBO1	0Eh
Bus error vector generator	SYSBERRIV	18h
User NMI vector generator	SYSUNIV	1Ah
System NMI vector generator	SYSSNIV	1Ch
Reset vector generator	SYSRSTIV	1Eh

Table 6-21. Shared Reference Registers (Base Address: 01B0h)

REGISTER DESCRIPTION	ACRONYM	OFFSET
Shared reference control	REFCTL	00h

Table 6-22. Port Mapping Control Registers (Base Address: 01C0h)

REGISTER DESCRIPTION	ACRONYM	OFFSET
Port mapping key	PMAPKEYID	00h
Port mapping control	PMAPCTL	02h

Table 6-23. Port Mapping Port P1 Registers (Base Address: 01C8h)

REGISTER DESCRIPTION	ACRONYM	OFFSET
Port P1.0 mapping	P1MAP0	00h
Port P1.1 mapping	P1MAP1	01h
Port P1.2 mapping	P1MAP2	02h
Port P1.3 mapping	P1MAP3	03h
Port P1.4 mapping	P1MAP4	04h
Port P1.5 mapping	P1MAP5	05h
Port P1.6 mapping	P1MAP6	06h
Port P1.7 mapping	P1MAP7	07h

Table 6-24. Port Mapping Port P2 Registers (Base Address: 01D0h)

REGISTER DESCRIPTION	ACRONYM	OFFSET
Port P2.0 mapping	P2MAP0	00h
Port P2.1 mapping	P2MAP1	01h
Port P2.2 mapping	P2MAP2	02h
Port P2.3 mapping	P2MAP3	03h
Port P2.4 mapping	P2MAP4	04h
Port P2.5 mapping	P2MAP5	05h
Port P2.6 mapping	P2MAP6	06h
Port P2.7 mapping	P2MAP7	07h

Table 6-25. Port Mapping Port P3 Registers (Base Address: 01D8h)

REGISTER DESCRIPTION	ACRONYM	OFFSET
Port P3.0 mapping	P3MAP0	00h
Port P3.1 mapping	P3MAP1	01h
Port P3.2 mapping	P3MAP2	02h
Port P3.3 mapping	P3MAP3	03h
Port P3.4 mapping	P3MAP4	04h
Port P3.5 mapping	P3MAP5	05h
Port P3.6 mapping	P3MAP6	06h
Port P3.7 mapping	P3MAP7	07h

Table 6-26. Port P1, P2 Registers (Base Address: 0200h)

REGISTER DESCRIPTION	ACRONYM	OFFSET
Port P1 input	P1IN	00h
Port P1 output	P1OUT	02h
Port P1 direction	P1DIR	04h
Port P1 pullup/pulldown enable	P1REN	06h
Port P1 drive strength	P1DS	08h
Port P1 selection	P1SEL	0Ah
Port P1 interrupt vector word	P1IV	0Eh
Port P1 interrupt edge select	P1IES	18h
Port P1 interrupt enable	P1IE	1Ah
Port P1 interrupt flag	P1IFG	1Ch
Port P2 input	P2IN	01h
Port P2 output	P2OUT	03h
Port P2 direction	P2DIR	05h
Port P2 pullup/pulldown enable	P2REN	07h
Port P2 drive strength	P2DS	09h
Port P2 selection	P2SEL	0Bh
Port P2 interrupt vector word	P2IV	1Eh
Port P2 interrupt edge select	P2IES	19h
Port P2 interrupt enable	P2IE	1Bh
Port P2 interrupt flag	P2IFG	1Dh

Table 6-27. Port P3, P4 Registers (Base Address: 0220h)

REGISTER DESCRIPTION	ACRONYM	OFFSET
Port P3 input	P3IN	00h
Port P3 output	P3OUT	02h
Port P3 direction	P3DIR	04h
Port P3 pullup/pulldown enable	P3REN	06h
Port P3 drive strength	P3DS	08h
Port P3 selection	P3SEL	0Ah
Port P4 input	P4IN	01h
Port P4 output	P4OUT	03h
Port P4 direction	P4DIR	05h
Port P4 pullup/pulldown enable	P4REN	07h
Port P4 drive strength	P4DS	09h
Port P4 selection	P4SEL	0Bh

Table 6-28. Port P5 Registers (Base Address: 0240h)

REGISTER DESCRIPTION	ACRONYM	OFFSET
Port P5 input	P5IN	00h
Port P5 output	P5OUT	02h
Port P5 direction	P5DIR	04h
Port P5 pullup/pulldown enable	P5REN	06h
Port P5 drive strength	P5DS	08h
Port P5 selection	P5SEL	0Ah

Table 6-29. Port J Registers (Base Address: 0320h)

REGISTER DESCRIPTION	ACRONYM	OFFSET
Port PJ input	PJIN	00h
Port PJ output	PJOUT	02h
Port PJ direction	PJDIR	04h
Port PJ pullup/pulldown enable	PJREN	06h
Port PJ drive strength	PJDS	08h

Table 6-30. TA0 Registers (Base Address: 0340h)

REGISTER DESCRIPTION	ACRONYM	OFFSET
TA0 control	TA0CTL	00h
Capture/compare control 0	TA0CCTL0	02h
Capture/compare control 1	TA0CCTL1	04h
Capture/compare control 2	TA0CCTL2	06h
Capture/compare control 3	TA0CCTL3	08h
Capture/compare control 4	TA0CCTL4	0Ah
TA0 counter	TA0R	10h
Capture/compare 0	TA0CCR0	12h
Capture/compare 1	TA0CCR1	14h
Capture/compare 2	TA0CCR2	16h
Capture/compare 3	TA0CCR3	18h
Capture/compare 4	TA0CCR4	1Ah
TA0 expansion 0	TA0EX0	20h
TA0 interrupt vector	TA0IV	2Eh

Table 6-31. TA1 Registers (Base Address: 0380h)

REGISTER DESCRIPTION	ACRONYM	OFFSET
TA1 control	TA1CTL	00h
Capture/compare control 0	TA1CCTL0	02h
Capture/compare control 1	TA1CCTL1	04h
Capture/compare control 2	TA1CCTL2	06h
TA1 counter	TA1R	10h
Capture/compare 0	TA1CCR0	12h
Capture/compare 1	TA1CCR1	14h
Capture/compare 2	TA1CCR2	16h
TA1 expansion 0	TA1EX0	20h
TA1 interrupt vector	TA1IV	2Eh

Table 6-32. Real-Time Clock Registers (Base Address: 04A0h)

REGISTER DESCRIPTION	ACRONYM	OFFSET
RTC control 0	RTCCTL0	00h
RTC control 1	RTCCTL1	01h
RTC control 2	RTCCTL2	02h
RTC control 3	RTCCTL3	03h
RTC prescaler 0 control	RTCP50CTL	08h
RTC prescaler 1 control	RTCP51CTL	0Ah
RTC prescaler 0	RTCP50	0Ch
RTC prescaler 1	RTCP51	0Dh
RTC interrupt vector word	RTCIV	0Eh
RTC seconds/counter 1	RTCSEC/RTCNT1	10h
RTC minutes/counter 2	RTCMIN/RTCNT2	11h
RTC hours/counter 3	RTCHOUR/RTCNT3	12h
RTC day of week/counter 4	RTCDOW/RTCNT4	13h
RTC days	RTCDAY	14h
RTC month	RTCMON	15h
RTC year low	RTCYEARL	16h
RTC year high	RTCYEARH	17h
RTC alarm minutes	RTCAMIN	18h
RTC alarm hours	RTCAHOUR	19h
RTC alarm day of week	RTCADOW	1Ah
RTC alarm days	RTCADAY	1Bh

Table 6-33. 32-Bit Hardware Multiplier Registers (Base Address: 04C0h)

REGISTER DESCRIPTION	ACRONYM	OFFSET
16-bit operand 1 – multiply	MPY	00h
16-bit operand 1 – signed multiply	MPYS	02h
16-bit operand 1 – multiply accumulate	MAC	04h
16-bit operand 1 – signed multiply accumulate	MACS	06h
16-bit operand 2	OP2	08h
16 × 16 result low word	RESLO	0Ah
16 × 16 result high word	RESHI	0Ch
16 × 16 sum extension	SUMEXT	0Eh
32-bit operand 1 – multiply low word	MPY32L	10h
32-bit operand 1 – multiply high word	MPY32H	12h
32-bit operand 1 – signed multiply low word	MPYS32L	14h
32-bit operand 1 – signed multiply high word	MPYS32H	16h
32-bit operand 1 – multiply accumulate low word	MAC32L	18h
32-bit operand 1 – multiply accumulate high word	MAC32H	1Ah
32-bit operand 1 – signed multiply accumulate low word	MACS32L	1Ch
32-bit operand 1 – signed multiply accumulate high word	MACS32H	1Eh
32-bit operand 2 – low word	OP2L	20h
32-bit operand 2 – high word	OP2H	22h
32 × 32 result 0 – least significant word	RES0	24h
32 × 32 result 1	RES1	26h
32 × 32 result 2	RES2	28h
32 × 32 result 3 – most significant word	RES3	2Ah
MPY32 control 0	MPY32CTL0	2Ch

Table 6-34. DMA Module Control Registers (Base Address: 0500h)

REGISTER DESCRIPTION	ACRONYM	OFFSET
DMA module control 0	DMACTL0	00h
DMA module control 1	DMACTL1	02h
DMA module control 2	DMACTL2	04h
DMA module control 3	DMACTL3	06h
DMA module control 4	DMACTL4	08h
DMA interrupt vector	DMAIV	0Ah

Table 6-35. DMA Channel 0 Registers (Base Address: 0510h)

REGISTER DESCRIPTION	ACRONYM	OFFSET
DMA channel 0 control	DMA0CTL	00h
DMA channel 0 source address low	DMA0SAL	02h
DMA channel 0 source address high	DMA0SAH	04h
DMA channel 0 destination address low	DMA0DAL	06h
DMA channel 0 destination address high	DMA0DAH	08h
DMA channel 0 transfer size	DMA0SZ	0Ah

Table 6-36. DMA Channel 1 Registers (Base Address: 0520h)

REGISTER DESCRIPTION	ACRONYM	OFFSET
DMA channel 1 control	DMA1CTL	00h
DMA channel 1 source address low	DMA1SAL	02h
DMA channel 1 source address high	DMA1SAH	04h
DMA channel 1 destination address low	DMA1DAL	06h
DMA channel 1 destination address high	DMA1DAH	08h
DMA channel 1 transfer size	DMA1SZ	0Ah

Table 6-37. DMA Channel 2 Registers (Base Address: 0530h)

REGISTER DESCRIPTION	ACRONYM	OFFSET
DMA channel 2 control	DMA2CTL	00h
DMA channel 2 source address low	DMA2SAL	02h
DMA channel 2 source address high	DMA2SAH	04h
DMA channel 2 destination address low	DMA2DAL	06h
DMA channel 2 destination address high	DMA2DAH	08h
DMA channel 2 transfer size	DMA2SZ	0Ah

Table 6-38. USCI_A0 Registers (Base Address: 05C0h)

REGISTER DESCRIPTION	ACRONYM	OFFSET
USCI control 1	UCA0CTL1	00h
USCI control 0	UCA0CTL0	01h
USCI baud rate 0	UCA0BR0	06h
USCI baud rate 1	UCA0BR1	07h
USCI modulation control	UCA0MCTL	08h
USCI status	UCA0STAT	0Ah
USCI receive buffer	UCA0RXBUF	0Ch
USCI transmit buffer	UCA0TXBUF	0Eh
USCI LIN control	UCA0ABCTL	10h
USCI IrDA transmit control	UCA0IRTCTL	12h
USCI IrDA receive control	UCA0IRRCTL	13h
USCI interrupt enable	UCA0IE	1Ch
USCI interrupt flags	UCA0IFG	1Dh
USCI interrupt vector word	UCA0IV	1Eh

Table 6-39. USCI_B0 Registers (Base Address: 05E0h)

REGISTER DESCRIPTION	ACRONYM	OFFSET
USCI synchronous control 1	UCB0CTL1	00h
USCI synchronous control 0	UCB0CTL0	01h
USCI synchronous bit rate 0	UCB0BR0	06h
USCI synchronous bit rate 1	UCB0BR1	07h
USCI synchronous status	UCB0STAT	0Ah
USCI synchronous receive buffer	UCB0RXBUF	0Ch
USCI synchronous transmit buffer	UCB0TXBUF	0Eh
USCI I2C own address	UCB0I2COA	10h
USCI I2C slave address	UCB0I2CSA	12h
USCI interrupt enable	UCB0IE	1Ch
USCI interrupt flags	UCB0IFG	1Dh
USCI interrupt vector word	UCB0IV	1Eh

Table 6-40. ADC12_A Registers (Base Address: 0700h)

REGISTER DESCRIPTION	ACRONYM	OFFSET
Control 0	ADC12CTL0	00h
Control 1	ADC12CTL1	02h
Control 2	ADC12CTL2	04h
Interrupt flag	ADC12IFG	0Ah
Interrupt enable	ADC12IE	0Ch
Interrupt vector word	ADC12IV	0Eh
ADC memory-control 0	ADC12MCTL0	10h
ADC memory-control 1	ADC12MCTL1	11h
ADC memory-control 2	ADC12MCTL2	12h
ADC memory-control 3	ADC12MCTL3	13h
ADC memory-control 4	ADC12MCTL4	14h
ADC memory-control 5	ADC12MCTL5	15h
ADC memory-control 6	ADC12MCTL6	16h
ADC memory-control 7	ADC12MCTL7	17h
ADC memory-control 8	ADC12MCTL8	18h
ADC memory-control 9	ADC12MCTL9	19h
ADC memory-control 10	ADC12MCTL10	1Ah
ADC memory-control 11	ADC12MCTL11	1Bh
ADC memory-control 12	ADC12MCTL12	1Ch
ADC memory-control 13	ADC12MCTL13	1Dh
ADC memory-control 14	ADC12MCTL14	1Eh
ADC memory-control 15	ADC12MCTL15	1Fh
Conversion memory 0	ADC12MEM0	20h
Conversion memory 1	ADC12MEM1	22h
Conversion memory 2	ADC12MEM2	24h
Conversion memory 3	ADC12MEM3	26h
Conversion memory 4	ADC12MEM4	28h
Conversion memory 5	ADC12MEM5	2Ah
Conversion memory 6	ADC12MEM6	2Ch
Conversion memory 7	ADC12MEM7	2Eh
Conversion memory 8	ADC12MEM8	30h
Conversion memory 9	ADC12MEM9	32h
Conversion memory 10	ADC12MEM10	34h
Conversion memory 11	ADC12MEM11	36h
Conversion memory 12	ADC12MEM12	38h
Conversion memory 13	ADC12MEM13	3Ah
Conversion memory 14	ADC12MEM14	3Ch
Conversion memory 15	ADC12MEM15	3Eh

Table 6-41. Comparator_B Registers (Base Address: 08C0h)

REGISTER DESCRIPTION	ACRONYM	OFFSET
Comp_B control 0	CBCTL0	00h
Comp_B control 1	CBCTL1	02h
Comp_B control 2	CBCTL2	04h
Comp_B control 3	CBCTL3	06h
Comp_B interrupt	CBINT	0Ch
Comp_B interrupt vector word	CBIV	0Eh

Table 6-42. AES Accelerator Registers (Base Address: 09C0h)

REGISTER DESCRIPTION	ACRONYM	OFFSET
AES accelerator control 0	AESACTL0	00h
Reserved		02h
AES accelerator status	AESASTAT	04h
AES accelerator key	AESAKEY	06h
AES accelerator data in	AESADIN	008h
AES accelerator data out	AESADOUT	00Ah

Table 6-43. LCD_B Registers (Base Address: 0A00h)

REGISTER DESCRIPTION	ACRONYM	OFFSET
LCD_B control 0	LCDBCTL0	000h
LCD_B control 1	LCDBCTL1	002h
LCD_B blinking control	LCDBBLKCTL	004h
LCD_B memory control	LCDBMEMCTL	006h
LCD_B voltage control	LCDBVCTL	008h
LCD_B port control 0	LCDBPCTL0	00Ah
LCD_B port control 1	LCDBPCTL1	00Ch
LCD_B charge pump control	LCDBCTL0	012h
LCD_B interrupt vector word	LCDBIV	01Eh
LCD_B memory 1	LCDM1	020h
LCD_B memory 2	LCDM2	021h
...		
LCD_B memory 14	LCDM14	02Dh
LCD_B blinking memory 1	LCDBM1	040h
LCD_B blinking memory 2	LCDBM2	041h
...		
LCD_B blinking memory 14	LCDBM14	04Dh

Table 6-44. Radio Interface Registers (Base Address: 0F00h)

REGISTER DESCRIPTION	ACRONYM	OFFSET
Radio interface control 0	RF1AIFCTL0	00h
Radio interface control 1	RF1AIFCTL1	02h
Radio interface error flag	RF1AIFERR	06h
Radio interface error vector word	RF1AIFERRV	0Ch
Radio interface interrupt vector word	RF1AIFIV	0Eh
Radio instruction word	RF1AINSTRW	10h
Radio instruction word, 1-byte auto-read	RF1AINSTR1W	12h
Radio instruction word, 2-byte auto-read	RF1AINSTR2W	14h
Radio data in	RF1ADINW	16h
Radio status word	RF1ASTATW	20h
Radio status word, 1-byte auto-read	RF1ASTAT1W	22h
Radio status word, 2-byte auto-read	RF1AISTAT2W	24h
Radio data out	RF1ADOUTW	28h
Radio data out, 1-byte auto-read	RF1ADOUT1W	2Ah
Radio data out, 2-byte auto-read	RF1ADOUT2W	2Ch
Radio core signal input	RF1AIN	30h
Radio core interrupt flag	RF1AIFG	32h
Radio core interrupt edge select	RF1AIES	34h
Radio core interrupt enable	RF1AIE	36h
Radio core interrupt vector word	RF1AIV	38h

6.11 Input/Output Diagrams

6.11.1 Port P1 (P1.0 to P1.4) Input/Output With Schmitt Trigger

Figure 6-2 shows the port diagram. Table 6-45 summarizes the selection of the pin functions.

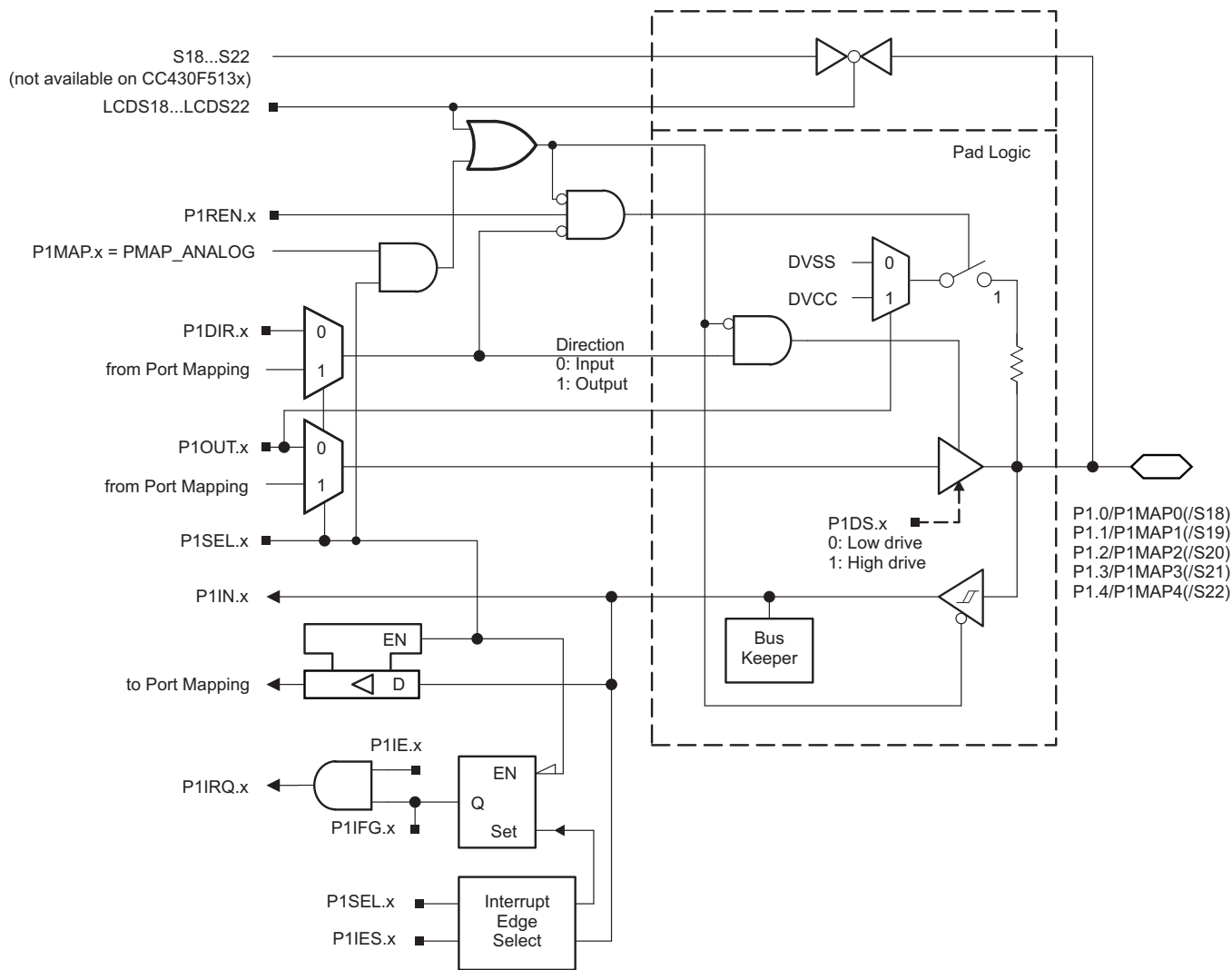

CC430F513x devices do not provide LCD functionality on port P1 pins.

Figure 6-2. Port P1 (P1.0 to P1.4) Diagram

Table 6-45. Port P1 (P1.0 to P1.4) Pin Functions

PIN NAME (P1.x)	x	FUNCTION	CONTROL BITS OR SIGNALS ⁽¹⁾			
			P1DIR.x	P1SEL.x	P1MAPx	LCDS18 to LCDS22 ⁽²⁾
P1.0/P1MAP/S18	0	P1.0 (I/O)	I: 0; O: 1	0	X	0
		Mapped secondary digital function – see Table 6-6	0; 1 ⁽³⁾	1	≤ 30 ⁽³⁾	0
		Output driver and input Schmitt trigger disabled	X	1	= 31	0
		S18 (not available on CC430F513x)	X	X	X	1
P1.1/P1MAP1/S19	1	P1.1 (I/O)	I: 0; O: 1	0	X	0
		Mapped secondary digital function – see Table 6-6	0; 1 ⁽³⁾	1	≤ 30 ⁽³⁾	0
		Output driver and input Schmitt trigger disabled	X	1	= 31	0
		S19 (not available on CC430F513x)	X	X	X	1
P1.2/P1MAP2/S20	2	P1.2 (I/O)	I: 0; O: 1	0	X	0
		Mapped secondary digital function – see Table 6-6	0; 1 ⁽³⁾	1	≤ 30 ⁽³⁾	0
		Output driver and input Schmitt trigger disabled	X	1	= 31	0
		S22 (not available on CC430F513x)	X	X	X	1
P1.3/P1MAP3/S21	3	P1.3 (I/O)	I: 0; O: 1	0	X	0
		Mapped secondary digital function – see Table 6-6	0; 1 ⁽³⁾	1	≤ 30 ⁽³⁾	0
		Output driver and input Schmitt trigger disabled	X	1	= 31	0
		S21 (not available on CC430F513x)	X	X	X	1
P1.4/P1MAP4/S22	4	P1.4 (I/O)	I: 0; O: 1	0	X	0
		Mapped secondary digital function – see Table 6-6	0; 1 ⁽³⁾	1	≤ 30 ⁽³⁾	0
		Output driver and input Schmitt trigger disabled	X	1	= 31	0
		S22 (not available on CC430F513x)	X	X	X	1

- (1) X = don't care
- (2) LCDSx not available in CC430F513x.
- (3) According to mapped function – see [Table 6-6](#).

6.11.2 Port P1 (P1.5 to P1.7) Input/Output With Schmitt Trigger

Figure 6-3 shows the port diagram. Table 6-46 summarizes the selection of the pin functions.

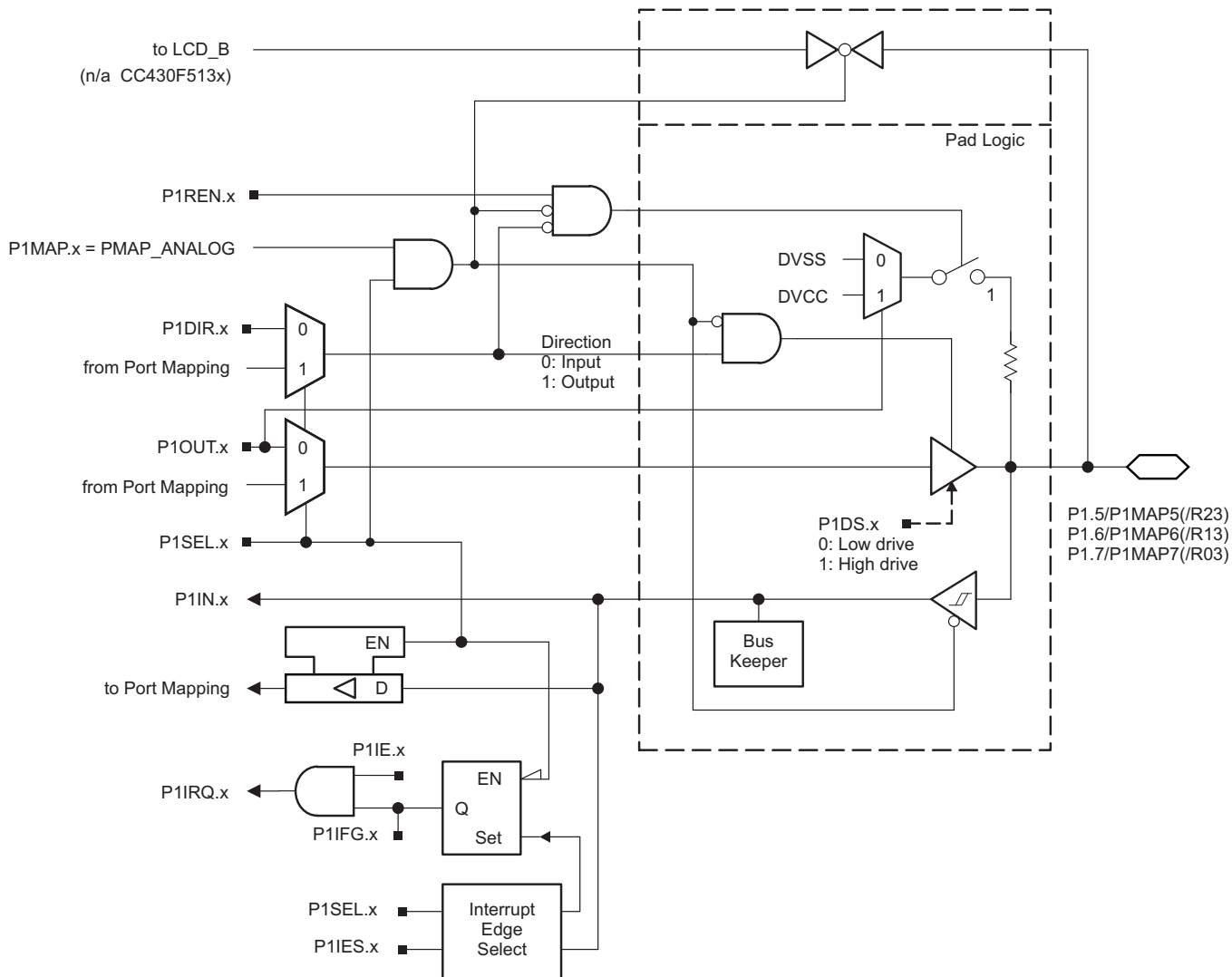

Figure 6-3. Port P1 (P1.5 to P1.7) Diagram

Table 6-46. Port P1 (P1.5 to P1.7) Pin Functions

PIN NAME (P1.x)	x	FUNCTION	CONTROL BITS OR SIGNALS ⁽¹⁾		
			P1DIR.x	P1SEL.x	P1MAPx
P1.5/P1MAP5/R23	5	P1.5 (I/O)	I: 0; O: 1	0	X
		Mapped secondary digital function – see Table 6-6	0; 1 ⁽²⁾	1	≤ 30 ⁽²⁾
		R23 ⁽³⁾ (not available on CC430F513x)	X	1	= 31
P1.6/P1MAP6/R13/ LCDREF	6	P1.6 (I/O)	I: 0; O: 1	0	X
		Mapped secondary digital function – see Table 6-6	0; 1 ⁽²⁾	1	≤ 30 ⁽²⁾
		R13/LCDREF ⁽³⁾ (not available on CC430F513x)	X	1	= 31
P1.7/P1MAP7/R03	7	P1.7 (I/O)	I: 0; O: 1	0	X
		Mapped secondary digital function – see Table 6-6	0; 1 ⁽²⁾	1	≤ 30 ⁽²⁾
		R03 ⁽³⁾ (not available on CC430F513x)	X	1	= 31

- (1) X = don't care
- (2) According to mapped function – see [Table 6-6](#).
- (3) Setting P1SEL.x bit together with P1MAPx = PM_ANALOG disables the output driver and the input Schmitt trigger.

6.11.3 Port P2 (P2.0 to P2.7) Input/Output With Schmitt Trigger

Figure 6-4 through Figure 6-6 show the port diagrams. Table 6-47 summarizes the selection of the pin functions.

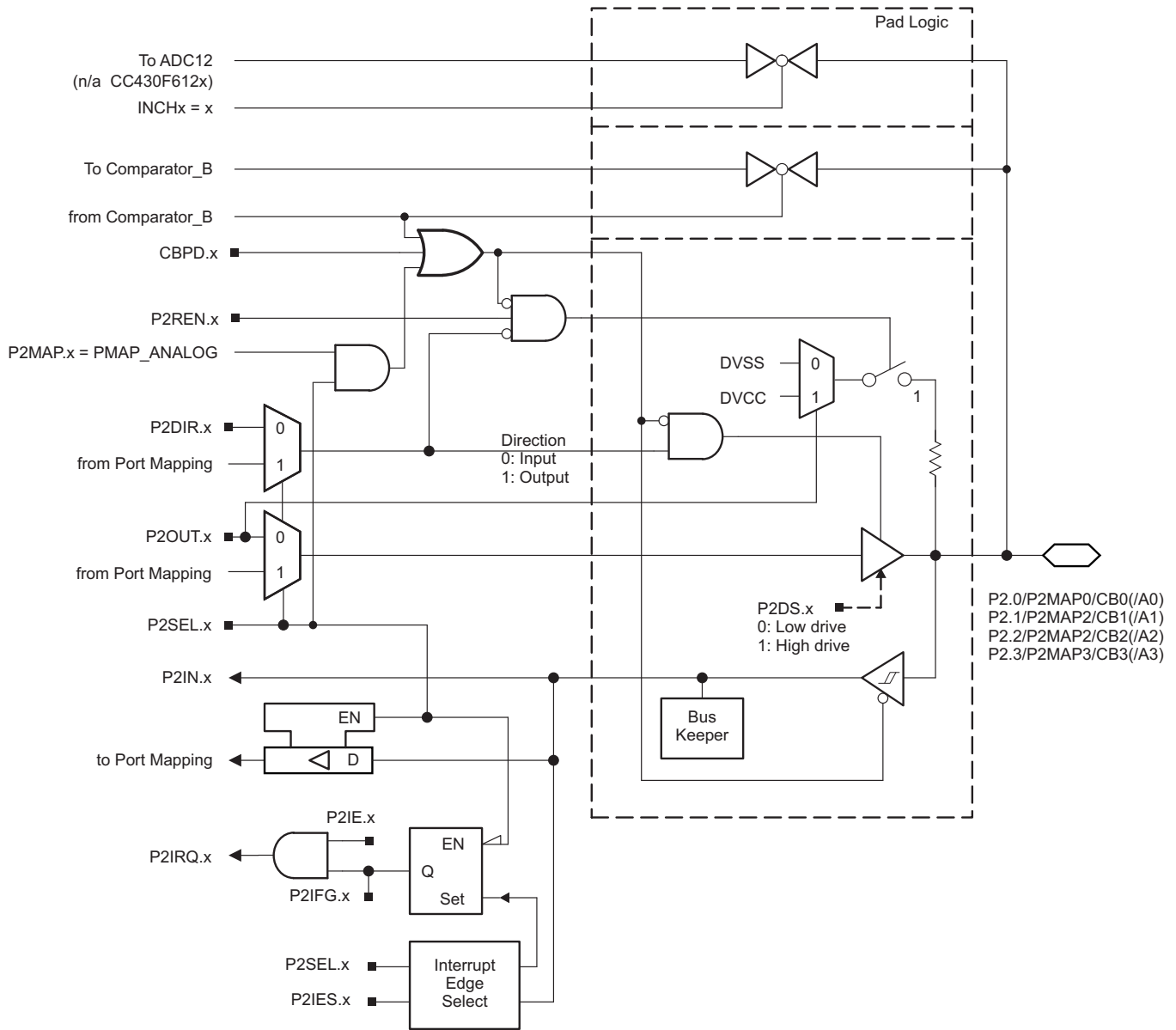

Figure 6-4. Port P2 (P2.0 to P2.3) Diagram

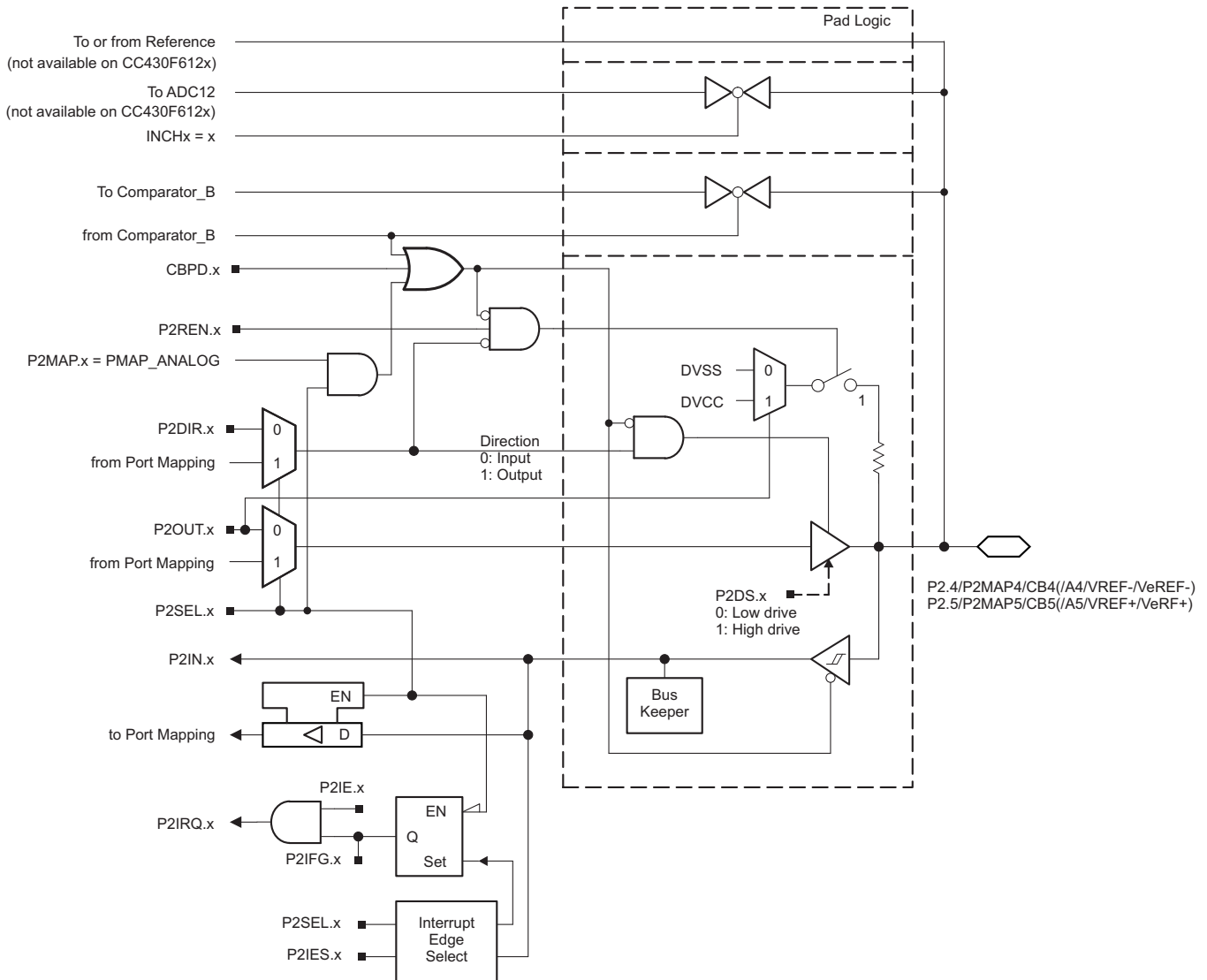
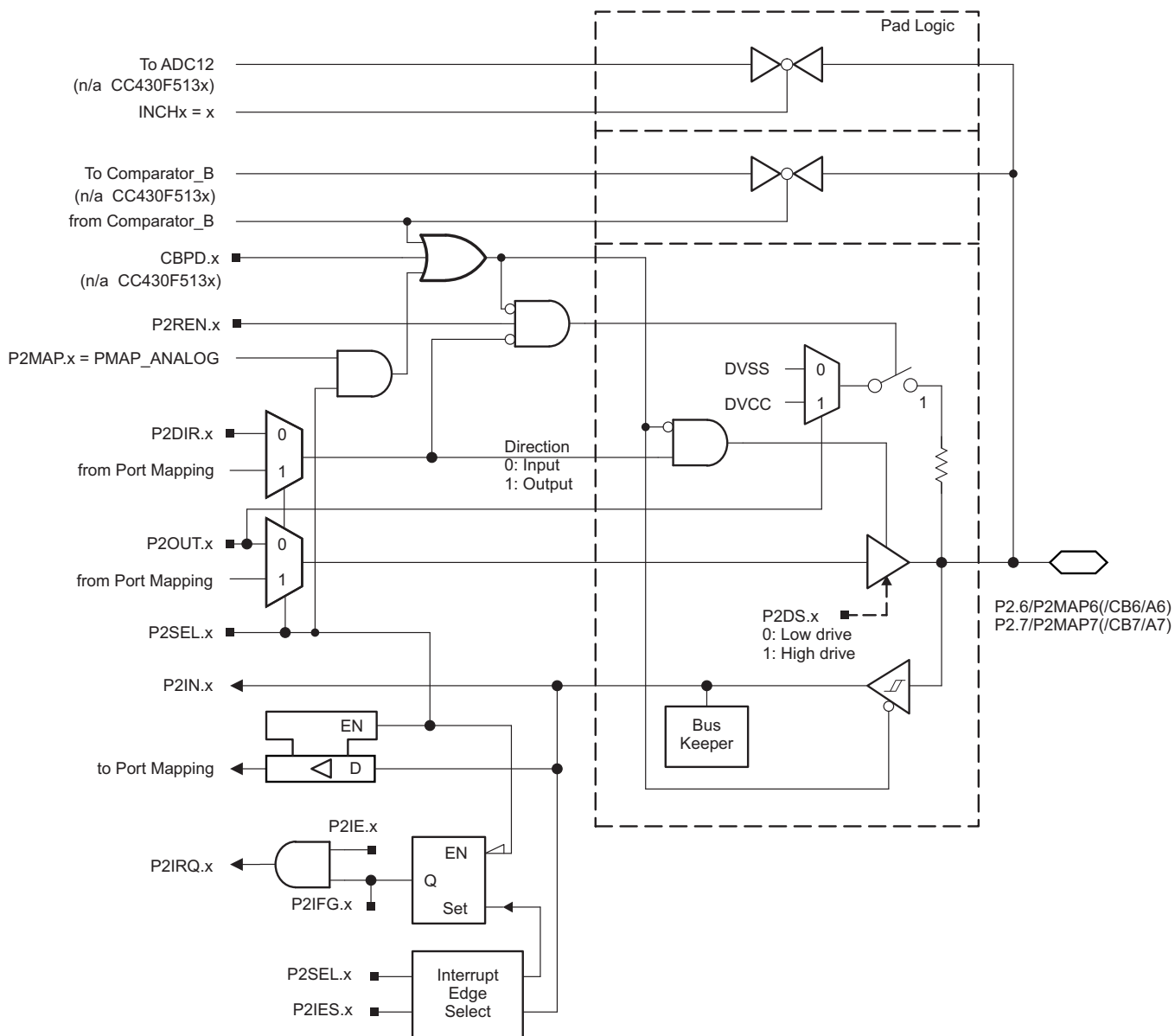

Figure 6-5. Port P2 (P2.4 and P2.5) Diagram



CC430F513x devices do not provide analog functionality on port P2.6 and P2.7 pins.

Figure 6-6. Port P2 (P2.6 and P2.7) Diagram

Table 6-47. Port P2 (P2.0 to P2.7) Pin Functions

PIN NAME (P2.x)	x	FUNCTION	CONTROL BITS OR SIGNALS ⁽¹⁾			
			P2DIR.x	P2SEL.x	P2MAPx	CBPD.x
P2.0/P2MAP0/CB0 (/A0)	0	P2.0 (I/O)	I: 0; O: 1	0	X	0
		Mapped secondary digital function – see Table 6-6	0; 1 ⁽²⁾	1	≤ 30 ⁽²⁾	0
		A0 (not available on CC430F612x) ⁽³⁾	X	1	= 31	X
		CB0 ⁽⁴⁾	X	X	X	1
P2.1/P2MAP1/CB1 (/A1)	1	P2.1 (I/O)	I: 0; O: 1	0	X	0
		Mapped secondary digital function – see Table 6-6	0; 1 ⁽²⁾	1	≤ 30 ⁽²⁾	0
		A1 (not available on CC430F612x) ⁽³⁾	X	1	= 31	X
		CB1 ⁽⁴⁾	X	X	X	1
P2.2/P2MAP2/CB2 (/A2)	2	P2.2 (I/O)	I: 0; O: 1	0	X	0
		Mapped secondary digital function – see Table 6-6	0; 1 ⁽²⁾	1	≤ 30 ⁽²⁾	0
		A2 (not available on CC430F612x) ⁽³⁾	X	1	= 31	X
		CB2 ⁽⁴⁾	X	X	X	1
P2.3/P2MAP3/CB3 (/A3)	3	P2.3 (I/O)	I: 0; O: 1	0	X	0
		Mapped secondary digital function – see Table 6-6	0; 1 ⁽²⁾	1	≤ 30 ⁽²⁾	0
		A3 (not available on CC430F612x) ⁽³⁾	X	1	= 31	X
		CB3 ⁽⁴⁾	X	X	X	1
P2.4/P2MAP4/CB4 (/A4/VREF-/VeREF-)	4	P2.4 (I/O)	I: 0; O: 1	0	X	0
		Mapped secondary digital function – see Table 6-6	0; 1 ⁽²⁾	1	≤ 30 ⁽²⁾	0
		A4/VREF-/VeREF- (not available on CC430F612x) ⁽³⁾	X	1	= 31	X
		CB4 ⁽⁴⁾	X	X	X	1
P2.5/P2MAP5/CB5 (/A5/VREF+/VeREF+)	5	P2.5 (I/O)	I: 0; O: 1	0	X	0
		Mapped secondary digital function – see Table 6-6	0; 1 ⁽²⁾	1	≤ 30 ⁽²⁾	0
		A5/VREF+/VeREF+ (not available on CC430F612x) ⁽³⁾	X	1	= 31	X
		CB5 ⁽⁴⁾	X	X	X	1
P2.6/P2MAP6/(CB6) (/A6)	6	P2.6 (I/O)	I: 0; O: 1	0	X	0
		Mapped secondary digital function – see Table 6-6	0; 1 ⁽²⁾	1	≤ 30 ⁽²⁾	0
		A6 (not available on CC430F612x and CC430F513x) ⁽³⁾	X	1	= 31	X
		CB6 (not available on CC430F513x) ⁽⁴⁾	X	X	X	1
P2.7/P2MAP7/(CB7) (/A7)	7	P2.7 (I/O)	I: 0; O: 1	0	X	0
		Mapped secondary digital function – see Table 6-6	0; 1 ⁽²⁾	1	≤ 30 ⁽²⁾	0
		A7 (not available on CC430F612x and CC430F513x) ⁽³⁾	X	1	= 31	X
		CB7 (not available on CC430F513x) ⁽⁴⁾	X	X	X	1

- (1) X = don't care
- (2) According to mapped function – see [Table 6-6](#).
- (3) Setting P2SEL.x bit together with P2MAPx = PM_ANALOG disables the output driver and the input Schmitt trigger.
- (4) Setting the CBPD.x bit disables the output driver and the input Schmitt trigger to prevent parasitic cross currents when applying analog signals. Selecting the CBx input pin to the comparator multiplexer with the CBx bits automatically disables output driver and input buffer for that pin, regardless of the state of the associated CBPD.x bit.

6.11.4 Port P3 (P3.0 to P3.7) Input/Output With Schmitt Trigger

Figure 6-7 shows the port diagram. Table 6-48 summarizes the selection of the pin functions.

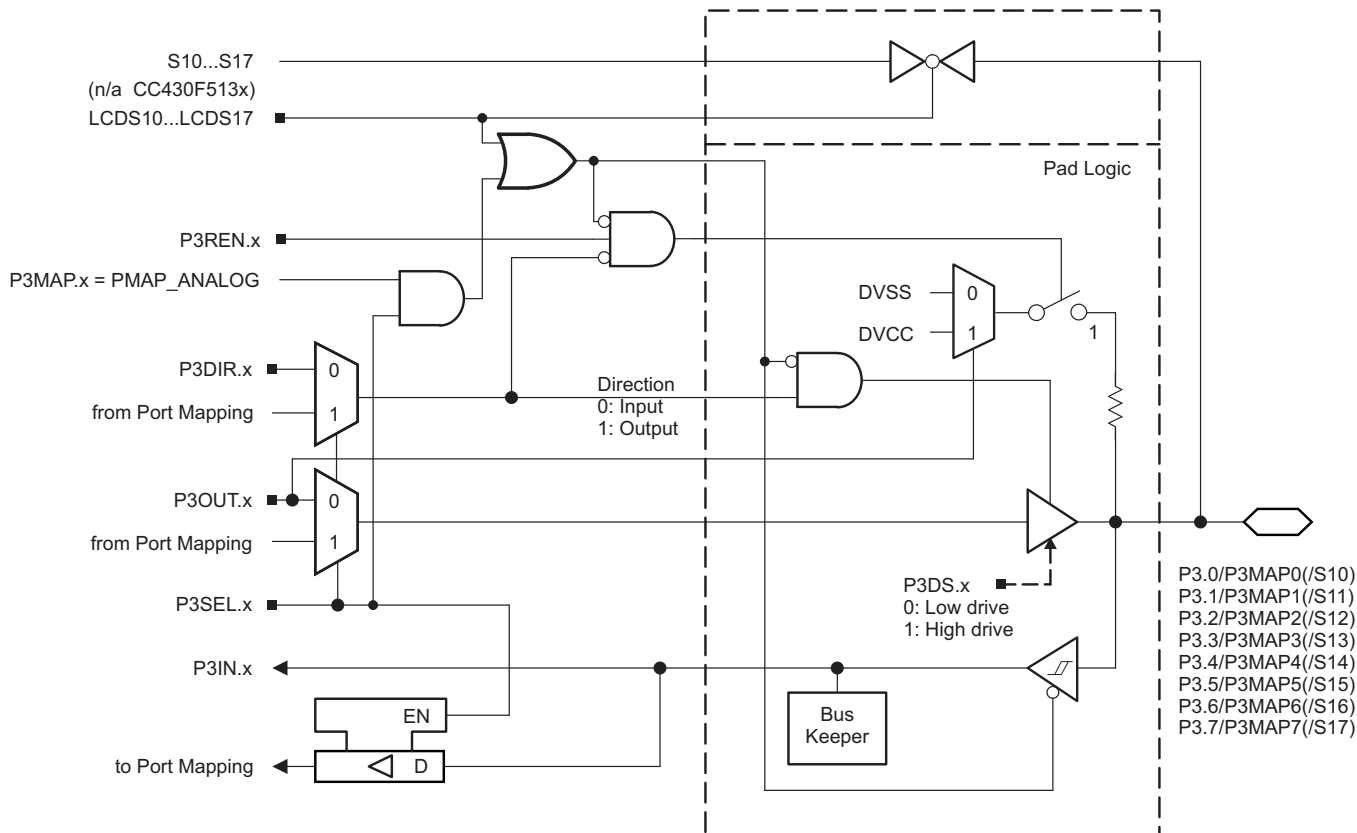

CC430F513x devices do not provide LCD functionality on port P3 pins.

Figure 6-7. Port P3 (P3.0 to P3.7) Diagram

Table 6-48. Port P3 (P3.0 to P3.7) Pin Functions

PIN NAME (P3.x)	x	FUNCTION	CONTROL BITS OR SIGNALS ⁽¹⁾			
			P3DIR.x	P3SEL.x	P3MAPx	LCDS10 to LCDS17 ⁽²⁾
P3.0/P3MAP0/S10	0	P3.0 (I/O)	I: 0; O: 1	0	X	0
		Mapped secondary digital function – see Table 6-6	0; 1 ⁽³⁾	1	≤ 30 ⁽³⁾	0
		Output driver and input Schmitt trigger disabled	X	1	= 31	0
		S10 (not available on CC430F513x)	X	X	X	1
P3.1/P3MAP1/S11	1	P3.1 (I/O)	I: 0; O: 1	0	X	0
		Mapped secondary digital function – see Table 6-6	0; 1 ⁽³⁾	1	≤ 30 ⁽³⁾	0
		Output driver and input Schmitt trigger disabled	X	1	= 31	0
		S11 (not available on CC430F513x)	X	X	X	1
P3.2/P3MAP7/S12	2	P3.2 (I/O)	I: 0; O: 1	0	X	0
		Mapped secondary digital function – see Table 6-6	0; 1 ⁽³⁾	1	≤ 30 ⁽³⁾	0
		Output driver and input Schmitt trigger disabled	X	1	= 31	0
		S12 (not available on CC430F513x)	X	X	X	1
P3.3/P3MAP3/S13	3	P3.3 (I/O)	I: 0; O: 1	0	X	0
		Mapped secondary digital function – see Table 6-6	0; 1 ⁽³⁾	1	≤ 30 ⁽³⁾	0
		Output driver and input Schmitt trigger disabled	X	1	= 31	0
		S13 (not available on CC430F513x)	X	X	X	1
P3.4/P3MAP4/S14	4	P3.4 (I/O)	I: 0; O: 1	0	X	0
		Mapped secondary digital function – see Table 6-6	0; 1 ⁽³⁾	1	≤ 30 ⁽³⁾	0
		Output driver and input Schmitt trigger disabled	X	1	= 31	0
		S14 (not available on CC430F513x)	X	X	X	1
P3.5/P3MAP5/S15	5	P3.5 (I/O)	I: 0; O: 1	0	X	0
		Mapped secondary digital function – see Table 6-6	0; 1 ⁽³⁾	1	≤ 30 ⁽³⁾	0
		Output driver and input Schmitt trigger disabled	X	1	= 31	0
		S15 (not available on CC430F513x)	X	X	X	1
P3.6/P3MAP6/S16	6	P3.6 (I/O)	I: 0; O: 1	0	X	0
		Mapped secondary digital function – see Table 6-6	0; 1 ⁽³⁾	1	≤ 30 ⁽³⁾	0
		Output driver and input Schmitt trigger disabled	X	1	= 31	0
		S16 (not available on CC430F513x)	X	X	X	1
P3.7/P3MAP7/S17	7	P3.7 (I/O)	I: 0; O: 1	0	X	0
		Mapped secondary digital function – see Table 6-6	0; 1 ⁽³⁾	1	≤ 30 ⁽³⁾	0
		Output driver and input Schmitt trigger disabled	X	1	= 31	0
		S17 (not available on CC430F513x)	X	X	X	1

- (1) X = don't care
- (2) LCDSx not available in CC430F513x.
- (3) According to mapped function – see [Table 6-6](#).

6.11.5 Port P4 (P4.0 to P4.7) Input/Output With Schmitt Trigger (CC430F613x and CC430F612x Only)

Figure 6-8 shows the port diagram. Table 6-49 summarizes the selection of the pin functions.

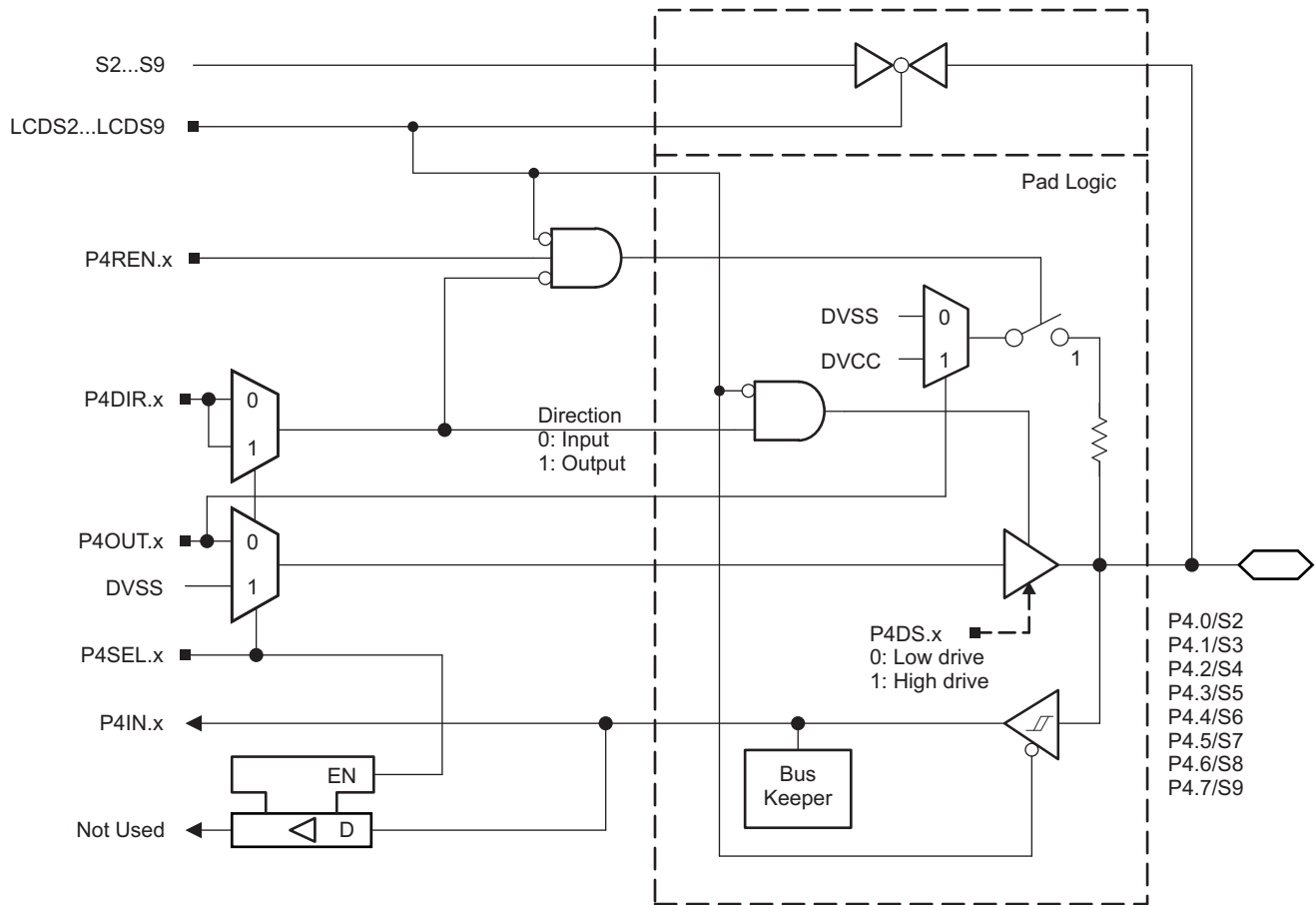

Figure 6-8. Port P4 (P4.0 to P4.7) Diagram (CC430F613x and CC430F612x Only)

Table 6-49. Port P4 (P4.0 to P4.7) Pin Functions (CC430F613x and CC430F612x Only)

PIN NAME (P4.x)	x	FUNCTION	CONTROL BITS OR SIGNALS ⁽¹⁾		
			P4DIR.x	P4SEL.x	LCDS2 to LCDS9
P4.0/P4MAP0/S2	0	P4.0 (I/O)	I: 0; O: 1	0	0
		N/A	0	1	0
		DVSS	1	1	0
		S2	X	X	1
P4.1/P4MAP1/S3	1	P4.1 (I/O)	I: 0; O: 1	0	0
		N/A	0	1	0
		DVSS	1	1	0
		S3	X	X	1
P4.2/P4MAP7/S4	2	P4.2 (I/O)	I: 0; O: 1	0	0
		N/A	0	1	0
		DVSS	1	1	0
		S4	X	X	1
P4.3/P4MAP3/S5	3	P4.3 (I/O)	I: 0; O: 1	0	0
		N/A	0	1	0
		DVSS	1	1	0
		S5	X	X	1
P4.4/P4MAP4/S6	4	P4.4 (I/O)	I: 0; O: 1	0	0
		N/A	0	1	0
		DVSS	1	1	0
		S6	X	X	1
P4.5/P4MAP5/S7	5	P4.5 (I/O)	I: 0; O: 1	0	0
		N/A	0	1	0
		DVSS	1	1	0
		S7	X	X	1
P4.6/P4MAP6/S8	6	P4.6 (I/O)	I: 0; O: 1	0	0
		N/A	0	1	0
		DVSS	1	1	0
		S8	X	X	1
P4.7/P4MAP7/S9	7	P4.7 (I/O)	I: 0; O: 1	0	0
		N/A	0	1	0
		DVSS	1	1	0
		S9	X	X	1

(1) X = don't care

6.11.6 Port P5 (P5.0 and P5.1) Input/Output With Schmitt Trigger

Figure 6-9 and Figure 6-10 show the port diagrams. Table 6-50 summarizes the selection of the pin functions.

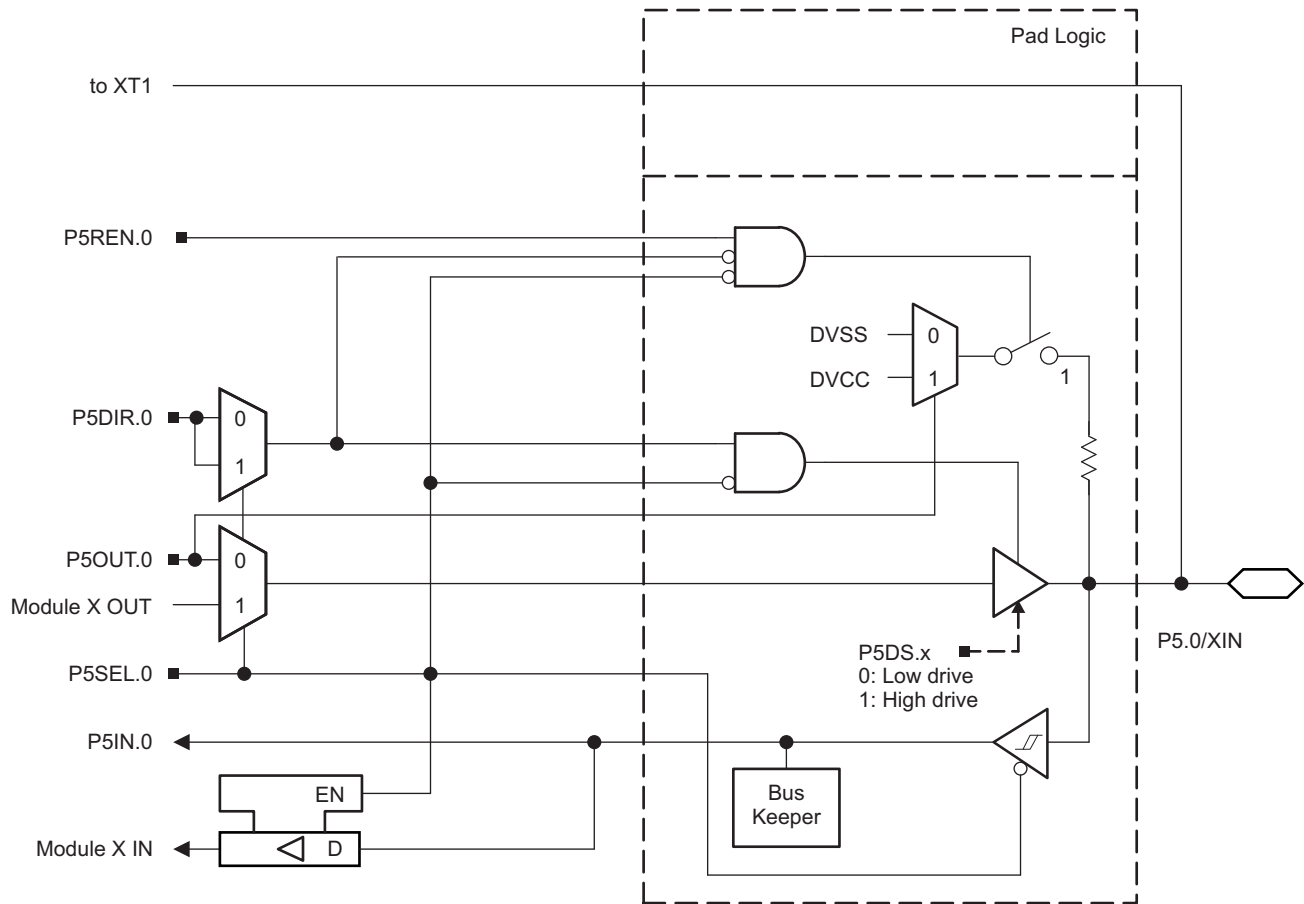

Figure 6-9. Port P5 (P5.0) Diagram

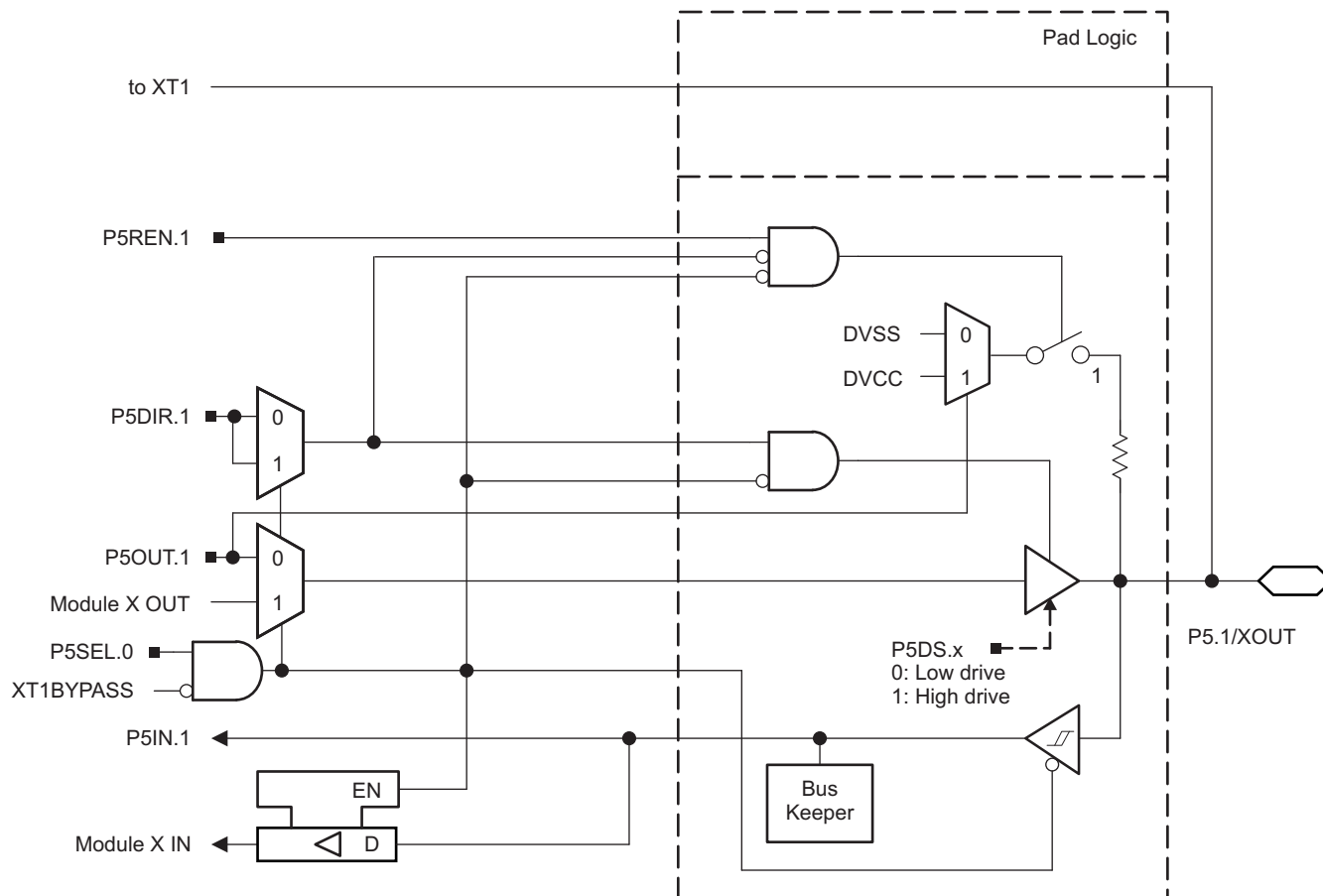

Figure 6-10. Port P5 (P5.1) Diagram

Table 6-50. Port P5 (P5.0 and P5.1) Pin Functions

PIN NAME (P5.x)	x	FUNCTION	CONTROL BITS OR SIGNALS ⁽¹⁾			
			P5DIR.x	P5SEL.0	P5SEL.1	XT1BYPASS
P5.0/XIN	0	P5.0 (I/O)	I: 0; O: 1	0	X	X
		XIN crystal mode ⁽²⁾	X	1	X	0
		XIN bypass mode ⁽²⁾	X	1	X	1
P5.1/XOUT	1	P5.1 (I/O)	I: 0; O: 1	0	X	X
		XOUT crystal mode ⁽³⁾	X	1	X	0
		P5.1 (I/O) ⁽³⁾	X	1	X	1

- (1) X = don't care
 (2) Setting P5SEL.0 causes the general-purpose I/O to be disabled. Pending the setting of XT1BYPASS, P5.0 is configured for crystal mode or bypass mode.
 (3) Setting P5SEL.0 causes the general-purpose I/O to be disabled in crystal mode. When using bypass mode, P5.1 can be used as general-purpose I/O.

6.11.7 Port P5 (P5.2 to P5.4) Input/Output With Schmitt Trigger (CC430F613x and CC430F612x Only)

Figure 6-11 shows the port diagram. Table 6-51 and Table 6-52 summarize the selection of the pin functions.

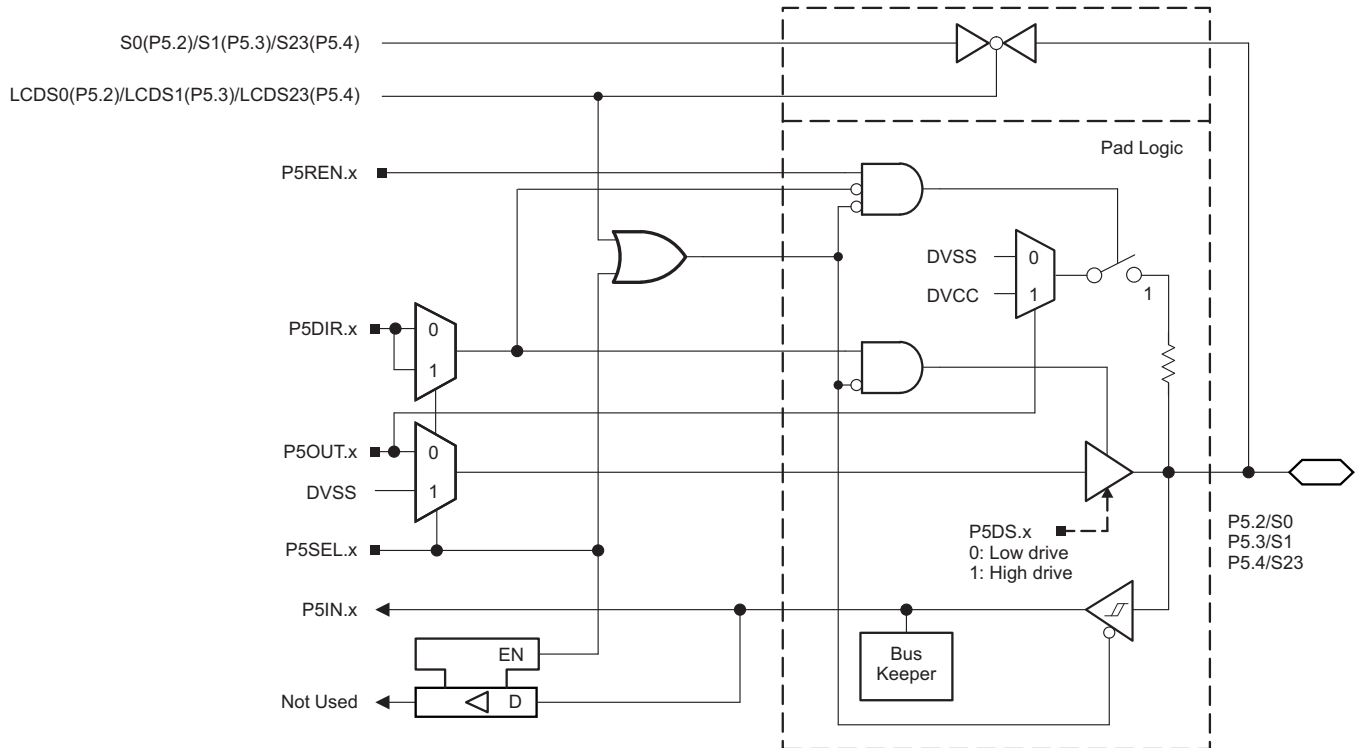

Figure 6-11. Port P5 (P5.2 to P5.4) Diagram (CC430F613x and CC430F612x Only)

Table 6-51. Port P5 (P5.2 to P5.3) Pin Functions (CC430F613x and CC430F612x Only)

PIN NAME (P5.x)	x	FUNCTION	CONTROL BITS OR SIGNALS ⁽¹⁾		
			P5DIR.x	P5SEL.x	LCDS0 to LCDS1
P5.2/S0	2	P5.2 (I/O)	I: 0; O: 1	0	0
		N/A	0	1	0
		DVSS	1	1	0
		S0	X	X	1
P5.3/S1	3	P5.3 (I/O)	I: 0; O: 1	0	0
		N/A	0	1	0
		DVSS	1	1	0
		S1	X	X	1

(1) X = don't care

Table 6-52. Port P5 (P5.4) Pin Functions (CC430F613x and CC430F612x Only)

PIN NAME (P5.x)	x	FUNCTION	CONTROL BITS OR SIGNALS ⁽¹⁾		
			P5DIR.x	P5SEL.x	LCDS23
P5.4/S23	4	P5.4 (I/O)	I: 0; O: 1	0	0
		N/A	0	1	0
		DVSS	1	1	0
		S23	X	X	1

(1) X = don't care

6.11.8 Port P5 (P5.5 to P5.7) Input/Output With Schmitt Trigger (CC430F613x and CC430F612x Only)

Figure 6-12 shows the port diagram. Table 6-53 summarizes the selection of the pin functions.

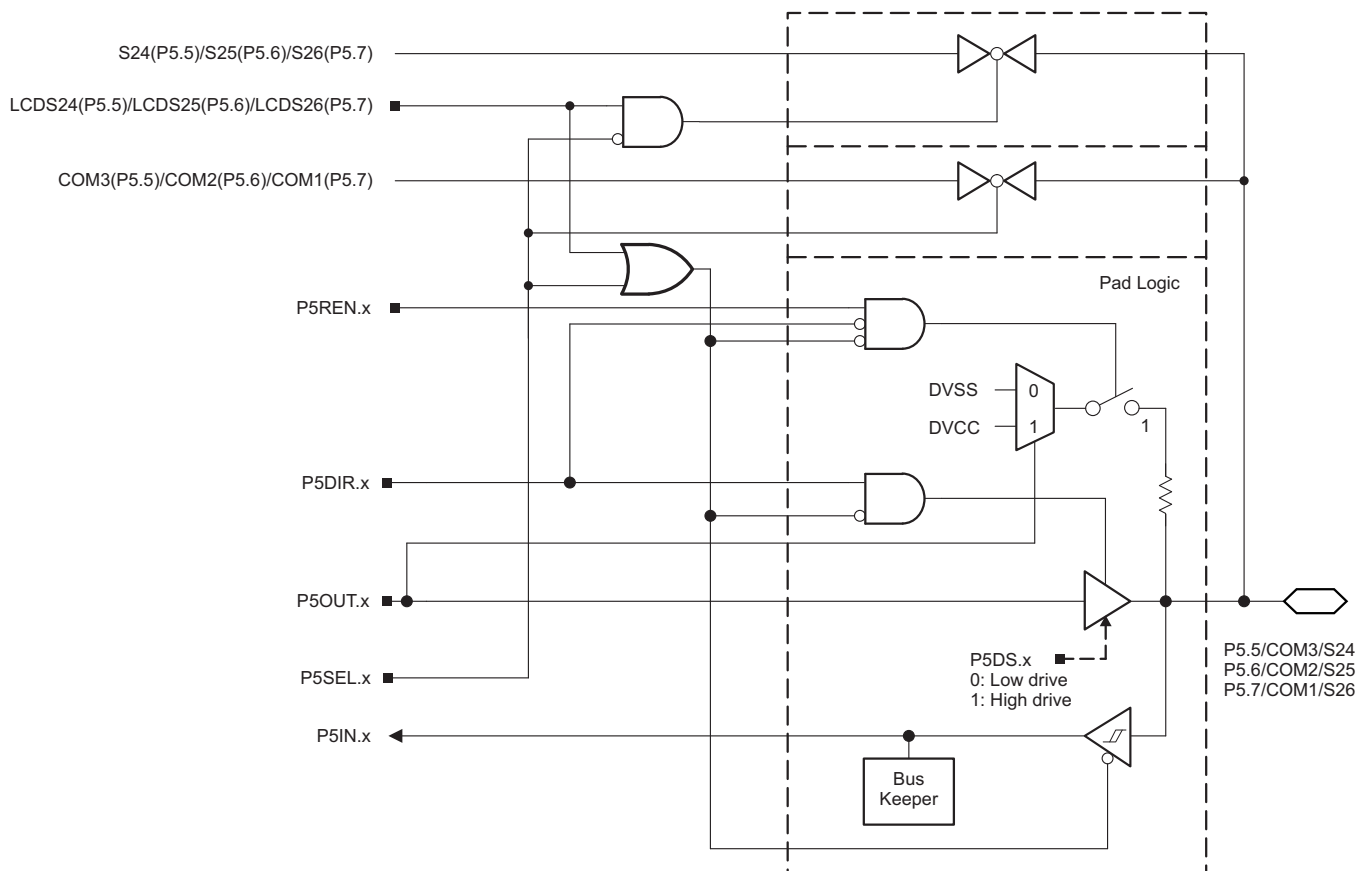

Figure 6-12. Port P5 (P5.5 to P5.7) Diagram (CC430F613x and CC430F612x Only)

Table 6-53. Port P5 (P5.5 to P5.7) Pin Functions (CC430F613x and CC430F612x Only)

PIN NAME (P5.x)	x	FUNCTION	CONTROL BITS OR SIGNALS ⁽¹⁾		
			P5DIR.x	P5SEL.x	LCDS24 to LCDS26
P5.5/COM3/S24	5	P5.5 (I/O)	I: 0; O: 1	0	0
		COM3 ⁽²⁾	X	1	X
		S24 ⁽²⁾	X	0	1
P5.6/COM2/S25	6	P5.6 (I/O)	I: 0; O: 1	0	0
		COM2 ⁽²⁾	X	1	X
		S25 ⁽²⁾	X	0	1
P5.7/COM1/S26	7	P5.7 (I/O)	I: 0; O: 1	0	0
		COM1 ⁽²⁾	X	1	X
		S26 ⁽²⁾	X	0	1

(1) X = don't care

(2) Setting P5SEL.x bit disables the output driver and the input Schmitt trigger.

6.11.9 Port J (PJ.0) JTAG Pin TDO, Input/Output With Schmitt Trigger or Output

Figure 6-13 shows the port diagram. Table 6-54 summarizes the selection of the pin functions.

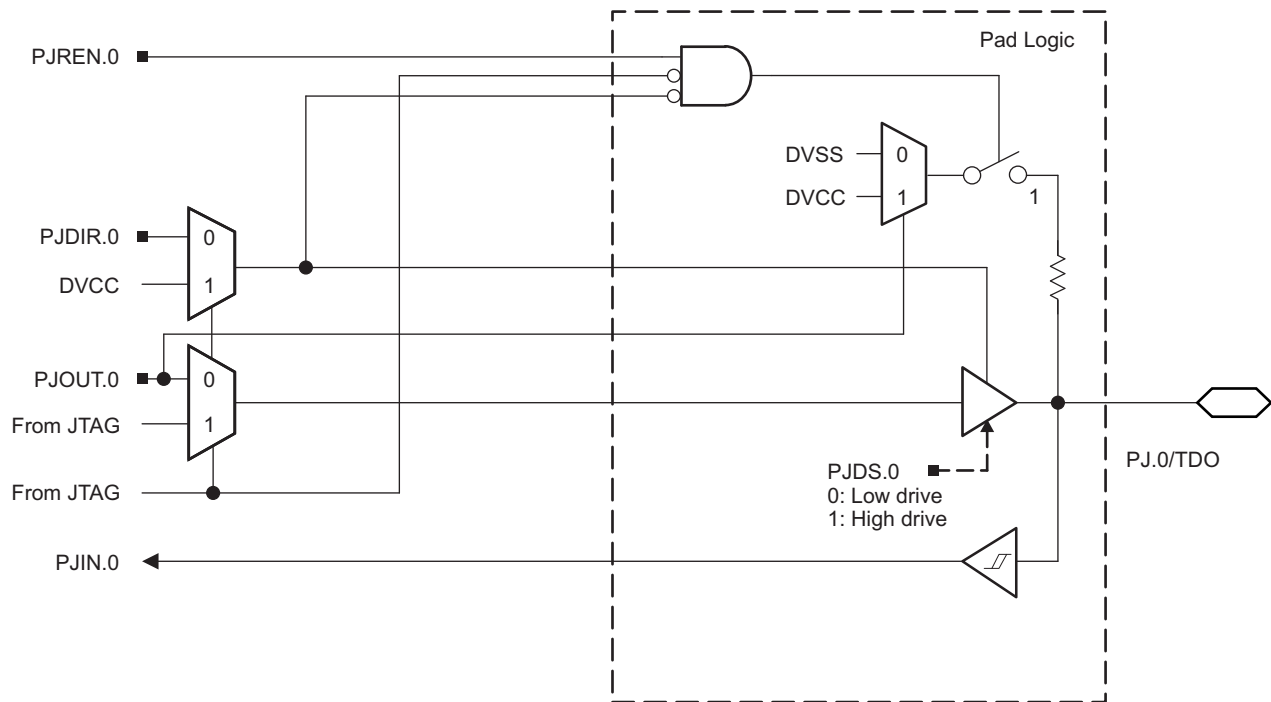

Figure 6-13. Port PJ (PJ.0) Diagram

6.11.10 Port J (PJ.1 to PJ.3) JTAG Pins TMS, TCK, TDI/TCLK, Input/Output With Schmitt Trigger or Output

Figure 6-14 shows the port diagram. Table 6-54 summarizes the selection of the pin functions.

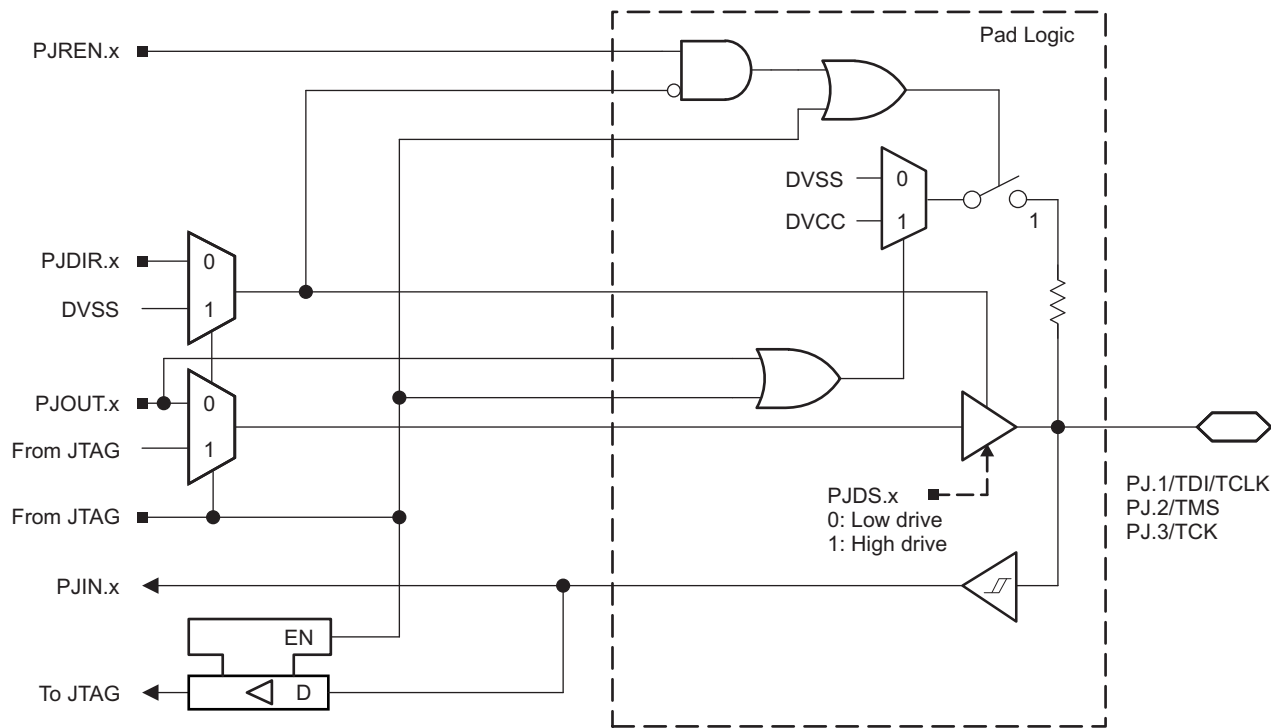

Figure 6-14. Port PJ (PJ.1 to PJ.3) Diagram

Table 6-54. Port PJ (PJ.0 to PJ.3) Pin Functions

PIN NAME (PJ.x)	x	FUNCTION	CONTROL BITS OR SIGNALS ⁽¹⁾
			PJDIR.x
PJ.0/TDO	0	PJ.0 (I/O) ⁽²⁾	I: 0; O: 1
		TDO ⁽³⁾	X
PJ.1/TDI/TCLK	1	PJ.1 (I/O) ⁽²⁾	I: 0; O: 1
		TDI/TCLK ^{(3) (4)}	X
PJ.2/TMS	2	PJ.2 (I/O) ⁽²⁾	I: 0; O: 1
		TMS ^{(3) (4)}	X
PJ.3/TCK	3	PJ.3 (I/O) ⁽²⁾	I: 0; O: 1
		TCK ^{(3) (4)}	X

- (1) X = don't care
- (2) Default condition
- (3) The pin direction is controlled by the JTAG module.
- (4) In JTAG mode, pullups are activated automatically on TMS, TCK, and TDI/TCLK. PJREN.x are do not care.

6.12 Device Descriptor

Table 6-55 lists the content of the device descriptor tag-length-value (TLV) structure for CC430F613x and CC430F513x device types.

Table 6-56 lists the content of the device descriptor tag-length-value (TLV) structure for CC430F612x device types.

Table 6-55. Device Descriptor Table (CC430F613x and CC430F513x)

DESCRIPTION	ADDRESS	SIZE (bytes)	VALUE					
			F6137	F6135	F5137	F5135	F5133	
Info Block	Info length	01A00h	1	06h	06h	06h	06h	06h
	CRC length	01A01h	1	06h	06h	06h	06h	06h
	CRC value	01A02h	2	Per unit	Per unit	Per unit	Per unit	Per unit
	Device ID	01A04h	1	61h	61h	51h	51h	51h
	Device ID	01A05h	1	37h	35h	37h	35h	33h
	Hardware revision	01A06h	1	Per unit	Per unit	Per unit	Per unit	Per unit
	Firmware revision	01A07h	1	Per unit	Per unit	Per unit	Per unit	Per unit
Die Record	Die record tag	01A08h	1	08h	08h	08h	08h	08h
	Die record length	01A09h	1	0Ah	0Ah	0Ah	0Ah	0Ah
	Lot/wafer ID	01A0Ah	4	Per unit	Per unit	Per unit	Per unit	Per unit
	Die X position	01A0Eh	2	Per unit	Per unit	Per unit	Per unit	Per unit
	Die Y position	01A10h	2	Per unit	Per unit	Per unit	Per unit	Per unit
	Test results	01A12h	2	Per unit	Per unit	Per unit	Per unit	Per unit
ADC12 Calibration	ADC12 calibration tag	01A14h	1	11h	11h	11h	11h	11h
	ADC12 calibration length	01A15h	1	10h	10h	10h	10h	10h
	ADC gain factor	01A16h	2	Per unit	Per unit	Per unit	Per unit	Per unit
	ADC offset	01A18h	2	Per unit	Per unit	Per unit	Per unit	Per unit
	ADC 1.5-V reference Temperature sensor 30°C	01A1Ah	2	Per unit	Per unit	Per unit	Per unit	Per unit
	ADC 1.5-V reference Temperature sensor 85°C	01A1Ch	2	Per unit	Per unit	Per unit	Per unit	Per unit
	ADC 2.0-V reference Temperature sensor 30°C	01A1Eh	2	Per unit	Per unit	Per unit	Per unit	Per unit
	ADC 2.0-V reference Temperature sensor 85°C	01A20h	2	Per unit	Per unit	Per unit	Per unit	Per unit
	ADC 2.5-V reference Temperature sensor 30°C	01A22h	2	Per unit	Per unit	Per unit	Per unit	Per unit
	ADC 2.5-V reference Temperature sensor 85°C	01A24h	2	Per unit	Per unit	Per unit	Per unit	Per unit
REF Calibration	REF calibration tag	01A26h	1	12h	12h	12h	12h	12h
	REF calibration length	01A27h	1	06h	06h	06h	06h	06h
	1.5-V reference factor	01A28h	2	Per unit	Per unit	Per unit	Per unit	Per unit
	2.0-V reference factor	01A2Ah	2	Per unit	Per unit	Per unit	Per unit	Per unit
	2.5-V reference factor	01A2Ch	2	Per unit	Per unit	Per unit	Per unit	Per unit
Peripheral Descriptor (PD)	Peripheral descriptor tag	01A2Eh	1	02h	02h	02h	02h	02h
	Peripheral descriptor length	01A2Fh	1	57h	57h	55h	55h	55h
	Peripheral descriptors	01A30h	PD Length

Table 6-56. Device Descriptor Table (CC430F612x)

DESCRIPTION		ADDRESS	SIZE (bytes)	VALUE		
				F6127	F6126	F6125
Info Block	Info length	01A00h	1	06h	06h	06h
	CRC length	01A01h	1	06h	06h	06h
	CRC value	01A02h	2	Per unit	Per unit	Per unit
	Device ID	01A04h	1	61h	61h	61h
	Device ID	01A05h	1	27h	26h	25h
	Hardware revision	01A06h	1	Per unit	Per unit	Per unit
	Firmware revision	01A07h	1	Per unit	Per unit	Per unit
Die Record	Die record tag	01A08h	1	08h	08h	08h
	Die record length	01A09h	1	0Ah	0Ah	0Ah
	Lot/wafer ID	01A0Ah	4	Per unit	Per unit	Per unit
	Die X position	01A0Eh	2	Per unit	Per unit	Per unit
	Die Y position	01A10h	2	Per unit	Per unit	Per unit
	Test results	01A12h	2	Per unit	Per unit	Per unit
Empty Descriptor	Empty tag	01A14h	1	05h	05h	05h
	Empty tag length	01A15h	1	10h	10h	10h
		01A16h	16	undefined	undefined	undefined
REF Calibration	REF calibration I	01A26h	1	12h	12h	12h
	REF calibration length	01A27h	1	06h	06h	06h
	1.5-V reference factor	01A28h	2	Per unit	Per unit	Per unit
	2.0-V reference factor	01A2Ah	2	Per unit	Per unit	Per unit
	2.5-V reference factor	01A2Ch	2	Per unit	Per unit	Per unit
Peripheral Descriptor (PD)	Peripheral descriptor tag	01A2Eh	1	02h	02h	02h
	Peripheral descriptor length	01A2Fh	1	55h	55h	55h
	Peripheral descriptors	01A30h	PD Length

7 Applications, Implementation, and Layout

NOTE

Information in the following Applications section is not part of the TI component specification, and TI does not warrant its accuracy or completeness. TI's customers are responsible for determining suitability of components for their purposes. Customers should validate and test their design implementation to confirm system functionality.

7.1 Application Circuits

[Figure 7-1](#) shows a typical application circuit for the CC430F61xx. [Table 7-1](#) lists the bill of materials.

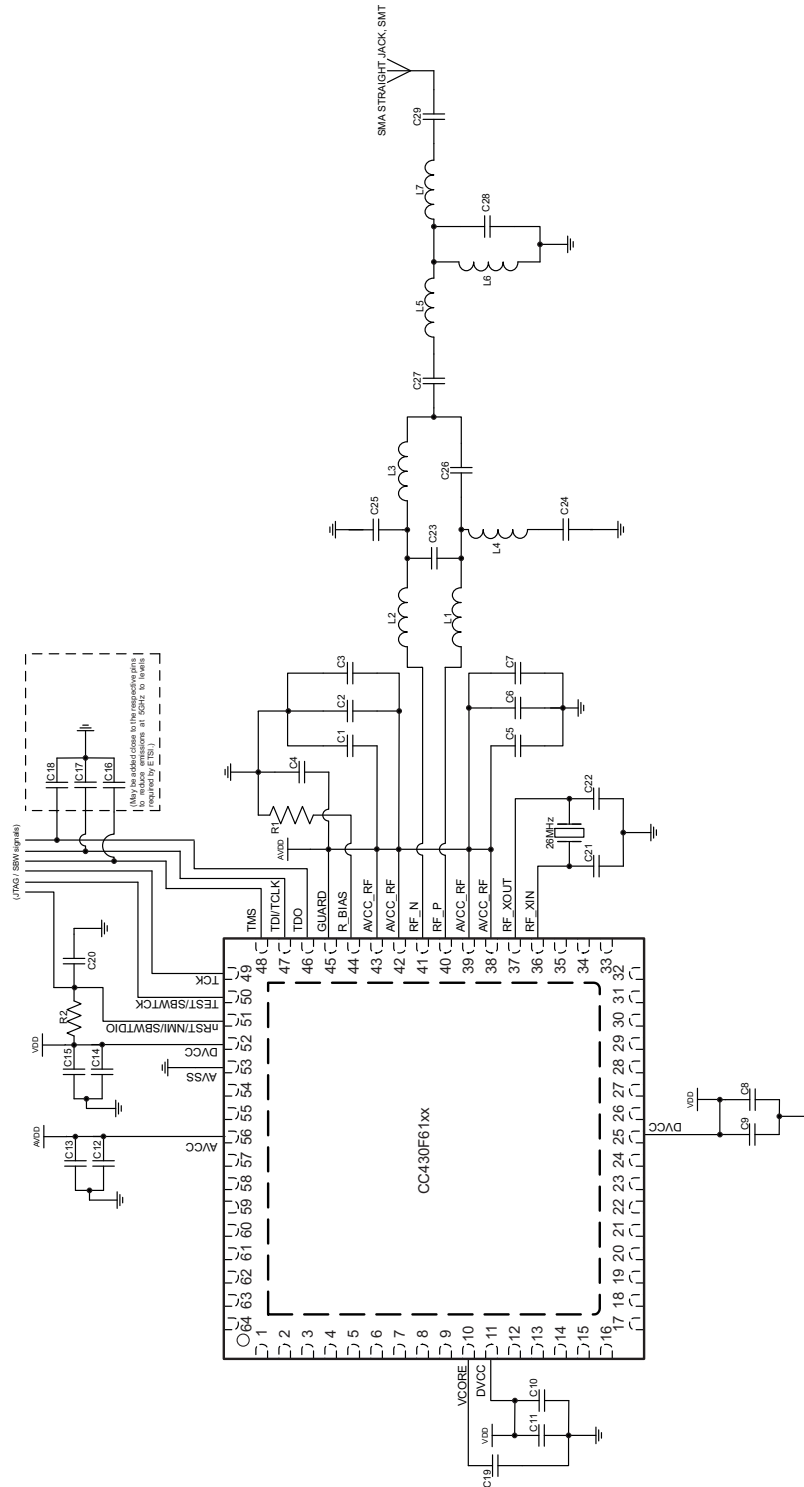

Copyright © 2017, Texas Instruments Incorporated

For a complete reference design including layout, see the [CC430 wireless development tools](#) and the [MSP430 Hardware Tools User's Guide](#).

Figure 7-1. Typical Application Circuit CC430F61xx

Figure 7-2 shows a typical application circuit for the CC430F51xx. Table 7-1 lists the bill of materials.

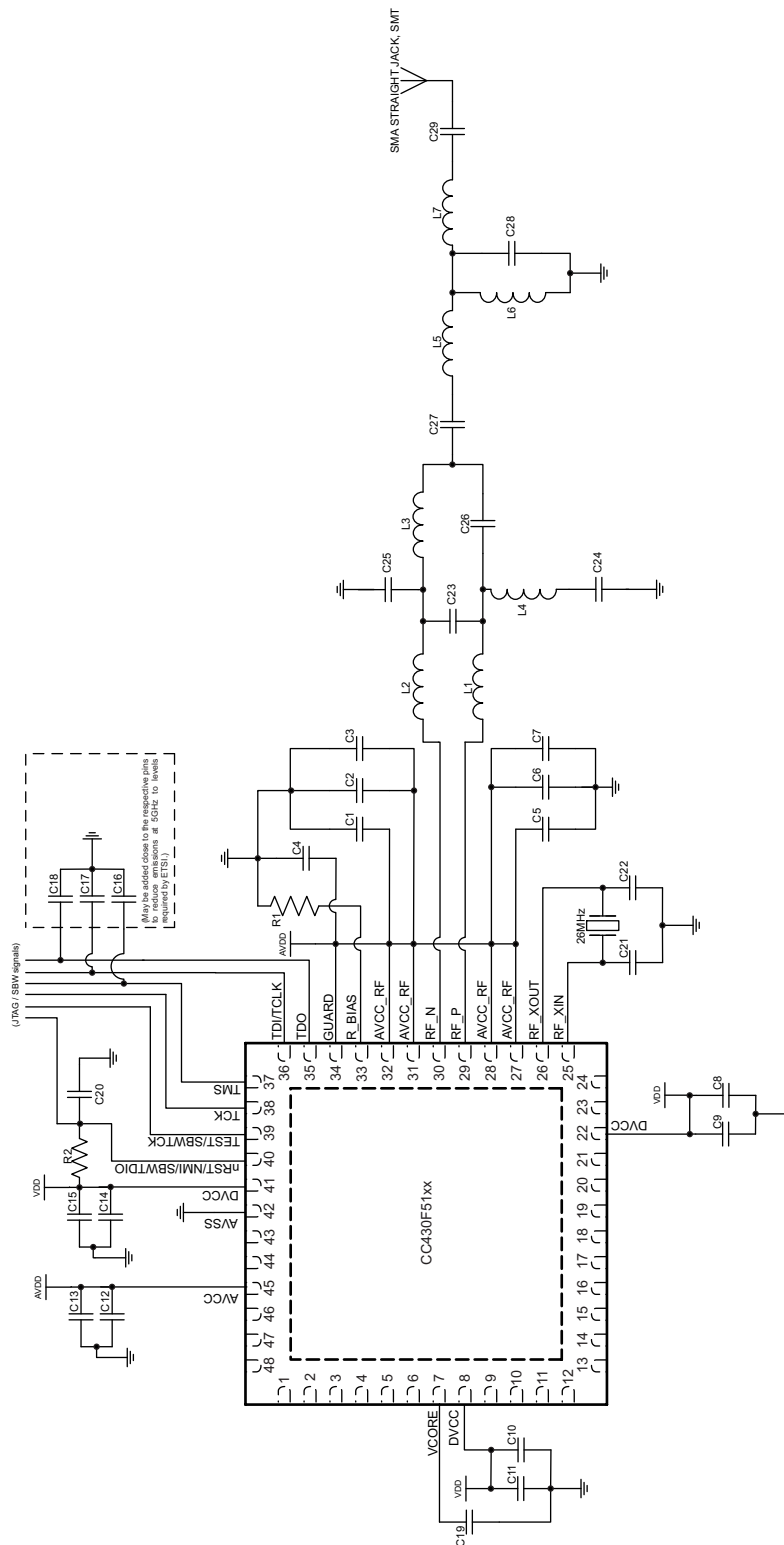

Copyright © 2017, Texas Instruments Incorporated

For a complete reference design including layout, see the [CC430 wireless development tools](#) and the [MSP430 Hardware Tools User's Guide](#).

Figure 7-2. Typical Application Circuit CC430F51xx

Table 7-1. Bill of Materials

Components	For 315 MHz	For 433 MHz	For 868 or 915 MHz	Comment
C1, C3, C4, C5, C7, C9, C11, C13, C15		100 nF		Decoupling capacitors
C8, C10, C12, C14		10 µF		Decoupling capacitors
C2, C6, C16, C17, C18		2 pF		Decoupling capacitors
C19		470 nF		V _{CORE} capacitor
C20		2.2 nF		$\overline{\text{RST}}$ decoupling cap (optimized for SBW)
C21, C22		27 pF		Load capacitors for 26 MHz crystal ⁽¹⁾
R1		56 kΩ		R_BIAS (±1% required)
R2		47 kΩ		$\overline{\text{RST}}$ pullup
L1, L2	Capacitors: 220 pF	0.016 µH	0.012 µH	
L3, L4	0.033 µH	0.027 µH	0.018 µH	
L5	0.033 µH	0.047 µH	0.015 µH	
L6	dnp ⁽²⁾	dnp ⁽²⁾	0.0022 µH	
L7	0.033 µH	0.051 µH	0.015 µH	
C23	dnp ⁽²⁾	2.7 pF	1 pF	
C24	220 pF	220 pF	100 pF	
C25	6.8 pF	3.9 pF	1.5 pF	
C26	6.8 pF	3.9 pF	1.5 pF	
C27	220 pF	220 pF	1.5 pF	
C28	10 pF	4.7 pF	8.2 pF	
C29	220 pF	220 pF	1.5 pF	

(1) The load capacitance C_L seen by the crystal is $C_L = 1 / ((1 / C21) + (1 / C22)) + C_{\text{parasitic}}$. The parasitic capacitance C_{parasitic} includes pin capacitance and PCB stray capacitance. It can typically be estimated to be approximately 2.5 pF.

(2) dnp = do not populate

8 器件和文档支持

8.1 入门和后续步骤

有关 MSP430™ 系列器件、工具和库相关信息，请访问[入门页面](#)。

8.2 Device Nomenclature

To designate the stages in the product development cycle, TI assigns prefixes to the part numbers of all MSP MCU devices. Each MSP MCU commercial family member has one of two prefixes: MSP or XMS. These prefixes represent evolutionary stages of product development from engineering prototypes (XMS) through fully qualified production devices (MSP).

XMS – Experimental device that is not necessarily representative of the final device's electrical specifications

MSP – Fully qualified production device

XMS devices are shipped against the following disclaimer:

"Developmental product is intended for internal evaluation purposes."

MSP devices have been characterized fully, and the quality and reliability of the device have been demonstrated fully. TI's standard warranty applies.

Predictions show that prototype devices (XMS) have a greater failure rate than the standard production devices. TI recommends that these devices not be used in any production system because their expected end-use failure rate still is undefined. Only qualified production devices are to be used.

TI device nomenclature also includes a suffix with the device family name. This suffix indicates the temperature range, package type, and distribution format. [图 8-1](#) provides a legend for reading the complete device name.

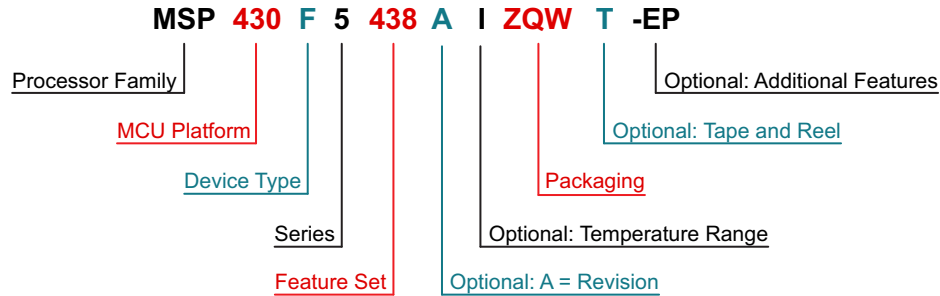

Processor Family	CC = Embedded RF Radio MSP = Mixed-Signal Processor XMS = Experimental Silicon PMS = Prototype Device	
MCU Platform	430 = MSP430 low-power microcontroller platform	
Device Type	Memory Type C = ROM F = Flash FR = FRAM G = Flash or FRAM (Value Line) L = No Nonvolatile Memory	Specialized Application AFE = Analog Front End BQ = Contactless Power CG = ROM Medical FE = Flash Energy Meter FG = Flash Medical FW = Flash Electronic Flow Meter
Series	1 = Up to 8 MHz 2 = Up to 16 MHz 3 = Legacy 4 = Up to 16 MHz with LCD	5 = Up to 25 MHz 6 = Up to 25 MHz with LCD 0 = Low-Voltage Series
Feature Set	Various levels of integration within a series	
Optional: A = Revision	N/A	
Optional: Temperature Range	S = 0°C to 50°C C = 0°C to 70°C I = -40°C to 85°C T = -40°C to 105°C	
Packaging	http://www.ti.com/packaging	
Optional: Tape and Reel	T = Small reel R = Large reel No markings = Tube or tray	
Optional: Additional Features	-EP = Enhanced Product (-40°C to 105°C) -HT = Extreme Temperature Parts (-55°C to 150°C) -Q1 = Automotive Q100 Qualified	

图 8-1. Device Nomenclature

8.3 工具和软件

多种软件和硬件开发工具都支持 CC430 微控制器。相关工具由 TI 以及多家第三方供应商提供。

设计套件与评估模块

CC430 低于 1GHz 射频实验板 MSP-EXPCC430RFx 实验板套件是一款完整的低于 1GHz 开发平台，适用于 MSP430 超低功耗微控制器系列中的 CC430 器件。此套件提供了两个低于 1GHz 无线模块：MSP-EXP430F6137Rx 基板（带 CC430F6137）和 MSP-EXP430F5137Rx 卫星板（带 CC430F5137）。

Chronos: 无线手表开发工具 eZ430-Chronos 是运动手表中基于 CC430 的高度集成式可穿戴无线开发系统。它可用作手表系统的参考平台、针对个人局域网的个人显示器或者作为远程数据采集的无线传感器节点。

低于 1GHz 射频频谱分析仪工具 MSP-SA430 低于 1GHz 频谱分析仪是一款基于 CC430 的参考设计，可用于实施一款简单实惠的工具，以帮助快速启动低于 1GHz 频率范围内的射频开发。越来越多的电子器件集成了内置射频链路。射频收发器本身成本并不高，但用于设计和调试这类系统的设备却价格不菲。基于 CC430 的频谱分析仪是一种经济实惠的开发工具，利用该工具可减少开发贵重测量设备所需要的时间。

软件

MSP430Ware™ 软件 MSP430Ware 软件集合了所有 MSP430 器件的代码示例、数据表以及其他设计资源，打包提供给用户。除了提供已有 MSP430 设计资源的完整集合外，MSP430Ware 软件还包含名为 MSP 驱动程序库的高级 API。借助该库可以轻松地对 MSP430 硬件进行编程。MSP430Ware 软件以 CCS 组件或独立软件包两种形式提供。

CC430F613x 代码示例 根据不同应用需求配置各集成外设的 C 代码示例。

ULP (超低功耗) Advisor ULP (超低功耗) Advisor 是一款辅助工具，旨在指导开发人员编写更为高效的代码，从而充分利用 MSP 和 MSP432 微控制器独特的超低功耗功能。ULP Advisor 的目标用户是微控制器的资深开发者和开发新手，可以根据详尽的 ULP 检验表检查代码，以便以最低的功耗最大限度地利用应用。

开发工具

适用于 MSP 微控制器的 Code Composer Studio™ 集成开发环境 Code Composer Studio 是一种集成开发环境 (IDE)，支持所有 MSP 微控制器。Code Composer Studio 包含一整套开发和调试嵌入式应用的嵌入式软件实用程序的工具。它包含了优化的 C/C++ 编译器、源代码编辑器、项目构建环境、调试器、描述器以及其他多种功能。

GCC - 适用于 MSP430 微控制器的开源编译器 TI 与 Red Hat 合作为您带来得到全面支持的新开源编译器，它是由社区推动的 MSPGCC 的升级版产品。此免费 GCC 4.9 编译器支持所有 MSP430 器件且没有代码大小限制。此外，此编译器可以通过命令行独立使用，也可在 Code Composer Studio v6.0 或更高版本中选择。

MSP MCU 编程器和调试器 MSP-FET 是一款强大的仿真开发工具（通常称为调试探针），可帮助用户在 MSP 低功耗微控制器 (MCU) 中快速开发应用。

MSP-GANG 生产编程器 MSP Gang 编程器是一种器件编程器，可同时对多达八个完全相同的器件进行编程。MSP Gang 编程器可使用标准的 RS-232 或 USB 连接与主机 PC 相连并提供灵活的编程选项，允许用户完全自定义流程。

8.4 文档支持

以下文档介绍了 CC430F613x、CC430F612x 和 CC430F513x 器件。www.ti.com.cn 网站上提供了这些文档的副本。

接收文档更新通知

如需接收文档更新通知（包括器件勘误表），请转至 ti.com.cn 上相关器件的产品文件夹（关于这些产品文件夹的链接，请参阅节 8.5）。请单击右上角的“通知我”按钮。点击注册后，即可收到产品信息更改每周摘要（如有）。有关更改的详细信息，请查阅已修订文档的修订历史记录。

勘误

- 《[CC430F6137 器件勘误表](#)》 介绍功能规格的已知例外情况。
- 《[CC430F6135 器件勘误表](#)》 介绍功能规格的已知例外情况。
- 《[CC430F6127 器件勘误表](#)》 介绍功能规格的已知例外情况。
- 《[CC430F6126 器件勘误表](#)》 介绍功能规格的已知例外情况。
- 《[CC430F6125 器件勘误表](#)》 介绍功能规格的已知例外情况。
- 《[CC430F5137 器件勘误表](#)》 介绍功能规格的已知例外情况。
- 《[CC430F5135 器件勘误表](#)》 介绍功能规格的已知例外情况。
- 《[CC430F5133 器件勘误表](#)》 介绍功能规格的已知例外情况。

用户指南

CC430 系列产品用户指南 详细介绍了该器件系列提供的模块和外设。

《[适用于 MSP430 的 Code Composer Studio 用户指南](#)》 此用户指南介绍如何将 TI Code Composer Studio IDE 与 MSP430 超低功耗微控制器结合使用。

《[MSP430™ 闪存器件引导加载程序 \(BSL\) 用户指南](#)》 MSP430 引导加载程序 (BSL, 之前称为引导装载程序) 方便用户在原型建模阶段、最终生产和维修期间与 MSP430 微控制器中的嵌入式存储器进行通信。可编程存储器 (闪存) 和数据存储器 (RAM) 能够按照要求进行变更。不要将此处的引导加载程序与某些数字信号处理器 (DSP) 中将外部存储器中的程序代码 (和数据) 自动加载到 DSP 内部存储器的引导装载程序混为一谈。

《[通过 JTAG 接口对 MSP430 进行编程](#)》 此文档介绍了使用 JTAG 通信端口擦除、编程和验证基于 MSP430 闪存和 FRAM 的微控制器系列的存储器模块所需的功能。此外，该文档还介绍了如何编程所有 MSP430 器件上均具备的 JTAG 访问安全保险丝。此文档介绍了使用标准四线制 JTAG 接口和两线制 JTAG 接口 (也称为 Spy-Bi-Wire (SBW)) 的器件访问。

《[MSP430 硬件工具用户指南](#)》 此手册介绍了 TI MSP-FET430 闪存仿真工具 (FET) 的硬件。FET 是针对 MSP430 超低功耗微控制器的程序开发工具。文中对提供的接口类型，即并行端口接口和 USB 接口进行了说明。

应用报告

《[MSP430 32kHz 晶体振荡器](#)》 选择合适的晶体、正确的负载电路和适当的电路板布局是实现稳定的晶体振荡器的关键。该应用报告总结了晶体振荡器的功能，介绍了用于选择合适的晶体以实现 MSP430 超低功耗运行的参数。此外，还给出了正确电路板布局的提示和示例。此外，为了确保振荡器在大规模生产后能够稳定运行，还可能需要进行一些振荡器测试，该文档中提供了有关这些测试的详细信息。

《[MSP430 系统级 ESD 注意事项](#)》 系统级 ESD 对于低电压下的硅晶技术以及经济高效型和超低功耗组件的需求日益增加。此应用报告重点讨论了三个不同的 ESD 主题，以帮助板卡设计师和原始设备制造商 (OEM) 理解和设计稳健的系统级设计产品：(1) 组件级 ESD 测试和系统级 ESD 测试，二者的差异以及为何组件级 ESD 无法确保达到系统级的稳健性。(2) 系统级 ESD 保护在不同电平下的通用设计指南 (包括外壳、电缆、PCB 布局和板载 ESD 防护器件)。(3) 介绍了系统高效 ESD 设计 (SEED)。这是一种板上和片上 ESD 保护协同设计的方法论，用于实现系统级 ESD 的稳健性，配备仿真示例和测试结果。另外，还讨论了一些真实的系统级 ESD 保护设计示例及其成果。

DN005 CC11xx 灵敏度与频率偏移和晶体精度间的关系 此设计注释提供了不同数据速率下 CC11xx (CC1100、CC1100E、CC1101、CC1110 和 CC1111) 灵敏度与频率偏移间的关系图。所需的晶体精度通过这些图进行计算。结果同样适用于 CC430。

AN050 在欧洲 868MHz SRD 频段下使用 CC1101 CC1101 是一款非常灵活且高度集成的射频接发器，且

成本非常低廉。CC1101 专为 315、433、868 和 915MHz SRD/ISM 频段中的低功耗应用而设计。此应用手册介绍了如何在欧洲 863 – 870MHz SRD 频段中使用 CC1101，以符合 EN 300 220 标准的要求。此应用手册还适用于 CC1110、CC1111 和 CC430 SoC，因为这些器件使用与 CC1101 相同的无线电。

DN010 使用 CC1101 实现近距离接收 此文档介绍了如何在近距离 应用中使用 CC1100E 和 CC1101。在 250kbps 时，这些芯片的饱和限制约为 -15dBm ，对于某些短距离 应用可能会面临挑战。文中给出了两项建议解决方案，第一个是双传输方案，第二个是在近距离接收过程中改变收发器动态范围。

DN013 CC1101 上的可编程输出功率 CC1101 RF 输出功率级由 PATABLE 寄存器设置来设定。此寄存器设置还会影响不同谐波的功率级以及器件的电流消耗。因此，在选择最佳寄存器设置时必须考虑这些参数。此文档提供了完整的 CC1101 PA 表格，其中包含在 25°C 和 3.0V 电源电压下不同寄存器设置所对应的典型输出功率、谐波和电流消耗。

DN017 CC11xx 868/915MHz 射频匹配 此设计注释简要介绍了使用 CC11xx 器件进行产品设计时的射频匹配和重要方面。由于所有 CC11xx 器件都具有相同的射频前端，因此可在无线电和天线之间使用同一个匹配网络。TI 针对所有 CC11xx 产品提供参考设计。这些参考设计显示了匹配网络中去耦电容器和组件的建议位置和值。

8.5 相关链接

表 8-1 列出了快速访问链接。类别包括技术文档、支持与社区资源、工具和软件，以及申请样片或购买产品的快速链接。

表 8-1. 相关链接

器件	产品文件夹	立即订购	技术文档	工具与软件	支持和社区
CC430F6137	请单击此处	请单击此处	请单击此处	请单击此处	请单击此处
CC430F6135	请单击此处	请单击此处	请单击此处	请单击此处	请单击此处
CC430F6127	请单击此处	请单击此处	请单击此处	请单击此处	请单击此处
CC430F6126	请单击此处	请单击此处	请单击此处	请单击此处	请单击此处
CC430F6125	请单击此处	请单击此处	请单击此处	请单击此处	请单击此处
CC430F5137	请单击此处	请单击此处	请单击此处	请单击此处	请单击此处
CC430F5135	请单击此处	请单击此处	请单击此处	请单击此处	请单击此处
CC430F5133	请单击此处	请单击此处	请单击此处	请单击此处	请单击此处

8.6 社区资源

下列链接提供到 TI 社区资源的连接。链接的内容由各个分销商“按照原样”提供。这些内容并不构成 TI 技术规范，并且不一定反映 TI 的观点；请参见 TI 的《使用条款》。

TI E2E™ 社区

TI 的工程师交流 (E2E) 社区。此社区的创建目的是为了促进工程师之间协作。在 e2e.ti.com 中，您可以提问、共享知识、拓展思路，在同领域工程师的帮助下解决问题。

TI 嵌入式处理器维基网页

德州仪器 (TI) 嵌入式处理器维基网页。此网站的建立是为了帮助开发人员熟悉德州仪器 (TI) 的嵌入式处理器，并且也为了促进与这些器件相关的硬件和软件的总体知识的创新和增长。

8.7 商标

MSP430, MSP430Ware, E2E are trademarks of Texas Instruments.
All other trademarks are the property of their respective owners.

8.8 静电放电警告



ESD 可能会损坏该集成电路。德州仪器 (TI) 建议通过适当的预防措施处理所有集成电路。如果不遵守正确的处理措施和安装程序，可能会损坏集成电路。

ESD 的损坏小至导致微小的性能降级，大至整个器件故障。精密的集成电路可能更容易受到损坏，这是因为非常细微的参数更改都可能会导致器件与其发布的规格不相符。

8.9 Export Control Notice

Recipient agrees to not knowingly export or re-export, directly or indirectly, any product or technical data (as defined by the U.S., EU, and other Export Administration Regulations) including software, or any controlled product restricted by other applicable national regulations, received from disclosing party under nondisclosure obligations (if any), or any direct product of such technology, to any destination to which such export or re-export is restricted or prohibited by U.S. or other applicable laws, without obtaining prior authorization from U.S. Department of Commerce and other competent Government authorities to the extent required by those laws.

8.10 Glossary

TI Glossary This glossary lists and explains terms, acronyms, and definitions.

9 机械，封装和可订购信息

以下页中包括机械、封装和可订购信息。这些信息是指定器件的最新可用数据。数据如有变更，恕不另行通知，且不会对此文档进行修订。如需获取此数据表的浏览器版本，请查阅左侧的导航栏。

PACKAGING INFORMATION

Orderable part number	Status (1)	Material type (2)	Package Pins	Package qty Carrier	RoHS (3)	Lead finish/ Ball material (4)	MSL rating/ Peak reflow (5)	Op temp (°C)	Part marking (6)
CC430F5133IRGZ	Active	Production	VQFN (RGZ) 48	52 TUBE	Yes	NIPDAU	Level-3-260C-168 HR	-40 to 85	CC430 F5133
CC430F5133IRGZR	Active	Production	VQFN (RGZ) 48	2500 LARGE T&R	Yes	NIPDAU	Level-3-260C-168 HR	-40 to 85	CC430 F5133
CC430F5133IRGZT	Active	Production	VQFN (RGZ) 48	250 SMALL T&R	Yes	NIPDAU	Level-3-260C-168 HR	-40 to 85	CC430 F5133
CC430F5135IRGZ	Active	Production	VQFN (RGZ) 48	52 TUBE	Yes	NIPDAU	Level-3-260C-168 HR	-40 to 85	CC430 F5135
CC430F5135IRGZR	Active	Production	VQFN (RGZ) 48	2500 LARGE T&R	Yes	NIPDAU	Level-3-260C-168 HR	-40 to 85	CC430 F5135
CC430F5135IRGZT	Active	Production	VQFN (RGZ) 48	250 SMALL T&R	Yes	NIPDAU	Level-3-260C-168 HR	-40 to 85	CC430 F5135
CC430F5137IRGZ	Active	Production	VQFN (RGZ) 48	52 TUBE	Yes	NIPDAU	Level-3-260C-168 HR	-40 to 85	CC430 F5137
CC430F5137IRGZR	Active	Production	VQFN (RGZ) 48	2500 LARGE T&R	Yes	NIPDAU	Level-3-260C-168 HR	-40 to 85	CC430 F5137
CC430F5137IRGZT	Active	Production	VQFN (RGZ) 48	250 SMALL T&R	Yes	NIPDAU	Level-3-260C-168 HR	-40 to 85	CC430 F5137
CC430F6125IRGCR	Active	Production	VQFN (RGC) 64	2000 LARGE T&R	Yes	NIPDAU NIPDAUAG	Level-3-260C-168 HR	-40 to 85	CC430F6125
CC430F6126IRGCR	Active	Production	VQFN (RGC) 64	2000 LARGE T&R	Yes	NIPDAU NIPDAUAG	Level-3-260C-168 HR	-40 to 85	CC430F6126
CC430F6127IRGCR	Active	Production	VQFN (RGC) 64	2000 LARGE T&R	Yes	NIPDAU NIPDAUAG	Level-3-260C-168 HR	-40 to 85	CC430F6127
CC430F6127IRGCT	Active	Production	VQFN (RGC) 64	250 SMALL T&R	Yes	NIPDAU NIPDAUAG	Level-3-260C-168 HR	-40 to 85	CC430F6127
CC430F6135IRGCR	Active	Production	VQFN (RGC) 64	2000 LARGE T&R	Yes	NIPDAU NIPDAUAG	Level-3-260C-168 HR	-40 to 85	CC430F6135
CC430F6137IRGCR	Active	Production	VQFN (RGC) 64	2000 LARGE T&R	Yes	NIPDAU NIPDAUAG	Level-3-260C-168 HR	-40 to 85	CC430F6137
CC430F6137IRGCT	Active	Production	VQFN (RGC) 64	250 SMALL T&R	Yes	NIPDAU NIPDAUAG	Level-3-260C-168 HR	-40 to 85	CC430F6137

(1) **Status:** For more details on status, see our [product life cycle](#).

(2) **Material type:** When designated, preproduction parts are prototypes/experimental devices, and are not yet approved or released for full production. Testing and final process, including without limitation quality assurance, reliability performance testing, and/or process qualification, may not yet be complete, and this item is subject to further changes or possible discontinuation. If available for ordering, purchases will be subject to an additional waiver at checkout, and are intended for early internal evaluation purposes only. These items are sold without warranties of any kind.

(3) **RoHS values:** Yes, No, RoHS Exempt. See the [TI RoHS Statement](#) for additional information and value definition.

(4) **Lead finish/Ball material:** Parts may have multiple material finish options. Finish options are separated by a vertical ruled line. Lead finish/Ball material values may wrap to two lines if the finish value exceeds the maximum column width.

(5) **MSL rating/Peak reflow:** The moisture sensitivity level ratings and peak solder (reflow) temperatures. In the event that a part has multiple moisture sensitivity ratings, only the lowest level per JEDEC standards is shown. Refer to the shipping label for the actual reflow temperature that will be used to mount the part to the printed circuit board.

(6) **Part marking:** There may be an additional marking, which relates to the logo, the lot trace code information, or the environmental category of the part.

Multiple part markings will be inside parentheses. Only one part marking contained in parentheses and separated by a "~" will appear on a part. If a line is indented then it is a continuation of the previous line and the two combined represent the entire part marking for that device.

Important Information and Disclaimer:The information provided on this page represents TI's knowledge and belief as of the date that it is provided. TI bases its knowledge and belief on information provided by third parties, and makes no representation or warranty as to the accuracy of such information. Efforts are underway to better integrate information from third parties. TI has taken and continues to take reasonable steps to provide representative and accurate information but may not have conducted destructive testing or chemical analysis on incoming materials and chemicals. TI and TI suppliers consider certain information to be proprietary, and thus CAS numbers and other limited information may not be available for release.

In no event shall TI's liability arising out of such information exceed the total purchase price of the TI part(s) at issue in this document sold by TI to Customer on an annual basis.

TAPE AND REEL INFORMATION

QUADRANT ASSIGNMENTS FOR PIN 1 ORIENTATION IN TAPE

*All dimensions are nominal

Device	Package Type	Package Drawing	Pins	SPQ	Reel Diameter (mm)	Reel Width W1 (mm)	A0 (mm)	B0 (mm)	K0 (mm)	P1 (mm)	W (mm)	Pin1 Quadrant
CC430F5133IRGZR	VQFN	RGZ	48	2500	330.0	16.4	7.3	7.3	1.5	12.0	16.0	Q2
CC430F5135IRGZR	VQFN	RGZ	48	2500	330.0	16.4	7.3	7.3	1.5	12.0	16.0	Q2
CC430F5137IRGZR	VQFN	RGZ	48	2500	330.0	16.4	7.3	7.3	1.5	12.0	16.0	Q2

TAPE AND REEL BOX DIMENSIONS

*All dimensions are nominal

Device	Package Type	Package Drawing	Pins	SPQ	Length (mm)	Width (mm)	Height (mm)
CC430F5133IRGZR	VQFN	RGZ	48	2500	350.0	350.0	43.0
CC430F5135IRGZR	VQFN	RGZ	48	2500	350.0	350.0	43.0
CC430F5137IRGZR	VQFN	RGZ	48	2500	350.0	350.0	43.0

TUBE

*All dimensions are nominal

Device	Package Name	Package Type	Pins	SPQ	L (mm)	W (mm)	T (μm)	B (mm)
CC430F5133IRGZ	RGZ	VQFN	48	52	381	8.92	2286	0
CC430F5133IRGZ.Z	RGZ	VQFN	48	52	381	8.92	2286	0
CC430F5135IRGZ	RGZ	VQFN	48	52	381	8.92	2286	0
CC430F5135IRGZ.Z	RGZ	VQFN	48	52	381	8.92	2286	0
CC430F5137IRGZ	RGZ	VQFN	48	52	381	8.92	2286	0
CC430F5137IRGZ.Z	RGZ	VQFN	48	52	381	8.92	2286	0

GENERIC PACKAGE VIEW

RGC 64

VQFN - 1 mm max height

9 x 9, 0.5 mm pitch

PLASTIC QUAD FLATPACK - NO LEAD

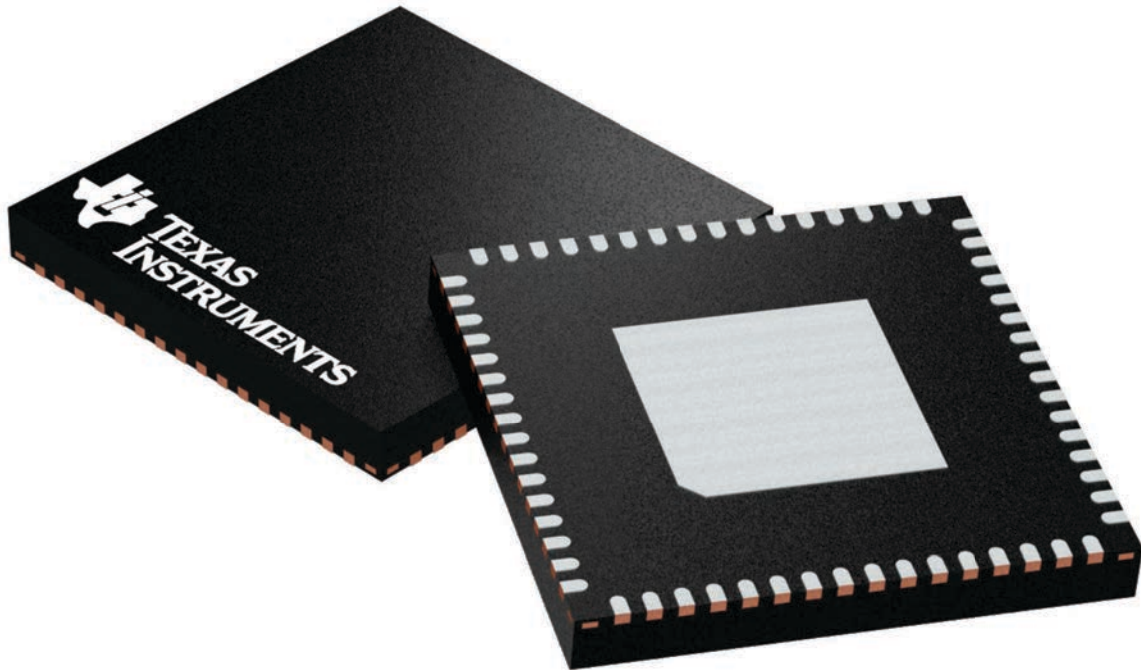

Images above are just a representation of the package family, actual package may vary.
Refer to the product data sheet for package details.

4224597/A

RGC0064B

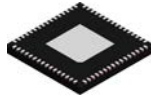

PACKAGE OUTLINE

VQFN - 1 mm max height

PLASTIC QUAD FLATPACK - NO LEAD

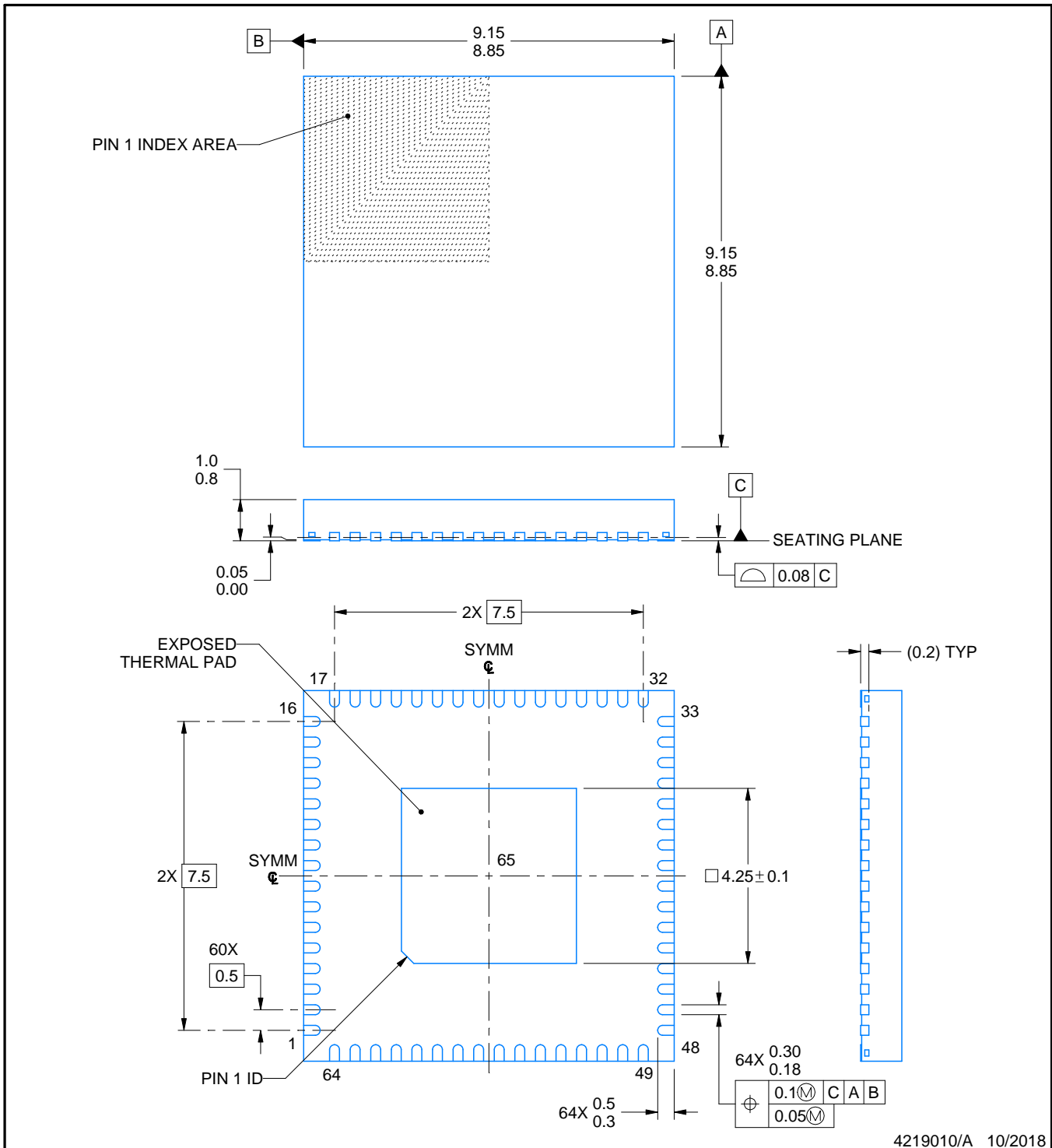

NOTES:

1. All linear dimensions are in millimeters. Any dimensions in parenthesis are for reference only. Dimensioning and tolerancing per ASME Y14.5M.
2. This drawing is subject to change without notice.
3. The package thermal pad must be soldered to the printed circuit board for thermal and mechanical performance.

EXAMPLE BOARD LAYOUT

RGC0064B

VQFN - 1 mm max height

PLASTIC QUAD FLATPACK - NO LEAD

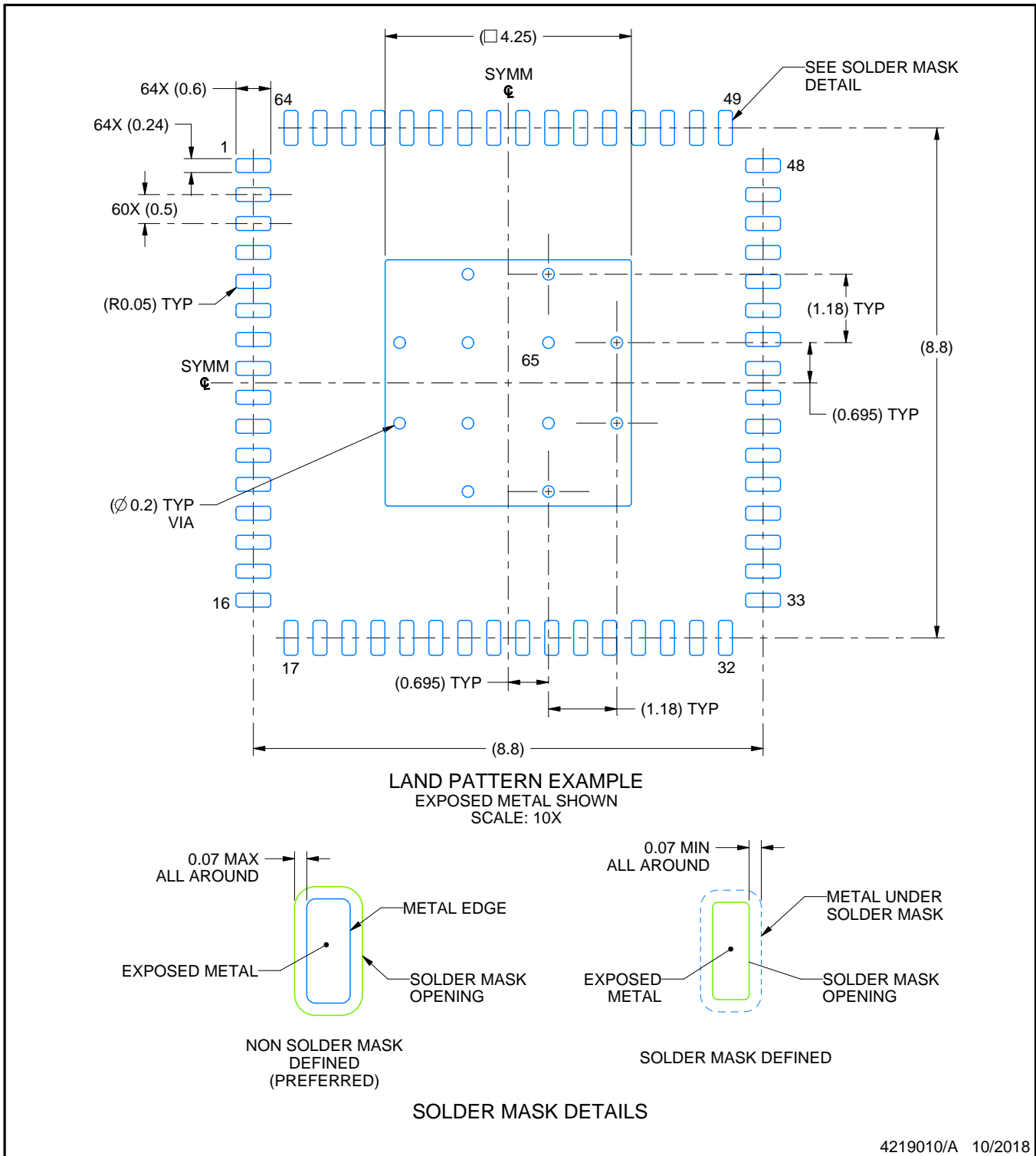

4219010/A 10/2018

NOTES: (continued)

4. This package is designed to be soldered to a thermal pad on the board. For more information, see Texas Instruments literature number SLUA271 (www.ti.com/lit/sluea271).
5. Vias are optional depending on application, refer to device data sheet. If any vias are implemented, refer to their locations shown on this view. It is recommended that vias under paste be filled, plugged or tented.

EXAMPLE STENCIL DESIGN

RGC0064B

VQFN - 1 mm max height

PLASTIC QUAD FLATPACK - NO LEAD

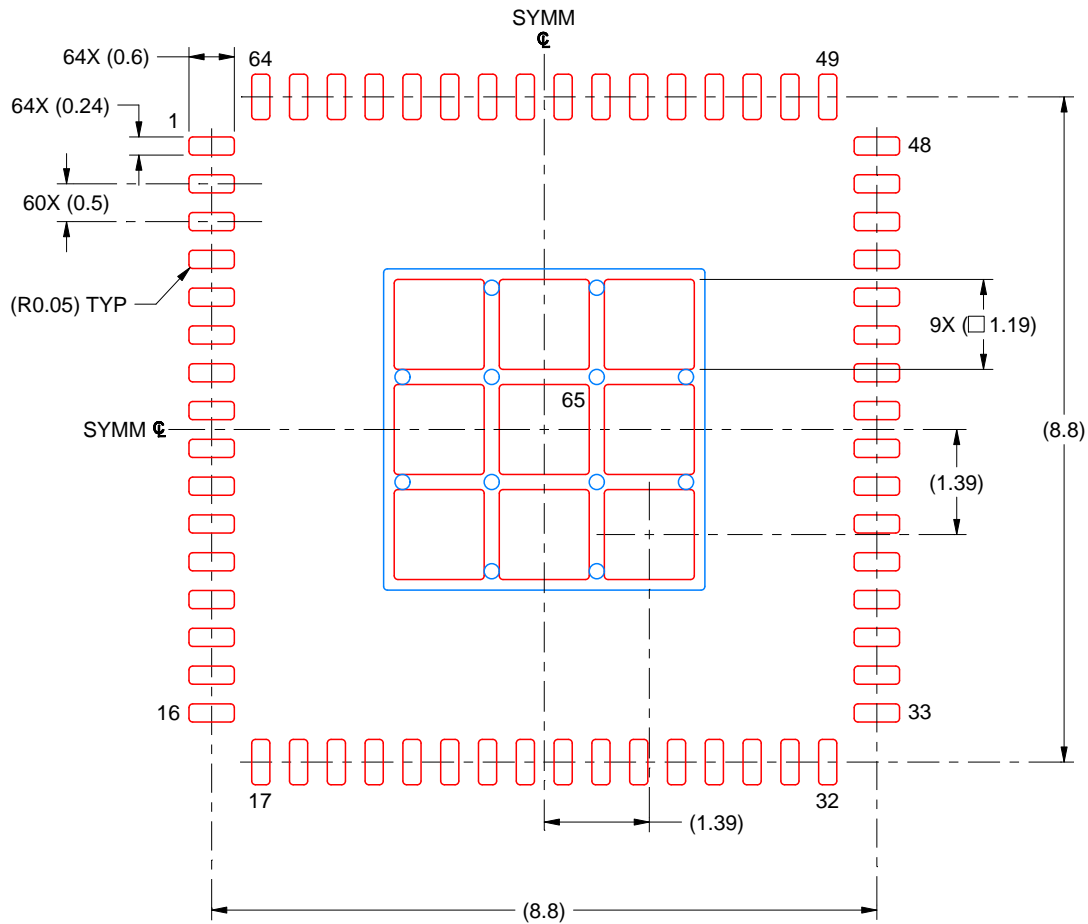

SOLDER PASTE EXAMPLE
 BASED ON 0.125 MM THICK STENCIL
 SCALE: 10X

EXPOSED PAD 65
 71% PRINTED SOLDER COVERAGE BY AREA UNDER PACKAGE

4219010/A 10/2018

NOTES: (continued)

6. Laser cutting apertures with trapezoidal walls and rounded corners may offer better paste release. IPC-7525 may have alternate design recommendations.

GENERIC PACKAGE VIEW

RGZ 48

VQFN - 1 mm max height

7 x 7, 0.5 mm pitch

PLASTIC QUADFLAT PACK- NO LEAD

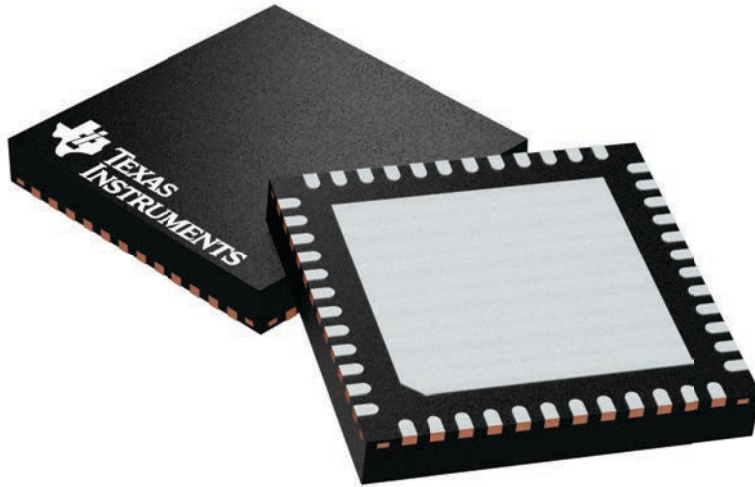

Images above are just a representation of the package family, actual package may vary.
Refer to the product data sheet for package details.

4224671/A

RGZ0048B

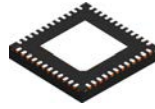

PACKAGE OUTLINE

VQFN - 1 mm max height

PLASTIC QUAD FLATPACK - NO LEAD

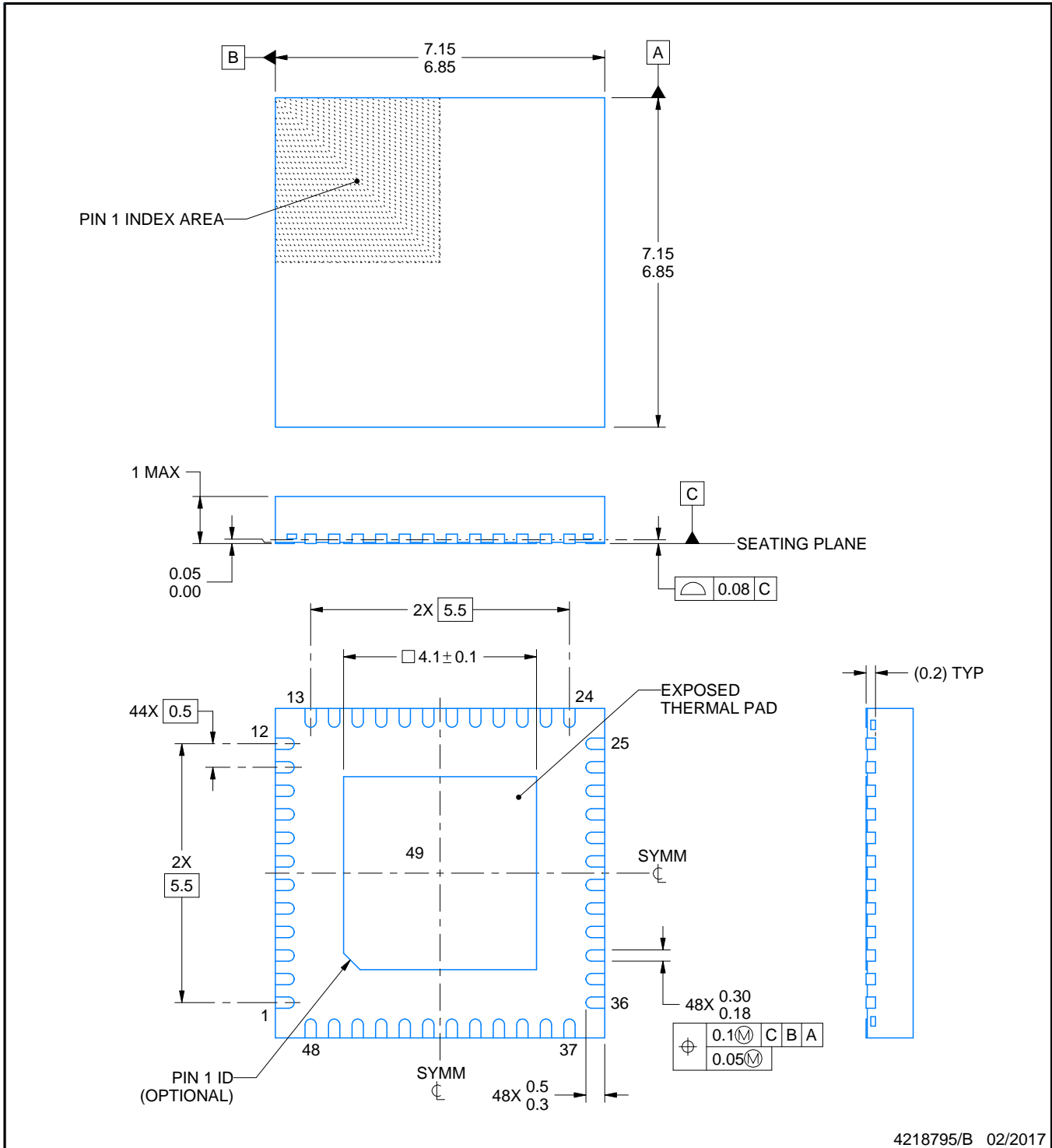

4218795/B 02/2017

NOTES:

1. All linear dimensions are in millimeters. Any dimensions in parenthesis are for reference only. Dimensioning and tolerancing per ASME Y14.5M.
2. This drawing is subject to change without notice.
3. The package thermal pad must be soldered to the printed circuit board for thermal and mechanical performance.

EXAMPLE BOARD LAYOUT

RGZ0048B

VQFN - 1 mm max height

PLASTIC QUAD FLATPACK - NO LEAD

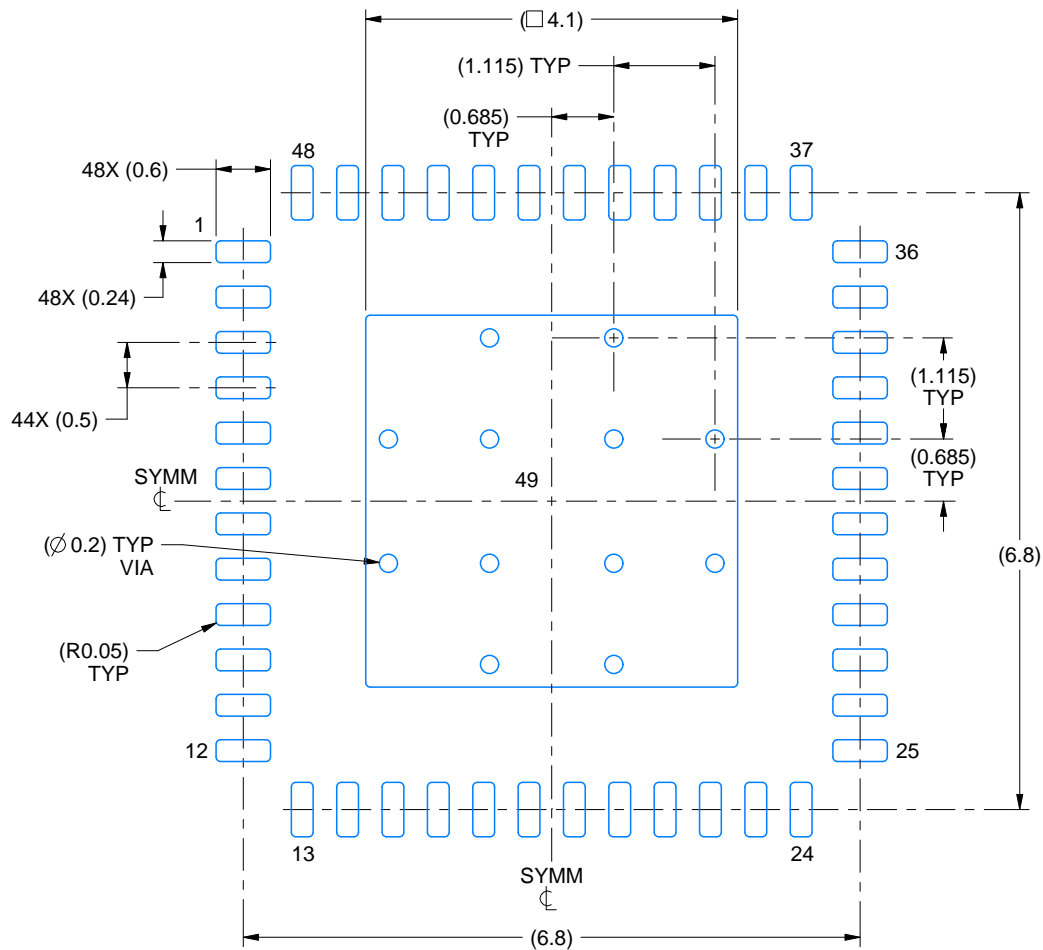

LAND PATTERN EXAMPLE
EXPOSED METAL SHOWN
SCALE:12X

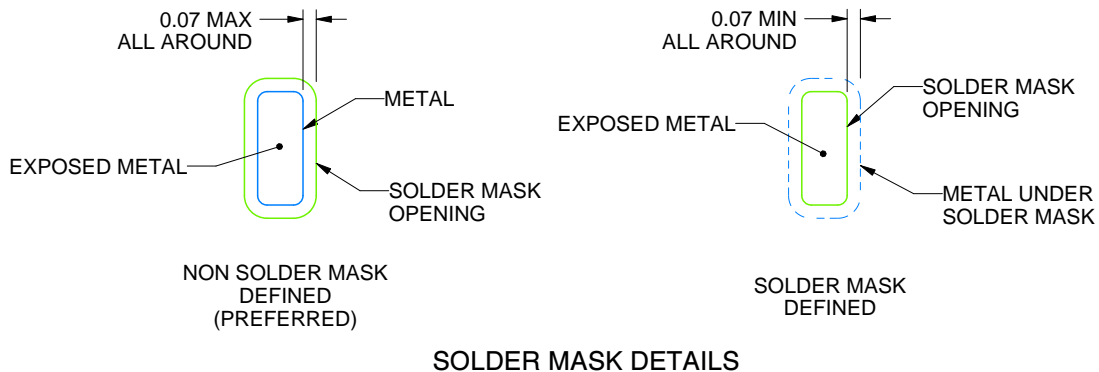

SOLDER MASK DETAILS

4218795/B 02/2017

NOTES: (continued)

4. This package is designed to be soldered to a thermal pad on the board. For more information, see Texas Instruments literature number SLUA271 (www.ti.com/lit/sluea271).
5. Vias are optional depending on application, refer to device data sheet. If any vias are implemented, refer to their locations shown on this view. It is recommended that vias under paste be filled, plugged or tented.

EXAMPLE STENCIL DESIGN

RGZ0048B

VQFN - 1 mm max height

PLASTIC QUAD FLATPACK - NO LEAD

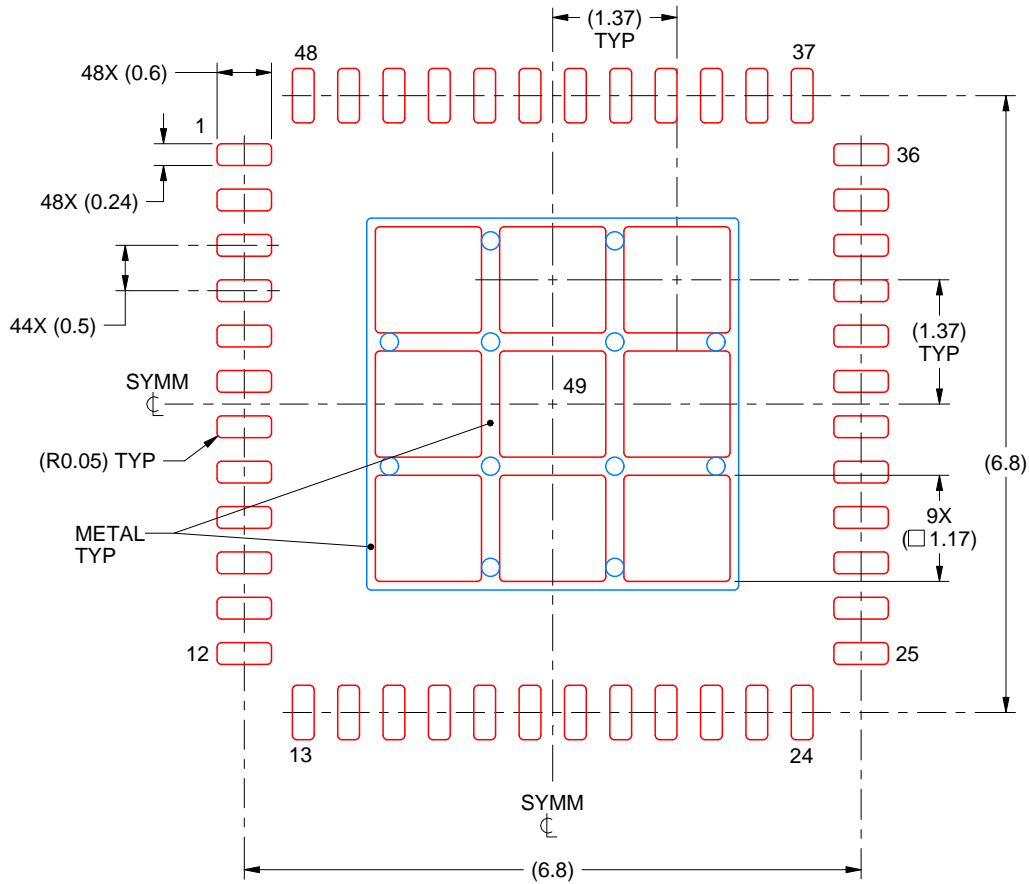

SOLDER PASTE EXAMPLE
 BASED ON 0.125 mm THICK STENCIL

EXPOSED PAD 49
 73% PRINTED SOLDER COVERAGE BY AREA UNDER PACKAGE
 SCALE:12X

4218795/B 02/2017

NOTES: (continued)

6. Laser cutting apertures with trapezoidal walls and rounded corners may offer better paste release. IPC-7525 may have alternate design recommendations.

重要通知和免责声明

TI“按原样”提供技术和可靠性数据（包括数据表）、设计资源（包括参考设计）、应用或其他设计建议、网络工具、安全信息和其他资源，不保证没有瑕疵且不做任何明示或暗示的担保，包括但不限于对适销性、某特定用途方面的适用性或不侵犯任何第三方知识产权的暗示担保。

这些资源可供使用 TI 产品进行设计的熟练开发人员使用。您将自行承担以下全部责任：(1) 针对您的应用选择合适的 TI 产品，(2) 设计、验证并测试您的应用，(3) 确保您的应用满足相应标准以及任何其他功能安全、信息安全、监管或其他要求。

这些资源如有变更，恕不另行通知。TI 授权您仅可将这些资源用于研发本资源所述的 TI 产品的相关应用。严禁以其他方式对这些资源进行复制或展示。您无权使用任何其他 TI 知识产权或任何第三方知识产权。您应全额赔偿因在这些资源的使用中对 TI 及其代表造成的任何索赔、损害、成本、损失和债务，TI 对此概不负责。

TI 提供的产品受 [TI 的销售条款](#) 或 [ti.com](#) 上其他适用条款/TI 产品随附的其他适用条款的约束。TI 提供这些资源并不会扩展或以其他方式更改 TI 针对 TI 产品发布的适用的担保或担保免责声明。

TI 反对并拒绝您可能提出的任何其他或不同的条款。

邮寄地址：Texas Instruments, Post Office Box 655303, Dallas, Texas 75265
版权所有 © 2025，德州仪器 (TI) 公司