

## bq50002A 适用于 WPC v1.2 A11 发送器的 低成本 5V 无线电源发送器模拟前端

### 1 特性

- 符合无线充电联盟 (WPC) v1.2 A11 低功耗发送器规范的 5V 发送器模拟前端 (AFE)
- 专为与 bq500511A WPC 控制器搭配使用而设计
  - 注：如果需要进行外来物体检测，则 bq50002A 与 bq500511 器件不兼容。
- 适用于 WPC 和 5V 专用无线电源发送器
- 支持 5W 的接收器输出功率
- 在无线电源发送器中集成了所需的全部模拟功能
  - 金属氧化物半导体场效应晶体管 (MOSFET) 驱动器和同步 N 沟道功率场效应晶体管 (FET)
  - 精确的电流感测
  - 变频振荡器
  - 高效稳压器
  - 用于对接收器信号进行解码的高灵敏度解调器
- 双芯片解决方案实现了效率超过 75% 的高效发送器设计
- 超低待机功耗，即使在数字 Ping 过程中也可实现 (< 30mW)
- 动态电源限制 (DPL)<sup>™</sup>通过功率受限的输入源实现正常运行
- 系统发光二极管 (LED) 指示充电状态和故障状态
- 精准的外来物体检测 (FOD) 方法

### 2 应用

- 适用于智能手机和可穿戴应用且符合 WPC 标准的无线发送器
- 专用无线充电器和发射器
- 医疗和可穿戴应用

### 3 说明

bq50002A 器件是一款高度集成的无线电源发送器模拟前端 (AFE)，其中包含实现符合无线充电联盟 (WPC) 标准的 5V 发送器所需的全部模拟组件。bq50002A 器件将全桥电源驱动器与 MOSFET、变频振荡器、双通道通信解调器、线性稳压器以及保护电路相集成。bq50002A 器件必须与数字控制器 bq500511A 一起搭配使用，以实现紧凑型双芯片无线电源发送器解决方案。bq500511A 可安全接合 Rx 器件、接收充电器件传输的通信数据包以及根据 WPC v1.2 规范管理功率传输。

该系统支持外来物体检测 (FOD)，具体方法是通过持续监视传输功率并将功率值与接收器报告的接收功率相比较。该功能可防止因在无线电源传输场中错误放置金属物体而产生功率损耗。为此，bq50002A 使用电流感测放大器对输入直流电流进行精确测量。如果在功率传输过程中出现任何异常情况，bq500511A 会对其进行处理并提供指示输出。综合状态和故障监视特性可实现一个经 WPC 认证的低成本、稳健耐用的无线电源系统设计。

bq50002A 采用 5.00mm × 5.00mm 32 引脚散热增强型四方扁平无引线 (QFN) 封装。

#### 器件信息 (1)

部件号	封装	封装尺寸 (标称值)
bq50002A	QFN (32)	5.00mm x 5.00mm

(1) 要了解所有可用封装，请见数据表末尾的可订购产品附录。

简化电路原理图

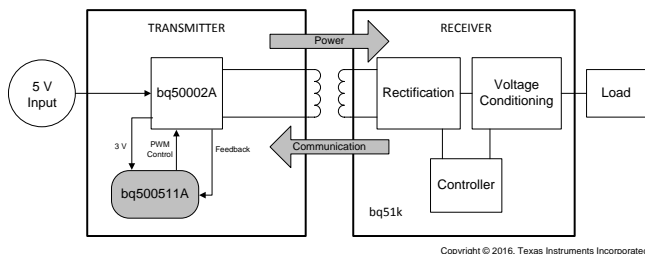

效率与功率间的关系

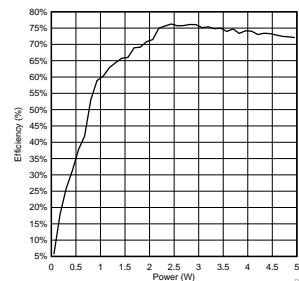

## 目录

<b>1</b>	特性 .....	<b>1</b>	7.4	Device Functional Modes.....	<b>12</b>
<b>2</b>	应用 .....	<b>1</b>	<b>8</b>	<b>Application and Implementation</b> .....	<b>14</b>
<b>3</b>	说明 .....	<b>1</b>	8.1	Application Information.....	<b>14</b>
<b>4</b>	修订历史记录 .....	<b>2</b>	8.2	Typical Application .....	<b>15</b>
<b>5</b>	<b>Pin Configuration and Functions</b> .....	<b>3</b>	<b>9</b>	<b>Power Supply Recommendations</b> .....	<b>19</b>
<b>6</b>	<b>Specifications</b> .....	<b>5</b>	<b>10</b>	<b>Layout</b> .....	<b>19</b>
6.1	Absolute Maximum Ratings .....	<b>5</b>	10.1	Layout Guidelines .....	<b>19</b>
6.2	ESD Ratings .....	<b>5</b>	10.2	Layout Examples.....	<b>20</b>
6.3	Recommended Operating Conditions.....	<b>5</b>	<b>11</b>	器件和文档支持 .....	<b>23</b>
6.4	Thermal Information .....	<b>6</b>	11.1	文档支持 .....	<b>23</b>
6.5	Electrical Characteristics.....	<b>6</b>	11.2	接收文档更新通知 .....	<b>23</b>
6.6	Typical Characteristics.....	<b>7</b>	11.3	社区资源.....	<b>23</b>
<b>7</b>	<b>Detailed Description</b> .....	<b>8</b>	11.4	商标.....	<b>23</b>
7.1	Overview .....	<b>8</b>	11.5	静电放电警告.....	<b>23</b>
7.2	Functional Block Diagram .....	<b>8</b>	11.6	Glossary .....	<b>23</b>
7.3	Feature Description.....	<b>9</b>	<b>12</b>	机械、封装和可订购信息.....	<b>23</b>

## 4 修订历史记录

日期	修订版本	注释
2016 年 8 月	A	最初发布。

## 5 Pin Configuration and Functions

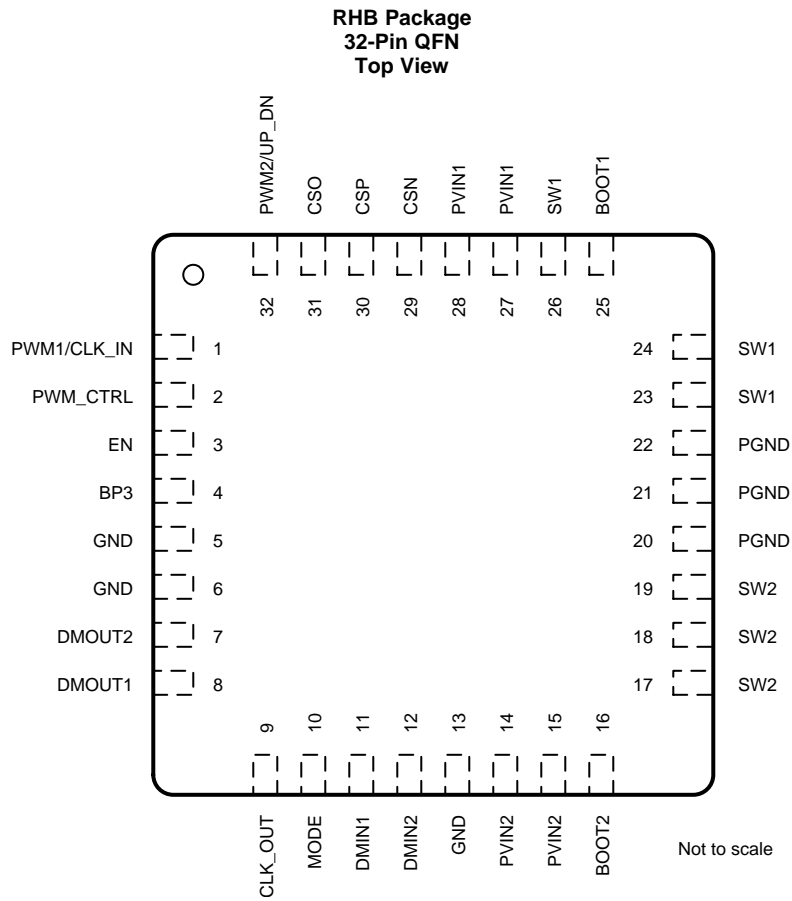

### Pin Functions

PIN		I/O	DESCRIPTION
NAME	NO.		
BOOT1	25	I/O	Positive supply rail for the high-side gate driver. Connect a 0.1- $\mu$ F ceramic capacitor between the BOOT1 and SW1 pins.
BOOT2	16	I/O	Positive supply rail for the high-side gate driver. Connect a 0.1- $\mu$ F ceramic capacitor between the BOOT2 and SW2 pins.
BP3	4	O	LDO output. Tie with 2.2- $\mu$ F capacitor to GND. For use by bq500511A only.
CLK_OUT	9	O	Internal oscillator clock out signal.
CSN	29	I	Current sense amplifier negative input.
CSO	31	O	Current sense amplifier output. For use by bq500511A only.
CSP	30	I	Current sense amplifier positive input. Connect current sense resistor as close as possible to this pin. This also serves as the quiet node for power supply input.
DMIN1	11	I	Modulated signal from coil for DEMOD CHAN1.
DMIN2	12	I	Modulated signal from coil for DEMOD CHAN2.
DMOUT1	8	O	Demodulated 2-kHz signal from CHAN1. For use by bq500511A only.
DMOUT2	7	O	Demodulated 2-kHz signal from CHAN2. For use by bq500511A only.
EN	3	I	Enable pin with a weak internal pull-down. Float or pull below 1.5 V to disable gate driver, demodulation and current sense. Pull above 2.2 V to enable gate driver. Used by bq500511A to enter and leave standby mode for the transmitter.
GND	5	–	Signal ground for the ground-referenced logic. All signal level circuits should be referenced to this pin unless otherwise noted.
GND	6	–	Signal ground for the ground-referenced logic. All signal level circuits should be referenced to this pin unless otherwise noted.
GND	13	–	Signal ground for the ground-referenced logic. All signal level circuits should be referenced to this pin unless otherwise noted.
MODE	10	I	MODE pin with a weak internal pull-down. Float, or pull below 1.5 V to enable frequency control of the internally generated PWM signal. Pull above 2.2 V to enable pulse width control of the internally generated PWM signal. Used by bq500511A to select the control method for power control
PGND	20	–	Power ground for the ground-referenced power stage. Connect to GND.
PGND	21	–	Power ground for the ground-referenced power stage. Connect to GND.
PGND	22	–	Power ground for the ground-referenced power stage. Connect to GND.
PVIN1	27	I	DC input voltage for half-bridge MOSFET. Bypass with 22- $\mu$ F ceramic capacitor to GND.
PVIN1	28	I	DC input voltage for half-bridge MOSFET. Bypass with 22- $\mu$ F ceramic capacitor to GND.
PVIN2	14	I	DC input voltage for half-bridge MOSFET. Bypass with 22- $\mu$ F ceramic capacitor to GND.
PVIN2	15	I	DC input voltage for half-bridge MOSFET. Bypass with 22- $\mu$ F ceramic capacitor to GND.
PWM_CTRL	2	I	PWM_CTRL pin with a weak internal pull-down. Controlled by bq500511A (SLUSCN3) for system power delivery control.
PWM1/CLK_IN	1	I	PWM1/CLK_IN pin with a weak internal pull-down. Controlled by bq500511A (SLUSCN3) for system power delivery control.
PWM2/UP_DN	32	I	PWM2/UP_DN pin with a weak internal pull-down. Controlled by bq500511A (SLUSCN3) for system power delivery control.
SW1	23	O	Switch node of the half-bridge MOSFETs. Connect to TX coil.
SW1	24	O	Switch node of the half-bridge MOSFETs. Connect to TX coil.
SW1	26	O	Switch node of the half-bridge MOSFETs. Connect to TX coil.
SW2	17	O	Switch node of the half-bridge MOSFETs. Connect to resonant capacitor.
SW2	18	O	Switch node of the half-bridge MOSFETs. Connect to resonant capacitor.
SW2	19	O	Switch node of the half-bridge MOSFETs. Connect to resonant capacitor.

## 6 Specifications

### 6.1 Absolute Maximum Ratings

over operating free-air temperature range (unless otherwise noted) <sup>(1)</sup>

	MIN	MAX	UNIT
PVIN1, PVIN2	−0.3	7	V
BOOT1 <sup>(2)</sup>	−0.3	14	V
VBOOT1 – VSW1	−0.3	7	V
BOOT2 <sup>(2)</sup>	−0.3	14	V
VBOOT2 – VSW2	−0.3	7	V
PWM1, PWM2, EN, CLK_OUT, MODE, PWM_CTRL	−0.3	3.6	V
DMIN1	−5	7	V
DMIN2	−0.3	7	V
CSN, CSP	−0.3	7	V
CSN to CSP	−0.5	0.5	V
Operating junction temperature, T <sub>J</sub>	−40	125	°C
Storage temperature, T <sub>stg</sub>	−55	150	°C

- (1) Stresses beyond those listed under *Absolute Maximum Ratings* may cause permanent damage to the device. These are stress ratings only, which do not imply functional operation of the device at these or any other conditions beyond those indicated under *Recommended Operating Conditions*. Exposure to absolute-maximum-rated conditions for extended periods may affect device reliability.
- (2) In normal use, BOOT1, BOOT2 voltage internally regulated.

### 6.2 ESD Ratings

		VALUE	UNIT
V <sub>(ESD)</sub> Electrostatic discharge	Human-body model (HBM), per ANSI/ESDA/JEDEC JS-001 <sup>(1)</sup>	±1000	V
	Charged-device model (CDM), per JEDEC specification JESD22-C101 <sup>(2)</sup>	±500	V

- (1) JEDEC document JEP155 states that 500-V HBM allows safe manufacturing with a standard ESD control process.
- (2) JEDEC document JEP157 states that 250-V CDM allows safe manufacturing with a standard ESD control process.

### 6.3 Recommended Operating Conditions

over operating free-air temperature range (unless otherwise noted)

		MIN	NOM	MAX	UNIT
	PVIN1, PVIN2	4.5	5	5.5	V
	PWM1, PWM2, EN, CLK_OUT, MODE, PWM_CTRL	0	3	3.3	V
	DMIN1	−0.3		5	V
	DMIN2	−0.3		5	V
C <sub>BP3</sub>	BP3 ceramic capacitor		2.2		μF
C <sub>PVIN1</sub> , C <sub>PVIN2</sub>	PVIN1, PVIN2 ceramic capacitor		0.1		μF
C <sub>PVIN1</sub> , C <sub>PVIN2</sub>	PVIN1, PVIN2 electrolytic capacitor		22		μF
C <sub>BOOT1</sub> , C <sub>BOOT2</sub>	SW1-BOOT1, SW2-BOOT2 capacitor		0.1		μF

## 6.4 Thermal Information

THERMAL METRIC <sup>(1)</sup>		bq50002A	
		RHB (QFN)	UNIT
		32 PINS	
$R_{\theta JA}$	Junction-to-ambient thermal resistance	40.6	°C/W
$R_{\theta JC(top)}$	Junction-to-case (top) thermal resistance	32.1	°C/W
$R_{\theta JB}$	Junction-to-board thermal resistance	13.1	°C/W
$\psi_{JT}$	Junction-to-top characterization parameter	0.8	°C/W
$\psi_{JB}$	Junction-to-board characterization parameter	13	°C/W
$R_{\theta JC(bot)}$	Junction-to-case (bottom) thermal resistance	5.7	°C/W

(1) For more information about traditional and new thermal metrics, see the [Semiconductor and IC Package Thermal Metrics](#) application report.

## 6.5 Electrical Characteristics

–40°C ≤ T<sub>J</sub> ≤ +125°C, V<sub>PVIN1</sub> = 5 V, V<sub>PVIN2</sub> = 5 V (unless otherwise noted)

PARAMETER	TEST CONDITIONS	MIN	TYP	MAX	UNIT
<b>INPUT VOLTAGE (VIN)</b>					
UVLO rising threshold	V <sub>IN</sub> rising	3.75	3.9	4.2	V
UVLO falling threshold	V <sub>IN</sub> falling	3.6	3.85	4.08	V
<b>REGULATOR VOLTAGE (BP3)</b>					
BP3 output voltage	I <sub>BP3</sub> = –5 mA, V <sub>PVIN1</sub> = V <sub>PVIN2</sub> = 5 V	2.9	3	3.1	V
BP3 output voltage	I <sub>BP3</sub> = –10 mA, V <sub>PVIN1</sub> = V <sub>PVIN2</sub> = 5 V	2.9	3	3.1	V
BP3 load current max	V <sub>BP3</sub> = 2.7 V, V <sub>PVIN1</sub> = V <sub>PVIN2</sub> = 5 V	7.7	14	21	mA
<b>CURRENT SENSE AMPLIFIER (CSP, CSN)</b>					
Current sense amplifier gain	0°C < T <sub>J</sub> < 85°C		50		V/V
Input current (CSP)	V <sub>CSP</sub> = 5 V, V <sub>PVIN1</sub> = V <sub>PVIN2</sub> = 5 V		1.5		mA
Input current (CSN)	V <sub>CSN</sub> = 5 V, V <sub>PVIN1</sub> = V <sub>PVIN2</sub> = 5 V	8.5	10	11.3	μA
<b>EN</b>					
High-level input voltage	Input rising	1.7	1.8	1.9	V
Low-level input voltage	Input falling	0.8	1	1.1	V
EN pull-down resistance	EN = 3 V	40	50	60	kΩ
<b>PWM_CTRL</b>					
High-level input voltage	Input rising	1.4	1.6	1.8	V
Low-level input voltage	Input falling	0.9	1	1.1	V
PWM_CTRL pull-down resistance	PWM_CTRL = 3 V	40	50	60	kΩ

## Electrical Characteristics (continued)

 $-40^{\circ}\text{C} \leq T_J \leq +125^{\circ}\text{C}$ ,  $V_{PVIN1} = 5\text{ V}$ ,  $V_{PVIN2} = 5\text{ V}$  (unless otherwise noted)

PARAMETER	TEST CONDITIONS	MIN	TYP	MAX	UNIT
<b>PWM1</b>					
High-level input voltage	Input rising	1.6	1.8	1.9	V
Low-level input voltage	Input falling	0.9	1	1.1	V
PWM1 pull-down resistance	PWM1 = 3 V	40	50	60	k $\Omega$
<b>PWM2</b>					
High-level input voltage	Input rising	1.6	1.7	1.8	V
Low-level input voltage	Input falling	1	1.1	1.2	V
PWM2 pull-down resistance	PWM2 = 3 V	40	50	60	k $\Omega$
<b>MODE</b>					
High-level input voltage	Input rising	1.7	1.8	1.9	V
Low-level input voltage	Input falling	0.9	1	1.1	V
MODE pull-down resistance	MODE = 3 V	40	50	60	k $\Omega$
<b>BOOTSTRAP DIODE (BOOT1 AND BOOT2)</b>					
Regulation voltage (BOOT1)	$V_{PVIN1} = V_{PVIN2} = 5\text{ V}$ , $I_{BOOT} = 0\text{ mA}$	4.2	4.4	4.7	V
Regulation voltage (BOOT2)	$V_{PVIN1} = V_{PVIN2} = 5\text{ V}$ , $I_{BOOT} = 0\text{ mA}$	4.9	5	5.1	V
UVLO (BOOT1)	$V_{PVIN1} = V_{PVIN2} = 5\text{ V}$	1.8	2.3	2.7	V
UVLO (BOOT2)	$V_{PVIN1} = V_{PVIN2} = 5\text{ V}$	1.8	2.2	2.6	V
<b>MOSFETS (SW1 AND SW2)</b>					
SW1 high-side $R_{DS(on)}$	$V_{PVIN1} = V_{PVIN2} = 5\text{ V}$	59	76	107	m $\Omega$
SW1 low-side $R_{DS(on)}$	$V_{PVIN1} = V_{PVIN2} = 5\text{ V}$	48	61	86	m $\Omega$
SW2 high-side $R_{DS(on)}$	$V_{PVIN1} = V_{PVIN2} = 5\text{ V}$	42	49	64	m $\Omega$
SW2 low-side $R_{DS(on)}$	$V_{PVIN1} = V_{PVIN2} = 5\text{ V}$ , $I_{SW} = 500\text{ mA}$	39	46	58	m $\Omega$

## 6.6 Typical Characteristics

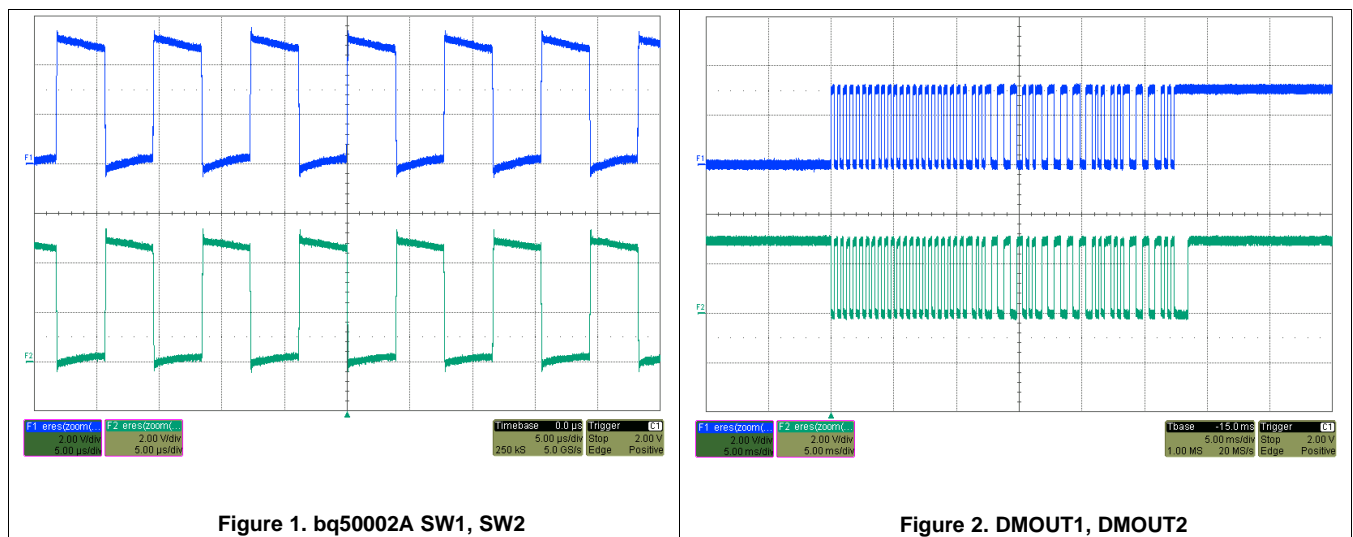

## 7 Detailed Description

### 7.1 Overview

The principle of wireless power transfer is simply an open-cored transformer consisting of transmitter and receiver coils. The transmitter coil and electronics are typically built into a charger pad and the receiver coil and electronics are typically built into a portable device, such as a smart phone. When the receiver coil is positioned on the transmitter coil, magnetic coupling occurs when the transmitter coil is driven. The flux is coupled into the secondary coil, which induces a voltage and current flows. The secondary voltage is rectified, and power can be transferred effectively to a load, wirelessly. Power transfer can be managed through various closed loop control schemes.

After power is applied and the transmitter device comes out of reset, the process of detecting and powering a receiver automatically begins. The bq500511A sends a ping to detect the presence of a receiver on the pad. After a receiver is detected, the bq500511A attempts to establish communication and begin power transfer. The bq500511A is designed to operate with the bq50002A Wireless Power Transmitter Analog Front End to control a full-bridge power stage to drive the primary coil. Through a simple interface the bq500511A instructs the bq50002A how much to increase or decrease power. The full bridge power stage allows for higher power delivery for a given supply voltage.

### 7.2 Functional Block Diagram

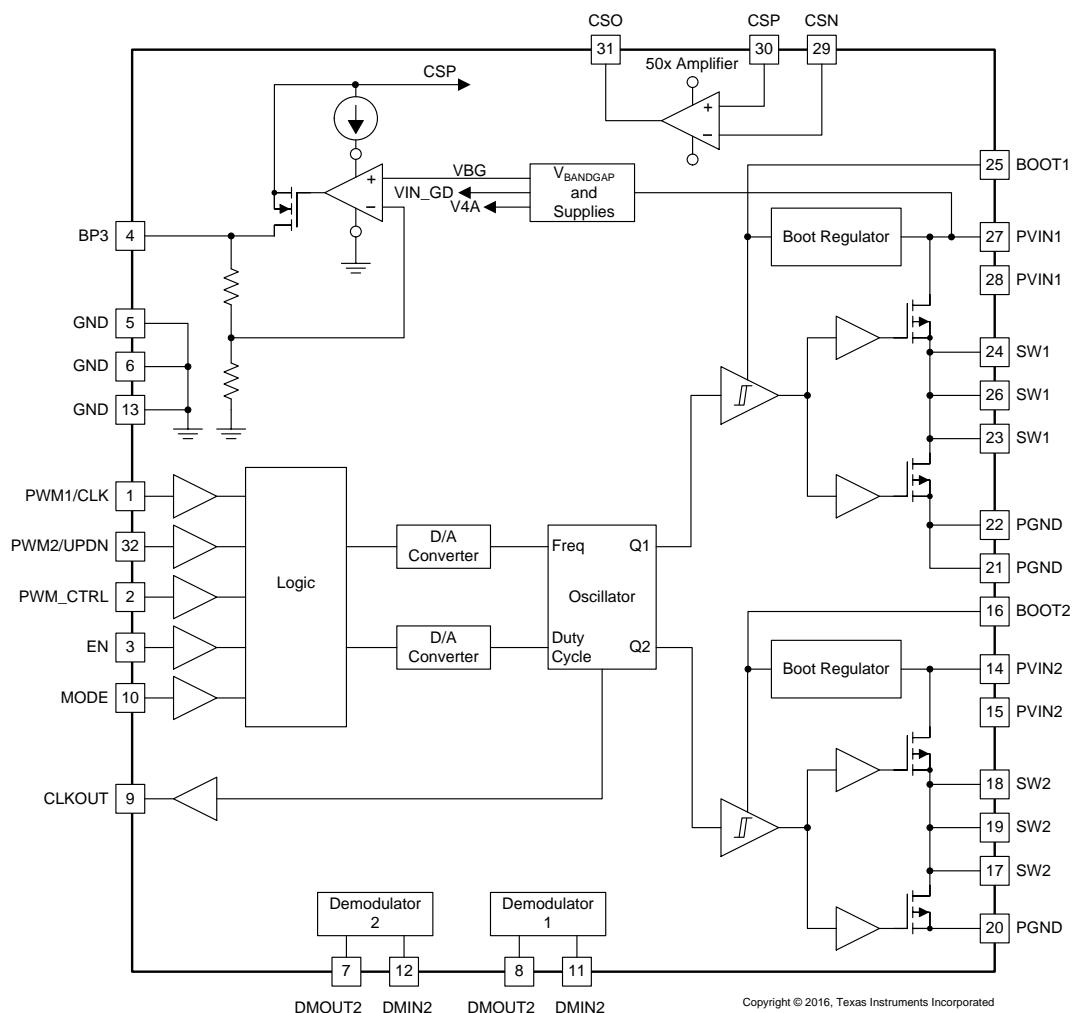



### 7.3 Feature Description

#### 7.3.1 Demodulator

The embedded demodulator outputs at least one valid bit stream under all modulation conditions that can be used by the accompanied bq500511A controller in order to comply with WPC specification.

More specifically, the WPC worst case condition is defined as the transmitter operating at the minimum modulation level, and the receiver coil is measured by certain x, y and z axis distance to the center of the transmitter coil.

Analog demodulation channel function diagram:

- The diagram below from the WPC spec document explains the concept of Minimum Modulation. The peak-to-peak amplitude difference in TX coil waveform between HI and LO states is 400 mV. With 20-V<sub>pp</sub> carrier waveform, and 400-mV<sub>pp</sub> modulation, with a typical divider it translates to 1 V<sub>pp</sub> ±20 mV<sub>pp</sub> at the input of the demodulator channel.
- The difference of the amplitude of the primary cell voltage in the HI and LO state is at least 200 mV.

During a transition the primary cell current and primary cell voltages are undefined. See [Figure 3](#).

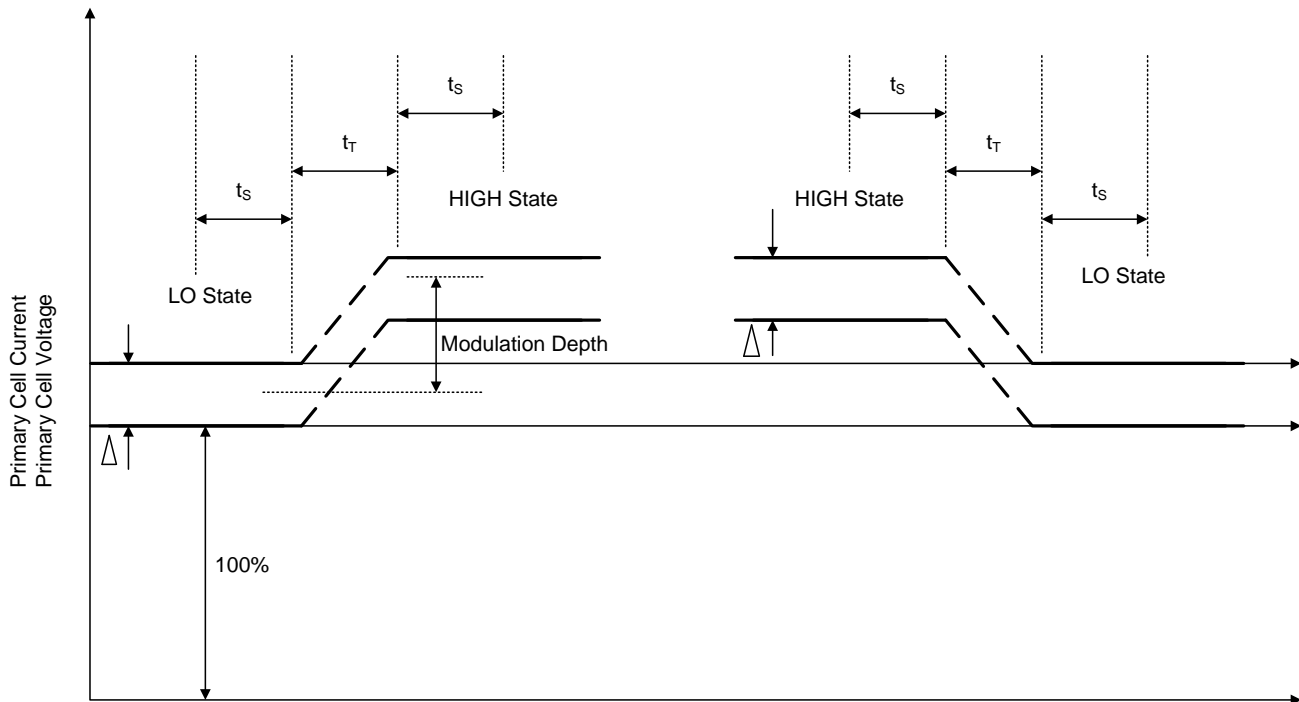

Figure 3. Amplitude Modulation of the Power Signal

## Feature Description (continued)

### 7.3.2 PWM Control

#### 7.3.2.1 PWM\_CTRL Input

The bq50002A device operates in two modes:

Direct PWM Control Mode and Self Switching. The mode of operation is set by the state of PWM\_CTRL input when EN=HIGH. This is intended for control by bq500511A.

#### 7.3.2.2 PWM1, PWM2

bq50002A passes external PWM inputs to drive gate drivers when the following conditions hold:

- EN pin is HIGH
- PWM\_CTRL pin is HIGH
- Typical Dead Time shall be better than 20 ns. Minimum PWM input pulse duration that changes SW output should be less than 50 ns.

#### 7.3.2.3 Self-Switching

bq50002A follows the commands from the controller to adjust the internal oscillator frequency up or down to adjust output power levels when the following conditions apply:

- PWM\_CTRL pin is LOW
- PWM1/CLK\_IN behaves as CLK\_IN pin. The CLK\_IN rising edge triggers frequency increase or decrease by one step based on the state of PWM2/UP\_DN pin.
- Self-switching starts at F=175 kHz when PWM\_CTRL state changes from HIGH to LOW. Operating frequency changes are based on the inputs of UP\_DN, CLK\_IN and MODE.
- The CLK\_OUT pin outputs 3.3V logic level with frequency equal in value to the current switching frequency. The rising edge of this signal coincides with the rising edge of the SW1 waveform. The duty factor of the signal on CLK\_OUT pin is 50%.
- bq50002A increases the frequency (reduces delivered power) if:
  - PWM\_CTRL pin is LOW
  - MODE pin is LOW
  - UP\_DN pin is LOW
  - CLK\_IN pin changes its state from LOW to HIGH (rising edge)
- bq50002A decreases the frequency (increases delivered power) if:
  - PWM\_CTRL pin is LOW
  - MODE pin is LOW
  - UP\_DN pin is HIGH
  - CLK\_IN pin changes its state from LOW to HIGH (rising edge)

## Feature Description (continued)

### 7.3.2.4 Duty Cycle Adjustment

bq50002A follows the commands from the controller to adjust the internal oscillator duty cycle up or down to adjust power output levels when the following conditions hold:

- The internal clock is set to the highest frequency tap, 205 kHz
- PWM\_CTRL pin is LOW
- MODE pin is HIGH
- bq50002A decreases the duty cycle (reduces delivered power) if:
  - The internal clock is set to the highest frequency tap, 205 kHz or at frequency at which MCU commands MODE = 1
  - PWM\_CTRL pin is LOW
  - MODE pin is HIGH
  - UP\_DN is LOW
  - CLK\_IN pin changes state from LOW to HIGH (rising edge)
  - bq50002A ignores CLK\_IN signals when minimum duty factor position of 10% is reached
- bq50002A increases the duty cycle (increases delivered power) if:
  - The internal clock is set to the highest frequency tap, 205 kHz at frequency at which MCU commands MODE = 1
  - PWM\_CTRL pin is LOW
  - MODE pin is HIGH
  - UP\_DN is HIGH
  - CLK\_IN pin changes state from LOW to HIGH (rising edge)
  - bq50002A ignores CLK\_IN signals when maximum duty factor position of 50% is reached. bq50002A will resume clock frequency adjustment mode only when the duty cycle adjustment has reached the 50% state and MODE=0.

### 7.3.3 Current Sense Amplifier

To support foreign object detection (FOD), the bq50002A senses the average input current to the device. The integrated current sense amplifier has voltage gain of 50. When paired with the bq500511A the offset in the bq50002A current sense amplifier is dynamically compensated, which allows accurate FOD performance.

### 7.3.4 Voltage Regulator

The bq50002A device has an integrated low-dropout (LDO) voltage regulator which supplies power to the companion bq500511A controller. The BP3 pin supplies a regulated 3-V voltage supply and should have a 2.2- $\mu$ F capacitor tied to GND.

## 7.4 Device Functional Modes

### 7.4.1 Power Transfer

Power transfer efficiency and robustness depends on coil coupling. Coupling depends on the distance between coils, alignment, coil dimensions, coil materials, number of turns, magnetic shielding, impedance matching, frequency. Most importantly, the receiver and transmitter coils must be aligned for best coupling and efficient power transfer. The smaller the space between the coils is, the better the coupling. Shielding is added as a backing to both the transmitter and receiver coils to direct the magnetic field to the coupled zone. Magnetic fields outside the coupled zone do not transfer power. Thus, shielding also serves to contain the fields to avoid coupling to other adjacent system components.

Regulation can be achieved by controlling any one of the coil coupling parameters. However, for WPC compatibility, the transmitter-side coils and capacitance are specified and the resonant frequency point is fixed. In the bq500511A or bq50002A system power transfer is regulated by changing the operating frequency between 110 kHz to 205 kHz. The higher the frequency, the further from resonance and the lower the power. Duty cycle remains constant at 50% throughout the power band and is reduced only once 205 kHz is reached.

#### 7.4.1.1 Dynamic Power Limiting™

Dynamic Power Limiting™ (DPL) allows operation from a 5-V supply with limited current capability (such as a USB port). When the input voltage is observed drooping, the output power is dynamically limited to reduce the load and provides margin relative to the supply's capability.

Anytime the DPL control loop is regulating the operating point of the transmitter, the LED will indicate that DPL is active. The LED color and flashing pattern are determined by the LED Table. If the receiver sends a Control Error Packet (CEP) with a negative value, (for example, to reduce power to the load), the bq500511A in DPL mode will return to normal operation and respond to this CEP through the standard WPC control loop behavior.

## Device Functional Modes (continued)

### 7.4.2 Communication

Communication within the WPC v1.2 specification is from the receiver to the transmitter. For example, in order to regulate the output of the transmitter, the receiver sends messages requesting the transmitter to increase or decrease power. The receiver communicates by modulating the rectifier voltage and using amplitude modulation (AM) sends packets of information to the transmitter. A packet is comprised of a preamble, a header, the actual message, and a checksum, as defined by the WPC standard.

The receiver sends a packet by modulating an impedance network. This AM signal reflects back as a change in the voltage amplitude on the transmitter coil. In the bq500511A or bq50002A system, the bq50002A performs the demodulation function and passes a digitized version of the message to the bq500511 where the message is decoded and processed. For example in response to a Control Error Packet, the bq500511A calculates the required change in output power and in turn controls the bq50002A through the CLK\_OUT, UP\_DOWN, and MODE pins to adjust the operating point and thus its output power.

The modulation impedance network on the receiver can either be resistive or capacitive. Figure 4 shows the resistive modulation approach, where a resistor is periodically added to the load, resulting in an amplitude change in the transmitter voltage. Figure 5 shows the corresponding capacitive modulation approach.

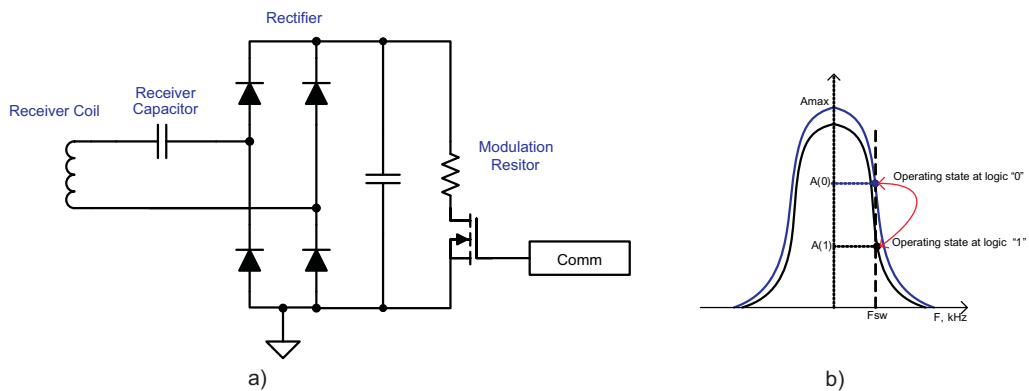

Figure 4. Receiver Resistive Modulation Circuit

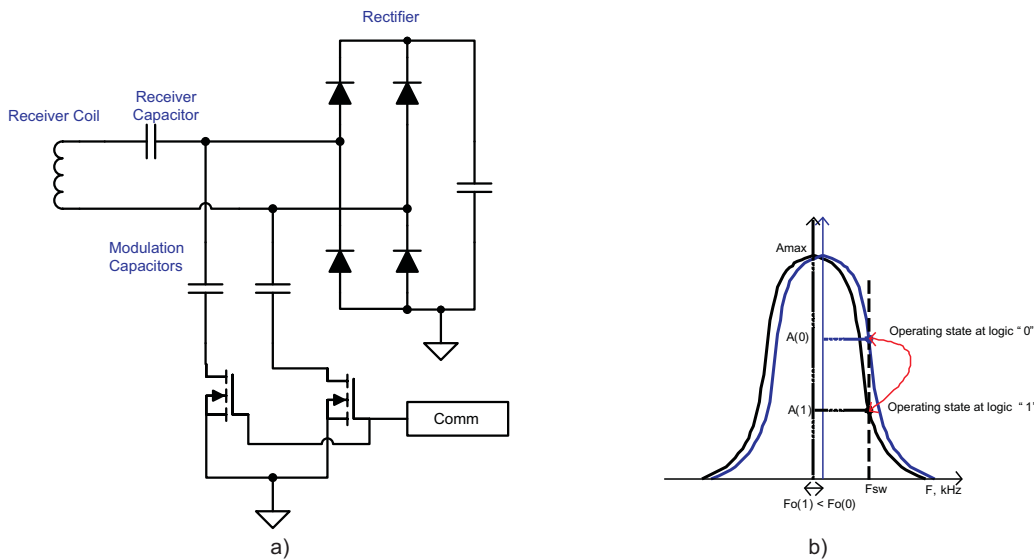

Figure 5. Receiver Capacitive Modulation Circuit

## 8 Application and Implementation

### NOTE

Information in the following applications sections is not part of the TI component specification, and TI does not warrant its accuracy or completeness. TI's customers are responsible for determining suitability of components for their purposes. Customers should validate and test their design implementation to confirm system functionality.

### 8.1 Application Information

The bq50002A device is a wireless power transmitter AFE designed for 5-W WPC compliant applications when paired with the bq500511A. The pair integrates all functions required to control wireless power transfer to a WPC v1.2 compliant receiver. Several tools are available for the design of the system. See the product folder on [www.ti.com](http://www.ti.com) for more details. The following sections highlight some of the system design considerations.

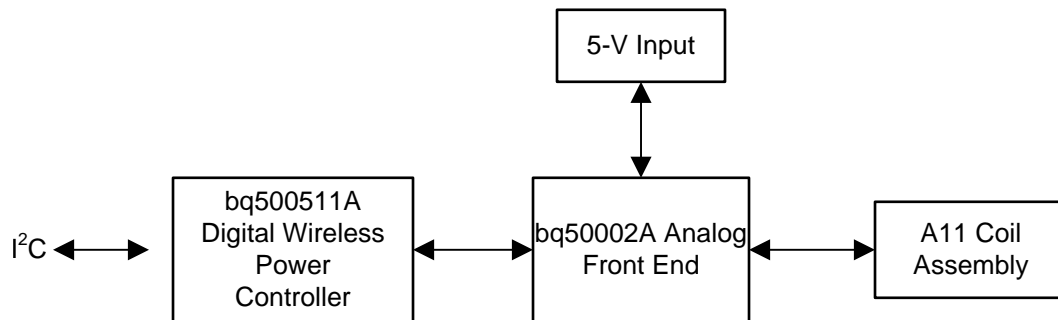

Copyright © 2016, Texas Instruments Incorporated

**Figure 6. System Block Diagram**

The I<sup>2</sup>C port is accessed by the FOD tuning tool and can provide a level of system monitoring and evaluation.

The SDA and SCL lines of the I<sup>2</sup>C bus must be pulled up (as shown in the ) if the I<sup>2</sup>C port is utilized. They may be left floating if no I<sup>2</sup>C function is required. The logic reference generated by the bq50002A Analog Front End is 3 V, so care should be taken to ensure that if the Master I<sup>2</sup>C device also has pull-up resistors to a higher reference, that the the 3-V reference to the bq500511A is not affected. Specifically, only one set of pull-up resistors should be populated, either on the I<sup>2</sup>C Master bus or on the bq500511A system board, but not both.

## 8.2 Typical Application

The bq50002A is a highly integrated analog front end device which, when paired with the bq500511A controller, requires a minimum of external components to implement a WPC V 1.2 Wireless Power Transmitter system.

As shown in the application schematic, external components are used to implement the following functions:

- Resonant Tank Circuit
- Demodulator Input Signal Conditioning
- Human Interface (LED and Buzzer)
- Current Sensing
- Voltage Sensing
- Temperature Sensing
- System Configuration
  - Foreign Objection Detection (FOD) Threshold and Calibration
  - LED Mode





## 8.2.1 Design Requirements

For this design example, use the parameter listed in [Table 1](#) as the input parameter.

**Table 1. Design Parameters**

DESIGN PARAMETER	VALUE
WPC coil type	A11

## 8.2.2 Detailed Design Procedure

### 8.2.2.1 Capacitor Selection

Capacitor selection is critical to proper system operation. The total capacitance value of  $4\text{ nF} \times 100\text{ nF}$  is required in the resonant tank. This is the WPC system compatibility requirement, not a guideline.

---

#### NOTE

A total capacitance value of  $4\text{ nF} \times 100\text{ nF}$  (C0G dielectric type, 50-V rating) is required in the resonant tank to achieve the correct resonance frequency. The capacitors chosen must be rated for at least 50 V and must be of a high-quality C0G dielectric (sometimes also called NP0). These are typically available in a 5% tolerance, which is adequate. TI does **not** recommend the use of X7R types or below if WPC compliance is required because critical WPC Certification Testing, such as the minimum modulation or guaranteed power test, might fail. The designer can combine capacitors to achieve the desired capacitance value. Various combinations can work depending on market availability. All capacitors must be of C0G types (not mixed with any other dielectric types).

---

### 8.2.2.2 Current Monitoring Requirements

The bq50002A is WPC v1.2 ready. To enable the FOD feature, current monitoring is provided in the bq50002A Analog Front End. For proper scaling of the current monitor signal, the current sense resistor should be  $20\text{ m}\Omega$ . For FOD accuracy, the current sense resistor must be a quality component with 0.5% tolerance, at least 1/4-W rating, and a temperature stability of  $\pm 200\text{ PPM}$ .

### 8.2.2.3 Input Regulation

The bq500511A requires 3 VDC to operate. The regulator in the bq50002A provides this voltage rail eliminating the need for any external regulation.

### 8.2.2.4 System Input Power Requirements

The design works with 5-V input voltage to the bq50002A. The WPC defined A11 TX type requires 5-V system voltage in order to deliver 5 W of output power from the receiver.

### 8.2.3 Application Curves

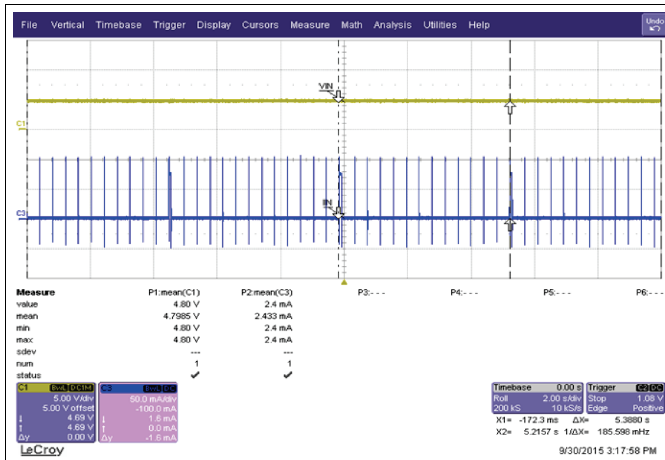

Figure 8. Standby Power

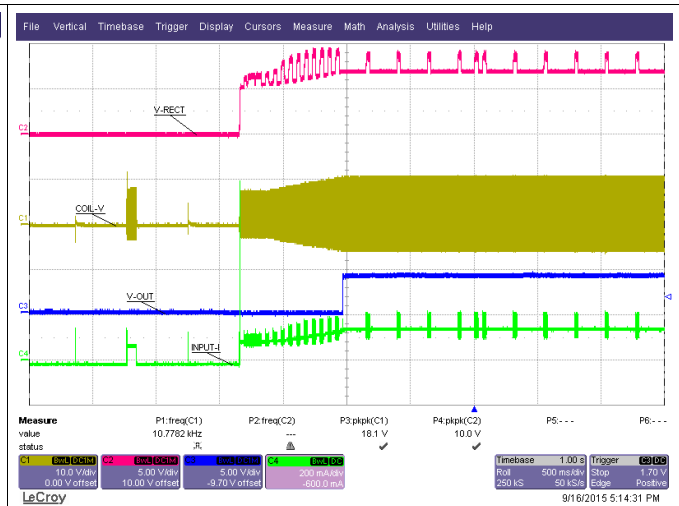

Figure 9. Start-Up with bq51013B

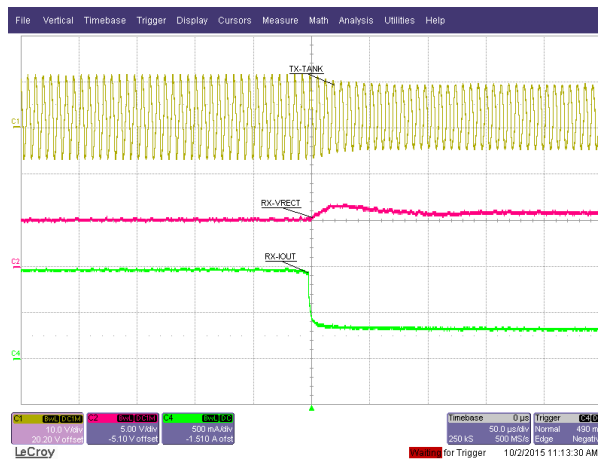

Figure 10. Load-Transient Response

## 9 Power Supply Recommendations

The A11 TX type requires a 5-V system voltage.

## 10 Layout

### 10.1 Layout Guidelines

Careful PCB layout practice is critical to proper system operation. Many references are available on proper PCB layout techniques. A few good tips are as follows.

The TX layout requires a 4-layer PCB layout for best ground plane technique. A 2-layer PCB layout can be achieved though not as easily. Ideally, the approach to the layer stack-up is:

- Layer 1 component placement and as much ground plane as possible
- Layer 2 clean ground
- Layer 3 finish routing
- Layer 4 clean ground

Thus, the circuitry is virtually sandwiched between grounds. This minimizes EMI noise emissions and also provides a noise-free voltage reference plane for device operation.

Keep as much copper as possible. Make sure the bq500511A GND pins have a continuous flood connection to the ground plane. The power pad of the bq50002A should also be stitched to the ground plane, which also acts as a heat sink. A good GND reference is necessary for proper system operation, such as analog-digital conversion, clock stability, and best overall EMI performance. Separate the analog ground plane from the power ground plane and use only **one** tie point to connect grounds. Having several tie points defeats the purpose of separating the grounds. See the bq50002 EVM, [SLVUAJ7](#), for an example of a good layout technique.

#### 10.1.1 Layout Notes

Make sure the bypass capacitors intended for the bq500511A 3.3-V supply are actually bypassing these supply pins (pin 32, DVCC, and pin 40, AVCC) to solid ground plane (see [Figure 11](#)). This means they need to be placed as close to the device as possible and the traces must be as wide as possible.

Make sure the bq500511A has a continuous flood connection to the ground plane (see [Figure 12](#)).

The full-bridge power stage that drives the TX coil is composed of two half-bridge power stages (integrated in bq50002A) and resonant capacitors. Input bypass capacitors should be placed as close as possible to the bq50002A PVIN1 pins (pin 27, 28) and PVIN2 pins (pin 14, 15). The input and ground pours and traces should be made as wide as possible for better current flow. The trace to the coil and resonant capacitors should also be made as wide as possible (see [Figure 13](#)).

To ensure proper operation, grounds conducting a large amount of current and switching noise must be isolated from low current, quiet grounds. Separate the ground pours for the power stages and the bq500511A IC. Connect all grounds to a single point at the main ground terminal (see [Figure 13](#)).

Proper current sensing layout technique is very important, as it directly affects the FOD and PMOD performance. When sampling the very-low voltages generated across a current sense resistor, be sure to use the so called 4-wire or Kelvin-connection technique. This is important to avoid introducing false voltage drops from adjacent pads and copper power routes. It is a common power-supply layout technique. Some high-accuracy sense resistors have dedicated sense pins (see [Figure 15](#)).

The trace from bq50002A CSP pin to sense resistor must be minimized to avoid unwanted offset in the application. This trace should be limited to less than 20 mΩ resistance.

## 10.2 Layout Examples

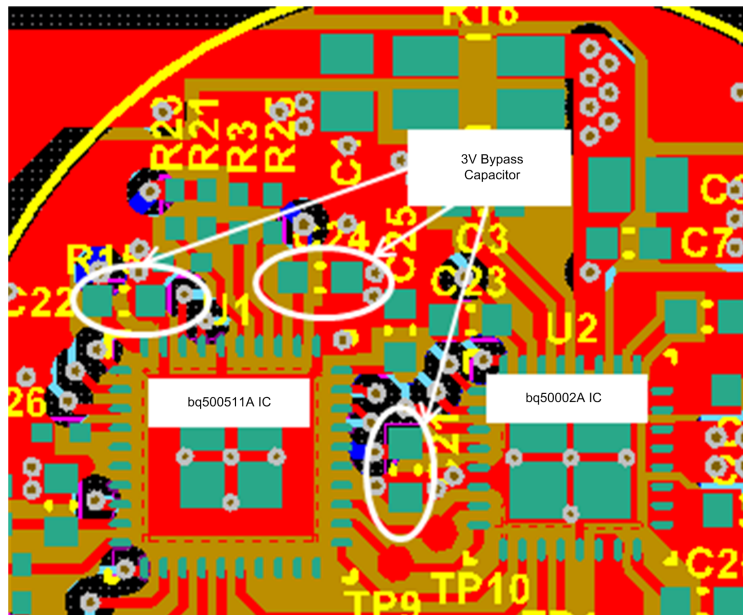

**Figure 11. Bypass Capacitors Layout**

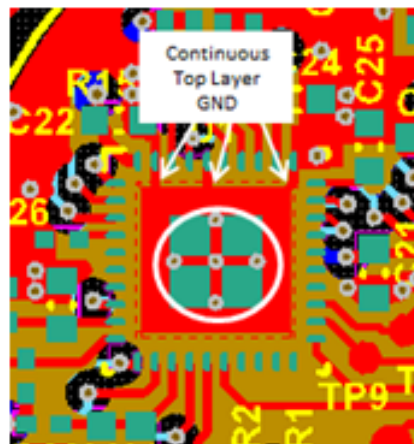

**Figure 12. Continuous GND Layout**

Layout Examples (continued)

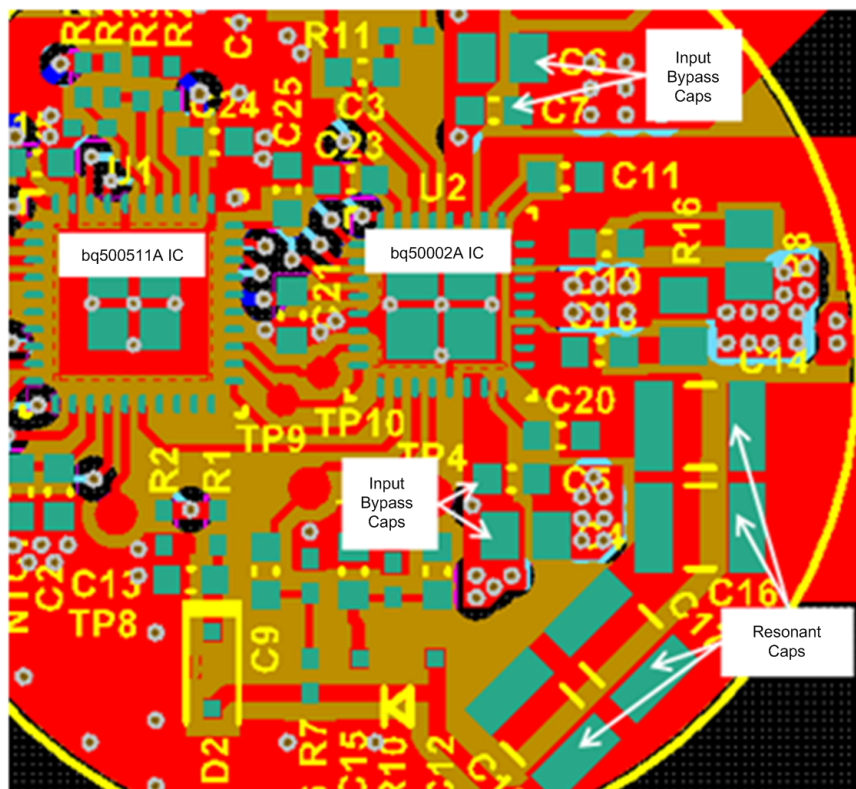

Figure 13. Ground Layout

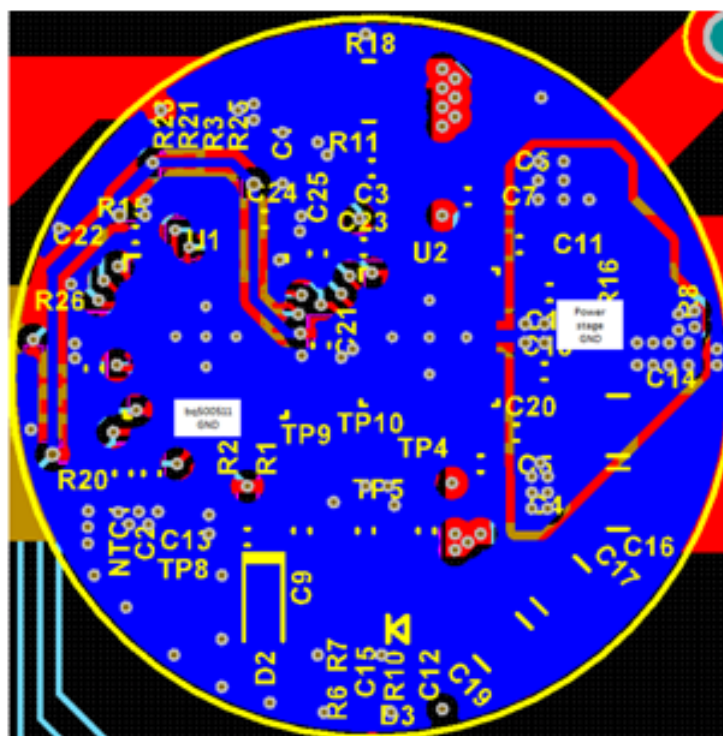
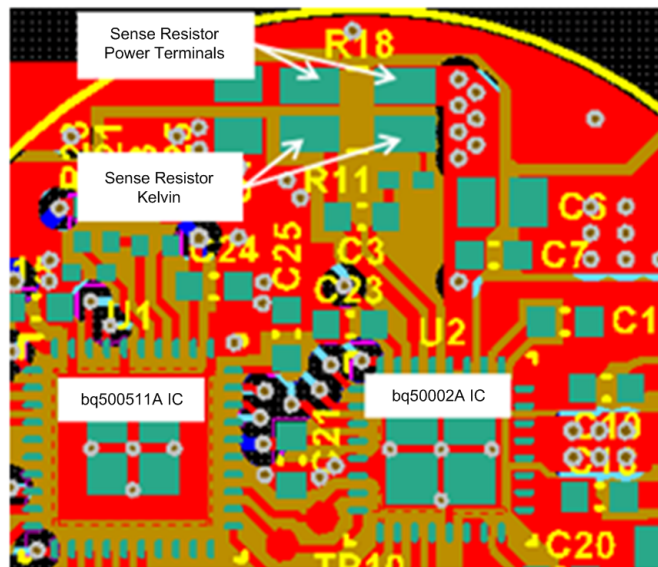

Figure 14. Ground Layout

**Layout Examples (continued)**



**Figure 15. Current Sensing Layout**

## 11 器件和文档支持

### 11.1 文档支持

#### 11.1.1 相关文档

1. 数据表《bq500511A 无线电源发送器控制器》（文献编号：SLUSCN3）
2. 评估模块《bq50002 无线电源 Tx EVM》（文献编号：SLVUAJ7）

### 11.2 接收文档更新通知

如需接收文档更新通知，请访问 [www.ti.com.cn](http://www.ti.com.cn) 网站上的器件产品文件夹。点击右上角的提醒我 (Alert me) 注册后，即可每周定期收到已更改的产品信息。有关更改的详细信息，请查阅已修订文档中包含的修订历史记录。

### 11.3 社区资源

The following links connect to TI community resources. Linked contents are provided "AS IS" by the respective contributors. They do not constitute TI specifications and do not necessarily reflect TI's views; see TI's [Terms of Use](#).

**TI E2E™ Online Community TI's Engineer-to-Engineer (E2E) Community.** Created to foster collaboration among engineers. At [e2e.ti.com](http://e2e.ti.com), you can ask questions, share knowledge, explore ideas and help solve problems with fellow engineers.

**Design Support TI's Design Support** Quickly find helpful E2E forums along with design support tools and contact information for technical support.

### 11.4 商标

动态电源限制 (DPL), E2E are trademarks of Texas Instruments.  
All other trademarks are the property of their respective owners.

### 11.5 静电放电警告



这些装置包含有限的内置 ESD 保护。存储或装卸时，应将导线一起截短或将装置放置于导电泡棉中，以防止 MOS 门极遭受静电损伤。

### 11.6 Glossary

**SLYZ022** — *TI Glossary*.

This glossary lists and explains terms, acronyms, and definitions.

## 12 机械、封装和可订购信息

以下页中包括机械、封装和可订购信息。这些信息是针对指定器件可提供的最新数据。这些数据会在无通知且不对本文档进行修订的情况下发生改变。欲获得该数据表的浏览器版本，请查阅左侧的导航栏。

**PACKAGING INFORMATION**

Orderable part number	Status (1)	Material type (2)	Package   Pins	Package qty   Carrier	RoHS (3)	Lead finish/ Ball material (4)	MSL rating/ Peak reflow (5)	Op temp (°C)	Part marking (6)
<a href="#">BQ50002ARHBR</a>	NRND	Production	VQFN (RHB)   32	3000   LARGE T&R	Yes	NIPDAU	Level-1-260C-UNLIM	-40 to 125	Q50002A
BQ50002ARHBT	NRND	Production	VQFN (RHB)   32	250   SMALL T&R	Yes	NIPDAU	Level-1-260C-UNLIM	-40 to 125	Q50002A

(1) **Status:** For more details on status, see our [product life cycle](#).

(2) **Material type:** When designated, preproduction parts are prototypes/experimental devices, and are not yet approved or released for full production. Testing and final process, including without limitation quality assurance, reliability performance testing, and/or process qualification, may not yet be complete, and this item is subject to further changes or possible discontinuation. If available for ordering, purchases will be subject to an additional waiver at checkout, and are intended for early internal evaluation purposes only. These items are sold without warranties of any kind.

(3) **RoHS values:** Yes, No, RoHS Exempt. See the [TI RoHS Statement](#) for additional information and value definition.

(4) **Lead finish/Ball material:** Parts may have multiple material finish options. Finish options are separated by a vertical ruled line. Lead finish/Ball material values may wrap to two lines if the finish value exceeds the maximum column width.

(5) **MSL rating/Peak reflow:** The moisture sensitivity level ratings and peak solder (reflow) temperatures. In the event that a part has multiple moisture sensitivity ratings, only the lowest level per JEDEC standards is shown. Refer to the shipping label for the actual reflow temperature that will be used to mount the part to the printed circuit board.

(6) **Part marking:** There may be an additional marking, which relates to the logo, the lot trace code information, or the environmental category of the part.

Multiple part markings will be inside parentheses. Only one part marking contained in parentheses and separated by a "~" will appear on a part. If a line is indented then it is a continuation of the previous line and the two combined represent the entire part marking for that device.

**Important Information and Disclaimer:** The information provided on this page represents TI's knowledge and belief as of the date that it is provided. TI bases its knowledge and belief on information provided by third parties, and makes no representation or warranty as to the accuracy of such information. Efforts are underway to better integrate information from third parties. TI has taken and continues to take reasonable steps to provide representative and accurate information but may not have conducted destructive testing or chemical analysis on incoming materials and chemicals. TI and TI suppliers consider certain information to be proprietary, and thus CAS numbers and other limited information may not be available for release.

In no event shall TI's liability arising out of such information exceed the total purchase price of the TI part(s) at issue in this document sold by TI to Customer on an annual basis.



**TAPE AND REEL INFORMATION**

**QUADRANT ASSIGNMENTS FOR PIN 1 ORIENTATION IN TAPE**

\*All dimensions are nominal

Device	Package Type	Package Drawing	Pins	SPQ	Reel Diameter (mm)	Reel Width W1 (mm)	A0 (mm)	B0 (mm)	K0 (mm)	P1 (mm)	W (mm)	Pin1 Quadrant
BQ50002ARHBR	VQFN	RHB	32	3000	330.0	12.4	5.3	5.3	1.1	8.0	12.0	Q2
BQ50002ARHBT	VQFN	RHB	32	250	180.0	12.4	5.3	5.3	1.1	8.0	12.0	Q2

**TAPE AND REEL BOX DIMENSIONS**

\*All dimensions are nominal

Device	Package Type	Package Drawing	Pins	SPQ	Length (mm)	Width (mm)	Height (mm)
BQ50002ARHBR	VQFN	RHB	32	3000	346.0	346.0	33.0
BQ50002ARHBT	VQFN	RHB	32	250	182.0	182.0	20.0

## GENERIC PACKAGE VIEW

**RHB 32**

**VQFN - 1 mm max height**

5 x 5, 0.5 mm pitch

PLASTIC QUAD FLATPACK - NO LEAD



Images above are just a representation of the package family, actual package may vary.  
Refer to the product data sheet for package details.

4224745/A

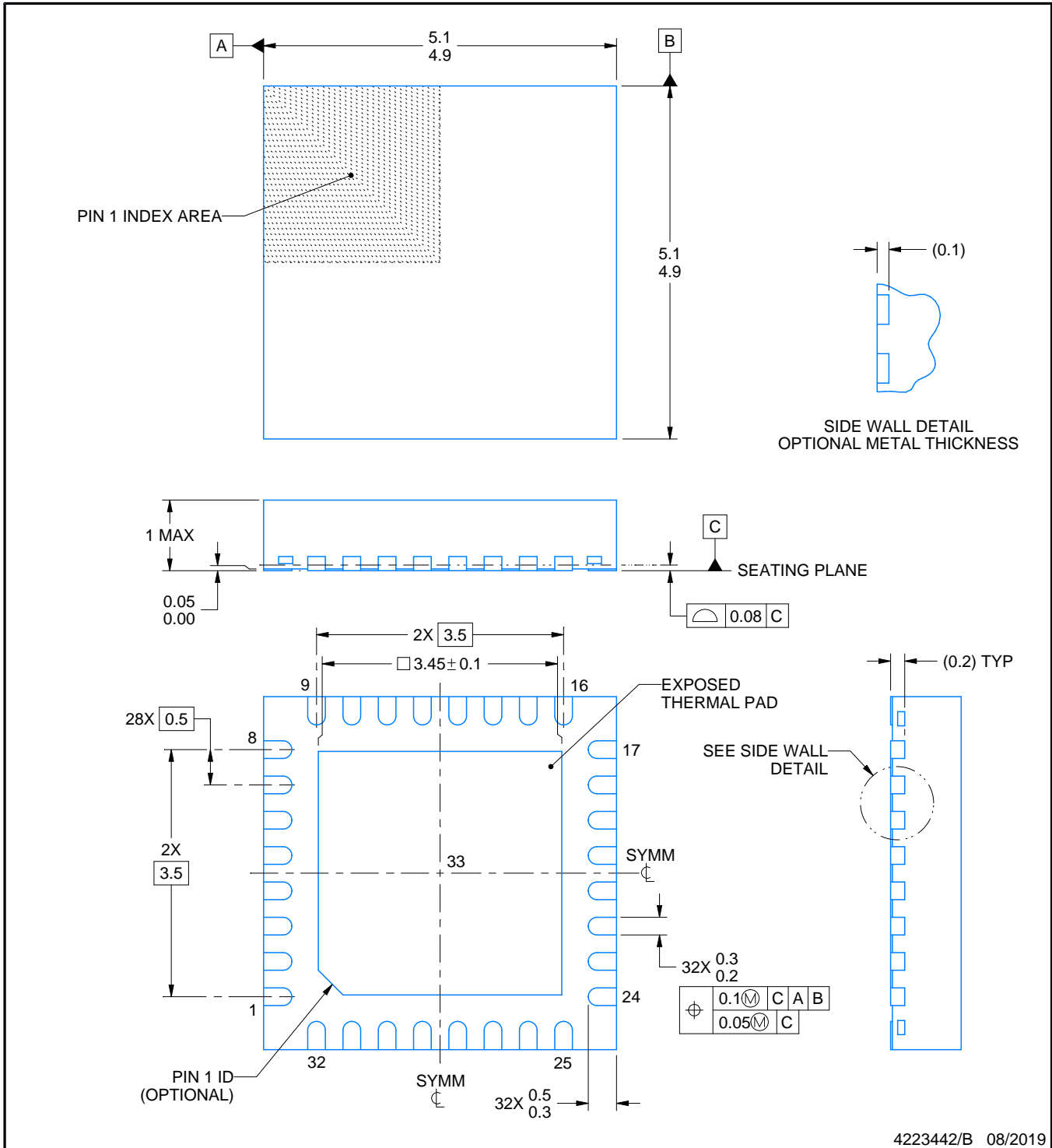

4223442/B 08/2019

NOTES:

1. All linear dimensions are in millimeters. Any dimensions in parenthesis are for reference only. Dimensioning and tolerancing per ASME Y14.5M.
2. This drawing is subject to change without notice.
3. The package thermal pad must be soldered to the printed circuit board for thermal and mechanical performance.

# EXAMPLE BOARD LAYOUT

RHB0032E

VQFN - 1 mm max height

PLASTIC QUAD FLATPACK - NO LEAD



LAND PATTERN EXAMPLE  
SCALE:18X



SOLDER MASK DETAILS

4223442/B 08/2019

NOTES: (continued)

4. This package is designed to be soldered to a thermal pad on the board. For more information, see Texas Instruments literature number SLUA271 ([www.ti.com/lit/sluea271](http://www.ti.com/lit/sluea271)).
5. Vias are optional depending on application, refer to device data sheet. If any vias are implemented, refer to their locations shown on this view. It is recommended that vias under paste be filled, plugged or tented.

# EXAMPLE STENCIL DESIGN

RHB0032E

VQFN - 1 mm max height

PLASTIC QUAD FLATPACK - NO LEAD



**SOLDER PASTE EXAMPLE**  
 BASED ON 0.125 mm THICK STENCIL

EXPOSED PAD 33:  
 75% PRINTED SOLDER COVERAGE BY AREA UNDER PACKAGE  
 SCALE:20X

4223442/B 08/2019

NOTES: (continued)

6. Laser cutting apertures with trapezoidal walls and rounded corners may offer better paste release. IPC-7525 may have alternate design recommendations.

## 重要通知和免责声明

TI“按原样”提供技术和可靠性数据（包括数据表）、设计资源（包括参考设计）、应用或其他设计建议、网络工具、安全信息和其他资源，不保证没有瑕疵且不做任何明示或暗示的担保，包括但不限于对适销性、某特定用途方面的适用性或不侵犯任何第三方知识产权的暗示担保。

这些资源可供使用 TI 产品进行设计的熟练开发人员使用。您将自行承担以下全部责任：(1) 针对您的应用选择合适的 TI 产品，(2) 设计、验证并测试您的应用，(3) 确保您的应用满足相应标准以及任何其他功能安全、信息安全、监管或其他要求。

这些资源如有变更，恕不另行通知。TI 授权您仅可将这些资源用于研发本资源所述的 TI 产品的相关应用。严禁以其他方式对这些资源进行复制或展示。您无权使用任何其他 TI 知识产权或任何第三方知识产权。您应全额赔偿因在这些资源的使用中对 TI 及其代表造成的任何索赔、损害、成本、损失和债务，TI 对此概不负责。

TI 提供的产品受 [TI 的销售条款](#) 或 [ti.com](#) 上其他适用条款/TI 产品随附的其他适用条款的约束。TI 提供这些资源并不会扩展或以其他方式更改 TI 针对 TI 产品发布的适用的担保或担保免责声明。

TI 反对并拒绝您可能提出的任何其他或不同的条款。

邮寄地址：Texas Instruments, Post Office Box 655303, Dallas, Texas 75265  
版权所有 © 2025，德州仪器 (TI) 公司