

# 具有电压基准和诊断 ADC 的 AFEx8101 16 位和 14 位低功耗 DAC，适用于 4mA 至 20mA 环路供电应用

## 1 特性

- 提供功能安全
  - 可帮助进行功能安全系统设计的文档：  
[AFE88101](#)、[AFE78101](#)
- 低静态电流：170  $\mu\text{A}$  (典型值)
- 16 位或 14 位单调高性能 DAC
  - 1.8V 电源：0.15V 至 1.25V，0.2V 至 1.0V
  - 5V 电源：0.3V 至 2.5V，0.4V 至 2.0V
  - 16 位时为 4-LSB INL
  - 40°C 至 +125°C 范围内的 TUE 为 0.07% FSR (最大值)
- 可实现高级诊断的 12 位 3.84kSPS ADC
- 集成 1.25V 基准电压，温漂为 10ppm/°C
- 具有时钟输出的内部 1.2288MHz 振荡器
- 数字接口：
  - 串行外设接口 (SPI)
  - 通用异步接收器/发送器 (UART)
- 故障检测：CRC 位错误检查、窗口式看门狗计时器、诊断 ADC
- 宽工作温度范围：-55°C 至 +125°C

## 2 应用

- 2 线变送器
- 4mA 至 20mA 环路供电应用
- [过程控制和工业自动化](#)
- 智能发送器
- PLC 或 DCS I/O 模块

## 3 说明

16 位 AFE88101 和 14 位 AFE78101 (AFEx8101) 是具有电压输出的高度集成、高精度、极低功耗的数模转换器 (DAC)，专为传感器变送器应用而设计。

AFEx8101 器件包含设计 4mA 至 20mA、2 线 (环路供电) 传感器变送器所需的大多数元件。除了高精度 DAC 之外，这些器件还包括一个 10ppm/°C 电压基准和一个诊断模数转换器 (ADC)。为了适应内在和功能安全问题，需要进行外部电压至电流转换和功率调节。

内部诊断 ADC 多路复用为多个内部节点，可实现自动自我运行状况检查。此检查能够检测内部偏置源、电源稳压器、电压基准、DAC 输出、芯片温度和可选外部电压源的错误或故障。如果从诊断 ADC、CRC 帧错误校验或窗口化看门狗计时器检测到任何故障，这些器件可以选择发出中断，进入与标准 NAMUR 输出值和/或用户指定的自定义值相对应的失效防护状态。

这些器件采用低至 1.71V 的电源供电，最大静态电流为 210 $\mu\text{A}$ 。这些器件的额定工作温度范围为 -40°C 至 +125°C，但工作温度范围为 -55°C 至 +125°C。

### 器件信息

器件型号	分辨率	封装 <sup>(1)</sup>
AFE78101	14 位	RRU (UQFN, 24)
AFE88101	16 位	4.00mm × 4.00mm

(1) 如需了解所有可用封装，请参阅数据表末尾的封装选项附录。

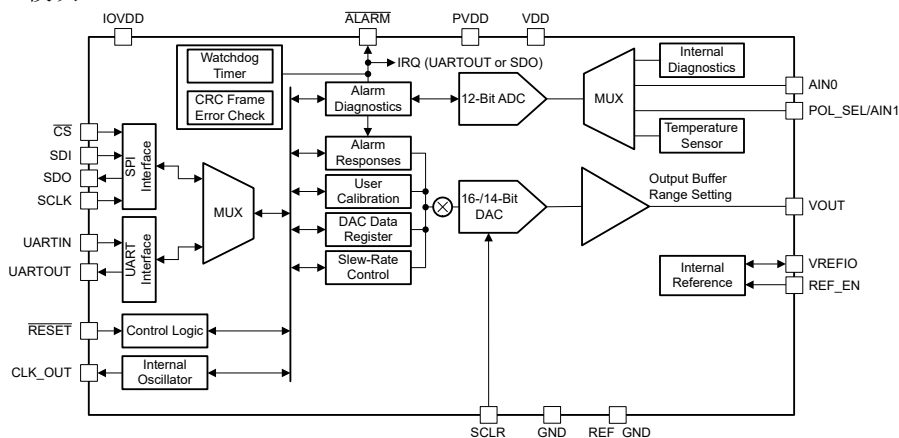

功能方框图



## Table of Contents

<b>1 特性</b> .....	<b>1</b>	7.3 Feature Description.....	<b>23</b>
<b>2 应用</b> .....	<b>1</b>	7.4 Device Functional Modes.....	<b>44</b>
<b>3 说明</b> .....	<b>1</b>	7.5 Programming.....	<b>46</b>
<b>4 Revision History</b> .....	<b>2</b>	7.6 Register Maps.....	<b>53</b>
<b>5 Pin Configuration and Functions</b> .....	<b>3</b>	<b>8 Application and Implementation</b> .....	<b>72</b>
<b>6 Specifications</b> .....	<b>5</b>	8.1 Application Information.....	<b>72</b>
6.1 Absolute Maximum Ratings.....	<b>5</b>	8.2 Typical Application.....	<b>73</b>
6.2 ESD Ratings.....	<b>5</b>	8.3 Initialization Set Up.....	<b>79</b>
6.3 Recommended Operating Conditions.....	<b>5</b>	8.4 Power Supply Recommendations.....	<b>80</b>
6.4 Thermal Information.....	<b>5</b>	8.5 Layout.....	<b>80</b>
6.5 Electrical Characteristics.....	<b>6</b>	<b>9 Device and Documentation Support</b> .....	<b>82</b>
6.6 Timing Requirements.....	<b>10</b>	9.1 Documentation Support .....	<b>82</b>
6.7 Timing Diagrams .....	<b>11</b>	9.2 接收文档更新通知.....	<b>82</b>
6.8 Typical Characteristics: VOUT DAC.....	<b>12</b>	9.3 支持资源.....	<b>82</b>
6.9 Typical Characteristics: ADC.....	<b>18</b>	9.4 Trademarks.....	<b>82</b>
6.10 Typical Characteristics: Reference.....	<b>19</b>	9.5 Electrostatic Discharge Caution.....	<b>82</b>
6.11 Typical Characteristics: Power Supply.....	<b>21</b>	9.6 术语表.....	<b>82</b>
<b>7 Detailed Description</b> .....	<b>22</b>	<b>10 Mechanical, Packaging, and Orderable Information</b> .....	<b>82</b>
7.1 Overview.....	<b>22</b>		
7.2 Functional Block Diagram.....	<b>22</b>		

## 4 Revision History

注：以前版本的页码可能与当前版本的页码不同

DATE	REVISION	NOTES
December 2022	*	Initial release.

## 5 Pin Configuration and Functions



图 5-1. RRU (24-pin UQFN) Package, Top View

表 5-1. Pin Functions

PIN		TYPE <sup>(1)</sup>	DESCRIPTION
NAME	NO.		
AIN0	15	AI	ADC input voltage. The input range is 0 V to VREF if PVDD = VDD, or 0 V to 2 × VREF if PVDD > 2.7 V.
ALARM	24	DO	Alarm notification. Open drain. When alarm condition is asserted, this pin is held to logic low; otherwise, this pin is in a high-impedance state (Hi-Z).
CLK_OUT	11	DO	Clock output. This pin can be configured as a clock output for the 1.2288-MHz internal clock.
CS	10	DI	SPI chip-select. Data bits are clocked into the serial shift register when CS is logic low. When CS is logic high, SDO is in a high-impedance state and data on SDI are ignored. Do not leave any digital input pins floating.
GND	14	P	Digital and analog ground. Ground reference point for all circuitry on the device.
GND	21, 22	P	Digital and analog ground.
IOVDD	12	P	Interface supply. Supply voltage for digital input and output circuitry. This voltage sets the logical thresholds for the digital interfaces.
NC	3, 23	-	No connection. Leave floating.
POL_SEL/AIN1	16	DI/AI	ADC input voltage if SPECIAL_CFG.AIN1_ENB bit is set to 1. The input range is 0 V to VREF if PVDD = VDD, or 0 V to 2 × VREF if PVDD > 2.7 V. Otherwise, this pin acts as ALMV_POL, which sets the polarity of the VOUT alarm voltage.
PVDD	17	P	Power supply for the internal low-dropout regulator (LDO), ADC input, and VOUT DAC output. When 2.7 V to 5.5 V is provided, the internal LDO turns on and drives VDD internally. When 1.71 V to 1.89 V is provided, the internal LDO is disabled.
REF_EN	5	DI	Internal VREF enable input. A logic high on this pin enables the internal VREF and the VREFIO pin outputs 1.25 V. A logic low on this pin disables the internal VREF and the external 1.25-V reference is required at the VREFIO pin.
REF_GND	20	P	GND reference for VREFIO pin.
RESET	6	DI	Reset. Logic low on this pin places the device into power-down mode and resets the device. Logic high returns the device to normal operation. Do not leave any digital input pins floating.

表 5-1. Pin Functions (continued)

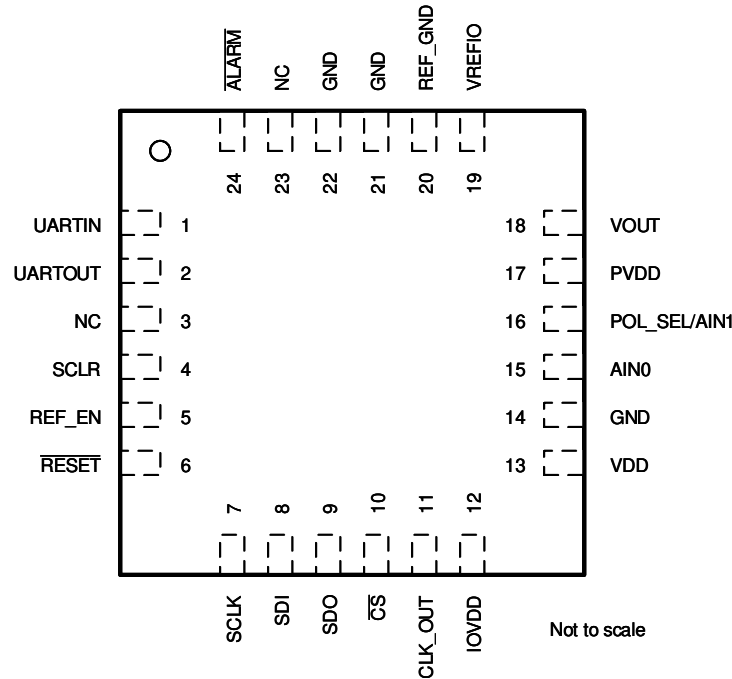
PIN		TYPE <sup>(1)</sup>	DESCRIPTION
NAME	NO.		
SCLK	7	DI	SPI serial clock. Data can be transferred at rates up to 12.5 MHz. SCLK is a Schmitt-trigger logic input. Connect to GND or logic low if not used. Do not leave any digital input pins floating.
SCLR	4	DI	DAC clear input pin in SPI mode. A logic high on this pin forces the DAC output into a CLEAR state. Connect to GND in UBM. Do not leave any digital input pins floating.
SDI	8	DI	SPI data input. Data are clocked into the 24-bit input shift register on the falling edge of the serial clock input. SDI is a Schmitt-Trigger logic input. Do not leave any digital input pins floating.
SDO	9	DO	SPI data output. Data are output on the rising edge of SCLK when $\overline{CS}$ is logic low. Interrupt request (IRQ) pin in the UART break mode (UBM). The output is in a Hi-Z state at power up and must be enabled in the CONFIG register.
UARTIN	1	DI	UART data input. Connect to IOVDD or logic high if not used. Do not leave any digital input pins floating.
UARTOUT	2	DO	UART data output. This pin can be configured to function as the IRQ pin in SPI only mode.
VDD	13	P/AO	Power supply. When 2.7 V to 5.5 V is provided on PVDD pin, the internal LDO drives VDD internally. Connect a 1- $\mu$ F to 10- $\mu$ F capacitor to this pin. When 1.71 V to 1.89 V is provided on the PVDD pin, an external power supply must be provided on this pin.
VOUT	18	AO	DAC output voltage.
VREFIO	19	AI/AO	When the internal VREF is enabled by REF_EN pin, this pin outputs the internal VREF voltage. In this case, a load capacitance of 70-nF to 130-nF is required for stability. When disabled, this pin is the external 1.25-V reference input.

(1) AI = analog input, AO = analog output, DI = digital input, DO = digital output, P = power.

## 6 Specifications

### 6.1 Absolute Maximum Ratings

over operating free-air temperature range (unless otherwise noted)<sup>(1)</sup>

			MIN	MAX	UNIT
Voltage		PVDD, IOVDD to GND	- 0.3	5.5	V
		VDD to GND	- 0.3	1.98	V
		AIN0, POL_SEL/AIN1, VOOUT to GND	- 0.3	PVDD + 0.3	V
		Digital Input/Output to GND	- 0.3	IOVDD + 0.3	V
		VREFIO to GND	- 0.3	VDD + 0.3	V
		REF_GND to GND	- 0.3	0.3	V
	Input current	Current into any pin	- 10	10	mA
T <sub>J</sub>	Junction temperature		- 55	150	°C
T <sub>stg</sub>	Storage temperature		- 65	150	

- (1) Operation outside the *Absolute Maximum Ratings* may cause permanent device damage. *Absolute Maximum Ratings* do not imply functional operation of the device at these or any other conditions beyond those listed under *Recommended Operating Conditions*. If used outside the *Recommended Operating Conditions* but within the *Absolute Maximum Ratings*, the device may not be fully functional, and this may affect device reliability, functionality, performance, and shorten the device lifetime.

### 6.2 ESD Ratings

			VALUE	UNIT
V <sub>(ESD)</sub>	Electrostatic discharge	Human body model (HBM), per ANSI/ESDA/JEDEC JS-001, all pins <sup>(1)</sup>	±2000	V
		Charged device model (CDM), per ANSI/ESDA/JEDEC JS-002, all pins <sup>(2)</sup>	±500	

- (1) JEDEC document JEP155 states that 500-V HBM allows safe manufacturing with a standard ESD control process.  
(2) JEDEC document JEP157 states that 250-V CDM allows safe manufacturing with a standard ESD control process.

### 6.3 Recommended Operating Conditions

over operating free-air temperature range (unless otherwise noted)

			MIN	NOM	MAX	UNIT
	PVDD to GND	PVDD > 2.7 V, VDD internally generated	2.7		5.5	V
		PVDD = VDD	1.71		1.89	V
	VDD to GND		1.71		1.89	V
	IOVDD to GND		1.71		5.5	V
	VREFIO to GND	External VREF	1.2	1.25	1.3	V
T <sub>A</sub>	Ambient temperature	Specified	- 40		125	°C
		Operating	- 55		125	

### 6.4 Thermal Information

THERMAL METRIC <sup>(1)</sup>		AFE8101	UNIT
		RRU (UQFN)	
		24 PINS	
R <sub>θJA</sub>	Junction-to-ambient thermal resistance	103.1	°C/W
R <sub>θJC(top)</sub>	Junction-to-case (top) thermal resistance	84.4	°C/W
R <sub>θJC(bottom)</sub>	Junction-to-case (bottom) thermal resistance	N/A	°C/W
R <sub>θJB</sub>	Junction-to-board thermal resistance	69.5	°C/W
Ψ <sub>JT</sub>	Junction-to-top characterization parameter	0.4	°C/W
Ψ <sub>JB</sub>	Junction-to-board characterization parameter	68.4	°C/W

- (1) For more information about traditional and new thermal metrics, see the [Semiconductor and IC Package Thermal Metrics application report](#).

## 6.5 Electrical Characteristics

all minimum and maximum values at  $T_A = -40^\circ\text{C}$  to  $+125^\circ\text{C}$  and all typical values at  $T_A = 25^\circ\text{C}$ ,  $PVDD = VDD = IOVDD = 1.8\text{ V}$ , external or internal  $VREFIO = 1.25\text{ V}$ ,  $R_{LOAD} = 50\text{ k}\Omega$  to GND,  $C_{LOAD} = 100\text{ pF}$  to GND, and digital inputs at  $IOVDD$  or GND (unless otherwise noted)

PARAMETER		TEST CONDITIONS	MIN	TYP	MAX	UNIT
<b>VOUT DAC STATIC PERFORMANCE</b>						
	Resolution	AFE88101	16			Bits
		AFE78101	14			
INL	Integral nonlinearity <sup>(1)</sup>	AFE88101	-4	4		LSB
		AFE78101	-2	2		
DNL	Differential nonlinearity <sup>(1)</sup>		-1	1		LSB
TUE	Total unadjusted error <sup>(1)</sup>	$T_A = -40^\circ\text{C}$ to $+125^\circ\text{C}$	-0.07	0.07		%FSR
		$T_A = -40^\circ\text{C}$ to $+85^\circ\text{C}$	-0.05	0.05		
		$T_A = 25^\circ\text{C}$	-0.04	0.04		
ZCE	Zero code error	$T_A = -40^\circ\text{C}$ to $+125^\circ\text{C}$	-0.07	0.07		%FSR
		$T_A = -40^\circ\text{C}$ to $+85^\circ\text{C}$	-0.05	0.05		
		$T_A = 25^\circ\text{C}$	-0.03	0.03		
ZCE-TC	Zero code error temperature coefficient		±3		ppm/°C	
OE	Offset error <sup>(1)</sup>	$T_A = -40^\circ\text{C}$ to $+125^\circ\text{C}$	-0.07	0.07		%FSR
		$T_A = -40^\circ\text{C}$ to $+85^\circ\text{C}$	-0.05	0.05		
		$T_A = 25^\circ\text{C}$	-0.03	0.03		
OE-TC	Offset error temperature coefficient <sup>(1)</sup>		±3		ppm/°C	
GE	Gain error <sup>(1)</sup>	$T_A = -40^\circ\text{C}$ to $+125^\circ\text{C}$	-0.04	0.04		%FSR
		$T_A = -40^\circ\text{C}$ to $+85^\circ\text{C}$	-0.04	0.04		
		$T_A = 25^\circ\text{C}$	-0.03	0.03		
GE-TC	Gain error temperature coefficient <sup>(1)</sup>		±3		ppm FSR/°C	
FSE	Full-scale error	$T_A = -40^\circ\text{C}$ to $+125^\circ\text{C}$	-0.07	0.07		%FSR
		$T_A = -40^\circ\text{C}$ to $+85^\circ\text{C}$	-0.06	0.06		
		$T_A = 25^\circ\text{C}$	-0.04	0.04		
FSE-TC	Full-scale error temperature coefficient		±3		ppm FSR/°C	
<b>VOUT DAC DYNAMIC PERFORMANCE</b>						
$t_s$	Output voltage settling time <sup>(4)</sup>	¼ to ¾ scale and ¾ to ¼ scale settling to ±2 LSB, $PVDD = VDD = 1.8\text{ V}$ , $VREFIO = 1.25\text{ V}$	65			µs
		10-mV step settling to ±2 LSB, $PVDD = VDD = 1.8\text{ V}$ , $VREFIO = 1.25\text{ V}$	30			
SR	Slew rate <sup>(4)</sup>	Fullscale transition measured from 10% to 90%	2			V/µs
$V_n$	Output noise <sup>(4)</sup>	0.1 Hz to 10 Hz, DAC at midscale, $PVDD = VDD = 1.8\text{ V}$ , $VREFIO = 1.25\text{ V}$	0.25			LSB <sub>pp</sub>
		100-kHz bandwidth, DAC at midscale, $PVDD = VDD = 1.8\text{ V}$ , $VREFIO = 1.25\text{ V}$	32			µV <sub>rms</sub>
$V_n$	Output noise density	Measured at 1 kHz, DAC at midscale, $PVDD = VDD = 1.8\text{ V}$ , $VREFIO = 1.25\text{ V}$	180			nV/√Hz
		Measured at 1 kHz, DAC at midscale, $PVDD = 5\text{ V}$ , $VREFIO = 1.25\text{ V}$	260			
	Power supply rejection ratio (AC)	200-mV 50-Hz to 60-Hz sine wave superimposed on power supply voltage, DAC at midscale.	85			dB
	Code change glitch impulse	Midcode ±1 LSB (including feedthrough) $PVDD = VDD = 1.8\text{ V}$ , $VREFIO = 1.25\text{ V}$	4.5			nV-s
	Code change glitch magnitude	Midcode ±1 LSB (including feedthrough) $PVDD = 5\text{ V}$ , $VREFIO = 1.25\text{ V}$	1.5			mV
	Digital feedthrough	At SCLK = 1 MHz, DAC output at midscale	1			nV-s

## 6.5 Electrical Characteristics (continued)

all minimum and maximum values at  $T_A = -40^\circ\text{C}$  to  $+125^\circ\text{C}$  and all typical values at  $T_A = 25^\circ\text{C}$ ,  $PVDD = VDD = IOVDD = 1.8\text{ V}$ , external or internal  $VREFIO = 1.25\text{ V}$ ,  $R_{LOAD} = 50\text{ k}\Omega$  to GND,  $C_{LOAD} = 100\text{ pF}$  to GND, and digital inputs at IOVDD or GND (unless otherwise noted)

PARAMETER		TEST CONDITIONS	MIN	TYP	MAX	UNIT
<b>VOUT DAC OUTPUT CHARACTERISTICS</b>						
	Output voltage range	RANGE = 0, PVDD = VDD	0.15		1.25	V
		RANGE = 1, PVDD = VDD	0.2		1.0	
		RANGE = 0, PVDD > 2.7 V, VDD generated	0.3		2.5	
		RANGE = 1, PVDD > 2.7 V, VDD generated	0.4		2.0	
	VOUT alarm output high	PVDD > 2.7 V, VDD internally generated	-6%	2.5	+6%	V
		PVDD = VDD	-6%	1.25	+6%	
	VOUT alarm output low	PVDD > 2.7 V, VDD internally generated	-5%	0.3	+5%	V
		PVDD = VDD	-5%	0.15	+5%	
$R_{LOAD}$	Resistive load <sup>(2)</sup>		10			k $\Omega$
$C_{LOAD}$	Capacitive load <sup>(2)</sup>				100	pF
	Load regulation	DAC at midscale, $-1\text{ mA} \leq I_{OUT} \leq +1\text{ mA}$		10		$\mu\text{V}/\text{mA}$
	Short-circuit current	Full scale output shorted to GND		5		mA
		Zero output shorted to VDD		5		
	Output voltage headroom to PVDD	DAC at full code, $I_{OUT} = 1\text{ mA}$ (sourcing)	200			mV
	Output voltage footroom to GND	DAC at zero code, $I_{OUT} = 1\text{ mA}$ (sinking)	200			mV
$Z_O$	DC small signal output impedance	DAC at midscale		10		m $\Omega$
		Output Hi-Z		500		k $\Omega$
	Power supply rejection ratio (dc)	DAC at midscale; PVDD = $1.8\text{ V} \pm 10\%$		0.1		mV/V
	Output voltage drift vs time, 1000 hours	$T_A = 35^\circ\text{C}$ , VOUT = midscale, ideal VREF		$\pm 5$		ppm FSR
<b>DIAGNOSTIC ADC</b>						
	Input voltage range	PVDD = VDD	0		1.25	V
		PVDD > 2.7 V	0		2.5	
	Resolution			12		Bits
DNL	Differential nonlinearity	Specified 12-bit monotonic	-1	$\pm 0.2$	1	LSB
INL	Integral nonlinearity		-4	$\pm 1$	4	LSB
OE	Offset error	After calibration	-10	$\pm 1.6$	10	LSB
GE	Gain error		-0.8	$\pm 0.13$	0.8	%FSR
	Noise			$\pm 4$		LSB
	Input capacitance			6		pF
	Input bias current	ADC not converting	-50		50	nA
	Acquisition time			52		$\mu\text{s}$
	Conversion time			210		$\mu\text{s}$
	Conversion rate				3.84	kSPS
	Temperature sensor accuracy			5		$^\circ\text{C}$
<b>INTERNAL OSCILLATOR</b>						
	Frequency	$T_A = -40^\circ\text{C}$ to $+125^\circ\text{C}$	1.2165	1.2288	1.2411	MHz

## 6.5 Electrical Characteristics (continued)

all minimum and maximum values at  $T_A = -40^\circ\text{C}$  to  $+125^\circ\text{C}$  and all typical values at  $T_A = 25^\circ\text{C}$ ,  $PVDD = VDD = IOVDD = 1.8\text{ V}$ , external or internal  $VREFIO = 1.25\text{ V}$ ,  $R_{LOAD} = 50\text{ k}\Omega$  to GND,  $C_{LOAD} = 100\text{ pF}$  to GND, and digital inputs at  $IOVDD$  or GND (unless otherwise noted)

PARAMETER		TEST CONDITIONS	MIN	TYP	MAX	UNIT
<b>VOLTAGE REFERENCE INPUT</b>						
$Z_{VREFIO}$	Reference input impedance (VREFIO)	RANGE = 0		125		k $\Omega$
		RANGE = 1		180		
$C_{VREFIO}$	Reference input capacitance (VREFIO)			100		pF
<b>VOLTAGE REFERENCE OUTPUT</b>						
	Output (initial accuracy) <sup>(3)</sup>	$T_A = 25^\circ\text{C}$	1.248	1.25	1.252	V
	Output drift <sup>(3)</sup>	$T_A = -40^\circ\text{C}$ to $+125^\circ\text{C}$			10	ppm/ $^\circ\text{C}$
	Output impedance <sup>(3)</sup>			0.1		$\Omega$
	Output noise <sup>(3)</sup>	0.1 Hz to 10 Hz		7.5		$\mu\text{V}_{PP}$
	Output noise density <sup>(3)</sup>	Measured at 10 kHz, reference load = 100 nF		200		nV/ $\sqrt{\text{Hz}}$
	Load current <sup>(3)</sup>	Sourcing, 0.1% VREF change from nominal		2.5		mA
		Sinking, 0.1% VREF change from nominal			0.3	
	Load regulation <sup>(3)</sup>	Sourcing, 0 mA to 2.5 mA		4		$\mu\text{V}/\text{mA}$
$C_{OUT}$	Stable output capacitance	$T_A = -40^\circ\text{C}$ to $+125^\circ\text{C}$ , ESR from 10 m $\Omega$ to 400 m $\Omega$	70	100	130	nF
	Line regulation <sup>(3)</sup>			80		$\mu\text{V}/\text{V}$
	Output voltage drift vs time <sup>(3)</sup>	$T_A = 35^\circ\text{C}$ , 1000 hours		$\pm 100$		ppm
	Thermal hysteresis <sup>(3)</sup>	1st cycle		500		$\mu\text{V}$
		Additional cycles			25	$\mu\text{V}$
<b>VDD VOLTAGE REGULATOR OUTPUT</b>						
	Output voltage		1.71	1.8	1.89	V
	Output impedance <sup>(3)</sup>	$PVDD = 3.3\text{ V}$ , sourcing, 0.5 mA to 2.5 mA		3		$\Omega$
	Load current <sup>(3)</sup>	$PVDD = 3.3\text{ V}$ , sourcing, 1% VDD change from nominal		4		mA
<b>THERMAL ALARM</b>						
	Alarm trip point			130		$^\circ\text{C}$
	Warning trip point			85		$^\circ\text{C}$
	Hysteresis			12		$^\circ\text{C}$
	Trip point absolute accuracy			5		$^\circ\text{C}$
	Trip point relative accuracy			2		$^\circ\text{C}$
<b>DIGITAL INPUT CHARACTERISTICS</b>						
$V_{IH}$	High-level input voltage		0.7			V/ $IOVDD$
$V_{IL}$	Low-level input voltage				0.3	V/ $IOVDD$
	Hysteresis voltage		0.05			V/ $IOVDD$
	Input current		-400		400	nA
	Pin capacitance	Per pin		10		pF
<b>DIGITAL OUTPUT CHARACTERISTICS</b>						
$V_{OH}$	High-level output voltage	$I_{SOURCE} = 1\text{ mA}$	0.8			V/ $IOVDD$
$V_{OL}$	Low-level output voltage	$I_{SINK} = 1\text{ mA}$			0.2	V/ $IOVDD$
$V_{OL}$	Open-drain low-level output voltage	$I_{SINK} = 2\text{ mA}$			0.3	V
	Output pin capacitance			10		pF



## 6.5 Electrical Characteristics (continued)

all minimum and maximum values at  $T_A = -40^\circ\text{C}$  to  $+125^\circ\text{C}$  and all typical values at  $T_A = 25^\circ\text{C}$ ,  $PVDD = VDD = IOVDD = 1.8\text{ V}$ , external or internal  $VREFIO = 1.25\text{ V}$ ,  $R_{LOAD} = 50\text{ k}\Omega$  to GND,  $C_{LOAD} = 100\text{ pF}$  to GND, and digital inputs at  $IOVDD$  or GND (unless otherwise noted)

PARAMETER		TEST CONDITIONS	MIN	TYP	MAX	UNIT
<b>POWER REQUIREMENTS</b>						
$I_{PVDD}$	Current flowing into PVDD	PVDD only, VDD internally generated, DAC at zero-scale, ADC and SPI static, internal reference		170	210	$\mu\text{A}$
		Shared PVDD and VDD connection, DAC at zero-scale, ADC and SPI static		32	45	
$I_{LDO}$	VDD LDO quiescent current	From PVDD		8		$\mu\text{A}$
$I_{VDD}$	Current flowing into VDD	Shared PVDD and VDD connection, DAC at zero-scale, ADC and SPI static, internal reference		130	160	$\mu\text{A}$
$I_{REFIO}$	Internal reference current consumption	From external or internally generated VDD		52	70	$\mu\text{A}$
$I_{ADC}$	ADC current consumption	From PVDD, ADC converting at 3.84 kSPS		10		$\mu\text{A}$
$C_{VDD}$	Recommended VDD decoupling capacitance		1		10	$\mu\text{F}$
$I_{IOVDD}$	Current flowing into IOVDD	SPI static		5	20	$\mu\text{A}$
$I_{VREFIO}$	Current flowing into VREFIO	0.15-V to 1.25-V range, midscale code		10		$\mu\text{A}$

- (1) End point fit between code 0 to code 65,535 for 16-bit, code 0 to code 16,383 for 14-bit, DAC output unloaded, performance under resistive and capacitive load conditions are specified by design and characterization.
- (2) Not production tested.
- (3) Derived from the characterization data.
- (4) Output buffer gain (G) = 2,  $PVDD > 2.7\text{ V}$ .

## 6.6 Timing Requirements

all input signals are specified with  $t_R = t_F = 1 \text{ ns/V}$  and timed from a voltage level of  $(V_{IL} + V_{IH}) / 2$ ,  $2.7 \text{ V} \leq PVDD \leq 5.5 \text{ V}$ ,  $V_{IH} = 1.62 \text{ V}$ ,  $V_{IL} = 0.15 \text{ V}$ ,  $V_{REFIO} = 1.25 \text{ V}$ , and  $T_A = -40^\circ\text{C}$  to  $+125^\circ\text{C}$  (unless otherwise noted)

PARAMETER		MIN	NOM	MAX	UNIT
<b>SERIAL INTERFACE - WRITE AND READ OPERATION</b>					
$f_{SCLK}$	Serial clock frequency			12.5	MHz
$t_{SCLKHIGH}$	SCLK high time	36			ns
$t_{SCLKLOW}$	SCLK low time	36			ns
$t_{CSHIGH}$	$\overline{CS}$ high time	80			ns
$t_{CSS}$	$\overline{CS}$ to SCLK falling edge setup time	30			ns
$t_{CSH}$	SCLK falling edge to $\overline{CS}$ rising edge	30			ns
$t_{CSRI}$	$\overline{CS}$ rising edge to SCLK falling edge ignore	30			ns
$t_{CSFI}$	SCLK falling edge ignore to $\overline{CS}$ falling edge	5			ns
$t_{SDIS}$	SDI setup time	5			ns
$t_{SDIH}$	SDI hold time	5			ns
$t_{SDOZD}$	$\overline{CS}$ falling edge to SDO tri-state condition to driven			40	ns
$t_{SDODZ}$	$\overline{CS}$ rising edge to SDO driven to tri-state condition			40	ns
$t_{SDODLY}$	SCLK to SDO output delay			40	ns
<b>UART</b>					
$t_{BAUD}$	Baud rate = $9600 \pm 1\%$		104		$\mu\text{s}$
<b>DIGITAL LOGIC</b>					
$t_{DACWAIT}$	Sequential DAC update wait time	2.1			$\mu\text{s}$
$t_{POR}$	POR reset delay			100	$\mu\text{s}$
$t_{RESET}$	$\overline{RESET}$ pulse duration	100			ns
$t_{RESETWAIT}$	Wait time after $\overline{RESET}$ pulse	10			$\mu\text{s}$

## 6.7 Timing Diagrams



图 6-1. SPI Timing



图 6-2. UBM Timing

## 6.8 Typical Characteristics: VOUT DAC

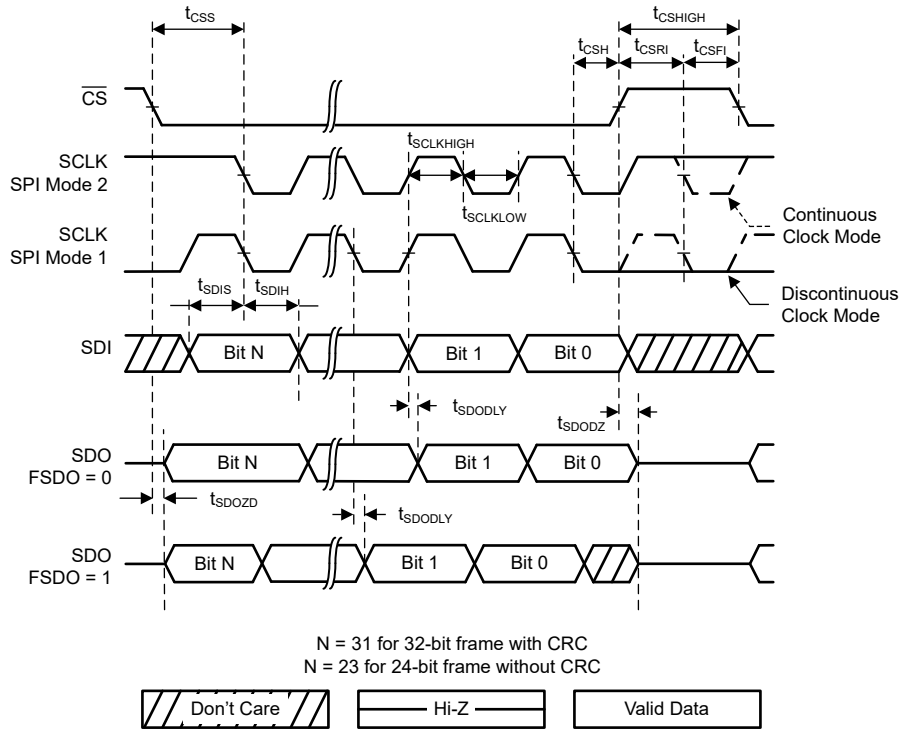
at  $T_A = 25^\circ\text{C}$ ,  $PVDD = VDD = IOVDD = 1.8\text{ V}$ , external or internal  $VREFIO = 1.25\text{ V}$ ,  $R_{LOAD} = 50\text{ k}\Omega$  to GND,  $C_{LOAD} = 100\text{ pF}$  to GND, and digital inputs at  $IOVDD$  or GND (unless otherwise noted)

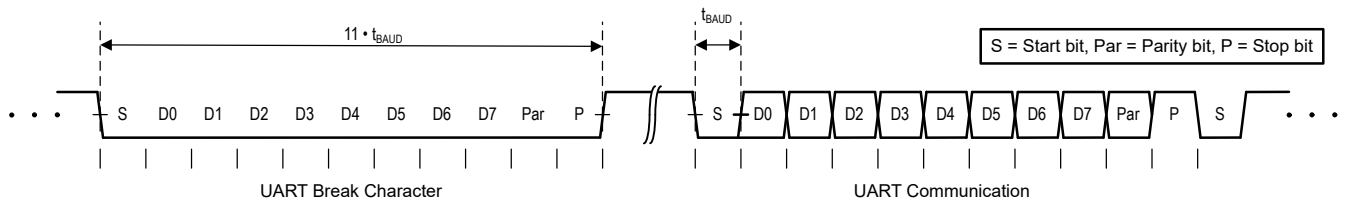

图 6-3. DAC DNL vs Digital Input Code



图 6-4. DAC DNL vs Digital Input Code

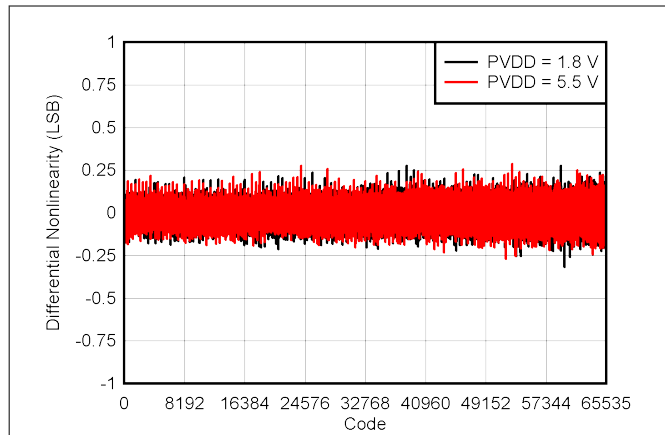

图 6-5. DAC INL vs Digital Input Code

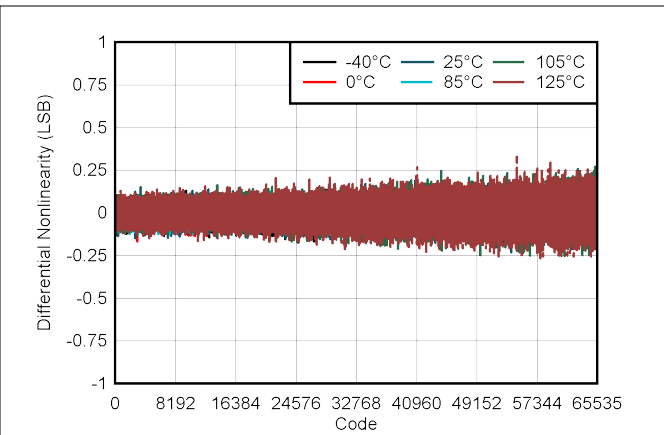

图 6-6. DAC INL vs Digital Input Code

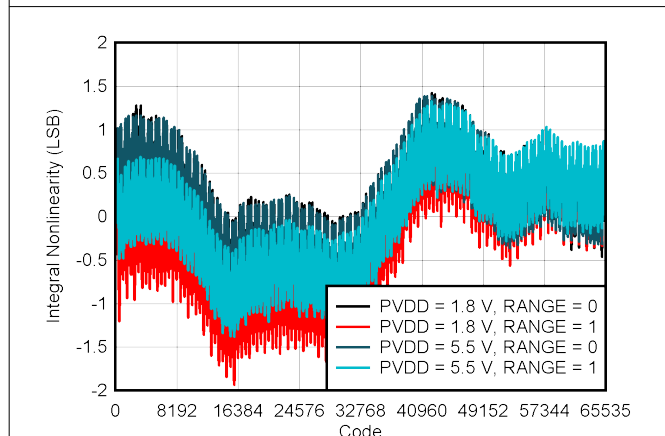

图 6-7. MIN and MAX DAC DNL Range vs Temperature

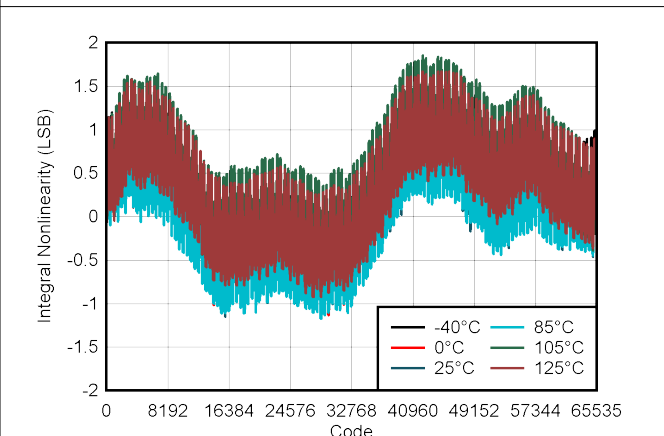

图 6-8. MIN and MAX DAC INL Range vs Temperature

### 6.8 Typical Characteristics: VOUT DAC (continued)

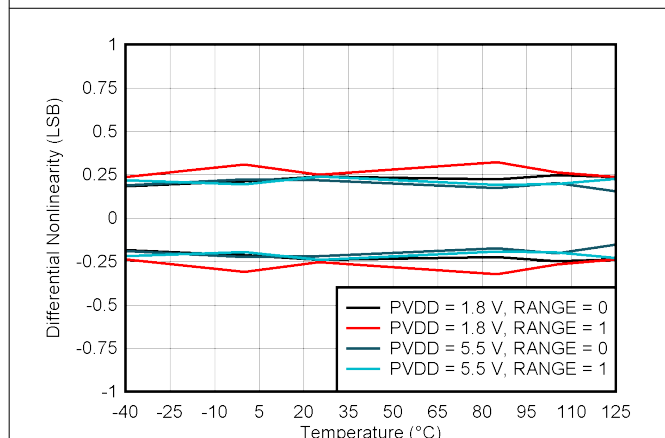
at  $T_A = 25^\circ\text{C}$ ,  $PVDD = VDD = IOVDD = 1.8\text{ V}$ , external or internal  $VREFIO = 1.25\text{ V}$ ,  $R_{LOAD} = 50\text{ k}\Omega$  to GND,  $C_{LOAD} = 100\text{ pF}$  to GND, and digital inputs at  $IOVDD$  or GND (unless otherwise noted)

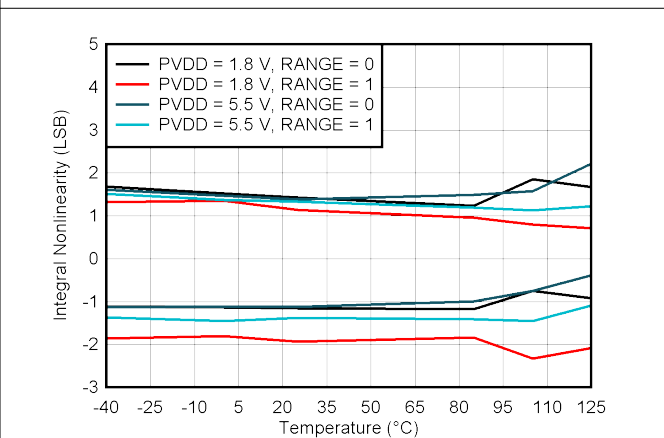

图 6-9. DAC TUE vs Digital Input Code



图 6-10. DAC TUE vs Digital Input Code

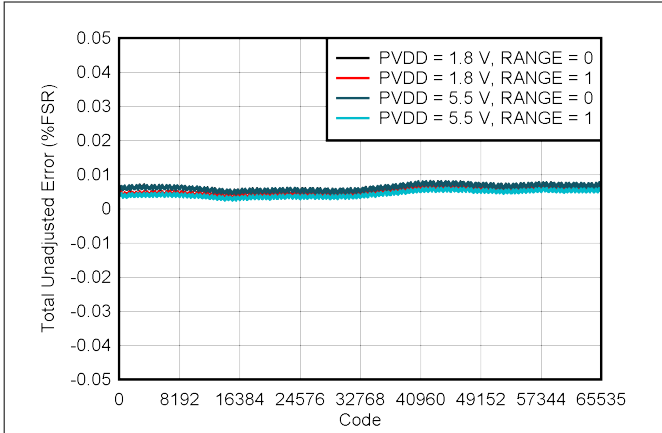

图 6-11. MIN and MAX DAC TUE vs Temperature

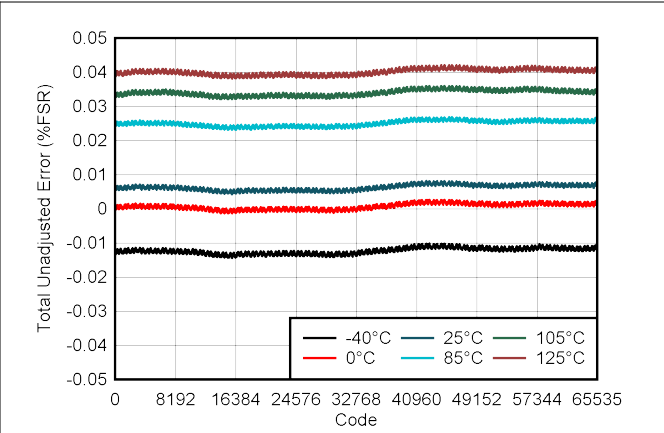

图 6-12. DAC RESET Response

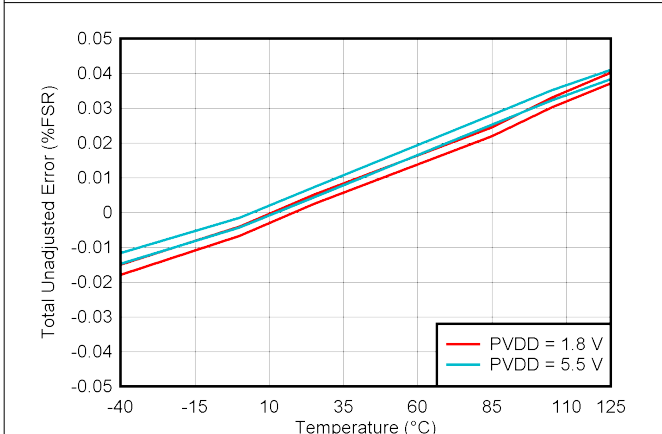

RANGE = 0

图 6-13. DAC Source and Sink Current Capability

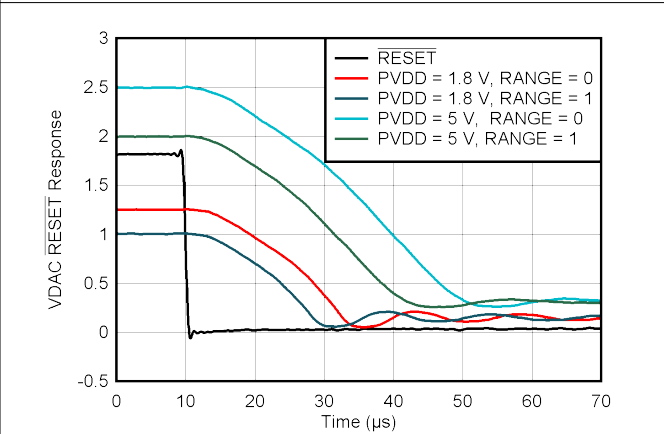
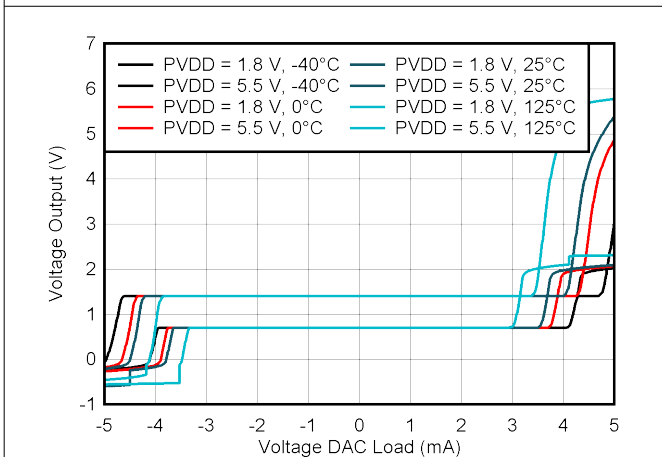
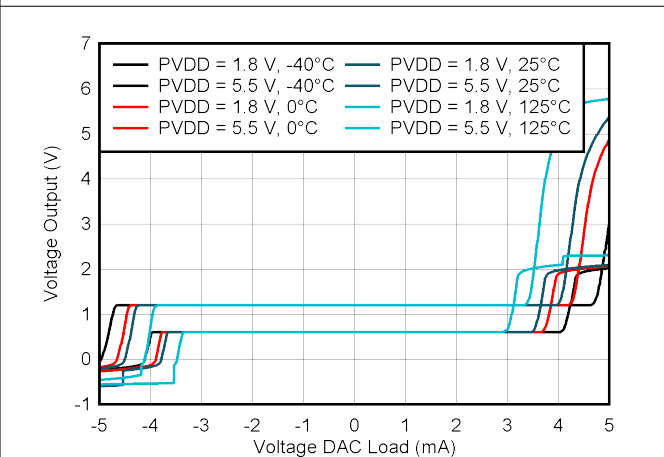

RANGE = 1

图 6-14. DAC Source and Sink Current Capability

## 6.8 Typical Characteristics: VOUT DAC (continued)

at  $T_A = 25^\circ\text{C}$ ,  $PVDD = VDD = IOVDD = 1.8\text{ V}$ , external or internal  $VREFIO = 1.25\text{ V}$ ,  $R_{LOAD} = 50\text{ k}\Omega$  to GND,  $C_{LOAD} = 100\text{ pF}$  to GND, and digital inputs at IOVDD or GND (unless otherwise noted)



图 6-15. DAC Gain Error vs Temperature



图 6-16. DAC Offset Error vs Temperature

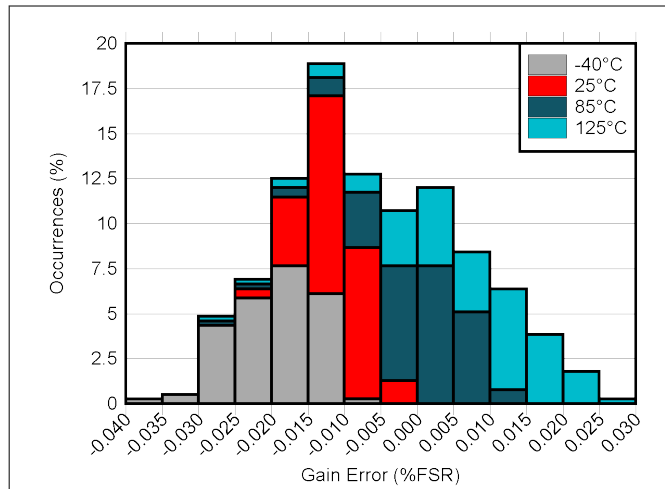

图 6-17. DAC Full Scale Error vs Temperature

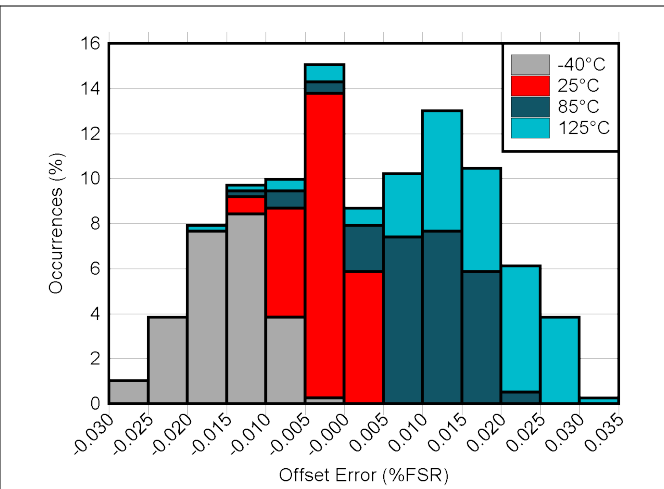

图 6-18. DAC Zero Scale Error vs Temperature

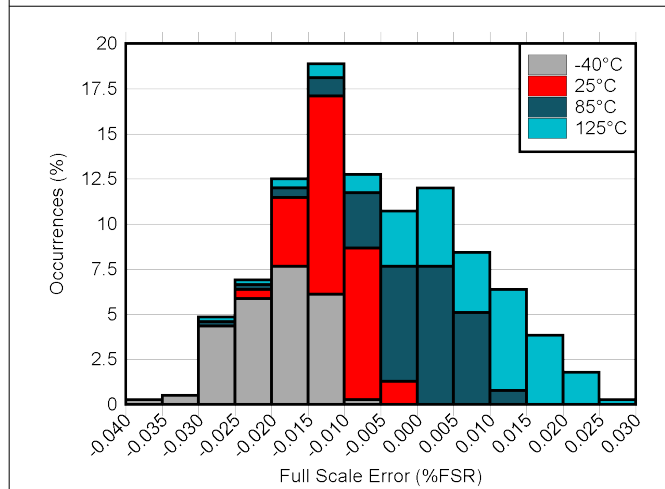

DAC at midcode

图 6-19. DAC Output Noise, 0.1 Hz to 10 Hz

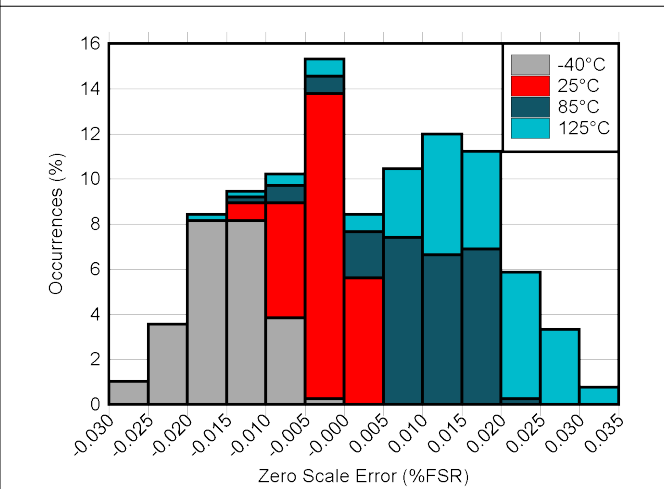
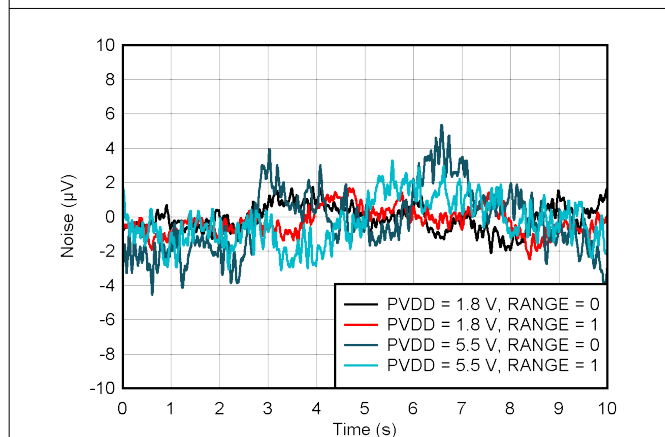
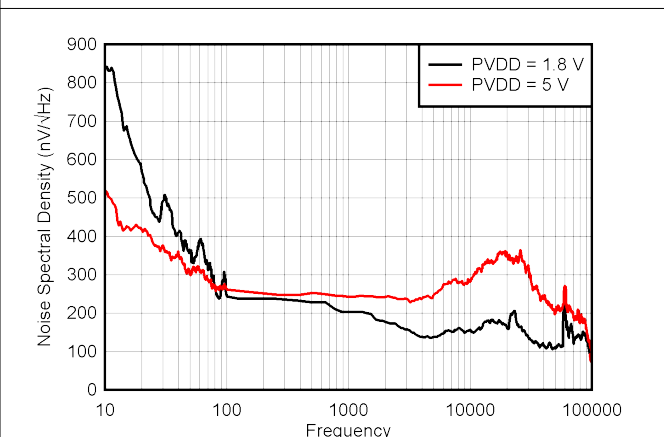

DAC at midcode

图 6-20. DAC Output Noise Density vs Frequency

### 6.8 Typical Characteristics: VOUT DAC (continued)

at  $T_A = 25^\circ\text{C}$ ,  $PVDD = VDD = IOVDD = 1.8\text{ V}$ , external or internal  $VREFIO = 1.25\text{ V}$ ,  $R_{LOAD} = 50\text{ k}\Omega$  to GND,  $C_{LOAD} = 100\text{ pF}$  to GND, and digital inputs at  $IOVDD$  or GND (unless otherwise noted)



图 6-21. DAC Settling Time vs Load (Rising Voltage Step)



图 6-22. DAC Settling Time vs Load (Falling Voltage Step)

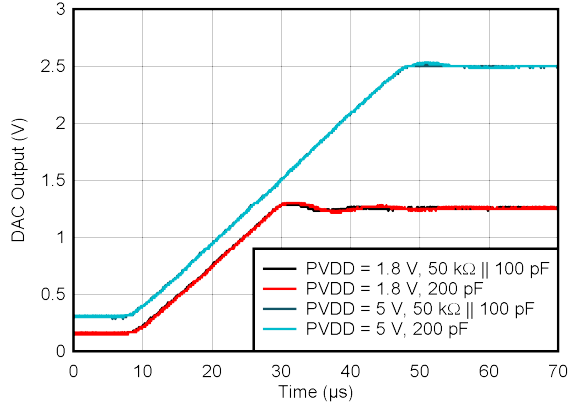

图 6-23. DAC Settling Time With Linear Slew Rate Control

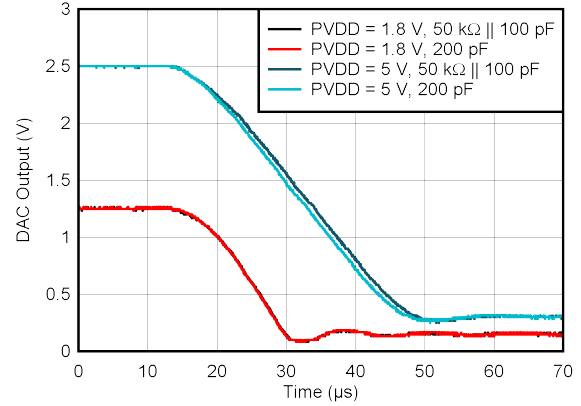

图 6-24. DAC Settling Time With Sinusoidal Slew Rate Control

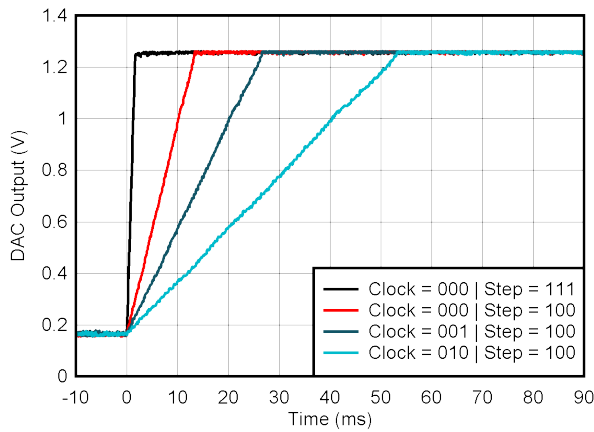

图 6-25. DAC Glitch Impulse Rising Edge

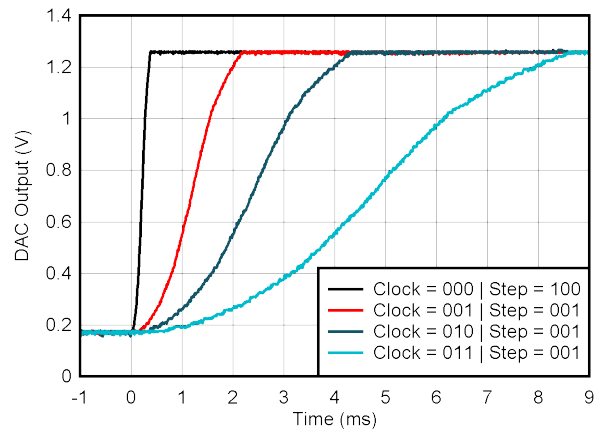

图 6-26. DAC Glitch Impulse Falling Edge

## 6.8 Typical Characteristics: VOUT DAC (continued)

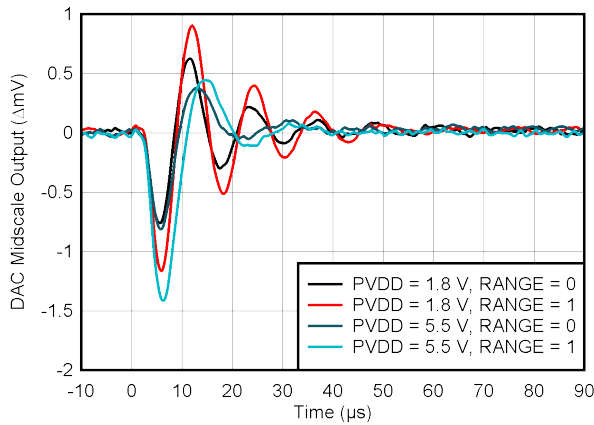
at  $T_A = 25^\circ\text{C}$ , PVDD = VDD = IOVDD = 1.8 V, external or internal VREFIO = 1.25 V,  $R_{LOAD} = 50\text{ k}\Omega$  to GND,  $C_{LOAD} = 100\text{ pF}$  to GND, and digital inputs at IOVDD or GND (unless otherwise noted)

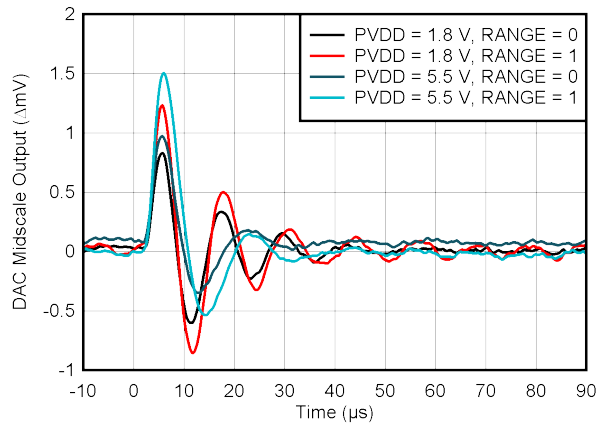

图 6-27. DAC Supply Power On, PVDD = 1.8 V



图 6-28. DAC Supply Power On, PVDD = 3.3 V

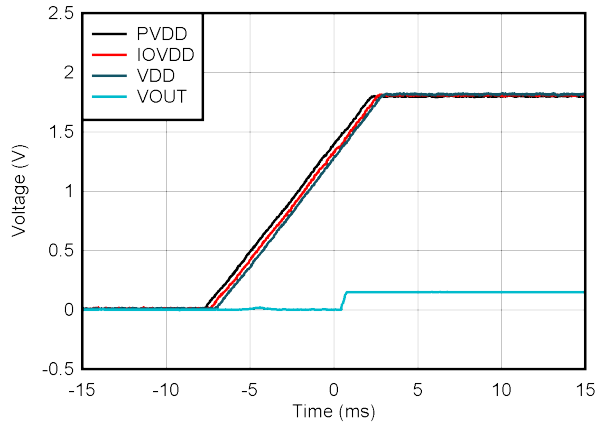

1: 0.4-V to 2-V range, midcode      3: 0.3-V to 2.2-V range, zero code  
2: 0.2-V to 1-V range, midcode

图 6-29. DAC PVDD Supply Collapse Response, RANGE = 1

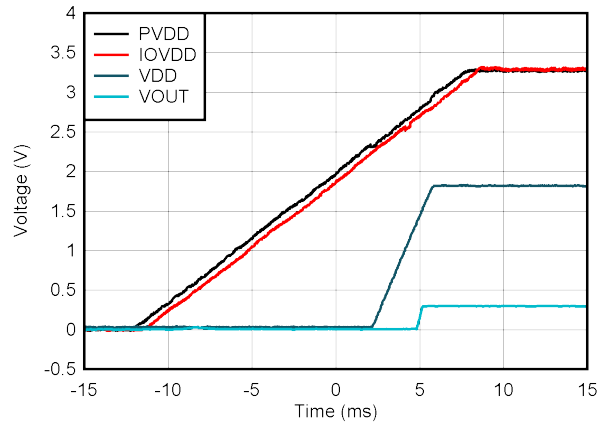
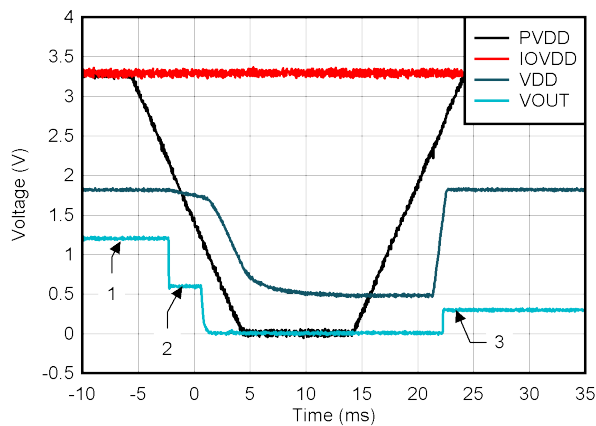
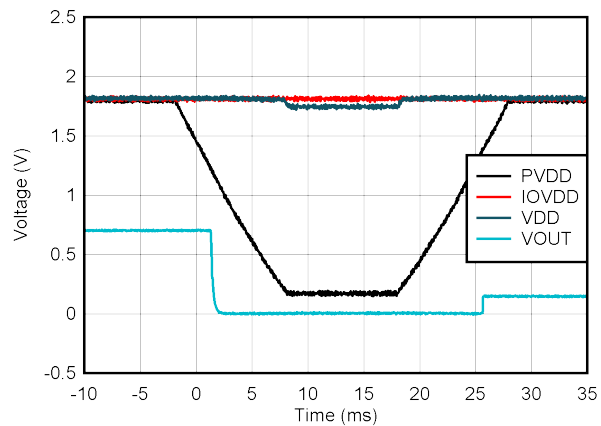

0.15-V to 1.25-V range, midcode

图 6-30. DAC PVDD Supply Collapse Response, RANGE = 0

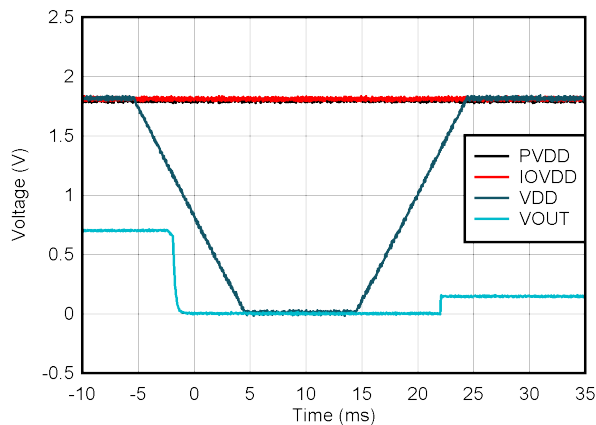

0.15-V to 1.25-V range, midcode

图 6-31. DAC VDD Supply Collapse Response, RANGE = 0

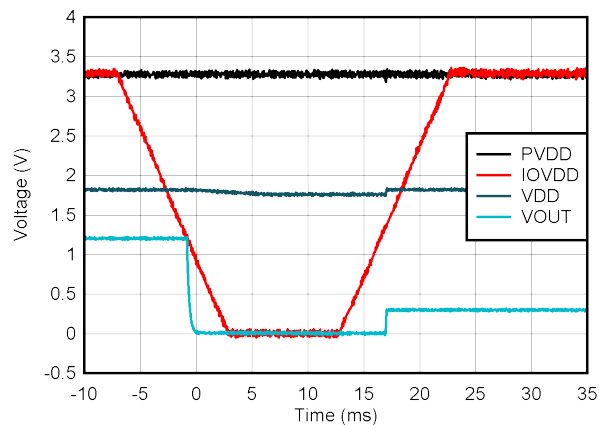

0.4-V to 2-V range, midcode

图 6-32. DAC IOVDD Supply Collapse Response, RANGE = 1



### 6.8 Typical Characteristics: VOUT DAC (continued)

at  $T_A = 25^\circ\text{C}$ ,  $PVDD = VDD = IOVDD = 1.8\text{ V}$ , external or internal  $VREFIO = 1.25\text{ V}$ ,  $R_{LOAD} = 50\text{ k}\Omega$  to GND,  $C_{LOAD} = 100\text{ pF}$  to GND, and digital inputs at  $IOVDD$  or GND (unless otherwise noted)

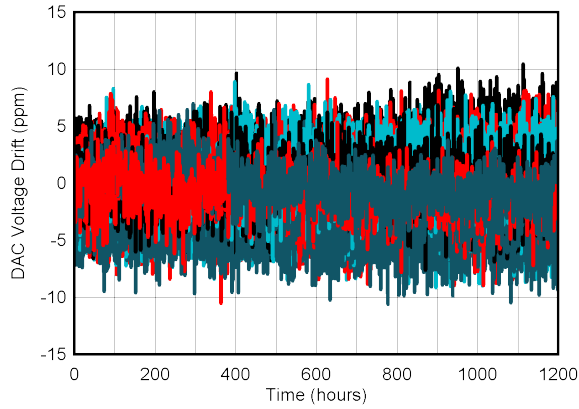

Ideal reference

图 6-33. DAC Output Voltage Long-Term Stability

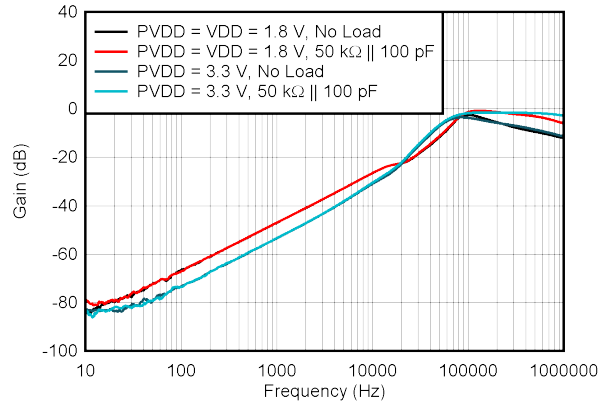

Internal Reference

图 6-34. DAC AC PSRR vs Frequency

## 6.9 Typical Characteristics: ADC

at  $T_A = 25^\circ\text{C}$ ,  $PVDD = VDD = IOVDD = 1.8\text{ V}$ , external or internal  $VREFIO = 1.25\text{ V}$ ,  $R_{LOAD} = 50\text{ k}\Omega$  to GND,  $C_{LOAD} = 100\text{ pF}$  to GND, and digital inputs at IOVDD or GND (unless otherwise noted)



图 6-35. ADC DNL vs Digital Input Code



图 6-36. ADC INL vs Digital Input Code

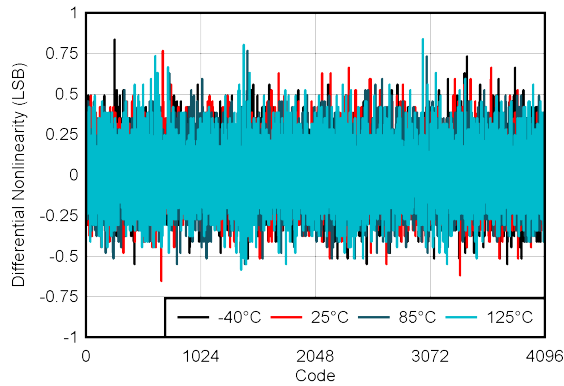

图 6-37. ADC DNL Range vs Temperature

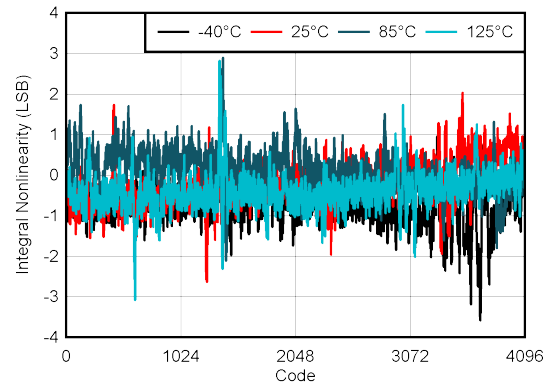

图 6-38. ADC INL Range vs Temperature

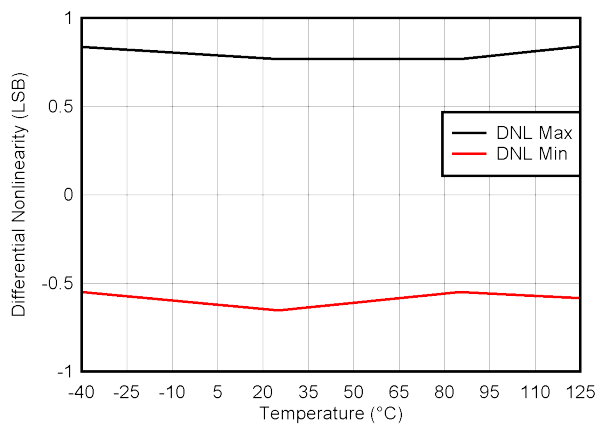

图 6-39. ADC Offset Error vs Temperature

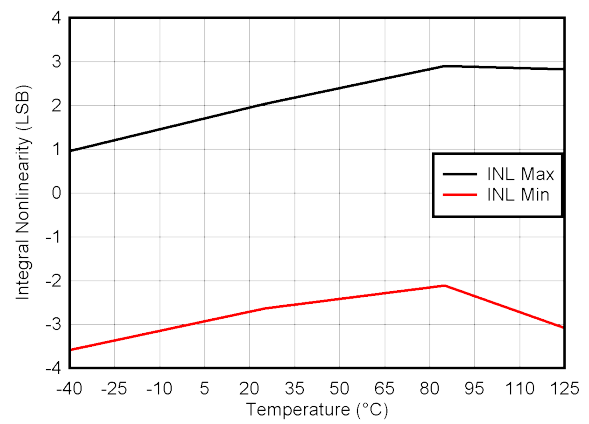

图 6-40. ADC Gain Error vs Temperature

### 6.10 Typical Characteristics: Reference

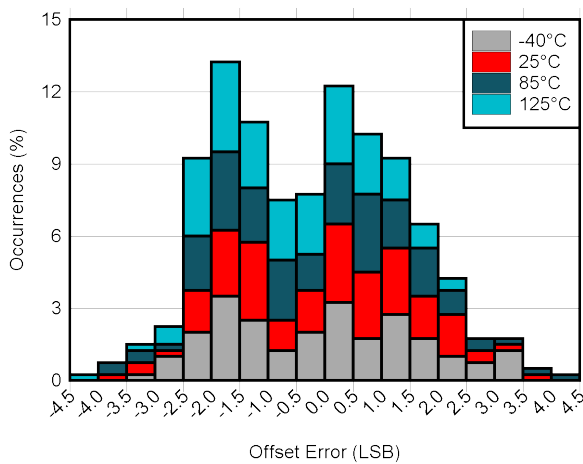
at  $T_A = 25^\circ\text{C}$ ,  $PVDD = IOVDD = 3.3\text{ V}$ , external or internal  $VREFIO = 1.25\text{ V}$ ,  $R_{LOAD} = 50\text{ k}\Omega$  to GND,  $C_{LOAD} = 100\text{ pF}$  to GND, and digital inputs at IOVDD or GND (unless otherwise noted)

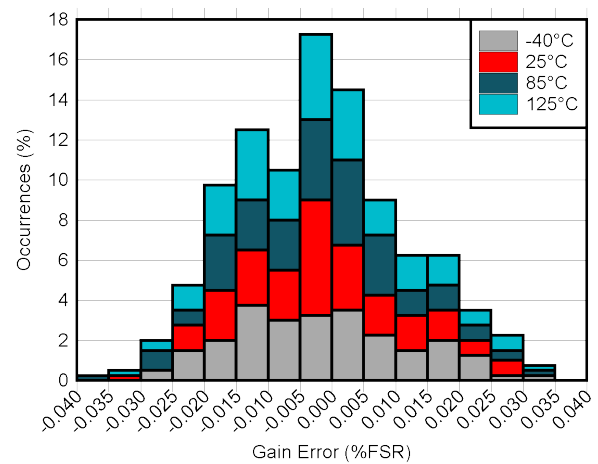

图 6-41. Reference Voltage Temperature Drift



图 6-42. Reference Voltage Temperature Drift

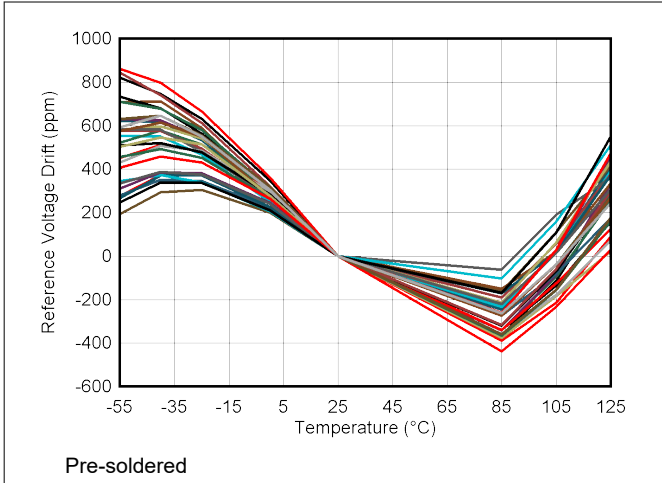

图 6-43. Multiple Temperature Cycle Hysteresis

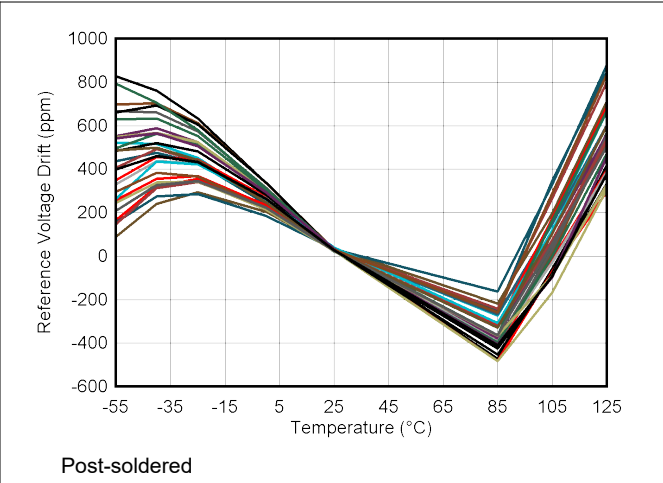

图 6-44. Multiple Temperature Cycle Hysteresis

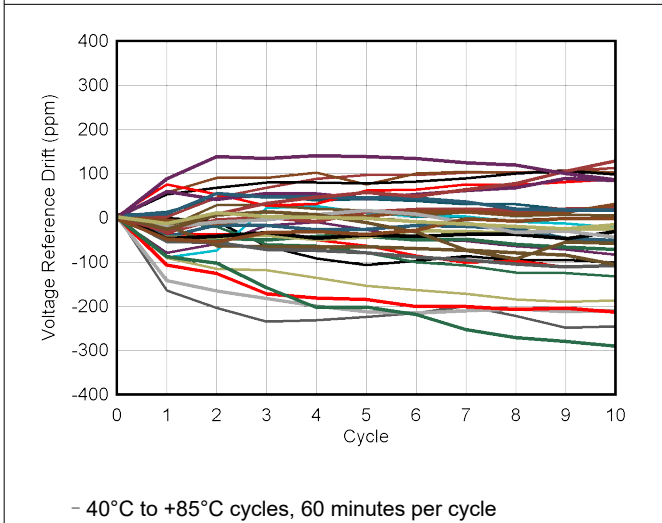

图 6-45. Ambient Temperature Change Settling

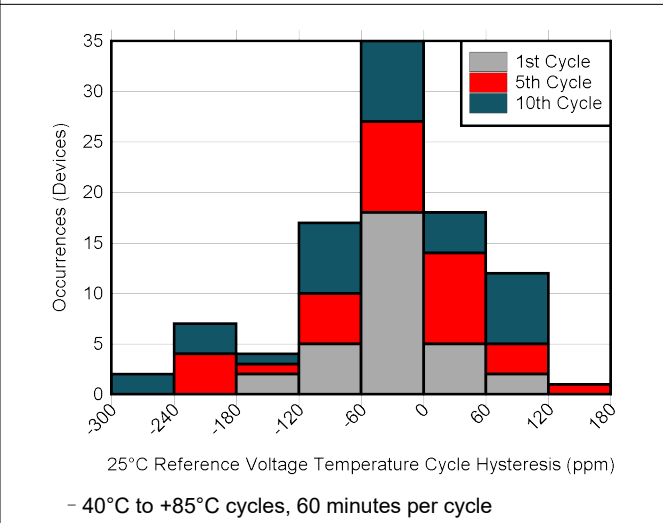

图 6-46. Reference Voltage Long-Term Stability

### 6.10 Typical Characteristics: Reference (continued)

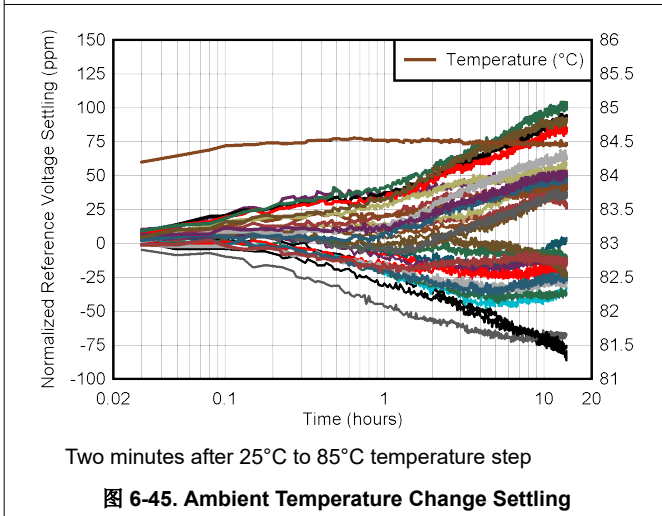
at  $T_A = 25^\circ\text{C}$ ,  $PVDD = IOVDD = 3.3\text{ V}$ , external or internal  $VREFIO = 1.25\text{ V}$ ,  $R_{LOAD} = 50\text{ k}\Omega$  to GND,  $C_{LOAD} = 100\text{ pF}$  to GND, and digital inputs at IOVDD or GND (unless otherwise noted)

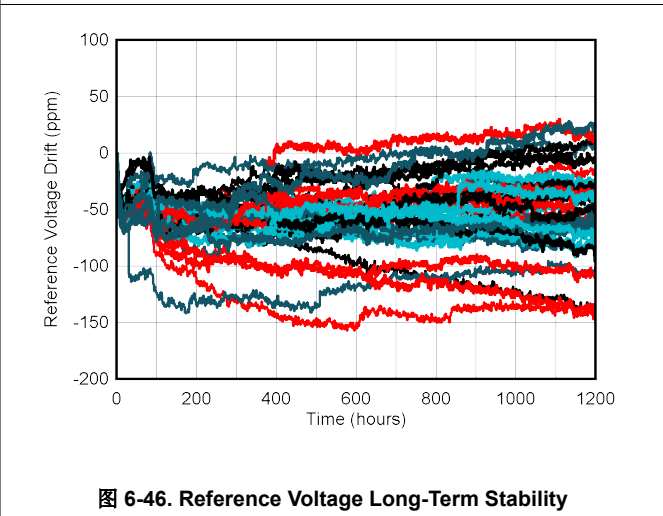

图 6-47. Reference Output Noise, 0.1 Hz to 10 Hz



图 6-48. Reference AC PSRR vs frequency

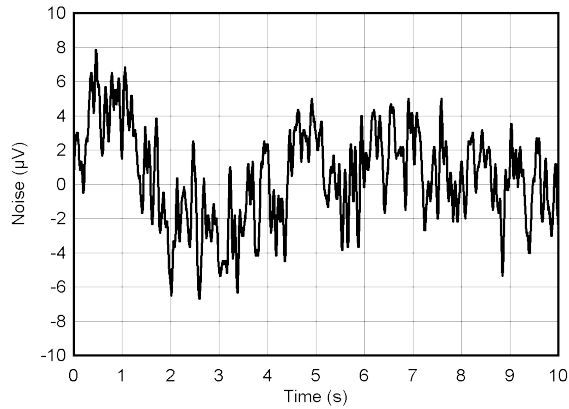

图 6-49. Reference Source and Sink Current Capability

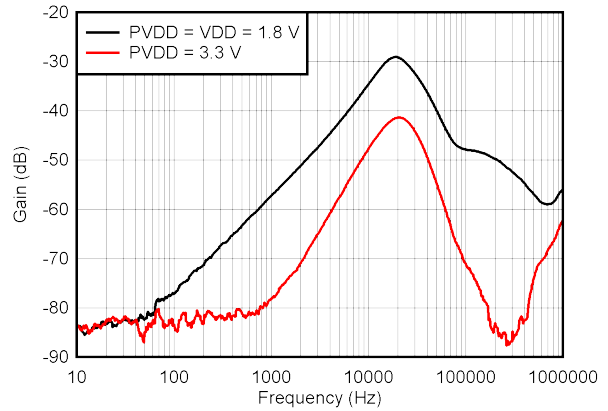

图 6-50. Initial Accuracy Distribution

### 6.11 Typical Characteristics: Power Supply

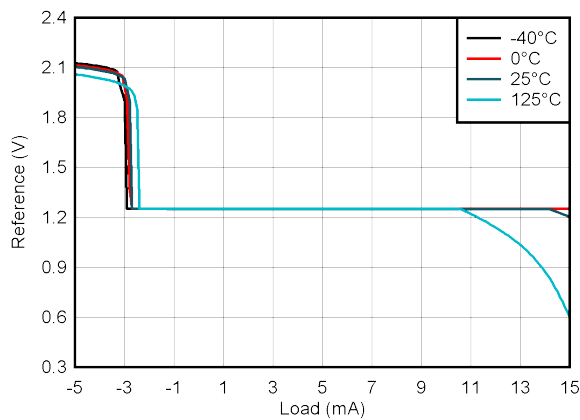
at  $T_A = 25^\circ\text{C}$ ,  $PVDD = IOVDD = 3.3\text{ V}$ , internal  $VREFIO$ ,  $R_{LOAD} = 50\text{ k}\Omega$  to GND,  $C_{LOAD} = 100\text{ pF}$  to GND, and digital inputs at  $IOVDD$  or GND (unless otherwise noted)

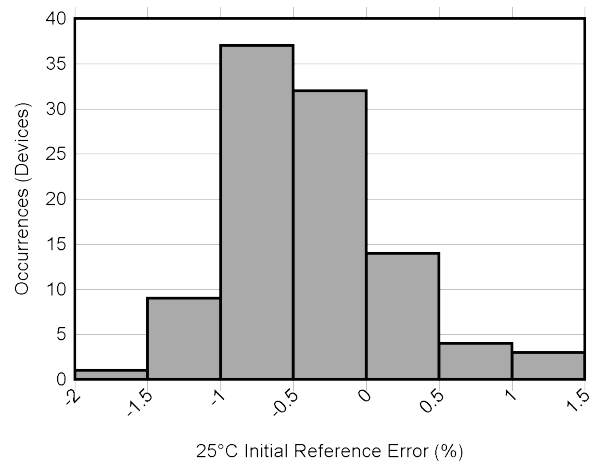
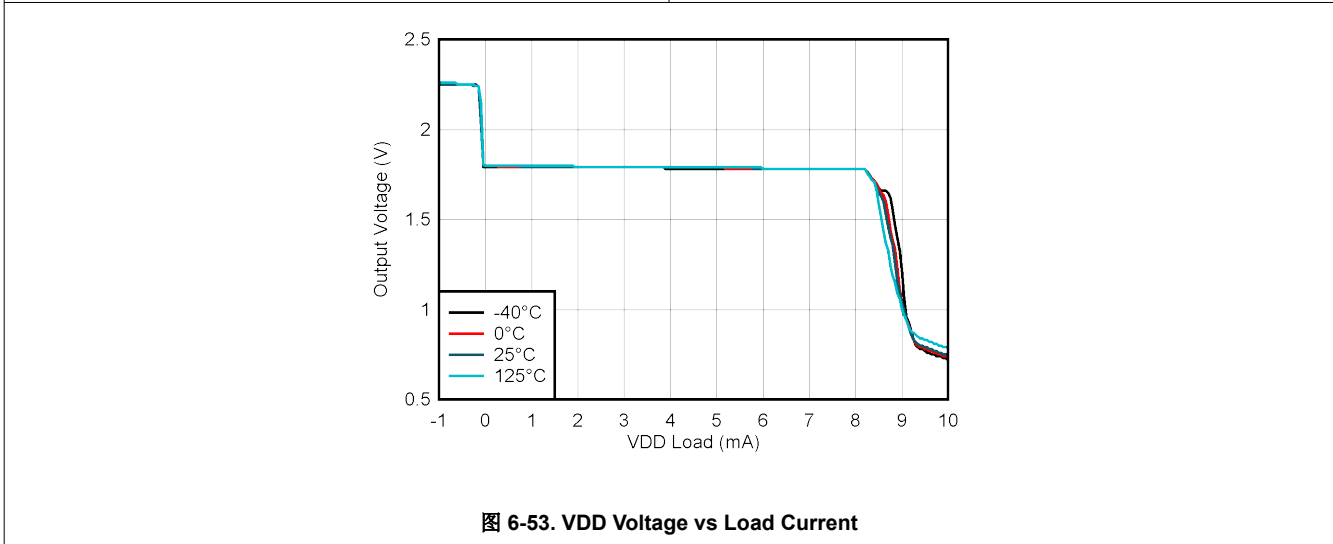
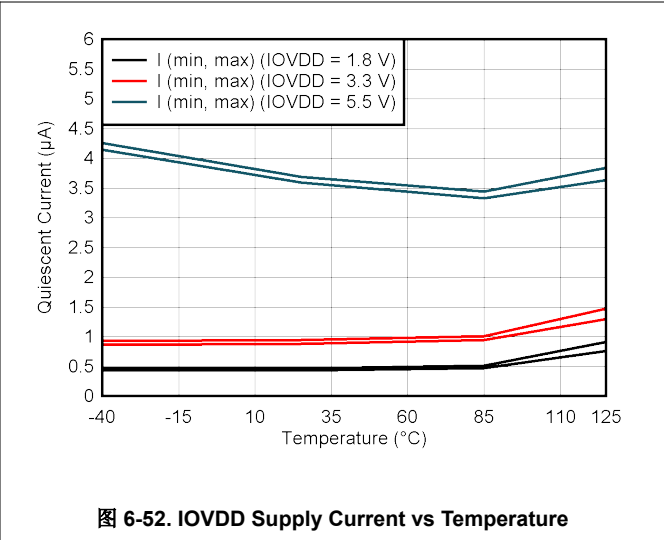
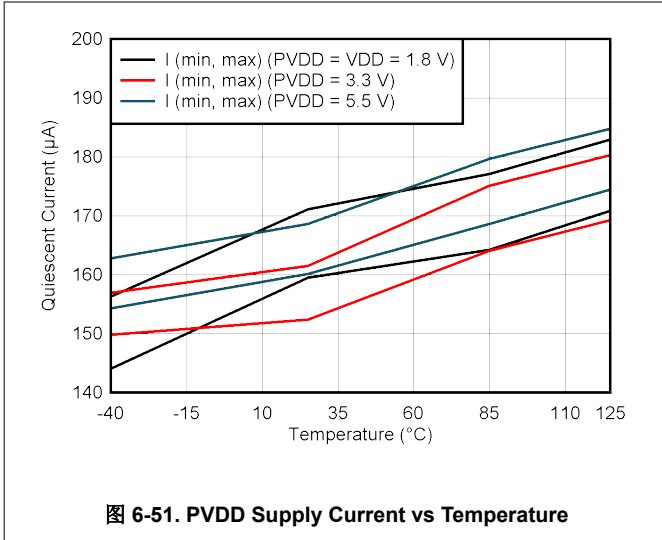

## 7 Detailed Description

### 7.1 Overview

The AFEx8101 feature a 16-bit (AFE88101) or 14-bit (AFE78101) string DAC with voltage output buffer. Both devices are capable of operating from supplies as low as 1.71 V at very low power, and are designed for 4-mA to 20-mA, loop-powered applications. The AFEx8101 have two different DAC output voltage ranges depending on supply voltage, and two other ranges depending on configuration. The DAC has calibration registers for setting gain and offset values for adjusting the DAC outputs. The DAC also has different output slewing modes that allow for a programmable linear slew and a sinusoidal shaped output slew.

The AFEx8101 also feature a 12-bit SAR ADC that can be multiplexed to measure different inputs, including external nodes and internal nodes for diagnostic measurements on the device. The ADC is capable of making direct-mode measurements with on-demand conversions or auto-mode measurements through continuous conversions using a channel sequencer with a multiplexer. The devices have optional alarm configurations with fault detection and alarm actions.

Device communication and programming are done through an SPI or through the UART break mode (UBM). With the SPI, a cyclic redundancy check (CRC) is implemented by default, which can be disabled. Additionally, communications can be monitored with a watchdog timer (WDT) that alerts the user if the device becomes unresponsive to periodic communication.

The AFEx8101 feature a 1.25-V, onboard precision voltage reference, and an integrated precision oscillator.

Throughout this data sheet, register and bit names are combined with a period to use the following format: <register\_name>.<bit\_name>. For example, the CLR bit in the DAC\_CFG register is labeled DAC\_CFG.CLR.

### 7.2 Functional Block Diagram

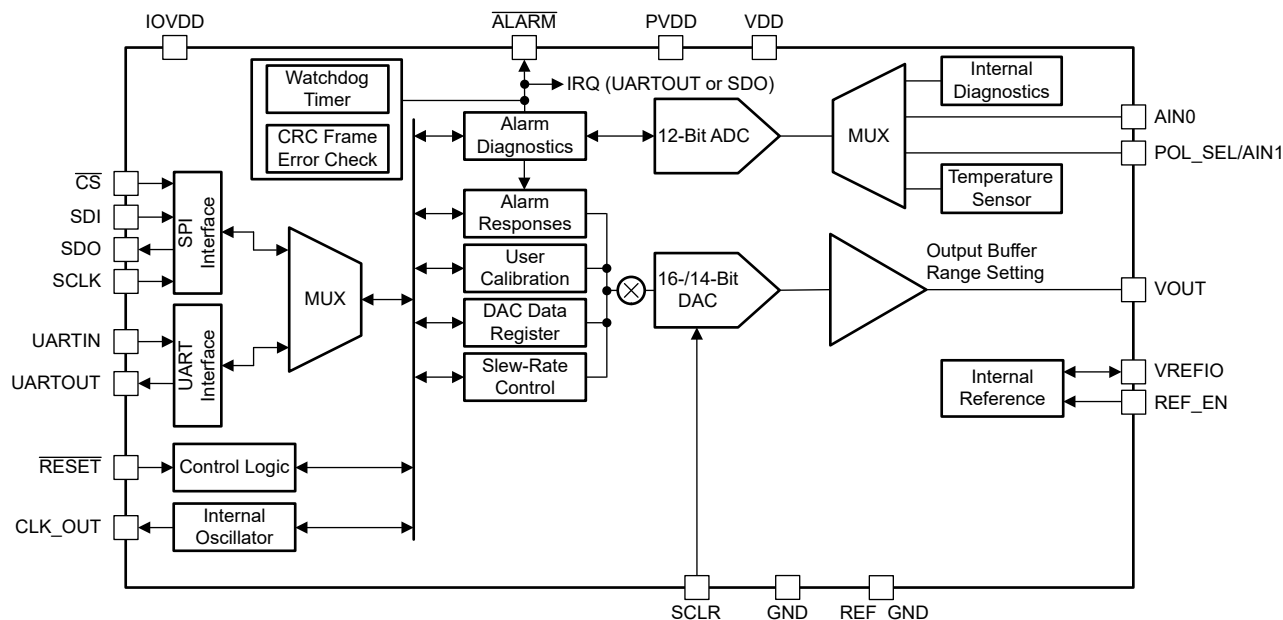

## 7.3 Feature Description

### 7.3.1 Digital-to-Analog Converter (DAC) Overview

The AFE8101 feature a 16-bit (AFE88101) or 14-bit (AFE78101) string DAC followed by an output voltage buffer. The DAC can be configured to support two low PVDD (0.15 V to 1.25 V and 0.2 V to 1 V), or high PVDD (0.3 V to 2.5 V and 0.4 V to 2 V) output ranges of operation depending on the PVDD supply voltage and the DAC\_CFG.RANGE bit in the device configuration register. Using a voltage-to-current converter stage, these output voltages can be used to control a 4 mA to 20 mA loop. The narrow range corresponds to a 4-mA to 20-mA range. The full range allows for currents under and over the 4-mA to 20-mA range.

The devices continuously monitor the PVDD supply to provide proper operation based on the DAC range setting. [表 7-1](#) shows the valid supply ranges and corresponding VOUT DAC voltage ranges for the AFE8101.

**表 7-1. VOUT DAC Voltage Ranges**

DAC CONFIGURATION	SUPPLY		DAC_CFG.RANGE	NAME	VOUT DAC VOLTAGE RANGE
	PVDD	VDD			
Invalid configuration	$0\text{ V} \leq \text{PVDD} < 1.71\text{ V}$	$0\text{ V} \leq \text{VDD} < 1.71\text{ V}$	NA	Alarm condition <sup>(1)</sup>	0.15 V or 1.25 V <sup>(2)</sup>
Low PVDD DAC range	$1.71\text{ V} \leq \text{PVDD} \leq 1.89\text{ V}$	$1.71\text{ V} \leq \text{VDD} \leq 1.89\text{ V}$	0	Full range	0.15 V to 1.25 V
			1	Narrow range	0.2 V to 1 V
Invalid configuration	$1.89\text{ V} < \text{PVDD} < 2.7\text{ V}$	$\text{VDD} > 1.89\text{ V}$	NA	Alarm condition <sup>(1)</sup>	0.15 V or 1.25 V <sup>(2)</sup>
High PVDD DAC range	$2.7\text{ V} \leq \text{PVDD} \leq 5.5\text{ V}$	VDD is internally generated	0	Full range	0.3 V to 2.5 V
			1	Narrow range	0.4 V to 2 V
Invalid configuration	$\text{PVDD} > 5.5\text{ V}$	$\text{VDD} > 1.89\text{ V}$	NA	Alarm condition <sup>(1)</sup>	0.3 V or 2.5 V <sup>(2)</sup>

(1) See [表 7-7](#) for details.

(2) See [图 7-12](#) for details.

If PVDD or VDD fall outside the specified threshold values associated with the supply configuration during operation, an alarm is generated and the DAC output is set according to the ALARM\_ACTION setting.

### 7.3.1.1 DAC Resistor String

图 7-1 shows that the resistor string structure consists of a series of resistors, each of value  $R$ . The code loaded to the DAC determines the node on the string at which the voltage is tapped off to be fed into the output amplifier. The voltage is tapped off by closing one of the switches connecting the string to the amplifier. The resistor string architecture has inherent monotonicity, voltage output, and low glitch.



图 7-1. DAC Resistor String

### 7.3.1.2 DAC Buffer Amplifier

The VOUT output pin is driven by the DAC output buffer amplifier. The output amplifier default settings are designed to drive capacitive loads as high as 100 pF without oscillation. The output buffer is able to source and sink 1 mA. The device implements short-circuit protection for momentary output shorts to ground and VDD supply. The source and sink short-circuit current thresholds are set to 5 mA.

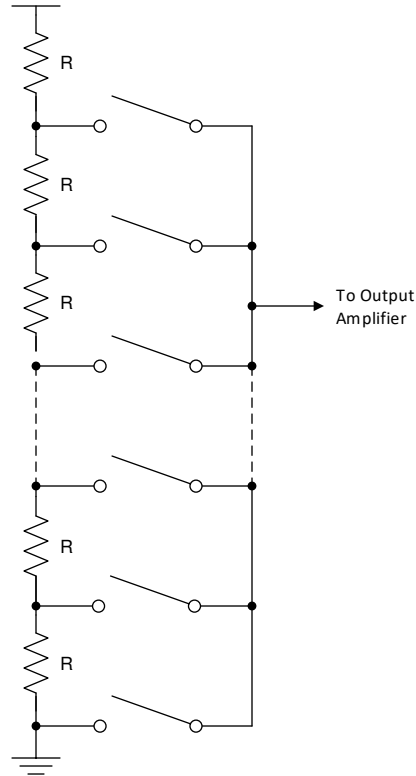

### 7.3.1.3 DAC Transfer Function

The following equation describes the DAC transfer function, which is the relationship between internal signal DAC\_CODE and output voltage VOUT:

$$V_{OUT} = \frac{DAC\_CODE}{2^N} \times FSR + V_{MIN} \quad (1)$$

where

- DAC\_CODE is an internal signal and the decimal equivalent of the gain and offset calibrated binary code loaded into the DAC\_DATA register. DAC\_CODE range = 0 to  $2^N - 1$ .
- N = DAC\_CODE resolution in bits (16 for the AFE88101 and 14 for the AFE78101).
- FSR = VOUT full-scale range for the selected output range in [表 7-2](#).
- $V_{MIN}$  = the lowest voltage for the selected DAC output range.

**表 7-2. FSR and  $V_{MIN}$  for all VOUT Ranges**

PVDD	DAC_CFG.RANGE	VOUT RANGE	FSR	$V_{MIN}$
1.8 V	0	0.15 V to 1.25 V	1.1 V	0.15 V
1.8 V	1	0.2 V to 1.0 V	0.8 V	0.2 V
$\geq 2.7$ V	0	0.3 V to 2.5 V	2.2 V	0.3 V
$\geq 2.7$ V	1	0.4 V to 2.0 V	1.6 V	0.4 V

The VOUT range for the DAC is determined by DAC\_CFG.RANGE bit when not in the CLEAR state. In the CLEAR state, the range is determined by DAC\_CFG.CLR\_RANGE bit.

### 7.3.1.4 DAC Gain and Offset Calibration

The AFEx8101 provide DAC gain and offset calibration capability to correct for end-point errors present in the system. Implement the gain and offset calibration using two registers, DAC\_GAIN.GAIN and DAC\_OFFSET.OFFSET. Update DAC\_DATA register after gain or offset codes are changed for the new values to take effect. The DAC\_GAIN can be programmed from 0.5 to 1.499985 using [方程式 2](#).

$$DAC\_GAIN = \frac{1}{2} + \frac{GAIN}{2^N} \quad (2)$$

where

- N = DAC\_GAIN resolution in bits: 16 for the AFE88101 and 14 for the AFE78101.
- GAIN is the decimal value of the DAC\_GAIN register setting.
- GAIN data are left justified; the last two LSBs in the DAC\_GAIN register are ignored for the AFE78101.

The example DAC\_GAIN settings for the AFE88101 are shown in [表 7-3](#).

**表 7-3. DAC\_GAIN Setting vs GAIN Code**

DAC_GAIN	GAIN (HEX)
0.5	0x0000
1.0	0x8000
1.499985	0xFFFF

The DAC\_OFFSET is stored in the DAC\_OFFSET register using 2's-complement encoding. The DAC\_OFFSET value can be programmed from  $-2^{(N-1)}$  to  $2^{(N-1)} - 1$  using [方程式 3](#).

$$\text{DAC\_OFFSET} = -\text{OFFSET}_{\text{MSB}} \times 2^{(N-1)} + \sum_{i=0}^{(N-2)} \text{OFFSET}_i \times 2^i \quad (3)$$

where

- N = DAC\_OFFSET resolution in bits: 16 for the AFE88101 and 14 for the AFE78101.
- $\text{OFFSET}_{\text{MSB}}$  = MSB bit of the DAC\_OFFSET register.
- $\text{OFFSET}_i$  = The rest of the bits of the DAC\_OFFSET register.
- $i$  = Position of the bit in the DAC\_OFFSET register.
- OFFSET data are left justified; the last two LSBs in the DAC\_OFFSET register are ignored for the device.

The most significant bit determines the sign of the number and is called the sign bit. The sign bit has the weight of  $-2^{(N-1)}$  as shown in [方程式 3](#).

The example DAC\_OFFSET settings for the AFE88101 are shown in [表 7-4](#).

**表 7-4. DAC\_OFFSET Setting vs OFFSET Code**

DAC_OFFSET	OFFSET (HEX)
32767	0x7FFF
1	0x0001
0	0x0000
-1	0xFFFF
-2	0xFFFE
-32768	0x8000

The following transfer function is applied to the DAC\_DATA.DATA based on the DAC\_GAIN and DAC\_OFFSET values:

$$\text{DAC\_CODE} = (\text{DATA} \times \text{DAC\_GAIN}) + \text{DAC\_OFFSET} \quad (4)$$

where

- DAC\_CODE is the internal signal applied to the DAC.
- DATA is the decimal value of the DAC\_DATA register.
- DAC\_GAIN and DAC\_OFFSET are the user calibration settings.
- DATA data are left justified; the last two LSBs in the DAC\_DATA register are ignored for the AFE78101.

Substituting DAC\_GAIN and DAC\_OFFSET in [方程式 4](#) with [方程式 2](#) and [方程式 3](#) results in:

$$\text{DAC\_CODE} = \left( \text{DATA} \times \left[ \frac{1}{2} + \frac{\text{GAIN}}{2^N} \right] \right) - \text{OFFSET}_{\text{MSB}} \times 2^{(N-1)} + \sum_{i=0}^{(N-2)} \text{OFFSET}_i \times 2^i \quad (5)$$

The multiplier is implemented using truncation instead of rounding. This truncation can cause a difference of one LSB if rounding is expected. [图 7-2](#) shows the DAC calibration path.



图 7-2. DAC Calibration Path

### 7.3.1.5 Programmable Slew Rate

The slew rate feature controls the rate at which the output voltage or current changes. This feature is disabled by default and is enabled by writing a logic 1 to the DAC\_CFG.SR\_EN bit. With the slew rate control feature disabled, the output changes smoothly at a rate limited by the output drive circuitry and the attached load.

With this feature enabled, the output does not slew directly between the two values. Instead, the output steps digitally at a rate defined by DAC\_CFG.SR\_STEP[2:0] and DAC\_CFG.SR\_CLK[2:0]. SR\_CLK defines the rate at which the digital slew updates. SR\_STEP defines the amount by which the output value changes at each update. 节 7.6.1 shows different settings for SR\_STEP and SR\_CLK.

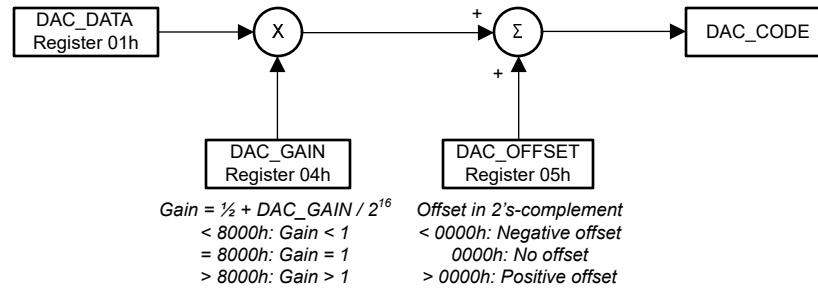
The time required for the output to slew is expressed as 方程式 6:

$$\text{Slew Time} = \frac{\text{Delta Code Change}}{\text{Slew Step} \times \text{Slew Clock Rate}} \quad (6)$$

where

- Slew Time is expressed in seconds
- Slew Step is controlled by DAC\_CFG.SR\_STEP
- Slew Clock Rate is controlled by DAC\_CFG.SR\_CLK

When the slew-rate control feature is enabled, the output changes at the programmed slew rate. This configuration results in a staircase formation at the output. If the clear code is asserted (see 节 7.3.1.6), the output slews to the DAC\_CLR\_CODE value at the programmed slew rate. When new DAC data are written, the output starts slewing to the new value at the slew rate determined by the current DAC code and the new DAC data. The update clock frequency for any given value is the same for all output ranges. The step size, however, varies across output ranges for a given value of step size because the LSB size is different for each output range.

Two slew-rate control modes are available: linear (default) and sinusoidal. 图 7-3 and 图 7-4 show the typical rising and falling DAC output waveforms, respectively.

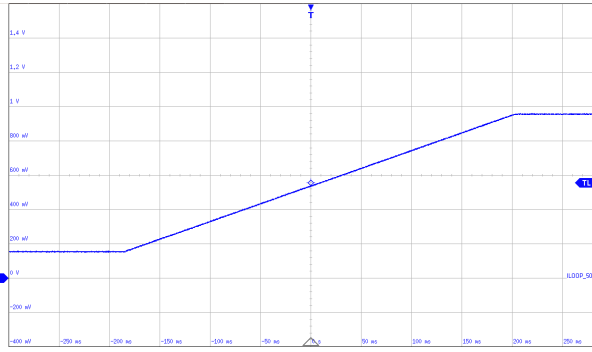

4 mA (0x0BA3) to 24 mA (0xF45D) measured on a 40-Ω shunt

图 7-3. Linear Slew Rate: Rising

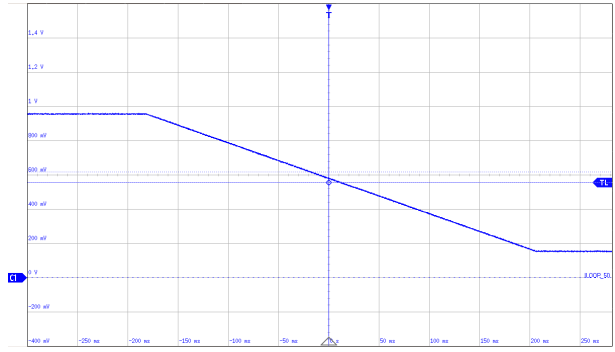

24 mA (0xF45D) to 4 mA (0x0BA3) measured on 40-Ω shunt

图 7-4. Linear Slew Rate: Falling

Sinusoidal mode enables fast DAC settling while improving analog rate of change characteristics. Sinusoidal mode is selected by the DAC\_CFG.SR\_MODE bit. 图 7-5 and 图 7-6 show the typical rising and falling DAC output waveforms with sinusoidal slew-rate control, respectively.

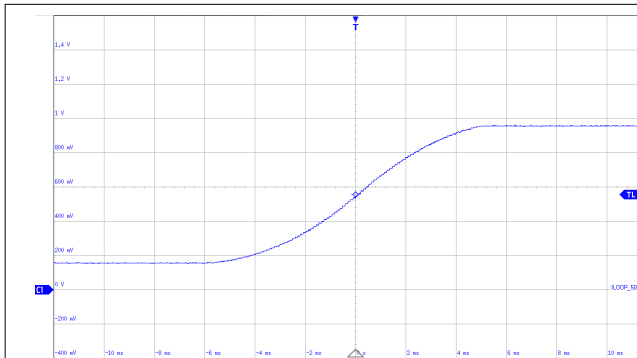

4 mA (0x0BA3) to 24 mA (0xF45D) measured on a 40-Ω shunt

**图 7-5. Sinusoidal Slew Rate: Rising**

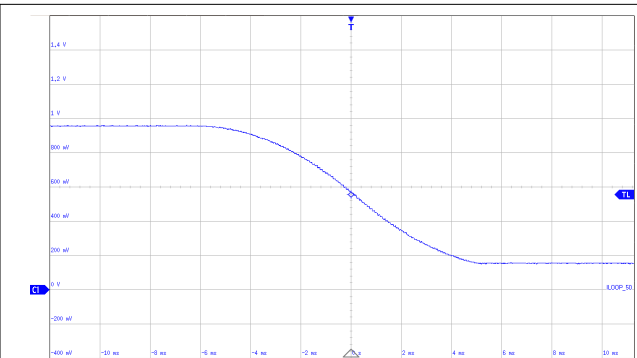

24 mA (0xF45D) to 4 mA (0x0BA3) measured on a 40-Ω shunt

**图 7-6. Sinusoidal Slew Rate: Falling**

If the slew-rate feature is disabled while the DAC is executing the slew-rate command, the slew-rate operation is aborted, and the DAC output goes to the target code.

### 7.3.1.6 DAC Register Structure and CLEAR State

The AFE88101 DAC has a 16-bit voltage output, and the AFE78101 DAC has a 14-bit voltage output. 表 7-1 shows four possible VOUT DAC output ranges. With a voltage-to-current converter stage, the narrow range corresponds to a 4-mA to 20-mA range. The full range allows for undercurrents and overcurrents from 3 mA to 25 mA, and is controlled by DAC\_CFG.RANGE.

The AFE8101 provide the option to quickly set the DAC output to the value set in the DAC\_CLR\_CODE register without writing to the DAC\_DATA register, referred to as the CLEAR state. Setting the DAC to CLEAR state also sets the DAC output range according to DAC\_CFG.CLR\_RANGE. For register details, see 表 7-15.

Transitioning from the DAC\_DATA to the DAC\_CLR\_CODE is synchronous to the clock. If slew mode is enabled, the output slews during the transition. 图 7-7 shows the full AFE8101 DAC\_DATA signal path. The devices synchronize the DAC\_DATA code to the internal clock, causing up to 2.5 internal clock cycles of latency (2  $\mu$ s) with respect to the rising edge of  $\overline{CS}$  or the end of a UBM command. Update DAC\_GAIN and DAC\_OFFSET values when DAC\_CFG.SR\_EN = 0 to avoid an IRQ pulse generated by SR\_BUSY.

Set the DAC to CLEAR state either by:

1. Setting DAC\_CFG.CLR.
2. Configuring the DAC to transition to the CLEAR state in response to an alarm condition.
3. Using the SDI pin in UBM or the SCLR pin in SPI mode as the CLEAR state input pin.

Method 1 is a direct command to the AFE8101 to set the DAC to CLEAR state. Set the DAC\_CFG.CLR bit to 1h to set the DAC to CLEAR state.

Method 2 is controlled by settings of ALARM\_ACT register. For details of conditions and other masks required to use this method, see 表 7-24 and 节 7.3.3.1.

Method 3 supports setting the DAC to CLEAR state without writing to the AFE8101. This pin-based DAC CLEAR state function is available in SPI mode on the SCLR pin, or in UBM on the SDI pin. The SCLR pin must be tied to GND in UBM. For details of connection options based on communication modes and pins used in each mode, see 节 7.5.1. Set the appropriate pin high to drive the DAC to CLEAR state.



图 7-7. DAC Data Path

### 7.3.2 Analog-to-Digital Converter (ADC) Overview

The AFE<sub>x</sub>8101 feature a monitoring system centered on a 12-bit successive approximation register (SAR) ADC and a highly flexible analog multiplexer. The monitoring system is capable of sensing up to two external inputs, as well as several internal device signals.

The ADC uses the VREFIO pin voltage as a reference. The ADC timing signals are derived from an on-chip oscillator. The conversion results are accessed through the device serial interface.

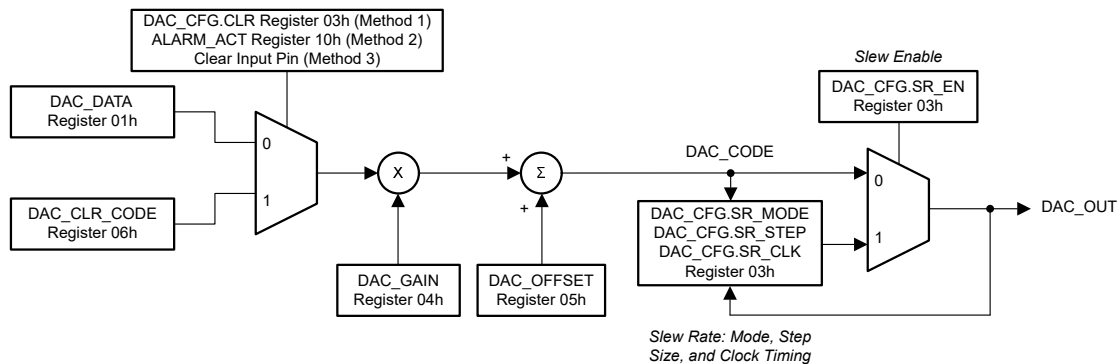
#### 7.3.2.1 ADC Operation

The device ADC supports direct-mode and auto-mode conversions. Both conversion modes use a custom channel sequencer to determine which of the input channels are converted by the ADC. The sequence order is fixed. The user selects the start channel and stop channel of the conversion sequence. The conversion method and channel sequence are specified in the ADC Configuration registers. The default conversion method is auto-mode. [图 7-8](#) shows the ADC conversion sequence.

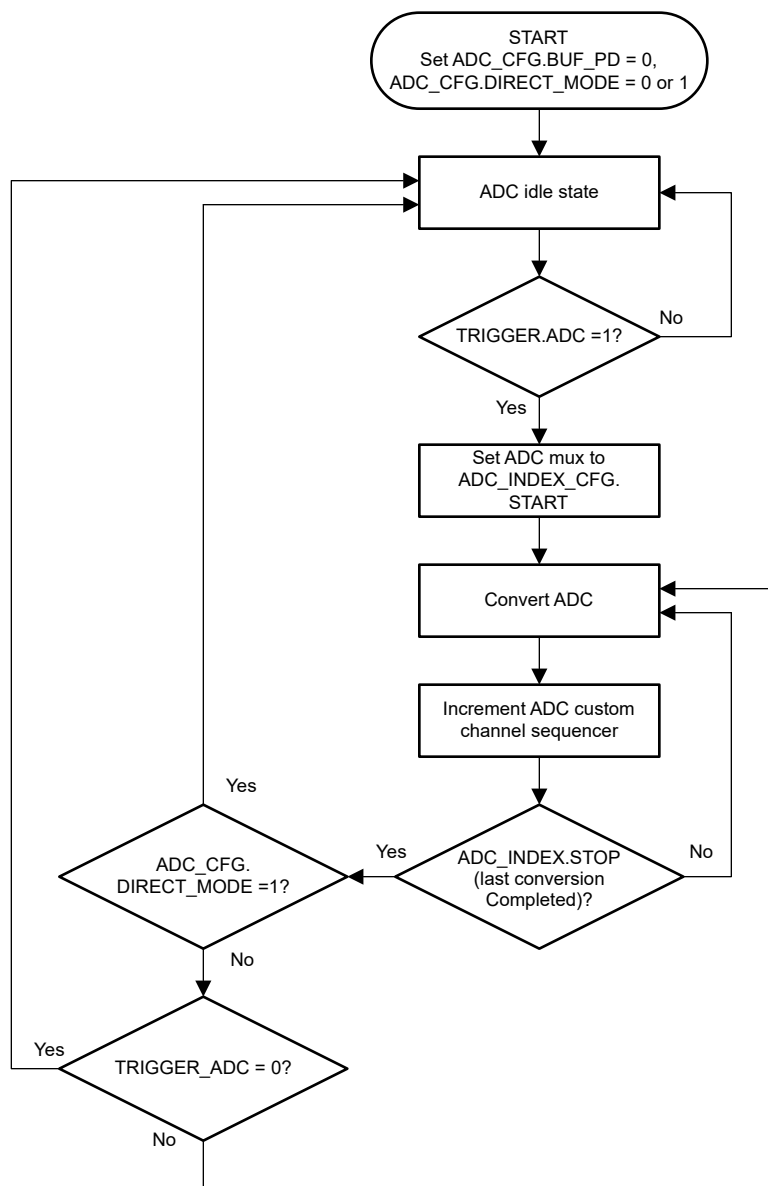

**图 7-8. ADC Conversion Sequence**

To use the ADC, first enable the ADC buffer by setting `ADC_CFG.BUF_PD = 0`. Then wait at least  $210 \mu\text{s}$  before setting the trigger using the `TRIGGER.ADC` bit. An internal delay is forced if the trigger signal is sent before the timer has expired. Make sure the ADC is not converting before setting the `ADC_CFG.BUF_PD = 1`. If `ADC_CFG.BUF_PD` is set to 1 while the ADC is still converting, the internal timer delays this command. When the timer expires, the enable signal for the ADC is cleared, and the current conversion finishes before powering down the ADC and the ADC Buffer.

A trigger signal must occur for the ADC to exit the idle state. The ADC trigger is generated through the `TRIGGER.ADC` bit. The ADC data registers have the latest available data. Accessing the data registers does not interfere with the conversion process, and thus provides continuous ADC operation.

In direct-mode conversion, the selected ADC input channels are converted on demand by issuing an ADC trigger signal. After the last enabled channel is converted, the ADC enters the idle state and waits for a new trigger. Read the results of the ADC conversion through the register map. Direct-mode conversion is typically used to gather the ADC data of any of the data channels. In direct-mode, use the `ADC_BUSY` bit to determine when a direct-mode conversion is complete and the ADC has returned to the idle state. Direct mode is set by writing `ADC_CFG.DIRECT_MODE = 1`.

In auto-mode conversion, the selected ADC input channels are converted continuously. The conversion cycle is initiated by issuing an ADC trigger. Upon completion of the first conversion sequence, another sequence is automatically started. Conversion of the selected channels occurs repeatedly until the auto-mode conversion is stopped by clearing the ADC trigger signal. Auto-mode conversion is not typically used to gather the ADC data. Instead, auto-mode conversions are used in combination with upper and lower ADC data thresholds to detect when the data has exceeded the programmable out-of-range alarm thresholds. Auto mode is set by writing `ADC_CFG.DIRECT_MODE = 0`.

Regardless of the selected conversion method, update the ADC configuration register only while the ADC is in the idle state. Do not change the ADC configuration bits while the ADC is converting channels. Before changing configuration bits, disable the ADC and verify that `GEN_STATUS.ADC_BUSY = 0`.



### 7.3.2.2 ADC Custom Channel Sequencer

The device uses a custom channel sequencer to control the multiplexer of the ADC. The ADC sequencer allows the user to specify which channels are converted. The sequencer consists of 16 indexed slots with programmable start and stop index fields to configure the start and stop conversion points.

In direct-mode conversion, the ADC converts from the start index to the stop index once and then stops. In auto-mode conversion, the ADC converts from the start to stop index repeatedly until the ADC is stopped. 图 7-9 shows the indexed custom channel sequence slots available in the device.



图 7-9. ADC MUX Control

表 7-5 lists the ADC input channel assignments for the sequencer.

表 7-5. Indexed Custom Channel Sequence

CCS POINTER	CHANNEL	CONV_RATE	RANGE
0	OFFSET	2560 Hz	VREF
1	AIN0	Programmable	Programmable
2	AIN1	Programmable	Programmable
3	TEMP	2560 Hz	VREF
4	SD0 (VREF)	2560 Hz	VREF
5	SD1 (PVDD)	2560 Hz	VREF
6	SD2 (VDD)	2560 Hz	VREF
7	SD3 (ZTAT)	2560 Hz	VREF
8	SD4 (VOUT)	2560 Hz	VREF when PVDD = 1.8 V 2 × VREF when PVDD ≥ 2.7 V
9-15	GND	2560 Hz	VREF

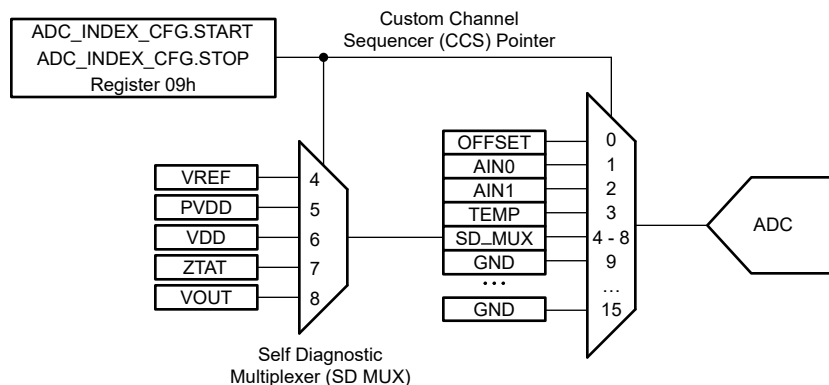
Use the ADC\_INDEX\_CFG register to select the channels. The order of the channels is fixed and shown in 表 7-5. Then, use ADC\_INDEX\_CFG.START and ADC\_INDEX\_CFG.STOP to select the range of indices to convert. If these two values are the same, then the ADC only converts a single channel. If the START and STOP values are different, then the ADC cycles through the corresponding indices. By default, all channels are configured to be converted; START = 0 and STOP = 8. If the AIN1 channel is not configured as an ADC input, then the result for this channel is 0x000. The minimum time for a conversion is still allotted to AIN1 if the channel is within the START and STOP range. If START is configured to be greater than STOP, then the device interprets the conversion sequence as if START = STOP.

In direct mode, each selected channel in the ADC\_INDEX\_CFG register is converted once per TRIGGER.ADC command. In auto mode, each channel selected in the ADC\_INDEX\_CFG register is converted once; after the last channel, the loop is repeated as long as the ADC is enabled. In auto mode, writing to TRIGGER.ADC = 1 starts the conversions. Writing TRIGGER.ADC = 0 disables the ADC after the current channel being converted

finishes. In direct mode, writing TRIGGER.ADC = 1 starts the sequence. When the sequence ends, then TRIGGER.ADC is self-cleared.

A minimum of 20 clock cycles is required to perform one conversion. The ADC clock is derived from the internal oscillator and divided by 16, which gives an ADC clock frequency of  $1.2288 \text{ MHz} / 16 = 76.8 \text{ kHz}$ , for a clock period =  $13.02 \mu\text{s}$ .

Each of the internal nodes has a fixed conversion rate. Pins AIN0 and AIN1 have programmable conversion rates (see also the ADC\_CFG register). Pins AIN0 and AIN1 also have a configurable range. If  $PVDD \geq 2.7 \text{ V}$ , then the input range can be either 0 V to 1.25 V or 0 V to 2.5 V, depending on the ADC\_CFG.RANGE bit. If  $PVDD = 1.8 \text{ V}$ , then only the 0 V to 1.25 V range is allowed. In this case, the ADC\_CFG.RANGE bit is prevented from being set.

If any ADC configuration bits are changed, the following sequence is recommended:

1. Disable the ADC
2. Wait for ADC\_BUSY to go low
3. Change the configuration
4. Restart the conversions

ADC\_BUSY can be monitored in the GEN\_STATUS register.

If the ADC is configured for direct mode (ADC\_CFG.DIRECT\_MODE = 1), then after setting the desired channels to convert, write a 1 to TRIGGER.ADC. This bit is self-cleared when the sequence is finished converting. This command converts all the selected channels once. To initiate another conversion of the channels, send another TRIGGER.ADC command.

### 7.3.2.3 ADC Synchronization

The trigger signal must be generated for the ADC to exit the idle state and start conversions. The ADC trigger is generated through the TRIGGER.ADC bit. The ADC data registers have the latest available data. Accessing the data registers does not interfere with the conversion process, and thus provides continuous ADC operation.

In direct-mode, use the GEN\_STATUS.ADC\_BUSY bit to determine when a direct-mode conversion is complete, and the ADC has returned to the idle state. Similarly, monitor the TRIGGER.ADC bit to see if the ADC has returned to the idle state.

### 7.3.2.4 ADC Offset Calibration

Channel 0 of the CCS pointer is named OFFSET. The OFFSET channel is used to calibrate and improve the ADC offset performance. Convert the OFFSET channel, and use the result as a calibration for the ADC offset in subsequent measurements.

This ADC channel samples  $VREF / 2$  and compares this result against 7FFh as a measure of the ADC offset. The data rate for the ADC measuring this channel is 2560 Hz. The ADC conversion for the OFFSET channel is subtracted from 7FFh and the resulting value is stored in ADC\_OFFSET (28h). The offset can be positive or negative; therefore, the value is stored in 2's complement notation.

With the subtraction from 7FFh, ADC\_OFFSET is the negative of the offset. This value is subtracted from conversions of the ADC by default. For direct measurements of the ADC, set ADC\_BYF.OFST\_BYF\_EN to 1 to enable the offset bypass.

### 7.3.2.5 External Monitoring Inputs

The AFE8101 have two analog inputs for external voltage sensing. Channels 1 and 2 for the CCS pointer are for external monitoring inputs that can be measured by pins AIN0 and AIN1, respectively. The input range for the analog inputs is configurable to either 0 V to 1.25 V or 0 V to 2.5 V. The analog inputs conversion values are stored in straight binary format in the ADC registers. The ADC resolution can be computed by [方程式 7](#):

$$1 \text{ LSB} = \frac{V_{\text{RANGE}}}{2^{12}} \quad (7)$$

where

- $V_{\text{RANGE}} = 2.5 \text{ V}$  for the 0-V to 2.5-V input range or  $1.25 \text{ V}$  for the 0-V to 1.25-V input range.

[图 7-10](#) 和 [表 7-6](#) detail the transfer characteristics.

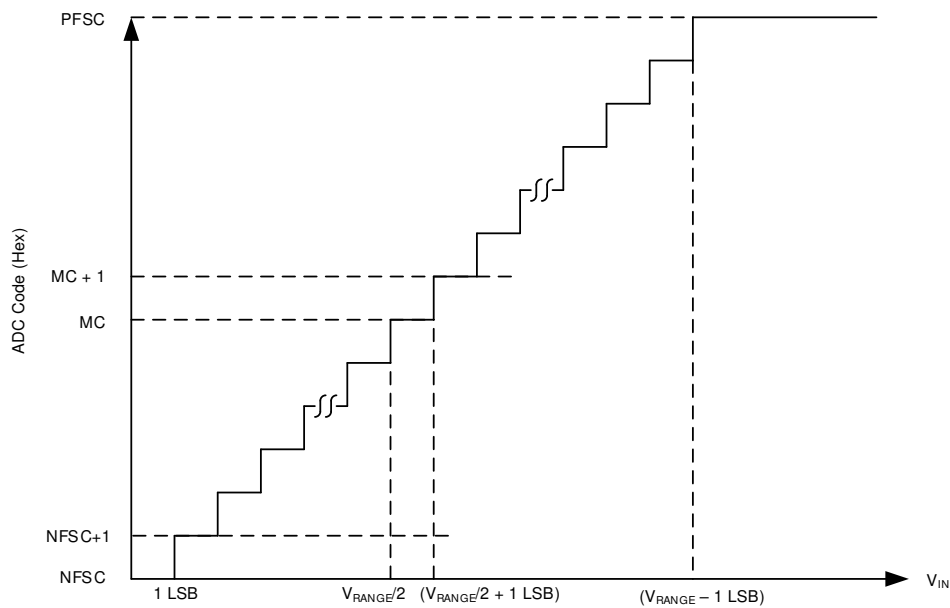

**图 7-10. ADC Transfer Characteristics**

**表 7-6. Transfer Characteristics**

INPUT VOLTAGE	CODE	DESCRIPTION	IDEAL OUTPUT CODE
$\leq 1 \text{ LSB}$	NFSC	Negative full-scale code	000
1 LSB to 2 LSB	NFSC + 1	Negative full-scale code plus 1	001
$(V_{\text{RANGE}} / 2)$ to $(V_{\text{RANGE}} / 2) + 1 \text{ LSB}$	MC	Midcode	800
$(V_{\text{RANGE}} / 2) + 1 \text{ LSB}$ to $(V_{\text{RANGE}} / 2) + 2 \text{ LSB}$	MC + 1	Midcode plus 1	801
$\geq V_{\text{RANGE}} - 1 \text{ LSB}$	PFSC	Positive full-scale code	FFF

For these external monitoring inputs, the ADC is configurable for both data rate and voltage range. The data rate is set to either 640 Hz, 1280 Hz, 2560 Hz, or 3840 Hz with the ADC\_CFG.CONV\_RATE bits. The range of the ADC measurement is set with the ADC\_CFG.AIN\_RANGE bit. The ADC range is  $2 \times V_{\text{REF}}$  when the bit = 0; the ADC range is  $V_{\text{REF}}$  when the bit = 1. ADC\_CFG.AIN\_RANGE only controls the range if  $PV_{\text{DD}} > 2.7 \text{ V}$ . When  $PV_{\text{DD}} = 1.8 \text{ V}$ , the range is  $V_{\text{REF}}$  regardless of the setting.

When the ADC conversion is completed for AIN0 and AIN1, the resulting ADC data are stored in the ADC\_AIN0.DATA and ADC\_AIN1.DATA bits at 24h and 25h of the register map.

If the external monitoring inputs are not used, connect the AIN0 and AIN1 pins to GND through a  $1\text{-k}\Omega$  resistor.

### 7.3.2.6 Temperature Sensor

Channel 3 of the CCS is used to measure the die temperature of the device. The ADC measures an internal temperature sensor that measures a voltage complementary to the absolute temperature (CTAT). This CTAT voltage has a negative temperature coefficient. The ADC converts this voltage at a data rate of 2560 Hz. When the ADC conversion is completed, the data are found in the ADC\_TEMP.DATA bits (address 26h).

The relationship between the ambient temperature and the ADC code is shown in [方程式 8](#):

$$\text{ADC Code} = 2681 - 11 \times T_A(^{\circ}\text{C}) \quad (8)$$

### 7.3.2.7 Self-Diagnostic Multiplexer

In addition to the ADC offset, the two external monitoring inputs, and the temperature sensor, the ADC of the AFEx8101 has five other internal inputs to monitor the reference voltage, the power supplies, a static voltage, and the DAC output. These five voltages measurements are part of the self-diagnostic multiplexer (SD0 to SD4) measurements of the ADC, and are reported in the ADC\_SD\_MUX register at 27h; see also [节 7.6](#).

Channel 4 (SD0) measures the reference voltage of the device. The ADC measures the reference voltage through a resistor divider (divide by two). Be aware that all ADC measurements are a function of the reference; using SD0 to measure the reference is not revealing as a diagnostic measurement. The data rate for this conversion is 2560 Hz and the range of the ADC is set to VREF.

Channel 5 (SD1) measures the PVDD power supply of the device. The ADC measures the PVDD voltage through a resistor divider (divide by six). The data rate for this conversion is 2560 Hz and the range of the ADC is set to VREF.

Channel 6 (SD2) measures the VDD power supply of the device. When channel 6 is selected, the ADC measures the VDD voltage through a resistor divider (divide by 2). The data rate for this conversion is 2560 Hz and the range of the ADC is set to VREF.

Channel 7 (SD3) is a ZTAT (zero temperature coefficient) voltage. This internal voltage is nominally 0.6 V with a low temperature drift and does not depend on the reference voltage. An ADC measurement of ZTAT voltage can be useful to determine the state of the reference voltage. The data rate for this conversion is 2560 Hz and the range of the ADC is set to VREF.

Channel 8 (SD4) measures the VOUT of the DAC. The ADC measures the VOUT voltage through a resistor divider (divide by two). The data rate for this conversion is 2560 Hz.

The input range for the DAC voltage monitoring input is scaled from either 0-V to 2.5-V or 0-V to 1.25-V, depending on PVDD voltage. As soon as the PVDD voltage exceeds 2.7 V, the input range for the DAC voltage monitoring automatically switches to the 0-V to 2.5-V range. The DAC voltage conversion values are stored in straight-binary format in the ADC registers. The ADC resolution for these channels is computed by [方程式 7](#).

### 7.3.2.8 ADC Bypass

To test the offset, modify the ADC data path by programming the bypass data register, ADC\_BYP.DATA (2Eh). This read/write register is used in two different ways.

First, this bypass data register is used as a substitute for the ADC\_OFFSET by setting the ADC\_BYP.OFST\_BYP\_EN to 1.

Second, the ADC\_BYP.DATA is used as the readback register for the data for the different settings of the custom channel sequencer. The data are replaced by setting the ADC\_BYP.DATA\_BYP\_EN bit. When this bit is set to 1, the ADC conversion is bypassed, and the value of ADC\_BYP.DATA is used in the readback channel. This setting is used to test the alarm settings of the ADC.

When the ADC bypass is unused, set the ADC\_BYP.DATA to 000h.

图 7-11 shows the ADC bypass data flow.



图 7-11. ADC Bypass Data Flow

### 7.3.3 Programmable Out-of-Range Alarms

The AFE8101 are capable of continuously analyzing the supplies, external ADC inputs, DAC output voltage, reference, internal temperature, and other internal signals for normal operation.

Normal operation for the conversion results is established through the lower- and upper-threshold registers. When any of the monitored inputs are out of the specified range, the corresponding alarm bit in the alarm status registers is set.

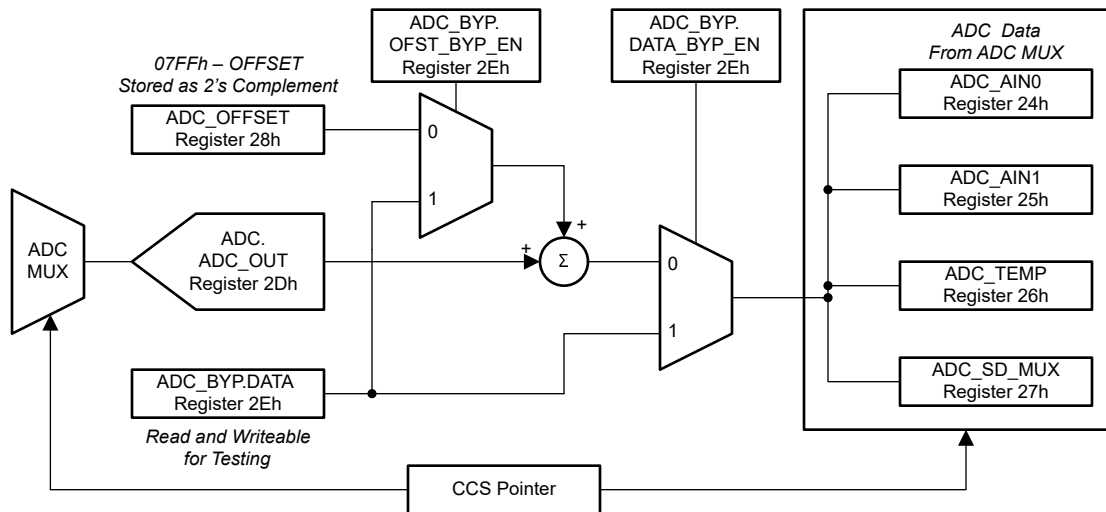
The alarm bits in the alarm status registers are latched. The alarm bits are referred to as being latched because the alarm bits remain set until read by software. This design makes sure that out-of-limit events cannot be missed if the software is polling the device periodically. All bits are cleared when reading the alarm status registers, and all bits are reasserted if the out-of limit condition still exists on the next monitoring cycle.

All of the alarms can be set to activate the  $\overline{\text{ALARM}}$  pin. The  $\overline{\text{ALARM}}$  pin works as an interrupt to the host so that the host can query the alarm status registers to determine the alarm source. Any alarm event activates the pin as long as the alarm is not masked in the ALARM\_STATUS\_MASK register. When an alarm event is masked, the occurrence of the event sets the corresponding status bit in the alarm status registers, but does not activate the  $\overline{\text{ALARM}}$  pin.

In addition, 节 7.3.3.1 describes how the alarm action can be individually configured for each alarm. When the alarm event is cleared, the DAC is reloaded with the contents of the DAC active registers, which allows the DAC outputs to return to the previous operating point without any additional commands.

### 7.3.3.1 Alarm Action Configuration Register

The AFE<sub>x</sub>8101 implements an alarm action configuration register (ALARM\_ACT, 表 7-24). Writing to this register selects the action that the device automatically takes in case of a specific alarm condition. The ALARM\_ACT register determines how the main DAC responds to an alarm event from conversion on self-diagnostics channels, AIN0, AIN1, and TEMP, as well as a CRC and WDT fault, a VREF fault, a TEMP\_HI fault, and a TEMP\_LO fault. Only these faults can cause a response by the DAC. Other alarm status events can trigger the ALARM pin. There are four options for alarm action. In case different settings are chosen for different alarm conditions, the following (low-to-high) priority is considered when taking action:

- 0. → No action
- 1. → DAC CLEAR state
- 2. → VOUT alarm voltage
- 3. → VOUT Hi-Z

If the alarm event occurs and option 1 is selected, then the DAC is forced to the clear code and clear range. This operation is done by controlling the input code to the DAC and the range of the DAC.

If the alarm event occurs and option 2 is selected, then VOUT is forced to the alarm voltage. The alarm voltage is controlled by either pin or register bit. If SPECIAL\_CFG.AIN1\_ENB = 0, then the AIN1 pin controls alarm polarity. Also, register bit SPECIAL\_CFG.ALMV\_POL can be used. If either of these signals = 1, then the alarm voltage is high; otherwise, the alarm voltage is low. The SPECIAL\_CFG register is only reset with POR, so the user setting remains intact through hardware or software resets.

If the alarm event occurs and option 3 is selected, then the VOUT buffer is put into Hi-Z.

If multiple events occur, then the highest setting takes precedence. Option 3 has the highest priority.

### 7.3.3.2 Alarm Voltage Generator

图 7-12 shows that the alarm voltage is generated independently from the DAC output voltage. The alarm polarity control logic selects the output level of the alarm voltage generator. The alarm action control logic selects between the DAC output and alarm voltage generator output voltages. The alarm action control logic also controls the output buffer Hi-Z switch.



图 7-12. Alarm Voltage Generator Architecture

During normal operation, the expected VOUT voltage depends on the DAC\_CODE. The ADC thresholds for the SD4 (VOUT) diagnostic channel are set around the programmed DAC\_CODE. During the alarm condition, if the alarm action changes the VOUT voltage to the alarm voltage, or switches the VOUT buffer into Hi-Z mode, the VOUT voltage no longer depends on the DAC\_CODE. In this case, the SD4 (VOUT) diagnostic channel also reports the alarm. To clear this alarm, as long as all other alarm conditions are cleared, set the alarm action to either no action or to the DAC clear code. Applying either alarm action sets the VOUT voltage within the expected ADC thresholds and clears the alarm after the next ADC measurement of the SD4 (VOUT) channel.

Give special consideration to the alarm logic during the transient events. When the new DAC\_CODE goes beyond the SD4 (VOUT) alarm thresholds with the ADC monitoring the SD4 (VOUT) input in auto mode, the ADC conversion can occur while VOUT settles to a new value. This conversion can trigger a false alarm. There are two ways to prevent this false alarm:

1. Use direct mode and allow VOUT to settle before triggering the next ADC conversion.
2. Set ADC\_CFG.FLT\_CNT > 0. With this configuration, a single error in SD4 or any other measurement does not cause an alarm condition to be asserted.

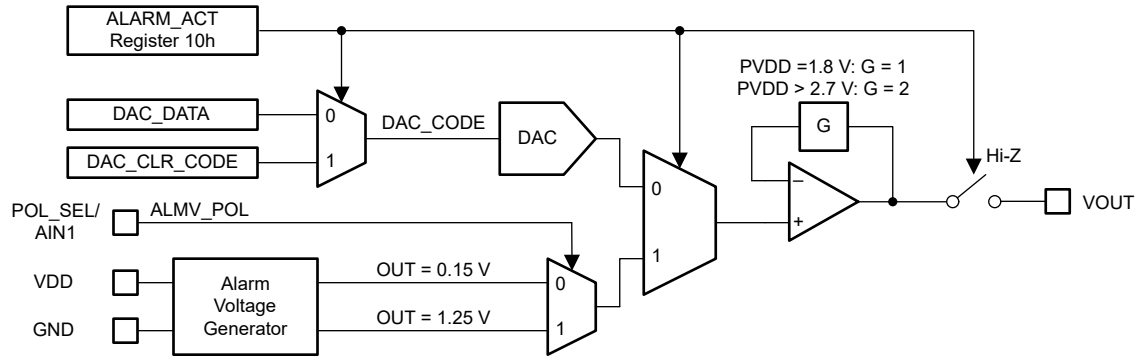
### 7.3.3.3 Temperature Sensor Alarm Function

The AFEx8101 continuously monitor the internal die temperature. In addition to the ADC measurement, the temperature sensor triggers a comparator to show a thermal warning and a thermal error. A thermal warning alarm is set when the temperature exceeds 85°C. Additionally, a thermal error alarm is set when the die temperature exceeds 130°C.

The thermal warning and thermal error alarms can be configured to set the  $\overline{\text{ALARM}}$  pin and are indicated in the ALARM\_STATUS register. These alarms can be masked with the ALARM\_MASK register and also be configured to control the DAC output with the ALARM\_ACT register.

### 7.3.3.4 Internal Reference Alarm Function

The devices provide out-of-range detection for the reference voltage. When the reference voltage exceeds  $\pm 5\%$  of the nominal value, the reference alarm flag (VREF\_FLT bit) is set. Make sure that a reference alarm condition has not been issued by the device before powering up the DAC output.

### 7.3.3.5 ADC Alarm Function

The AFEx8101 provide independent out-of-range detection for each of the ADC inputs. 图 7-13 shows the out-of-range detection block. When the measurement is out of range, the corresponding alarm bit is set to flag the out-of-range condition.



图 7-13. ADC Out-of-Range Alarm

An alarm event is only registered when the monitored signal is out of range for  $N$  number of consecutive conversions, where  $N$  is configured in the ADC\_CFG.FLT\_CNT false alarm register settings. If the monitored signal returns to the normal range before  $N$  consecutive conversions, an alarm event is not issued.

If an ADC input signal is out of range and the alarm is enabled, then the corresponding alarm bit is set to 1. However, the alarm condition is cleared only when the conversion result returns to a value less than the high-limit register setting and greater than the low-limit register setting by the number of codes specified by the hysteresis setting (see 图 7-14). The hysteresis is a programmable value between 0 LSB to 127 LSB in the ADC\_CFG.HYST register.

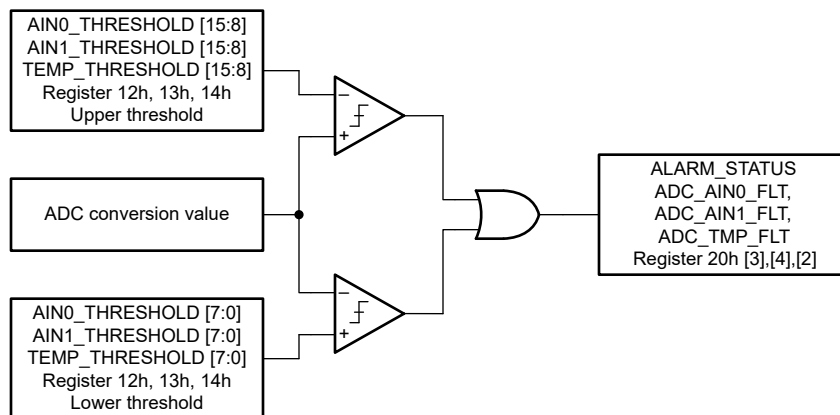

图 7-14. ADC Alarm Hysteresis



### 7.3.3.6 Fault Detection

There are two fields within the ADC\_CFG register: FLT\_CNT and HYST. These fields are applied to the assertion and deassertion of alarm conditions for all the ADC channels.

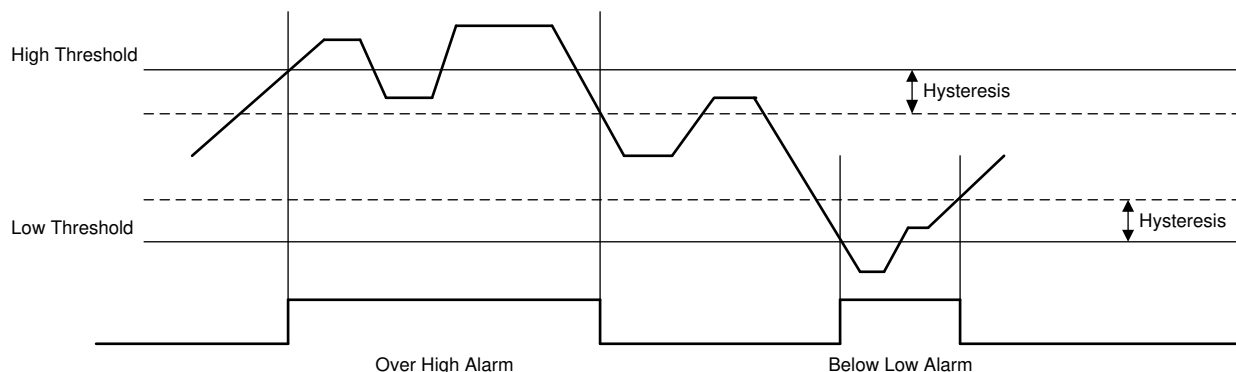
ADC\_CFG.FLT\_CNT determines the number of consecutive failures needed to trip an alarm condition. For example, if ADC\_CFG.FLT\_CNT is set for three counts, then three consecutive conversions must be outside of the thresholds. Each failure counts towards the FLT\_CNT limit even if the failures alternate between high threshold and low threshold.

ADC\_CFG.HYST sets the hysteresis used by the alarm-detection circuit. After an alarm is triggered, the hysteresis is applied before the alarm condition is released. In the case of the high threshold, the hysteresis is subtracted from the threshold value. In the case of the low threshold limit, the hysteresis is added to the threshold value.

Channels AIN0, AIN1, and TEMP have high and low thresholds associated with them. If a conversion value falls outside of these limits (that is, if TEMP < low threshold or TEMP > high threshold), an alarm condition for that channel is set. The alarms are disabled by setting 0x000 for the low threshold and 0xFFF for the high threshold, respectively. These alarms are disabled by default. Because the configuration fields for the thresholds are only eight bits wide, the four LSBs are hardcoded for each threshold. The high thresholds four LSBs are hardcoded to 0xF, and the low thresholds four LSBs are hardcoded to 0x0.

All the self diagnostic (SD) channels have fixed thresholds, except SD4, which measures the VOUT of the main DAC. The threshold for SD4 tracks the VOUT with respect to the DAC code. 表 7-7 shows the calculations used to determine the high and low ADC thresholds for each SD channel. The limits in the two right-most columns are determined by the threshold columns to the left and given some margin. The four LSBs are assigned as described previously.

**表 7-7. Self Diagnostic (SD) Alarm ADC Thresholds**

SD	ADC INPUT	ACCEPTED LOW VALUE	ACCEPTED HIGH VALUE	LOW THRESHOLD	HIGH THRESHOLD	ADC LOW (HEX)	ADC HIGH (HEX)
SD0	VREF/2	VREF/2 - 9% - 25 mV	VREF/2 + 9% + 25 mV	0.54375 V	0.70625 V	0x6D0	0x92F
SD1	PVDD/6	1.65/6 - 25 mV	6/6 + 25 mV	0.25 V	1.025 V	0x310	0xD3F
SD2	VDD/2	1.6/2 - 25 mV	2/2 + 25 mV	0.775 V	1.025 V	0x9C0	0xD3F
SD3	0.6 V	0.6 V - 9% - 25 mV	0.6 V + 9% + 25 mV	0.521 V	0.679 V	0x690	0x8CF
SD4	VOUT/2	VOUT/2 - 6 mV	VOUT/2 + 6 mV	VOUT - 12 mV	VOUT + 12 mV	Expected - 0x040	Expected + 0x040

The alarm threshold for the SD4 input depends on the expected ADC measurement based on the DAC code. The threshold is different for each DAC range and is adjusted accordingly. 方程式 9 shows the expected ADC code for RANGE = 0, and 方程式 10 shows the expected ADC code for RANGE = 1.

$$\text{ADC Expected Code: RANGE 0} = \frac{(\text{DAC\_CODE}[\text{MSB:MSB} - 11] \times 113 \div 128) + 492}{2} \quad (9)$$

$$\text{ADC Expected Code: RANGE 1} = \frac{(\text{DAC\_CODE}[\text{MSB:MSB} - 11] \times 82 \div 128) + 655}{2} \quad (10)$$

### 7.3.4 IRQ

The devices include an interrupt request (IRQ) to communicate the occurrence of a variety of events to the host controller. The IRQ block initiates interrupts that are reported internally in a status register, externally on the IRQ pin if the function is enabled, or on the ALARM pin if the condition is from the ALARM\_STATUS register. 图 7-15 shows the IRQ block diagram.



图 7-15. IRQ Block Diagram

There are two registers that can generate interrupts: GEN\_STATUS and ALARM\_STATUS. Each of these registers has a corresponding STATUS\_MASK register. The mask register controls which of the events trigger an interrupt. Writing a 1 in the mask register masks, or disables, the event from triggering an interrupt. Writing a 0 in the mask register allows the event to trigger an IRQ. All bits are masked by default. Some status bits are sticky. Reading the corresponding register clears a sticky bit, unless the condition still exists.

The IRQ is configured through CONFIG.IRQ\_LVL to be edge- or level-sensitive. Set this bit to logic 1 to enable level-sensitive functionality (default). In edge-sensitive mode, the IRQ signal is a synchronous pulse, one internal clock period wide (813 ns). In level-sensitive mode, the IRQ is set and remains set as long as the condition exists. After the IRQ condition is removed, the condition is cleared by reading the corresponding status register. Trying to clear the bit while the condition still exists does not allow the bit to be cleared if the bit is sticky.

CONFIG.IRQ\_POL determines the active level of the IRQ. A logic 1 configures IRQ to be active high.

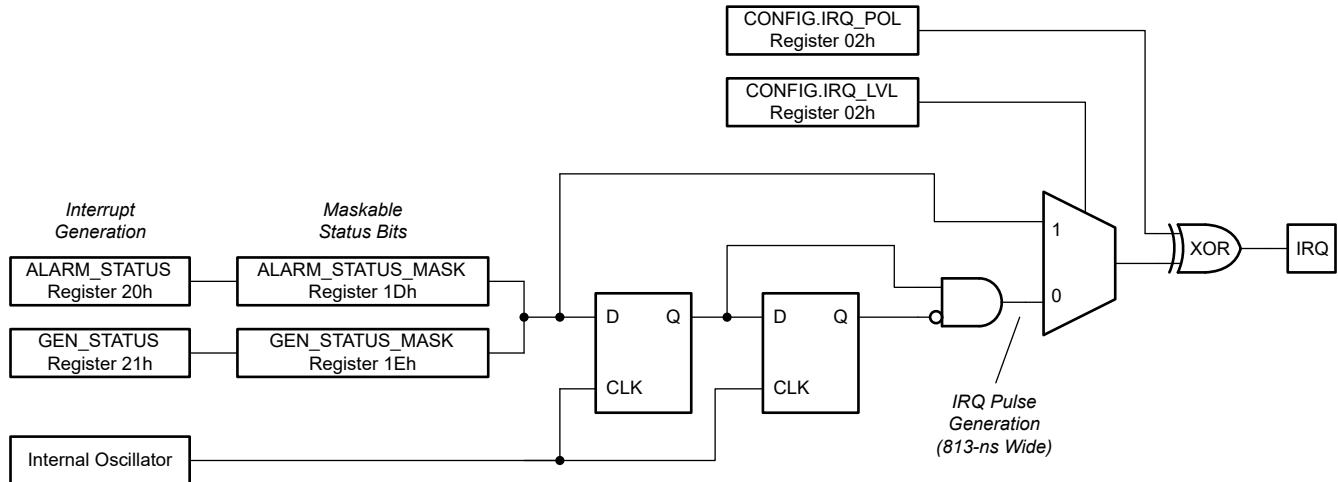
When using edge-sensitive IRQ signals, there is a clock cycle delay for synchronization and edge detection. With a 307.2-kHz clock, this delay is up to 3.26  $\mu$ s. For level-sensitive mode, the delay is approximately 10 ns to 20 ns.

Most status bits have two versions within the design. The first version is an edge event that is created when the status is asserted. This signal is used to generate edge-sensitive IRQs. This edge detection prevents multiple status events from blocking one another. The second version is the sticky version of the status bit. This signal is set upon assertion of the status bit and cleared when the corresponding status register is read, as long as the status condition does not still persist. Signals GEN\_IRQ and ALARM\_IRQ are driven by the logical OR of the of the status bits within the corresponding register.

If a status bit is unmasked and the sticky version of that bit has been asserted, and the IRQ is level-sensitive, then an interrupt is triggered as soon as the bit is unmasked. If the IRQ is edge-sensitive then a status event must occur after the bit has been unmasked to assert an interrupt.

### 7.3.5 Internal Reference

The AFEx8101 family of devices includes a 1.25-V precision band-gap reference. The internal reference is externally available at the VREFIO pin and sources up to 2.5 mA. For noise filtering, use a 100-nF capacitor between the reference output and GND.

The internal reference circuit is enabled or disabled by using the REF\_EN pin. A logic high on this pin enables the internal reference, and the VREFIO pin outputs 1.25 V. A logic low on this pin disables the internal reference, and the device expects to have 1.25 V from external VREF at the VREFIO pin.

An invalid reference voltage asserts an alarm condition. The DAC response depends on the VREF\_FLT setting in the ALARM\_ACT register (10h).

### 7.3.6 Integrated Precision Oscillator

The internal time base of the device is provided by an internal oscillator that is trimmed to less than 0.5% tolerance at room temperature. The precision oscillator is the timing source for ADC conversions. At power up, the internal oscillator and ADC take roughly 300  $\mu$ s to reach < 1% error stability. After the clock stabilizes, the ADC data output is accurate to the electrical specifications provided in [节 6](#).

### 7.3.7 One-Time Programmable (OTP) Memory

One-time programmable (OTP) memory in the device is used to store the device trim settings and is not accessible to users. The OTP memory data are loaded to the memory at power up. The OTP memory CRC is performed to verify the correct data are loaded. The TRIGGER.SHADOWLOAD bit is available to initiate a reload of the OTP memory data if a CRC error is detected. The SPECIAL\_CFG.OTP\_LOAD\_SW\_RST bit controls whether the OTP memory data are reloaded with a software reset.

## 7.4 Device Functional Modes

### 7.4.1 DAC Power-Down Mode

Power-down mode facilitates rapid turn-off of the voltage at the DAC output. The DAC can be set to enter and exit power-down mode through hardware, software, or automatically in response to an alarm event. The DAC output is specified for glitch-free performance when going into and out of power-down mode.

Power-down mode is also be enabled by setting DAC\_CFG.PD to 1. In power-down mode, the DAC output amplifier powers down and the DAC output pin is put into the Hi-Z configuration. The DAC output remains in power-down mode until the DAC output is re-enabled.

Alarm control of the power-down mode is enabled by setting the alarm events as DAC power-down sources. The alarm events that trigger the DAC output power-down state must be specified in the ALARM\_ACT register. After the alarm bit is cleared, the DAC returns to normal operation, as long as no other power-down controlling alarm event has been triggered.

The DAC register does not change when the DAC enters power-down mode, which enables the device to return to the original operating point after return from the power-down mode. Additionally, the DAC register can be updated while the DAC is in power-down mode, thus allowing the DAC to output a new value upon return to normal operation.

### 7.4.2 Reset

There are three reset mechanisms in the device: a power-on reset (POR), a  $\overline{\text{RESET}}$  pin, and the SW\_RST command that can be sent through the either the SPI or by UBM.

When power is first applied to the device, a POR circuit holds the device in reset until all supplies reach the specified operating voltages. The power-on reset returns the device to a known operating state in case a brownout event occurs (when the supplies have dipped below the minimum operating voltages). The POR starts all digital circuits in reset as the supply settles, and releases them to make sure that the device starts in the default condition and loads the OTP memory. After the OTP memory has been loaded, the  $\overline{\text{ALARM}}$  pin is released. At this time, communication with the device is safe. This  $t_{\text{POR}}$  time is less than 100  $\mu\text{s}$ .

The devices also have a  $\overline{\text{RESET}}$  pin that is used as a hardware reset to the device. Send the  $\overline{\text{RESET}}$  pin low for a minimum of 100 ns ( $t_{\text{RESET}}$ ) to reset the device. A delay time of 10  $\mu\text{s}$  ( $t_{\text{RESETWAIT}}$ ) is required before sending the first serial interface command as the device latches and releases the reset. The release of the internal reset state is synchronized to the internal clock. The  $\overline{\text{RESET}}$  pin resets the SPI and the UART interfaces, the watchdog timer, the internal oscillator, and the device registers.  $\overline{\text{RESET}}$  does not reload the OTP memory.

The command to RESET.SW\_RST = 0xAD resets the device as a software reset. The command is decoded at the rising edge of  $\overline{\text{CS}}$  with an SPI command or during the stop bit of the last character of a UBM frame. Set UBM.REG\_MODE again to put the device back into UBM when resetting the device in UBM. After sending the RESET command, no delay time is required before sending the first serial interface command as the device latches and releases the reset. The reset is synchronized to the falling edge of the internal clock and is released well before the next rising edge. The  $\overline{\text{ALARM}}$  pin pulses low for the width of the internal reset. This pulse duration is less than 20 ns. This command resets the SPI and the UART interface, and the watchdog timer, but does not reset the internal oscillator. The software reset also reloads internal factory trim registers if properly configured in the SPECIAL\_CFG register. The SPECIAL\_CFG register is only reset with a POR.

The POR and hardware reset place the internal oscillator into a reset condition, which holds the clock low. When these two signals are released, there is a delay of a few microseconds before the first rising edge of the clock. The hardware reset,  $\overline{\text{RESET}}$ , pulse width must be at least 100 ns to allow the oscillator to properly reset. The SW\_RST command is a short pulse. This pulse is not long enough to adequately reset the oscillator. The SW\_RST is asserted with a falling edge of the clock. As a result of the long oscillator period, the design architecture provides that all devices are out of reset by the next rising edge.

图 7-16 shows the reset tree.



图 7-16. Reset Conditions

## 7.5 Programming

The AFE8101 communicate with the system controller through a serial interface that supports either a UART-compatible two-wire bus or an SPI-compatible bus. Based on the hardware configuration, either interface can be enabled. [图 7-17](#) and [图 7-18](#) show the configurations to enable SPI mode and UART break mode (UBM), respectively. The SPI supports an 8-bit frame-by-frame CRC that is enabled by default, but can be disabled by the user. UBM does not support CRC, but does support the UART protocol parity bit.

### 7.5.1 Communication Setup

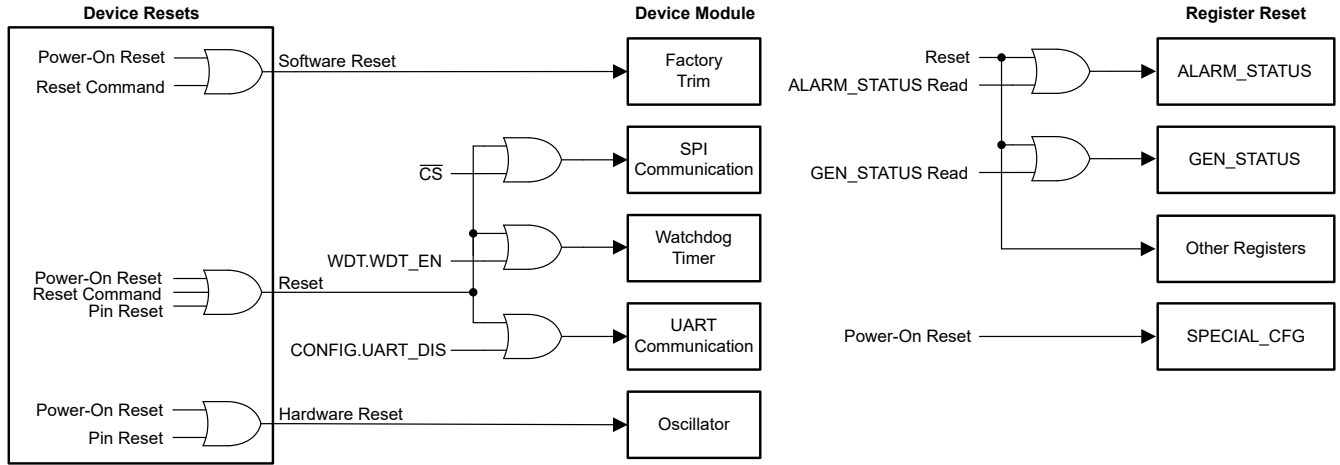
After any reset or power up, the AFE8101 wake up able to use the SPI or UART break mode (UBM). The devices include a robust mechanism that configures the interface between either an SPI-compatible or UART-compatible protocol based system, thus preventing protocol change during normal operation. The selection is based on initial conditions from the respective hardware configurations (see [图 7-17](#) and [图 7-18](#)) and any subsequent user configuration.

#### 7.5.1.1 SPI Mode

By default, the AFE8101 can be fully accessed with the SPI (except UBM.REG\_MODE). To set up the device in SPI mode:

1. Set CONFIG.UART\_DIS = 1 (disables the UART communication).
2. Optionally, set CONFIG.DSDO, CONFIG.FSDO, CONFIG.CLR\_PIN\_EN, and CONFIG.IRQ\_PIN\_EN. For details, see [表 7-14](#).

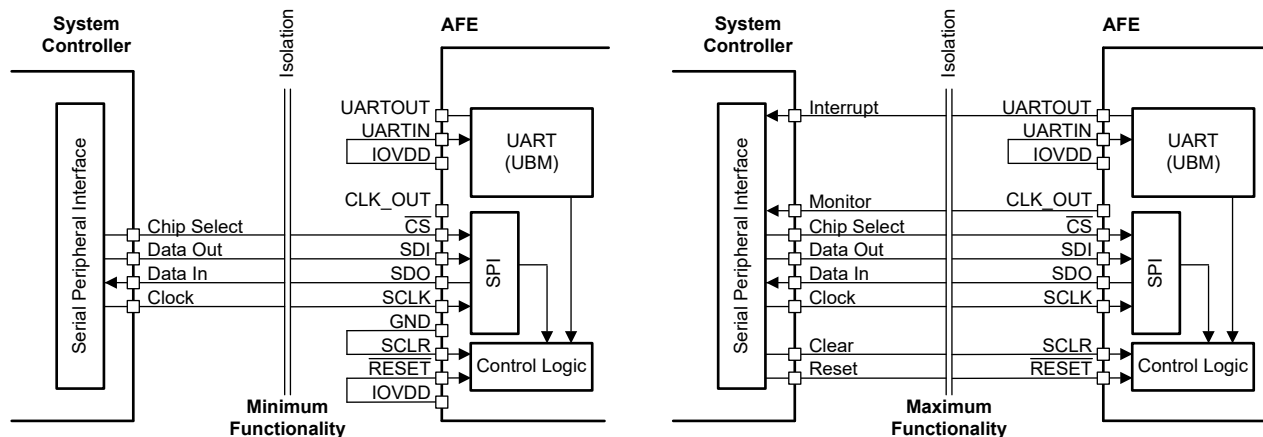

**图 7-17. SPI Mode Connections**

[图 7-17](#) shows the SPI mode logical connections (through the isolation barrier, if used) for both minimum functionality (all optional pins disconnected) and maximum functionality (all pins connected). If CONFIG.IRQ\_PIN\_EN = 1 is set, then the UARTOUT pin functions as the IRQ output. In SPI mode, set CONFIG.SDO\_DSDO = 0 to enable the readback function. This function is disabled by default to save power. If the readback function not enabled, SDO remains in Hi-Z mode even during the subsequent frame after a read request.

#### 7.5.1.2 UART Mode

At power up, the UART interface is set to 9600 baud with UBM enabled. Any reset clears the UBM register, and the register must be set again to use UBM. To set up the device in UBM:

1. Using UBM, set UBM.REG\_MODE = 1 at 9600 baud. This setting blocks the SPI from accessing the device and enables the UART interface access to the entire register map.
2. Optionally, set CONFIG.CLR\_PIN\_EN and CONFIG.IRQ\_PIN\_EN (See [表 7-14](#) for details).

[图 7-18](#) shows the UBM logical connections (through the isolation barrier, if used) for both minimum functionality (all optional pins disconnected) and maximum functionality (all pins connected). If CONFIG.IRQ\_PIN\_EN = 1 is

set, then the SDO pin functions as the IRQ output. If CONFIG.CLR\_PIN\_EN = 1 is set, then the SDI pin controls the clear pin function.



图 7-18. UBM (UART Interface) Connections

### 7.5.2 Serial Peripheral Interface (SPI)

The AFE8101 are controlled over a versatile four-wire serial interface (SDIN, SDO, SCLK, and  $\overline{CS}$ ). The interface operates at clock rates of up to 12.5 MHz and is compatible with SPI, QSPI, Microwire, and digital signal processing (DSP) standards. The SPI communication command consists of a read or write address, a data word, and an optional CRC byte.

The SPI can access all register addresses except for the UBM register. Read-only and read-write capability is defined by register (see 表 7-10). The SPI supports both SPI Mode 1 (CPOL = 0, CPHA = 1) and SPI Mode 2 (CPOL = 1, CPHA = 0). The default SCLK value is low for SPI Mode 1 and high for SPI Mode 2. See 节 6.7 for timing diagrams in each mode. The serial clock, SCLK, can be continuous or gated.

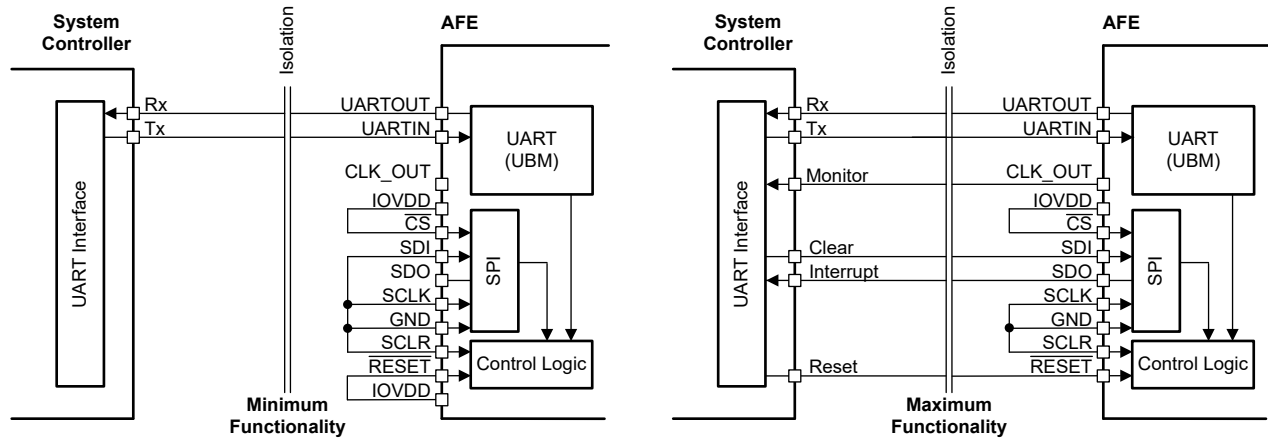
#### 7.5.2.1 SPI Frame Definition

Subject to the timing requirements listed in the [Timing Requirements](#), the first SCLK falling edge immediately following the falling edge of  $\overline{CS}$  captures the first frame bit. Subject to the same requirements, the last SCLK falling edge before the rising edge of  $\overline{CS}$  captures the last bit of the frame. 图 7-19 shows that the SPI shift register frame is 32-bits wide, and consists of an R/W bit, followed by a 7-bit address, and a 16-bit data word. The 8-bit CRC is optional (enabled by default) and is disabled by setting CONFIG.CRC\_EN = 0 (see also 节 7.5.2.3). 图 7-20 shows that when the CRC is disabled, the frame is 24-bits wide.



图 7-19. SPI Frame Details (Default, CRC Enabled)



图 7-20. SPI Frame Details (CRC Disabled)

For a valid frame, a full frame length of data (24 bits if CRC is disabled or 32 bits if CRC is enabled) must be transmitted before  $\overline{CS}$  is brought high. If  $\overline{CS}$  is brought high before the last falling SCLK edge of a full frame, then the data word is not transferred into the internal registers. If more than a full frame length of falling SCLK edges are applied before  $\overline{CS}$  is brought high, then the last full frame length number of bits are used. In other words, if the number of falling SCLK edges while  $\overline{CS} = 0$  is 34, then the last 32 SCLK cycles (or 24 if CRC is disabled) are treated as the valid frame. The device internal registers are updated from the SPI shift register on the rising edge of  $\overline{CS}$ . To start another serial transfer, bring  $\overline{CS}$  low again. When  $\overline{CS}$  is high, the SCLK and SDI signals are blocked and the SDO pin is high impedance.

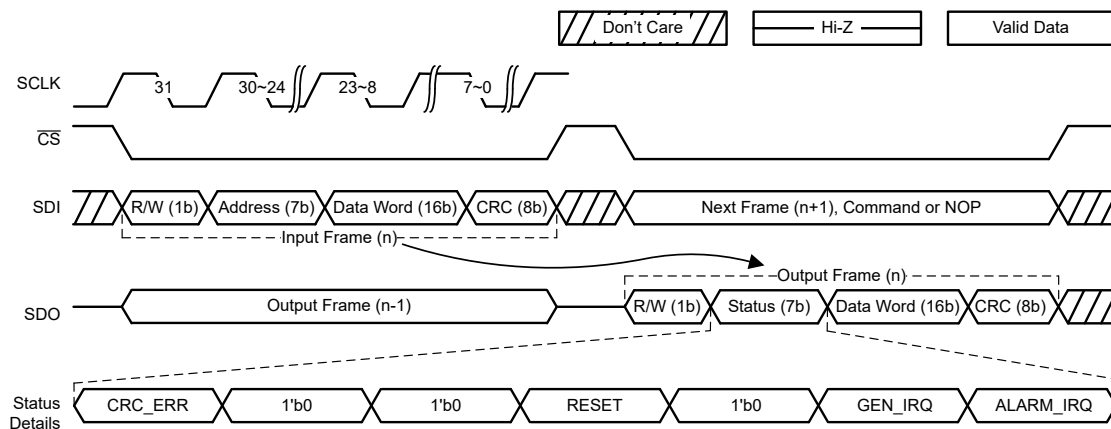
### 7.5.2.2 SPI Read and Write

The SDI input bit is latched on the SCLK falling edge. The SDI pin receives right-justified data. At the rising edge of  $\overline{CS}$ , the right-most (last) bits are evaluated as a frame. Extra clock cycles (exceeding frame length) during the frame begin to output on SDO the SDI data delayed by one frame length.

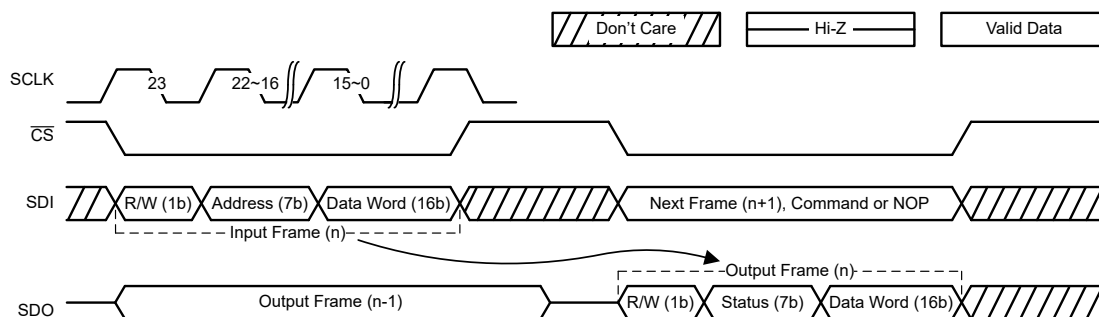
A read operation is started when R/W bit is 1. The data word input for SDI is ignored in the read command frame. Send the subsequent read or write command frame into SDI to clock out the data of the addressed register on SDO. If no other read or write commands are needed, then issue a NOP command to retrieve the requested data. The read register value is output most significant bit first on SDO on successive edges (rising or falling based on CONFIG.FSDO setting) of SCLK.

A write operation starts when R/W bit is 0. The SDO output to a write command, delivered in the next frame, contains status bits, data described in 表 7-8, and if the CRC is enabled, an 8-bit CRC for the output frame.

表 7-8. Command Functions

COMMAND BIT	SDI INPUT DATA WORD	SDO RESPONSE DATA WORD <sup>(1)</sup>
Write (R/W = 0)	Data to be written (16b)	0x0000
Read (R/W = 1)	Ignored <sup>(2)</sup>	Register output data (16b)

(1) Response data portion in next frame output.

(2) The input bits are included in the calculation for CRC, if enabled (see 节 7.5.2.3).

Valid SDO output is driven only when  $\overline{CS} = 0$  and CONFIG.DSDO = 0; otherwise, the SDO pin remains Hi-Z to save power. The SDO data bits are left-justified within the frame, meaning the most significant bit is produced on the line (subject to timing details) when  $\overline{CS}$  is asserted low (bit is driven by falling edge of  $\overline{CS}$ ). The subsequent bits in the frame are driven by the rising SCLK edge when CONFIG.FSDO = 0 (default). To drive the SDO data on the falling edge of SCLK, set CONFIG.FSDO = 1. This setting effectively gives the SDO data an additional ½ clock period for setup time, but at the expense of hold time.

The frame output on SDO contains the command bit of the input that generated the frame (previous input frame), followed by seven status bits (see 图 7-19). When an input frame CRC error is detected, the status bit CRC\_ERR = 1. If there is no input frame CRC error, then CRC\_ERR = 0. See 表 7-9 for details.

### 7.5.2.3 Frame Error Checking

If the AFEx8101 are used in a noisy environment, use the CRC to check the integrity of the SPI data communication between the device and the system controller. This feature is enabled by default and is



controlled by the CONFIG.CRC\_EN bit. If the CRC is not required in the system, disable frame error checking through the CRC\_EN bit, and switch from the default 32-bit frame to the 24-bit frame.

Frame error checking is based on the CRC-8-ATM (HEC) polynomial:  $x^8 + x^2 + x + 1$  (9'b100000111).

For the output register readback, the AFEx8101 supply the calculated 8-bit CRC for the 24 bits of data provided, as part of the 32-bit frame.

The AFEx8101 decodes 24-bits of the input frame data and the 8-bit CRC to compute the CRC remainder. If no error exists in the frame, the CRC remainder is zero. When the remainder is nonzero (that is, the input frame has single-bit or multiple-bit errors) the ALARM\_STATUS.CRC\_ERR\_CNT bits are incremented. A bad CRC value prevents execution of commands to the device.

When the CRC error counter reaches the limit programmed in CONFIG.CRC\_ERR\_CNT, the CRC\_FLT status bit is set in the ALARM\_STATUS register. The fault is reported (as long as the corresponding mask is not set) as an ALARM\_IRQ on SDO during the next frame. The  $\overline{\text{ALARM}}$  pin asserts low if enabled by the alarm action configuration (see 节 7.3.3.1).

The CRC\_ERR status bit (see 图 7-19) in the SDO frame is not sticky and is only reported for the previous frame. The ALARM\_STATUS.CRC\_FLT bit is sticky and is only cleared after a successful read of the ALARM\_STATUS register. Read the GEN\_STATUS or ALARM\_STATUS registers to clear any sticky bits that are set.

The sticky status bits are cleared at the start of the readback frame and are latched again at the end of the readback frame. Therefore, if the fault condition previously reported in the status register is no longer present at the end of the readback frame, and the data are received by the microcontroller with the CRC error, the fault information is lost. If a robust monitoring of the status bits is required in a noisy environment, use the IRQ pin in combination with the status mask bits to find out the status of each fault before clearing the status bits. Set the CONFIG.IRQ\_LVL bit to monitor the signal level on the IRQ pin, and unmask each status bit one at a time to retrieve the information from the status registers.

#### 7.5.2.4 Synchronization

The AFEx8101 register map runs on the internal clock domain. Both the SPI and UBM packets are synchronized to this domain. This synchronization adds a latency of 0.4  $\mu\text{s}$  to 1.22  $\mu\text{s}$  (1.5 internal clocks), with respect to the rising edge of  $\overline{\text{CS}}$  or the STOP bit of the last byte of the UBM packet.

The effect of clock synchronization on UBM communication is not evident because of the lower speed and asynchronous nature of UBM communication.

In SPI mode, if changing register bits CONFIG.DSDO, CONFIG.FSDO, or CONFIG.CRC\_EN, keep  $\overline{\text{CS}}$  high for at least two clock cycles before issuing the next frame. Frame data corruption can occur if the two extra cycles are not used. The following are examples of frame corruption:

- Setting CONFIG.DSDO = 0: SDO begins to drive in the middle of the next frame.
- Changing CONFIG.FSDO: The launching edge of SDO changes in the middle of the next frame.
- Setting CONFIG.CRC\_EN = 1: The next frame has a CRC error because the CRC is enabled in the middle of the frame.

Send a NOP command (SDI = 0x00\_0000) after setting the DSDO, FSDO, and CRC\_EN bits to prevent the corrupted frames from impacting communication. Sending a NOP after CONFIG.CRC\_EN is set still generates a CRC error, and is reported in the STATUS portion of SDO. To avoid false errors, wait approximately 2  $\mu\text{s}$  after setting CONFIG.CRC\_EN before sending the next frame.

### 7.5.3 UART

In UART mode, the device expects 1 start bit, 8 data bits, 1 odd parity bit, and 1 stop bit, or an 8O1 UART character format.

#### 7.5.3.1 UART Break Mode (UBM)

In UART break mode (UBM), the microcontroller issues a UART break to start communication. The device interprets the UART break as the start to receive commands from the UART. A communication UART character consists of one start bit, eight data bits, one odd parity bit, and at least one stop bit. A UART break character is all 11 bits (including start, data, parity and stop bit) held low by the microcontroller on the UARTIN pin and by the AFE8101 on the UARTOUT pin. When a valid break character is detected on UARTIN by the AFE8101, no parity (even though parity is odd) or stop bit errors are flagged for this character. The parity and stop bit differences between valid UBM break and communication characters must be managed by the system microcontroller when receiving these characters from the UARTOUT pin of the AFE8101. See [Figure 6-2](#) for UBM break character, communication timing details, and bit order.

AFE8101 UART break mode communication is supported at 9600 baud.

Set UBM.REG\_MODE = 1 to enable register map access through the UART. By default, this bit is set to 0. The entire register map can only be accessed with SPI, except for the UBM register. The UBM register can only be accessed with UBM. After UBM.REG\_MODE is set to 1, the SPI does not have access to the register map, and the full register map is accessible by UBM.

A UBM data output packet is initiated by AFE8101 on UARTOUT in two cases. See [Figure 7-23](#) for packet structure details. If the R/IRQn status bit is 0 an IRQ event initiated the break command. If the R/IRQn status bit is 1, the break command is a response to the prior read request.

To enable IRQ events, set CONFIG.UBM\_IRQ\_EN = 1. When IRQ is enabled, the AFE8101 triggers a break command followed by data on UARTOUT (see [Figure 7-23](#)).

The contents of the data are listed in order of priority below.

1. If ALARM\_IRQ bit is set, then the contents of the ALARM\_STATUS register are output.
2. If GEN\_IRQ is set, then the contents of the GEN\_STATUS register are output.
3. If none of the previous bits are set, then an IRQ is not generated.

A break byte is followed by three bytes. These three bytes have information identical to the SPI frame without the CRC (see [Figure 7-20](#)). The CRC cannot be enabled for UBM. All communication characters on the UART bus are transmitted least significant data bit (D0) first.

[Figure 7-21](#) shows the data structure of the UBM write command, and [Figure 7-22](#) shows the data structure of the UBM read command.

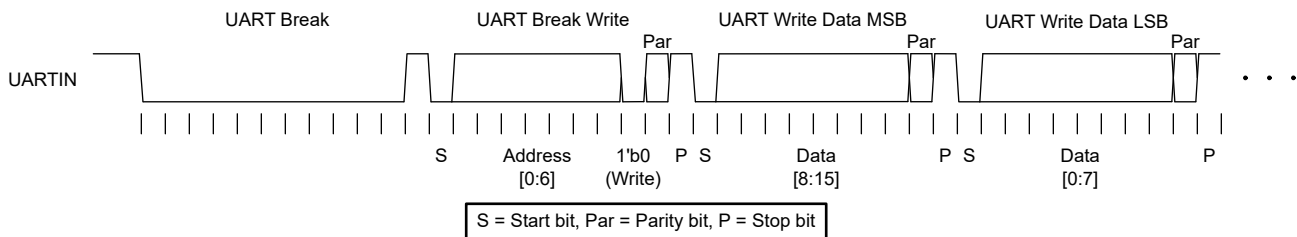

**图 7-21. UARTIN Break Write Data Format**

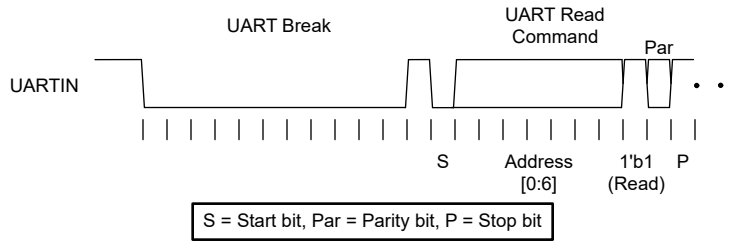

**图 7-22. UARTIN Break Read Data Format**

图 7-23 shows the UARTOUT data frame with details of the status bits produced by the AFEx8101. See 表 7-9 for details.

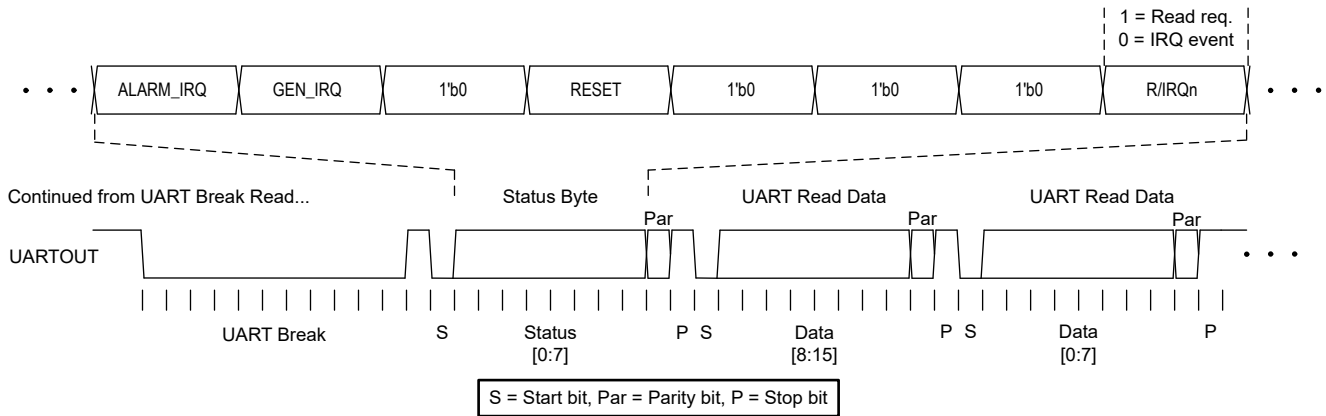

**图 7-23. UARTOUT Break Data Format**

### 7.5.4 Status Bits

Every response, in SPI mode and UBM, from the AFEx8101 includes a set of status bits. For SPI mode bit order, see [节 7.5.2.1](#), and for UBM bit order, [节 7.5.3.1](#).

表 7-9. Status Bits

STATUS BIT	DESCRIPTION	NOTES / REFERENCE
ALARM_IRQ	1h = ALARM_IRQ asserted 0h = Normal operation	From the GEN_STATUS <sup>(1)</sup> register (表 7-33). Also see <a href="#">节 7.3.4</a> .
CRC_ERR (CRC enabled SPI only)	1h = CRC error detect in input frame 0h = No CRC error detected	Generated by the SPI on a frame by frame basis. See <a href="#">节 7.5.2.3</a> .
GEN_IRQ	1h = GEN_IRQ asserted 0h = Normal Operation	From the ALARM_STATUS <sup>(1)</sup> register (表 7-32). Also see <a href="#">节 7.3.4</a> .
R/IRQn (UBM only)	1h = Read request 0h = IRQ event	Generated by the UART interface on a frame by frame basis. See <a href="#">节 7.5.3.1</a> for details.
RESET	1h = First readback after RESET 0h = All other readbacks	From the GEN_STATUS register (表 7-33). Also see <a href="#">节 7.4.2</a> .

(1) ALARM\_STATUS, and GEN\_STATUS registers contain cross-readable IRQ flags for the other register. The ALARM\_STATUS register has the GEN\_IRQ bit. GEN\_STATUS has the ALARM\_IRQ bit. This functionality enables the system microcontroller to always get full status information by reading only one register, and thus save power.

### 7.5.5 Watchdog Timer

The AFEx8101 include a watchdog timer (WDT) that is used to make sure that communication between the system controller and the device is not lost. The WDT checks that the device received a communication from the system controller within a programmable period of time. To enable this feature, set WDT.WDT\_EN to 1. The WDT monitors both SPI and UBM communications.

The WDT has two limit fields: WDT.WDT\_UP and WDT.WDT\_LO. The WDT\_UP field sets the upper time limit for the WDT. The WDT\_LO field sets the lower time limit. If the WDT\_LO is set to a value other than 2' b00, then the WDT acts as a window comparator. If the write occurs too quickly (less than the WDT\_LO time), or too slowly (greater than the WDT\_UP time), then a WDT error is asserted. When acting as a window comparator, in the event of a WDT error, the WDT resets only when a write to the WDT register occurs. If the WDT\_LO is set to 2'b00, then a write to any register resets the WDT time counter. In this mode, the WDT error is asserted when the timer expires.

If enabled, the chip must have any SPI or UBM write to the device within the programmed timeout window. Otherwise, the  $\overline{\text{ALARM}}$  pin asserts low, and the ALARM\_STATUS.WD\_FLT bit is set to 1. The WD\_FLT bit is sticky. After a WD\_FLT has been asserted, WDT.WDT\_EN must be set to 0 to clear the WDT condition. Then the WDT can be re-enabled. The WDT condition is also cleared by issuing a software or hardware reset. After the WDT condition is clear, WD\_FLT is cleared by reading the ALARM\_STATUS register.

The watchdog timeout period is based on a 1200-Hz clock (1.2288 MHz / 1024).

## 7.6 Register Maps

表 7-10 lists the memory-mapped registers for the AFE8101 registers. Consider all register offset addresses not listed in 表 7-10 as reserved locations; do not modify these register contents.

**表 7-10. Register Map**

ADDR (HEX)	REGISTER	BIT DESCRIPTION															
		15	14	13	12	11	10	9	8	7	6	5	4	3	2	1	0
00h	NOP	NOP [15:0]															
01h	DAC_DATA	DATA [15:0]															
02h	CONFIG	RESERVED	CRC_ERR_CNT [1:0]		CLKO_DIV	CLKO_EN	RESERVED	UBM_IRQ_EN	IRQ_PIN_EN	CLR_PIN_EN	UART_DIS	RESERVED	CRC_EN	IRQ_POL	IRQ_LVL	DSDO	FSDO
03h	DAC_CFG	RESERVED			PD	SR_CLK [2:0]			SR_STEP [2:0]			SR_EN	SR_MODE	RESERVED	CLR	CLR_RANGE	RANGE
04h	DAC_GAIN	GAIN [15:0]															
05h	DAC_OFFSET	OFFSET [15:0]															
06h	DAC_CLR_CODE	CODE [15:0]															
07h	RESET	RESERVED								SW_RST [7:0]							
08h	ADC_CFG	BUF_PD	HYST [6:0]						FLT_CNT [2:0]			AIN_RANGE	EOC_PER_CH	CONV_RATE [1:0]		DIRECT_MODE	
09h	ADC_INDEX_CFG	RESERVED								STOP [3:0]			START [3:0]				
0Ah	TRIGGER	RESERVED														SHADOW_LOAD	ADC
0Bh	SPECIAL_CFG (1)	RESERVED													OTP_LOAD_SW_RST	ALMV_POL	AIN1_ENB
10h	ALARM_ACT	SD_FLT [1:0]		TEMP_FLT [1:0]		AIN1_FLT [1:0]		AIN0_FLT [1:0]		CRC_WDT_FLT [1:0]		VREF_FLT [1:0]		THERM_ERR_FLT [1:0]		THERM_WARN_FLT [1:0]	
11h	WDT	RESERVED										WDT_UP [2:0]			WDT_LO [1:0]		WDT_EN
12h	AIN0_THRESHOLD	Hi [7:0]								Lo [7:0]							
13h	AIN1_THRESHOLD	Hi [7:0]								Lo [7:0]							
14h	TEMP_THRESHOLD	Hi [7:0]								Lo [7:0]							
16h	UBM (2)	RESERVED															REG_MODE
1Dh	ALARM_STATUS_MASK	RESERVED		SD_FLT	OSC_FAIL	RESERVED			OTP_CRC_ERR	CRC_FLT	WD_FLT	VREF_FLT	ADC_AIN1_FLT	ADC_AIN0_FLT	ADC_TEMP_FLT	THERM_ERR_FLT	THERM_WARN_FLT
1Eh	GEN_STATUS_MASK	RESERVED								SR_BUSYn	ADC_EOC	RESERVED		BREAK_FRAME_ERR	BREAK_PARITY_ERR	UART_FRAME_ERR	UART_PARITY_ERR
20h	ALARM_STATUS	GEN_IRQ	RESERVED	SD_FLT	OSC_FAIL	CRC_CNT [1:0]		OTP_LOADEDn	OTP_CRC_ERR	CRC_FLT	WD_FLT	VREF_FLT	ADC_AIN1_FLT	ADC_AIN0_FLT	ADC_TEMP_FLT	THERM_ERR_FLT	THERM_WARN_FLT

表 7-10. Register Map (continued)

ADDR (HEX)	REGISTER	BIT DESCRIPTION															
		15	14	13	12	11	10	9	8	7	6	5	4	3	2	1	0
21h	<a href="#">GEN_STATUS</a>	ALARM_IRQ	RESERVED		OTP_BUSY	RESERVED			RESET	SR_BUSY <sub>n</sub>	ADC_EOC	ADC_BUSY	PVDD_HI	BREAK_FRAME_ERR	BREAK_PARITY_ERR	UART_FRAME_ERR	UART_PARITY_ERR
23h	<a href="#">ADC_FLAGS</a>	RESERVED							SD4_FAIL	SD3_FAIL	SD2_FAIL	SD1_FAIL	SD0_FAIL	TEMP_FAIL	AIN1_FAIL	AIN0_FAIL	RESERVED
24h	<a href="#">ADC_AIN0</a>	RESERVED				DATA [11:0]											
25h	<a href="#">ADC_AIN1</a>	RESERVED				DATA [11:0]											
26h	<a href="#">ADC_TEMP</a>	RESERVED				DATA [11:0]											
27h	<a href="#">ADC_SD_MUX</a>	RESERVED				DATA [11:0]											
28h	<a href="#">ADC_OFFSET</a>	RESERVED				DATA [11:0]											
2Ch	<a href="#">DAC_OUT</a>	DATA [15:0]															
2Dh	<a href="#">ADC_OUT</a>	RESERVED				DATA [11:0]											
2Eh	<a href="#">ADC_BYP</a>	DATA_BYP_EN	OFST_BYP_EN	DIS_GND_SAMP	RESERVED	DATA [11:0]											
2Fh	<a href="#">FORCE_FAIL</a>	CRC_FLT	VREF_FLT	THERM_ERR_FLT	THERM_WARN_FLT	RESERVED	SD4_HI_FLT	SD4_LO_FLT	SD3_HI_FLT	SD3_LO_FLT	SD2_HI_FLT	SD2_LO_FLT	SD1_HI_FLT	SD1_LO_FLT	SD0_HI_FLT	SD0_LO_FLT	

- (1) The SPECIAL\_CFG register can only be reset with POR, and does not respond to the RESET pin or SW\_RST command.
- (2) The UBM register can only be accessed with a UBM command.

### 7.6.1 AFEx8101 Registers

Complex bit access types are encoded to fit into small table cells. 表 7-11 shows the codes that are used for access types in this section.

**表 7-11. AFEx8101 Access-Type Codes**

Access Type	Code	Description
<b>Read Type</b>		
R	R	Read
<b>Write Type</b>		
W	W	Write
W	WO	Write only
W	WSC	Write self clear
<b>Reset or Default Value</b>		
-n		Value after reset or the default value
<b>Register Array Variables</b>		
i,j,k,l,m,n		When used in a register name, an offset, or an address, these variables refer to the value of a register array where the register is part of a group of repeating registers. The register groups form a hierarchical structure and the array is represented with a formula.
y		When used in a register name, an offset, or an address, this variable refers to the value of a register array.

#### 7.6.1.1 NOP Register (Offset = 0h) [Reset = 0000h]

Return to the [Register Map](#).

**表 7-12. NOP Register Field Descriptions**

Bit	Field	Type	Reset	Description
15-0	NOP	WO	0h	No operation. Data written to this field have no effect. Always reads zeros.

#### 7.6.1.2 DAC\_DATA Register (Offset = 1h) [Reset = 0000h]

Return to the [Register Map](#).

DAC code for VOUT.

**表 7-13. DAC\_DATA Register Field Descriptions**

Bit	Field	Type	Reset	Description
15-0	DATA	R/W	0h	Data. DAC code for VOUT.

### 7.6.1.3 CONFIG Register (Offset = 2h) [Reset = 0036h]

Return to the [Register Map](#).

**表 7-14. CONFIG Register Field Descriptions**

Bit	Field	Type	Reset	Description
15	RESERVED	R	0h	
14-13	CRC_ERR_CNT	R/W	0h	CRC Errors Count Limit Sets the numbers of consecutive SPI CRC frames that must have errors before the status bits is set. 0h = 1 (default); 1h = 2; 2h = 4; 3h = 8
12	CLKO_DIV	R/W	0h	CLKO Divider Divide the clock by 128 to output to CLKO. 0h = Divider disabled, output 1.2288 MHz (default) 1h = Divider enabled, output 9600 Hz
11	CLKO_EN	R/W	0h	CLKO Enable Enable the internal oscillator to be driven on CLKO pin. 0h = Disabled (default); 1h = Enabled
10	RESERVED	R	0h	
9	UBM_IRQ_EN	R/W	0h	UBM IRQ Enable Enable IRQ to be sent on UARTOUT through UBM. 0h = Disabled (default); 1h = Enabled
8	IRQ_PIN_EN	R/W	0h	IRQ Pin Enable Enable IRQ pin functionality. 0h = Disabled (default); 1h = Enabled
7	CLR_PIN_EN	R/W	0h	Clear Input Pin Enable Enable pin-based transition to the CLEAR state in UBM and SPI. 0h = Disabled (default); 1h = SCLR pin enabled in SPI mode or SDI pin configured as clear input pin in UBM
6	UART_DIS	R/W	0h	UART Disable Disable UART functionality. 0h = Disabled (default); 1h = Enabled
5	RESERVED	R	1h	Reserved. Always set this bit to 1h for proper functionality.
4	CRC_EN	R/W	1h	CRC Enable Enable CRC for SPI. 0h = Disabled; 1h = Enabled (default)
3	IRQ_POL	R/W	0h	IRQ Polarity 0h = Active low (default); 1h = Active high
2	IRQ_LVL	R/W	1h	IRQ Level 0h = Edge sensitive 1h = Level sensitive (default)
1	DSDO	R/W	1h	SDO Hi-Z 0h = Drive SDO during $\overline{CS} = 0$ 1h = SDO always Hi-Z (default)
0	FSDO	R/W	0h	Fast SDO SDO is driven on negative edge of SCLK. 0h = drive SDO on rising edge of SCLK (launching edge) (default) 1h = drive SDO on falling edge of SCLK (capture edge 1/2 clock early)



### 7.6.1.4 DAC\_CFG Register (Offset = 3h) [Reset = 0B00h]

Return to the [Register Map](#).

**表 7-15. DAC\_CFG Register Field Descriptions**

Bit	Field	Type	Reset	Description
15-13	RESERVED	R/W	0h	
12	PD	R/W	0h	DAC Output Buffer Power-down DAC output set to Hi-Z in power-down. 0h = DAC output buffer enabled (default) 1h = DAC output buffer disabled
11-9	SR_CLK	R/W	5h	Slew Clock Rate 0h = 307.2 kHz 1h = 153.6 kHz 2h = 76.8 kHz 3h = 38.4 kHz 4h = 19.2 kHz 5h = 9600 Hz (default) 6h = 4800 Hz 7h = 2400 Hz
8-6	SR_STEP	R/W	4h	Slew Step Size 0h = 1 code 1h = 2 codes 2h = 4 codes 3h = 8 codes 4h = 16 codes (default) 5h = 32 codes 6h = 64 codes 7h = 128 codes
5	SR_EN	R/W	0h	Slew Enable Enables slew on the output voltage. 0h = Disabled (default) 1h = Enabled
4	SR_MODE	R/W	0h	Slew Mode Output slew rate mode select. 0h = Linear Slew (default) 1h = Sinusoidal Slew
3	RESERVED	R	0h	
2	CLR	R/W	0h	CLEAR State 0h = Normal operation (default) 1h = Force the DAC to the CLEAR state
1	CLR_RANGE	R/W	0h	Clear Range Sets DAC CLEAR state output range. 0h = 0.15 V to 1.25 V (default) 1h = 0.2 V to 1.0 V
0	RANGE	R/W	0h	Range Sets DAC output range during normal operation. 0h = 0.15 V to 1.25 V (default) 1h = 0.2 V to 1.0 V

### 7.6.1.5 DAC\_GAIN Register (Offset = 4h) [Reset = 8000h]

Return to the [Register Map](#).

表 7-16. DAC\_GAIN Register Field Descriptions

Bit	Field	Type	Reset	Description
15-0	GAIN	R/W	8000h	Gain Set the gain of the DAC output from 0.5 - 1.499985. For example: 0000h = 0.5 8000h = 1.0 (default) FFFFh = 1.499985

### 7.6.1.6 DAC\_OFFSET Register (Offset = 5h) [Reset = 0000h]

Return to the [Register Map](#).

表 7-17. DAC\_OFFSET Register Field Descriptions

Bit	Field	Type	Reset	Description
15-0	OFFSET	R/W	0h	Offset Adjust the offset of the DAC output, 2's complement number. For example: 0000h = 0 (default) FFFFh = - 1

### 7.6.1.7 DAC\_CLR\_CODE Register (Offset = 6h) [Reset = 0000h]

Return to the [Register Map](#).

表 7-18. DAC\_CLR\_CODE Register Field Descriptions

Bit	Field	Type	Reset	Description
15-0	CODE	R/W	0h	CLEAR State DAC Code DAC code applied in the CLEAR state. See <a href="#">节 7.3.1.6</a> .

### 7.6.1.8 RESET Register (Offset = 7h) [Reset = 0000h]

Return to the [Register Map](#).

表 7-19. RESET Register Field Descriptions

Bit	Field	Type	Reset	Description
15-8	RESERVED	R	0h	
7-0	SW_RST	WSC	0h	Software Reset Write ADh to initiate software reset.

### 7.6.1.9 ADC\_CFG Register (Offset = 8h) [Reset = 8810h]

Return to the [Register Map](#).

**表 7-20. ADC\_CFG Register Field Descriptions**

Bit	Field	Type	Reset	Description
15	BUF_PD	R/W	1h	ADC Buffer Power-down 0h = ADC buffer enabled; 1h = ADC buffer powered down (default)
14-8	HYST	R/W	8h	Hysteresis The number of codes of hysteresis used when a threshold is exceeded for an ADC measurement of AIN0/AIN1/TEMP.
7-5	FLT_CNT	R/W	0h	Fault Count Number of successive faults to trip an alarm. Number of successive faults is programmed value + 1 (1-8 faults).
4	AIN_RANGE	R/W	1h	ADC Analog Input Range Can only be set if PVDD $\geq$ 2.7 V to use 2.5-V range for AIN0 and AIN1 inputs. 0h = 2 $\times$ VREF; 1h = 1 $\times$ VREF (default)
3	EOC_PER_CH	R/W	0h	ADC End-of-Conversion for Every Channel Sends an EOC pulse at the end of each channel instead of at the end of all the channels. 0h = EOC after last channel (default); 1h = EOC for every channel
2-1	CONV_RATE	R/W	0h	ADC Conversion Rate This setting only affects the conversion rate for channels AIN0 and AIN1. Rates are based on a 76.8-kHz ADC clock. All other channels use 2560 Hz. 0h = 3840 Hz (default) 1h = 2560 Hz 2h = 1280 Hz 3h = 640 Hz
0	DIRECT_MODE	R/W	0h	Direct Mode Enable 0h = Auto mode (default); 1h = Direct mode

### 7.6.1.10 ADC\_INDEX\_CFG Register (Offset = 9h) [Reset = 0080h]

The ADC custom channel sequencing configuration is shown in [表 7-21](#).

Return to the [Register Map](#).

**表 7-21. ADC\_INDEX\_CFG Register Field Descriptions**

Bit	Field	Type	Reset	Description
15-8	RESERVED	R	0h	
7-4	STOP	R/W	8h	Custom Channel Sequencer Stop Index CCS index to stop ADC sequence. Must be $\geq$ START. If not, STOP is forced to = START. 0h = OFFSET 1h = AIN0 2h = AIN1 3h = TEMP 4h = SD0 (VREF) 5h = SD1 (PVDD) 6h = SD2 (VDD) 7h = SD3 (ZTAT) 8h = SD4 (VOUT) (default) 9h through Fh = GND
3-0	START	R/W	0h	Custom Channel Sequencer Start Index CCS index to start ADC sequence. 0h through Fh = Same as STOP field (0h is default)

### 7.6.1.11 TRIGGER Register (Offset = Ah) [Reset = 0000h]

Return to the [Register Map](#).

表 7-22. TRIGGER Register Field Descriptions

Bit	Field	Type	Reset	Description
15-2	RESERVED	R	0h	
1	SHADOWLOAD	WSC	0h	Shadowload Trigger This trigger initiates the loading of the OTP array into the parallel latches. If an OTP CRC error is detected, assert this trigger to try and reload the OTP into the memory locations.
0	ADC	WSC	0h	ADC Trigger In auto mode, this bit enables or disables the conversions. Manually set 1 (enable) and 0 (disable). In direct mode, setting this bit starts a conversion sequence. The bit is cleared at the end of the sequence. To stop a sequence prematurely, manually clear this bit.

### 7.6.1.12 SPECIAL\_CFG Register (Offset = Bh) [Reset = 0000h]

Return to the [Register Map](#).

表 7-23. SPECIAL\_CFG Register Field Descriptions

Bit	Field	Type	Reset	Description
15-3	RESERVED	R	0h	
2	OTP_LOAD_SW_RST	R/W	0h	OTP (One Time Programmable Factory Trimmed Registers) LOAD with SW RESET OTP reloads with the assertion of a software reset (SW_RST). 0h = No reload with SW_RST 1h = Reload with SW_RST
1	ALMV_POL	R/W	0h	Alarm Voltage Polarity This register bit is ORed with the POL_SEL/AIN1 pin (if AIN1_ENB bit is low) to control the VOUT during a hardware reset condition or if alarm is active and alarm action is set appropriately. The following Boolean function is implemented for the internal signal ALMV_POL_o that sets the VOUT voltage: ALMV_POL_o = ALMV_POL OR (POL_SEL/AIN1 AND NOT AIN1_ENB) 0h = Low (0 V) 1h = High (2.5 V)
0	AIN1_ENB	R/W	0h	AIN1 Pin Enable This bit determines whether the POL_SEL/AIN1 pin acts as alarm voltage polarity control bit or an input channel to the ADC. 0h = AIN1 pin acts as alarm voltage polarity bit and ADC converts GND 1h = AIN1 pin is an active channel to the ADC

### 7.6.1.13 ALARM\_ACT Register (Offset = 10h) [Reset = 8020h]

Return to the [Register Map](#).

**表 7-24. ALARM\_ACT Register Field Descriptions**

Bit	Field	Type	Reset	Description
15-14	SD_FLT	R/W	2h	Self-Diagnostic Fault Action These bits set the device action after a self-diagnostic fault. 0h = No Action 1h = Set DAC to CLEAR state 2h = Switch to alarm voltage determined by ALMV_POL (default) 3h = Place DAC into Hi-Z (power-down)
13-12	TEMP_FLT	R/W	0h	TEMP Fault Action These bits set the device action if the ADC temperature is outside the TEMP_THRESHOLD Hi or Lo thresholds. 0h through 3h = Same as SD_FLT field (default 0h)
11-10	AIN1_FLT	R/W	0h	AIN1 Fault Action These bits set the device action if the ADC AIN1 channel is outside the AIN1_THRESHOLD Hi or Lo thresholds. 0h through 3h = Same as SD_FLT field (default 0h)
9-8	AIN0_FLT	R/W	0h	AIN0 Fault Action These bits set the device action if the ADC AIN0 channel is outside the AIN0_THRESHOLD Hi or Lo thresholds. 0h through 3h = Same as SD_FLT field (default 0h)
7-6	CRC_WDT_FLT	R/W	0h	CRC and WDT Fault Action These bits set the device action when a SPI CRC or SPI Watchdog Timeout error occurs. 0h through 3h = Same as SD_FLT field (default 0h)
5-4	VREF_FLT	R/W	2h	VREF Fault Action These bits set the device action when a fault is detected on VREF. 0h through 3h = Same as SD_FLT field a
3-2	THERM_ERR_FLT	R/W	0h	Thermal Error Fault Action These bits set the device action when a high temperature error occurs (> 130°C). 0h through 3h = Same as SD_FLT field (default 0h)
1-0	THERM_WARN_FLT	R/W	0h	Thermal Warning Fault Action These bits set the device action when a high temperature warning occurs (> 85°C). 0h through 3h = Same as SD_FLT field (default 0h)

### 7.6.1.14 WDT Register (Offset = 11h) [Reset = 0018h]

Return to the [Register Map](#).

表 7-25. WDT Register Field Descriptions

Bit	Field	Type	Reset	Description
15-6	RESERVED	R	0h	
5-3	WDT_UP	R/W	3h	<p>Watchdog Timer (WDT) Upper Limit</p> <p>If the WDT is enabled and the timer exceeds the programmed value, a WDT error is asserted. All times are based on 1200-Hz clock (1.2288 MHz / 1024).</p> <p>0h = 53 ms (64 clocks)</p> <p>1h = 106 ms (128 clocks)</p> <p>2h = 427 ms (512 clocks)</p> <p>3h = 853 ms (1024 clocks, default)</p> <p>4h = 1.7 s (2048 clocks)</p> <p>5h = 2.56 s (3072 clocks)</p> <p>6h = 3.41 s (4096 clocks)</p> <p>7h = 5.12 s (6144 clocks)</p>
2-1	WDT_LO	R/W	0h	<p>WDT Lower Limit</p> <p>If the WDT is enabled and the WDT Lower Limit is enabled, then only a write to this register resets the WDT timer. If the write occurs before the WDT Lower Limit time, or after the WDT Upper Limit time, then a WDT error is asserted. If WDT Lower Limit is disabled, then a write to any register resets the timer. This is true for both SPI and UART Break modes. All times are based on 1200-Hz clock (1.2288 MHz / 1024).</p> <p>0h = Disabled (default)</p> <p>1h = 53 ms (64 clocks)</p> <p>2h = 106 ms (128 clocks)</p> <p>3h = 427 ms (512 clocks)</p>
0	WDT_EN	R/W	0h	<p>WDT Enable</p> <p>0h = Disabled (default); 1h = Enabled</p>

### 7.6.1.15 AIN0\_THRESHOLD Register (Offset = 12h) [Reset = FF0h]

Return to the [Register Map](#).

表 7-26. AIN0\_THRESHOLD Register Field Descriptions

Bit	Field	Type	Reset	Description
15-8	Hi	R/W	FFh	<p>High Threshold for Channel AIN0 {[11:4],4b1111}</p> <p>This value is compared (&gt;) against AIN0 data bits[11:0].</p>
7-0	Lo	R/W	0h	<p>Low Threshold for Channel AIN0 {[11:4],4b0000}</p> <p>This value is compared (&lt;) against AIN0 data bits[11:0].</p>

### 7.6.1.16 AIN1\_THRESHOLD Register (Offset = 13h) [Reset = FF00h]

Return to the [Register Map](#).

**表 7-27. AIN1\_THRESHOLD Register Field Descriptions**

Bit	Field	Type	Reset	Description
15-8	Hi	R/W	FFh	High Threshold for Channel AIN1 {[11:4],4b1111} This value is compared (>) against AIN1 data bits[11:0].
7-0	Lo	R/W	0h	Low Threshold for Channel AIN1 {[11:4],4b0000} This value is compared (<) against AIN1 data bits[11:0].

### 7.6.1.17 TEMP\_THRESHOLD Register (Offset = 14h) [Reset = FF00h]

Return to the [Register Map](#).

**表 7-28. TEMP\_THRESHOLD Register Field Descriptions**

Bit	Field	Type	Reset	Description
15-8	Hi	R/W	FFh	High Threshold for Channel TEMP {[11:4],4b1111} This value is compared (>) against TEMP data bits[11:0].
7-0	Lo	R/W	0h	Low Threshold for Channel TEMP {[11:4],4b0000} This value is compared (<) against TEMP data bits[11:0].

### 7.6.1.18 UBM Register (Offset = 16h) [Reset = 0000h]

Return to the [Register Map](#).

**表 7-29. UBM Register Field Descriptions**

Bit	Field	Type	Reset	Description
15-1	RESERVED	R	0h	
0	REG_MODE	R/W	0h	Register Mode Configure the rest of the Register Map to be accessed by UART break mode (UBM) or SPI. This register can only be written by the UART Break communication. 0h = SPI Mode (default) 1h = UART Break Mode

### 7.6.1.19 ALARM\_STATUS\_MASK Register (Offset = 1Dh) [Reset = EFDh]

Return to the [Register Map](#).

表 7-30. ALARM\_STATUS\_MASK Register Field Descriptions

Bit	Field	Type	Reset	Description
15-14	RESERVED	R	3h	
13	SD_FLT	R/W	1h	SD Fault Mask 0h = Fault asserts IRQ 1h = The mask prevents IRQ or Alarm being triggered (default). The status is always set if the condition exists.
12	OSC_FAIL	R/W	0h	OSC_FAIL Fault Mask Same as SD Fault Mask (default 0h).
11-9	RESERVED	R	7h	
8	OTP_CRC_ERR	R/W	1h	OTP CRC Error Mask Same as SD Fault Mask (default 1h).
7	CRC_FLT	R/W	1h	SPI CRC Fault Mask Same as SD Fault Mask (default 1h).
6	WD_FLT	R/W	1h	Watchdog Fault Mask Same as SD Fault Mask (default 1h).
5	VREF_FLT	R/W	0h	VREF Fault Mask Same as SD Fault Mask (default 0h).
4	ADC_AIN1_FLT	R/W	1h	ADC AIN1 Fault Mask Same as SD Fault Mask (default 1h).
3	ADC_AIN0_FLT	R/W	1h	ADC AIN0 Fault Mask Same as SD Fault Mask (default 1h).
2	ADC_TEMP_FLT	R/W	1h	ADC TEMP Fault Mask Same as SD Fault Mask (default 1h).
1	THERM_ERR_FLT	R/W	1h	Temperature > 130°C Error Mask Same as SD Fault Mask (default 1h).
0	THERM_WARN_FLT	R/W	1h	Temperature > 85°C Warning Mask Same as SD Fault Mask (default 1h).



### 7.6.1.20 GEN\_STATUS\_MASK Register (Offset = 1Eh) [Reset = FFFFh]

Return to the [Register Map](#).

**表 7-31. GEN\_STATUS\_MASK Register Field Descriptions**

Bit	Field	Type	Reset	Description
15-8	RESERVED	R	FFh	
7	SR_BUSYn	R/W	1h	Slew Rate Not Busy Mask 0h = Fault asserts IRQ 1h = The mask prevents IRQ or Alarm being triggered (default). The status is always set if the condition exists.
6	ADC_EOC	R/W	1h	ADC End Of Conversion Mask Same as Slew Rate Not Busy Mask (default 1h).
5-4	RESERVED	R	3h	
3	BREAK_FRAME_ERR	R/W	1h	Break Frame Error Fault Mask Same as Slew Rate Not Busy Mask (default 1h).
2	BREAK_PARITY_ERR	R/W	1h	Break Parity Error Fault Mask Same as Slew Rate Not Busy Mask (default 1h).
1	UART_FRAME_ERR	R/W	1h	UART Frame Error Fault Mask Same as Slew Rate Not Busy Mask (default 1h).
0	UART_PARITY_ERR	R/W	1h	UART Parity Error Fault Mask Same as Slew Rate Not Busy Mask (default 1h).

### 7.6.1.21 ALARM\_STATUS Register (Offset = 20h) [Reset = 0200h]

Return to the [Register Map](#).

**表 7-32. ALARM\_STATUS Register Field Descriptions**

Bit	Field	Type	Reset	Description
15	GEN_IRQ	R	0h	General IRQ OR of all the unmasked bits in the GEN_STATUS register. 0h = All of the unmasked bits of the GEN_STATUS register are low 1h = At least one of the unmasked bits in the GEN_STATUS register is high
14	RESERVED	R	0h	
13	SD_FLT	R	0h	Self Diagnostic (SD) Fault 0h = All self diagnostic channels are within threshold limits 1h = At least one of the self diagnostic channels has failed
12	OSC_FAIL	R	0h	Oscillator Fault Oscillator failed to start. This bit holds $\overline{\text{ALARM}}$ low and does not feed IRQ. 0h = Oscillator started; 1h = Oscillator has failed to start
11-10	CRC_CNT	R	0h	CRC Fault Counter If counter limit $\leq 4$ then bits[1:0] of the counter are shown here. If the counter limit = 8 then bits[2:1] of the counter are shown.
9	OTP_LOADEDn	R	1h	OTP NOT Loaded Clears when OTP has loaded at least once. Keeps $\overline{\text{ALARM}}$ asserted until OTP finishes loading. Does not feed IRQ. 0h = OTP has loaded at least once; 1h = OTP has not finished loading
8	OTP_CRC_ERR	R	0h	OTP CRC Error Maskable fault. An error occurred with the OTP CRC calculation. Sticky, cleared by reading register, unless condition still persist. 0h = No OTP CRC fault; 1h = OTP CRC fault
7	CRC_FLT	R	0h	CRC Fault Maskable fault. Invalid CRC value transmitted during SPI frame. Sticky, cleared by reading register, unless condition still persist. 0h = No CRC fault; 1h = CRC fault
6	WD_FLT	R	0h	Watchdog Timer Fault Maskable fault. Sticky, cleared by reading register, unless condition still persist. 0h = No watchdog fault; 1h = Watchdog fault
5	VREF_FLT	R	0h	Invalid Reference Voltage Maskable fault. OR with FORCE_FAIL.VREF_FLT bit. Active signal, set as long as condition is true. Direct input from analog circuit. 0h = Valid VREF voltage; 1h = Invalid VREF voltage
4	ADC_AIN1_FLT	R	0h	ADC AIN1 Fault. Maskable fault. 0h = AIN1 ADC measurement within threshold limits 1h = AIN1 ADC measurement outside threshold limits
3	ADC_AIN0_FLT	R	0h	ADC AIN0 Fault. Maskable fault. 0h = AIN0 ADC measurement within threshold limits 1h = AIN0 ADC measurement outside threshold limits
2	ADC_TEMP_FLT	R	0h	ADC Temp Fault. Maskable fault. 0h = TEMP ADC measurement within threshold limits 1h = TEMP ADC measurement outside threshold limits
1	THERM_ERR_FLT	R	0h	Temperature > 130°C error. Maskable fault. OR with FORCE_FAIL.THERM_ERR_FLT bit. Active signal, set as long as condition is true. Direct input from analog circuit. 0h = Temperature $\leq 130^\circ\text{C}$ ; 1h = Temperature > 130°C
0	THERM_WARN_FLT	R	0h	Temperature > 85°C warning. Maskable fault. OR with FORCE_FAIL.THERM_WARN_FLT bit. Active signal, set as long as condition is true. Direct input from analog circuit. 0h = Temperature $\leq 85^\circ\text{C}$ ; 1h = Temperature > 85°C

### 7.6.1.22 GEN\_STATUS Register (Offset = 21h) [Reset = 1180h]

Return to the [Register Map](#).

**表 7-33. GEN\_STATUS Register Field Descriptions**

Bit	Field	Type	Reset	Description
15	ALARM_IRQ	R	0h	Alarm IRQ OR of all the unmasked bits in the ALARM_STATUS register. 0h = All of the unmasked bits of the ALARM_STATUS register are low 1h = At least one of the unmasked bits in the ALARM_STATUS register is high
14-13	RESERVED	R	0h	
12	OTP_BUSY	R	1h	OTP Busy Status = 1h at power up while the OTP is being loaded into the trim latches. 0h = OTP has completed loading into the device 1h = OTP is being loaded into the device
11	RESERVED	R	0h	
11-9	RESERVED	R	0h	
8	RESET	R	1h	Device Reset Occurred. Status only. Does not feed IRQ. Sticky, cleared by reading register, unless condition still persist. 0h = Device has not reset since last read of register 1h = Device has reset since last read of register
7	SR_BUSYn	R	1h	Slew Rate Not Busy. Maskable fault. 0h = DAC is slewing to the target code 1h = DAC_OUT has reached the DAC_DATA. If slew rate is disabled, then this signal produces a rising edge within 3 internal clock cycles. If slew rate is enabled, this signal creates an IRQ event when the DAC_OUT has reached the DAC_DATA. At this time, slew rate can be safely disabled. If slew rate is disabled prior to DAC_OUT = DAC_DATA then a jump of DAC_OUT occurs. This can cause an unwanted fast transition on VOUT.
6	ADC_EOC	R	0h	ADC End of Conversion (EOC). Maskable fault. Sticky, cleared by reading register, unless condition still persist. 0h = No EOC since last read of register; 1h = ADC end of conversion
5	ADC_BUSY	R	0h	ADC Busy. Status only. Does not feed IRQ. Active signal, set as long as condition is true. 0h = No ADC activity; 1h = ADC is actively converting
4	PVDD_HI	R	0h	PVDD High. Status only. Does not feed IRQ. Set as long as condition is true. 0h = PVDD < 2.7 V; 1h = PVDD ≥ 2.7V
3	BREAK_FRAME_ERR	R	0h	Incorrect Stop Bit During Break Character. Maskable fault. Applies to UARTIN. Sticky, cleared by reading register, unless condition still persist. 0h = No break frame error; 1h = Break frame error
2	BREAK_PARITY_ERR	R	0h	Incorrect parity (ODD) bit during break character. Maskable fault. Applies to UARTIN. Sticky, cleared by reading register, unless condition still persist. 0h = No break parity error; 1h = Break parity error
1	UART_FRAME_ERR	R	0h	Incorrect stop bit during UART character. Maskable fault. Applies to UARTIN. Sticky, cleared by reading register, unless condition still persist. 0h = No UART frame error; 1h = UART frame error
0	UART_PARITY_ERR	R	0h	Incorrect parity (ODD) bit during UART character. Maskable fault. Applies to UARTIN. Sticky, cleared by reading register, unless condition still persist. 0h = No UART parity error; 1h = UART parity error

### 7.6.1.23 ADC\_FLAGS Register (Offset = 23h) [Reset = 0000h]

Return to the [Register Map](#).

The limits for Self Diagnostic (SD) Alarm ADC Thresholds are shown in [表 7-7](#).

表 7-34. ADC\_FLAGS Register Field Descriptions

Bit	Field	Type	Reset	Description
15-9	RESERVED	R	0h	
8	SD4_FAIL	R	0h	SD4 (VOUT) Limit Fail
7	SD3_FAIL	R	0h	SD3 (ZTAT) Limit Fail
6	SD2_FAIL	R	0h	SD2 (VDD) Limit Fail
5	SD1_FAIL	R	0h	SD1 (PVDD) Limit Fail
4	SD0_FAIL	R	0h	SD0 (VREF) Limit Fail
3	TEMP_FAIL	R	0h	TEMP Limit Fail
2	AIN1_FAIL	R	0h	AIN1 Limit Fail
1	AIN0_FAIL	R	0h	AIN0 Limit Fail
0	RESERVED	R	0h	

### 7.6.1.24 ADC\_AIN0 Register (Offset = 24h) [Reset = 0000h]

Return to the [Register Map](#).

表 7-35. ADC\_AIN0 Register Field Descriptions

Bit	Field	Type	Reset	Description
15-12	RESERVED	R	0h	
11-0	DATA	R	0h	Converted Value of Voltage on Pin AIN0

### 7.6.1.25 ADC\_AIN1 Register (Offset = 25h) [Reset = 0000h]

Return to the [Register Map](#).

表 7-36. ADC\_AIN1 Register Field Descriptions

Bit	Field	Type	Reset	Description
15-12	RESERVED	R	0h	
11-0	DATA	R	0h	Converted Value of Voltage on Pin AIN1

### 7.6.1.26 ADC\_TEMP Register (Offset = 26h) [Reset = 0000h]

Return to the [Register Map](#).

表 7-37. ADC\_TEMP Register Field Descriptions

Bit	Field	Type	Reset	Description
15-12	RESERVED	R	0h	
11-0	DATA	R	0h	Converted Value of Temperature

### 7.6.1.27 ADC\_SD\_MUX Register (Offset = 27h) [Reset = 0000h]

Return to the [Register Map](#).

**表 7-38. ADC\_SD\_MUX Register Field Descriptions**

Bit	Field	Type	Reset	Description
15-12	RESERVED	R	0h	
11-0	DATA	R	0h	Converted Value of Voltage on Self-Diagnostic (SD) MUX Input

### 7.6.1.28 ADC\_OFFSET Register (Offset = 28h) [Reset = 0000h]

Return to the [Register Map](#).

**表 7-39. ADC\_OFFSET Register Field Descriptions**

Bit	Field	Type	Reset	Description
15-12	RESERVED	R	0h	
11-0	DATA	R	0h	ADC Comparator Offset This value reports the offset measured in the device, and can be used to adjust each conversion value. If ADC_BYP.OFST_BYP_EN is set, then the value in ADC_BYP.DATA is used as the offset. This value is not affected by ADC_BYP.

### 7.6.1.29 DAC\_OUT Register (Offset = 2Ch) [Reset = 0000h]

Return to the [Register Map](#).

**表 7-40. DAC\_OUT Register Field Descriptions**

Bit	Field	Type	Reset	Description
15-0	DATA	R	0h	DAC Code Applied to the Analog Circuit

### 7.6.1.30 ADC\_OUT Register (Offset = 2Dh) [Reset = 0000h]

Return to the [Register Map](#).

表 7-41. ADC\_OUT Register Field Descriptions

Bit	Field	Type	Reset	Description
15-12	RESERVED	R	0h	
11-0	DATA	R	0h	ADC Data for Each Conversion Does not include ADC_OFFSET.DATA adjustment. Is not affected by ADC_BYP.DATA.

### 7.6.1.31 ADC\_BYP Register (Offset = 2Eh) [Reset = 0000h]

ADC\_BYP is shown in [ADC\\_BYP Register Field Descriptions](#).

Return to the [Register Map](#).

表 7-42. ADC\_BYP Register Field Descriptions

Bit	Field	Type	Reset	Description
15	DATA_BYP_EN	R/W	0h	Data Bypass Enable Applies ADC_BYP.DATA to the ADC channel being converted. ADC_OFFSET is ignored. Do not set OFST_BYP_EN and DATA_BYP_EN at the same time. If OFST_BYP_EN is also set, OFST_BYP_EN takes priority over DATA_BYP_EN. In this case, ADC_BYP.DATA is used for the ADC_OFFSET register, and DATA_BYP_EN is forced to 0. After a channel is converted, the ADC_BYP.DATA value appears in the readback register and is used to calculate faults. 0h = Data bypass disabled (default) 1h = Data bypass enabled
14	OFST_BYP_EN	R/W	0h	Offset Bypass Enable Overrides the offset register with the ADC_BYP.DATA value. When using this bit, the ADC_BYP.DATA field is processed as 2's complement. Do not set OFST_BYP_EN and DATA_BYP_EN at the same time. 0h = Offset bypass disabled (default) 1h = Offset bypass enabled
13	DIS_GND_SAMP	R/W	0h	Disable GND Sampling This bit disables the sampling of GND during SAR activity. The sampling of GND is used to fully discharge the sampling CAP to reduce channel crosstalk. 0h = GND sampling enabled (default) 1h = GND sampling disabled
12	RESERVED	R	0h	
11-0	DATA	R/W	0h	Bypass Data

### 7.6.1.32 FORCE\_FAIL Register (Offset = 2Fh) [Reset = 0000h]

Return to the [Register Map](#).

Force failures for fault detection.

**表 7-43. FORCE\_FAIL Register Field Descriptions**

Bit	Field	Type	Reset	Description
15	CRC_FLT	R/W	0h	Force CRC Failure on SDO by Inverting the CRC Byte 0h = No force failure of CRC (default) 1h = Force failure of CRC
14	VREF_FLT	R/W	0h	Force Reference Voltage Failure. Analog signal. 0h = No force failure of VREF (default) 1h = Force failure of VREF
13	THERM_ERR_FLT	R/W	0h	Force Temperature > 130°C Thermal Error. Analog signal. 0h = No force temperature > 130°C error (default) 1h = Force temperature > 130°C error
12	THERM_WARN_FLT	R/W	0h	Force Temperature > 85°C thermal Warning. Analog signal. 0h = No force temperature > 85°C warning (default) 1h = Force temperature > 85°C warning
11-10	RESERVED	R/W	0h	
9	SD4_HI_FLT	R/W	0h	SD4 (VOUT) High Limit Failure. ADC measurement. 0h = No force failure of SD4 (VOUT) (default) 1h = Force failure of SD4 (VOUT)
8	SD4_LO_FLT	R/W	0h	SD4 (VOUT) Low limit failure. ADC measurement. 0h = No force failure of SD4 (VOUT) (default) 1h = Force failure of SD4 (VOUT)
7	SD3_HI_FLT	R/W	0h	SD3 (ZTAT) High Limit Failure. ADC measurement. 0h = No force failure of SD3 (ZTAT) (default) 1h = Force failure of SD3 (ZTAT)
6	SD3_LO_FLT	R/W	0h	SD3 (ZTAT) Low Limit Failure. ADC measurement. 0h = No force failure of SD3 (ZTAT) (default) 1h = Force failure of SD3 (ZTAT)
5	SD2_HI_FLT	R/W	0h	SD2 (VDD) High Limit Failure. ADC measurement. 0h = No force failure of SD2 (VDD) (default) 1h = Force failure of SD2 (VDD)
4	SD2_LO_FLT	R/W	0h	SD2 (VDD) Low Limit Failure. ADC measurement. 0h = No force failure of SD2 (VDD) (default) 1h = Force failure of SD2 (VDD)
3	SD1_HI_FLT	R/W	0h	SD1 (PVDD) High Limit Failure. ADC measurement. 0h = No force failure of SD1 (PVDD) (default) 1h = Force failure of SD1 (PVDD)
2	SD1_LO_FLT	R/W	0h	SD1 (PVDD) Low Limit Failure. ADC measurement. 0h = No force failure of SD1 (PVDD) (default) 1h = Force failure of SD1 (PVDD)
1	SD0_HI_FLT	R/W	0h	SD0 (VREF) High Limit Failure. ADC measurement. 0h = No force failure of SD0 (VREF) (default) 1h = Force failure of SD0 (VREF)
0	SD0_LO_FLT	R/W	0h	SD0 (VREF) Low Limit Failure. ADC measurement. 0h = No force failure of SD0 (VREF) (default) 1h = Force failure of SD0 (VREF)

## 8 Application and Implementation

### 备注

以下应用部分中的信息不属于 TI 器件规格的范围，TI 不担保其准确性和完整性。TI 的客户应负责确定器件是否适用于其应用。客户应验证并测试其设计，以确保系统功能。

### 8.1 Application Information

The AFEx8101 are extremely low-power 16-bit and 14-bit voltage output DACs. The DACs support a low output range of 0.15 V to 1.25 V or a high output range of 0.3 V to 2.5 V. These devices have an onboard oscillator and an optional precision internal reference. Use these output values with a voltage-to-current (V-to-I) converter stage for 4-mA to 20-mA, loop-powered applications. These devices also feature a SAR ADC that is used to measure internal and external nodes for making diagnostic measurements with fault detection and alarm actions. Use these diagnostic measurements together with the CRC and watchdog timer monitoring for device and system monitoring for functional safety.

The AFEx8101 can operate using extremely low power with 1.8-V supplies. For low-voltage operation, use PVDD with a 1.8-V nominal supply and an operating range of 1.71 V to 1.89 V. Run the digital interface supply, IOVDD, from 1.71 V to 5.5 V. During low-voltage operation, the VDD LDO is automatically disabled and VDD is tied to PVDD. Low-voltage operation allows for both lower power for field transmitter applications and better voltage compliance when there are high resistances in the loop.

With higher-supply operation, the PVDD has an operating range of 2.7 V to 5.5 V. With this range of operation, the VDD is powered from an onboard LDO.

#### 8.1.1 Multichannel Configuration

Because  $\overline{CS}$  low is required for communication and SDO can be set to a tri-state condition, only individual  $\overline{CS}$  signals are required from the microcontroller for all the AFEx8101 devices in the system. The SDI, SDO, and SCLK signals can be combined. All the individual  $\overline{ALARM}$  pins can be wired-OR together. This minimizes the number of microcontroller GPIO signals required for communication, as well as the number of isolation channels for isolated systems. The multichannel configuration block diagram is shown in [图 8-1](#).



图 8-1. Multichannel Configuration



## 8.2 Typical Application

This design example shows a loop-powered, 4-mA to 20-mA field transmitter featuring the AFE88101. The AFE78101 can also be used in this design for lower-resolution applications.

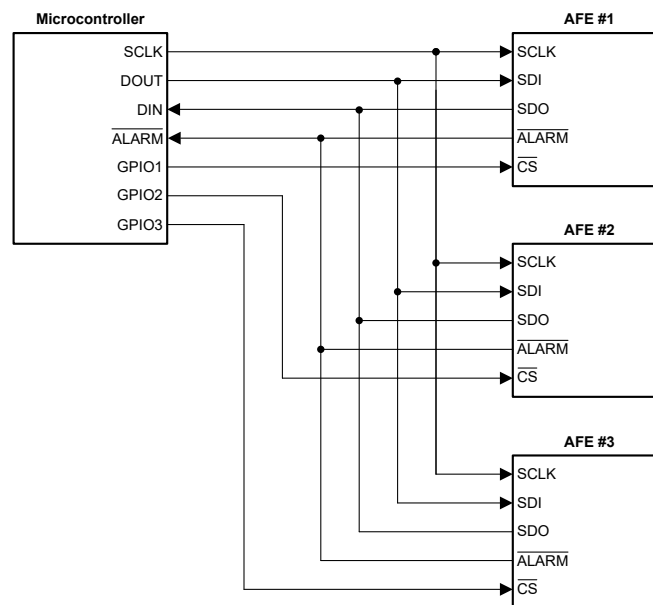
This design example combines several circuit elements to create a subsystem that can support most field sensors in two-wire, current-loop applications. The design accepts bus voltages from 12 V to 36 V, while regulating the loop-current representation of a sensor to a post-calibration accuracy of less than 0.1% full-scale range (FSR) of total error at room temperature. The high integration in the system allows for a compact circuit, making this device an excellent choice for field transmitters where space is a concern. In field-transmitter applications, the current-loop transmitter, microcontroller, sensors, and analog front end are all required to consume less than the minimum bus current of 3 mA. Use an integrated DC/DC converter in the system to extend the current budget and allow more current for sensors and the AFE.

 8-2 shows the schematic diagram for the loop-powered, 4-mA to 20-mA field transmitter.

### 8.2.1 4-mA to 20-mA Current Transmitter



图 8-2. AFE88101 in a 4-mA to 20-mA Current Transmitter

### 8.2.1.1 Design Requirements

The design requirements are:

- Transmitter with a current output range of 4 mA to 20 mA for a process variable signal
- Out-of-range current output capability from 3 mA to 25 mA for error or fault signal levels
- Operation with standard industrial automation supply voltages from 12 V to 30 V
- Current and voltage outputs with TUE less than 0.5% at 25°C
- Total on-board current must be less than or equal to 3 mA

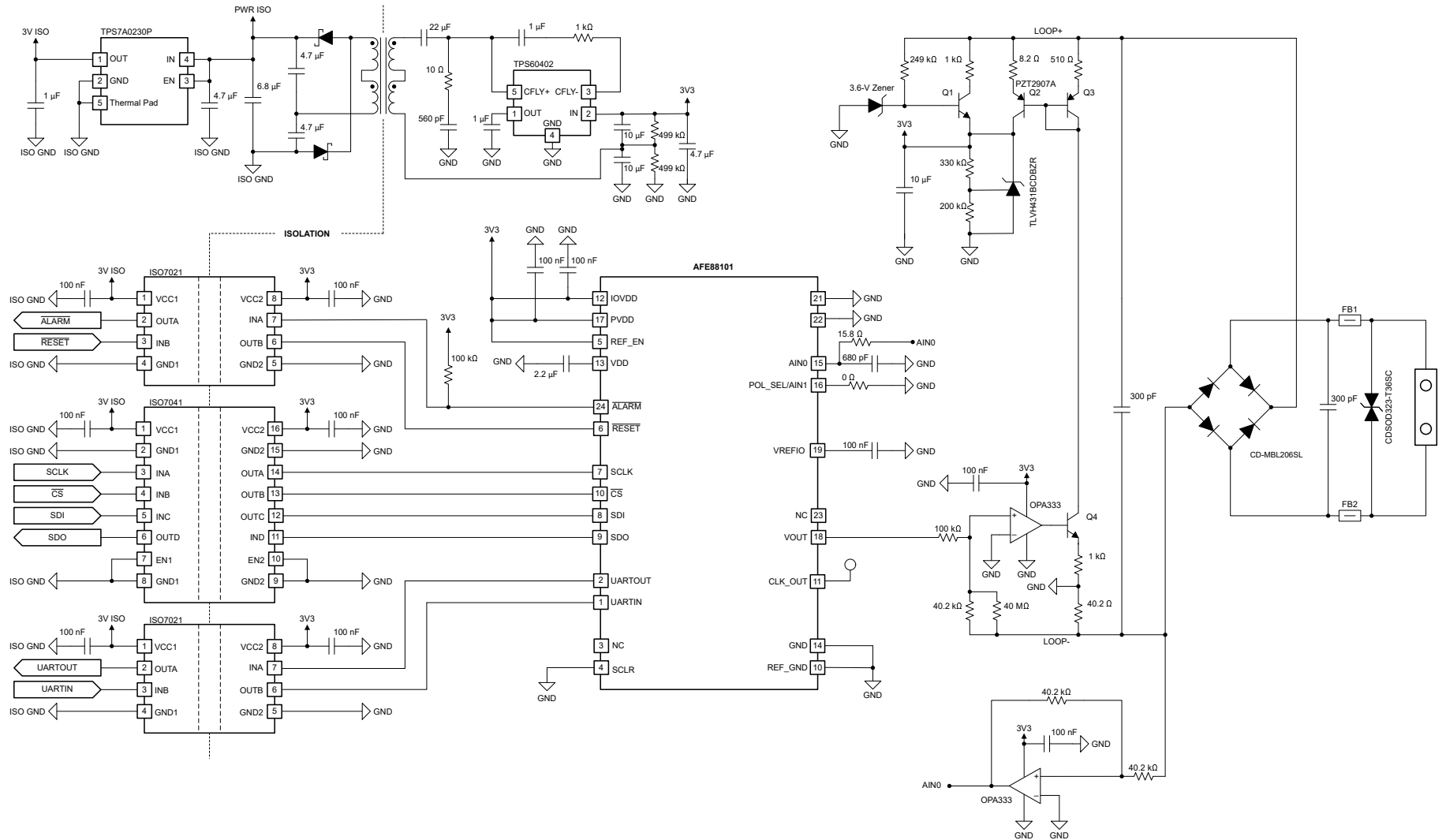
### 8.2.1.2 Detailed Design Procedure

图 8-3 shows a block diagram of a loop-powered, 4-mA to 20-mA current transmitter.



图 8-3. Block Diagram of a Loop-Powered, 4-mA to 20-mA Current Transmitter

The terminals connected to the loop are shown on the right side of the block diagram. This connection to the loop powers the entire transmitter. A bridge rectifier at the input protects against reverse connection to the loop. The rectified loop voltage powers a start-up circuit that provides power to an LDO, that in turn powers the AFE88101. The LDO powers a flyback converter acting as a boost and supplies power across an isolation barrier. On the other side of the isolation barrier, another LDO powers the MCU and any sensor connected to the transmitter. The LDOs also power the digital signal isolation on each side of the barrier.

The AFE88101 controls the loop current through the voltage-to-current (V-to-I) converter block. The DAC voltage sets the output from 0.3 V to 2.5 V. The output is sent through a V-to-I converter block using an [OPA333](#) and an NPN bipolar junction transistor (BJT).

### 8.2.1.2.1 Start-Up Circuit

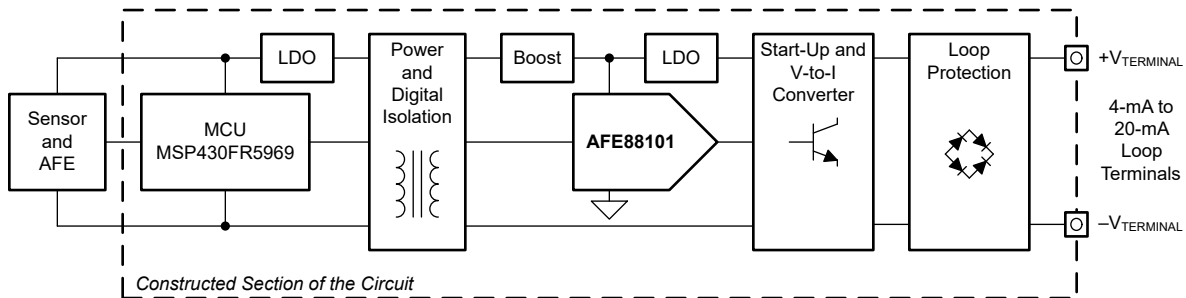
When the loop is applied to the terminals, the loop power starts up the board. Transistor Q4 from [图 8-2](#) pulls current from the start-up and current-shunt regulator sections of the transmitter. The start-up circuit is shown in [图 8-4](#).

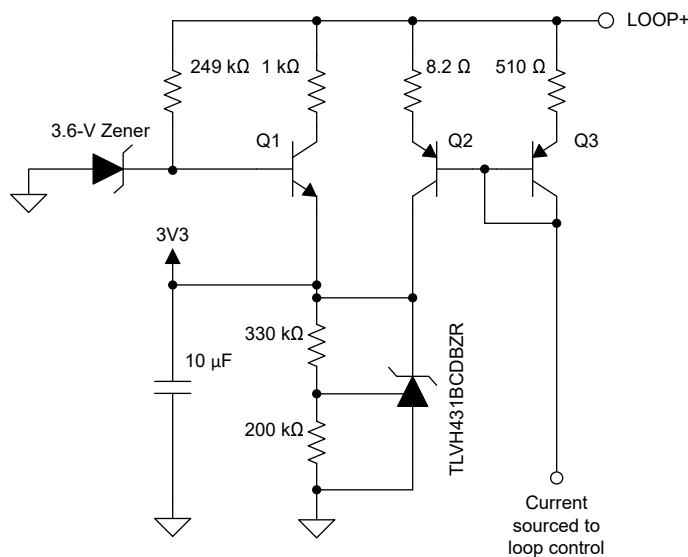

**图 8-4. Start-Up Circuit**

In the start-up circuit, the 3.6-V Zener diode sets the voltage at the base of Q1. If the TLVH431B shunt regulator has not started, apply voltage to LOOP+ and LOOP- to turn on Q1 and source current to the shunt regulator. As the shunt regulator turns on and approaches the set voltage of 3.3 V, the base-emitter voltage ( $V_{BE}$ ) of Q1 becomes smaller. The collector current of Q2 drives the current of the shunt regulator to set the LOOP current going through the 40.2- $\Omega$  resistor in the current loop control circuit shown in the following section. After the start-up circuit has started, Q1 stops supplying current because the  $V_{BE}$  is restricted. Q1 shuts off, leaving several microamps of current flowing through the 3.6-V Zener diode.

Take care when selecting the Zener diode. The voltage across the Zener diode varies with the loop voltage and the temperature of the circuit. This variance can change the  $V_{BE}$  across Q1 and change the total current going through the start-up circuit. If the voltage is too high, the Zener diode sets Q1 to continue to source current after the circuit starts up. If the voltage is too low, the Zener diode prevents the TLVH431B from turning on. Verify proper start up by checking that the 3.3-V supply starts up, and that Q1 turns off when in operation.

When the circuit starts up and the 3V3 line comes up to the desired 3.3-V supply level, the current through the TLVH431B is primarily sourced through Q2. The Q2 transistor must be able to dissipate enough power to handle the high current (> 20 mA) and the high voltage (> 30 V) in the loop. Because the biased transistor, Q2, is responsible for sourcing most of the output current, choose the components in the path of this current flow with appropriate power ratings. In this case, the 8.2- $\Omega$  resistor is rated to 0.25 W.

The current mirror is set up so that the current gain from Q3 to Q2 is approximately a factor of 60  $\times$ . The exact current gain is not important as long as the current through Q3 is low.

### 8.2.1.2.2 Current Loop Control

The AFE88101 sets an output voltage from 0.3 V to 2.5 V if configured in Range 0 with PVDD > 2.7 V. 图 8-5 shows the feedback circuit that sets the loop current from the DAC output voltage.



图 8-5. Current Loop Control for the AFE88101 Transmitter

In this circuit, the VOUT voltage is set across the 100-kΩ resistor by the AFE88101. The opposite end of the 100-kΩ resistor is set to ground by the feedback of the OPA333. The current across the 100-kΩ resistor is VOUT divided by 100 kΩ. This current continues through the 40.2-kΩ resistor so that the voltage at LOOP - is less than ground. 方程式 11 calculates the voltage at LOOP - .

$$V_{\text{LOOP-}} = - (V_{\text{OUT}} / 100 \text{ k}\Omega) \times 40.2 \text{ k}\Omega = - V_{\text{OUT}} \times 0.402 \quad (11)$$

When the DAC output voltage is set to 0.3 V, the voltage at LOOP - is 0.1206 V less than ground. When the DAC output voltage is set to 2.5 V, the voltage at LOOP - is 1.005 V less than ground. The LOOP - voltage sets the loop current that flows from ground to LOOP - through the 40.2-Ω resistor. This current is sourced from ground but controlled by the current sunk from Q4 coming from the start-up circuit. 方程式 12 calculates the loop current.

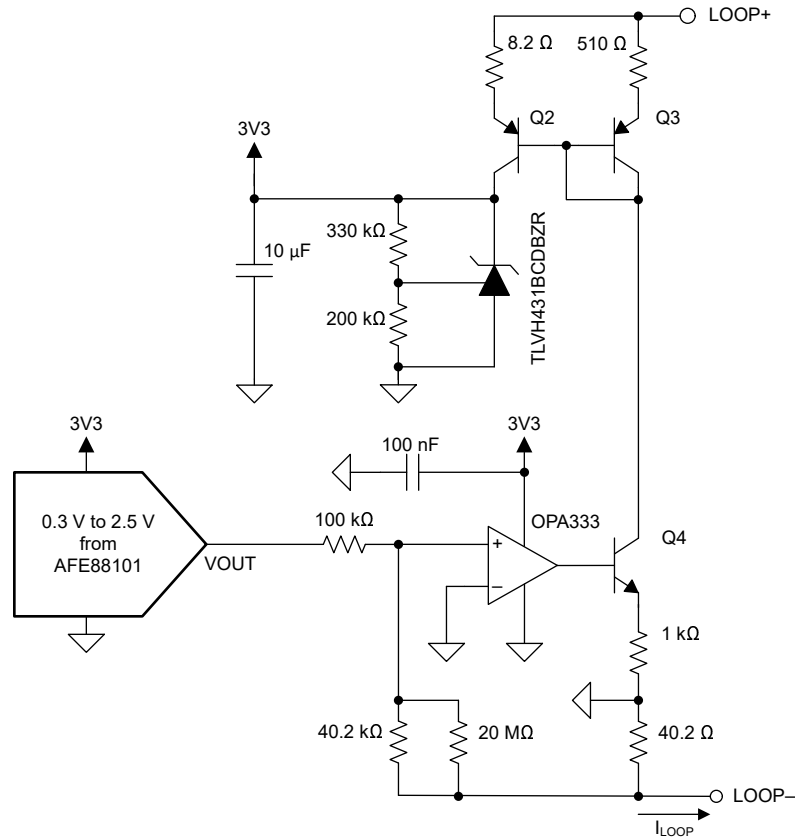
$$I_{\text{LOOP}} = - V_{\text{LOOP-}} / 40.2 \text{ k}\Omega \quad (12)$$

Substituting 方程式 12 into 方程式 11, 方程式 13 is obtained.

$$I_{\text{LOOP}} = V_{\text{OUT}} \times 0.402 / 40.2 \Omega = V_{\text{OUT}} / 100 \Omega \quad (13)$$

When the DAC output voltage is set to 0.3 V, the loop current is 3 mA. When the DAC output voltage is set to 2.5 V, the loop current is 25 mA. The OPA333 drives the base of transistor Q4 to pull the correct amount of

current to set the feedback loop. The current pulled from LOOP+ powers the board. Excess current greater than what is required to power the board is shunted through the TLVH431B regulator.

The AFE88101 sets the DAC output voltage through an output code. This conversion to output voltage is set through [方程式 1](#);  $V_{MIN} = 0.3\text{ V}$  and  $FSR = 2.2\text{ V}$ , resulting in [方程式 14](#).

$$V_{OUT} = \frac{DAC\_CODE}{2^{16}} \times 2.2\text{ V} + 0.3\text{ V} \quad (14)$$

In 4-mA to 20-mA systems, the nominal output operates from 4 mA as the low output and 20 mA as the high output. However, systems sometimes use current outputs that are outside this range to indicate different error conditions. Loop currents of 3.375 mA and 21.75 mA can be used to indicate different loop errors. [表 8-1](#) shows different loop output currents, along with the DAC code and voltages used.

**表 8-1. DAC Voltage Output and Loop Current Based on DAC Output Codes**

OUTPUT CONDITION	DAC CODE	DAC OUTPUT (V)	LOOP CURRENT (mA)
DAC minimum	0x0000	0.3	3
Error low	0x045D	0.3375	3.375
In-range minimum	0x0BA2	0.4	4
In-range midscale	0x68BA	1.2	12
In-range maximum	0xC5D1	2.0	20
Error high	0xDA2E	2.175	21.75
DAC maximum	0xFFFF	2.5	25

Among the passive devices included in the design, choose gain setting resistors that exhibit tight tolerances to achieve high accuracy. These resistors are primarily responsible for setting the gain of the current loop, along with primary path of the output current flow.

### 8.2.1.2.3 Input Protection and Rectification

[图 8-6](#) shows the simple protection scheme implemented in the design to mitigate issues that arise from voltage and current transients on the bus. These transients have two main components: high-frequency and high-energy. These two components can be leveraged with a strategy of attenuation and diversion by the protection circuitry to deliver robust immunity.

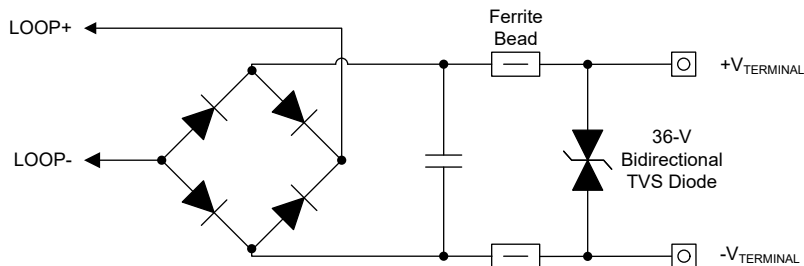

**图 8-6. Loop Input Protection**

Attenuation uses passive components, primarily resistors and capacitors, to attenuate high-frequency transients and to limit series current. Use ferrite beads to maintain dc accuracy while still delivering the ability to limit current from high-frequency transients. This circuit uses a capacitor placed across the input terminals, as well as ferrite beads in series with the terminals.

Diversion capitalizes on the high-voltage properties of the transient signals by using a diode to clamp the transient within supply voltages, or to divert the energy away from the system. Transient voltage suppressor (TVS) diodes help protect against transients because TVS diodes break down very quickly and often feature high power ratings that are critical to survive multiple transient strikes.

A rectifier is also implemented for reverse polarity protection so that the design can be connected to the bus regardless of the pin orientation or polarity without damage to the design.

#### 8.2.1.2.4 System Current Budget

Power consumption is an important consideration when designing two-wire transmitters. Power supplied from the loop must power all the circuitry related to the transmitter and sensor. The minimum loop current in two-wire applications is typically 4 mA. However, for error indications, this current is as low as 3.375 mA. Therefore, the power budget of all transducer circuitry must be less than the maximum allowable system power budget of 3 mA. 表 8-2 lists the specified maximum quiescent current of all included active components (provided from the respective data sheets).

表 8-2. Typical Component Currents

DEVICE	DESCRIPTION	TYPICAL CURRENT ( $\mu$ A)
TPS7A0230	LDO	0.025
AFE88101	16-bit DAC	170
OPA333 (2)	Operational amplifier	17
TLVH431B	Shunt regulator	60
MSP430	Microcontroller	Dependent on firmware
ISO7021D (2), ISO7041F	Digital isolation	Dependent on communications

#### 8.2.1.3 Application Curves



图 8-7. Circuit Start-Up

### 8.3 Initialization Set Up

This section describes several recommendations to set up the AFEx8101.

The AFEx8101 power up with the CRC enabled. If the device is intended to be run without the CRC, the CRC must be disabled by setting the CRC\_EN bit to 0h in the CONFIG register. Be aware that the command to write to this register is first done with the CRC enabled. The CRC byte must be appended to the command for the device to interpret the command correctly. To disable the CRC after start up, write 0x02 0x00 0x26 0x24 to the device. The first three bytes write the command, while the last byte is the CRC byte. For more information on the CRC, see the communication description in 节 7.5.2.3.

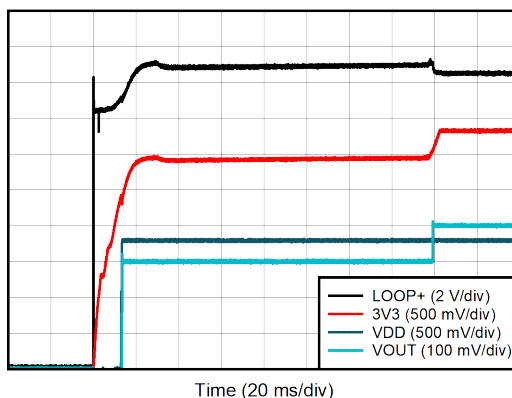
The AFEx8101 also power up with the SDO pin disabled. The SDO is required for reading from any of the device registers, as well as reading any data from the ADC in SPI mode. The SDO is enabled by writing 0h into the DSDO bit in the CONFIG register. See also 节 7.5.2.1 and 节 7.5.2.2.

To enable the ADC, first enable the ADC buffer by writing 0h into the BUF\_PD bit in the ADC\_CFG register. Information about using the ADC in different modes of operation is in 节 7.3.2.

## 8.4 Power Supply Recommendations

The AFEx8101 can operate within a single-supply range of 2.7 V to 5.5 V applied to the PVDD pin. When 2.7 V to 5.5 V is provided to PVDD, an internal LDO is enabled that drives VDD internally. VDD pin must have 1  $\mu$ F to 10  $\mu$ F of capacitance for operation.

The AFEx8101 can also be operated with a lower supply voltage of 1.71 V to 1.89 V applied to the PVDD pin. When the voltage is within this lower range, the internal LDO is not operational, and the lower external supply on the PVDD pin must be tied to the VDD pin.

The digital interface supply, IOVDD, can operate with a supply range of 1.71 V to 5.5 V.

Switching power supplies and DC/DC converters often have high-frequency glitches or spikes riding on the output voltage. In addition, digital components can create similar high-frequency spikes. This noise can easily couple into the DAC output voltage or current through various paths between the power connections and analog output. To further reduce noise, include bulk and local decoupling capacitors. The current consumption on the PVDD and IOVDD pins, the short-circuit current limit for the voltage output, and the current ranges for the current output are listed in the [Electrical Characteristics](#). The power supply must meet the requirements listed in the [Recommended Operating Conditions](#).

## 8.5 Layout

### 8.5.1 Layout Guidelines

To maximize the performance of the AFEx8101 in any application, follow good layout practices and proper circuit design. The following recommendations are specific to the device:

- For best performance, dedicate an entire PCB layer to a ground plane and do not route any other signal traces on this layer. However, depending on restrictions imposed by specific end equipment, a dedicated ground plane is not always practical. If ground-plane separation is necessary, make a direct connection of the planes at the DAC. Do not connect individual ground planes at multiple locations because this configuration creates ground loops.
- IOVDD and PVDD must have 100-nF decoupling capacitors local to the respective pins. VDD must have at least a 1- $\mu$ F decoupling capacitor used for the internal LDO, or for an external 1.8-V supply. Use a high-quality ceramic-type NP0 or X7R capacitor for best performance across temperature and a very low dissipation factor.
- Place a 100-nF reference capacitor close to the VREFIO pin.
- Avoid routing switching signals near the reference input.
- Maintain proper placement for the digital and analog sections with respect to the digital and analog components. Separate the analog and digital circuitry for less coupling into neighboring blocks and to minimize the interaction between analog and digital return currents.
- For designs that include protection circuits:
  - Place diversion elements, such as TVS diodes or capacitors, close to off-board connectors to make sure that return current from high-energy transients does not cause damage to sensitive devices
  - Use large, wide traces to provide a low-impedance path to divert high-energy transients away from the I/O pins.



### 8.5.2 Layout Example



图 8-8. Layout Example

## 9 Device and Documentation Support

### 9.1 Documentation Support

#### 9.1.1 Related Documentation

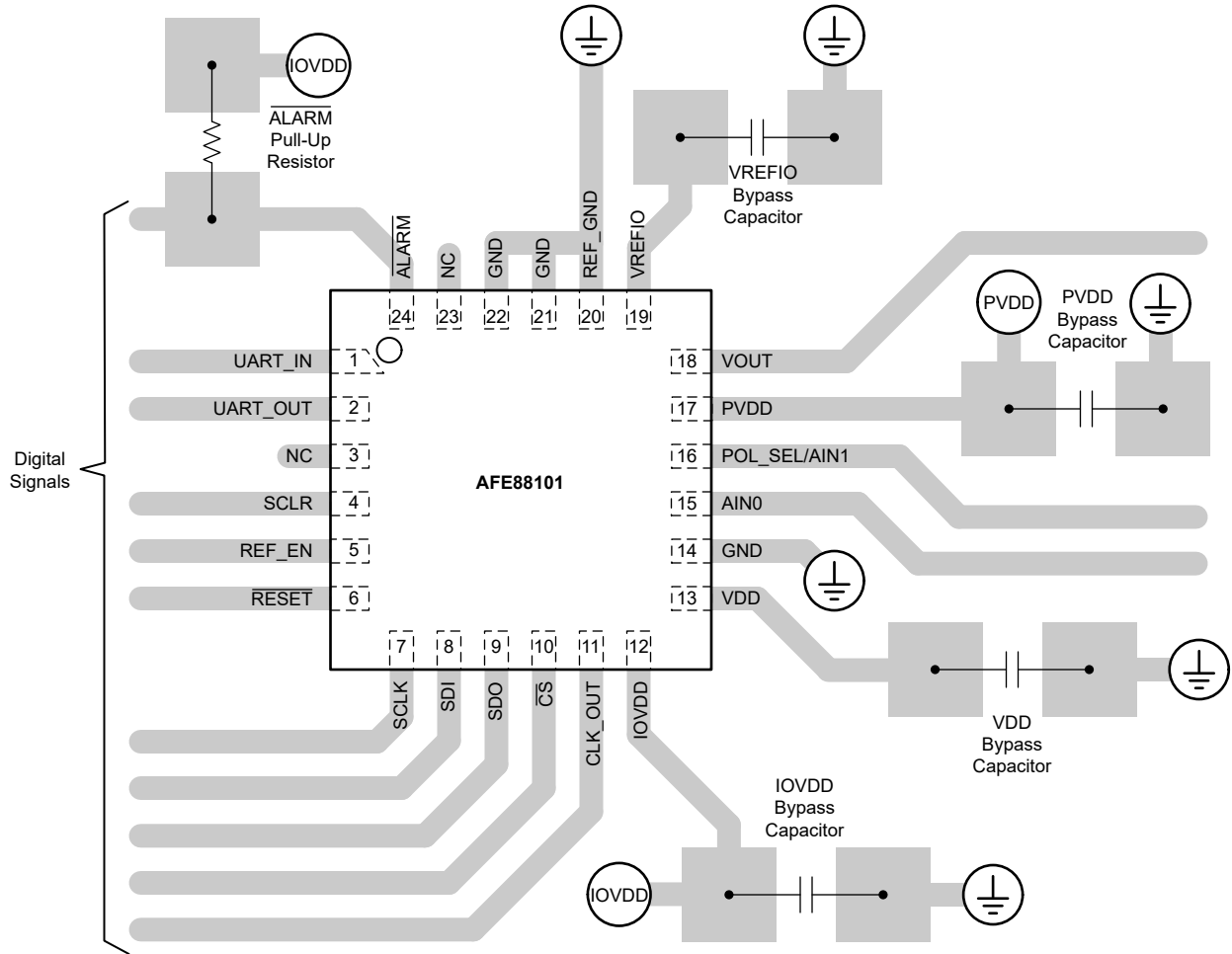
For related documentation see the following:

- Texas Instruments, [AFE881H1 Evaluation Module User's Guide](#)
- Texas Instruments, [REF35 Ultra Low-Power, High-Precision Voltage Reference data sheet](#)
- Texas Instruments, [OPA391 Precision, Ultra-Low IQ, Low Offset Voltage, e-trim™ Op Amp data sheet](#)
- Texas Instruments, [ADS1220 4-Channel, 2-kSPS, Low-Power, 24-Bit ADC with Integrated PGA and Reference data sheet](#)
- Texas Instruments, [TPS7A16 60-V, 5-μA IQ, 100-mA, Low-Dropout Voltage Regulator With Enable and Power-Good data sheet](#)
- Texas Instruments, [TPS7A02 Nanopower IQ, 25-nA, 200-mA, Low-Dropout Voltage Regulator With Fast Transient Response data sheet](#)
- Texas Instruments, [ISO7021 Ultra-Low Power Two-Channel Digital Isolator data sheet](#)
- Texas Instruments, [Isolated, Ultra-Low Power Design for 4- to 20-mA Loop Powered Transmitters design guide](#)
- Texas Instruments, [Isolated Loop Powered Thermocouple Transmitter design guide](#)
- Texas Instruments, [Small Form Factor, 2-Wire, 4- to 20-mA Current-Loop, RTD Temperature Transmitter design guide](#)
- Texas Instruments, [Isolated Power and Data Interface for Low-power Applications reference design](#)
- Texas Instruments, [Uniquely Efficient Isolated DC/DC Converter for Ultra-Low Power and Low-Power Applications design guide](#)

#### 9.2 接收文档更新通知

要接收文档更新通知，请导航至 [ti.com](https://www.ti.com) 上的器件产品文件夹。点击 [订阅更新](#) 进行注册，即可每周接收产品信息更改摘要。有关更改的详细信息，请查看任何已修订文档中包含的修订历史记录。

#### 9.3 支持资源

[TI E2E™ 支持论坛](#) 是工程师的重要参考资料，可直接从专家获得快速、经过验证的解答和设计帮助。搜索现有解答或提出自己的问题可获得所需的快速设计帮助。

链接的内容由各个贡献者“按原样”提供。这些内容并不构成 TI 技术规范，并且不一定反映 TI 的观点；请参阅 TI 的《[使用条款](#)》。

#### 9.4 Trademarks

TI E2E™ is a trademark of Texas Instruments.

所有商标均为其各自所有者的财产。

#### 9.5 Electrostatic Discharge Caution



This integrated circuit can be damaged by ESD. Texas Instruments recommends that all integrated circuits be handled with appropriate precautions. Failure to observe proper handling and installation procedures can cause damage.

ESD damage can range from subtle performance degradation to complete device failure. Precision integrated circuits may be more susceptible to damage because very small parametric changes could cause the device not to meet its published specifications.

#### 9.6 术语表

[TI 术语表](#) 本术语表列出并解释了术语、首字母缩略词和定义。

## 10 Mechanical, Packaging, and Orderable Information

The following pages include mechanical, packaging, and orderable information. This information is the most current data available for the designated devices. This data is subject to change without notice and revision of this document. For browser-based versions of this data sheet, refer to the left-hand navigation.

**PACKAGING INFORMATION**

Orderable Device	Status (1)	Package Type	Package Drawing	Pins	Package Qty	Eco Plan (2)	Lead finish/ Ball material (6)	MSL Peak Temp (3)	Op Temp (°C)	Device Marking (4/5)	Samples
AFE78101RRUR	ACTIVE	UQFN	RRU	24	3000	RoHS & Green	NIPDAU	Level-2-260C-1 YEAR	-55 to 125	AFE 78101	<a href="#">Samples</a>
AFE78101RRUT	ACTIVE	UQFN	RRU	24	250	RoHS & Green	NIPDAU	Level-2-260C-1 YEAR	-55 to 125	AFE 78101	<a href="#">Samples</a>
AFE88101RRUR	ACTIVE	UQFN	RRU	24	3000	RoHS & Green	NIPDAU	Level-2-260C-1 YEAR	-55 to 125	AFE 88101	<a href="#">Samples</a>
AFE88101RRUT	ACTIVE	UQFN	RRU	24	250	RoHS & Green	NIPDAU	Level-2-260C-1 YEAR	-55 to 125	AFE 88101	<a href="#">Samples</a>

(1) The marketing status values are defined as follows:

**ACTIVE:** Product device recommended for new designs.

**LIFEBUY:** TI has announced that the device will be discontinued, and a lifetime-buy period is in effect.

**NRND:** Not recommended for new designs. Device is in production to support existing customers, but TI does not recommend using this part in a new design.

**PREVIEW:** Device has been announced but is not in production. Samples may or may not be available.

**OBSELETE:** TI has discontinued the production of the device.

(2) **RoHS:** TI defines "RoHS" to mean semiconductor products that are compliant with the current EU RoHS requirements for all 10 RoHS substances, including the requirement that RoHS substance do not exceed 0.1% by weight in homogeneous materials. Where designed to be soldered at high temperatures, "RoHS" products are suitable for use in specified lead-free processes. TI may reference these types of products as "Pb-Free".

**RoHS Exempt:** TI defines "RoHS Exempt" to mean products that contain lead but are compliant with EU RoHS pursuant to a specific EU RoHS exemption.

**Green:** TI defines "Green" to mean the content of Chlorine (Cl) and Bromine (Br) based flame retardants meet JS709B low halogen requirements of <=1000ppm threshold. Antimony trioxide based flame retardants must also meet the <=1000ppm threshold requirement.

(3) MSL, Peak Temp. - The Moisture Sensitivity Level rating according to the JEDEC industry standard classifications, and peak solder temperature.

(4) There may be additional marking, which relates to the logo, the lot trace code information, or the environmental category on the device.

(5) Multiple Device Markings will be inside parentheses. Only one Device Marking contained in parentheses and separated by a "~" will appear on a device. If a line is indented then it is a continuation of the previous line and the two combined represent the entire Device Marking for that device.

(6) Lead finish/Ball material - Orderable Devices may have multiple material finish options. Finish options are separated by a vertical ruled line. Lead finish/Ball material values may wrap to two lines if the finish value exceeds the maximum column width.

**Important Information and Disclaimer:**The information provided on this page represents TI's knowledge and belief as of the date that it is provided. TI bases its knowledge and belief on information provided by third parties, and makes no representation or warranty as to the accuracy of such information. Efforts are underway to better integrate information from third parties. TI has taken and

continues to take reasonable steps to provide representative and accurate information but may not have conducted destructive testing or chemical analysis on incoming materials and chemicals. TI and TI suppliers consider certain information to be proprietary, and thus CAS numbers and other limited information may not be available for release.

In no event shall TI's liability arising out of such information exceed the total purchase price of the TI part(s) at issue in this document sold by TI to Customer on an annual basis.

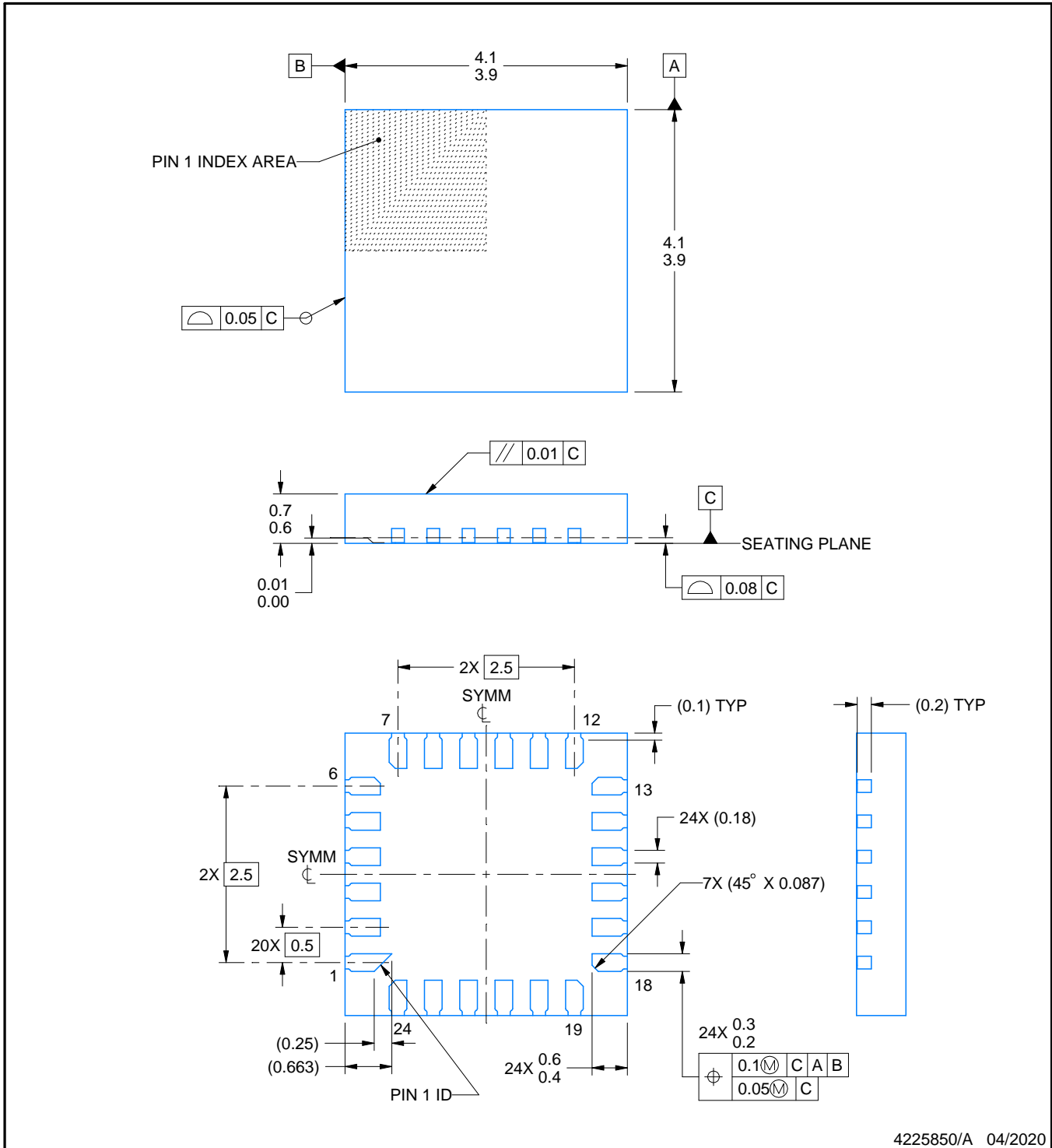
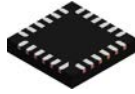

4225850/A 04/2020

NOTES:

1. All linear dimensions are in millimeters. Any dimensions in parenthesis are for reference only. Dimensioning and tolerancing per ASME Y14.5M.
2. This drawing is subject to change without notice.
3. The package thermal pad must be soldered to the printed circuit board for thermal and mechanical performance.

# EXAMPLE BOARD LAYOUT

RRU0024A

UQFN - 0.7 mm max height

PLASTIC QUAD FLATPACK - NO LEAD

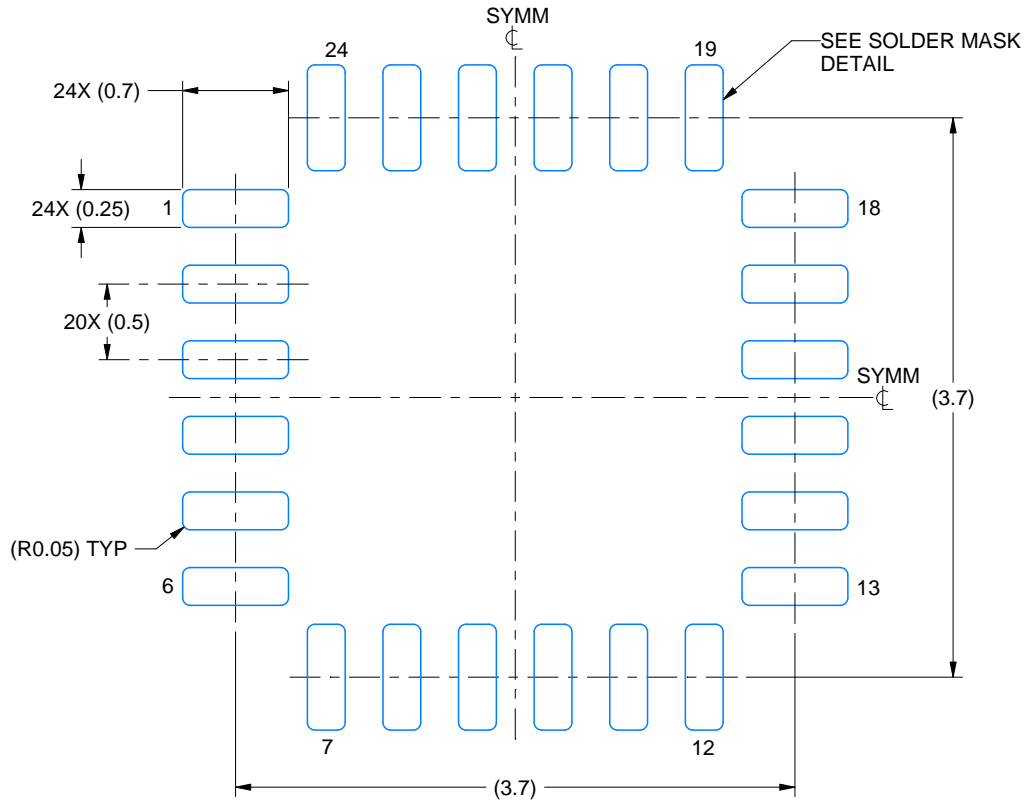

LAND PATTERN EXAMPLE  
EXPOSED METAL SHOWN  
SCALE: 20X

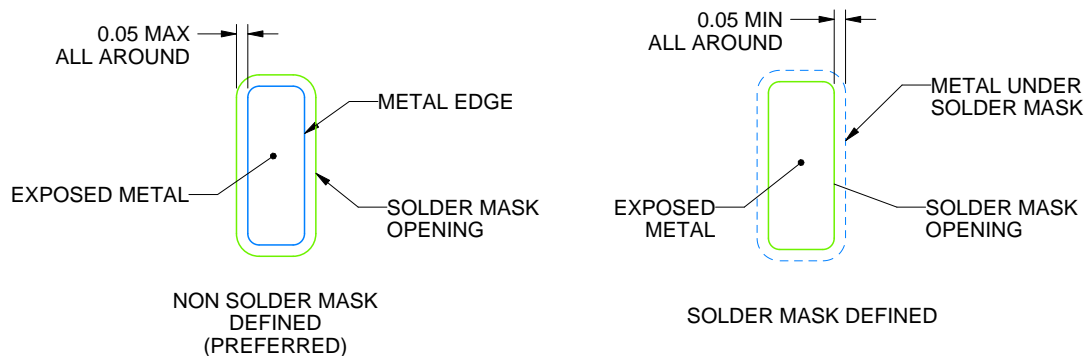

SOLDER MASK DETAILS

4225850/A 04/2020

NOTES: (continued)

- This package is designed to be soldered to a thermal pad on the board. For more information, see Texas Instruments literature number SLUA271 ([www.ti.com/lit/sluea271](http://www.ti.com/lit/sluea271)).
- Vias are optional depending on application, refer to device data sheet. If any vias are implemented, refer to their locations shown on this view. It is recommended that vias under paste be filled, plugged or tented.

# EXAMPLE STENCIL DESIGN

RRU0024A

UQFN - 0.7 mm max height

PLASTIC QUAD FLATPACK - NO LEAD

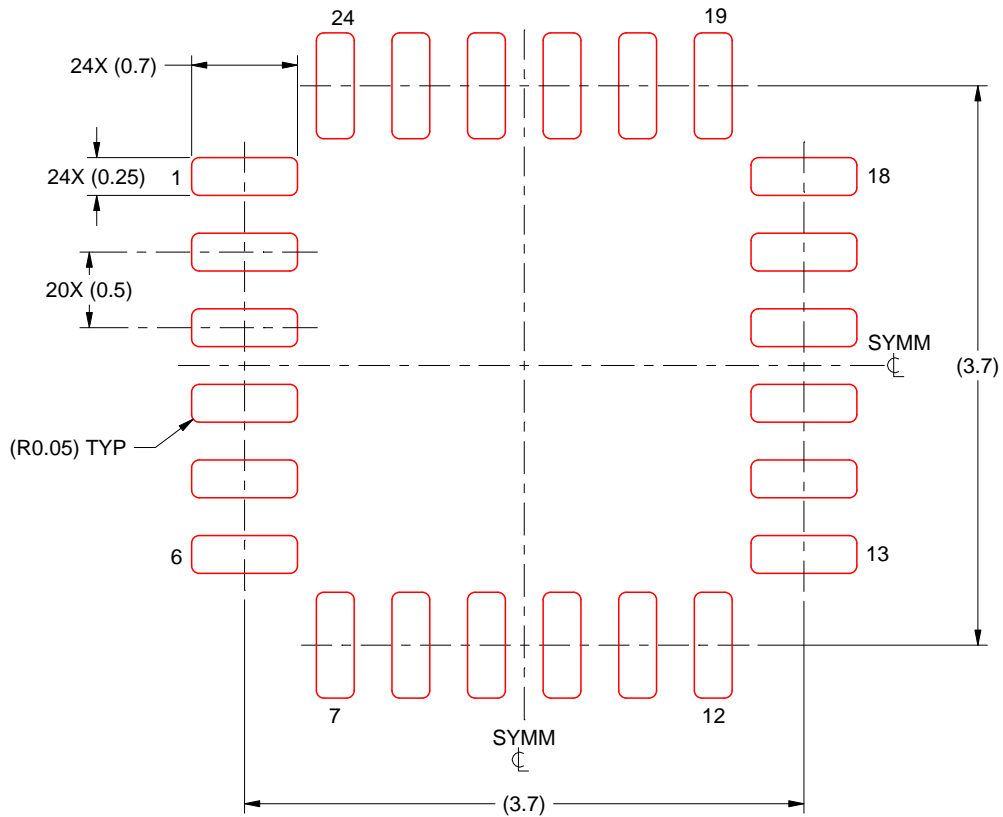

SOLDER PASTE EXAMPLE  
BASED ON 0.125 MM THICK STENCIL  
SCALE: 20X

4225850/A 04/2020

NOTES: (continued)

6. Laser cutting apertures with trapezoidal walls and rounded corners may offer better paste release. IPC-7525 may have alternate design recommendations.

## 重要声明和免责声明

TI“按原样”提供技术和可靠性数据（包括数据表）、设计资源（包括参考设计）、应用或其他设计建议、网络工具、安全信息和其他资源，不保证没有瑕疵且不做任何明示或暗示的担保，包括但不限于对适销性、某特定用途方面的适用性或不侵犯任何第三方知识产权的暗示担保。

这些资源可供使用 TI 产品进行设计的熟练开发人员使用。您将自行承担以下全部责任：(1) 针对您的应用选择合适的 TI 产品，(2) 设计、验证并测试您的应用，(3) 确保您的应用满足相应标准以及任何其他功能安全、信息安全、监管或其他要求。

这些资源如有变更，恕不另行通知。TI 授权您仅可将这些资源用于研发本资源所述的 TI 产品的应用。严禁对这些资源进行其他复制或展示。您无权使用任何其他 TI 知识产权或任何第三方知识产权。您应全额赔偿因在这些资源的使用中对 TI 及其代表造成的任何索赔、损害、成本、损失和债务，TI 对此概不负责。

TI 提供的产品受 [TI 的销售条款](#) 或 [ti.com](#) 上其他适用条款/TI 产品随附的其他适用条款的约束。TI 提供这些资源并不会扩展或以其他方式更改 TI 针对 TI 产品发布的适用的担保或担保免责声明。

TI 反对并拒绝您可能提出的任何其他或不同的条款。

邮寄地址：Texas Instruments, Post Office Box 655303, Dallas, Texas 75265

Copyright © 2024，德州仪器 (TI) 公司