

# ADS92x4R 双通道低延迟同步采样 SAR ADC

## 1 特性

- 高分辨率、高吞吐量：
  - ADS9224R: 16 位、3MSPS、低延迟: 333ns
  - ADS9234R: 14 位、3.5MSPS、低延迟: 285ns
- 两个单极、完全差分同步采样通道
- 出色的直流和交流性能：
  - ADS9224R:
    - 16 位 NMC DNL,  $\pm 2$ LSB 最大 INL
    - 94dB SNR、-109dB THD
    - 1MHz 时为 88dB SINAD
  - ADS9234R:
    - 14 位 NMC DNL,  $\pm 1$ LSB 最大 INL
    - 85.6dB SNR、-106dB THD
    - 1MHz 时为 84dB SINAD
- 特性集成：
  - 内部基准和基准缓冲器
  - 用于设置共模的内部 REFby2 缓冲器
  - 数据平均
- 适用于 MCU 和 FPGA 的增强型 SPI 接口：
  - 宽读取周期, 可借助 MCU 读取数据
  - 用于通过数字隔离器进行数据传输的时钟重计时器
  - 适用于 FPGA 的 DDR 模式
  - 并行字节模式, 方便对接
- 扩展温度范围:  $-40^{\circ}\text{C}$  至  $+125^{\circ}\text{C}$

## 2 应用

- 光学编码器: 增量和绝对编码器
- 声纳接收器
- 光纤网络: EDFA 增益控制环路
- 电源质量测量
- 数字电源
- I/Q 解调器
- 医疗成像: CT 扫描仪、MRI 扫描仪
- 阻抗分析仪

## 3 说明

ADS92x4R 是一款引脚兼容型高速双通道同步采样模数转换器 (ADC), 具有集成基准电压和基准电压缓冲器。该器件可由 5V 单电源供电运行, 支持单极和全差分模拟输入信号, 具有出色的直流和交流规格。该器件具有高达 1.5MHz 的模拟输入频率, 交流性能出色, 因此适合高带宽数据采集 (DAQ) 系统。

该器件支持 SPI 兼容串行 (增强型 SPI) 和字节宽并行接口, 因此易于与多种微控制器、数字信号处理器 (DSP) 和现场可编程门阵列 (FPGA) 搭配使用。此器件还支持数据平均功能, 该功能可提升高噪声环境中的交流性能。

该器件采用节省空间的 5mm x 5mm VQFN 封装。ADS92x4R 的额定扩展温度范围为  $-40^{\circ}\text{C}$  至  $+125^{\circ}\text{C}$ 。

### 器件信息<sup>(1)</sup>

器件型号	封装	封装尺寸 (标称值)
ADS92x4R	VQFN (32)	5.00mm x 5.00mm

(1) 如需了解所有可用封装, 请参阅产品说明书末尾的可订购产品附录。

### 典型应用图

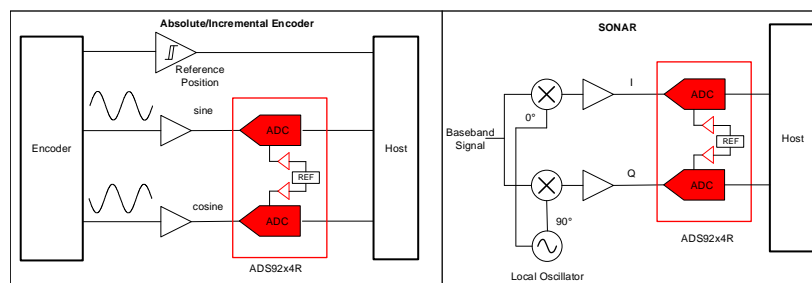

## 目录

1	特性 .....	1	7.4	Device Functional Modes .....	26
2	应用 .....	1	7.5	READY/STROBE Output .....	30
3	说明 .....	1	7.6	Programming .....	30
4	修订历史记录 .....	2	7.7	Register Maps .....	43
5	<b>Pin Configuration and Functions</b> .....	3	<b>8</b>	<b>Application and Implementation</b> .....	49
6	<b>Specifications</b> .....	5	8.1	Application Information .....	49
6.1	Absolute Maximum Ratings .....	5	8.2	Typical Application .....	51
6.2	ESD Ratings .....	5	<b>9</b>	<b>Power Supply Recommendations</b> .....	53
6.3	Recommended Operating Conditions .....	5	<b>10</b>	<b>Layout</b> .....	54
6.4	Thermal Information .....	5	10.1	Layout Guidelines .....	54
6.5	Electrical Characteristics: ADS92x4R .....	6	10.2	Layout Example .....	55
6.6	Electrical Characteristics: ADS9224R .....	7	<b>11</b>	<b>器件和文档支持</b> .....	56
6.7	Electrical Characteristics: ADS9234R .....	8	11.1	器件支持 .....	56
6.8	Timing Requirements .....	9	11.2	相关文档 .....	56
6.9	Switching Characteristics .....	10	11.3	相关链接 .....	56
6.10	Typical Characteristics: ADS9224R .....	15	11.4	接收文档更新通知 .....	56
6.11	Typical Characteristics: ADS9234R .....	18	11.5	社区资源 .....	56
<b>7</b>	<b>Detailed Description</b> .....	21	11.6	商标 .....	56
7.1	Overview .....	21	11.7	静电放电警告 .....	56
7.2	Functional Block Diagram .....	21	11.8	Glossary .....	56
7.3	Feature Description .....	22	<b>12</b>	<b>机械、封装和可订购信息</b> .....	57

## 4 修订历史记录

注：之前版本的页码可能与当前版本有所不同。

Changes from Revision B (May 2019) to Revision C	Page
• 已更改 将文档状态从“预告信息”更改为“生产数据” .....	1

## 5 Pin Configuration and Functions

**RHB Package**  
5-mm × 5-mm, 32-Pin VQFN  
Top View

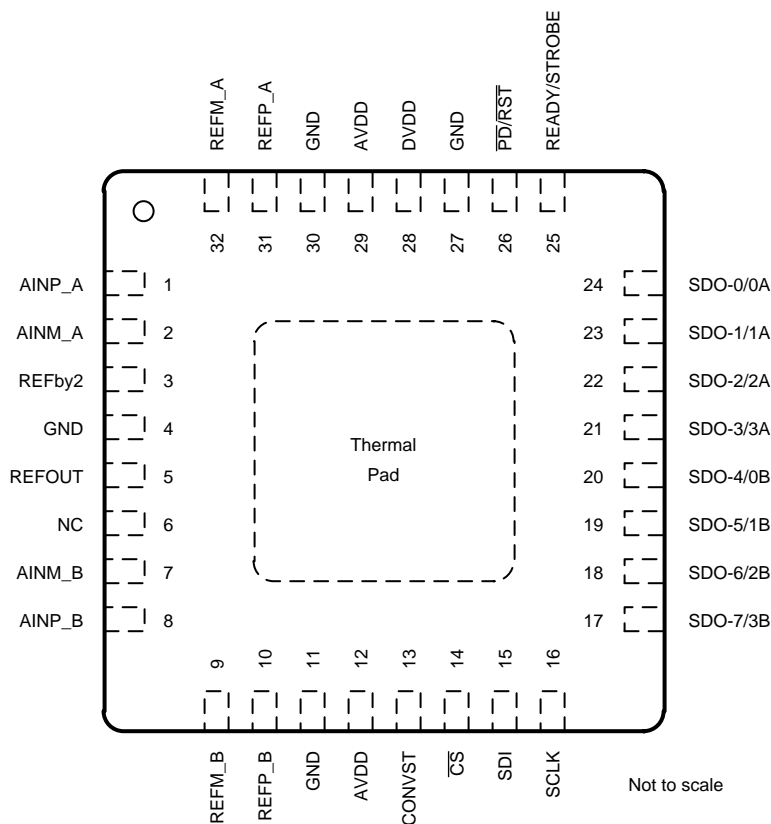

### Pin Functions

PIN		FUNCTION	DESCRIPTION
NAME	NO.		
AINM_A	2	Analog input	Negative analog input for channel A.
AINM_B	7	Analog input	Negative analog input for channel B.
AINP_A	1	Analog input	Positive analog input for channel A.
AINP_B	8	Analog input	Positive analog input for channel B.
AVDD	12, 29	Power supply	Analog power-supply pin. Connect a 1- $\mu$ F decoupling capacitor between pin 12 and pin 11. Connect a 1- $\mu$ F decoupling capacitor between pin 29 and pin 30.
CONVST	13	Digital input	Conversion start input pin. A CONVST rising edge starts the conversion for ADC_A and ADC_B.
$\overline{CS}$	14	Digital input	Chip-select input pin; active low. The host and device can communicate when $\overline{CS}$ is low. The SDO-x pins go to Hi-Z when $\overline{CS}$ is high.
DVDD	28	Power supply	Interface power-supply pin. Connect a 1- $\mu$ F decoupling capacitor between pin 27 and pin 28.
GND	4, 11, 27, 30	Power supply	Ground
NC	6	—	No external connection
$\overline{PD/RST}$	26	Digital input	Asynchronous reset or power-down input pin. See the <a href="#">Reset or Power-Down</a> section.
READY/STROBE	25	Digital output	Indicates data ready or strobe output for data capture.

**Pin Functions (continued)**

PIN		FUNCTION	DESCRIPTION
NAME	NO.		
REFby2	3	Analog output	REFby2 buffer output. Connect a 1- $\mu$ F decoupling capacitor between pin 3 and pin 4.
REFOUT	5	Analog output	Internal reference output. Connect a 1- $\mu$ F decoupling capacitor between pin 5 and pin 4.
REFM_A	32	Analog output	Negative output of reference buffer A. Negative reference input for ADC_A. Externally connect to the device GND.
REFM_B	9	Analog output	Negative output of reference buffer B. Negative reference input for ADC_B. Externally connect to the device GND.
REFP_A	31	Analog output	Positive output of reference buffer A. Positive reference input for ADC_A. Connect a 10- $\mu$ F decoupling capacitor between pin 31 and pin 32.
REFP_B	10	Analog output	Positive output of reference buffer B. Positive reference input for ADC_B. Connect a 10- $\mu$ F decoupling capacitor between pin 9 and pin 10.
SCLK	16	Digital input	Clock input pin for the serial interface.
SDI	15	Digital input	Serial data input pin. This pin is used to program the device registers.
SDO-0/0A	24	Digital output	SPI mode: data output 0 for channel A. Parallel byte mode: least significant bit (LSB) from the data byte.
SDO-1/1A	23	Digital output	SPI mode: data output 1 for channel A. Parallel byte mode: LSB+1 from the data byte.
SDO-2/2A	22	Digital output	SPI mode: data output 2 for channel A. Parallel byte mode: LSB+2 from the data byte.
SDO-3/3A	21	Digital output	SPI mode: data output 3 for channel A. Parallel byte mode: LSB+3 from the data byte.
SDO-4/0B	20	Digital output	SPI mode: data output 0 for channel B. Parallel byte mode: LSB+4 from the data byte.
SDO-5/1B	19	Digital output	SPI mode: data output 1 for channel B. Parallel byte mode: LSB+5 from the data byte.
SDO-6/2B	18	Digital output	SPI mode: data output 2 for channel B. Parallel byte mode: LSB+6 from the data byte.
SDO-7/3B	17	Digital output	SPI mode: data output 3 for channel B. Parallel byte mode: most significant bit (MSB) from the data byte.
Thermal pad		Power supply	Exposed thermal pad. TI recommends connecting this pin to the printed circuit board (PCB) ground.

## 6 Specifications

### 6.1 Absolute Maximum Ratings

over operating free-air temperature range (unless otherwise noted)<sup>(1)</sup>

	MIN	MAX	UNIT
AVDD to GND	-0.3	6	V
DVDD to GND	-0.3	6	V
Digital input pins	GND - 0.3	DVDD + 0.3	V
Digital output pins	GND - 0.3	DVDD + 0.3	V
AINP_A, AINP_B to GND, AINM_A, AINM_B to GND	-0.3	AVDD + 0.3	V
REFM_A, REFM_B	GND - 0.1	GND + 0.1	V
REFP_A, REFP_B, REFOUT, REFby2 to GND	GND - 0.3	AVDD + 0.3	V
Input or output current to any pin except power-supply pin	-10	10	mA
Junction temperature, T <sub>J</sub>		150	°C
Storage temperature, T <sub>stg</sub>	-65	150	°C

- (1) Stresses beyond those listed under *Absolute Maximum Rating* may cause permanent damage to the device. These are stress ratings only, which do not imply functional operation of the device at these or any other conditions beyond those indicated under *Recommended Operating Condition*. Exposure to absolute-maximum-rated conditions for extended periods may affect device reliability.

### 6.2 ESD Ratings

		VALUE	UNIT
V <sub>(ESD)</sub>	Electrostatic discharge	Human body model (HBM), per ANSI/ESDA/JEDEC JS-001, all pins <sup>(1)</sup>	V
		Charged device model (CDM), per JEDEC specification JESD22-C101, all pins <sup>(2)</sup>	

- (1) JEDEC document JEP155 states that 500-V HBM allows safe manufacturing with a standard ESD control process.

- (2) JEDEC document JEP157 states that 250-V CDM allows safe manufacturing with a standard ESD control process.

### 6.3 Recommended Operating Conditions

over operating free-air temperature range (unless otherwise noted)

		MIN	NOM	MAX	UNIT
AVDD	Analog supply voltage	4.5	5	5.5	V
DVDD	Digital supply voltage operating range	1.65	3.3	5.5	V
	Digital supply voltage for SCLK > 20 MHz	2.35	3.3	5.5	V
T <sub>A</sub>	Ambient temperature	-40		125	°C

### 6.4 Thermal Information

THERMAL METRIC <sup>(1)</sup>		ADS92x4R	UNIT
		RHB (VQFN)	
		32 PINS	
R <sub>θJA</sub>	Junction-to-ambient thermal resistance	29	°C/W
R <sub>θJC(top)</sub>	Junction-to-case (top) thermal resistance	17.1	°C/W
R <sub>θJB</sub>	Junction-to-board thermal resistance	9.4	°C/W
Ψ <sub>JT</sub>	Junction-to-top characterization parameter	0.2	°C/W
Ψ <sub>JB</sub>	Junction-to-board characterization parameter	9.4	°C/W
R <sub>θJC(bot)</sub>	Junction-to-case (bottom) thermal resistance	0.8	°C/W

- (1) For more information about traditional and new thermal metrics, see the [Semiconductor and IC Package Thermal Metrics](#) application report.

## 6.5 Electrical Characteristics: ADS92x4R

at AVDD = 4.5 V to 5.5V, DVDD = 2.35 V to 5.5 V,  $V_{CM} = V_{REFP\_x/2}$ , Internal reference and maximum throughput (unless otherwise noted); minimum and maximum values at  $T_A = -40^{\circ}\text{C}$  to  $+125^{\circ}\text{C}$ ; typical values at  $T_A = 25^{\circ}\text{C}$ , AVDD = 5V, DVDD = 3.3 V

PARAMETER	TEST CONDITIONS	MIN	TYP	MAX	UNIT	
<b>ANALOG INPUT</b>						
FSR <sup>(1)</sup>	Full-scale input voltage (AINP_x - AINM_x)	-4.096		4.096	V	
V <sub>IN</sub>	Absolute input voltage (AINP_x or AINM_x to GND)	0		4.096	V	
V <sub>CM</sub>	Common-mode input range	1.848		2.248	V	
I <sub>IN</sub>	Analog input leakage current		±1		μA	
C <sub>i</sub>	Input capacitance	Sample mode	16		pF	
		Hold mode	1			
BW	Analog input bandwidth	-3-dB input signal	52		MHz	
		-0.1-dB input signal	4.2		MHz	
<b>VOLTAGE REFERENCE OUTPUT</b>						
V <sub>REFOUT</sub> <sup>(2)</sup>	REFOUT voltage	2.496	2.5	2.504	V	
ΔV <sub>REF</sub> /ΔT	V <sub>REFOUT</sub> drift		5.5	15	ppm/°C	
ΔV <sub>REFOUT</sub> /ΔAVDD	V <sub>REFOUT</sub> line regulation	AVDD variation 4.5 V to 5.5 V	200		μV/V	
I <sub>REFOUT</sub>	REFOUT output current capability	ΔV <sub>REF</sub>   < 2 mV	1.5		μA	
C <sub>REFOUT</sub>	REFOUT capacitor	For specified performance	1		μF	
<b>INTERNAL REFERENCE BUFFER</b>						
G <sub>REFBUF</sub>	Reference buffer Gain		1.6388		V/V	
E <sub>O-REFBUF</sub>	Reference buffer output offset	-1	±0.2	1	mV	
ΔE <sub>O-REFBUF</sub> /ΔT	Reference buffer output offset temperature drift		10		μV/°C	
(V <sub>REFP_A</sub> - V <sub>REFP_B</sub> )	Reference buffer output mismatch	-500	±50	500	μV	
C <sub>REFP_x</sub>	Reference buffer output capacitor	For specified performance, between each pair of REFP_x and REFM_x	7	10	27	μF
<b>REFby2 OUTPUT</b>						
V <sub>REFby2</sub>	REFby2 output voltage	EN_REFBY2_OFFSET = 0	2.043	2.048	2.053	V
		EN_REFBY2_OFFSET = 1	2.133	2.148	2.163	V
I <sub>REFby2</sub>	REFby2 output current capability		±3		mA	
	REFby2 output capacitor		1		μF	
	REFby2 output noise	With specified output capacitor		10	μV <sub>RMS</sub>	
<b>Digital Outputs</b>						
V <sub>OH</sub>	High level output voltage	I <sub>OH</sub> = 500-μA source	0.8 × DVDD		DVDD	V
V <sub>OL</sub>	Low level output voltage	I <sub>OL</sub> = 500-μA sink	0		0.2 × DVDD	V
<b>Digital Inputs</b>						
V <sub>IH</sub>	High level input voltage	DVDD > 2.3 V	0.7 × DVDD		DVDD +0.3	V
V <sub>IL</sub>	Low level input voltage		-0.3		0.3 × DVDD	V
V <sub>IH</sub>	High level input voltage	DVDD ≤ 2.3 V	0.8 × DVDD		DVDD +0.3	V
V <sub>IL</sub>	Low level input voltage		-0.3		0.2 × DVDD	V

(1) Ideal input span; does not include gain or offset error.

(2) Does not include the variation in voltage resulting from solder shift effects.

## Electrical Characteristics: ADS92x4R (continued)

at AVDD = 4.5 V to 5.5V, DVDD = 2.35 V to 5.5 V,  $V_{CM} = V_{REFP\_x/2}$ , Internal reference and maximum throughput (unless otherwise noted); minimum and maximum values at  $T_A = -40^{\circ}\text{C}$  to  $+125^{\circ}\text{C}$ ; typical values at  $T_A = 25^{\circ}\text{C}$ , AVDD = 5V, DVDD = 3.3 V

PARAMETER		TEST CONDITIONS	MIN	TYP	MAX	UNIT
<b>Power Supply</b>						
AVDD	Analog supply voltage		4.5	5	5.5	V
DVDD	Digital supply voltage		1.65	3.3	5.5	V
I <sub>AVDD</sub>	Analog supply current	f <sub>SAMPLE</sub> = 3 MSPS		24.3	30.4	mA
		AVDD = 5 V, no conversion		7.8		mA
		Power down (PD/RST Low)		1		μA
I <sub>DVDD</sub>	Digital supply current	f <sub>SAMPLE</sub> = 3 MSPS, C <sub>SDO-x/y</sub> = 10 pF		2.8		mA
PSRR <sup>(3)</sup>	Power-supply rejection ratio	100-mV <sub>PP</sub> Ripple on AVDD of frequency < 100kHz		70		dB

(3) All specifications expressed in decibels (dB) refer to the full-scale input (FSR) and are tested with an input signal 0.5 dB below full-scale, unless otherwise specified.

## 6.6 Electrical Characteristics: ADS9224R

at AVDD = 4.5 V to 5.5V, DVDD = 2.35 V to 5.5 V,  $V_{CM} = V_{REFP\_x/2}$ , Internal reference and maximum throughput (unless otherwise noted); minimum and maximum values at  $T_A = -40^{\circ}\text{C}$  to  $+125^{\circ}\text{C}$ ; typical values at  $T_A = 25^{\circ}\text{C}$ , AVDD = 5V, DVDD = 3.3 V

PARAMETER		TEST CONDITIONS	MIN	TYP	MAX	UNIT
<b>DC ACCURACY</b>						
	Resolution, no missing codes		16			Bits
DNL	Differential nonlinearity		-0.5	±0.2	0.5	LSB
INL	Integral nonlinearity		-2	±1	2	LSB
E <sub>O</sub>	Offset error		-9	±1	9	LSB
G <sub>E</sub>	Cummulative gain error for ADC <sub>x</sub> and REFBUF <sub>x</sub>		-0.02	±0.01	0.02	%FSR
ΔG <sub>E</sub> /ΔT	Gain drift			5		ppm/°C
	Transition noise	Mid-code, PFS-1000, NFS+1000		0.4		LSB
<b>AC ACCURACY</b>						
SNR <sup>(1)</sup>	Signal-to-noise ratio	f <sub>IN</sub> = 2 kHz	91.3	94.5		dB
		f <sub>IN</sub> = 100 kHz, FSR = -3 dBFS		93		
		f <sub>IN</sub> = 1 MHz, FSR = -3 dBFS, f <sub>SAMPLE</sub> = 2.9 MSPS		89.5		
SINAD <sup>(1)(2)</sup>	Signal-to-noise plus distortion	f <sub>IN</sub> = 2 kHz		94.3		dB
		f <sub>IN</sub> = 100 kHz, FSR = -3 dBFS		92.7		
		f <sub>IN</sub> = 1 MHz, FSR = -3 dBFS		87.9		
THD <sup>(1)(2)</sup>	Total harmonic distortion	f <sub>IN</sub> = 2 kHz		-109		dB
		f <sub>IN</sub> = 100 kHz, FSR = -3 dBFS		-106		
		f <sub>IN</sub> = 1 MHz, FSR = -3 dBFS		-93		
SFDR <sup>(1)</sup>	Spurious-free dynamic range	f <sub>IN</sub> = 2 kHz		112		dB
		f <sub>IN</sub> = 100 kHz, FSR = -3 dBFS		112		
		f <sub>IN</sub> = 1 MHz, FSR = -3 dBFS		100		
CMRR <sup>(1)</sup>	Common-mode rejection ratio	f <sub>IN</sub> = dc to 1-MHz, V <sub>IN</sub> = 100-mV <sub>PP</sub>		80		dB

(1) All specifications expressed in decibels (dB) refer to the full-scale input (FSR) and are tested with an input signal 0.5 dB below full-scale, unless otherwise specified.

(2) Calculated on the first nine harmonics of the input frequency.

## Electrical Characteristics: ADS9224R (continued)

at AVDD = 4.5 V to 5.5V, DVDD = 2.35 V to 5.5 V,  $V_{CM} = V_{REFP\_x/2}$ , Internal reference and maximum throughput (unless otherwise noted); minimum and maximum values at  $T_A = -40^{\circ}\text{C}$  to  $+125^{\circ}\text{C}$ ; typical values at  $T_A = 25^{\circ}\text{C}$ , AVDD = 5V, DVDD = 3.3 V

PARAMETER	TEST CONDITIONS	MIN	TYP	MAX	UNIT
ISOXT <sup>(1)</sup>	Channel-to-channel isolation	$f_{IN\_ADCA} = 15\text{ kHz}$ at 10% FSR, $f_{IN\_ADCB} = 25\text{ kHz}$ at 100% FSR	-120		dB

## 6.7 Electrical Characteristics: ADS9234R

at AVDD = 4.5 V to 5.5V, DVDD = 2.35 V to 5.5 V,  $V_{CM} = V_{REFP\_x/2}$ , Internal reference and maximum throughput (unless otherwise noted); minimum and maximum values at  $T_A = -40^{\circ}\text{C}$  to  $+125^{\circ}\text{C}$ ; typical values at  $T_A = 25^{\circ}\text{C}$ , AVDD = 5V, DVDD = 3.3 V

PARAMETER	TEST CONDITIONS	MIN	TYP	MAX	UNIT	
<b>DC ACCURACY</b>						
	Resolution, no missing codes		14		Bits	
DNL	Differential nonlinearity		-0.5	$\pm 0.15$	0.5	LSB
INL	Integral nonlinearity		-1	$\pm 0.3$	1	LSB
E <sub>O</sub>	Offset error		-3.5	$\pm 0.8$	3.5	LSB
G <sub>E</sub>	Cummulative gain error for ADC_x and REFBUF_x		-0.025	$\pm 0.01$	0.025	%FSR
$\Delta G_E/\Delta T$	Gain drift			5		ppm/ $^{\circ}\text{C}$
	Transition noise	Mid-code, PFS-1000, NFS+1000		0.3		LSB
<b>AC ACCURACY</b>						
SNR <sup>(1)</sup>	Signal-to-noise ratio	$f_{IN} = 2\text{ kHz}$	84.1	85.6	dB	
		$f_{IN} = 100\text{ kHz}$ , FSR = -3 dBFS		85.5		
		$f_{IN} = 1\text{ MHz}$ , FSR = -3 dBFS		85		
SINAD <sup>(1)(2)</sup>	Signal-to-noise plus distortion	$f_{IN} = 2\text{ kHz}$		85.5	dB	
		$f_{IN} = 100\text{ kHz}$ , FSR = -3 dBFS		85.4		
		$f_{IN} = 1\text{ MHz}$ , FSR = -3 dBFS		84.4		
THD <sup>(1)(2)</sup>	Total harmonic distortion	$f_{IN} = 2\text{ kHz}$		-106	dB	
		$f_{IN} = 100\text{ kHz}$ , FSR = -3 dBFS		-106		
		$f_{IN} = 1\text{ MHz}$ , FSR = -3 dBFS		-94		
SFDR <sup>(1)</sup>	Spurious-free dynamic range	$f_{IN} = 2\text{ kHz}$		109	dB	
		$f_{IN} = 100\text{ kHz}$ , FSR = -3 dBFS		107		
		$f_{IN} = 1\text{ MHz}$ , FSR = -3 dBFS		101		
CMRR <sup>(1)</sup>	Common-mode rejection ratio	$f_{IN} = \text{dc to } 1\text{-MHz}$ , $V_{IN} = 100\text{-mV}_{PP}$		75	dB	
ISOXT <sup>(1)</sup>	Channel-to-channel isolation	$f_{IN\_ADCA} = 15\text{ kHz}$ at 10% FSR, $f_{IN\_ADCB} = 25\text{ kHz}$ at 100% FSR		-115	dB	

(1) All specifications expressed in decibels (dB) refer to the full-scale input (FSR) and are tested with an input signal 0.5 dB below full-scale, unless otherwise specified.

(2) Calculated on the first nine harmonics of the input frequency.



## 6.8 Timing Requirements

at AVDD = 4.5 V to 5.5V, DVDD = 2.35 V to 5.5 V,  $V_{CM} = V_{REFP\_x/2}$ , Internal reference and maximum throughput (unless otherwise noted); minimum and maximum values at  $T_A = -40^{\circ}\text{C}$  to  $+125^{\circ}\text{C}$ ; typical values at  $T_A = 25^{\circ}\text{C}$ , AVDD = 5V, DVDD = 3.3 V

		MIN	NOM	MAX	UNIT
<b>CONVERSION CONTROL AND DATA TRANSFER (See 图 1 and 图 2)</b>					
$t_{D\_CONVST\_CS}$	Delay time: CONVST high to $\overline{CS}$ Falling for zero cycle latency (zone 1 transfer)	$t_{DRDY}^{(1)}$			ns
$t_{CYCLE}$	Time between two adjacent CONVST rising edges for zero cycle latency (zone 1 transfer)	$t_{DRDY} + t_{READ}^{(2)}$			ns
	Time between two adjacent CONVST rising edges for zone 2 transfer, ADS9224R	333			ns
	Time between two adjacent CONVST rising edges for zone 2 transfer, ADS9234R	285			
$f_{SAMPLE}$	Sampling rate, ADS9224R			3	MSPS
	Sampling rate, ADS9234R			3.5	
$t_{ACQ}$	Acquisition time	140			ns
$t_{D\_CONVST\_CS}$	Delay time: CONVST high to $\overline{CS}$ falling for zone 2 transfer	15		180	ns
$t_{WL\_CONVST}$	Pulse duration : CONVST low	15			ns
$t_{WH\_CONVST}$	Pulse duration : CONVST high	15			ns
<b>SPI-COMPATIBLE AND PARALLEL BYTE PROTOCOL (See 图 3)</b>					
$t_{CLK}$	Serial clock time period	$1/f_{CLK}$			
$t_{PH\_CLK}$	SCLK high time	$0.45 \times t_{CLK}$		$0.55 \times t_{CLK}$	ns
$t_{PL\_CLK}$	SCLK low time	$0.45 \times t_{CLK}$		$0.55 \times t_{CLK}$	ns
$t_{SU\_CSCK}$	Setup time: $\overline{CS}$ falling to first SCLK capture edge	12			ns
$t_{SU\_CKDI}$	Setup Time: SDI data valid to SCLK capture edge	2.5			ns
$t_{HT\_CKDI}$	Hold Time: SCLK capture edge to previous data valid on SDI	1.5			ns
$t_{HT\_CKCS}$	Delay Time: last SCLK capture edge to $\overline{CS}$ rising	14			ns
$f_{CLK}$	Serial clock frequency for SPI protocols with single data rate			60	MHz
	Serial clock frequency for SPI protocols with double data rate			22	MHz
	Serial clock frequency for parallel byte protocol			45	MHz
<b>CLOCK RE-TIMER PROTOCOL WITH STROBE = SCLK (EXTERNAL CLOCK)<sup>(3)</sup>(See 图 4)</b>					
$f_{CLK}$	Serial clock frequency with single data rate			60	MHz
	Serial clock frequency with double data rate			22	MHz
<b>ASYNCHRONOUS RESET AND POWER-DOWN TIMING (See 图 6)</b>					
$t_{WL\_RST}$	Pulse duration (low) for reset	50		500	ns
$t_{WL\_PD-min}$	Minimum pulse duration (low) for power-down	1000			ns

(1) See Switching Characteristics

(2) See [Protocols for Reading From the Device](#) for  $t_{READ}$

(3) Other parameters are the same as the SPI-compatible and Parallel Byte Protocols.

## 6.9 Switching Characteristics

at AVDD = 4.5 V to 5.5V, DVDD = 2.35 V to 5.5 V,  $V_{CM} = V_{REF/2}$ , Internal reference and maximum throughput (unless otherwise noted); minimum and maximum values at  $T_A = -40^\circ\text{C}$  to  $+125^\circ\text{C}$ ; typical values at  $T_A = 25^\circ\text{C}$ , AVDD = 5V, DVDD = 3.3 V

PARAMETER	TEST CONDITIONS	MIN	TYP	MAX	UNIT
<b>CONVERSION CONTROL AND DATA TRANSFER (See <a href="#">Figure 1</a> and <a href="#">Figure 2</a>)</b>					
$t_{DRDY}$	Data ready time for present sample: CONVST high to READY high	Zero cycle latency (zone 1 transfer) for ADS9224R		315	ns
	Data ready time for present sample: CONVST high to READY high	Zero cycle latency (zone 1 transfer) for ADS9234R		280	ns
<b>SPI-COMPATIBLE AND PARALLEL BYTE PROTOCOL (See <a href="#">Figure 3</a>)</b>					
$t_{DEN\_CSDO}$	Delay time: $\overline{CS}$ falling to data valid on SDO-x			12	ns
$t_{DZ\_CSDO}$	Delay time: $\overline{CS}$ rising edge to SDO-x tristate			12	ns
$t_{D\_CKDO}$	Delay time: SCLK launch edge to next data valid on SDO-x	SPI-compatible protocols with single data rate		15.8	ns
$t_{D\_CKDO}$	Delay time: SCLK launch edge to next data valid on SDO-x	SPI-compatible protocols with double data rate		21	ns
$t_{D\_CKDO}$	Delay time: SCLK launch edge to next data valid on SDO-x	Parallel byte protocol		21	ns
$t_A$	Aperture delay		8		ns
	$t_A$ mismatch		40		ps
$t_{JITTER}$	Aperture jitter		2		ps
<b>CLOCK RE-TIMER PROTOCOL WITH STROBE = SCLK (EXTERNAL CLOCK)<sup>(1)</sup>(See <a href="#">Figure 4</a>)</b>					
$t_{OFF\_STROBE\_DO}$	Time offset: STROBE edge to next data valid on SDO-x		-2.5	2.5	ns
$t_{D\_CS\_READY}$	Delay time: $\overline{CS}$ rising to READY displaying internal device state			13.5	ns
$t_{D\_CKSTROBE\_r}$	Delay time: SCLK rising edge to STROBE rising			21.5	ns
$t_{D\_CKSTROBE\_f}$	Delay time: SCLK falling edge to STROBE falling			21.5	ns
$t_{PH\_STROBE}$	Strobe output high time		$0.45 \times t_{STR}$	$0.55 \times t_{STR}$	ns
$t_{PL\_STROBE}$	Strobe output low time		$0.45 \times t_{STR}$	$0.55 \times t_{STR}$	ns
<b>CLOCK RE-TIMER PROTOCOL WITH STROBE = INTERNAL CLOCK <sup>(1)</sup>(See <a href="#">Figure 5</a>)</b>					
$t_{D\_CS\_STROBE}$	Delay time : $\overline{CS}$ falling to 1 <sup>st</sup> STROBE rising		15	50	ns
$t_{OFF\_STROBE\_DO}$	Time offset : STROBE edge to next data valid on SDO-x		-2.5	2.5	ns
$t_{D\_CS\_READY}$	Delay time: $\overline{CS}$ rising to READY displaying internal device state			13.5	ns
$t_{INTCLK}$	INTCLK period			15	ns
$t_{STR}$	STROBE period	INTCLK		16	ns
		INTCLK / 2		30	ns
		INTCLK / 4		60	ns
$t_{WH\_STR}$	STROBE high period		$0.45 \times t_{STR}$	$0.55 \times t_{STR}$	ns
$t_{WL\_STR}$	STROBE low period		$0.45 \times t_{STR}$	$0.55 \times t_{STR}$	ns

(1) Other parameters are the same as the SPI-compatible and Parallel Byte Protocols.

### Switching Characteristics (continued)

at AVDD = 4.5 V to 5.5V, DVDD = 2.35 V to 5.5 V,  $V_{CM} = V_{REF/2}$ , Internal reference and maximum throughput (unless otherwise noted); minimum and maximum values at  $T_A = -40^{\circ}\text{C}$  to  $+125^{\circ}\text{C}$ ; typical values at  $T_A = 25^{\circ}\text{C}$ , AVDD = 5V, DVDD = 3.3 V

PARAMETER	TEST CONDITIONS	MIN	TYP	MAX	UNIT
<b>ASYNCHRONOUS RESET AND POWER-DOWN TIMING (See 图 6)</b>					
$t_{RST-WKUP}$	Wake up time from reset			1	$\mu\text{s}$
$t_{PD-WKUP}^{(2)}$	Wake up time from power-down		18	150	ms
$t_{WKUP-REFOUT}$	REFOUT wake-up time		15.6	140	ms
$t_{REFP\_X-SETTLE}$	Reference buffer output settling time	$C_{REFP\_X} = 10\mu\text{F}$	18	150	ms

(2) With  $C_{REFP\_X} = 10\mu\text{F}$

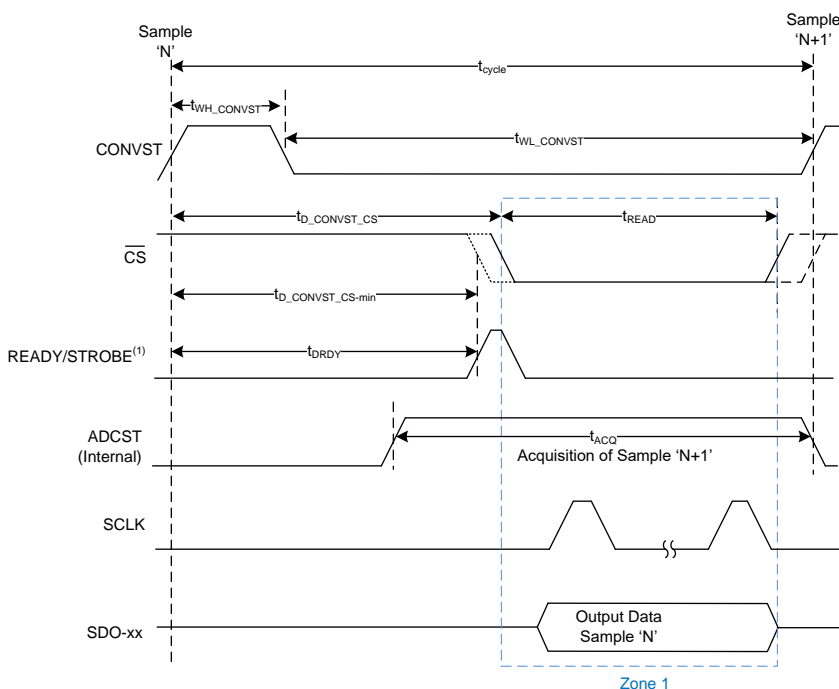

(1) The READY output is required for data transfer with zero cycle latency. The STROBE output is required only for clock re-timer (CRT) protocols.

**图 1. Conversion Control and Data Transfer With Zero Cycle Latency (Zone 1 Transfer)**

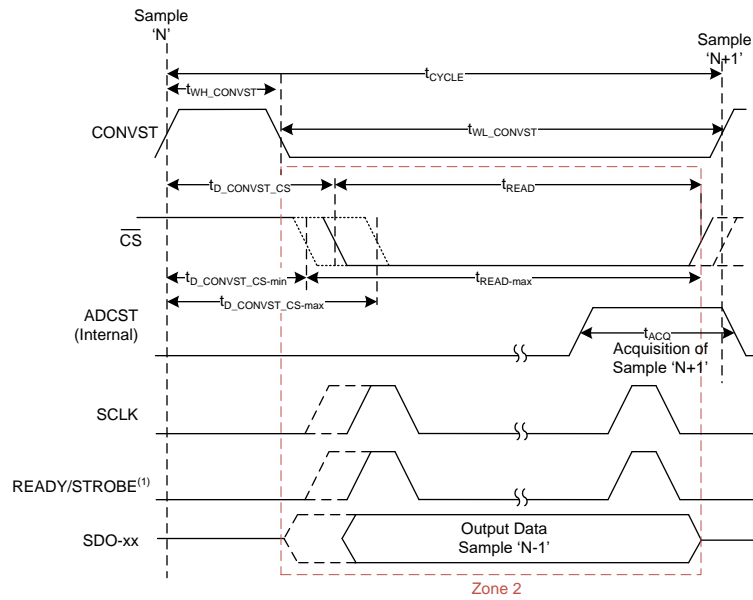

(1) The READY output is not required for zone 2 data transfer. The STROBE output is required only for clock re-timer protocols.

**图 2. Conversion Control and Data Transfer With Wider Read Cycle (Zone 2 Transfer)**

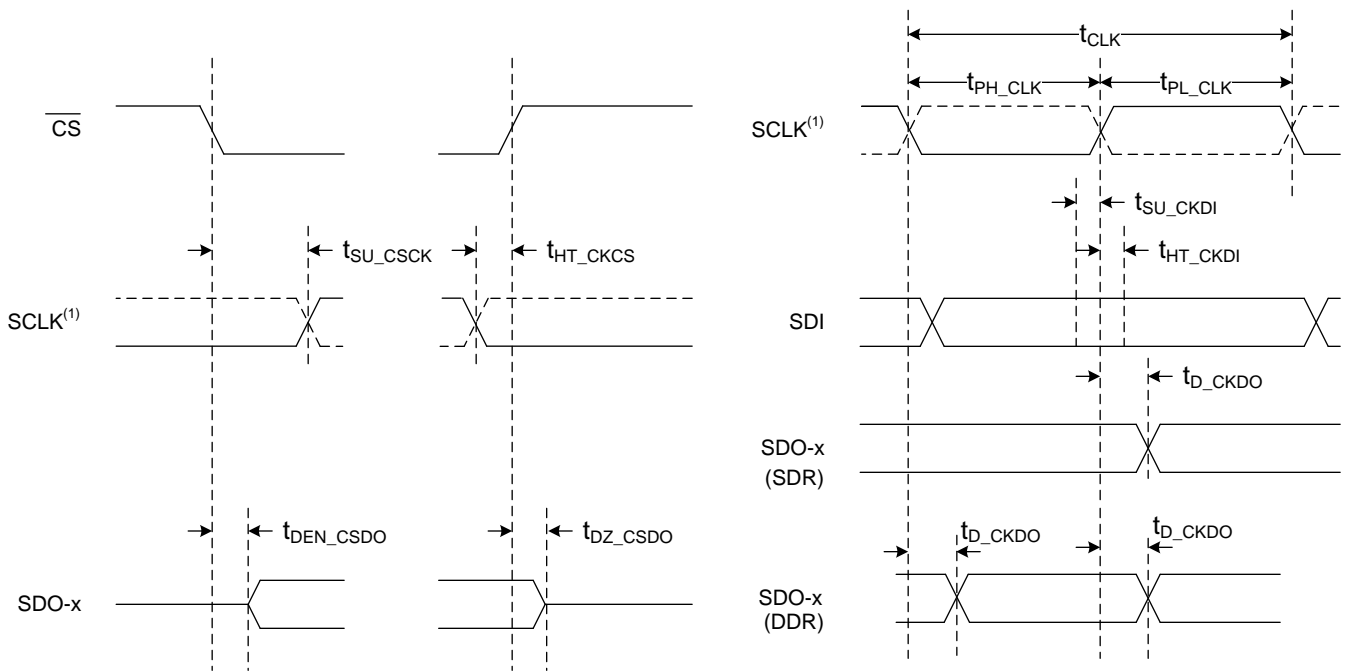

(1) The SCLK polarity, launch edge, and capture edge depend on the SPI protocol selected. DDR is not supported with the parallel byte protocol.

**图 3. SPI-Compatible and Parallel Byte Protocols Timing**



图 4. Clock Re-Timer Protocol (External Clock) Timing



图 5. Clock Re-Timer Protocol (Internal Clock) Timing

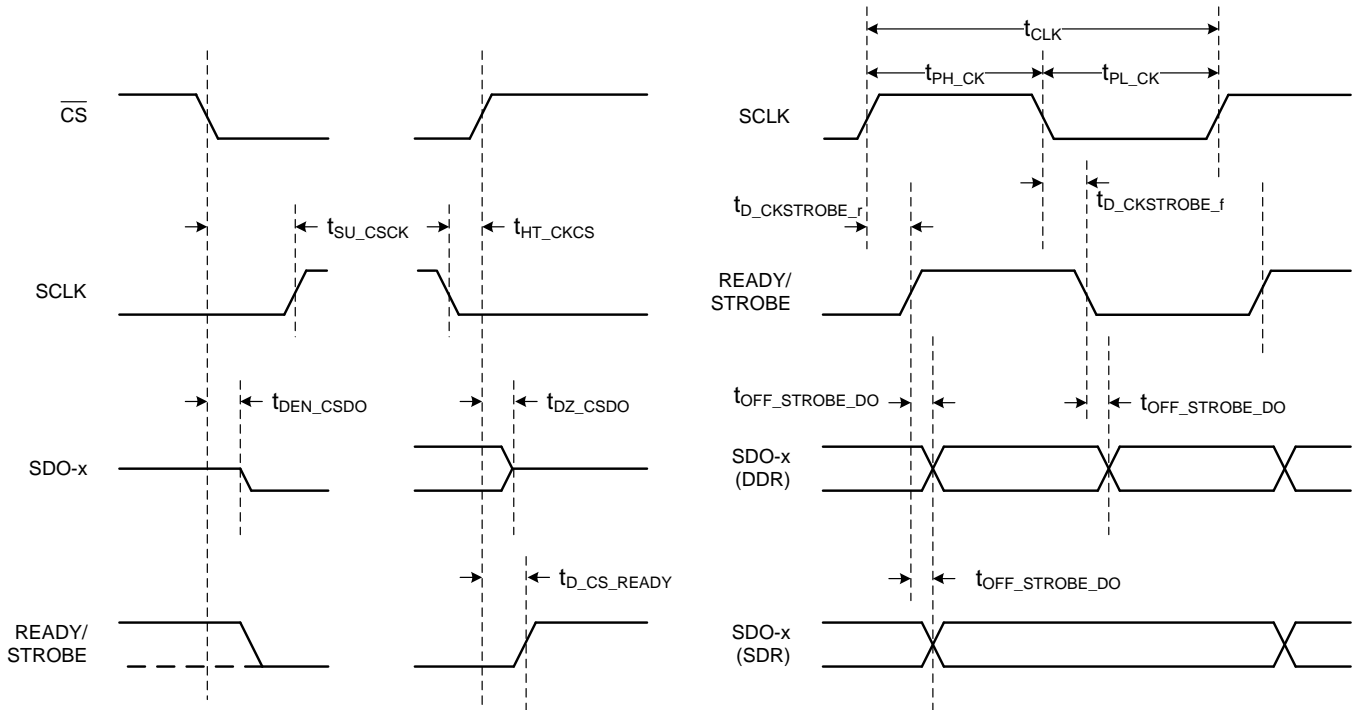

图 6. Asynchronous Reset and Power-Down Timing

### 6.10 Typical Characteristics: ADS9224R

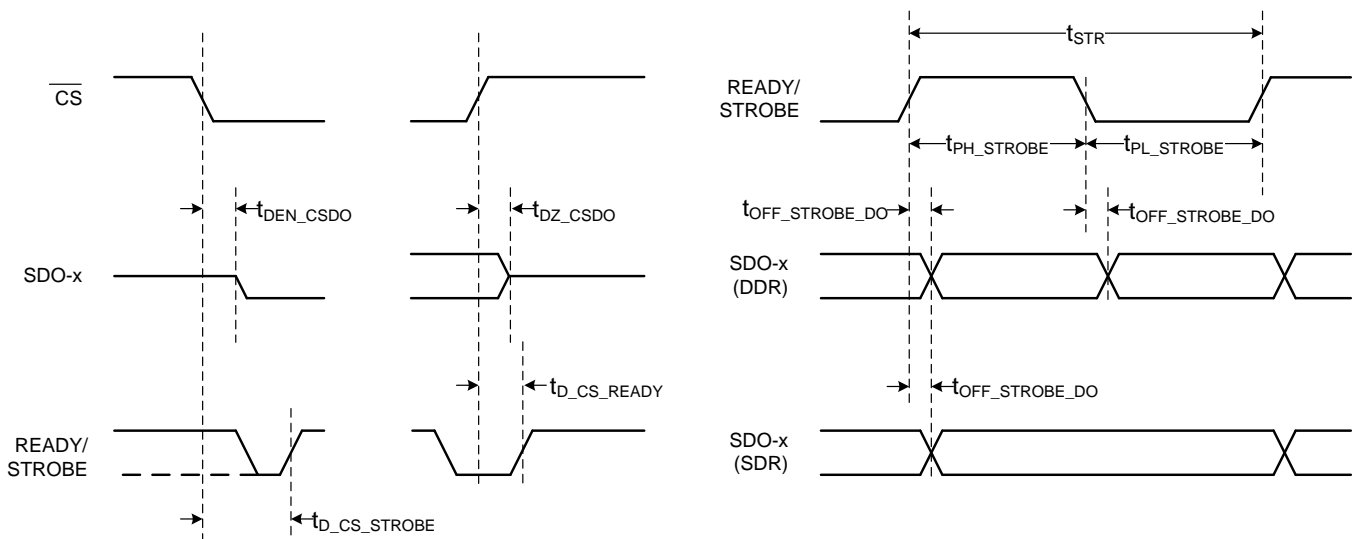

图 7. Typical FFT at  $f_{IN} = 100$  kHz

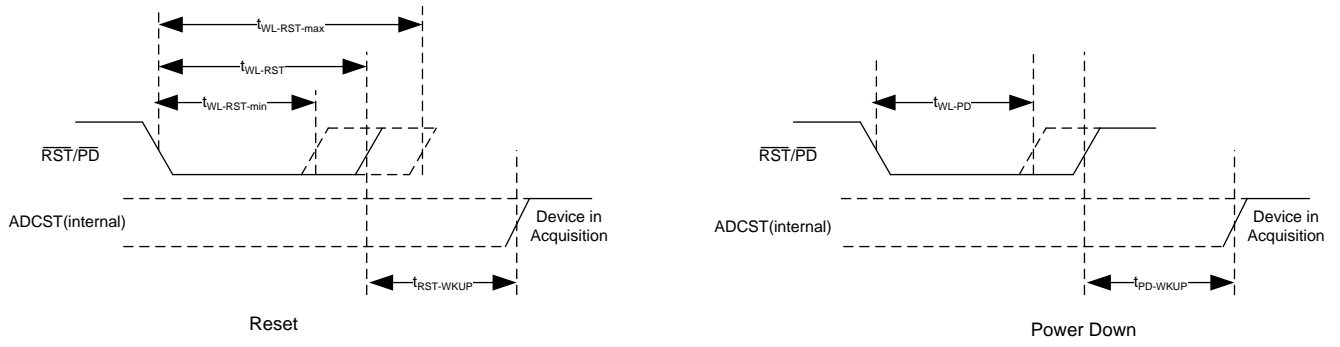

图 8. Typical FFT at  $f_{IN} = 1$  MHz

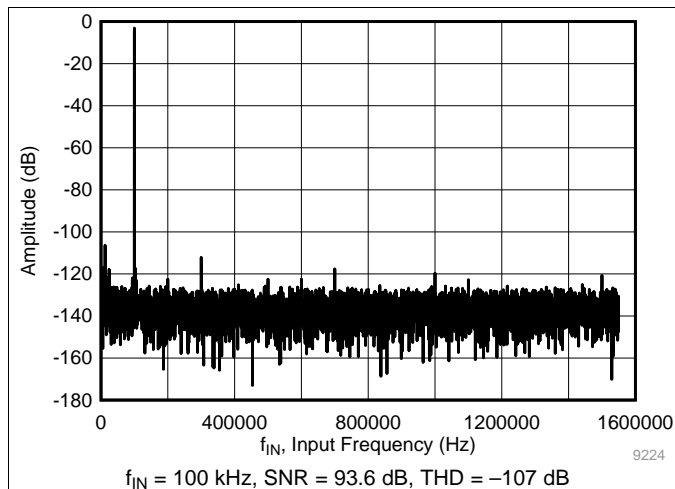

图 9. Noise Performance vs Temperature

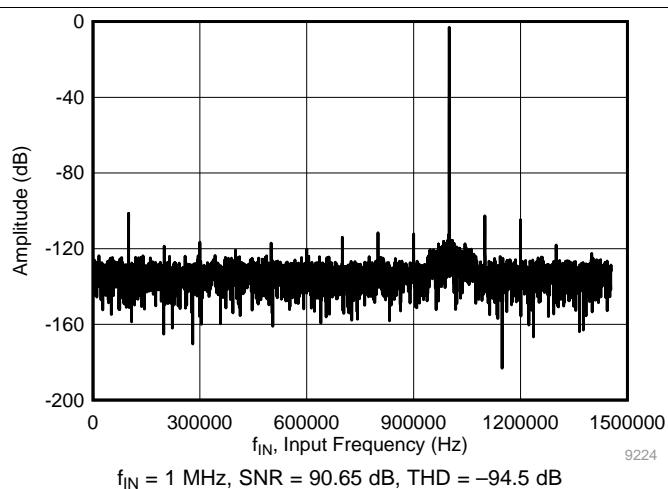

图 10. Noise Performance vs Frequency

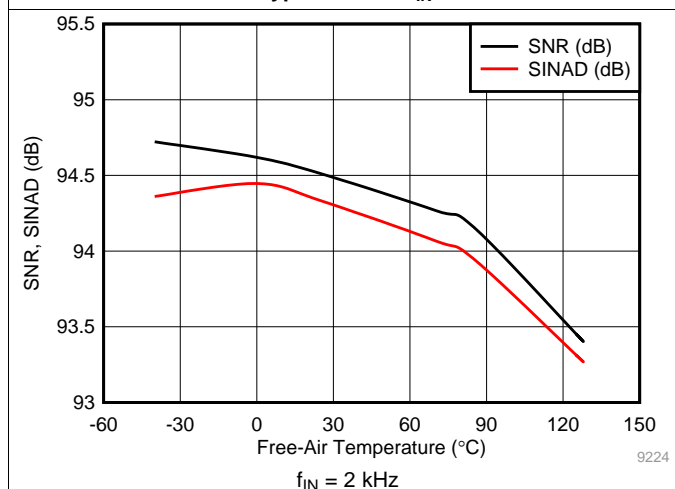

图 11. Distortion Performance vs Temperature

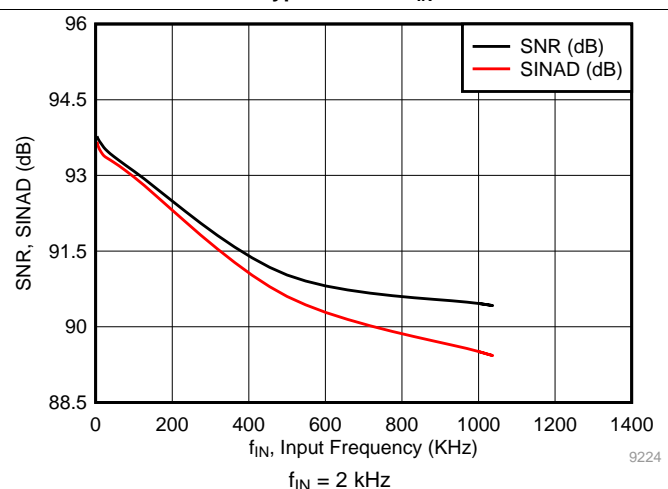

图 12. Distortion Performance vs Frequency

Typical Characteristics: ADS9224R (接下页)

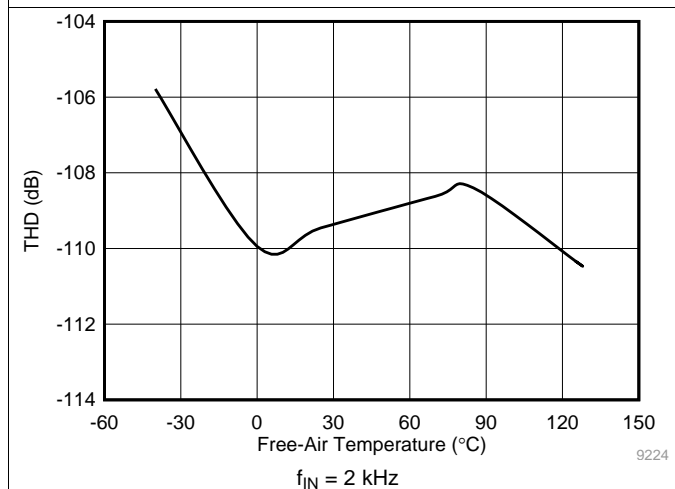

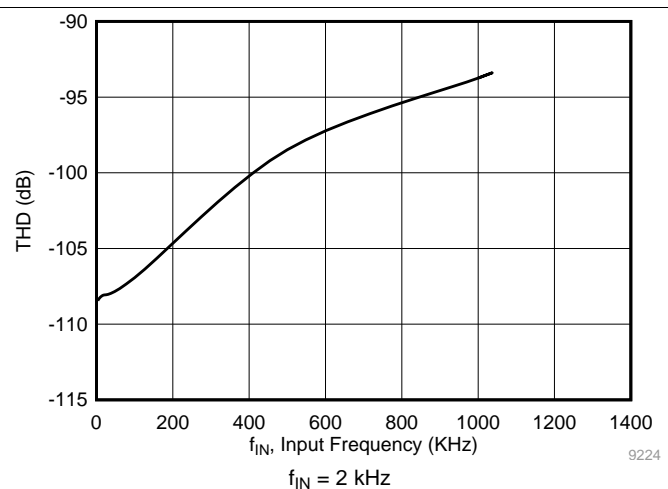
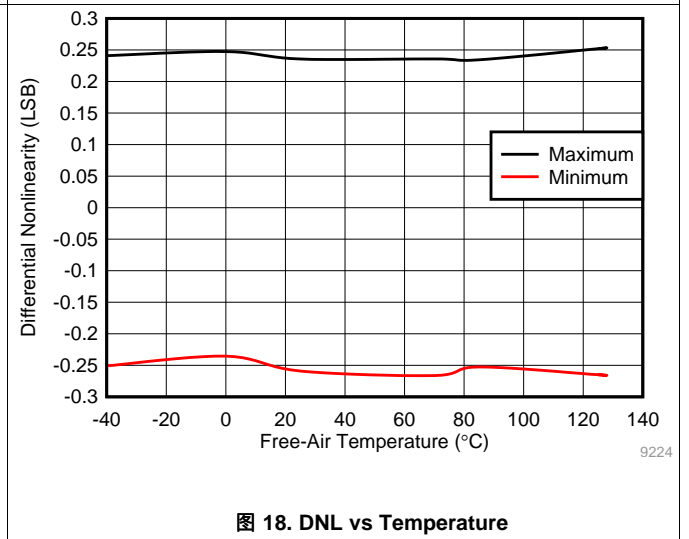
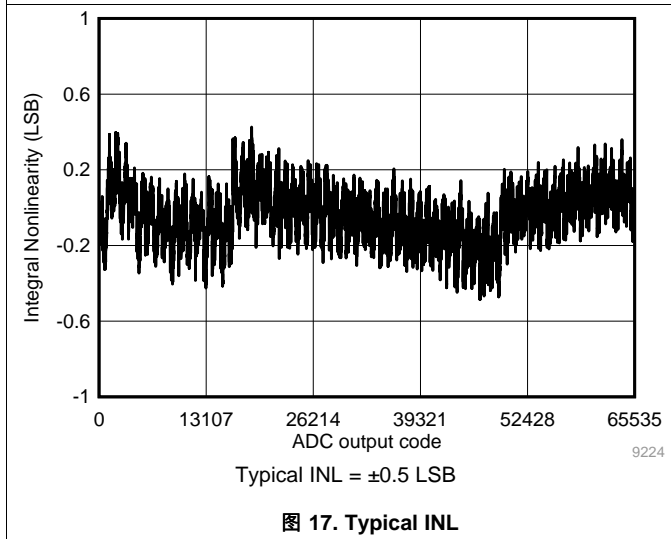
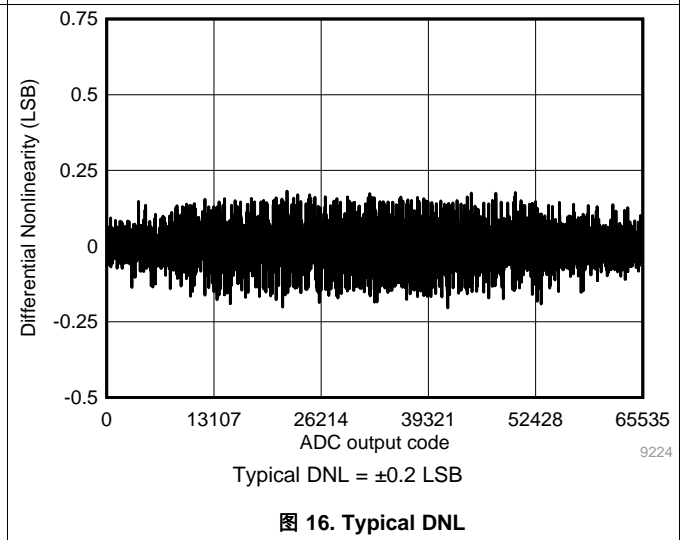
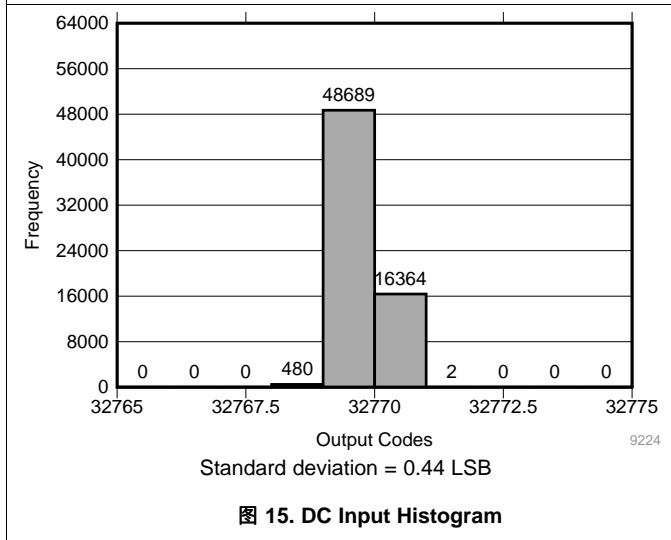
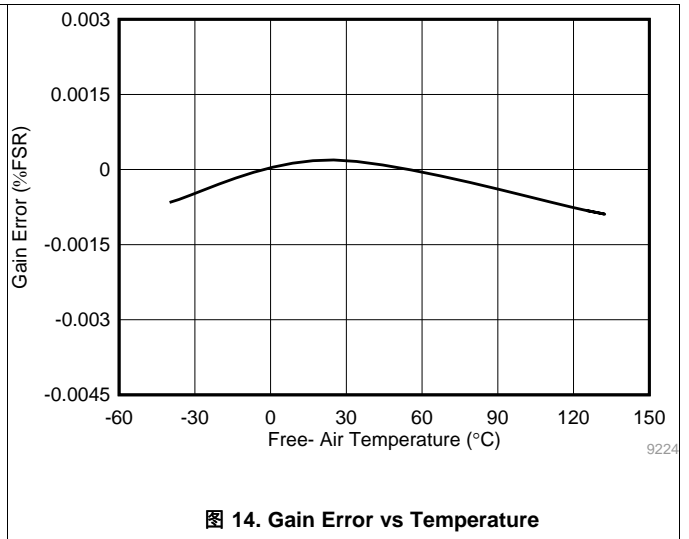
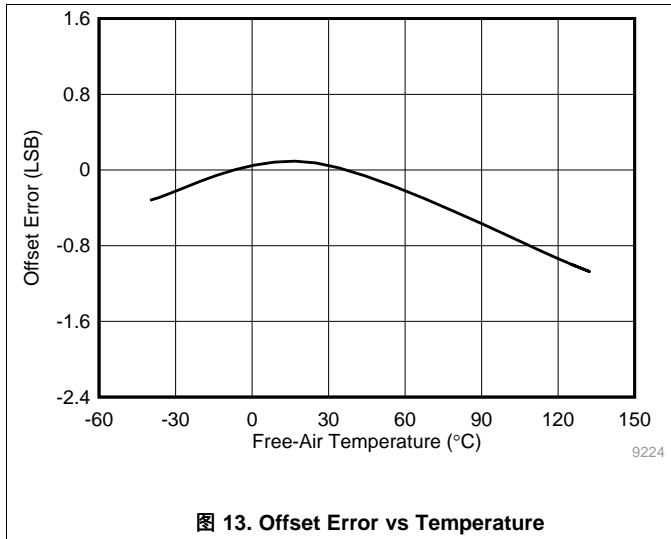

Typical Characteristics: ADS9224R (接下页)

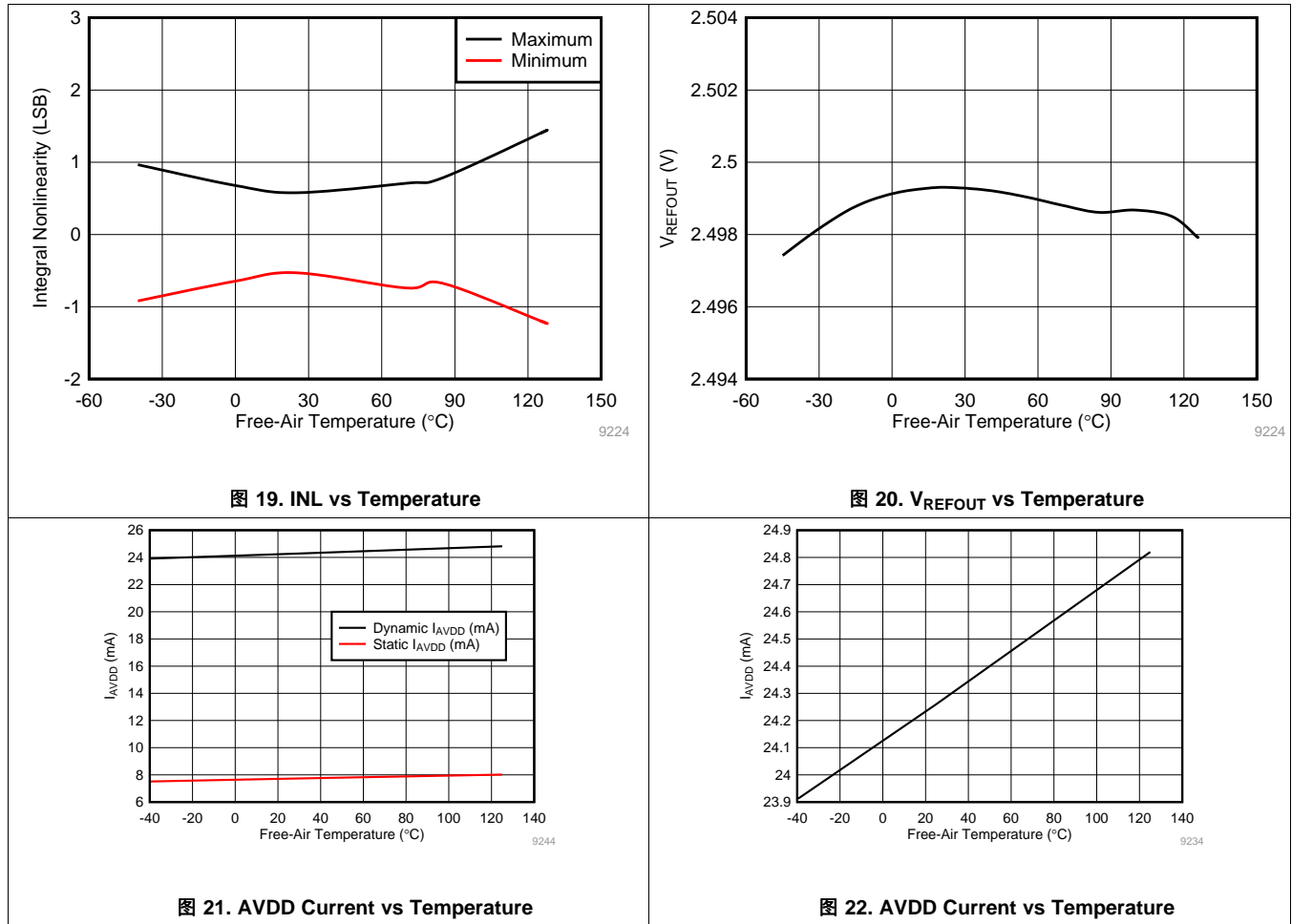

## 6.11 Typical Characteristics: ADS9234R



图 23. Typical FFT at  $f_{IN} = 100 \text{ kHz}$



图 24. Typical FFT at  $f_{IN} = 1 \text{ MHz}$

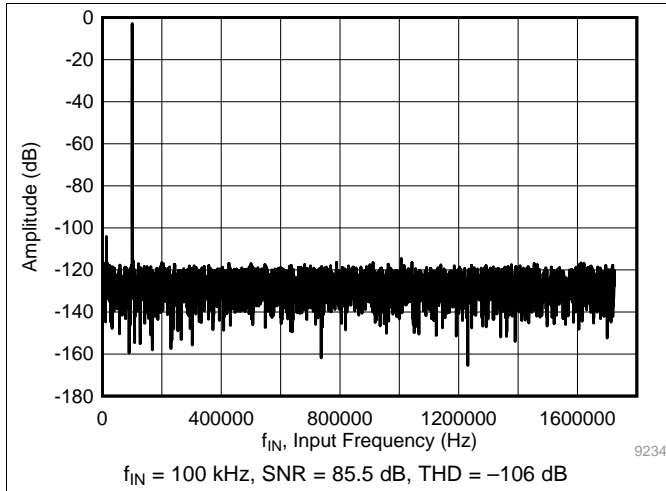

图 25. Noise Performance vs Temperature

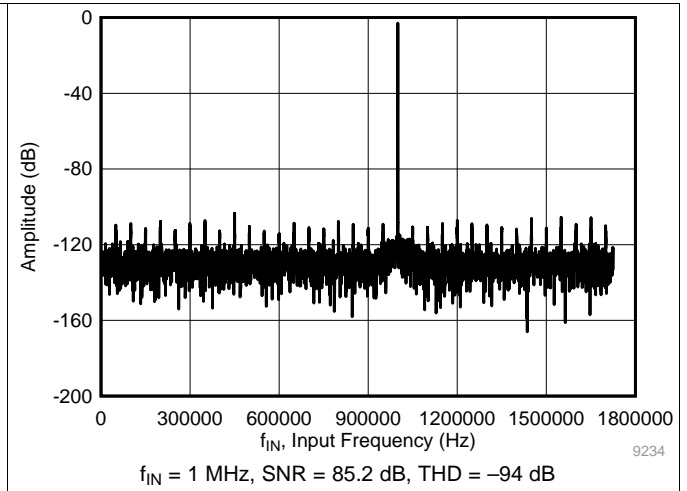

图 26. Noise Performance vs Frequency

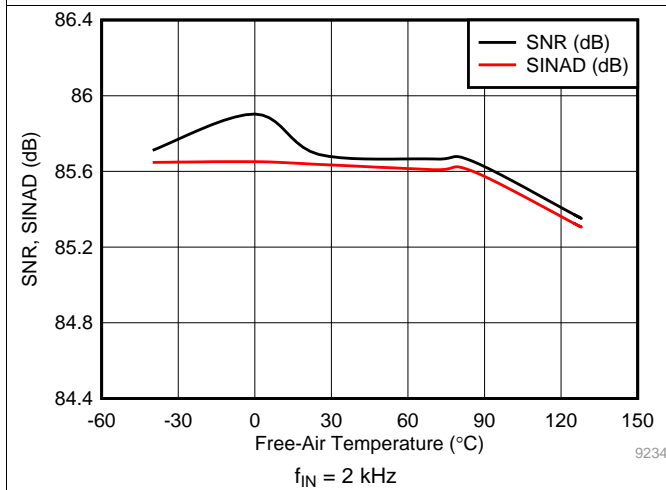

图 27. Distortion Performance vs Temperature

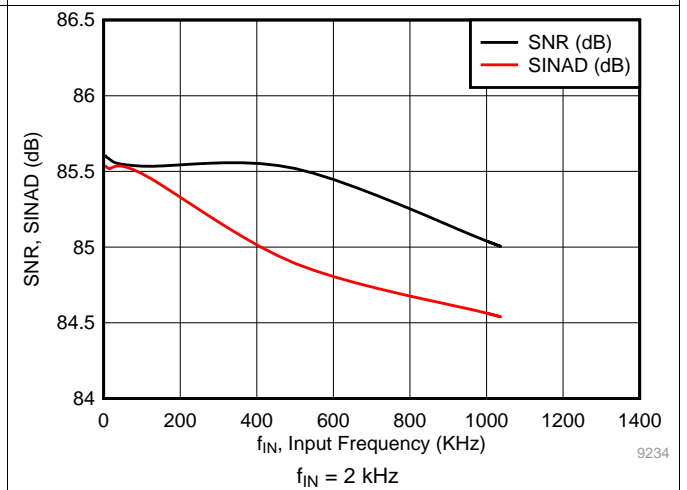

图 28. Distortion Performance vs Frequency

Typical Characteristics: ADS9234R (接下页)

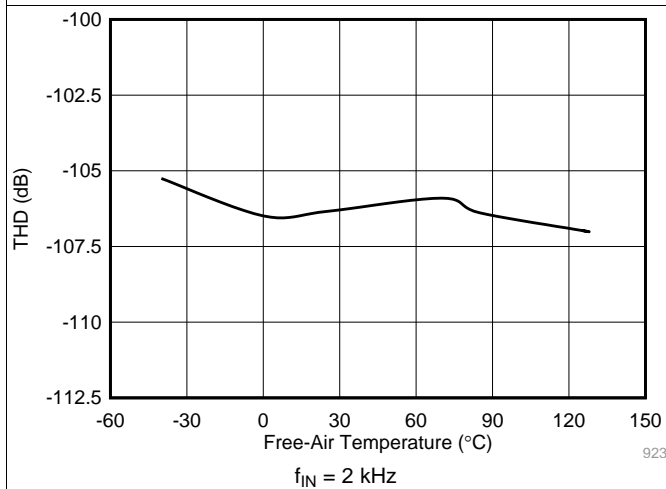

Typical Characteristics: ADS9234R (接下页)

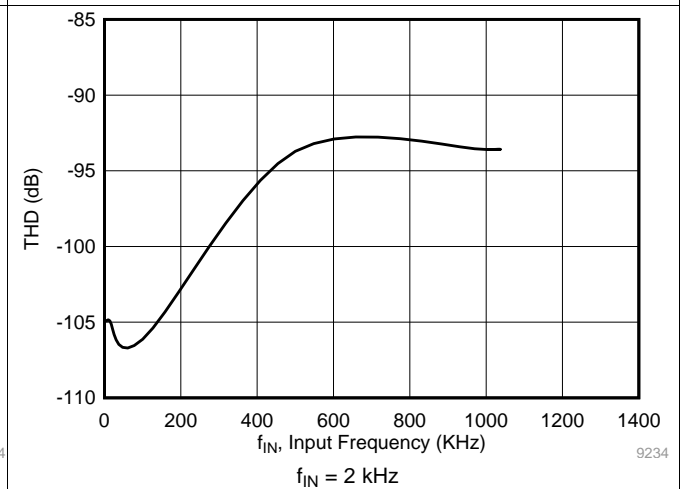
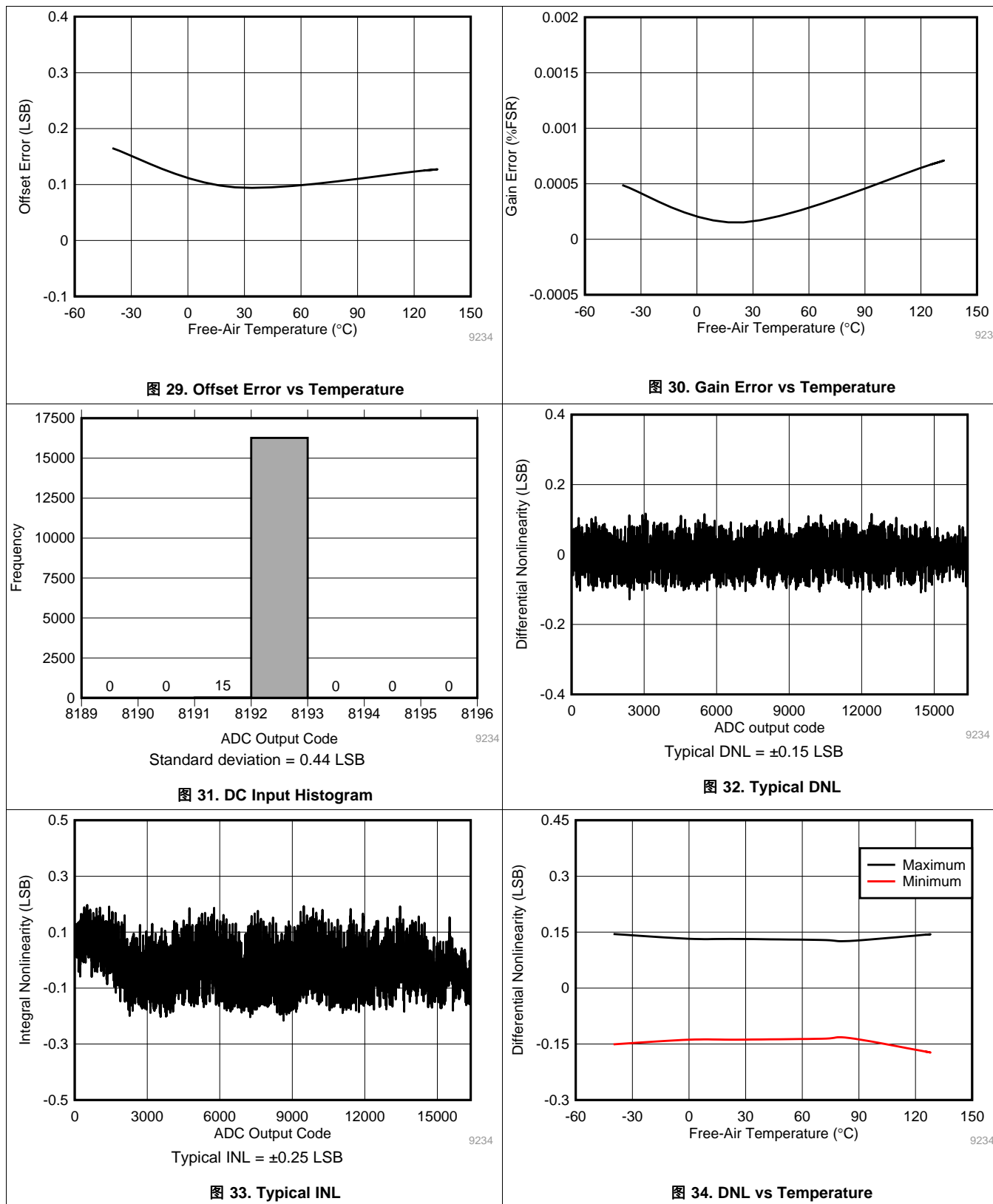
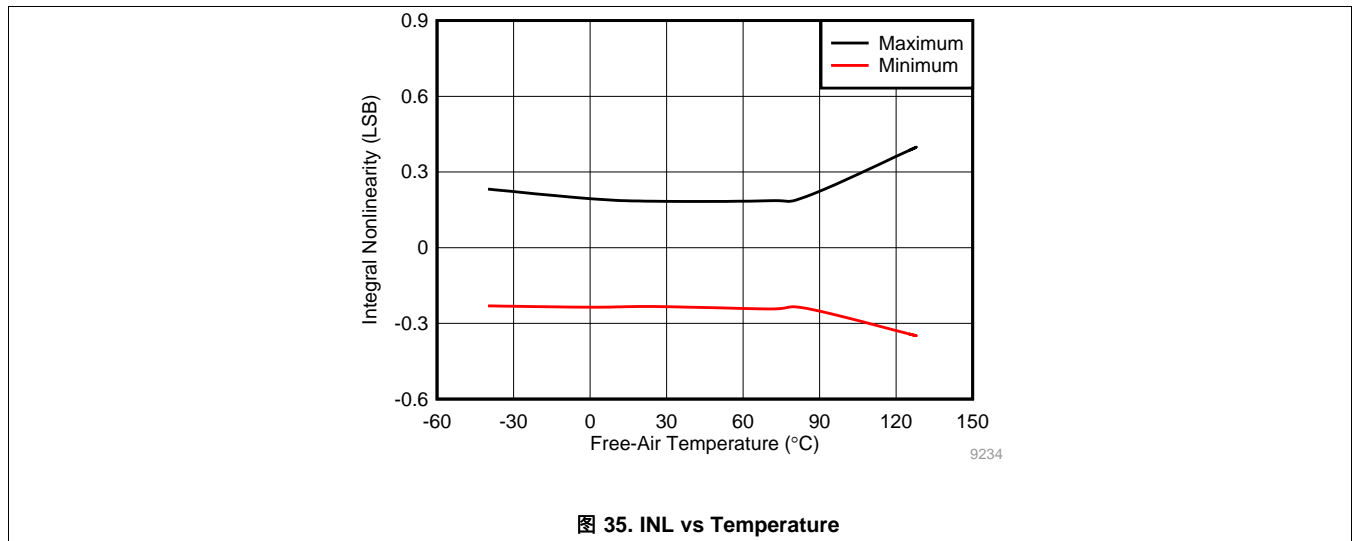

## 7 Detailed Description

### 7.1 Overview

The device belongs to a family of dual, high-speed, simultaneous-sampling, analog-to-digital converters (ADCs). The device supports fully differential input signals and a full-scale input range equal to  $2 \times V_{REFP\_x}$ .

When a conversion is initiated, the difference voltage between the AINP\_x and AINM\_x pins is sampled on the internal capacitor array. The device uses an internal clock to perform conversions. During the conversion process, both analog inputs are disconnected from the sampling capacitors. At the end of conversion process, the device reconnects the sampling capacitors to the AINP\_x and AINM\_x pins and enters an acquisition phase. The device has internal reference and reference buffers to provide the charge required by the ADCs during conversion. The device includes a reference voltage for the ADCs.

The enhanced serial programming interface (eSPI) digital interface is backward-compatible with traditional SPI protocols. eSPI configurable features simplify board layout, timing, and firmware and support high throughput at lower clock speeds, thus allowing an easy interface with a variety of microcontrollers, digital signal processors (DSPs), and field-programmable gate arrays (FPGAs). The device also provides a byte mode and a wide read cycle to reduce the clock frequency required for data transfer. The device includes a clock re-timer (CRT) to ensure data integrity when data are transferred through digital isolators. The device also supports double data rate (DDR) with SPI-compatible serial interface modes and with a clock re-timer.

### 7.2 Functional Block Diagram

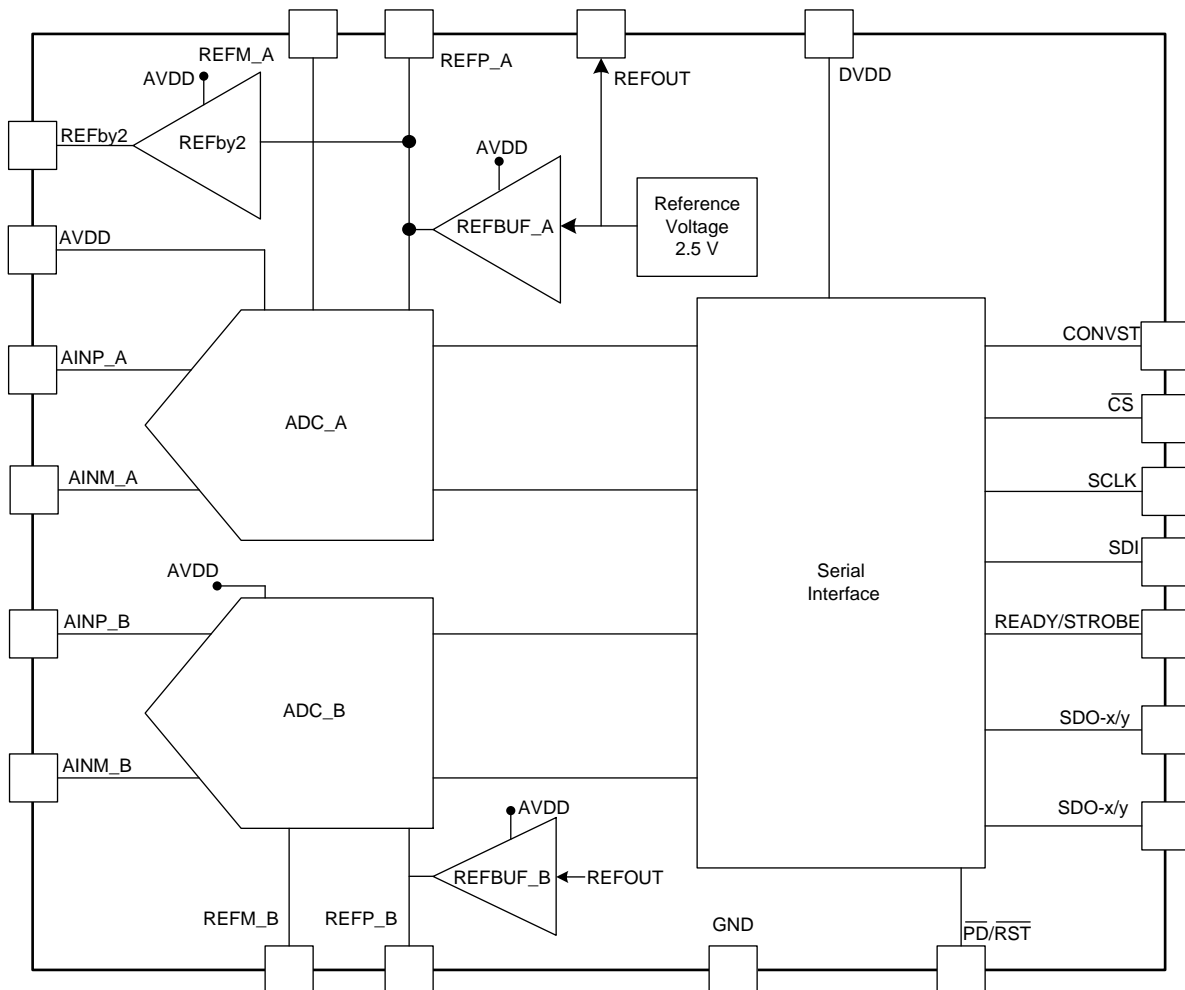

### 7.3 Feature Description

The device is comprised of seven modules: two converters (ADC\_A, ADC\_B), two reference buffers (REFBUF\_A, REFBUF\_B), the REFby2 buffer, the reference voltage, and the serial interface, as shown in the [Functional Block Diagram](#) section.

The converter module samples and converts the analog input into an equivalent digital output code. The reference buffers provide the charge required by the converters for the conversion process. The serial interface module facilitates communication and data transfer between the device and the host controller. The REFby2 buffer provides the common-mode voltage for the amplifiers input driving the analog of the device. The reference voltage is used by the converters for conversion process.

#### 7.3.1 Converter Modules

As shown in [图 36](#), both converter modules sample the analog input signal, compare this signal with the reference voltage (between the pair of REFP\_x and REFM\_x pins), and generate an equivalent digital output code. The converter module receives the PD/RST and CONVST inputs from the interface module, and output the ADCST signal and the conversion result back to the interface module.



图 36. Converter Modules

##### 7.3.1.1 Analog Input With Sample-and-Hold

This device supports unipolar, fully differential, analog input signals. [图 37](#) shows a small-signal equivalent circuit of the sample-and-hold circuit. Each sampling switch is represented by a resistance ( $R_{S1}$  and  $R_{S2}$ , typically 120  $\Omega$ ) in series with an ideal switch ( $SW_1$  and  $SW_2$ ). The sampling capacitors,  $C_{S1}$  and  $C_{S2}$ , are typically 16 pF.

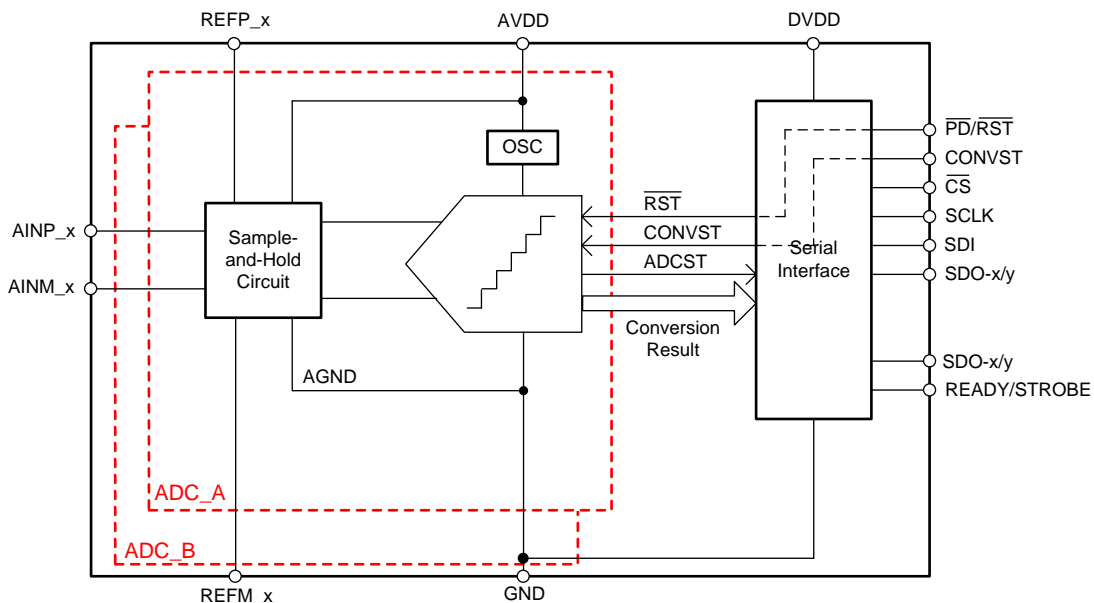

图 37. Analog Input Structure for Converter Module

## Feature Description (接下页)

During the acquisition process, both inputs are individually sampled on  $C_{S1}$  and  $C_{S2}$ , respectively. During the conversion process, both converters convert for the respective voltage difference between the sampled values:  $V_{AINP\_x} - V_{AINM\_x}$ .

公式 1 和 公式 2 provide the full-scale input range (FSR) and common-mode voltage ( $V_{CM}$ ), supported at the analog inputs for reference voltage ( $V_{REFOUT}$ ) on the REFOUT pin.

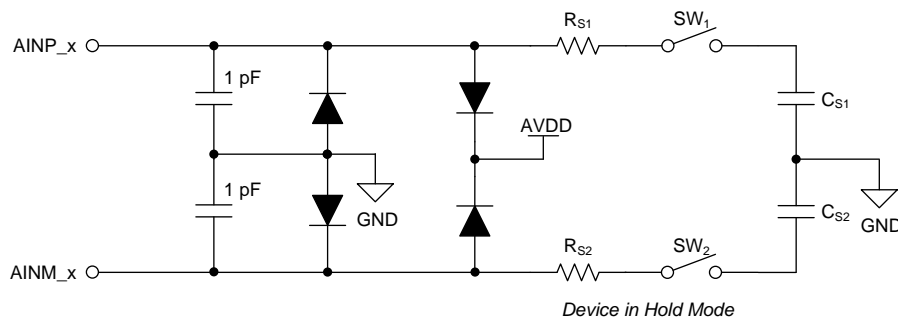
$$FSR = \pm 1.6384 \times V_{REFOUT} = 3.2768 \times V_{REFOUT} \quad (1)$$

$$V_{CM} = 0.8192 \times V_{REFOUT} \pm 0.2 \text{ V} \quad (2)$$

### 7.3.1.2 ADC Transfer Function

The device output is in two's complement format. 表 1 和 图 38 show the ideal transfer characteristics for the device. 公式 3 gives the least significant bit (LSB) for the ADC.

$$1 \text{ LSB} = FSR / 2^R$$

where

- FSR is defined in 公式 1
- R = Resolution of the device



图 38. Ideal Transfer Characteristics

表 1. Transfer Characteristics

STEP	INPUT VOLTAGE (AINP_x-AINM_x)	CODE	DESCRIPTION	IDEAL OUTPUT CODE (R = 16)	IDEAL OUTPUT CODE (R = 14)
A	$\leq -(1.6384 \times V_{REFOUT} - 1 \text{ LSB})$	NFSC	Negative full-scale code	8000	2000
B	0 LSB to 1 LSB	MC	Mid code	0000	0000
C	$\geq (1.6384 \times V_{REFOUT} - 1 \text{ LSB})$	PFSC	Positive full-scale code	7FFF	1FFF

### 7.3.2 Internal Reference Voltage

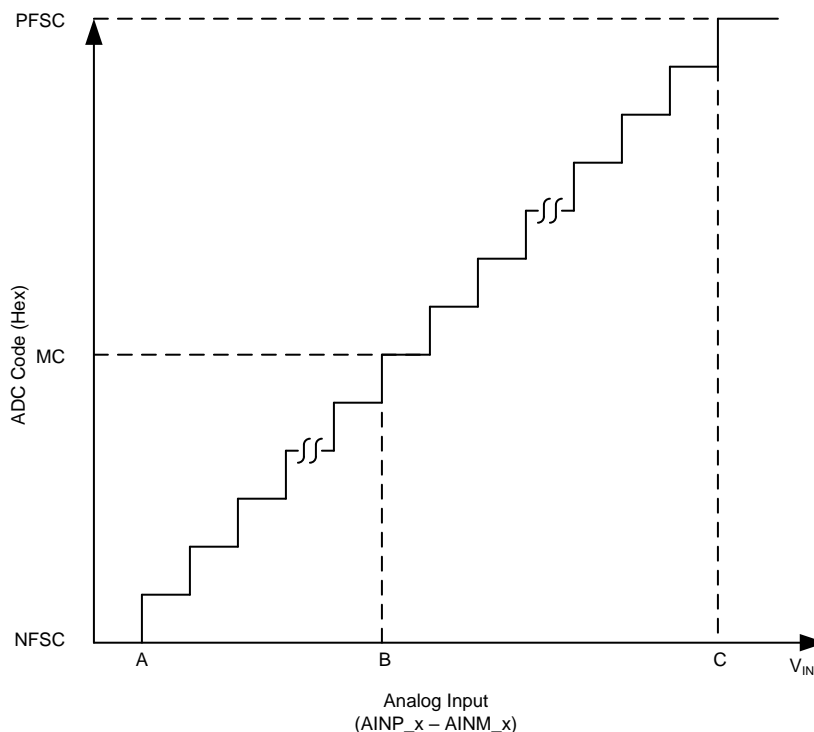
The device features an internal reference source with a nominal output value of 2.5 V. The ADC internal reference voltage is brought out on the REFOUT pin. A 1- $\mu$ F decoupling capacitor ( $C_{REFOUT}$ ), as shown in 图 39, is recommended to be placed between the REFOUT pin and GND pin. The capacitor must be placed as close to the REFOUT pin as possible. The output impedance of the internal band-gap circuit creates a low-pass filter with this capacitor to band-limit the noise of the reference. The initial accuracy specification for the internal reference can be degraded if the die is exposed to any mechanical or thermal stress. Heating the device when being soldered to a printed circuit board (PCB) and any subsequent solder reflow is a primary cause for shifts in the  $V_{REF}$  value.

All performance characteristics of the device are specified with the internal reference buffer and a specified value of  $C_{REFP\_x}$ . As shown in 图 39, place a decoupling capacitor  $C_{REFP\_x}$  between the REFP\_x and REFM\_x pins as close to the device as possible.



图 39. Connection Diagram for Reference and Reference Buffers

### 7.3.3 Reference Buffers

On the CONVST rising edge, both converters start converting the sampled value on the analog input, and the internal capacitors are switched to the REFP\_x pins. Most of the switching charge required during the conversion process is provided by the external decoupling capacitor  $C_{REFP\_x}$ . If the charge lost from  $C_{REFP\_x}$  is not replenished before the next CONVST rising edge, the subsequent conversion occurs with this different reference voltage and causes a proportional error in the output code. To eliminate these errors, the internal reference buffers of the device maintains the voltage on the REFP\_x pins. The reference buffers have a gain of  $G_{REFBUF}$ , as specified in the [Specifications](#) section. The voltage at the REFP\_x pins can be calculated as  $V_{REFP\_x} = G_{REFBUF} \times V_{REFOUT}$ .

### 7.3.4 REFby2 Buffer

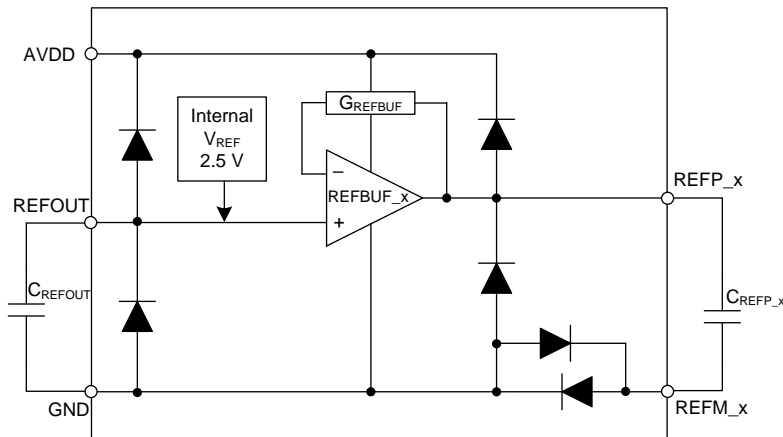
The device includes a REFby2 buffer for setting the common-mode voltage required by the converter modules. The REFby2 output can be used to drive the  $V_{OCM}$  common-mode input pin of the fully differential amplifiers (similar to the THS4551). The REFby2 output can be increased by 100 mV (for specifications of the REFby2 output, see the [Specifications](#) section) for providing headroom from GND for the fully differential amplifier. To increase the REFby2 output, set the EN\_REFby2\_OFFSET bit to 1 in the REFby2\_OFFSET register. 图 40 depicts a block diagram for the REFby2 buffer.



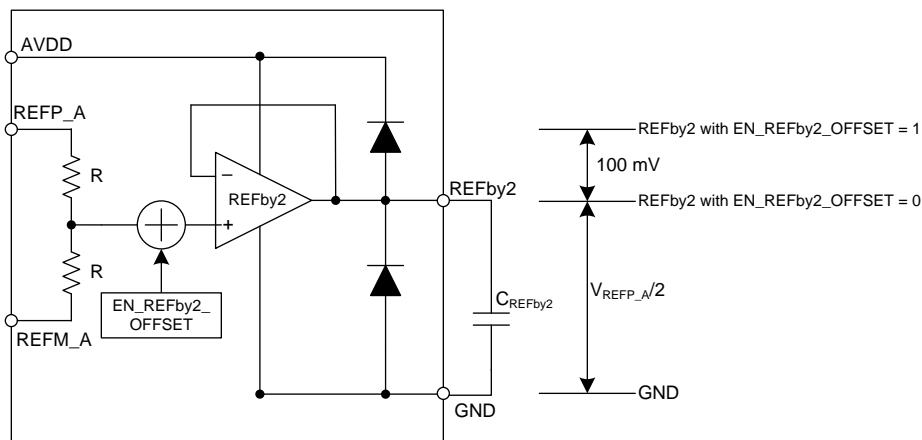

Copyright © 2017, Texas Instruments Incorporated

图 40. REFby2 Buffer

### 7.3.5 Data Averaging

The device can be configured to average two or four samples and provide the averaged value as output data. To configure the data averaging, configure the [DATA\\_AVG\\_CFG register](#).

#### 7.3.5.1 Averaging of Two Samples

To enable averaging of two samples, set the EN\_DATA\_AVG bits in the [DATA\\_AVG\\_CFG register](#) to 10b. In this mode, the device averages two samples and provides the average of two samples as output data. The output data rate reduces by a factor of two. In this mode, the host must provide two pulses separated by a time of  $t_{CYCLE}$  (see  $t_{CYCLE}$  for a zone 2 transfer in the [Specifications](#) section) on the CONVST pin. The device sets the READY pin high after a time of  $t_{DRDY}$  (see  $t_{DRDY}$  in the [Specifications](#) section) from the second rising edge on the CONVST pin. After the READY pin is set high, the host can read the data by using one of the [protocols for reading from the device](#). The host can read the data while providing the two CONVST pulses for acquiring the next two samples. The host must keep  $t_{READ} < [2 \times t_{CYCLE}]$ . 图 41 provides the timing for the averaging of two samples.



图 41. Timing for Averaging of Two Samples

### 7.3.5.2 Averaging of Four Samples

To enable averaging of four samples, set the EN\_DATA\_AVG bits in the DATA\_AVG\_CFG register to 11b. In this mode, the device averages four samples and provides the average of four samples as output data. The output data rate reduces by a factor of four. In this mode, the host must provide four pulses separated by a time of  $t_{\text{CYCLE}}$  (see  $t_{\text{CYCLE}}$  for a zone 2 transfer in the [Specifications](#) section) on the CONVST pin. The device sets the READY pin high after a time of  $t_{\text{DRDY}}$  (see  $t_{\text{DRDY}}$  in the [Specifications](#) section) from the fourth rising edge on the CONVST pin. After the READY pin is set high, the host can read the data by using one of the [protocols for reading from the device](#). The host can read the data while providing the four CONVST pulses for acquiring the next four samples. The host must keep  $t_{\text{READ}} < [4 \times t_{\text{CYCLE}}]$ . [图 42](#) provides the timing for the averaging of four samples.

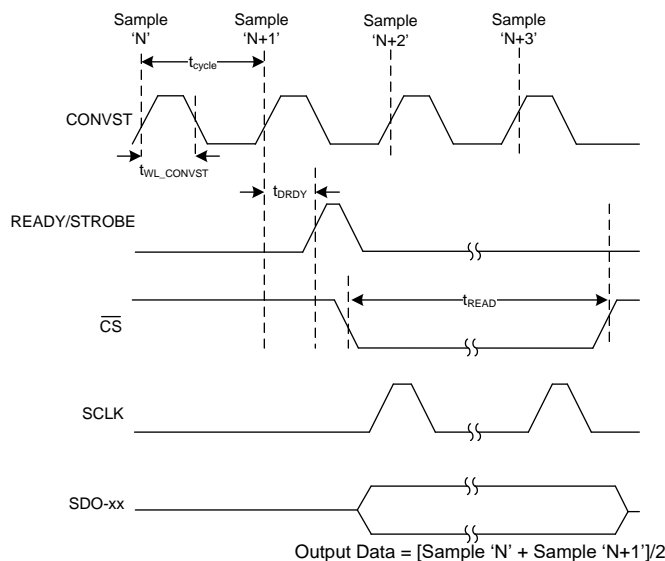

图 42. Timing for Averaging of Four Samples

## 7.4 Device Functional Modes

This device supports three functional states: RST or power-down, ACQ, and CNV. The device state is determined by the status of the CONVST and  $\overline{\text{PD/RST}}$  control signals provided by the host controller.

### 7.4.1 ACQ State

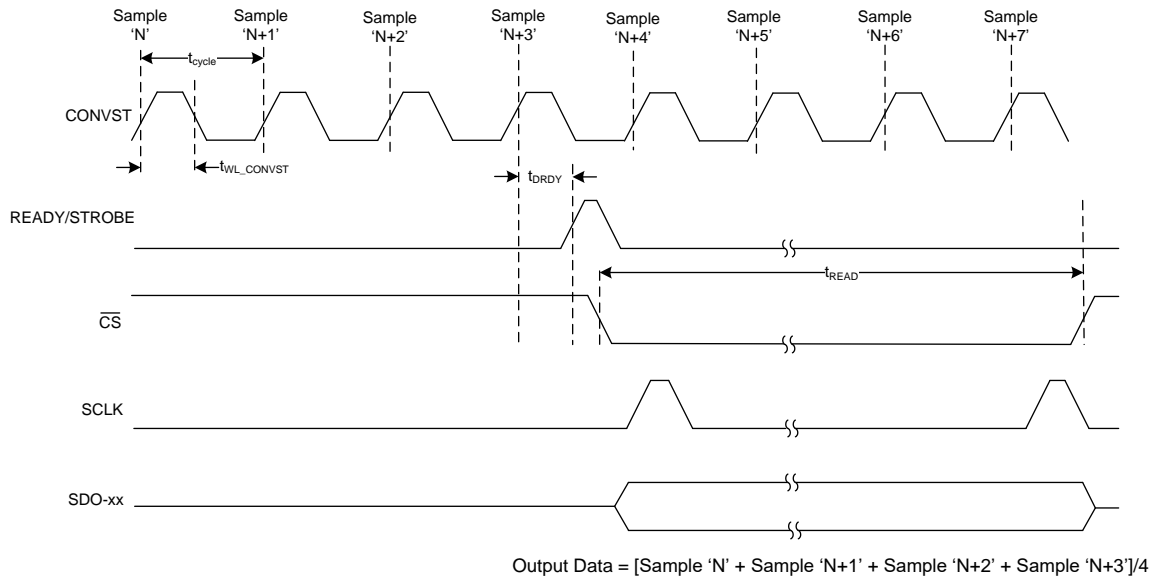
In ACQ state, the device acquires the analog input signal. The device enters ACQ state at power-up, when coming out of power down, after any asynchronous reset, and by the ADCST signal (internal). A  $\overline{\text{PD/RST}}$  falling edge takes the device from ACQ state to RST state. A CONVST rising edge takes the device from ACQ state to CNV state.

### 7.4.2 CNV State

The device moves from ACQ state to CNV state and starts conversion on a rising edge of a CONVST pin. The conversion process uses an internal clock. The host must provide a minimum time of  $t_{\text{CYCLE}}$  between two subsequent start of conversions.

### 7.4.3 Reset or Power-Down

The  $\overline{\text{PD/RST}}$  pin is an asynchronous digital input for the device. The pulse duration (low) on the  $\overline{\text{PD/RST}}$  pin decides the state for the device (reset or power-down). [图 43](#) provides the timing diagram for these states. On power-up or after reset the device supports the SPI-00-S protocol for configuring the device and the SPI-00-S-SDR protocol for reading the data from the device. See the [Protocols for Reading From the Device](#) and [Protocols for Configuring the Device](#) sections for details.

## Device Functional Modes (接下页)



图 43. Reset or Power Down

### 7.4.3.1 Reset

To enter reset state, the host controller pulls and keeps the  $\overline{\text{PD}}/\overline{\text{RST}}$  pin low for a duration of  $t_{\text{WL\_RST}}$  ( $t_{\text{WL\_RST-min}} \leq t_{\text{WL\_RST}} \leq t_{\text{WL\_RST-max}}$ ).

In reset state, the device terminates the ongoing conversion or acquisition process and all configuration registers (see the [Register Maps](#) section) are reset to their default values.

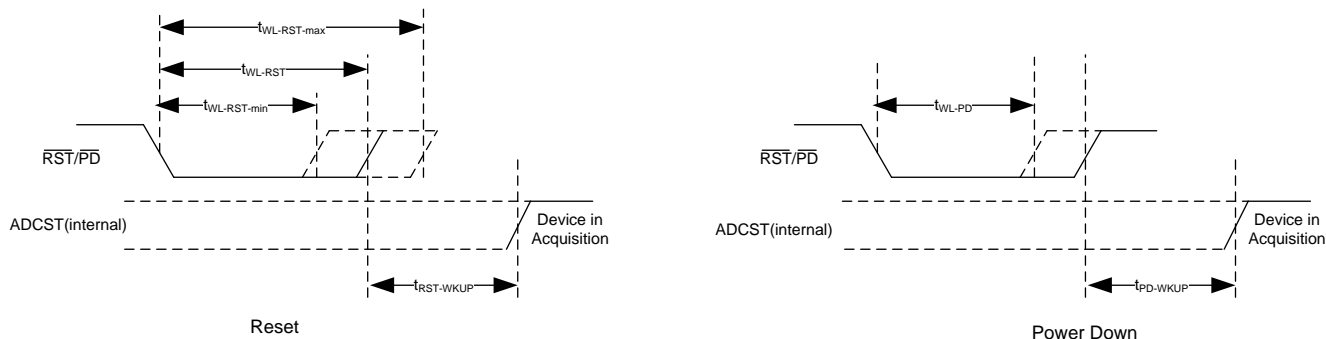
After a delay of  $t_{\text{RST-WKUP}}$ , the device enters ACQ state.

### 7.4.3.2 Power-Down

To enter power-down state, the host controller pulls and keeps the  $\overline{\text{PD}}/\overline{\text{RST}}$  pin low for a minimum duration of  $t_{\text{WL\_PD}}$ .

In power-down state, all device blocks are powered down and all configuration registers (see the [Register Maps](#) section) are reset to their default values.

To exit power-down state, the host controller pulls the  $\overline{\text{PD}}/\overline{\text{RST}}$  pin high. After a delay of  $t_{\text{PD-WKUP}}$ , the device powers up and enters ACQ state.

## Device Functional Modes (接下页)

### 7.4.4 Conversion Control and Data Transfer Frame

The device supports two modes of conversion control and data transfer, one with zero cycle latency (zone 1 transfer) and another with a wide read cycle (zone 2 transfer).

#### 7.4.4.1 Conversion Control and Data Transfer Frame With Zero Cycle Latency (Zone 1 Transfer)

In this mode of conversion control and data transfer, the device starts conversion on the rising edge of CONVST. The CONVST pin can be pulled low after a minimum time of  $t_{WH\_CONVST}$ . After the conversion is finished, the rising edge of the READY/STROBE pin indicates that the data are ready and the data can be read by the host. After the READY pin is set high, as shown in 图 44, the host must pull CS low and provide clocks on the SCLK pin to read the data in zone 1 without cycle latency. For a zone 1 transfer, the host must provide a minimum delay time of  $t_{D\_CONVST\_CS}$  ( $= t_{DRDY}$ ) between the rising edge of CONVST and the falling edge of CS.

The data for the present sample (sample N) is provided by the device on the SDO pins. After all bits are read, the host can pull the CS pin high to end the data transfer frame. After pulling CS high, the host can pull the CONVST pin high to start the next conversion. The host must keep the SDI pin low (NOP0) or high (NOP1) for conversion control and for getting conversion results from the device. In this mode of conversion control, the time between two adjacent rising edges of the CONVST signal ( $t_{CYCLE}$ ) is determined as  $t_{CYCLE} = t_{DRDY} + t_{READ}$ .

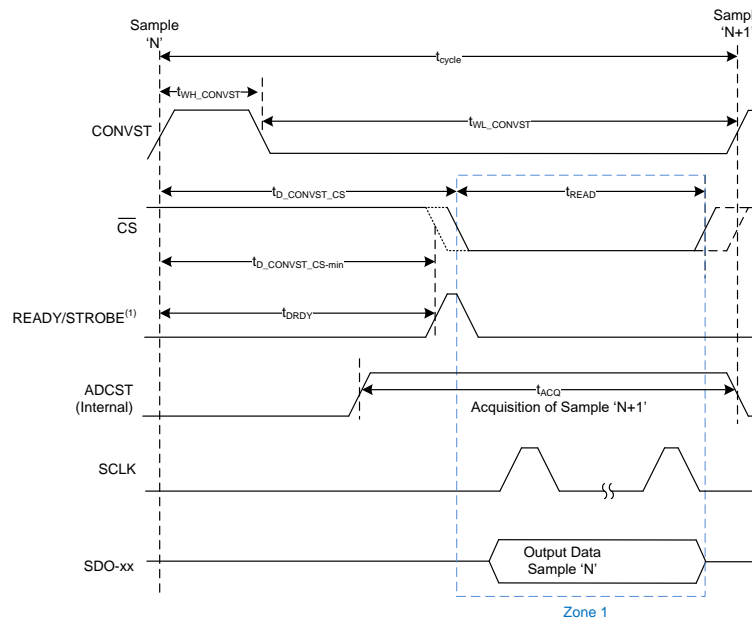

- (1) The READY output is required for data transfer with zero cycle latency. The STROBE output is required only for clock re-timer (CRT) protocols. See the [READY/STROBE Output](#) section for details.
- (2) For  $t_{READ}$  with different data transfer protocols; see the [Protocols for Reading From the Device](#) section.
- (3)  $f_{Sample} = 1 / t_{cycle}$ .

图 44. Conversion Control and Data Transfer Frame With Zero Cycle Latency (Zone 1 Transfer)

## Device Functional Modes (接下页)

### 7.4.4.2 Conversion Control and Data Transfer Frame With Wide Read Cycle (Zone 2 Transfer)

In this mode of conversion control and data transfer, the device starts conversion on the rising edge of CONVST. The CONVST pin can be pulled low after a minimum time of  $t_{WH\_CONVST}$ . After a time of  $t_{D\_CONVST\_CS}$  (see  $t_{D\_CONVST\_CS}$  for zone 2 transfer in the [Specifications](#) section), the host must pull  $\overline{CS}$  low and provide clocks on the SCLK pin to read the data in zone 2. As shown in [图 45](#), a zone 2 transfer provides more read time ( $t_{read}$ ). The read time available for reading data is maximized when  $t_{D\_CONVST\_CS}$  is set to the minimum permissible value. The data for the previous sample (sample N-1) is provided by the device on the SDO pins. After all bits are read, the host can pull the  $\overline{CS}$  pin high to end the data transfer frame. After pulling  $\overline{CS}$  high, the host can pull the CONVST pin high to start the next conversion. In this mode of conversion control, a minimum time of  $t_{CYCLE}$  (see  $t_{CYCLE}$  for zone 2 transfer in the [Specifications](#) section) is required between two adjacent rising edges of the CONVST signal. The host must keep the SDI pin low (NOP0) or high (NOP1) for conversion control and for getting conversion results from the device.

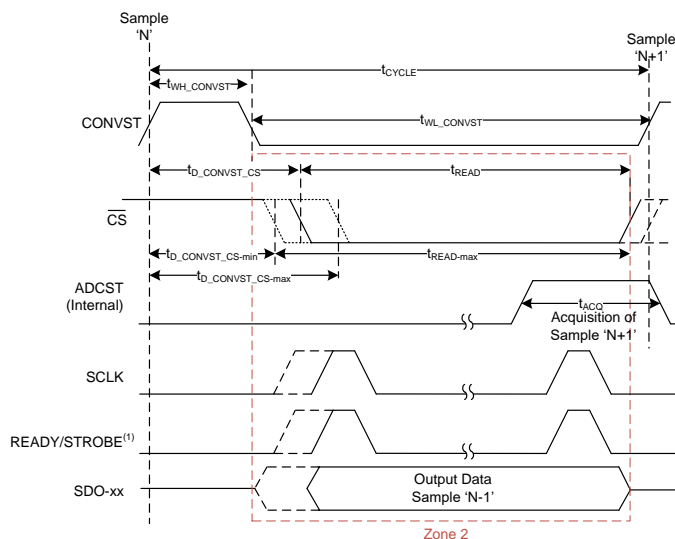

- (1) The READY output is not required for zone 2 data transfer. The STROBE output is required only for clock re-timer (CRT) protocols. See the [READY/STROBE Output](#) section for details.
- (2) For  $t_{READ}$  with different data transfer protocols; see the [Protocols for Reading From the Device](#) section.
- (3)  $f_{Sample} = 1 / t_{cycle}$ .

**图 45. Conversion Control and Data Transfer Frame With Wide Read Cycle (Zone 2 Transfer)**

#### 注

For optimum performance with zone 2 transfer, TI recommends masking the READY output by setting the READY\_MASK bit in the [OUTPUT\\_DATA\\_WORD\\_CFG](#) register and using a data transfer protocol with a bus width of more than 2 SDOs or the parallel byte protocol to keep  $[t_{D\_CONVST\_CS} + t_{READ}]$  below 150 ns. See the [Protocols for Reading From the Device](#) section for details on different protocols for reading the data.

## 7.5 READY/STROBE Output

The **READY/STROBE** pin has multiple functions. The **READY** and **STROBE** signals are multiplexed to this pin. When  $\overline{CS}$  is low, **STROBE** is output and when  $\overline{CS}$  is high, **READY** is output.

### 7.5.1 READY Output

After power-up or after exiting power-down (a rising edge on  $\overline{PD}/\overline{RST}$ ), the **READY** signal is set high. After a time of 0.9 ms, this signal goes low, indicating that the device is initialized and the registers can be configured. However, conversions can be performed with the desired accuracy only after a time of  $t_{PD-WKUP}$  (see the [Specifications](#) section). After power-up, for a zone 1 transfer (see [Figure 44](#)), the device starts conversion on the **CONVST** rising edge and the **READY** pin remains low during the conversion process. After a time of  $t_{DRDY}$ , the conversion process completes, **READY** is set high, and data can be read by the host. The host can read data by bringing  $\overline{CS}$  high and by providing clocks on **SCLK**. After  $\overline{CS}$  is brought low, **READY** is set low. For a zone 2 transfer, TI recommends masking the **READY** output by setting the **READY\_MASK** bit in the **OUTPUT\_DATA\_WORD\_CFG** register.

### 7.5.2 STROBE Output

In clock re-timer protocols, the device sends out data on the **SDO** lines with synchronized clock on the **STROBE** line. The data are synchronized to the rising edge of the **STROBE** pulses. In CRT protocols, the host can use the **STROBE** output for latching the data. The **STROBE** for the CRT protocols is either derived from the external **SCLK** provided by the host or from the internal oscillator. The **STROBE** signal is held low for protocols other than the CRT protocols.

## 7.6 Programming

### 7.6.1 Output Data Word

The output data word, as shown in [Table 2](#), consists of a conversion result of N bits, where N is the width of the output data word. The output data word is provided on data lines (**SDO-xx**) for each ADC.

**表 2. Output Data Word**

DEVICE	RESOLUTION OF DEVICE (R)	WIDTH OF OUTPUT DATA WORD (N)	CONTENT OF OUTPUT DATA WORD <sup>(1)(2)</sup>	MSB OF CONVERSION RESULT WITH LEFT ALIGNMENT	MSB OF CONVERSION RESULT WITH RIGHT ALIGNMENT
ADS9224R	16	16	16-bit conversion in 2's compliment format	$D_{N-1}$ (= $D_{15}$ )	$D_{N-1}$ (= $D_{15}$ )
ADS9234R	14	16	14-bit conversion in 2's compliment format	$D_{N-1}$ (= $D_{13}$ )	$D_{N-3}$ (= $D_{13}$ )

(1) The device provides register data in the output data word during register read operation.

(2) When a fixed pattern data is enabled, the device provides a fixed pattern in the output data word.

For ADS9234R devices with 14-bit resolution, the output data word can be left-aligned or right-aligned by configuring the **DATA\_RIGHT\_ALIGNED** bit. With left alignment, the device appends zeros in the end of the output data word. With right alignment, the device appends MSBs in the beginning of the output data word. [Figure 46](#) shows the data alignment in the data output word.

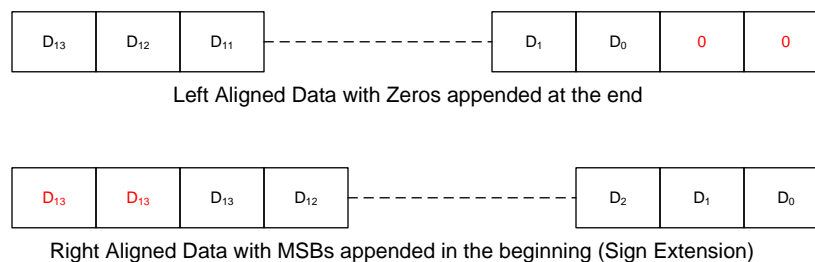

**图 46. Data Alignment for ADS9234R Devices**

## 7.6.2 Data Transfer Protocols

This device features an enhanced-SPI digital interface that allows the host controller to operate at slower SCLK speeds and still achieve the required throughput and response time. The enhanced-SPI digital interface module offers three options to reduce the SCLK speed required for data transfer:

- Increase the width of the output data bus (dual SDO, quad SDO, or parallel byte)
- Enable double data rate (DDR) transfer
- Wider read cycle by extending the data transfer window (zone 2 transfer)

These three options can be combined to achieve further reduction in SCLK speed.

### 7.6.2.1 Protocols for Reading From the Device

The protocols for the data-read operation can be broadly classified into five categories:

1. Legacy, SPI-compatible protocols (SPI-xy-S-SDR)
2. SPI-compatible protocols with bus width options and single data rate (SPI-xy-D-SDR and SPI-xy-Q-SDR)
3. SPI-compatible protocols with bus width options and double data rate (SPI-x1-S-DDR, SPI-x1-D-DDR, and SPI-x1-Q-DDR)
4. Clock re-timer (CRT) protocols (CRT-S-SDR, CRT-D-SDR, CRT-Q-SDR, CRT-S-DDR, CRT-D-DDR, and CRT-Q-DDR)
5. Parallel byte protocol (PB-xy-AB-SDR, PB-xy-AA-SDR)

#### 7.6.2.1.1 Legacy, SPI-Compatible Protocols (SPI-xy-S-SDR)

The device supports legacy, SPI-compatible protocols with all combinations of clock phase and polarity. In this data transfer protocol, the device provides data from ADC\_A on SDO-0A and data from ADC\_B on SDO-0B. On power-up or after reset, the device supports the SPI-00-S-SDR protocol for reading data from the device. [表 3](#) provides the details of different legacy SPI protocols to read data from the device.

**表 3. SPI-xy-S-SDR Protocols for Reading From Device**

PROTOCOL <sup>(1)</sup>	SCLK POLARITY (CPOL <sup>(2)</sup> )	SCLK PHASE (CPHA <sup>(2)(3)(4)</sup> )	MSB LAUNCH EDGE	BUS WIDTH	t <sub>READ</sub> <sup>(5)(6)</sup>	TIMING DIAGRAM
SPI-00-S-SDR	Low (CPOL= 0)	Rising (CPHA = 0)	$\overline{CS}$ falling	1	[15.5 × t <sub>CLK</sub> + k]	<a href="#">图 47</a>
SPI-01-S-SDR	Low (CPOL= 0)	Falling (CPHA = 1)	1 <sup>st</sup> SCLK rising	1	[15.5 × t <sub>CLK</sub> + k]	<a href="#">图 48</a>
SPI-10-S-SDR	High (CPOL= 1)	Falling (CPHA = 0)	$\overline{CS}$ falling	1	[15.5 × t <sub>CLK</sub> + k]	<a href="#">图 47</a>
SPI-11-S-SDR	High (CPOL= 1)	Rising (CPHA = 1)	1 <sup>st</sup> SCLK falling	1	[15.5 × t <sub>CLK</sub> + k]	<a href="#">图 48</a>

(1) For legacy SPI-compatible protocols, set the SDO\_PROTOCOL bits in [PROTOCOL\\_CFG register](#) to 000b.

(2) Configure the SPI\_CPOL and SPI\_CPHA bits in the [PROTOCOL\\_CFG register](#) for the desired CPOL and CPHA.

(3) With SCLK ≥ 30 MHz, TI recommends data capture on the launch edge for the next bit.

(4) With SCLK < 30 MHz, data can be captured either on the same edge as the SCLK phase or on the launch edge for the next bit.

(5) t<sub>READ</sub> is the read time for reading the 16-bit output data word. k = (t<sub>SU\_CSCK</sub> + t<sub>HT\_CKCS</sub>).

(6) For ADS9234R devices, the read time for reading the 14-bit output data word is [13.5 × t<sub>CLK</sub> + k].

图 47 和 图 48 show timing diagrams for the SPI-00-S-SDR, SPI-10-S-SDR and SPI-01-S-SDR, SPI-11-S-SDR protocols, respectively.

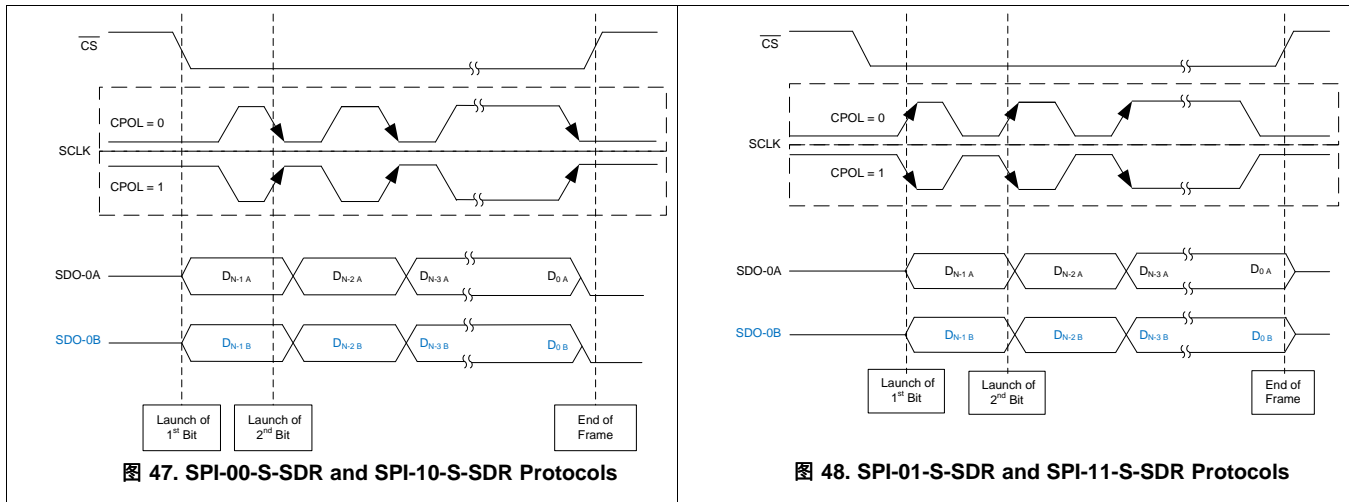

#### 7.6.2.1.2 SPI-Compatible Protocols With Bus Width Options and Single Data Rate (SPI-xy-D-SDR and SPI-xy-Q-SDR)

In this data transfer protocol, the bus width of reading data from each ADC can be increased to two SDOs or four SDOs. All combinations of clock phase and polarity are supported. The read time required for reading the output data word reduces with increases in bus width and, thus,  $t_{CYCLE}$  for zone 1 transfer reduces. The SDOs that are not enabled by the `BUS_WIDTH` register are set to tri-state. 表 4 provides the details of different SPI protocols with bus width options and single data rate to read data from the device.

表 4. SPI-xy-D-SDR and SPI-xy-Q-SDR Protocols for Reading From Device

PROTOCOL <sup>(1)</sup>	SCLK POLARITY (CPOL) <sup>(2)</sup>	SCLK PHASE (CPHA) <sup>(3)(4)</sup>	MSB LAUNCH EDGE	BUS WIDTH <sup>(5)</sup>	$t_{READ}$ <sup>(6)(7)</sup>	TIMING DIAGRAM
SPI-00-D-SDR	Low (CPOL = 0)	Rising (CPHA = 0)	$\overline{CS}$ falling	2	$[7.5 \times t_{CLK} + k]$	图 49
SPI-01-D-SDR	Low (CPOL = 0)	Falling (CPHA = 1)	1 <sup>st</sup> SCLK rising	2	$[7.5 \times t_{CLK} + k]$	图 50
SPI-10-D-SDR	High (CPOL = 1)	Falling (CPHA = 0)	$\overline{CS}$ falling	2	$[7.5 \times t_{CLK} + k]$	图 49
SPI-11-D-SDR	High (CPOL = 1)	Rising (CPHA = 1)	1 <sup>st</sup> SCLK falling	2	$[7.5 \times t_{CLK} + k]$	图 50
SPI-00-Q-SDR	Low (CPOL = 0)	Rising (CPHA = 0)	$\overline{CS}$ falling	4	$[3.5 \times t_{CLK} + k]$	图 51
SPI-01-D-SDR	Low (CPOL = 0)	Falling (CPHA = 1)	1 <sup>st</sup> SCLK rising	4	$[3.5 \times t_{CLK} + k]$	图 52
SPI-10-D-SDR	High (CPOL = 1)	Falling (CPHA = 0)	$\overline{CS}$ falling	4	$[3.5 \times t_{CLK} + k]$	图 51
SPI-11-D-SDR	High (CPOL = 1)	Rising (CPHA = 1)	1 <sup>st</sup> SCLK falling	4	$[3.5 \times t_{CLK} + k]$	图 52

- (1) For SPI-compatible protocols with bus width options and SDR, set the SDO\_PROTOCOL bits in the `PROTOCOL_CFG` register to 000b.
- (2) Configure the SPI\_CPOL and SPI\_CPHA bits in the `PROTOCOL_CFG` register for the desired CPOL and CPHA.
- (3) With SCLK  $\geq$  30 MHz, TI recommends data capture on the launch edge for the next bit.
- (4) With SCLK < 30 MHz, data can be captured either on the same edge as the SCLK phase or on the launch edge for the next bit.
- (5) For configuring the bus width, configure the `BUS_WIDTH` register.
- (6)  $t_{READ}$  is the read time for reading the 16-bit output data word.  $k = (t_{SU\_CSCK} + t_{HT\_CKCS})$ .
- (7) For ADS9234R devices, the read time for reading the 14-bit output data word is  $[6.5 \times t_{CLK} + k]$  for a bus width of 2 and  $[3.5 \times t_{CLK} + k]$  for a bus width of 4.



图 49, 图 50, 图 51, 和 图 52 show timing diagrams for the SPI-00-D-SDR and SPI-10-D-SDR, SPI-01-D-SDR and SPI-11-D-SDR, SPI-00-Q-SDR and SPI-10-Q-SDR, and SPI-01-Q-SDR and SPI-11-Q-SDR protocols, respectively.



图 49. SPI-00-D-SDR and SPI-10-D-SDR Protocols



图 50. SPI-01-D-SDR and SPI-11-D-SDR Protocols

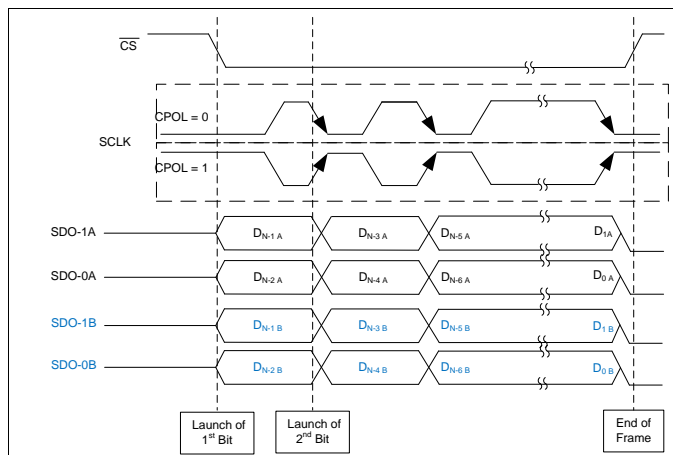

图 51. SPI-00-Q-SDR and SPI-10-Q-SDR Protocols

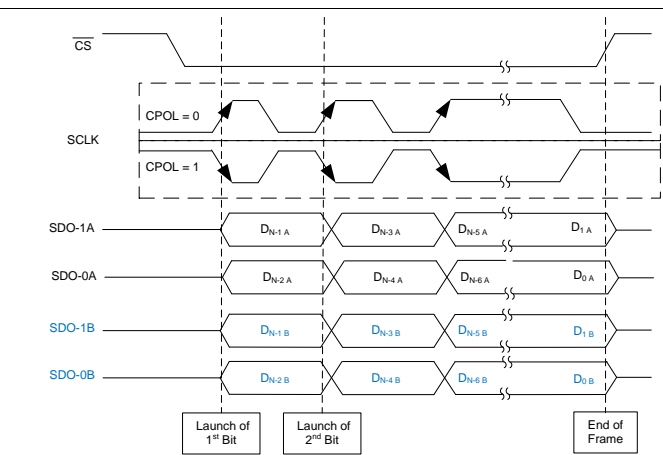

图 52. SPI-01-Q-SDR and SPI-11-Q-SDR Protocols

7.6.2.1.3 SPI-Compatible Protocols With Bus Width Options and Double Data Rate (SPI-x1-S-DDR, SPI-x1-D-DDR, SPI-x1-Q-DDR)

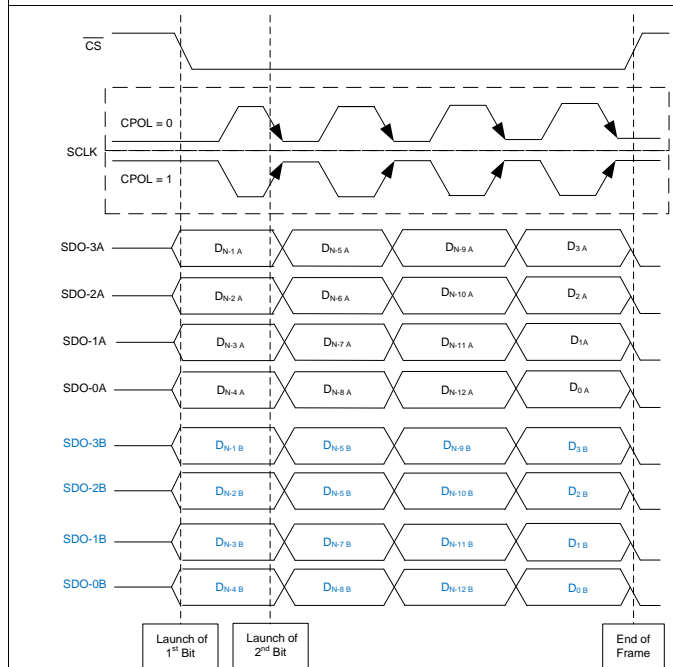
In this data transfer protocol, the data rate for data transfer can be increased to double data rate. With double data rate, the device launches data on both edges (rising and falling) of the SCLK. The device supports both polarities of the clock and only one phase of clock (CPHA = 1). The read time required for reading the output data word reduces with increases in bus width and data rate. The SDOs that are not enabled by the [BUS\\_WIDTH](#) register are set to tri-state. [表 5](#) provides the details of different SPI protocols with bus width options and double data rate to read data from the device.

表 5. SPI-x1-S-DDR, SPI-x1-D-DDR, and SPI-x1-Q-DDR Protocols for Reading From Device

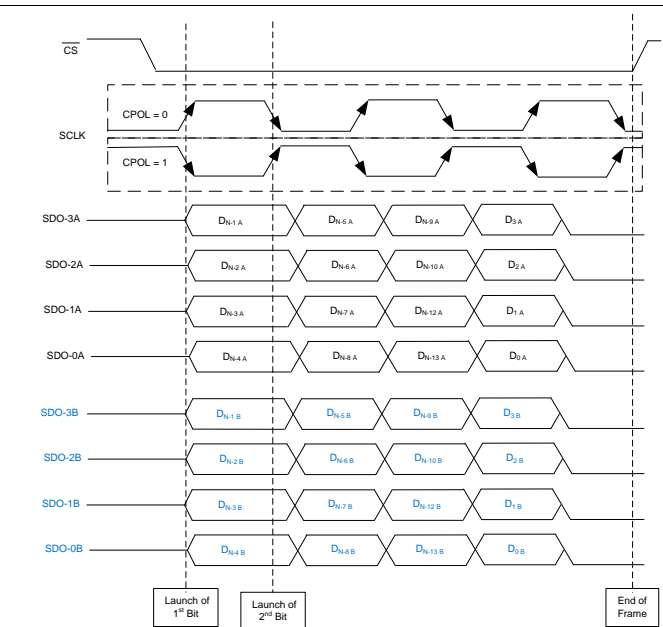
PROTOCOL <sup>(1)</sup>	SCLK POLARITY (CPOL) <sup>(2)</sup>	SCLK PHASE <sup>(2)</sup>	MSB LAUNCH EDGE	BUS WIDTH <sup>(3)</sup>	t <sub>READ</sub> <sup>(4)(5)</sup>	TIMING DIAGRAM
SPI-01-S-DDR	Low (CPOL = 0)	Falling (CPHA = 1)	1 <sup>st</sup> SCLK rising	1	[9 × t <sub>CLK</sub> + k]	<a href="#">图 53</a>
SPI-11-S-DDR	High (CPOL = 1)	Rising (CPHA = 1)	1 <sup>st</sup> SCLK falling	1	[9 × t <sub>CLK</sub> + k]	<a href="#">图 53</a>
SPI-01-D-DDR	Low (CPOL = 0)	Falling (CPHA = 1)	1 <sup>st</sup> SCLK rising	2	[5 × t <sub>CLK</sub> + k]	<a href="#">图 54</a>
SPI-11-D-DDR	High (CPOL = 1)	Rising (CPHA = 1)	1 <sup>st</sup> SCLK falling	2	[5 × t <sub>CLK</sub> + k]	<a href="#">图 54</a>
SPI-01-Q-DDR	Low (CPOL = 0)	Falling (CPHA = 1)	1 <sup>st</sup> SCLK rising	4	[3 × t <sub>CLK</sub> + k]	<a href="#">图 55</a>
SPI-11-Q-DDR	High (CPOL = 1)	Rising (CPHA = 1)	1 <sup>st</sup> SCLK falling	4	[3 × t <sub>CLK</sub> + k]	<a href="#">图 55</a>

- (1) For SPI-compatible protocols with bus width options and DDR, set the SDO\_PROTOCOL bits in the [PROTOCOL\\_CFG](#) register to 001b.
- (2) Configure the SPI\_CPOL bits in the [PROTOCOL\\_CFG](#) register for the desired CPOL. The device supports CPHA = 1 only for SPI-compatible protocols with bus width options and DDR.
- (3) For configuring the bus width, configure the [BUS\\_WIDTH](#) register.
- (4) t<sub>READ</sub> is the read time for reading the 16-bit output data word. k = (t<sub>SU\_CSCK</sub> + t<sub>HT\_CKCS</sub>).
- (5) For ADS9234R devices, the read time for reading the 14-bit output data word is [7.5 × t<sub>CLK</sub> + k] for a bus width of 1, [3.5 × t<sub>CLK</sub> + k] for a bus width of 2, and [3 × t<sub>CLK</sub> + k] for a bus width of 4.

[图 53](#), [图 54](#), and [图 55](#) illustrate timing diagrams for the SPI-01-S-DDR and SPI-11-S-DDR, SPI-01-D-DDR and SPI-11-D-DDR, and SPI-01-Q-DDR and SPI-11-Q-DDR protocols, respectively.

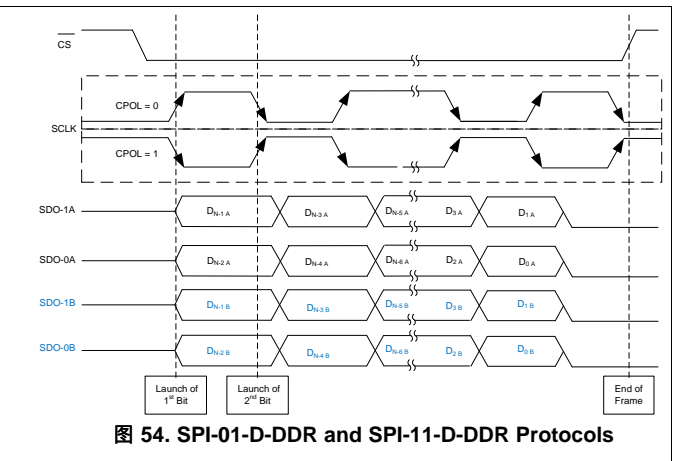
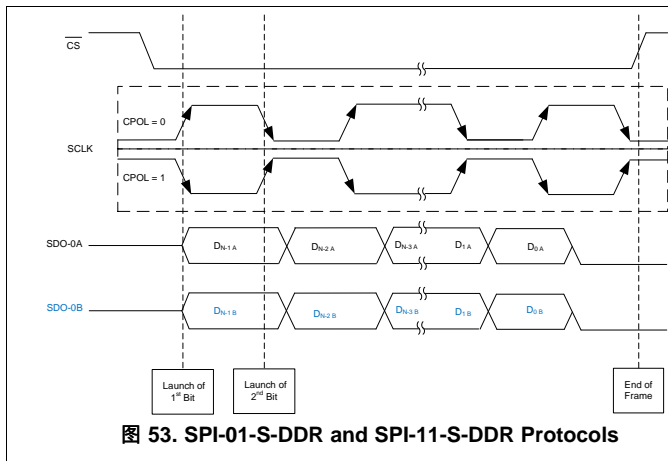



图 55. SPI-01-Q-DDR and SPI-11-Q-DDR Protocols

7.6.2.1.4 Clock Re-Timer (CRT) Protocols (CRT-S-SDR, CRT-D-SDR, CRT-Q-SDR, CRT-S-DDR, CRT-D-DDR, CRT-Q-DDR)

In clock re-timer (CRT) protocols, the device sends out data on the SDO lines with a synchronized clock on the STROBE line. The data are synchronized to the rising edges of the STROBE pulses. For CRT protocols with a single data rate, the host can capture data on the falling edges of the STROBE pulses. For double data rate, the host must capture data on both edges of STROBE. The clock source for the STROBE output can be selected as an external clock (SCLK) or an internal clock by configuring the CRT\_CLK\_SELECT bits in the [CRT\\_CFG register](#). For reading data from the device, SCLK is only required when the STROBE output is selected as an external clock. The SDOs that are not enabled by the [BUS\\_WIDTH register](#) are set to tri-state. [表 6](#) provides the details of different CRT protocols to read data from the device.

表 6. CRT-S-SDR, CRT-D-SDR, CRT-Q-SDR, CRT-S-DDR, CRT-D-DDR, and CRT-Q-DDR Protocols for Reading From Device

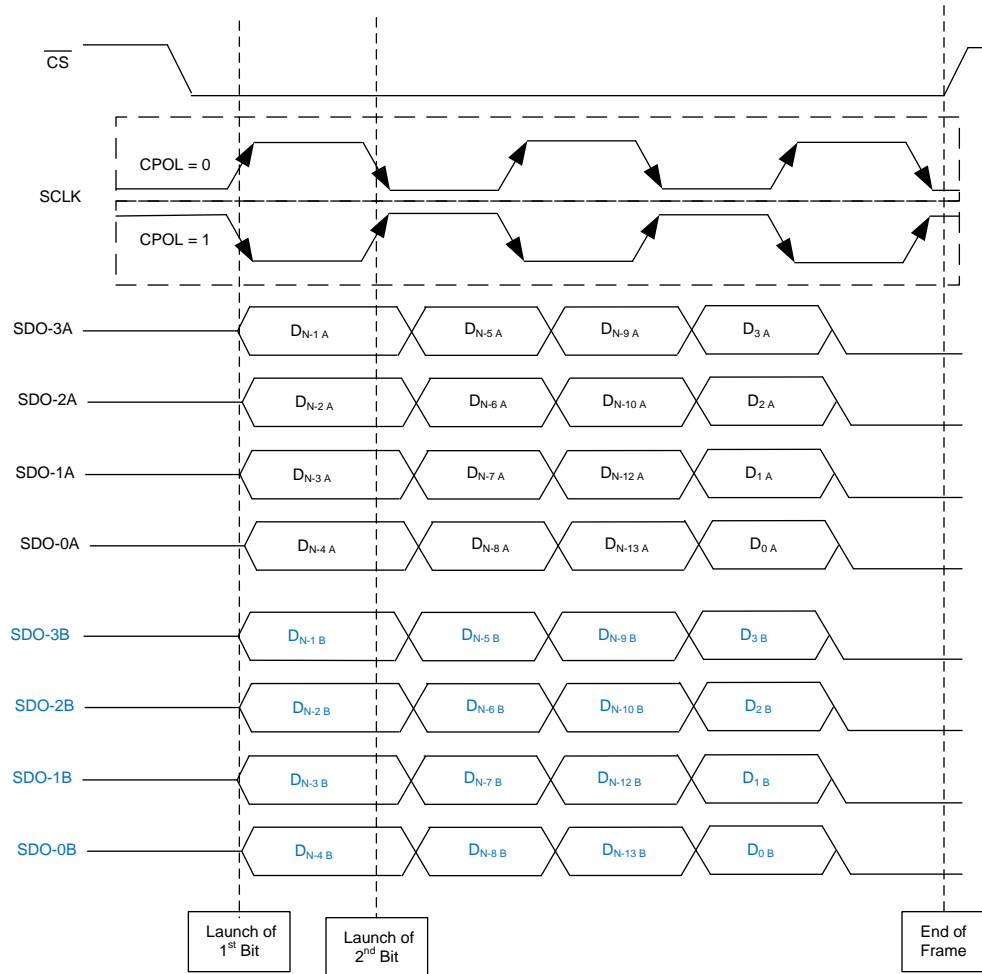
PROTOCOL <sup>(1)</sup>	SCLK POLARITY <sup>(2)</sup>	CAPTURE EDGE	MSB LAUNCH EDGE	BUS WIDTH <sup>(3)</sup>	t <sub>READ</sub> <sup>(4)</sup>	TIMING DIAGRAM
CRT-S-SDR	Low (CPOL = 0)	STROBE falling	1 <sup>st</sup> STROBE rising	1	[15.5 × t <sub>STROBE</sub> + m]	<a href="#">图 56</a>
CRT-D-SDR	Low (CPOL = 0)	STROBE falling	1 <sup>st</sup> STROBE rising	2	[7.5 × t <sub>STROBE</sub> + m]	<a href="#">图 58</a>
CRT-Q-SDR	Low (CPOL = 0)	STROBE falling	1 <sup>st</sup> STROBE rising	4	[3.5 × t <sub>STROBE</sub> + m]	<a href="#">图 60</a>
CRT-S-DDR	Low (CPOL = 0)	STROBE rising and falling	1 <sup>st</sup> STROBE rising	1	[7.5 × t <sub>STROBE</sub> + m]	<a href="#">图 57</a>
CRT-D-DDR	Low (CPOL = 0)	STROBE rising and falling	1 <sup>st</sup> STROBE rising	2	[3.5 × t <sub>STROBE</sub> + m]	<a href="#">图 59</a>
CRT-Q-DDR	Low (CPOL = 0)	STROBE rising and falling	1 <sup>st</sup> STROBE rising	4	[1.5 × t <sub>STROBE</sub> + m]	<a href="#">图 61</a>

- (1) For CRT protocols with SDR, set the SDO\_PROTOCOL bits in the [PROTOCOL\\_CFG register](#) to 010b. For CRT protocols with DDR, set the SDO\_PROTOCOL bits to 011b in the [PROTOCOL\\_CFG register](#).
- (2) The device only supports CPOL = 0 for CRT protocols with an external clock.
- (3) For configuring the bus width, configure the [BUS\\_WIDTH register](#).
- (4) t<sub>READ</sub> is the read time for reading the 16-bit output data word. For an external clock m = (t<sub>SU\_CSCK</sub> + t<sub>HT\_CKCS</sub>), and for an internal clock m = t<sub>D\_CS\_STROBE</sub>.

[图 56](#) through [图 61](#) illustrate timing diagrams for the CRT-S-SDR, CRT-S-DDR, CRT-D-SDR, CRT-D-DDR, CRT-Q-SDR, and CRT-Q-DDR protocols, respectively.

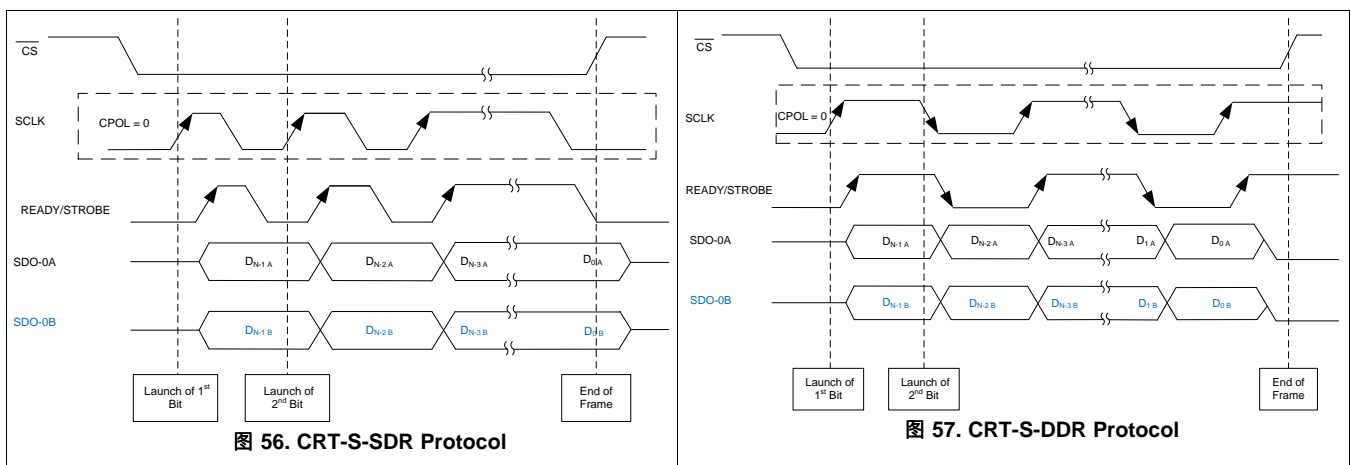



图 58. CRT-D-SDR Protocol



图 59. CRT-D-DDR Protocol

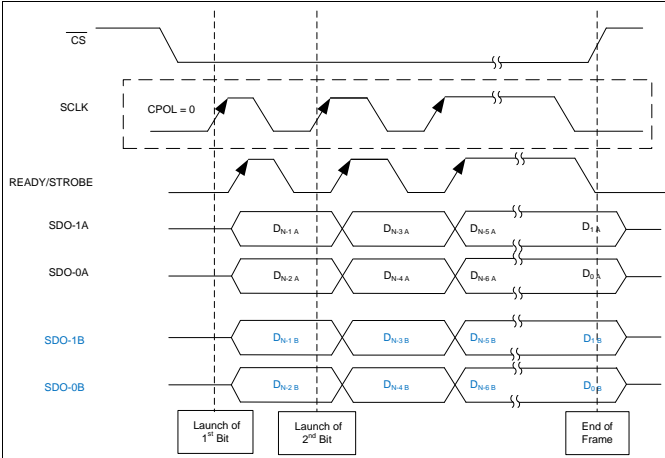

图 60. CRT-Q-SDR Protocol

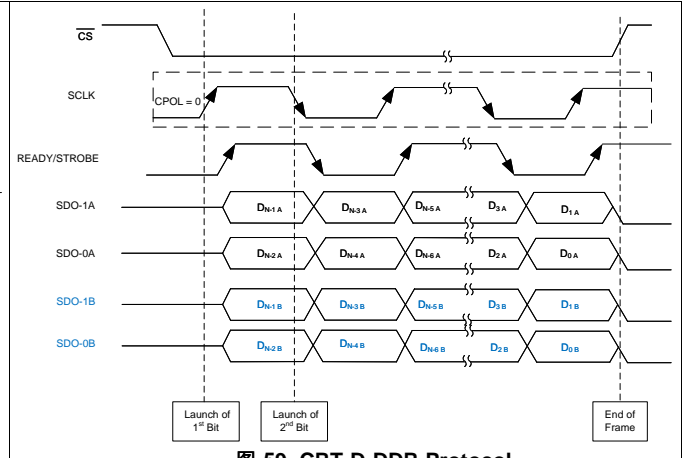

图 61. CRT-Q-DDR Protocol

For reading data, SCLK is only required when the STROBE output is selected as SCLK (external clock) in the `CRT_CFG` register. However, for configuring registers, SCLK is always required.

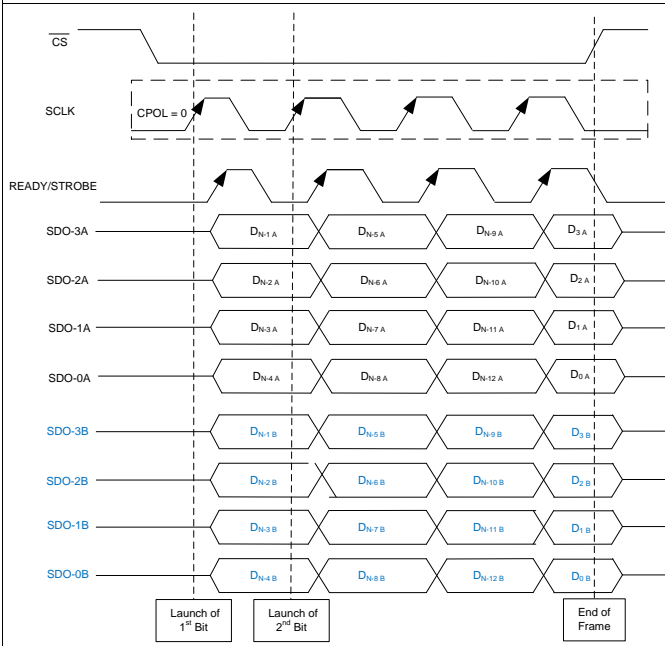
7.6.2.1.5 Parallel Byte Protocols (PB-xy-AB-SDR, PB-xy-AA-SDR)

In parallel byte protocols, the device sends out data from each ADC on all SDO lines in a byte format. The device supports all combinations of CPOL and CPHA in these protocols. The format of the data byte for these protocols can be set by the PARALLEL\_MODE\_DATA\_FORMAT bits in the OUTPUT\_DATA\_WORD\_CFG register. The device only supports a single data rate (SDR) in parallel byte protocols. 表 7 provides the details of different parallel byte protocols to read data from the device.

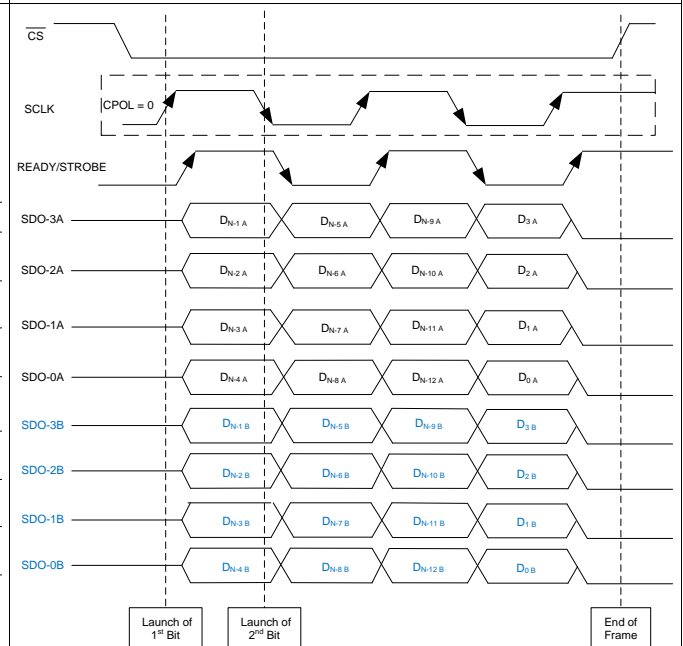
表 7. PB-xy-AB-SDR, PB-xy-AA-SDR Protocols for Reading Data

PROTOCOL <sup>(1)</sup>	SCLK POLARITY (CPOL) <sup>(2)</sup>	SCLK PHASE (CPHA)	MSB LAUNCH EDGE	DATA FORMAT <sup>(3)</sup>	t <sub>READ</sub> <sup>(4)</sup>	TIMING DIAGRAM
PB-00-AB-SDR	Low (CPOL = 0)	Rising (CPHA = 0)	$\overline{CS}$ falling	AB	$[3.5 \times t_{CLK} + k]$	图 62
PB-01-AB-SDR	Low (CPOL = 0)	Falling (CPHA = 1)	1 <sup>st</sup> SCLK rising	AB	$[3.5 \times t_{CLK} + k]$	图 63
PB-10-AB-SDR	High (CPOL = 1)	Falling (CPHA = 1)	$\overline{CS}$ falling	AB	$[3.5 \times t_{CLK} + k]$	图 62
PB-11-AB-SDR	High (CPOL = 1)	Rising (CPHA = 0)	1 <sup>st</sup> SCLK falling	AB	$[3.5 \times t_{CLK} + k]$	图 63
PB-00-AA-SDR	Low (CPOL = 0)	Rising (CPHA = 0)	$\overline{CS}$ falling	AA	$[3.5 \times t_{CLK} + k]$	图 64
PB-01-AA-SDR	Low (CPOL = 0)	Falling (CPHA = 1)	1 <sup>st</sup> SCLK rising	AA	$[3.5 \times t_{CLK} + k]$	图 65
PB-10-AA-SDR	High (CPOL = 1)	Falling (CPHA = 1)	$\overline{CS}$ falling	AA	$[3.5 \times t_{CLK} + k]$	图 64
PB-11-AA-SDR	High (CPOL = 1)	Rising (CPHA = 0)	1 <sup>st</sup> SCLK falling	AA	$[3.5 \times t_{CLK} + k]$	图 65

- (1) For parallel byte protocols, set the SDO\_PROTOCOL bits in the PROTOCOL\_CFG register to 1xxb.
- (2) Configure the SPI\_CPOL and SPI\_CPHA bits in the PROTOCOL\_CFG register for the desired CPOL and CPHA.
- (3) For selecting the data format for parallel byte protocols, configure the PARALLEL\_MODE\_DATA\_FORMAT bits in the OUTPUT\_DATA\_WORD\_CFG register.
- (4) t<sub>READ</sub> is the read time for reading the 16-bit output data word.  $k = (t_{SU\_CSCk} + t_{HT\_CKCS})$ .

图 62, 图 63, 图 64, and 图 65 illustrate timing diagrams for the PB-00-AB-SDR and PB-10-AB-SDR, protocols, PB-01-AB-SDR and PB-11-AB-SDR, PB-00-AA-SDR and PB-10-AA-SDR, and PB-01-AA-SDR and PB-11-AA-SDR, respectively.



图 62. PB-00-AB-SDR and PB-10-AB-SDR Protocols



图 63. PB-01-AB-SDR and PB-11-AB-SDR Protocols

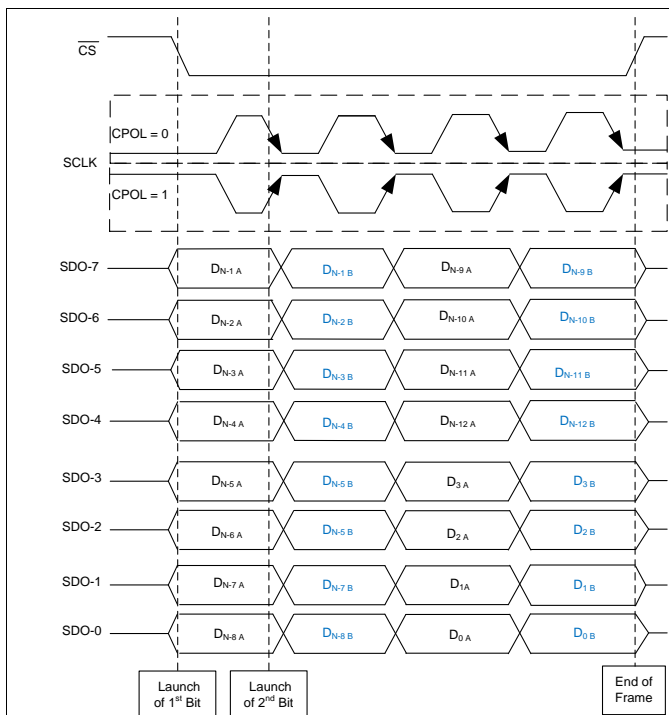

图 64. PB-00-AA-SDR and PB-10-AA-SDR Protocols

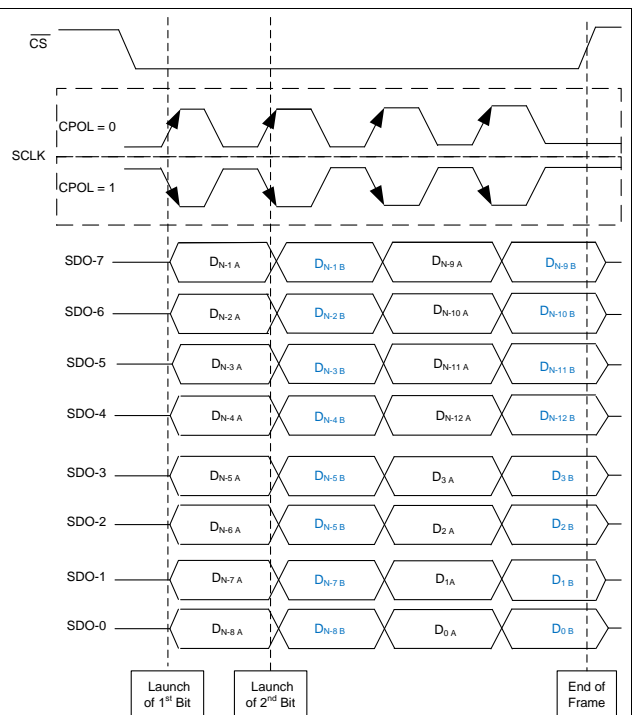

图 65. PB-01-AA-SDR and PB-11-AA-SDR Protocols

### 7.6.2.2 Device Setup

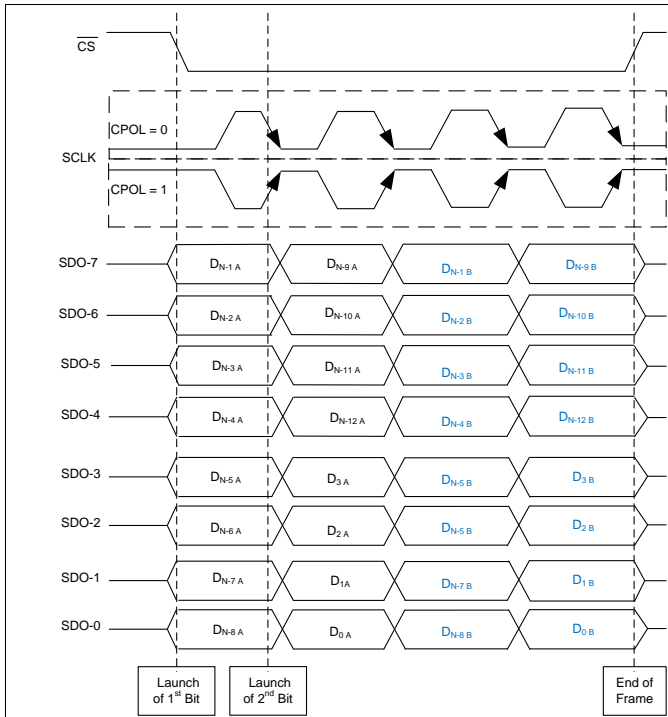
The enhanced-SPI digital interface and the device configuration registers offer multiple operation modes. This section describes how to select the hardware connection topology to meet different system requirements.

#### 7.6.2.2.1 Single Device: All Enhanced-SPI Options

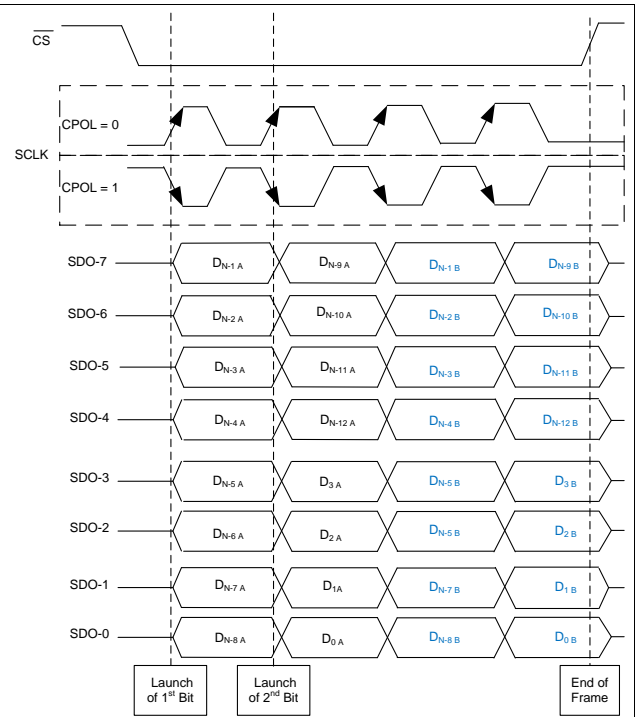
Figure 66 shows the connections between a host controller and a single device in order to exercise all options provided by the enhanced-SPI digital interface.



图 66. Enhanced-SPI Digital Interface, All Pins

#### 7.6.2.2.2 Single Device: Minimum Pins for a Standard SPI Interface

Figure 67 shows the minimum-pin interface for applications using a standard SPI protocol.

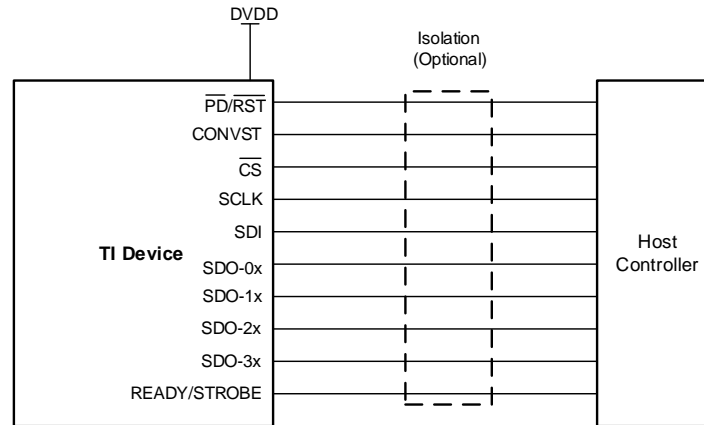

图 67. SPI Interface, Minimum Pins

The  $\overline{CS}$ , SCLK, SDI, and SDO-0x pins constitute a standard SPI port of the host controller. The CONVST pin is tied to  $\overline{CS}$ , and the  $\overline{PD/RST}$  pin is tied to DVDD. The SDO-1x, SDO-2x, and SDO-3x pins have no external connections. The following features are also available:

- Control the CONVST pin independently to get additional timing flexibility.
- Control  $\overline{PD/RST}$  pin independently to add asynchronous reset functionality.
- Monitor the READY/STROBE pin for additional timing benefits.

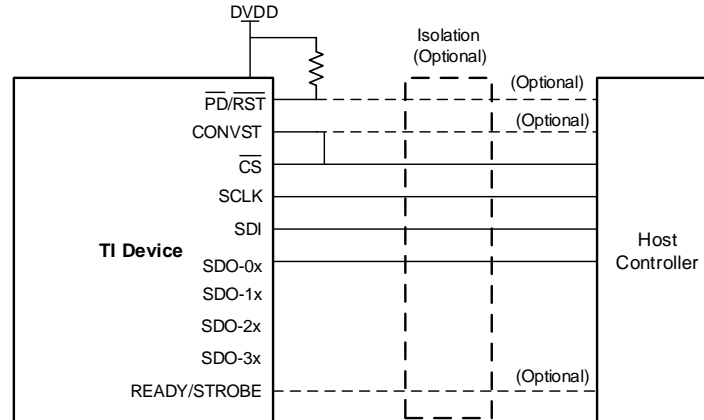

### 7.6.2.3 Protocols for Configuring the Device

The device supports an SPI protocol for writing into the device with all combinations of clock polarity and phase. On power-up or after reset, the device supports the SPI-00-S protocol for configuring the device. As shown in [表 8](#), the host controller can use any of the four legacy, SPI-compatible protocols (SPI-00-S, SPI-01-S, SPI-10-S, or SPI-11-S) to write data to the device.

**表 8. SPI Protocols for Configuring the Device**

PROTOCOL	SCLK POLARITY (CPOL) <sup>(1)</sup>	SCLK PHASE (CPHA) <sup>(1)</sup>	MSB CAPTURE EDGE	t <sub>WRITE</sub> <sup>(2)</sup>	TIMING DIAGRAM
SPI-00-S	Low (CPOL= 0)	Rising (CPHA = 0)	1 <sup>st</sup> SCLK rising	[15.5 × t <sub>CLK</sub> + k]	<a href="#">图 68</a>
SPI-01-S	Low (CPOL= 0)	Falling (CPHA = 1)	1 <sup>st</sup> SCLK falling	[15.5 × t <sub>CLK</sub> + k]	<a href="#">图 69</a>
SPI-10-S	High (CPOL= 1)	Falling (CPHA = 1)	1 <sup>st</sup> SCLK falling	[15.5 × t <sub>CLK</sub> + k]	<a href="#">图 68</a>
SPI-11-S	High (CPOL= 1)	Rising (CPHA = 0)	1 <sup>st</sup> SCLK rising	[15.5 × t <sub>CLK</sub> + k]	<a href="#">图 69</a>

(1) Configure the SPI\_CPOL and SPI\_CPHA bits in the [PROTOCOL\\_CFG register](#) for the desired CPOL and CPHA.

(2) t<sub>WRITE</sub> is the write time for writing the 16-bit data word. k = (t<sub>SU\_CSCK</sub> + t<sub>HT\_CKCS</sub>).

[图 68](#) 和 [图 69](#) show timing diagrams for the SPI-00-S, SPI-10-S and SPI-01-S, SPI-11-S protocols, respectively, for configuring the device.

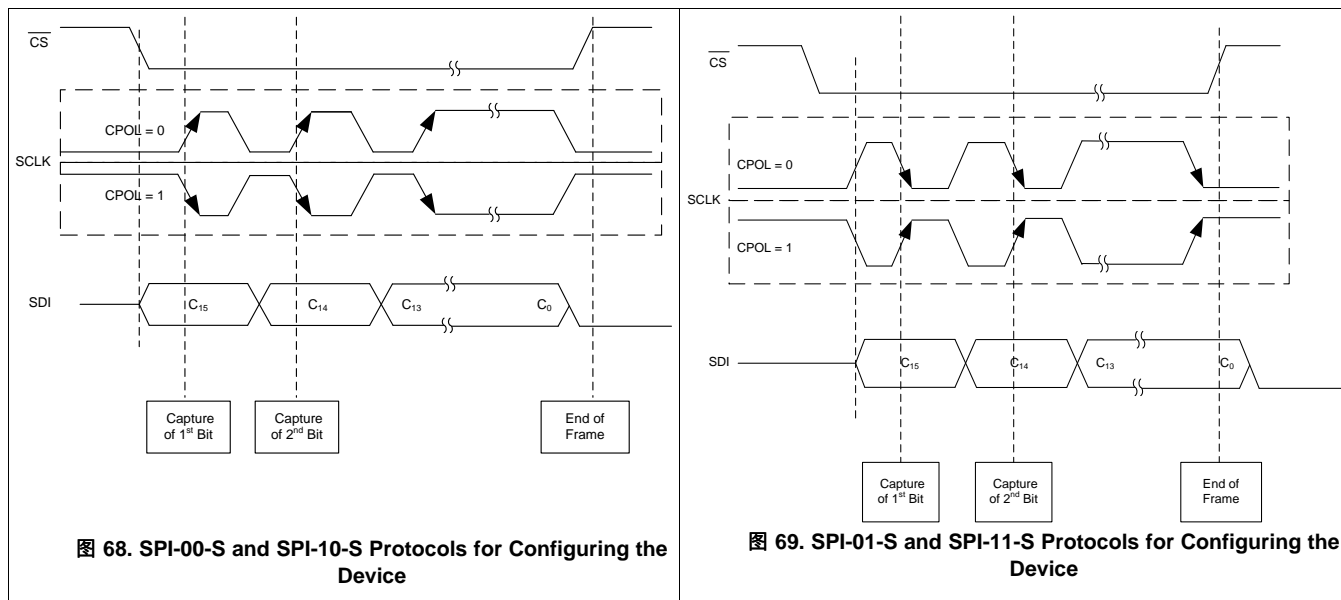

### 7.6.3 Reading and Writing Registers

To read a register or write into a register, the host must provide a 16-bit command frame C[15:0] on SDI. A command frame consists of an OPCODE[3:0], ADDRESS[3:0], and DATA[7:0]. The host must keep the CONVST signal high for reading and writing the registers. 图 70 shows the command frame. 表 9 provides the details of commands for reading and writing registers.



图 70. Command Frame C[15:0]

表 9. Commands for Reading and Writing Registers

OPCODE[3:0]		DESCRIPTION	ADDRESS[3:0]	DATA[7:0]
0000	NOP0	Command for conversion control and reading conversion results	N/A	N/A
0001	WRITE	Command for writing registers	4-bit register address	8-bit register data
0010	READ <sup>(1)</sup>	Command for reading registers	4-bit register address	00h or FFh
0101	Set bit	Command for setting specific bits in a register without changing the other bits	4-bit register address	Bits with values of 1 in DATA are set and bits with values of 0 in register data are not changed.
0110	Clear bit	Command for clearing specific bits in a register without changing the other bits	4-bit register address	Bits with values of 1 in DATA are cleared and bits with values of 0 in register data are not changed.
1111	NOP1	Command for conversion control and reading conversion results	N/A	N/A
Remain ing combin ations	xxxxxxxx	xxxxxxxx	Reserved	These commands are reserved and are treated by the device as no operation

(1) Register data for READ command is provided by device in the next frame.

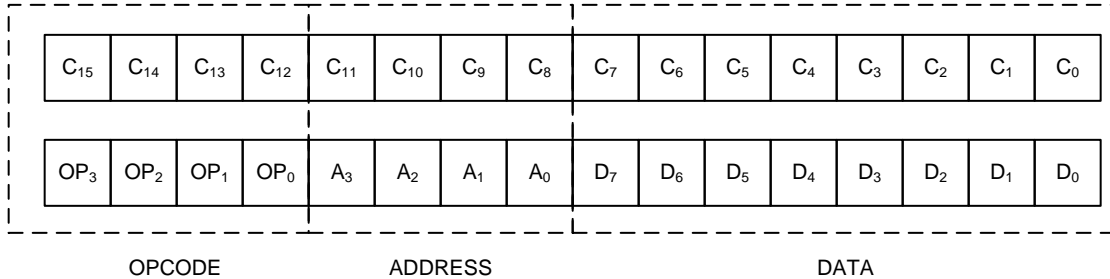
## 7.7 Register Maps

### 7.7.1 ADS92x4R Registers

Table 10 lists the ADS92x4R registers. All register offset addresses not listed in Table 10 should be considered as reserved locations and the register contents should not be modified.

**Table 10. ADS92X4R Registers**

Offset	Acronym	Register Name	Section
0h	DEVICE_STATUS	Device status register	DEVICE_STATUS Register (Offset = 0h) [reset = 0h]
1h	POWER_DOWN_CFG	Power down configuration register	POWER_DOWN_CFG Register (Offset = 1h) [reset = 0h]
2h	PROTOCOL_CFG	Protocol configuration register	PROTOCOL_CFG Register (Offset = 2h) [reset = 0h]
3h	BUS_WIDTH	Bus width configuration register	BUS_WIDTH Register (Offset = 3h) [reset = 0h]
4h	CRT_CFG	Clock re-timer configuration register	CRT_CFG Register (Offset = 4h) [reset = 0h]
5h	OUTPUT_DATA_WORD_CFG	Output data word configuration register	OUTPUT_DATA_WORD_CFG Register (Offset = 5h) [reset = 0h]
6h	DATA_AVG_CFG	Data averaging configuration register	DATA_AVG_CFG Register (Offset = 6h) [reset = 0h]
7h	REFBY2_OFFSET	REFby2 offset selection register	REFBY2_OFFSET Register (Offset = 7h) [reset = 0h]

Complex bit access types are encoded to fit into small table cells. Table 11 shows the codes that are used for access types in this section.

**Table 11. ADS92x4R Access Type Codes**

Access Type	Code	Description
<b>Read Type</b>		
R	R	Read
<b>Write Type</b>		
W	W	Write
<b>Reset or Default Value</b>		
-n		Value after reset or the default value
<b>Register Array Variables</b>		
i,j,k,l,m,n		When these variables are used in a register name, an offset, or an address, they refer to the value of a register array where the register is part of a group of repeating registers. The register groups form a hierarchical structure and the array is represented with a formula.
y		When this variable is used in a register name, an offset, or an address it refers to the value of a register array.

### 7.7.1.1 DEVICE\_STATUS Register (Offset = 0h) [reset = 0h]

DEVICE\_STATUS is shown in [Figure 71](#) and described in [Table 12](#).

Return to the [Summary Table](#).

Device status register

**Figure 71. DEVICE\_STATUS Register**

7	6	5	4	3	2	1	0
RESERVED					ZONE2_TRAN SFER	AVG_ERROR	RESERVED
R-00000b					R/W-0b	R/W-0b	R-0b

**Table 12. DEVICE\_STATUS Register Field Descriptions**

Bit	Field	Type	Reset	Description
7-3	RESERVED	R	00000b	Reserved bits. Do not write to these bits. Read returns 00000b
2	ZONE2_TRANSFER	R/W	0b	This bit is set when the device operates in zone 2 transfer mode with a wide read cycle. This bit is a sticky bit. Write 1 to this bit to clear.
1	AVG_ERROR	R/W	0b	This bit is set when the device receives a falling edge of CS before the current averaging operation is complete. This bit is a sticky bit. Write 1 to this bit to clear.
0	RESERVED	R	0b	Reserved bits. Do not write to this bit. Read returns 0b.

### 7.7.1.2 POWER\_DOWN\_CFG Register (Offset = 1h) [reset = 0h]

POWER\_DOWN\_CFG is shown in [Figure 72](#) and described in [Table 13](#).

Return to the [Summary Table](#).

Power down configuration register

**Figure 72. POWER\_DOWN\_CFG Register**

7	6	5	4	3	2	1	0
RESERVED		PD_REFBY2	RESERVED	PD_ADCB	RESERVED	PD_ADCA	PD_REF
R-00b		R/W-0b	R-0b	R/W-0b	R-0b	R/W-0b	R/W-0b

**Table 13. POWER\_DOWN\_CFG Register Field Descriptions**

Bit	Field	Type	Reset	Description
7-6	RESERVED	R	00b	Reserved bits. Do not write to these bits. Read returns 00b.
5	PD_REFBY2	R/W	0b	This bit powers down REFby2 output. 0b = _1 : REFby2 is not powered down. 1b = _2 : REFby2 is powered down.
4	RESERVED	R	0b	Reserved bits. Do not write to this bit. Read returns 0b.
3	PD_ADCB	R/W	0b	This bit powers down ADC_B and REFBUF_B. 0b = _1 : ADC_B and REFBUF_B are not powered down. 1b = _2 : ADC_B and REFBUF_B are powered down.
2	RESERVED	R	0b	
1	PD_ADCA	R/W	0b	This bit powers down ADC_A and REFBUF_A. 0b = _1 : ADC_A and REFBUF_A are not powered down. 1b = _2 : ADC_A and REFBUF_A are powered down.
0	PD_REF	R/W	0b	This bit powers down ADC's internal reference. 0b = _1 : ADC internal reference is not powered down. 1b = _2 : ADC internal reference is powered down.

### 7.7.1.3 PROTOCOL\_CFG Register (Offset = 2h) [reset = 0h]

PROTOCOL\_CFG is shown in Figure 73 and described in Table 14.

Return to the [Summary Table](#).

Protocol configuration register

Figure 73. PROTOCOL\_CFG Register

7	6	5	4	3	2	1	0
RESERVED	SDO_PROTOCOL[2:0]		RESERVED		SPI_CPOL	SPI_CPHA	
R-0b	R/W-000b		R-00b		R/W-0b	R/W-0b	

Table 14. PROTOCOL\_CFG Register Field Descriptions

Bit	Field	Type	Reset	Description
7	RESERVED	R	0b	Reserved bit. Do not write to this bit. Read returns 0b.
6-4	SDO_PROTOCOL[2:0]	R/W	000b	These bits set the protocol for reading data from the device. 000b = _1 : Legacy, SPI compatible protocols (SPI-xy-S-SDR); SPI compatible protocols with bus width options and SDR (SPI-xy-D-SDR and SPI-xy-Q-SDR) protocols. 001b = _2 : SPI compatible protocols with bus width options and DDR (SPI-x1-S-DDR, SPI-x1-D-DDR, SPI-x1-Q-DDR) protocols. 010b = _3 : Clock re-timer (CRT) protocols with SDR (CRT-S-SDR, CRT-D-SDR, CRT-Q-SDR). 011b = _4 : CRT protocols with DDR (CRT-S-DDR, CRT-D-DDR, CRT-Q-DDR). 100b = _5 : Parallel byte protocol. Writing 1xx enables parallel byte protocol. 101b = _6 : Parallel byte protocol. Writing 1xx enables parallel byte protocol. 110b = _7 : Parallel byte protocol. Writing 1xx enables parallel byte protocol. 111b = _8 : Parallel byte protocol. Writing 1xx enables parallel byte protocol.
3-2	RESERVED	R	00b	Reserved bits. Do not write to these bits. Read returns 00b.
1	SPI_CPOL	R/W	0b	This bit sets the clock polarity for reading data from the device and writing data into the device. 0b = _1 : CPOL = 0 1b = _2 : CPOL = 1
0	SPI_CPHA	R/W	0b	This bit sets the clock phase for reading data from the device and writing data into the device. 0b = _1 : CPHA = 0 1b = _2 : CPHA = 1

### 7.7.1.4 BUS\_WIDTH Register (Offset = 3h) [reset = 0h]

BUS\_WIDTH is shown in Figure 74 and described in Table 15.

Return to the [Summary Table](#).

Bus width configuration register

Figure 74. BUS\_WIDTH Register

7	6	5	4	3	2	1	0
RESERVED						SDO_WIDTH[1:0]	
R-000000b						R/W-00b	

**Table 15. BUS\_WIDTH Register Field Descriptions**

Bit	Field	Type	Reset	Description
7-2	RESERVED	R	000000b	Reserved bits. Do not write to these bits. Read returns 000000b.
1-0	SDO_WIDTH[1:0]	R/W	00b	These bits set the number of SDO lines for reading data from the device. If the device is configured for parallel byte protocol, then SDO_WIDTH is ignored and the device sends data over all eight SDO lines as per the parallel byte protocol. 00b = _1 : One SDO per ADC. 01b = _2 : One SDO per ADC. 10b = _3 : Dual SDO per ADC. 11b = _4 : Quad SDO per ADC.

**7.7.1.5 CRT\_CFG Register (Offset = 4h) [reset = 0h]**

CRT\_CFG is shown in [Figure 75](#) and described in [Table 16](#).

Return to the [Summary Table](#).

Clock re-timer configuration register

**Figure 75. CRT\_CFG Register**

7	6	5	4	3	2	1	0
RESERVED						CRT_CLK_SELECT[1:0]	
R-000000b						R/W-00b	

**Table 16. CRT\_CFG Register Field Descriptions**

Bit	Field	Type	Reset	Description
7-2	RESERVED	R	000000b	Reserved bits. Do not write to these bits. Read returns 000000b.
1-0	CRT_CLK_SELECT[1:0]	R/W	00b	These bits select the clock source for the strobe output for CRT protocols. 00b = _1 : Serial clock (SCLK) is used for STROBE output. 01b = _2 : INTCLK is used for the STROBE output. 10b = _3 : INTCLK/2 is used for the STROBE output. 11b = _4 : INTCLK/4 is used for the STROBE output.

**7.7.1.6 OUTPUT\_DATA\_WORD\_CFG Register (Offset = 5h) [reset = 0h]**

OUTPUT\_DATA\_WORD\_CFG is shown in [Figure 76](#) and described in [Table 17](#).

Return to the [Summary Table](#).

Output data word configuration register

**Figure 76. OUTPUT\_DATA\_WORD\_CFG Register**

7	6	5	4	3	2	1	0
RESERVED		READY_MASK	PARALLEL_M ODE_DATA_F ORMAT	RESERVED		FIXED_PATTE RN_DATA	DATA_RIGHT_ ALIGNED
R-00b		R/W-0b	R/W-0b	R-00b		R/W-0b	R/W-0b

**Table 17. OUTPUT\_DATA\_WORD\_CFG Register Field Descriptions**

Bit	Field	Type	Reset	Description
7-6	RESERVED	R	00b	Reserved bits. Do not write to these bits. Read returns 00b.
5	READY_MASK	R/W	0b	This bit masks the READY output. The STROBE output is provided in CRT protocols even if READY_MASK is set to 1. TI recommends masking the READY output for the Conversion Control and Data Transfer Frame With Wide Read Cycle (Zone 2 Transfer) section. 0b = _1 : Does not mask the READY output. 1b = _2 : Masks the READY output.
4	PARALLEL_MODE_DATA_FORMAT	R/W	0b	This bit selects the format for the output data word in the parallel byte protocol. 0b = _1 : Data format AA: byte from ADC_A followed by byte from ADC_A (PB-xy-AA-zDR protocol). 1b = _2 : Data format AB: byte from ADC_A followed by byte from ADC_B (PB-xy-AB-zDR protocol).
3-2	RESERVED	R	00b	Reserved bits. Do not write to these bits. Read returns 00b.
1	FIXED_PATTERN_DATA	R/W	0b	This bit enables a fixed pattern in the output data word. 0b = _1 : Device provides the conversion results from the register data in the output word. 1b = _2 : Device provides a fixed pattern (A55AA55Ah) in the output data word.
0	DATA_RIGHT_ALIGNED	R/W	0b	This bit enables the right alignment in the output data word for ADS9234R device. 0b = _1 : Data are left-aligned in the output data word. 1b = _2 : Data are right-aligned in the output data word.

**7.7.1.7 DATA\_AVG\_CFG Register (Offset = 6h) [reset = 0h]**

DATA\_AVG\_CFG is shown in [Figure 77](#) and described in [Table 18](#).

Return to the [Summary Table](#).

Data averaging configuration register

**Figure 77. DATA\_AVG\_CFG Register**

7	6	5	4	3	2	1	0
RESERVED						EN_DATA_AVG[1:0]	
R-000000b						R/W-00b	

**Table 18. DATA\_AVG\_CFG Register Field Descriptions**

Bit	Field	Type	Reset	Description
7-2	RESERVED	R	000000b	Reserved bits. Do not write to these bits. Read returns 000000b.
1-0	EN_DATA_AVG[1:0]	R/W	00b	These bits enable averaging of conversion results. 00b = _1 : No averaging. 01b = _2 : No averaging. 10b = _3 : Enables averaging of two conversion results. 11b = _4 : Enables averaging of four conversion results.

**7.7.1.8 REFBY2\_OFFSET Register (Offset = 7h) [reset = 0h]**

REFBY2\_OFFSET is shown in [Figure 78](#) and described in [Table 19](#).

Return to the [Summary Table](#).

REFby2 offset selection register

**Figure 78. REFBY2\_OFFSET Register**

7	6	5	4	3	2	1	0
RESERVED							EN_REFBY2_OFFSET
R-0000000b							R/W-0b

**Table 19. REFBY2\_OFFSET Register Field Descriptions**

Bit	Field	Type	Reset	Description
7-1	RESERVED	R	0000000b	Reserved bits. Do not write to these bits. Read returns 0000000b.
0	EN_REFBY2_OFFSET	R/W	0b	This bit enables the offset for the REFby2 output. 0b = <u>_1</u> : Offset for the REFby2 output is disabled. 1b = <u>_2</u> : Offset for the REFby2 output is enabled and the REFby2 output increases by 100 mV.



## 8 Application and Implementation

### 注

Information in the following applications sections is not part of the TI component specification, and TI does not warrant its accuracy or completeness. TI's customers are responsible for determining suitability of components for their purposes. Customers should validate and test their design implementation to confirm system functionality.

### 8.1 Application Information

This section presents general principles for designing these circuits, followed by an application circuit designed using the ADS92x4R.

#### 8.1.1 ADC Input Driver

The input driver circuit for a high-precision ADC mainly consists of two parts: a driving amplifier and a charge kickback filter. The amplifier is used for signal conditioning of the input signal and the low output impedance of the amplifier provides a buffer between the signal source and the switched-capacitor inputs of the ADC. The charge kickback filter helps attenuate the sampling charge injection from the switched-capacitor input stage of the ADC, and band-limits the wideband noise contributed by the front-end circuit. Careful design of the front-end circuit is critical to meet the linearity and noise performance of the ADS92x4R.

##### 8.1.1.1 Charge-Kickback Filter

The charge-kickback filter is an RC filter at the input pins of the ADC that filters the broadband noise from the front-end drive circuitry, and attenuates the sampling charge injection from the switched-capacitor input stage of the ADC. A filter capacitor,  $C_{FLT}$  (as shown in 图 79), is connected from each input pin of the ADC to the ground. This capacitor helps reduce the sampling charge injection and provides a charge bucket to quickly charge the internal sample-and-hold capacitors during the acquisition process. Generally, the value of this capacitor must be at least 20 times the specified value of the ADC sampling capacitance. For the ADS92x4R, the input sampling capacitance is equal to 16 pF; therefore, for optimal performance, keep  $C_{FLT}$  greater than 320 pF. This capacitor must be a C0G- or NP0-type. The type of dielectric used in C0G or NP0 ceramic capacitors provides the most stable electrical properties over voltage, frequency, and temperature changes.



图 79. Charge Kickback Filter

Driving capacitive loads can degrade the phase margin of the input amplifier, thus making the amplifier marginally unstable. To avoid amplifier stability issues, series isolation resistors ( $R_{FLT}$ ) are used at the output of the amplifiers. A higher value of  $R_{FLT}$  helps with amplifier stability, but adds distortion as a result of interactions with the nonlinear input impedance of the ADC. Distortion increases with source impedance, input signal frequency, and input signal amplitude. Therefore, the selection of  $R_{FLT}$  requires balancing the stability of the driver amplifier and distortion performance of the design. Always verify the stability and settling behavior of the driving amplifier and charge-kickback filter by TINA-TI™ SPICE simulation. Keep the tolerance of the selected resistors less than 1% to keep the inputs balanced.

## Application Information (接下页)

### 8.1.2 Input Amplifier Selection

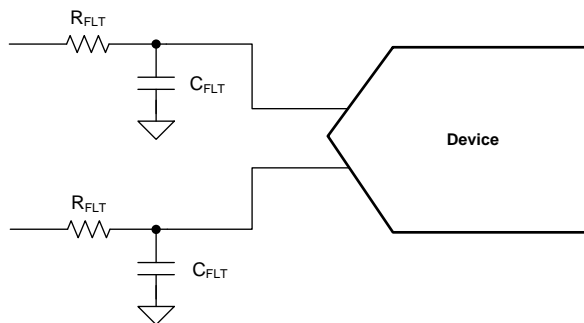
Selection criteria for the input amplifiers is highly dependent on the input signal type as well as the performance goals of the data acquisition system. Some key amplifier specifications to consider when selecting an appropriate amplifier to drive the inputs of the ADC are:

- Small-signal bandwidth. Select the small-signal bandwidth of the input amplifiers to be as high as possible after meeting the power budget of the system. Higher bandwidth reduces the closed-loop output impedance of the amplifier, thus allowing the amplifier to more easily drive the ADC sample-and-hold capacitor and the RC filter (the charge-kickback filter) at the inputs of the ADC. Higher bandwidth amplifiers offer faster settling times when driving the capacitive load of the charge-kickback filter, thus reducing harmonic distortion at higher input frequencies. 公式 4 describes the unity gain bandwidth (UGB) of the amplifier to be selected in order to maintain the overall stability of the input driver circuit:

$$UGB \geq 4 \times \left( \frac{1}{2\pi \times R_{FLT} \times C_{FLT}} \right) \quad (4)$$

- Distortion. Both the ADC and the input driver introduce distortion in a data acquisition block. 公式 5 shows that to make sure that the distortion performance of the data acquisition system is not limited by the front-end circuit, the distortion of the input driver must be at least 10 dB less than the distortion of the ADC:

$$THD_{AMP} \leq THD_{ADC} - 10 \text{ (dB)} \quad (5)$$

- Noise. Noise contribution of the front-end amplifiers must be as low as possible to prevent any degradation in SNR performance of the system. Generally, to make sure that the noise performance of the data acquisition system is not limited by the front-end circuit, the total noise contribution from the front-end circuit must be kept below 20% of the input-referred noise of the ADC. 公式 6 explains that noise from the input driver circuit is band-limited by designing a low cutoff frequency, charge-kickback filter:

$$N_G \times \sqrt{2} \times \sqrt{\left( \frac{V_{1/f\_AMP\_PP}}{6.6} \right)^2} + e_{n\_RMS}^2 \times \frac{\pi}{2} \times f_{-3dB} \leq \frac{1}{5} \times \frac{V_{REF}}{\sqrt{2}} \times 10^{-\left( \frac{SNR(dB)}{20} \right)}$$

where

- $V_{1/f\_AMP\_PP}$  is the peak-to-peak flicker noise in  $\mu V$
  - $e_{n\_RMS}$  is the amplifier broadband noise density in  $nV/\sqrt{Hz}$
  - $f_{-3dB}$  is the 3-dB bandwidth of the charge-kickback filter
  - $N_G$  is the noise gain of the front-end circuit that is equal to 1 in a buffer configuration
- (6)
- Settling Time. For DC signals with fast transients that are common in a multiplexed application, the input signal must settle within an 16-bit accuracy at the device inputs during the acquisition time window. This condition is critical to maintain the overall linearity performance of the ADC. Typically, amplifier data sheets specify the output settling performance only up to 0.1% to 0.001%, which may not be sufficient for the desired 16-bit accuracy. Therefore, always verify the settling behavior of the input driver by TINA-TI SPICE simulations before selecting the amplifier.

For additional details on SAR ADC input architecture and SAR ADC driver amplifier design, see the [TI Precision Labs for ADCs](#).



to the ADC. Generally, the distortion from the input driver must be at least 10 dB less than the ADC distortion. Therefore, these circuits use the low-power THS4551 as an input driver that provides exceptional AC performance because of its extremely low-distortion and high bandwidth specifications. In addition, the components of the charge kickback filter are selected to keep the noise from the front-end circuit low without adding distortion. This front-end circuit configuration requires a differential signal at the input of the FDA and provides a differential output to drive the ADC inputs. The FDA establishes a fixed common-mode voltage at the ADC inputs using the VOCM input pin from the FDA. The ADS92x4R incorporates a REFby2 buffer output for setting the common-mode voltage. The ADS92x4R REFby2 output is decoupled using a 1- $\mu$ F capacitor and connected to each FDA VOCM input pin. Each VOCM pin is decoupled using a 0.1- $\mu$ F capacitor. For a complete schematic, see the [ADS9224REVM-PDK user's guide](#) located in the [ADS9224R SAR analog to digital converter evaluation module tool folder](#).

### 8.2.3 Application Curves

图 81 provides the typical FFT for the circuit in 图 80 and 图 82 provides the typical INL for the circuit in 图 80.

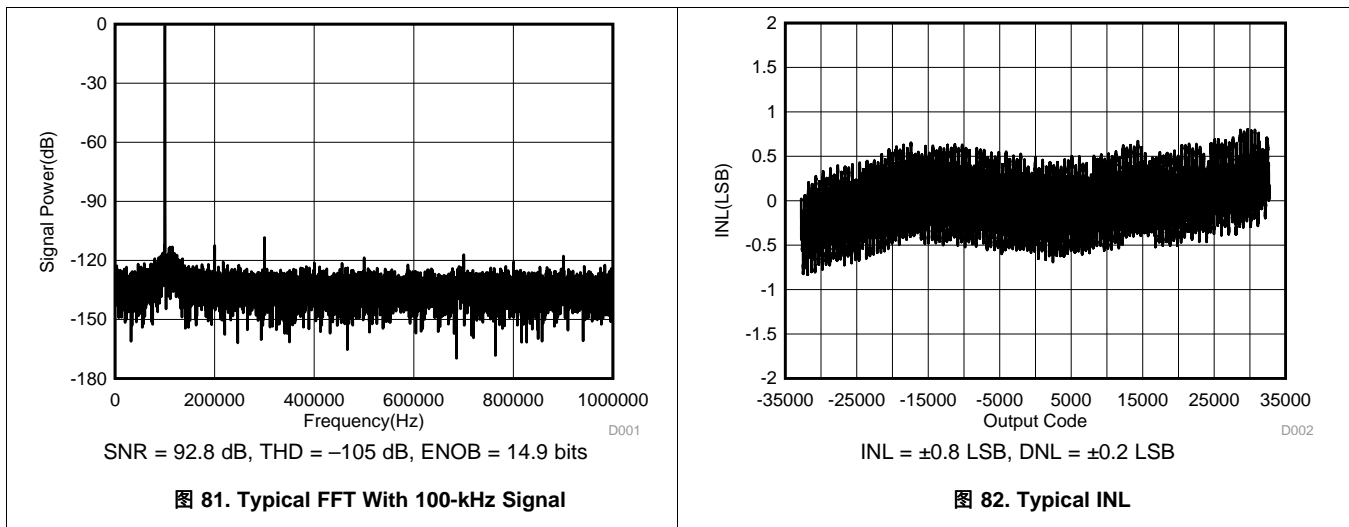

## 9 Power Supply Recommendations

The devices have two separate power supplies: AVDD and DVDD. The reference buffers, internal reference voltage, and converter modules (ADC\_A and ADC\_B) operate on AVDD. The serial interface operates on DVDD. AVDD and DVDD can be independently set to any value within their permissible ranges.

To operate the device with SCLK more than 20-MHz, TI recommends to set the DVDD voltage as:  $2.35\text{ V} \leq \text{DVDD} \leq 5.5\text{ V}$ .

As shown in [Figure 83](#), connect pins 12 and 29 together and place 1- $\mu\text{F}$  decoupling capacitors between pin 12 (AVDD) and pin 11 (GND), and between pin 29 (AVDD) and pin 30 (GND). To decouple the DVDD supply, place a 1- $\mu\text{F}$  decoupling capacitor between pin 28 (DVDD) and pin 27 (GND).



图 83. Power-Supply Decoupling

## 10 Layout

### 10.1 Layout Guidelines

This section provides some layout guidelines for achieving optimum performance with the ADS92x4R.

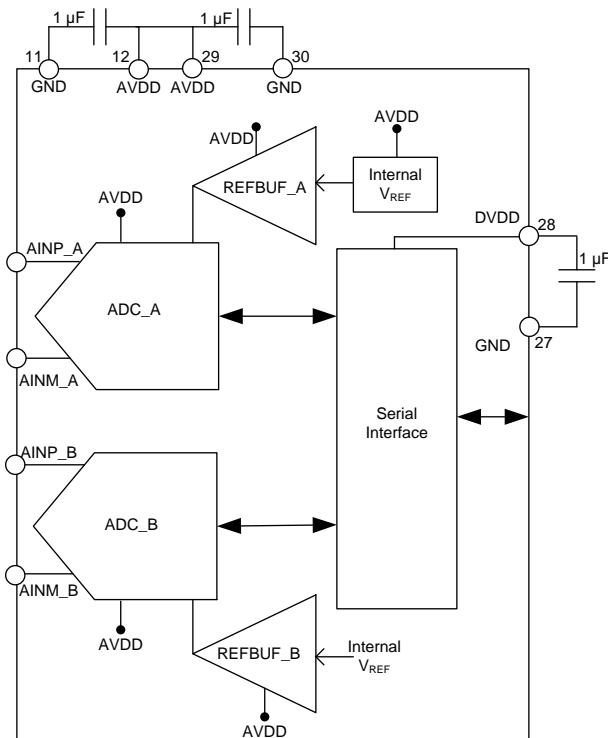
#### 10.1.1 Signal Path

As illustrated in [Figure 84](#), the analog input signals are routed in opposite directions to the digital connections. The reference decoupling components are kept away from the switching digital signals. This arrangement prevents noise generated by digital switching activity from coupling to sensitive analog signals.

#### 10.1.2 Grounding and PCB Stack-Up

Low inductance grounding is critical for achieving optimum performance. Grounding inductance is kept below 1 nH with 15-mil grounding vias and a printed circuit board (PCB) layout design that has at least four layers. Place all critical components of the signal chain on the top layer with a solid analog ground from subsequent inner layers to minimize via length to ground.

#### 10.1.3 Decoupling of Power Supplies

Place the decoupling capacitors on AVDD and DVDD within 20 mil from the respective pins, and use a 15-mil via to ground from each capacitor. Avoid placing vias between any supply pin and the respective decoupling capacitor.

#### 10.1.4 Reference Decoupling

Dynamic currents are present at the REFP\_x and REFM\_x pins during the conversion phase, and excellent decoupling is required to achieve optimum performance. Place a 10- $\mu$ F, X7R-grade, ceramic capacitor with at least a 10-V rating, as illustrated in [Figure 84](#). Select 0603- or 0805-size capacitors to keep equivalent series inductance (ESL) low. Connect the REFM\_x pins to the decoupling capacitor before a ground via. Also place decoupling capacitors on the REFOUT and REFby2 pins.

#### 10.1.5 Differential Input Decoupling

Dynamic currents are also present at the differential analog inputs of the ADS92x4R. Use C0G- or NPO-type capacitors to decouple these inputs because with these type of capacitors, capacitance stays almost constant over the full input voltage range. Lower-quality capacitors (such as X5R and X7R) have large capacitance changes over the full input-voltage range that may cause degradation in the performance of the device.

## 10.2 Layout Example

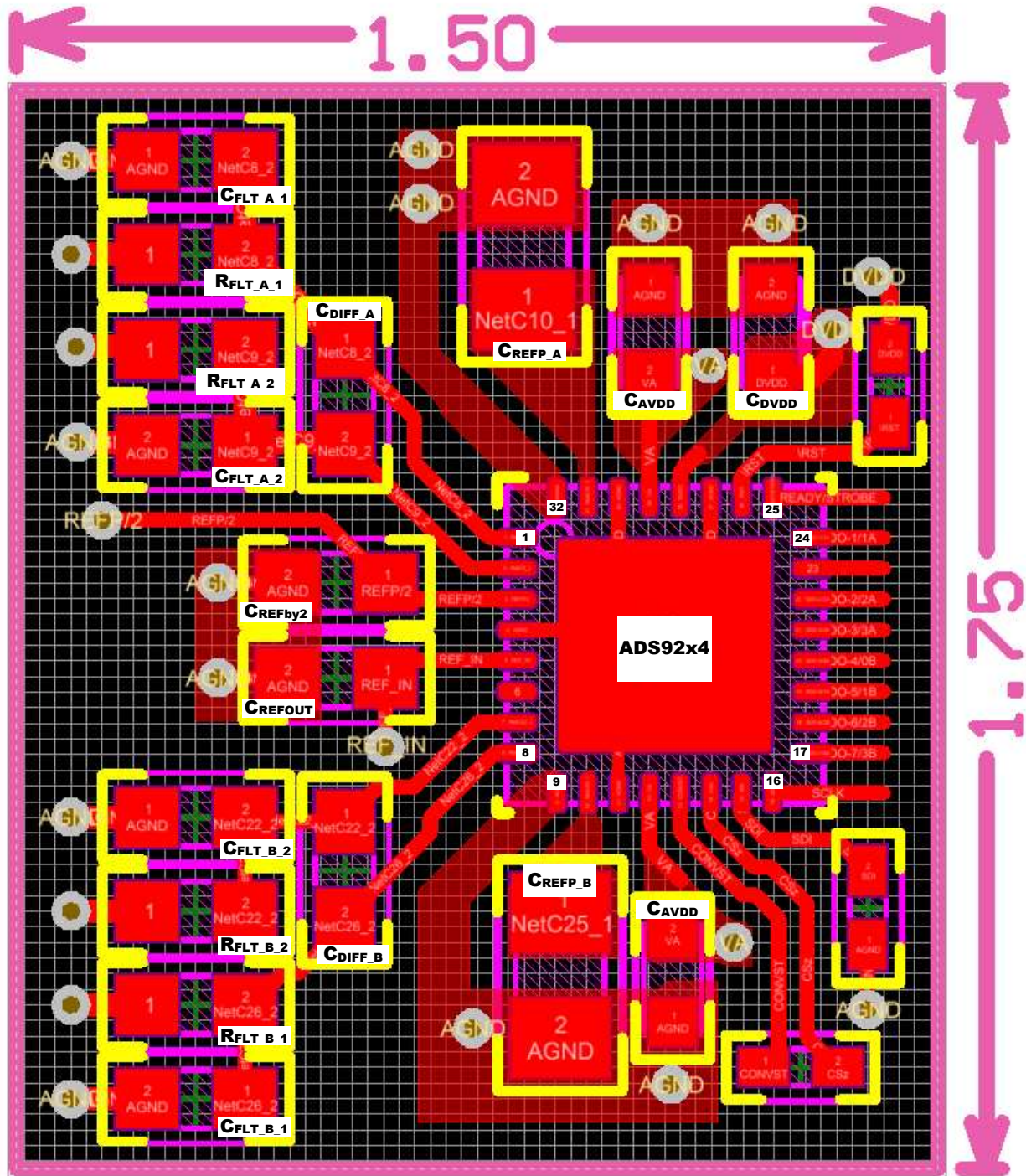

NOTE: Dimensions are in cm.

图 84. Example Layout for the ADS92x4R

## 11 器件和文档支持

### 11.1 器件支持

#### 11.1.1 开发支持

[TI 高精度 ADC 实验室](#)

### 11.2 相关文档

请参阅如下相关文档：

- 德州仪器 (TI), 《[THS4551 低噪声、高精度的 150MHz 全差分放大器](#)》数据表
- 德州仪器 (TI), 《[在电机控制应用中用于光学编码器的 12 位 1MSPS 单电源双通道数据采集系统](#)》参考指南
- 德州仪器 (TI), 《[REF50xx 低噪声、极低漂移、精密电压基准](#)》数据表
- 德州仪器 (TI), 《[OPAx350 高速单电源轨至轨运算放大器 MicroAmplifier 系列](#)》数据表
- 德州仪器 (TI), 《[THS452x 极低功耗、负轨输入、轨至轨输出、全差分放大器](#)》数据表
- 德州仪器 (TI), 《[ADS9224REVM-PDK 用户指南](#)》

### 11.3 相关链接

下表列出了快速访问链接。类别包括技术文档、支持和社区资源、工具和软件，以及立即订购快速访问。

表 21. 相关链接

器件	产品文件夹	立即订购	技术文档	工具与软件	支持和社区
ADS9224R	<a href="#">单击此处</a>	<a href="#">单击此处</a>	<a href="#">单击此处</a>	<a href="#">单击此处</a>	<a href="#">单击此处</a>
ADS9234R	<a href="#">单击此处</a>	<a href="#">单击此处</a>	<a href="#">单击此处</a>	<a href="#">单击此处</a>	<a href="#">单击此处</a>

### 11.4 接收文档更新通知

要接收文档更新通知，请导航至 [TI.com.cn](#) 上的器件产品文件夹。单击右上角的 [通知我](#) 进行注册，即可每周接收产品信息更改摘要。有关更改的详细信息，请查看任何已修订文档中包含的修订历史记录。

### 11.5 社区资源

The following links connect to TI community resources. Linked contents are provided "AS IS" by the respective contributors. They do not constitute TI specifications and do not necessarily reflect TI's views; see TI's [Terms of Use](#).

**TI E2E™ Online Community** *TI's Engineer-to-Engineer (E2E) Community*. Created to foster collaboration among engineers. At [e2e.ti.com](#), you can ask questions, share knowledge, explore ideas and help solve problems with fellow engineers.

**Design Support** *TI's Design Support* Quickly find helpful E2E forums along with design support tools and contact information for technical support.

### 11.6 商标

TINA-TI, E2E are trademarks of Texas Instruments.  
All other trademarks are the property of their respective owners.

### 11.7 静电放电警告



ESD 可能会损坏该集成电路。德州仪器 (TI) 建议通过适当的预防措施处理所有集成电路。如果不遵守正确的处理措施和安装程序，可能会损坏集成电路。

ESD 的损坏小至导致微小的性能降级，大至整个器件故障。精密的集成电路可能更容易受到损坏，这是因为非常细微的参数更改都可能会导致器件与其发布的规格不相符。

### 11.8 Glossary

[SLYZ022](#) — *TI Glossary*.

This glossary lists and explains terms, acronyms, and definitions.



## 12 机械、封装和可订购信息

以下页面包含机械、封装和可订购信息。这些信息是指定器件的最新可用数据。数据如有变更，恕不另行通知，且不会对此文档进行修订。如需获取此数据表的浏览器版本，请查阅左侧的导航栏。

**PACKAGING INFORMATION**

Orderable Device	Status (1)	Package Type	Package Drawing	Pins	Package Qty	Eco Plan (2)	Lead finish/ Ball material (6)	MSL Peak Temp (3)	Op Temp (°C)	Device Marking (4/5)	Samples
ADS9224RIRHBR	ACTIVE	VQFN	RHB	32	3000	RoHS & Green	NIPDAUAG	Level-2-260C-1 YEAR	-40 to 125	ADS9224	<a href="#">Samples</a>
ADS9224RIRHBT	ACTIVE	VQFN	RHB	32	250	RoHS & Green	NIPDAUAG	Level-2-260C-1 YEAR	-40 to 125	ADS9224	<a href="#">Samples</a>
ADS9234RIRHBR	ACTIVE	VQFN	RHB	32	3000	RoHS & Green	NIPDAUAG	Level-2-260C-1 YEAR	-40 to 125	ADS9234	<a href="#">Samples</a>
ADS9234RIRHBT	ACTIVE	VQFN	RHB	32	250	RoHS & Green	NIPDAUAG	Level-2-260C-1 YEAR	-40 to 125	ADS9234	<a href="#">Samples</a>

(1) The marketing status values are defined as follows:

**ACTIVE:** Product device recommended for new designs.

**LIFEBUY:** TI has announced that the device will be discontinued, and a lifetime-buy period is in effect.

**NRND:** Not recommended for new designs. Device is in production to support existing customers, but TI does not recommend using this part in a new design.

**PREVIEW:** Device has been announced but is not in production. Samples may or may not be available.

**OBSELETE:** TI has discontinued the production of the device.

(2) **RoHS:** TI defines "RoHS" to mean semiconductor products that are compliant with the current EU RoHS requirements for all 10 RoHS substances, including the requirement that RoHS substance do not exceed 0.1% by weight in homogeneous materials. Where designed to be soldered at high temperatures, "RoHS" products are suitable for use in specified lead-free processes. TI may reference these types of products as "Pb-Free".

**RoHS Exempt:** TI defines "RoHS Exempt" to mean products that contain lead but are compliant with EU RoHS pursuant to a specific EU RoHS exemption.

**Green:** TI defines "Green" to mean the content of Chlorine (Cl) and Bromine (Br) based flame retardants meet JS709B low halogen requirements of <=1000ppm threshold. Antimony trioxide based flame retardants must also meet the <=1000ppm threshold requirement.

(3) MSL, Peak Temp. - The Moisture Sensitivity Level rating according to the JEDEC industry standard classifications, and peak solder temperature.

(4) There may be additional marking, which relates to the logo, the lot trace code information, or the environmental category on the device.

(5) Multiple Device Markings will be inside parentheses. Only one Device Marking contained in parentheses and separated by a "-" will appear on a device. If a line is indented then it is a continuation of the previous line and the two combined represent the entire Device Marking for that device.

(6) Lead finish/Ball material - Orderable Devices may have multiple material finish options. Finish options are separated by a vertical ruled line. Lead finish/Ball material values may wrap to two lines if the finish value exceeds the maximum column width.

**Important Information and Disclaimer:**The information provided on this page represents TI's knowledge and belief as of the date that it is provided. TI bases its knowledge and belief on information provided by third parties, and makes no representation or warranty as to the accuracy of such information. Efforts are underway to better integrate information from third parties. TI has taken and

continues to take reasonable steps to provide representative and accurate information but may not have conducted destructive testing or chemical analysis on incoming materials and chemicals. TI and TI suppliers consider certain information to be proprietary, and thus CAS numbers and other limited information may not be available for release.

In no event shall TI's liability arising out of such information exceed the total purchase price of the TI part(s) at issue in this document sold by TI to Customer on an annual basis.

**TAPE AND REEL INFORMATION**

**QUADRANT ASSIGNMENTS FOR PIN 1 ORIENTATION IN TAPE**

\*All dimensions are nominal

Device	Package Type	Package Drawing	Pins	SPQ	Reel Diameter (mm)	Reel Width W1 (mm)	A0 (mm)	B0 (mm)	K0 (mm)	P1 (mm)	W (mm)	Pin1 Quadrant
ADS9224RIRHBR	VQFN	RHB	32	3000	330.0	12.4	5.3	5.3	1.5	8.0	12.0	Q2
ADS9234RIRHBR	VQFN	RHB	32	3000	330.0	12.4	5.3	5.3	1.5	8.0	12.0	Q2

**TAPE AND REEL BOX DIMENSIONS**

\*All dimensions are nominal

Device	Package Type	Package Drawing	Pins	SPQ	Length (mm)	Width (mm)	Height (mm)
ADS9224RIRHBR	VQFN	RHB	32	3000	350.0	350.0	43.0
ADS9234RIRHBR	VQFN	RHB	32	3000	350.0	350.0	43.0

## GENERIC PACKAGE VIEW

**RHB 32**

**VQFN - 1 mm max height**

5 x 5, 0.5 mm pitch

PLASTIC QUAD FLATPACK - NO LEAD



Images above are just a representation of the package family, actual package may vary.  
Refer to the product data sheet for package details.

4224745/A

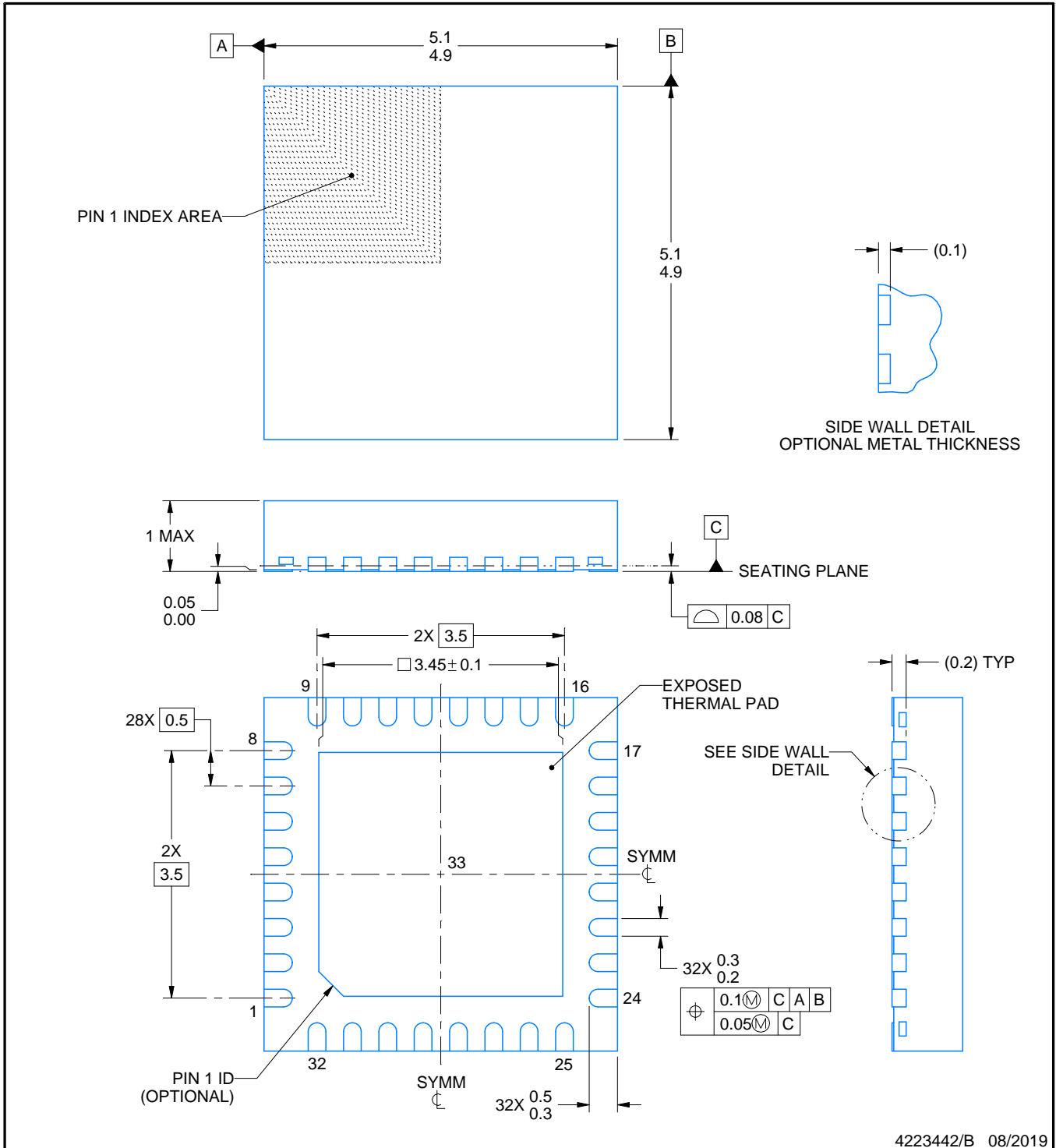

4223442/B 08/2019

NOTES:

1. All linear dimensions are in millimeters. Any dimensions in parenthesis are for reference only. Dimensioning and tolerancing per ASME Y14.5M.
2. This drawing is subject to change without notice.
3. The package thermal pad must be soldered to the printed circuit board for thermal and mechanical performance.

# EXAMPLE BOARD LAYOUT

RHB0032E

VQFN - 1 mm max height

PLASTIC QUAD FLATPACK - NO LEAD



LAND PATTERN EXAMPLE  
SCALE:18X



SOLDER MASK DETAILS

4223442/B 08/2019

NOTES: (continued)

4. This package is designed to be soldered to a thermal pad on the board. For more information, see Texas Instruments literature number SLUA271 ([www.ti.com/lit/sluea271](http://www.ti.com/lit/sluea271)).
5. Vias are optional depending on application, refer to device data sheet. If any vias are implemented, refer to their locations shown on this view. It is recommended that vias under paste be filled, plugged or tented.



# EXAMPLE STENCIL DESIGN

RHB0032E

VQFN - 1 mm max height

PLASTIC QUAD FLATPACK - NO LEAD

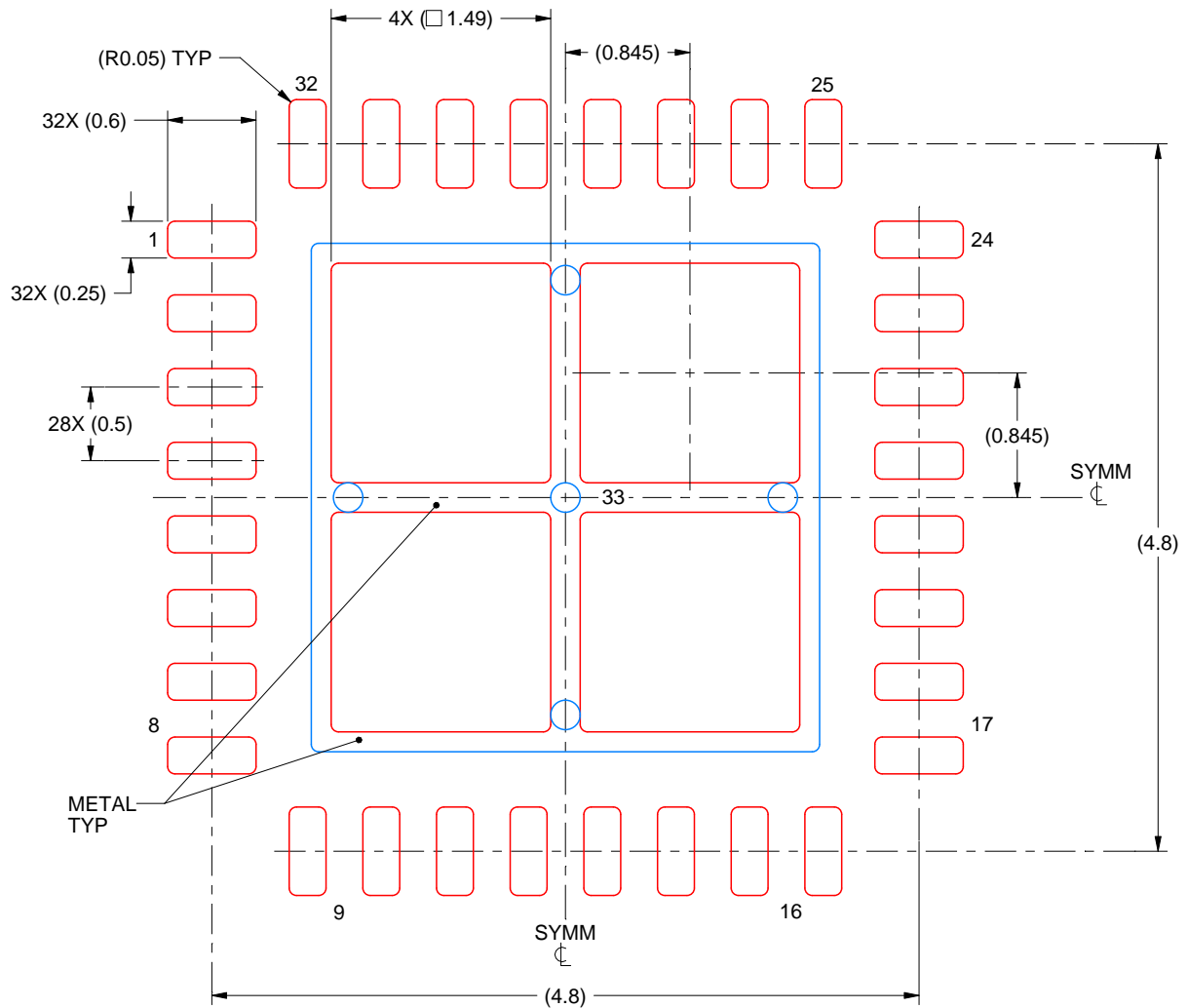

SOLDER PASTE EXAMPLE  
BASED ON 0.125 mm THICK STENCIL

EXPOSED PAD 33:  
75% PRINTED SOLDER COVERAGE BY AREA UNDER PACKAGE  
SCALE:20X

4223442/B 08/2019

NOTES: (continued)

6. Laser cutting apertures with trapezoidal walls and rounded corners may offer better paste release. IPC-7525 may have alternate design recommendations.

## 重要声明和免责声明

TI“按原样”提供技术和可靠性数据（包括数据表）、设计资源（包括参考设计）、应用或其他设计建议、网络工具、安全信息和其他资源，不保证没有瑕疵且不做任何明示或暗示的担保，包括但不限于对适销性、某特定用途方面的适用性或不侵犯任何第三方知识产权的暗示担保。

这些资源可供使用 TI 产品进行设计的熟练开发人员使用。您将自行承担以下全部责任：(1) 针对您的应用选择合适的 TI 产品，(2) 设计、验证并测试您的应用，(3) 确保您的应用满足相应标准以及任何其他功能安全、信息安全、监管或其他要求。

这些资源如有变更，恕不另行通知。TI 授权您仅可将这些资源用于研发本资源所述的 TI 产品的应用。严禁对这些资源进行其他复制或展示。您无权使用任何其他 TI 知识产权或任何第三方知识产权。您应全额赔偿因在这些资源的使用中对 TI 及其代表造成的任何索赔、损害、成本、损失和债务，TI 对此概不负责。

TI 提供的产品受 [TI 的销售条款](#) 或 [ti.com](#) 上其他适用条款/TI 产品随附的其他适用条款的约束。TI 提供这些资源并不会扩展或以其他方式更改 TI 针对 TI 产品发布的适用的担保或担保免责声明。

TI 反对并拒绝您可能提出的任何其他或不同的条款。

邮寄地址：Texas Instruments, Post Office Box 655303, Dallas, Texas 75265

Copyright © 2023，德州仪器 (TI) 公司