

Using a Programmable Input Multiplier to Minimize Integer Boundary Spurs

Dean Banerjee

ABSTRACT

The concept of using a programmable input multiplier, also nicknamed Spur-b-Gone, allows the spurs of a PLL to be drastically improved, especially for the worst case VCO frequencies. This can be done without changing the input frequency, as this is purely implemented inside the PLL. This feature is included on some TI PLLs, such as the LMX2571.

Contents

1	Brief PLL Overview	2
2	Understanding Integer Boundary Spurs	2
3	Spur-b-Gone Concept	3
4	Usage of the Programmable Input Multiplier	3
5	Understanding Spur-b-Gone in More Depth and How the <i>Spur-b-Gone</i> Button Works on CodeLoader	4

1 Brief PLL Overview

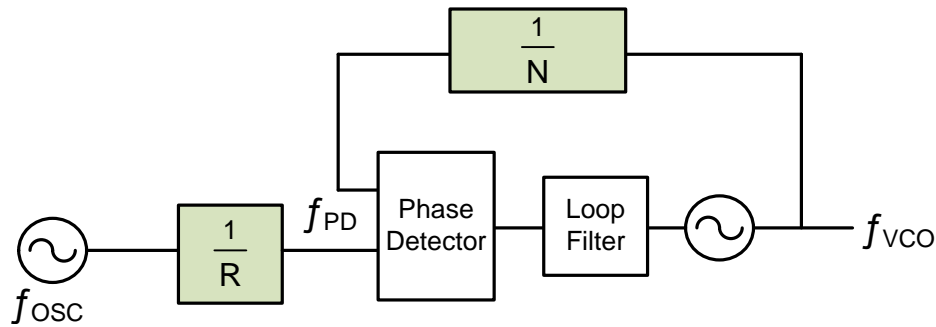

Figure 1. Basic PLL

The PLL (Phased Locked Loop) starts with a fixed frequency (f_{osc}) and may divide it down by an integer R divider value (R) to get the phase detector frequency (f_{PD}).

$$f_{\text{PD}} = \frac{f_{\text{osc}}}{R} \quad (1)$$

The VCO frequency (f_{VCO}) is divided down by the N divider value (N) to also get the phase detector frequency. The N divider may be a fraction. The phase detector compares the N and R divider outputs and puts out correction pulses to the loop filter, which in turn converts this to a voltage. This voltage is converted to a frequency by the Voltage Controlled Oscillator (VCO). The input and output frequencies are related as shown in [Equation 2](#).

$$f_{\text{VCO}} = N \times f_{\text{PD}} = f_{\text{VCO}} \times \frac{N}{R} \quad (2)$$

2 Understanding Integer Boundary Spurs

When the N divider value is not an integer, it is possible to have the integer boundary spur. This spur is typically the most troublesome one and occurs at an offset (f_{spur}) equal to the difference of the VCO Frequency and the closest multiple of the phase detector frequency.

$$f_{\text{spur}} = f_{\text{VCO}} \% f_{\text{PD}} \quad (3)$$

For instance, the system in [Table 1](#) would have worst case channels of 2000.1, 2019.9, 2020.1, 2039.9, and 2040.1 MHz. For all these channels, these would be the worst case for the closest integer boundary the spur offset frequency of 100 kHz.

Table 1. Integer Boundary Spur Example

PARAMETER	VALUE
f_{osc}	20 MHz
f_{PD}	20 MHz
f_{VCO}	2000 – 2050 MHz
Channel Spacing	0.1 MHz

3 Spur-b-Gone Concept

The concept of Spur-b-Gone is to put a multiplier after the input frequency so that the phase detector frequency can be dynamically changed to avoid bad integer boundary spurs.

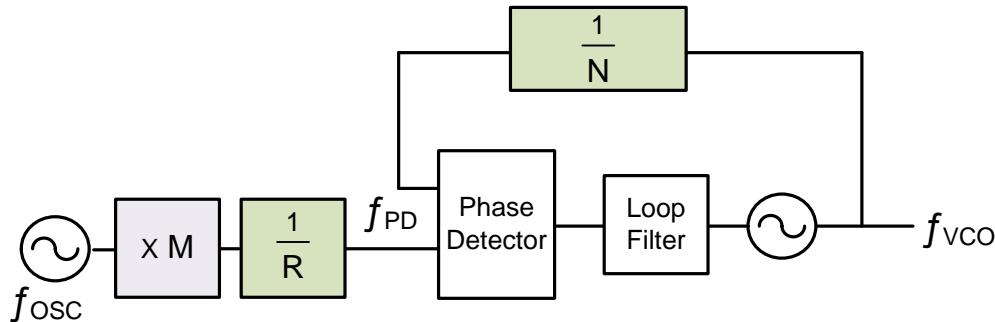

Figure 2. Architecture for Avoiding Spurs

For the example in [Table 1](#), one could change the multiplier value (M) to three and the R divider to two in order to get a 30-MHz phase detector frequency and avoid the integer boundary spurs. It is true that changing the phase detector frequency in this way does change the loop dynamics, but the charge pump can be used to compensate. In this case, when the phase detector is increased from 20 to 30 MHz, which multiplying by 1.5, then the charge pump gain would ideally be divided down by 1.5.

4 Usage of the Programmable Input Multiplier

Consider the example in [Table 2](#), comparing a regular application (no Spur-b-Gone) to an application using a Spur-b-Gone. We see that there is a significant improvement in the VCO integer boundary spur. Also, because this integer boundary spur can mix and be divided down to form other spurs, we also see a ripple effect where other spurs that are derived from this main integer boundary spur at 100 kHz are also reduced.

Table 2. Spur-b-Gone Example

PARAMETER	REGULAR	SPUR-B-GONE
f_{osc}	20 MHz	20 MHz
R	1	3
M	1	4
f_{PD}	20 MHz	26.66.. MHz
f_{VCO}	5400.1 MHz	5400.1 MHz
Output Frequency	540.01 MHz	540.01 MHz
VCO Integer Boundary Spur at 100 kHz Offset	-63 dbc	-70 dBc
½ VCO Integer Boundary Spur at 50 kHz Offset	-59 dBc	-72 dBc
1/10 Integer Boundary Spur at 10 kHz Offset	-53 dBc	< -72 dBc

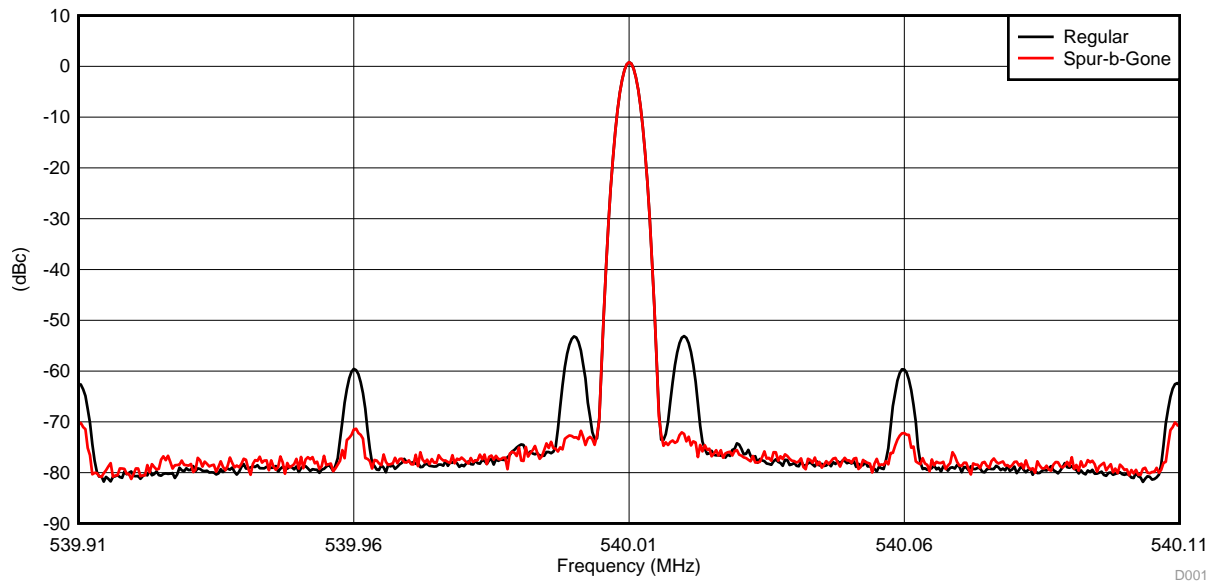

Figure 3. Spur-b-Gone Example

As we see in [Figure 3](#), not only has the VCO integer boundary spur been reduced, but many other spurs are also impacted as this goes through the divider. Note that the charge pump current was adjusted to keep the same loop bandwidth. The loop filter was the default one on the LMX2571 evaluation with maximum charge pump gain for the regular case, but this is not critical, as the key point is the relative change in the spur levels that is achieved by Spur-b-Gone.

5 Understanding Spur-b-Gone in More Depth and How the Spur-b-Gone Button Works on CodeLoader

The general concept in using Spur-b-Gone is to maximize the distance from the integer boundaries. However, it also turns out that if one is close to or at the midpoint of two integer channels, then again the spurs will be higher, although not as bad as being right at the integer boundary. Also, as the multiplier value becomes too large, then it also can add noise.

The *Spur-b-Gone* button on CodeLoader works by iterating through all valid PLL_R_PRE, PLL_R and MULT values and calculates an index for each one. Then it chooses the highest (best) index. The index works by putting 40x more weight on the distance to the closest integer channel compared to the midpoint and doing a parallel combination of these. Then it divides by the multiplier value to discourage higher multiplier values unless it provides some benefit.

```

IBS = Fvco % Fpd (Distance to closest integer channel)
IBS2 = Fvco % (Fpd/2) (Distance to closest midpoint between 2 integer channels)
If IBS = 0 then
Index = Infinite (Ideal to be exactly on an integer channel)
Else If IBS2=0 then
Index = 0 (Stay away from 1/2 of integer boundary)
Else
If IBS<IBS2 then
Index = IBS / Mult
Else
Index = IBS * (40 * IBS2) / (IBS + 40 * IBS2) / Mult
End If
End If
    
```

IMPORTANT NOTICE FOR TI DESIGN INFORMATION AND RESOURCES

Texas Instruments Incorporated ("TI") technical, application or other design advice, services or information, including, but not limited to, reference designs and materials relating to evaluation modules, (collectively, "TI Resources") are intended to assist designers who are developing applications that incorporate TI products; by downloading, accessing or using any particular TI Resource in any way, you (individually or, if you are acting on behalf of a company, your company) agree to use it solely for this purpose and subject to the terms of this Notice.

TI's provision of TI Resources does not expand or otherwise alter TI's applicable published warranties or warranty disclaimers for TI products, and no additional obligations or liabilities arise from TI providing such TI Resources. TI reserves the right to make corrections, enhancements, improvements and other changes to its TI Resources.

You understand and agree that you remain responsible for using your independent analysis, evaluation and judgment in designing your applications and that you have full and exclusive responsibility to assure the safety of your applications and compliance of your applications (and of all TI products used in or for your applications) with all applicable regulations, laws and other applicable requirements. You represent that, with respect to your applications, you have all the necessary expertise to create and implement safeguards that (1) anticipate dangerous consequences of failures, (2) monitor failures and their consequences, and (3) lessen the likelihood of failures that might cause harm and take appropriate actions. You agree that prior to using or distributing any applications that include TI products, you will thoroughly test such applications and the functionality of such TI products as used in such applications. TI has not conducted any testing other than that specifically described in the published documentation for a particular TI Resource.

You are authorized to use, copy and modify any individual TI Resource only in connection with the development of applications that include the TI product(s) identified in such TI Resource. NO OTHER LICENSE, EXPRESS OR IMPLIED, BY ESTOPPEL OR OTHERWISE TO ANY OTHER TI INTELLECTUAL PROPERTY RIGHT, AND NO LICENSE TO ANY TECHNOLOGY OR INTELLECTUAL PROPERTY RIGHT OF TI OR ANY THIRD PARTY IS GRANTED HEREIN, including but not limited to any patent right, copyright, mask work right, or other intellectual property right relating to any combination, machine, or process in which TI products or services are used. Information regarding or referencing third-party products or services does not constitute a license to use such products or services, or a warranty or endorsement thereof. Use of TI Resources may require a license from a third party under the patents or other intellectual property of the third party, or a license from TI under the patents or other intellectual property of TI.

TI RESOURCES ARE PROVIDED "AS IS" AND WITH ALL FAULTS. TI DISCLAIMS ALL OTHER WARRANTIES OR REPRESENTATIONS, EXPRESS OR IMPLIED, REGARDING TI RESOURCES OR USE THEREOF, INCLUDING BUT NOT LIMITED TO ACCURACY OR COMPLETENESS, TITLE, ANY EPIDEMIC FAILURE WARRANTY AND ANY IMPLIED WARRANTIES OF MERCHANTABILITY, FITNESS FOR A PARTICULAR PURPOSE, AND NON-INFRINGEMENT OF ANY THIRD PARTY INTELLECTUAL PROPERTY RIGHTS.

TI SHALL NOT BE LIABLE FOR AND SHALL NOT DEFEND OR INDEMNIFY YOU AGAINST ANY CLAIM, INCLUDING BUT NOT LIMITED TO ANY INFRINGEMENT CLAIM THAT RELATES TO OR IS BASED ON ANY COMBINATION OF PRODUCTS EVEN IF DESCRIBED IN TI RESOURCES OR OTHERWISE. IN NO EVENT SHALL TI BE LIABLE FOR ANY ACTUAL, DIRECT, SPECIAL, COLLATERAL, INDIRECT, PUNITIVE, INCIDENTAL, CONSEQUENTIAL OR EXEMPLARY DAMAGES IN CONNECTION WITH OR ARISING OUT OF TI RESOURCES OR USE THEREOF, AND REGARDLESS OF WHETHER TI HAS BEEN ADVISED OF THE POSSIBILITY OF SUCH DAMAGES.

You agree to fully indemnify TI and its representatives against any damages, costs, losses, and/or liabilities arising out of your non-compliance with the terms and provisions of this Notice.

This Notice applies to TI Resources. Additional terms apply to the use and purchase of certain types of materials, TI products and services. These include; without limitation, TI's standard terms for semiconductor products (<http://www.ti.com/sc/docs/stdterms.htm>), [evaluation modules](#), and [samples](http://www.ti.com/sc/docs/sampterm.htm) (<http://www.ti.com/sc/docs/sampterm.htm>).

Mailing Address: Texas Instruments, Post Office Box 655303, Dallas, Texas 75265
Copyright © 2017, Texas Instruments Incorporated