

Functional Safety FIT Rate, Failure Mode Distribution TPS382x-Q1

Voltage Monitor With Watchdog Timer

Functional Block Diagram

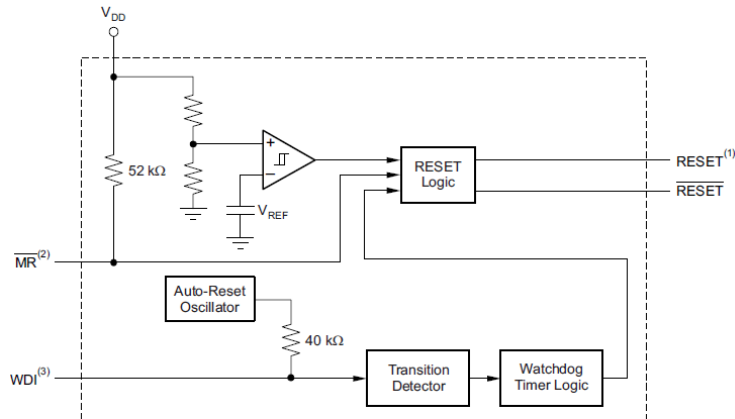

- (1) TPS3824/5-xx-Q1
 (2) TPS3820/3/5/8-xx-Q1
 (3) TPS3820/3/4/8-xx-Q1

FIT IEC TR 62380 / ISO 26262-11 (1)	Per 10 ⁹ Hours (FIT)
Total FIT Rate	4
Die FIT Rate	2
Package FIT Rate	2

FIT Siemens Norm SN29500 (2)			
Table	Category	Ref FIT λ_{ref}	Ref Virtual Tj $\theta_{vj,1}$
Table 5	Digital, Analog, Mixed	20 FIT	55 C

Failure Modes	Failure Mode Distribution (%)
nRESET (or RESET) fails to trip	20%
nRESET (or RESET) false trip	20%
nRESET (or RESET) trip outside specification (voltage or time)	55%
Pin to Pin short any two pins	5%

Failure Rate, Mission Profile and Failure Modes Distribution

The failure rate and mission profile information come from reliability modeling for Integrated circuits in Reliability data handbook IEC TR 62380 and ISO 26262 Part 11

Mission Profile: Motor Control from Table 11

Power dissipation 0.5 mW

Climate type: World-wide Table 8

Package factor lambda 3 Table 17b

Substrate Material: FR4

EOS FIT rate assumed = 0

(2) Reference failure rate, Virtual (equivalent) junction temperature

The reference failure rate and virtual junction temperature come from Siemens Norm SN29500-2 tables 1-5. Failure rate for user mission profile is calculated using the reference failure rate and virtual junction temperature and following the calculation information in SN29500-2 section 4.

The failure mode distribution estimation comes from the combination of common failure modes listed in standards such as IEC 61508 and ISO 26262, the ratio of sub-circuit function size and complexity and from best engineering judgment. The failure rates listed reflect random failure events and do not include failures due to misuse or over stress.

TPS382x-Q1 are catalog products and not compliant to ISO-26262 standards.

IMPORTANT NOTICE AND DISCLAIMER

TI PROVIDES TECHNICAL AND RELIABILITY DATA (INCLUDING DATASHEETS), DESIGN RESOURCES (INCLUDING REFERENCE DESIGNS), APPLICATION OR OTHER DESIGN ADVICE, WEB TOOLS, SAFETY INFORMATION, AND OTHER RESOURCES "AS IS" AND WITH ALL FAULTS, AND DISCLAIMS ALL WARRANTIES, EXPRESS AND IMPLIED, INCLUDING WITHOUT LIMITATION ANY IMPLIED WARRANTIES OF MERCHANTABILITY, FITNESS FOR A PARTICULAR PURPOSE OR NON-INFRINGEMENT OF THIRD PARTY INTELLECTUAL PROPERTY RIGHTS.

These resources are intended for skilled developers designing with TI products. You are solely responsible for (1) selecting the appropriate TI products for your application, (2) designing, validating and testing your application, and (3) ensuring your application meets applicable standards, and any other safety, security, or other requirements. These resources are subject to change without notice. TI grants you permission to use these resources only for development of an application that uses the TI products described in the resource. Other reproduction and display of these resources is prohibited. No license is granted to any other TI intellectual property right or to any third party intellectual property right. TI disclaims responsibility for, and you will fully indemnify TI and its representatives against, any claims, damages, costs, losses, and liabilities arising out of your use of these resources.

TI's products are provided subject to TI's Terms of Sale (www.ti.com/legal/termsofsale.html) or other applicable terms available either on ti.com or provided in conjunction with such TI products. TI's provision of these resources does not expand or otherwise alter TI's applicable warranties or warranty disclaimers for TI products.

Mailing Address: Texas Instruments, Post Office Box 655303, Dallas, Texas 75265
Copyright © 2020, Texas Instruments Incorporated