

## 设计指南: TIDA-020023

# 采用高精度电流传感器的汽车比例电磁阀驱动器参考设计



### 说明

此参考设计对使用简单推挽式输出比较器和高精度集成电流并联监控器的比例电磁阀驱动器进行了说明。为实现更平稳的汽车驾驶性能,特别需要在车辆自动变速器的多处部位对比例电磁阀进行精确控制。该电流设计旨在解决影响螺线管精确位置的两个主要因素。这两个因素就是温度范围内的驱动精度和电流检测精度。

### 资源

<a href="#">TIDA-020023</a>	设计文件夹
<a href="#">INA253</a>	产品文件夹
<a href="#">TLV1805-Q1</a>	产品文件夹
<a href="#">TPS709-Q1</a>	产品文件夹



咨询我们的 E2E™ 专家

### 特性

- 电流检测精度为 0.5%
- 驱动频率和占空比: 1kHz
- 具有集成分流器,可在更大的动态范围内实现更高精度
- 更低的温漂
- 宽共模范围: -4V 至 80V
- 具有增强型 PWM 抑制功能的高侧驱动、高侧电磁阀监视器

### 应用

- [自动变速器](#)
- [换挡系统](#)
- [传动系组件](#)

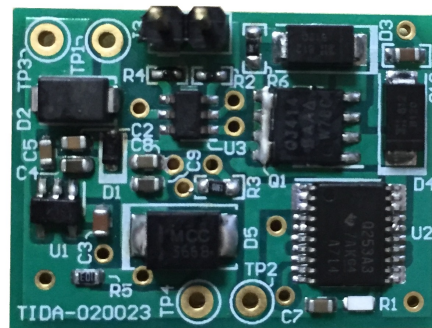
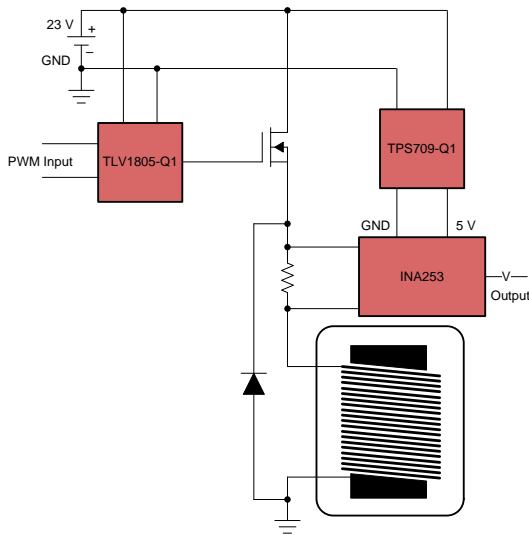

该 TI 参考设计末尾的重要声明表述了授权使用、知识产权问题和其他重要的免责声明和信息。

## 1 System Description

Many automotive applications use proportional solenoids where precise control of these solenoids provides a smoother driving experience. Proportional solenoids are also used in automatic transmissions in gear shifting, clutch shifting, hydraulic fluid pumps and so forth. The drivability of a solenoid is mainly dependant on two factors: solenoid drive and solenoid position sense.

1. Solenoid drive: Higher duty cycle and larger PWM frequency increases the dynamic range of the solenoid. A high-side switch along with a push-pull output amplifier do the job of driving the solenoid.

A solenoid is connected to the N-channel switch and to the ground. Precise control of the N-channel switch is controlled by a TLV1805 device. The TLV1805 input is a duty cycle from the microcontroller. The microcontroller duty cycle is changed based on the information from the sensor, this way closed loop control is achieved and thus precise control of the solenoid is achieved.

2. Current Sense (Solenoid position sense): Current sense is used to estimate the position of a solenoid. the information is fed back to the microcontroller, where solenoid position information is estimated and adjusts the duty cycle based on this. TI's Integrated current shunt monitor is used to solve this need.

This reference design injects the average current to flow through the solenoid in a closed-loop control with the use of a varying PWM duty cycle. In a closed-loop-control proportional solenoid, the duty cycle varies with respect to solenoid drifts, which means that the duty cycle requires adjustment based on the current sensor information. Based on the information from the solenoid position-based current sensor, the duty cycle is changed to move the solenoid precisely.

### 1.1 Key System Specifications

表 1. Key System Specifications

PARAMETER	SPECIFICATIONS	DETAILS
input power source	12-V battery ( evaluating lab power supply)	
Sensor type	Shunt (resistive), <b>integrated</b>	
Solenoid current consumption	700-mA solenoid	
Shunt value	2 mΩ	
Max current through shunt	15 A (1 A with the current solenoid used)	
Duty cycle	1 kHz	
Form factor	27 mm x 20 mm	
Operating temperature	-40°C to +125°C	

## 2 System Overview

### 2.1 Block Diagram

图 1. TIDA-020023 Block Diagram

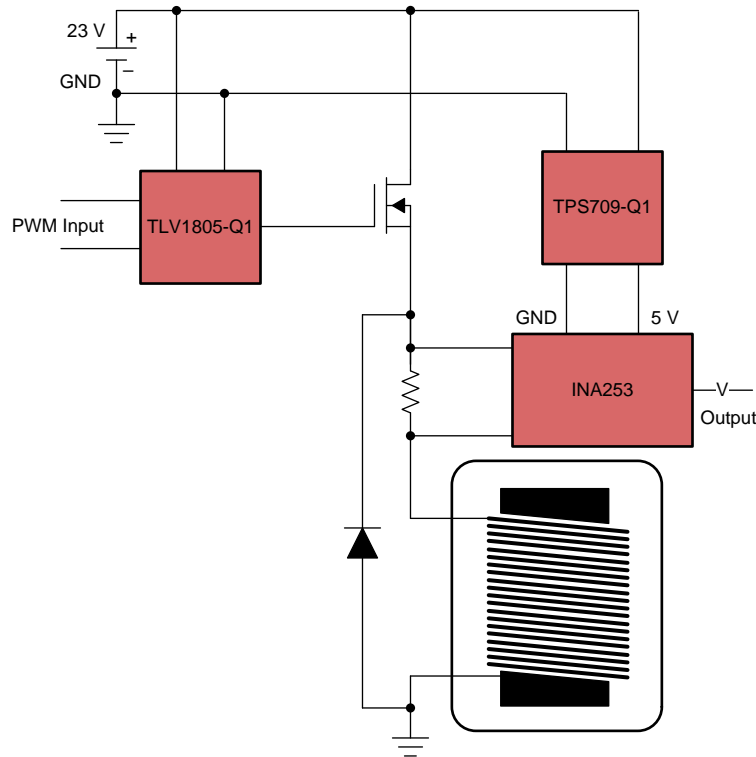

TLV1805-Q1: Used as a gate driver. A high-voltage comparator is used as a solenoid driver along with the discrete charge pump to drive the N-channel FET

TPS709-Q1: LDO generates 5 V for the current shunt monitor

INA253: Integrated shunt type current shunt sense amplifier

Solenoid: Connected in series with the N-channel switch and to the ground

### 2.2 Design Considerations

This reference design facilitates different types of solenoids with various current ranges, to connect to the system with minimal changes to the MOSFET. A current-sense amplifier can still accommodate up to 15-A solenoids. The current-sense block output is sent to the microcontroller. The microcontroller operates the duty cycle based on the current-sensor information and drives the solenoid.

### 2.3 Highlighted Products

#### 2.3.1 INA253-Q1

The main need for a low-drift current sensor is for the proportional solenoid application to close the loop to provide the current sensor feedback. The INA253-Q1 device has an integrated shunt of 2mΩ with **X** inductance facilitating very low drift over temperature.

The INA253 device is a voltage-output, current sense amplifier with an integrated shunt resistor of 2 m $\Omega$ . The INA253 is designed to monitor bidirectional currents over a wide common-mode range from  $-4$  V to  $+80$  V, independent of the supply voltage. Three fixed gains are available: 100 mV/A, 200 mV/A, and 400 mV/A. Based on the solenoid current rating, the respective gain must be selected. The integration of the precision resistor with a zero-drift chopped amplifier provides calibration equivalent measurement accuracy, ultra-low temperature drift performance of 15 ppm/ $^{\circ}$ C, and an optimized Kelvin layout for the sensing resistor. The INA253 device is designed with enhanced PWM rejection circuitry to suppress large (dv/dt) signals that enable real-time continuous current measurements.

### 2.3.2 TLV1805-Q1

The TLV1805-Q1 device is a high-voltage comparator used as a drive for the N-channel switch to facilitate the PWM drive. With 85 mA of output push-pull current stage and a power supply of 40 V, this device is suitable for the current application.

The following features make this comparator well-suited for applications that require faster switching and higher duty cycles:

- Rail-to-rail inputs
- Low quiescent current
- Shutdown
- Fast output response

The high peak current push-pull output stage which is unique for high-voltage comparators, offers the advantage of allowing the output to actively drive the load to either supply rail with a fast edge rate. This is especially valuable in applications where a MOSFET switch needs to be driven high or low to connect or disconnect a host from an unexpected high-voltage supply. Additional features such as low input offset voltage, low input bias currents and High Z shutdown make the TLV1805-Q1 device flexible enough to handle almost any application, from simple voltage detection to driving a single relay. The TLV1805-Q1 device is AEC-Q100 qualified in a 6-pin SOT-23 package and is specified for operation across the temperature range of  $-40^{\circ}$ C to  $+125^{\circ}$ C.

### 2.3.3 TPS709-Q1

The TPS709-Q1 series of linear regulators are ultra-low quiescent current devices designed for power sensitive applications. A precision band-gap and error amplifier provides 2% accuracy over temperature. A quiescent current of only 1  $\mu$ A makes these devices ideal solutions for battery-powered, always-on systems that require very little idle-state power dissipation. These devices have thermal-shutdown, current-limit, and reverse-current protections for added safety. These regulators can be put into shutdown mode by pulling the EN pin low. The shutdown current in this mode goes down to 150 nA, typical. The TPS709-Q1 series is available in WSON-6 and SOT-23-5 packages.

## 2.4 System Design Theory

Solenoids convert electrical current into mechanical motion—from a fundamental perspective, a solenoid is simply a linear motor with a fixed range of travel. Solenoids are available in two basic types: on and off solenoids and linear and proportional solenoids. Solenoids of the on and off type convert electrical information into mechanical information through the closing or opening of valves. Proportional solenoids convert electrical signals into proportional mechanical force, which allows variance in armature position

and force relative to the current level. In applications such as automatic transmissions and fuel injection, proportional solenoids serve to operate pistons and valves to accurately control fuel pressure or flow. Transmission applications require accurate and smooth control of pressure to change gears seamlessly. The primary focus of this reference design is on proportional solenoids drive and solenoid current monitoring. The measured current is fed back to the control unit where precise PWM control is adjusted.

Current sensors in solenoid applications follow a shunt-based principle. In this principle, averaged pulsated current made to flow on the 2 mΩ using the PWM method and using an N-channel MOSFET switch. The drop across the 2-mΩ shunt is captured using a current-shunt amplifier. The current sensor is sensitive to temperature and other noise drifts; therefore, selecting a current sensor with low drift, low noise, and an enhanced PWM rejection is vital. The INA253-Q1 device from TI's current shunt sensor portfolio perfectly suits these kinds of applications. The device has an integrated shunt of 2 mΩ, which facilitates the lower drifts over temperature and implies more accurate readings from the current sensors. In this design, a freewheeling path has been created from the solenoid back to the shunt to account for the solenoid recirculation currents. A shunt is inserted between the high-side switch and solenoid to capture the recirculation events (see 图 1).

### 2.4.1 Characteristics of Solenoid Coils

Electromechanical solenoids consist of an electromagnetically-inductive coil wound around a movable steel or iron slug, which is known as the armature or plunger (see 图 2). The coil is shaped such that the armature can be moved in and out of its center, altering the inductance of the coil as well as effectively making it an electromagnet. The armature provides a mechanical force to activate the control mechanism, for example, opening and closing of a valve or linear movement of the solenoid.

**图 2. Electromechanical Solenoid Characteristics**

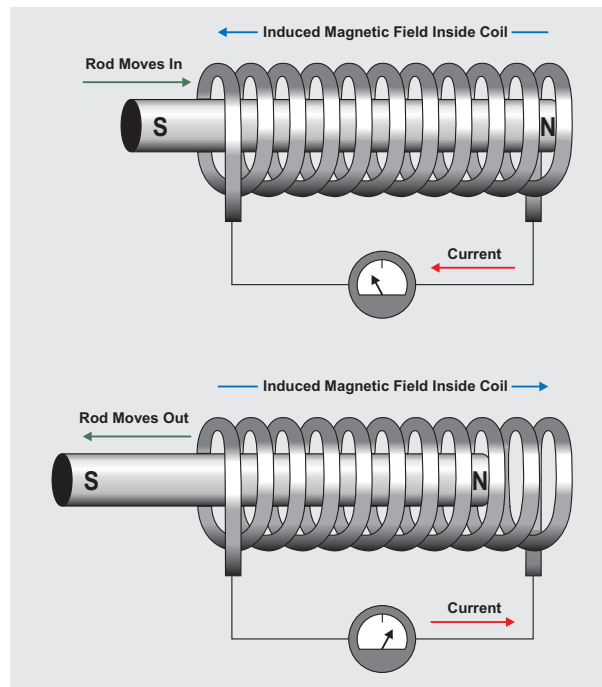

The main electrical characteristic of a solenoid is that of an inductor that opposes any change in current. This characteristic is why current does not immediately reach a maximum level upon energizing a solenoid. Instead, the current rises at a steady rate until the DC resistance of the solenoid imposes a limit. An inductor (in this case a solenoid) stores energy in the form of a concentrated magnetic field. Whenever current is present in a wire or conductor, a magnetic field, however small, is created around the wire. With the wire wound into a coil, such as in a solenoid, the magnetic field becomes very concentrated. This electromagnet can control a mechanical valve through an electrical signal. As soon as the solenoid is energized, the current increases, which causes the magnetic field to expand until it becomes strong enough to move the armature. The amount of magnetic field is proportional to the amount of current injected which, in turn, is proportional to the solenoid movement.

### 2.4.2 Closed-Loop Control of Proportional Solenoid

图 3 shows the mechanism to control the proportional solenoid in a closed-loop fashion. The inner loop represents the current control and the outer loop represents the pressure control. Using a varied duty cycle, the current set point has a value with which to operate  $G1(s)$ .  $G1(s)$  translates current into armature motion. A high-accuracy current sensor detects solenoid movement, which adjusts the current set point to give the next instruction to the  $G1(s)$ . This order of events forms a closed loop and achieves precise control of the solenoid. This criteria similarly applies to pressure loops.

图 3. Controlling a Solenoid With a Closed Loop

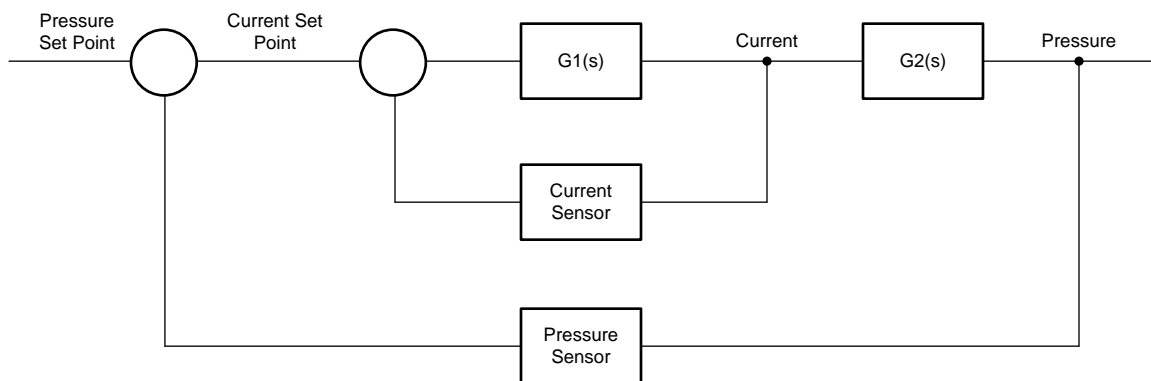

One function of a feedback loop is to control the position of a linear solenoid. For example, the designer can monitor the downstream pressure of a valve, use it as a feedback signal to compare with the setpoint, and adjust the PWM duty cycle to control the solenoid. However, measuring the downstream pressure may be difficult, impractical, or very costly. A practical alternative to measuring the downstream pressure is to establish the position of the solenoid by measuring the current through the solenoid. This measurement is possible because the force imposed by the mechanical load on a solenoid is directly proportional to the magnetic field, which, in turn, is directly proportional to the current through the coil. Proportional control of the solenoid is achieved by a balance of the forces between the spring-type load and the magnetic field of the solenoid, which the designer can determine by measuring the current through the solenoid.

### 2.4.3 Solenoid Drive With High-Voltage Comparator and N-Channel Switch

图 4 shows the simulation diagram of solenoid drive. High-voltage comparator output is connected to the N-channel MOSFET gate.

图 4. Simulation Circuit Diagram for Solenoid Drive Using TLV1805-Q1

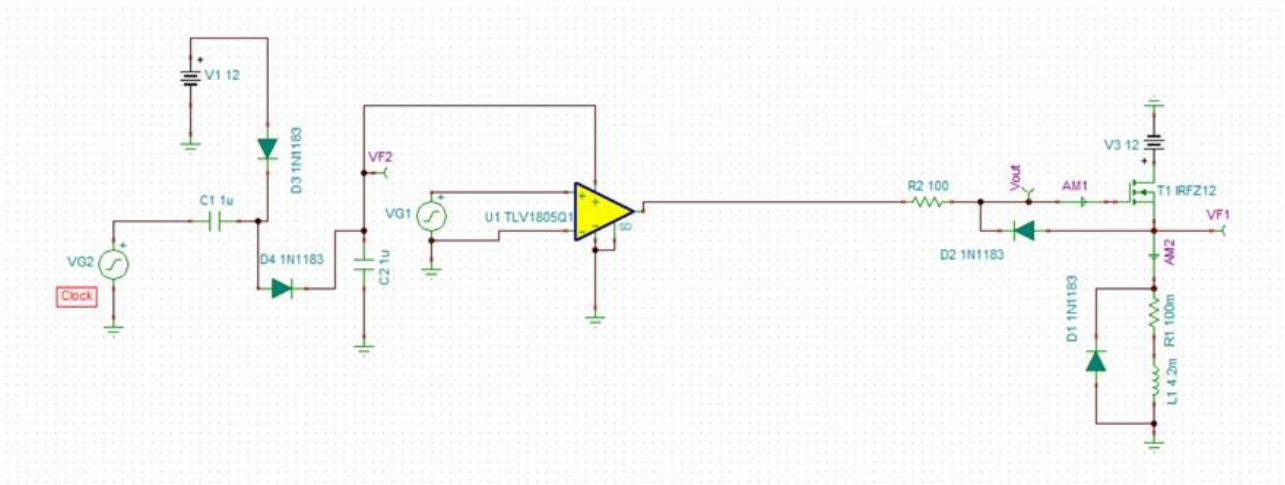

VG1 is a PWM waveform given to the comparator input terminals, with a voltage level; of 1 V. Normally it is applied from the microcontroller and can be adjusted till 3.3 V. The comparator has a supply of 24 V. This 24 V is generated from the oscillator. An oscillator can be made with another TLV1805-Q1 device connected in a oscillator fashion. Based on the input, the PWM signal output of the comparator changes between 0 and 24 V. This results in a 24-V voltage across the gate input of the MOSFET. The 24 V is required because the N-channel is connected on the high side and it needs to be maintained as a  $V_{GS}$  threshold.

图 5. Simulation Waveforms



图 5 shows the simulation circuit waveforms. AM2 is the current which flows through the solenoid. Based on the VG1 duty cycle change, the amount of current which flows through the solenoid changes.

- AM1 is the current that flows through the gate terminal
- AM2 is the current that flows through the solenoid

- VF1 is the voltage at the MOSFET source terminal
- VG1 is the voltage at the input terminals of the high-voltage comparator
- V1 is the 12-V terminal
- V2 is ground
- $V_{OUT}$  is the output voltage of the comparator

注: In the schematics, 24 V is directly connected from the lab power supply. Based on the availability, 24 V can be generated as suggested in the previously-described setup or directly with a 24 V supply.

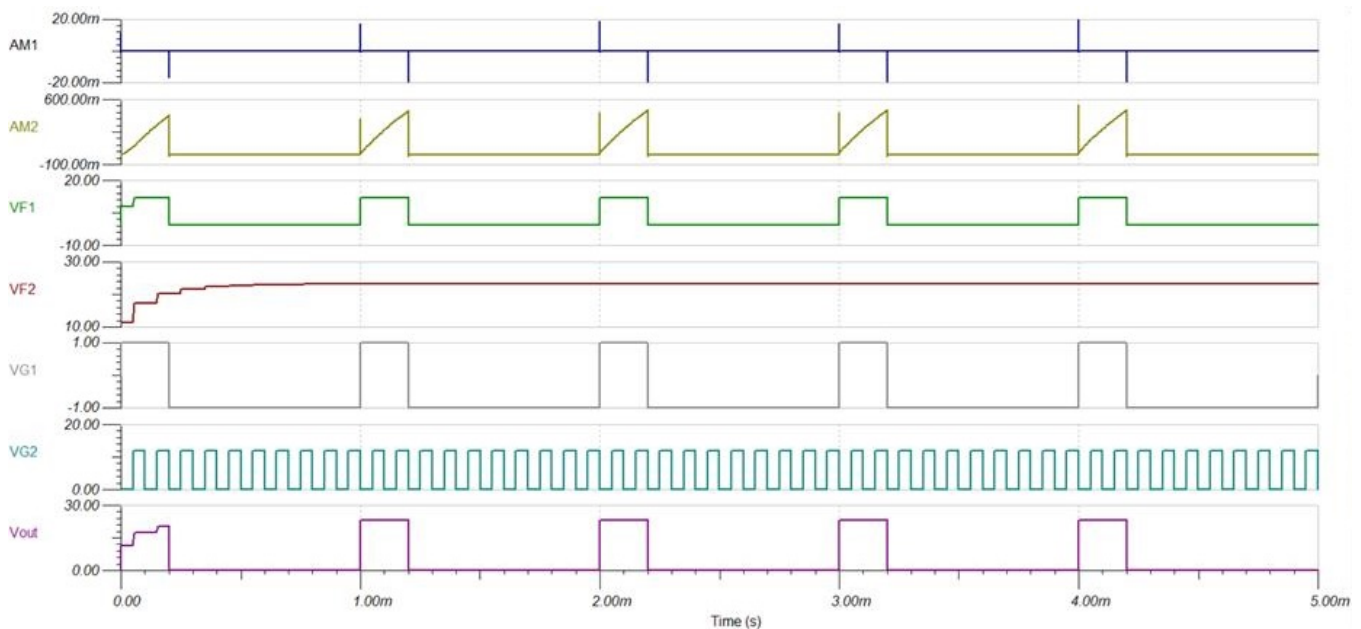
### 2.4.4 Solenoid Current Sense

图 6 shows the solenoid current-sense schematic circuit diagram. The shunt is internal and is  $2\text{ m}\Omega$ , with very low inductance in the order of  $3\text{ nH}$ . A shunt is connected on the low side as the block diagram section shows. One end of the shunt is connected to the MOSFET source terminals and other end is connected to the solenoid positive terminal. IS+ is connected to the MOSFET source terminal and is connected to the solenoid terminals. based on the configuration and specifications of the solenoids Less than 1 A of current flows through the solenoid and the flyback signal is carried over by a clamping diode. When the switch is ON, current flows through the solenoid and when the switch is OFF, suddan changes in the curent, inductance cannot tolerate so a clamp occures which goes through the clamping diode for suppression. To detect these clamps clamping diode is connected on top of shunt.

图 6. Current Sense Circuit

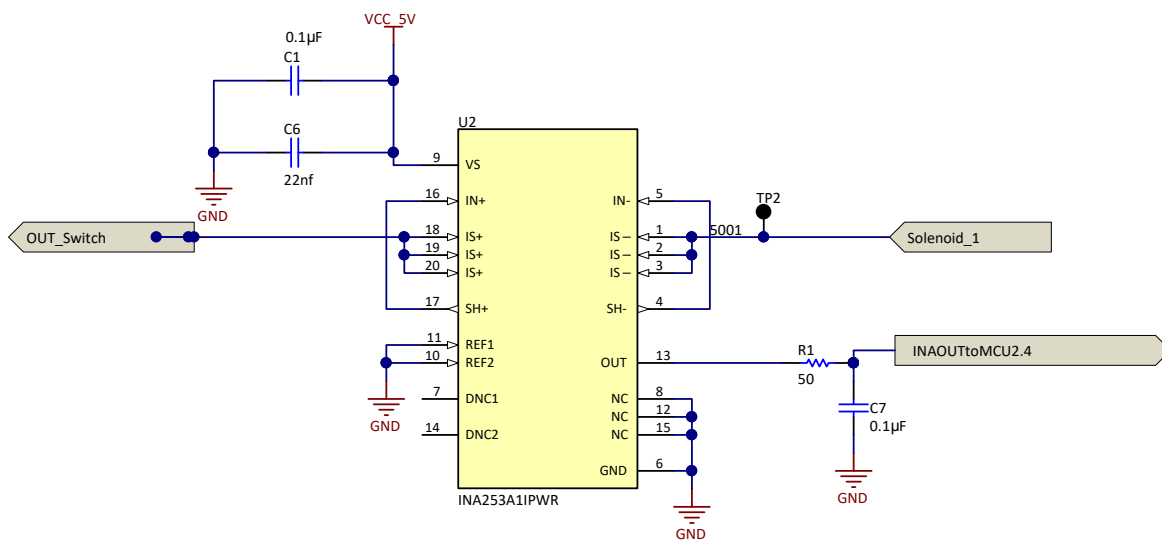

Current sense accuracy is critical, especially in solenoid applications. Current sense information is fed back to the control loop and the controller adjusts the PWM signal so that precise position of the solenoid is maintained.

### 2.4.5 Solenoid Current

图 7 shows the solenoid used in this reference design. The solenoid has the following specifications:

- $R = 16.7\ \Omega$



- $V = 12\text{ V}$

These specifications mean there is a current flow of  $I = 718\text{ mA}$  when the MOSFET is in 'ON' position there is flow of  $718\text{ mA}$  through the solenoid. This amperage is the needed current to make the solenoid fully ON. The three terminals in [图 7](#) are positive, ground and earthing.

**图 7. MSM GRFY060F20B01 Solenoid**



## **3 Hardware, Software, Testing Requirements, and Test Results**

### **3.1 Required Hardware and Software**

#### **3.1.1 Hardware**

##### **3.1.1.1 Required Hardware**

The equipment needed for testing the TIDA-020023 follows.

- Function, waveform generator
- Power supply
- Oscilloscope
- Current probe
- Multimeter
- Source meter
- Solenoid

##### **3.1.1.2 Hardware Test Setup**

For the purposes of testing, the TIDA-020023 design was connected to a MSM GRFY060F20B01 solenoid. See [节 2.4.5](#) for solenoid details. Hardware tests on the TIDA-020023 are done in two ways:

1. Functionality checks
2. Accuracy tests

Functionality checks are performed to test the circuit functionally of the solenoid driver with the TLV1805-Q1 device and the INA253 current sense schematic. [图 8](#) shows the test setup for the functionality checks.

图 8. Test Setup for the Functionality Checks

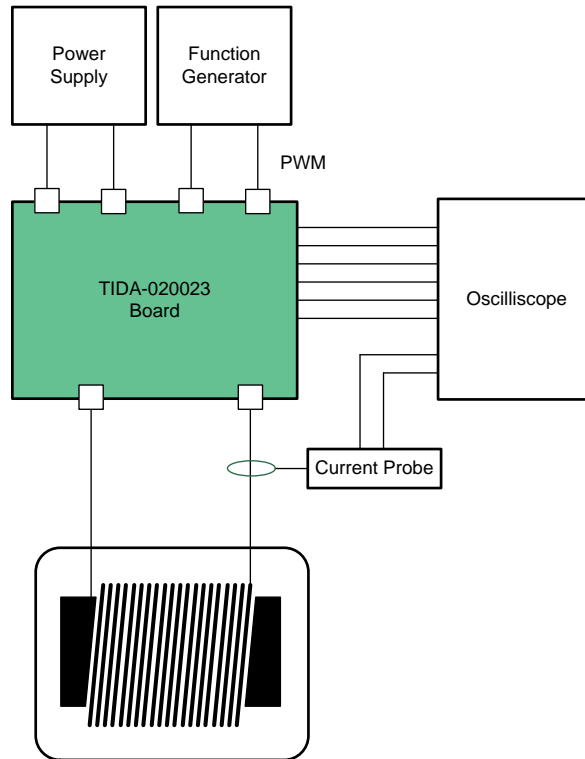

Accuracy tests are performed for estimating the accuracy performance of the INA253-Q1 device. With the solenoid connected and input and output multimeters connected, the accuracy is estimated as per 图 9.

图 9. Test Setup for the Accuracy Tests



图 10 shows the test setup in the lab.

图 10. TIDA-020023 Test Setup in Lab

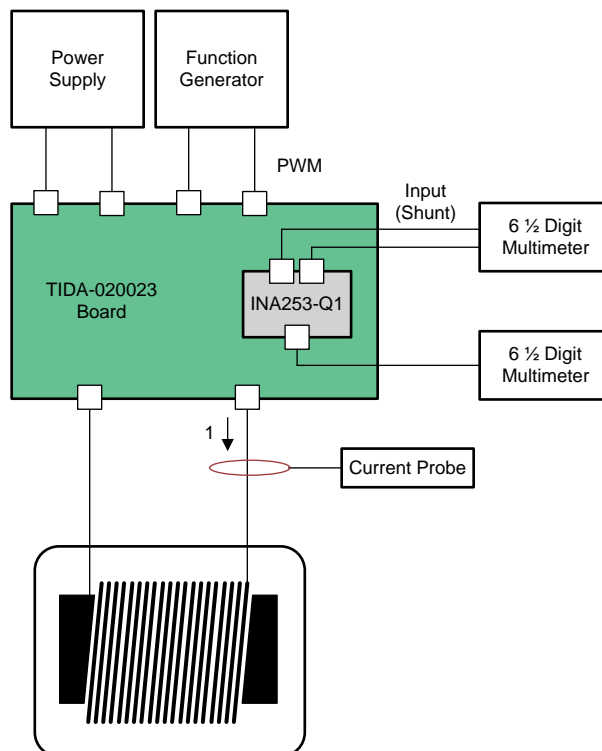
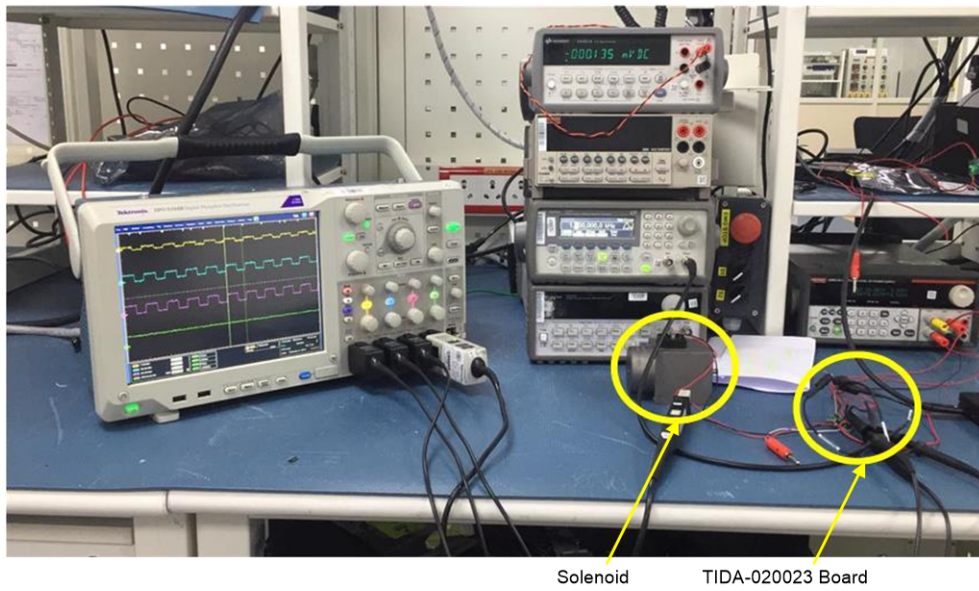

## 3.2 Testing and Results

### 3.2.1 Test Results

Proportional solenoid drive and current sense accuracy results are described in this section. The images from 图 11 to 图 14 show the functionality test results. For this test 图 8 setup is used. 图 11 and 图 12 show that as the duty cycle changes, output current which flows through the solenoid changes. With the use of **TLV1805-Q1 possibility of larger duty cycles from 1 to 99%** is shown in the below cases. faster response times and larger duty cycle percentage can be achieved.

图 11 and 图 12 oscilloscope channels are defined as

- Channel 1: Duty cycle input
- Channel 2: Output of the TLV1805 device or voltage at the MOSFET gate terminal
- Channel 3: Voltage at the source terminal of the MOSFET
- Channel 4: Current flowing through the solenoid

图 11. Changes in Output Current Based on Duty Cycle(1% to 45%) Change



图 12. Changes in Output Current Based on Duty Cycle (45% to 99%) Change



图 13 和 图 14 显示 INA253-Q1 器件的输出电流与流经螺线管的电流成正比。

示波器通道定义为：

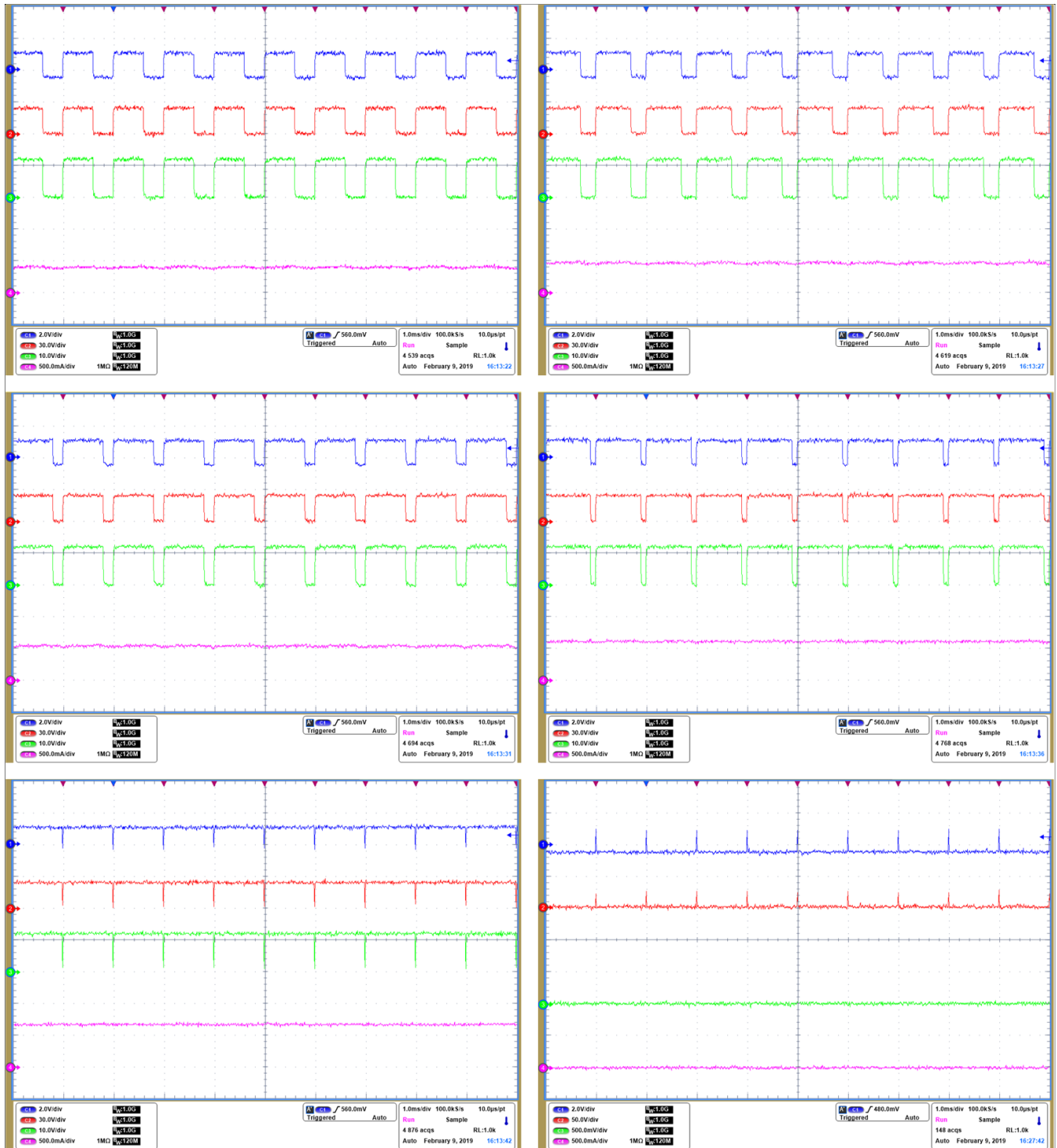
- Channel 1: Duty cycle input

- Channel 2: Output of the TLV1805 or voltage at the MOSFET gate terminal
- Channel 3: INA253 output
- Channel 4: Current flowing through the solenoid

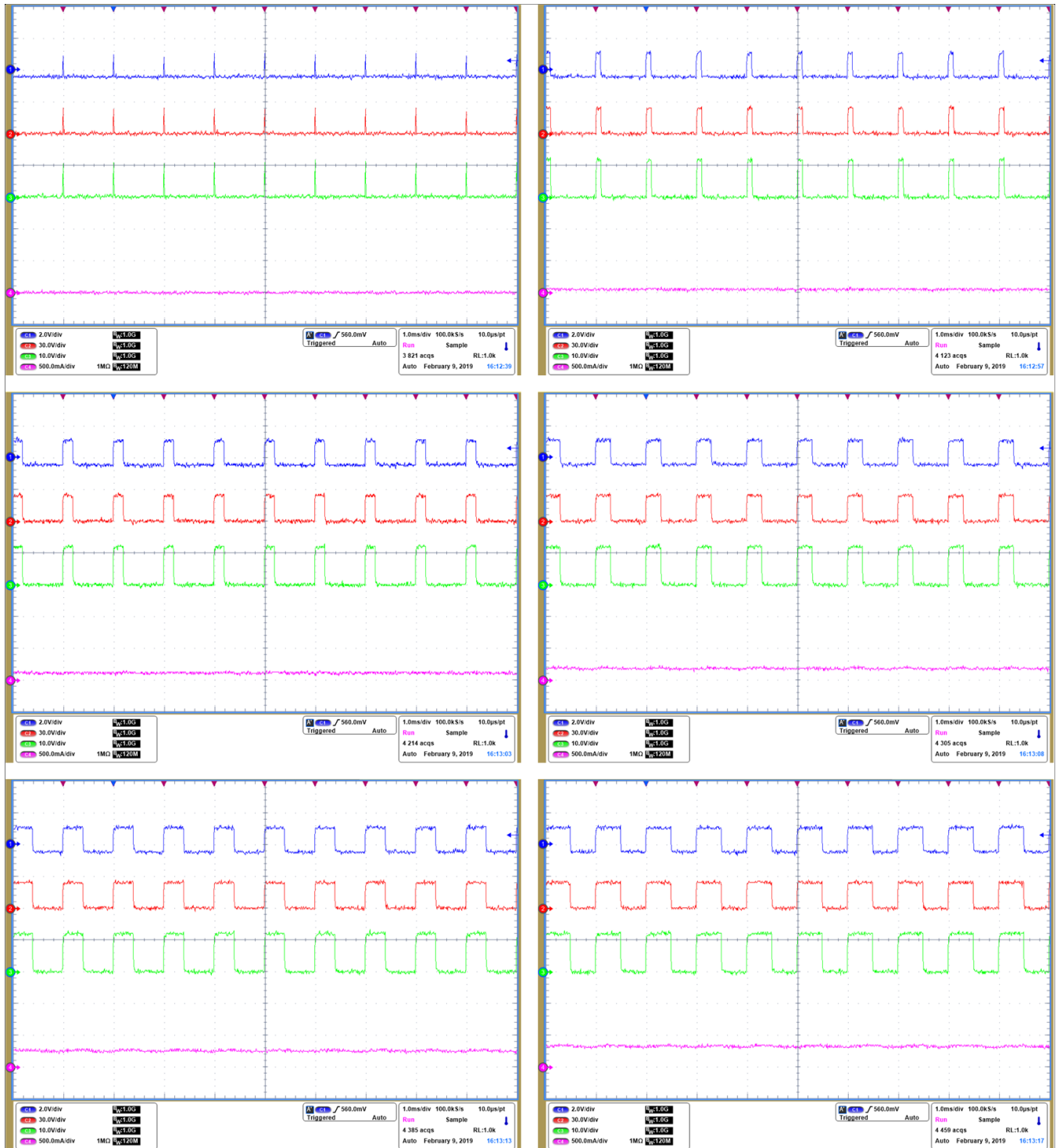
**图 13. Changes in Output Current and INA253-Q1 Output Voltage Based on Duty Cycle(1% to 45%) Change**





图 14. Changes in Output Current and INA253-Q1 Output Voltage, Based on Duty Cycle (45% to 99%) Change

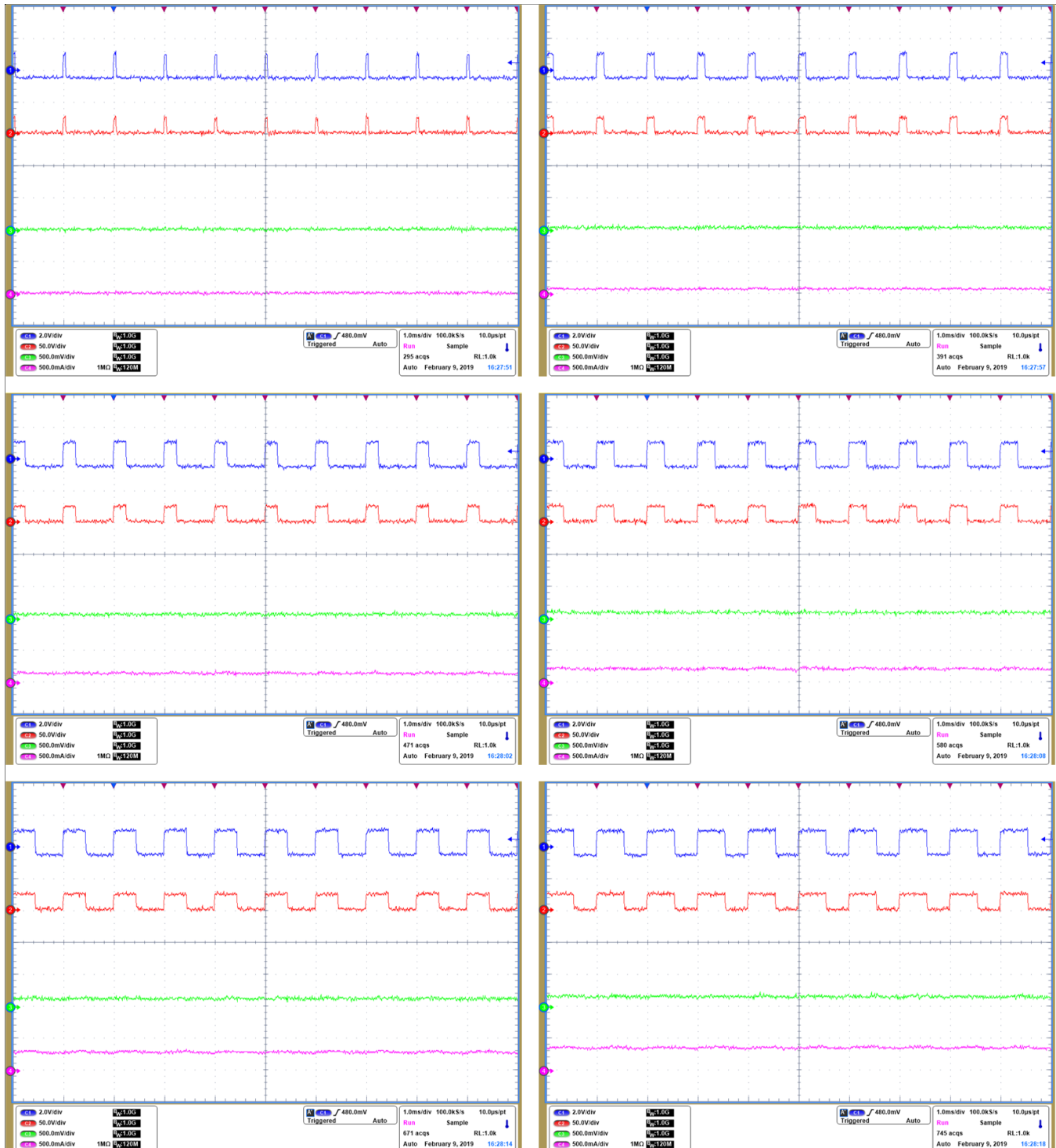
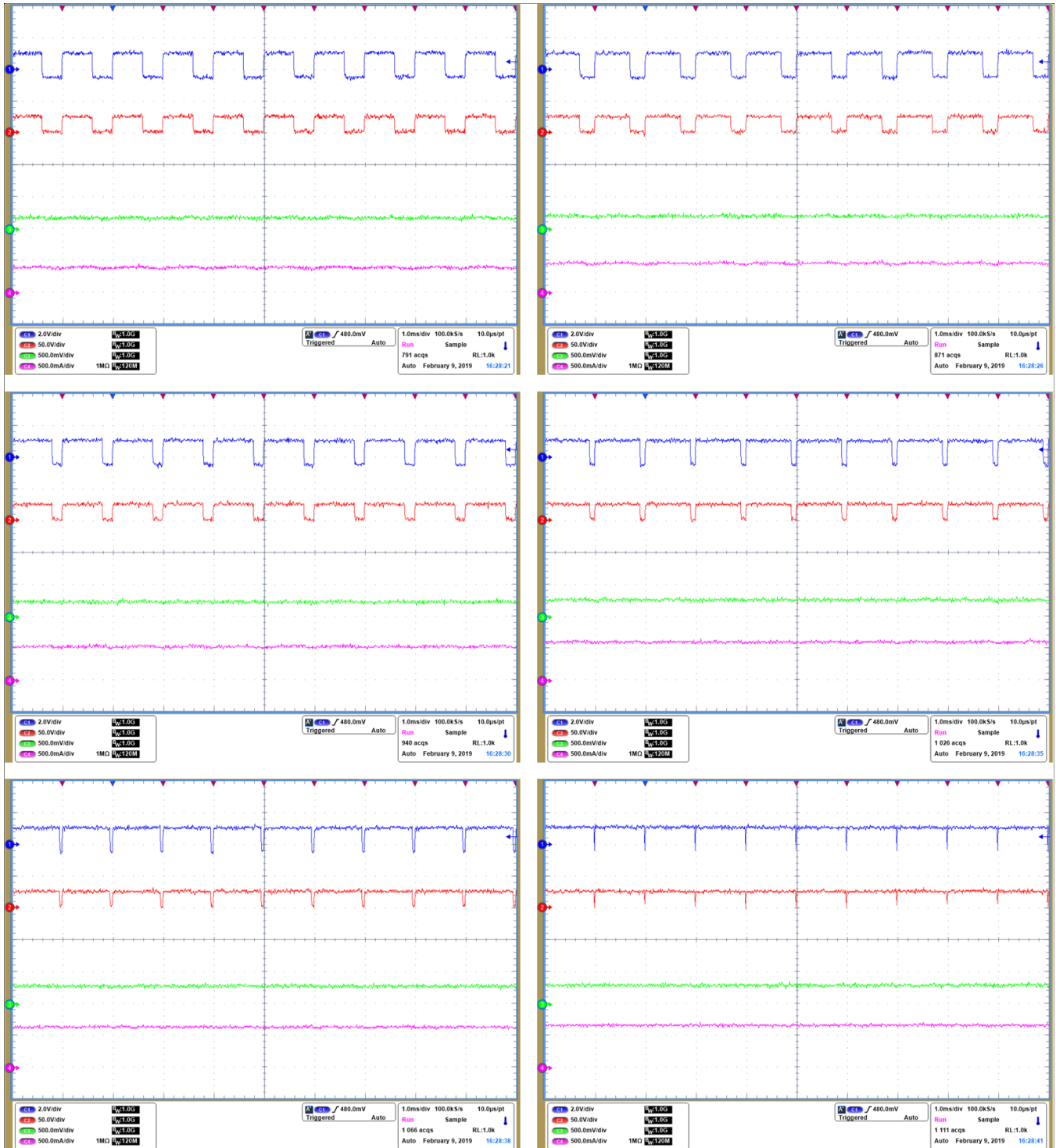

Accuracy Tests

As the previous figures show, a considerable amount of current flows through the solenoid. In the current case with the available solenoid, 670 mA of current flows through the solenoid with varied duty cycles ranging from 1 to 99%. 图 9 shows the accuracy test setup. Two multimeters are connected in such a way that one is attached to the INA253 terminals in a differential fashion another multimeter is connected to the output of INA253.

图 15 shows the accuracy plot of the INA253-Q1 device. Observe that the full-scale accuracy is around 0.5%.

图 15. Accuracy Plot

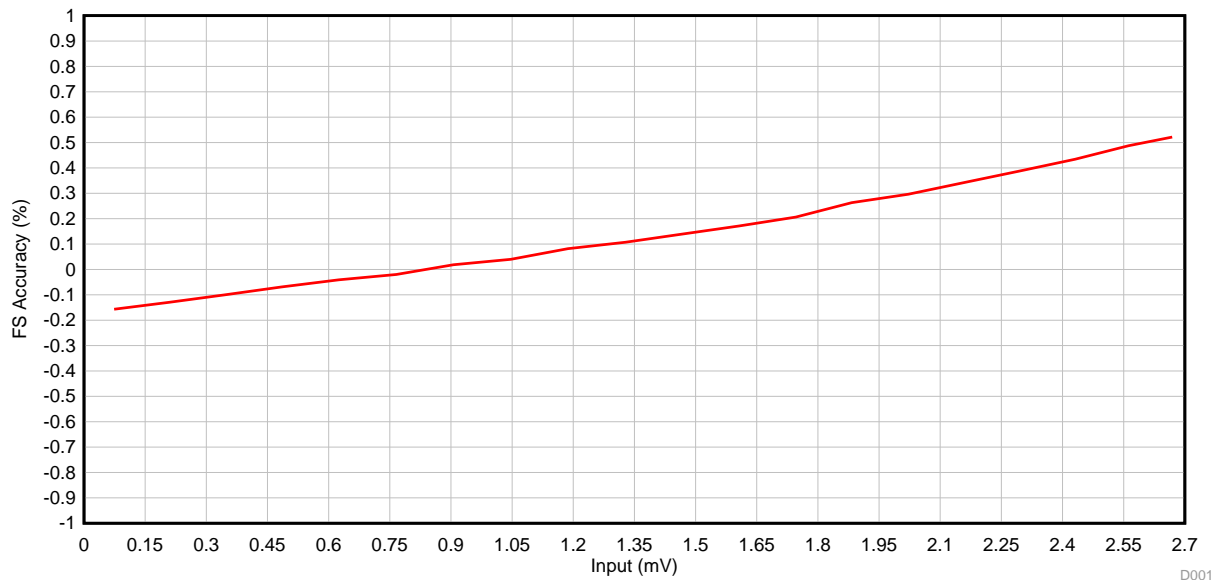

## 4 Design Files

### 4.1 Schematics

To download the schematics, see the design files at [TIDA-020023](#).

### 4.2 Bill of Materials

To download the bill of materials (BOM), see the design files at [TIDA-020023](#).

### 4.3 PCB Layout Recommendations

#### 4.3.1 Layout Prints

To download the layer plots, see the design files at [TIDA-020023](#).

### 4.4 Altium Project

To download the Altium Designer® project files, see the design files at [TIDA-020023](#).

### 4.5 Gerber Files

To download the Gerber files, see the design files at [TIDA-020023](#).

### 4.6 Assembly Drawings

To download the assembly drawings, see the design files at [TIDA-020023](#).

## 5 Software Files

To download the software files, see the design files at [TIDA-020023](#).

## 6 Related Documentation

1. Texas Instruments, [Reference Design for Automotive, Proportional-Solenoid Current Sensor Design Guide](#)
2. Texas Instruments, [High-Side Drive, High-Side Solenoid Monitor With PWM Rejection Tech Note](#)

### 6.1 商标

E2E is a trademark of Texas Instruments.  
Altium Designer is a registered trademark of Altium LLC or its affiliated companies.  
All other trademarks are the property of their respective owners.

### 6.2 Third-Party Products Disclaimer

TI'S PUBLICATION OF INFORMATION REGARDING THIRD-PARTY PRODUCTS OR SERVICES DOES NOT CONSTITUTE AN ENDORSEMENT REGARDING THE SUITABILITY OF SUCH PRODUCTS OR SERVICES OR A WARRANTY, REPRESENTATION OR ENDORSEMENT OF SUCH PRODUCTS OR SERVICES, EITHER ALONE OR IN COMBINATION WITH ANY TI PRODUCT OR SERVICE.

## 7 About the Author

**SANDEEP TALLADA** is a systems engineer at Texas Instruments. As a member of the Automotive Systems Engineering team, Sandeep focuses on HEV, EV, powertrain end-equipments and creating subsystem reference designs. He brings to this role experience in sensor systems technology. Sandeep earned his master of science in sensor systems technology from the University of Applied Sciences Karlsruhe, Germany.

## 修订历史记录

注：之前版本的页码可能与当前版本有所不同。

### Changes from Original (April 2019) to A Revision

### Page

- 
- 已删除 删除了功能方框图中的分立式电荷泵。向功能方框图中添加了 PWM 输入。同样适用于图 1 中的功能方框图。 .... 1
  - 电路板照片中包含了物体，用于尺寸参考。 .... 1
-

## 重要声明和免责声明

TI“按原样”提供技术和可靠性数据（包括数据表）、设计资源（包括参考设计）、应用或其他设计建议、网络工具、安全信息和其他资源，不保证没有瑕疵且不做任何明示或暗示的担保，包括但不限于对适销性、某特定用途方面的适用性或不侵犯任何第三方知识产权的暗示担保。

这些资源可供使用 TI 产品进行设计的熟练开发人员使用。您将自行承担以下全部责任：(1) 针对您的应用选择合适的 TI 产品，(2) 设计、验证并测试您的应用，(3) 确保您的应用满足相应标准以及任何其他功能安全、信息安全、监管或其他要求。

这些资源如有变更，恕不另行通知。TI 授权您仅可将这些资源用于研发本资源所述的 TI 产品的应用。严禁对这些资源进行其他复制或展示。您无权使用任何其他 TI 知识产权或任何第三方知识产权。您应全额赔偿因在这些资源的使用中对 TI 及其代表造成的任何索赔、损害、成本、损失和债务，TI 对此概不负责。

TI 提供的产品受 [TI 的销售条款](#) 或 [ti.com](#) 上其他适用条款/TI 产品随附的其他适用条款的约束。TI 提供这些资源并不会扩展或以其他方式更改 TI 针对 TI 产品发布的适用的担保或担保免责声明。

TI 反对并拒绝您可能提出的任何其他或不同的条款。

邮寄地址：Texas Instruments, Post Office Box 655303, Dallas, Texas 75265

Copyright © 2022，德州仪器 (TI) 公司