

ADS528x 评估板用户手册

用户手册

内容

1	概述	4
	1.1 目的	4
	1.2 评估板基本功能	5
	1.3 ADS528x 评估板快速启动程序	6
2	电路描述	7
	2.1 原理图	7
	2.2 电路功能模块	7
3	TI公司模数转换器串行外围接口控制接口	9
	3.1 安装模数转换器串行外围接口控制软件	9
	3.2 利用TI公司模数转换器串行外围接口软件	9
4	模数转换器评价	12
	4.1 选择硬件	12
	4.2 选择相关的输入频率	13
5	勘误表	14
	5.1 印刷电路勘误表	14
6	物理描述	15
	6.1 印刷电路板布局	15
	6.2 材料清单	19
	6.3 印刷电路板图	22
	重要的注释	27

图表

1	ADS5281评估板	5
2	TI公司模数转换器串行外围接口控制接	9
3	顶层印刷层	15
4	地线层	16
5	电源层	17
6	底层的印刷层	18
7	评估板原理图1	22
8	评估板原理图2	23
9	评估板原理图3	24
10	评估板原理图4	25
11	评估板原理图5	26

表列表

1	三个跳线表	6
2	评估板的供电电源选择	7
3	ADS528X 经常使用的寄存器	11
4	材料清单	19

1 概述

本用户指南主要描述了ADS5281/82/87 (ADS528X) QFN芯片评估板的整体情况，并且给出了评估板的一般特征和主要功能。图1是评估板的图片。

1.1 目的

评估板提供了一个测试平台，主要是测试8通道的ADS528X模数转换器在各种信号、参考电压和供电条件下性能，本指导书还包含了评估板的原理图。ADS5281和DS5282 芯片是12位模数转换器，而ADS5287芯片是10位模数转换器。



图1. ADS5281 评估板

1.2 评估板基本功能

通过外部SMA连接器，给模数转换器提供8个模拟输入。

评估板给模数转换器（ADC）时钟，提供了一个外部SMAC接口，ADC的时钟电路连接单端信号或差分时钟信号，评估板上允许用户利用单端时钟信号和差分变压器耦合时钟从而评估ADC。

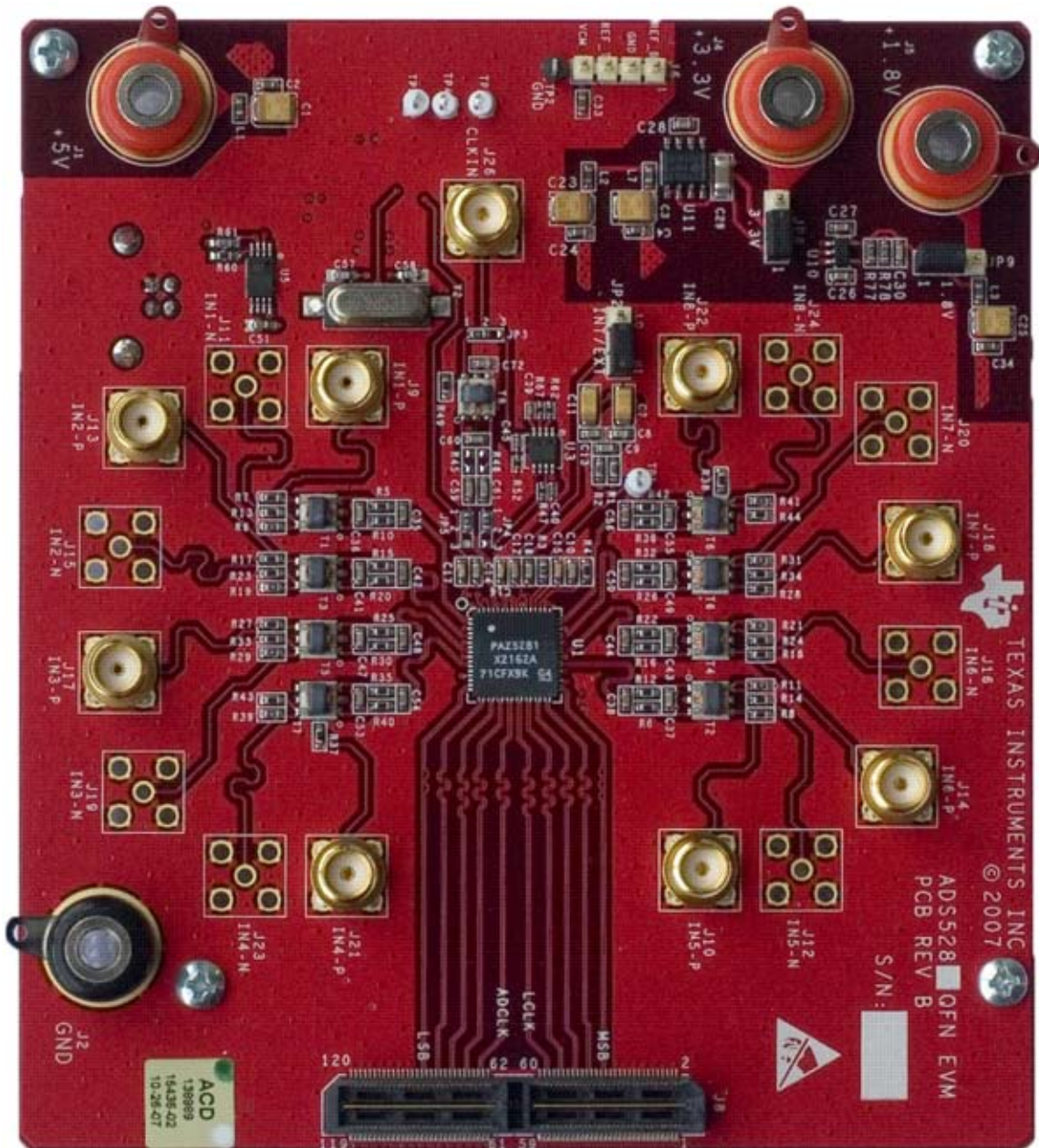
评估板数字信号的输出是通过一个高速、高密度同步输出口，数字信号输出接口是直接连接TSW1200 Rev B或者通过一个适配器连接到ADSDer-50评估板上，这两种连接方式，都可以把串行数据转换为并行CMOS数据。

电源通过一个橡胶插头座，与评估板连接。分别采用单独插座，给ADC的模拟部分、数字部分和辅助电路供电。

1.3 ADS528x 评估板快速启动程序

评估板提供了灵活的评估方法，可以在各种模式下运行。一个基本安装程序，被用来检查电路板初始状态，其步骤如下：

1. 对照列表1确定所有跳线位置正确

表1. 三个跳线放置列表

JUMPER	FUNCTION	LOCATION: PINS 1-2	LOCATION: PINS 2-3	DEFAULT
JP2	ADC internal or external reference selection	ADC internal reference	ADC external reference	1-2
JP3 (SMT)	EVM clock input selection	Transformer coupled	Single-ended PECL	1-2
JP4 (SMT)	ADC CLKP	Transformer	Single-ended PECL	1-2
JP5 (SMT)	ADC CLKM	Transformer	GND	1-2
JP8	Selects power management configuration	ADC powered by LDO (3.3 V)	ADC powered by J4 (3.3 V)	1-2
JP9	Selects power management configuration	ADC powered by LDO (1.8 V)	ADC powered by J5 (1.8 V)	1-2

2. 使J1连接5V电源供电并返回给J2
3. 开关电源处于开启状态
4. 利用输出50W的信号发生器，给J26输入0V偏差，1.5Vpp的正弦时钟。时钟频率必须满足芯片规格的要求。
5. 利用输出50W的频率发射器，给J9提供5-MHz，0V偏差，-1-dBFS振幅的正弦信号，给ADC提供变压器耦合的差分输入信号。
6. 连接USB揽线，打开PC软件，并且提供复位命令。第一次使用时，可以参考3.1部分进行初始化配置。
7. 为了利用逻辑分析器评价ADC的数字数据，把J8连接到ADS5281DeSerAdapter+ADSDeser-50EVM或TSW1200串并转换卡上。

注释： 软件操作：为了正确地进行操作，用户必须利用附带的软件去复位。在数据手册中，除了提供详细的初始化寄存器的写操作外，附带的软件也设置模数转换器引脚ADCRESET和PD的状态，不正确的操作会引起初始化失败。

2 电路描述

2.1 原理图

在6.3部分提供了评估板的原理图。

2.2 电路功能

下面这一部分主要描述了各个部分电路的功能，可以参考相关的数据手册来进行操作。

2.2.1 供电电源

通过一个橡胶插座，给评估板进行供电。在默认的状态下，评估板是通过电源管理器给模数转换器、模拟和数字部分供电，也可以通过单独5V电源供电。模数转换器电源管理部分，一般是基于TPS77533和TPS73218芯片的，这两个芯片各自提供3.3 V和1.8 V电压，另外，评估板具有单独给ADC的模拟部分提供3.3V、数字电路提供1.8V供电能力。电路板只是采用了唯一地线层，为了散热，散热块与具有多个通孔的地线层连接。表2给提供了各种供电选项。

表2. 评估板EVM供电选项

EVM Banana Jack	DESCRIPTION
J1	Auxiliary circuit 5-V digital supply: PECL driver and USB circuitry
J2	Single ground plane
J4	ADS528x 3.3-V analog supply (only active when JP8 = 2–3)
J5	ADS528x 1.8-V digital supply (only active when JP9 = 2–3)

2.2.2 输入时钟

给J26引脚输入单端方形或正弦时钟信号，时钟频率不应该超过数据手册上的最大值。不同的时钟频率的选项，为评价模数转换器提供了灵活性。

在默认的情况下，单端时钟信号通过一个TC1-1T转换器转换为差分时钟信号，当采用这种方式时，模数转换器应该配置成差分时钟，也就是给寄存器地址0x42写上0x8001值。如果选择默认状态，在经过软件复位之后，这个选项的设置和EVM评估板的默认设置是一样的。

第二个评估板EVM的选择是允许模数转换器配置成单端模式。这样通过利用半导体放大器MC100EPT21给模数转换器提供单端信号，这个芯片主要是把正弦波转换成方形波。在ADS528X和ADS527X芯片上使用了这种配置。为了采用这种模式，把接口JP3、JP4和JP5位置2–3短路即可。

2.2.3 外部参考电压

评估板给模数转换器，提供了一个强制性的外部参考电压。在默认情况下，模数转换器被配置为利用模数转换器内部产生的参考电压供电。为了强制模数转换器利用外部参考电压，需要短路JP2焊锡的2–3位置，这样就把模数转换器的INT/EXT引脚连接地线了，然后，给J6引脚1连接电压REFB，引脚3连接REFT电压，引脚2连接地线GND。

电路描述

2.2.4 模拟输入

评估板提供了8个模拟输入，ADC8个通道中的每一个通道，都利用SMA连接器进行连接。SMA输入通道是J9、J10、J13、J14、J17、J18、J21和J22，在默认情况下，模数转换器接收单端输入信号，并且利用小型电路的TC1-1T转换器把单端信号转变成一个差分信号，模数转换器输入是有偏移的直流信号，这个直流信号是通过模数转换器中的直流电机，在变换中心次线圈上，通过电压变换得来的。在评估板上也允许提供差分输入，目的是在每一个通道上使用两个SMAs转换器。

2.2.5 数字输出

串行的低压差分信号数字输出可以通过J8输出接口来访问。评估板被设计成具有TSW1200 Rev B串并转换卡接口，可以和J8直接连接。另外，ADSDeSer-50EVM评估板，利用转换卡和适配器ADS5281DeSerAdapter直接连接，TSW1200 Rev B和ADSDeSer-50EVM需要连接100W的端接电阻，端接电阻必须放在接收器的末端，目的是为了得到每一个低压差分信号对。

注释： TSW1200 Rev B:要想采用TSW1200芯片作为串并转换器，需要注意的是最小化模数转换器的采样频率，可以把采样频率设置在32MHz。TSW1200芯片采用了一个数字时钟管理器，这个管理器在32MHz频率下工作。

所有关于ADSDeSer-50EVM评估板的串并转换器文档，可以在ADSDeSer-50EVM评估板用户手册SBAU091上看到，把Xilinx公司的FPGA芯片和TI公司的ADS527x系列的模数转换器相连接，参考Xilinx公司的FPGA芯片应用指导书XAPP774，VHDL串并转换器的源代码可以在Xilinx公司的网站上得到。

3 TI 模数转换器 (ADC) 串行外围接口 (SPI) 控制接口

在这一部分将要描述与ADC三线制SPI进行通信的软件，这些信息可以和芯片的数据手册联系在一起，同时这些资料还讲解了芯片的有效寄存器内容。

3.1 安装ADC SPI控制接口

ADC SPI控制接口软件，可以通过运行光盘上的setup.exe可执行文件在自己的电脑上安装，安装文件的安装用户界面需要USB驱动，USB驱动实现与评估板上USB接口进行通信。在软件安装上之后，USB线第一次连接时，可以进行USB驱动的安装。当提示时，用户应该允许Windows™操作系统自动寻找设备驱动，它应该自动发现模数转换器的串行外围接口驱动。如图2所示。

注释： 第一次操作：当连接USB线和评估板第一次连接之前，需要安装附带的软件，主要是为了正确安装必需的USB驱动。如果没有安装驱动，在和评估板进行通信时，就容易出错。



图2. ADC SPI接口界面

3.2 使用的ADC SPI接口软件

一旦软件安装上了，并且接上USB线，运行软件的三个基本模式都可以使用了：SPI寄存器写操作、利用脚本文件对SPI寄存器写操作和ADS528X经常使用的寄存器的操作。

3.2.1 SPI寄存器写操作

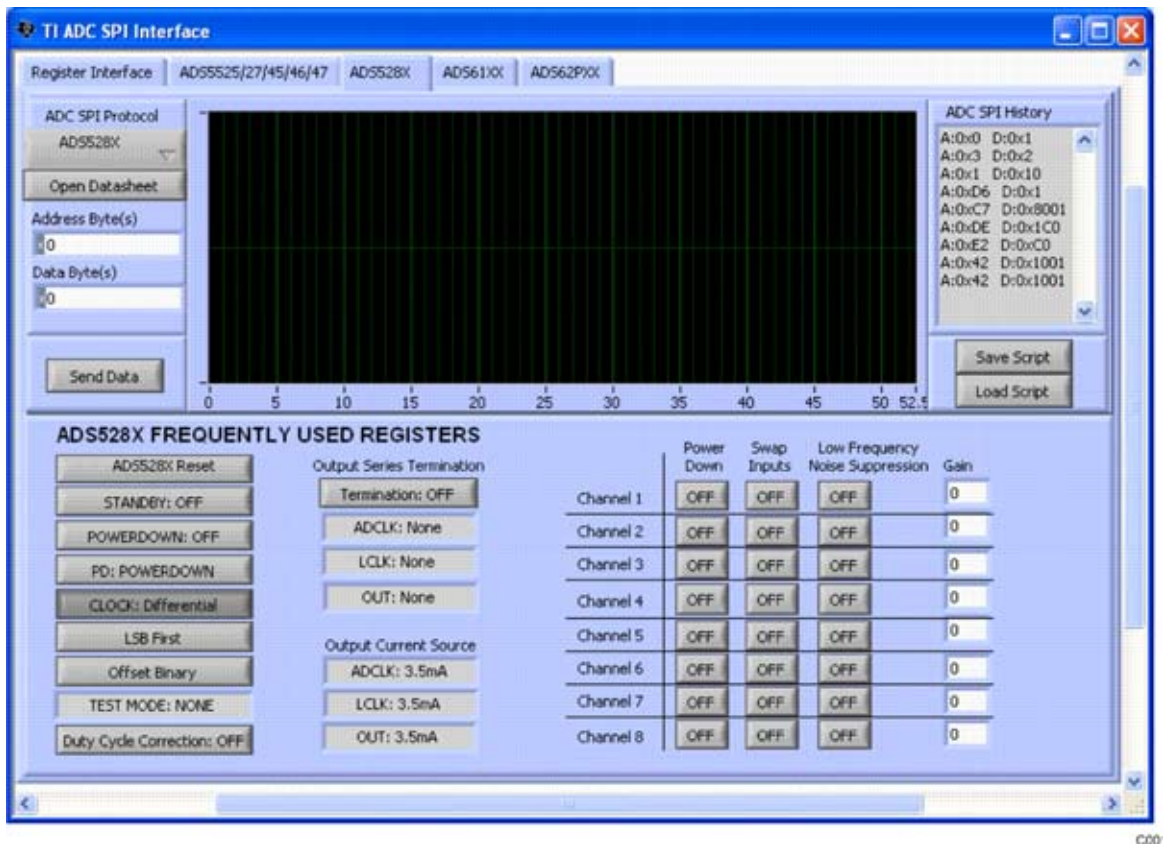
大多数基本的模式都允许对各自的寄存器地址进行写控制，在界面屏幕（图2）左上角上，从ADS528X模数转换器串行外围接口下拉列表中，选择模数转换器，接着是定义16进制的地址和数据位，这些可以从数据手册上查到。当用户准备给模数转换器发指令时，在键盘上按Enter键或单击发射数据按钮，图形指示器随着模式发给模数转换器在不断更新，对于数据和地址上的默认输入都是十六进制，主要是用小写x标识。用户可以修改默认的输入类型，可以通过单击x，定义为二进制、十进制、八进制或十六进制。多种寄存器写操作都被简化为改变地址和数据位的值，然后按回车键或单击发送数据按钮来实现。

3.2.2 利用脚本文件对SPI寄存器进行写操作

经常有多个寄存器必须被同时进行写操作，针对这种情况，可以通过利用脚本文件来标识写操作，通过单击保存脚本文件按钮进行复位，脚本文件就可以执行。通过单击下载脚本按钮，来进行更新。当准备给模数转换器写脚本文件的内容时，需要按下载文件按钮，出现寻找文件位置对话框。当用户确定了选择的文件之后，命令就发给了模数转换器。需要注意的是，当使用脚本文件时，图形提示和所有常用的寄存器按钮是不允许使用的。

相反，通过文本编辑器，可以很容易编写包含所有模数转换器寄存器写操作在内的脚本文件，一个含有例子的脚本文件在\\Install Directory\ADC SPI Control\Script Files\ADS5281_Init.reg_ADS528X下，想利用它们写自己脚本文件的用户，可以从利用ADS5281_Init.reg_ADS528X作为模板文件开始，当手写脚本文件时，需要确保在最后寄存器写操作时，没有回车操作。

3.2.2.1 ADS528X 经常采用的寄存器

为了使用起来方便，好几个按钮被综合成一个单击寄存器写操作。可以从表3中看到一般经常使用的功能按钮，这些按钮表示了ADS528X芯片上可以得到功能的子集。可以从ADS528X芯片的Tab上找到按钮，这些命令具体针对ADS528X模数转换器，当按钮被单击时，相当于软件对模数转换器进行了地址和数据同时进行写操作，当ADS528X复位键被单击时，触发了软件对模数转换器进行复位。为了和模数转换器中的内容进行匹配，需要重新设置按钮的值。当有一个按钮被按下时，图形指示就显示出SPI对ADC进行写操作。

表3. ADS528X经常采用的寄存器

Default Value	Alternate Value	Description
ADS528X Reset		Issues a software reset and also sends the initialization routine outlined in the data sheet. Furthermore, the clock is set to differential, which matches the default EVM configuration. A Reset should take place before any evaluation is done.
Standby: Off	Standby: On	Toggles the ADC standby.
Powerdown: Off	Powerdown: On	Toggles the ADC power down.
PD: Powerdown	PD: Standby	Assigns the ADS528X PD pin either a power-down or standby function.
Clock: Standby	Clock: Differential	Sets the ADC to accept either a single-ended or a differential clock. By default the ADS528X EVM is configured for a differential clock.
LSB first	MSB first	Toggles the ADC output format.
Testmode: None	Output = Ramp, Output = Deskew, Output = Synch	Sets the ADC to ignore the analog input and to apply a test pattern on the digital output.
Duty Cycle Correction: Off	Duty Cycle Correction: On	Toggles the duty-cycle correction feature.
Termination: Off	Termination: On	Enables the ability to provide a series source termination on the output signals.
ADCLK: None	ADCLK: 260, 150, 94, 125, 80, 66, 55 Ω	Changes the value of the source termination on ADCLK. Note that Termination must be On for values to take effect.
LCLK: None	LCLK: 260, 150, 94, 125, 80, 66, 55 Ω	Changes the value of the source termination on LCLK. Note that Termination must be On for values to take effect.
OUT: None	OUT: 260, 150, 94, 125, 80, 66, 55 Ω	Changes the value of the source termination on the outputs. Note that Termination must be On for values to take effect.
ADCLK: 3.5 mA	ADCLK: 0.5–7.5 mA	Changes the output source current on ADCLK.
LCLK: 3.5 mA	LCLK: 0.5–7.5 mA	Changes the output source current on LCLK.
OUT: 3.5 mA	OUT: 0.5–7.5 mA	Changes the output source current on OUT.
Power Down: Off (per channel control)	Power Down: On (per channel control)	On an individual-channel basis, allows the user to toggle power down.
Swap Inputs: Off (per channel control)	Swap Inputs: On (per channel control)	On an individual-channel basis, allows the user to toggle power down.
Low-Frequency Noise Suppression: Off (per channel control)	Low-Frequency Noise Suppression: On (per channel control)	On an individual-channel basis, allows the user to toggle the low-frequency noise-suppression mode.
Gain = 0 dB–12 dB (per channel control)	Gain = 0 dB–12 dB (per channel control)	On an individual-channel basis, allows the user to apply gain.

4 ADC的评价

这一部分描述了如何设置典型的ADC评估系统，这个评估系统类似于TI公司为了形成数据手册，而进行的测试一样。因此，这一部分的信息在本质上具有普遍性，并且可以使用在高速高分辨率的ADC评价系统上。这一部分包含了信号质量分析，这和模数转换器数据手册上的特征图是类似的，比如信噪比(SNR)和无杂波动态范围(SFDR)。

4.1 选择硬件

为了在评估模式下，更好展示模数转换器的真正的性能，需要非常仔细地选择模数转换器的信号源和模数转换器时钟源。

4.1.1 模拟输入信号发生器

当选择模数转换器模拟输入信号源的质量时，需要考虑信号产生器的谐波失真和信号源的噪声品质问题。

在许多应用中，信号发生器的谐波失真性能的重要性是仅次于模数转换器的谐波失真性能，另外如果想要得到期望的ADC SFDR，需要采用滤波器，滤波器的数量可以从数据手册中查到。用户可以很容易评价它们信号发生器谐波失真情况，主要是通过连接信号发生器，直接进行光谱分析、测量输出信号功率并且和输出信号频率的整个功率进行比较。如果在评估模式下，谐波失真比ADC更糟糕，模数转换器就记录下信号发生器的性能而掩盖了ADC SFDR。为了减少这种情况的发生，需要在信号发生器输出口附加LC滤波器。

在选定信号发生器时，另一个需要考虑的重要因素是它的噪声性能。当在同样的失真性能条件和评估模式下，如果噪声比ADC的性能更差，那么就需要ADC记录下信号源的性能。噪声有两种组成：宽频带噪声和相位附近的噪声。LC滤波器增加了宽频带噪声，从而提高失真性能，然而，相位附近的噪声是不能够通过增加附加的滤波器来提高。因此，在选择模拟信号源时，重要的一点是需要参考制造商的相位噪声图和具有最好相位噪声图的信号发生器。

4.1.2 时钟信号发生器

在高性能的模数转换器评价系统建立时，同样重要的一个方面就是选择时钟源。大多数新的模数转换器，包括ADS61xx芯片，也接受正弦或方形波形的时钟输入。在选择时钟发生器时，关键是选择具有最低抖动的信号源。随着模数转换器输入频率(f_{in})的增加，这一方面日益重要，主要是因为ADC SNR评价的设置就变成设置抖动时间(t_j)，可以用下面等式来计算。

$$SNR \text{ (dBc)} = 20 \log (2\pi \times f_{in} \times t_j(\text{rms}))$$

理论上讲，具有毫秒级抖动的方形波源，对于ADC评价系统的建立是最理想的选择。然而，实际上，市场上可以买到的方形波发生器，提供的抖动测量都是在微妙级上，这对于高分辨率的ADC评价系统的建立是非常重要的。所以，大多数评估系统是建立在基于ADC内部时钟缓冲器，内部时钟缓冲器可以把正弦输入信号转换成一个低抖动的方形波。当选择一个正弦时钟源时，可以看到相位噪声对与抖动性能具有很大的影响。因此，更多的研究需要考虑是时钟产生器的相位噪声，TI公司已经研制了高精度的集成电路硅滤波器，这种滤波器可以降低信号发生器的行为噪声，同时，当建立模数转换器输入频率被评价系统时，这些滤波器成为必须的电子器件。

4.2 选择相关的输入频率

典型的ADC分析，需要用户收集时域内的数据和在频域范围内进行傅立叶变换数据的分析，一个傅利叶变换要求信号必须是连续时间内的信号，然而，当检查ADC采样的有限集时，这是不切实际的。通常从逻辑上进行分析。因此，用户采用了一个窗函数来最小化时域中的不连续性，这是在分析采样有限集时要考虑的问题。对于ADC的分析而言，窗函数具有自己的频率标识，可以让ADC的SNR和SFDR测量方法失效。

TI 公司为了让芯片能在窗函数附近进行工作，采用了相干采样概念。相关采样的中心假设是输入到模数转换器中的输入信号，并且经过仔细选择，以便于当从有限的采样集中构造连续信号时，不存在不连续时域。为了得到这个目的，输入频率必须是ADC采样率(f_s)和从逻辑分析器(N_s)得到的采样数比值的整数倍数， f_s 和 N_s 的比值是指基频(f_f)。通过两步来决定模数转换器输入频率，首先，要选择与评价ADC相关的频率，然后，把所选的频率和基本频率相除，结果值就是一个非整数的数值，因此应该被近似成为最近的奇数、素数或整数。一旦整数或频率点数(f_{bin})被决定，可以通过基本频率来放大。为了获取相干频率，主要对ADC输入信号发生器编写程序。这个过程总结如下：

$$f_f = f_s / N_s$$

$$f_{bin} = \text{Odd_round}(f_{desired} / f_f)$$

$$\text{Coherent frequency} = f_f \times f_{bin}$$

勘误表

5 勘误表

这部分主要描述了评估板Rev B的一些问题。

5.1 印刷电路勘误表

印刷电路上，在JP2处标示选择内部参考电压和外部参考电压是错误的，选择ADC内部参考电压是短路JP2上的引脚1-2，相对与印刷电路板上是HI或EXT，这在评估板上Rev. C进行了描述。

6 物理描述

这一部分主要描述了评估板上印刷电路板的布局物理特点。

6.1 PCB布局

评估板是由4层，0.062英寸厚的印刷电路板，采用了FR-4材料，通过图3—图6显示了每一层，布局的特征是具有共同的地线层，然而，可以采用分割地线层方法处理类似的布局。



图3. 顶层印刷板



K002

图4. 地线层

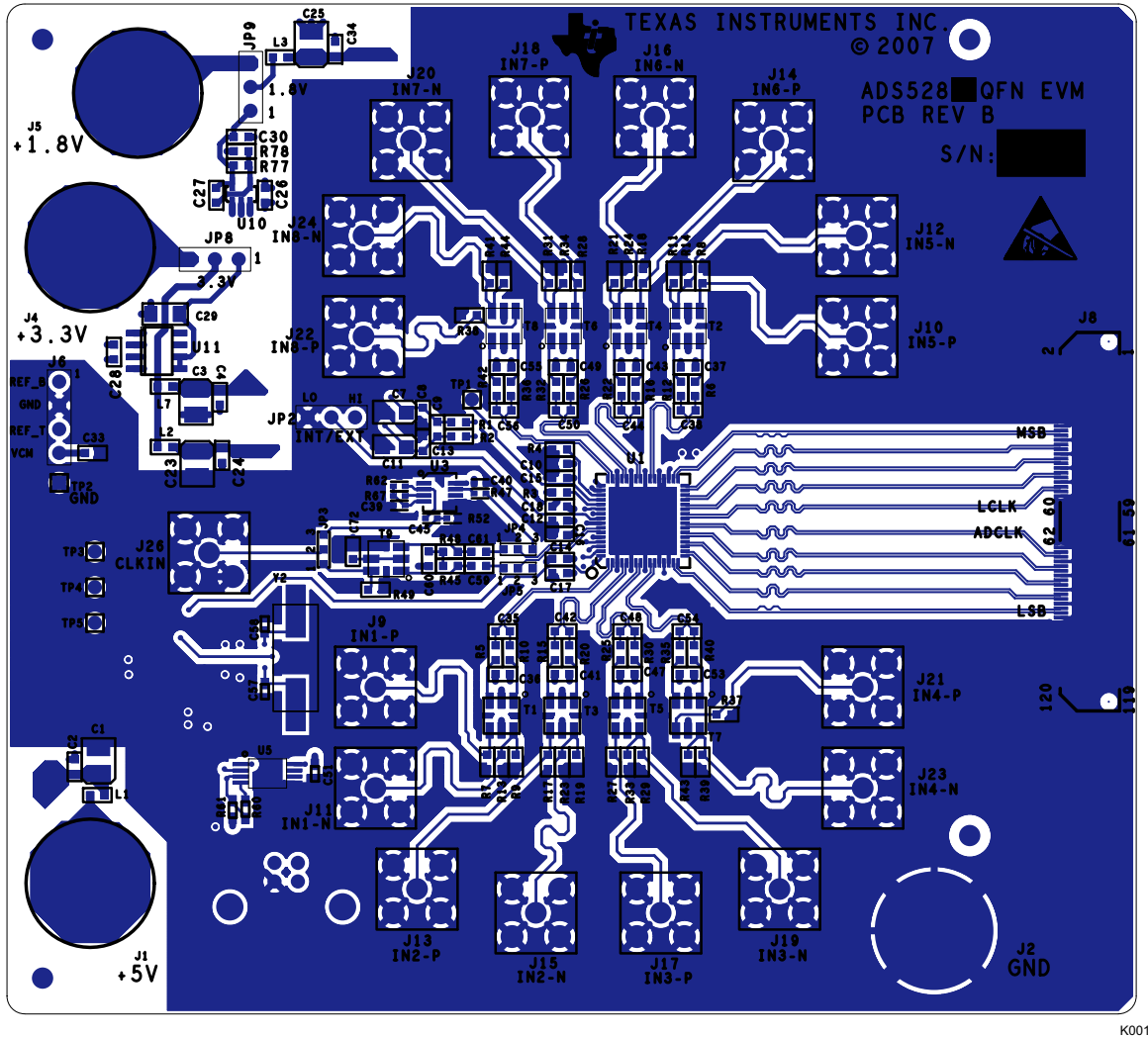
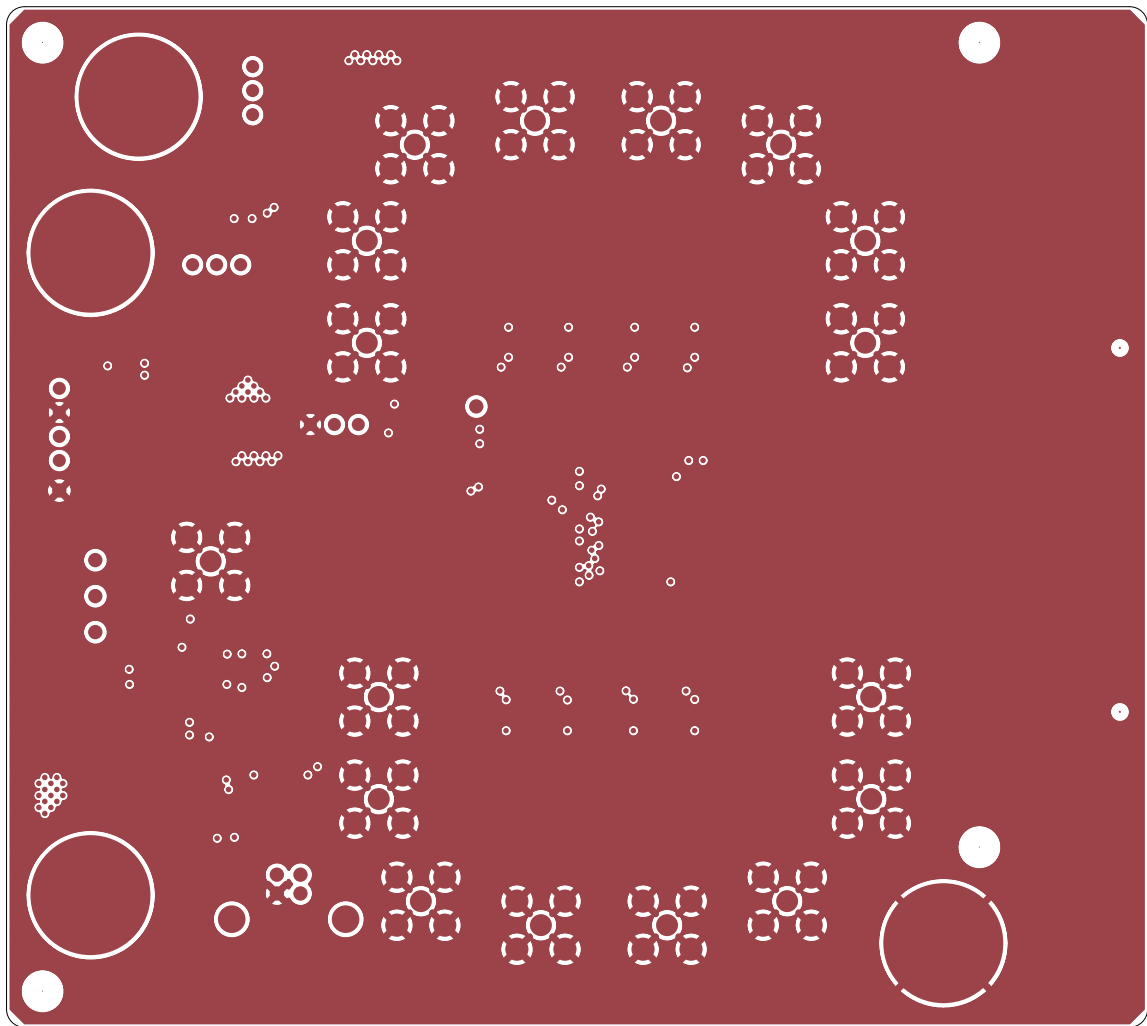
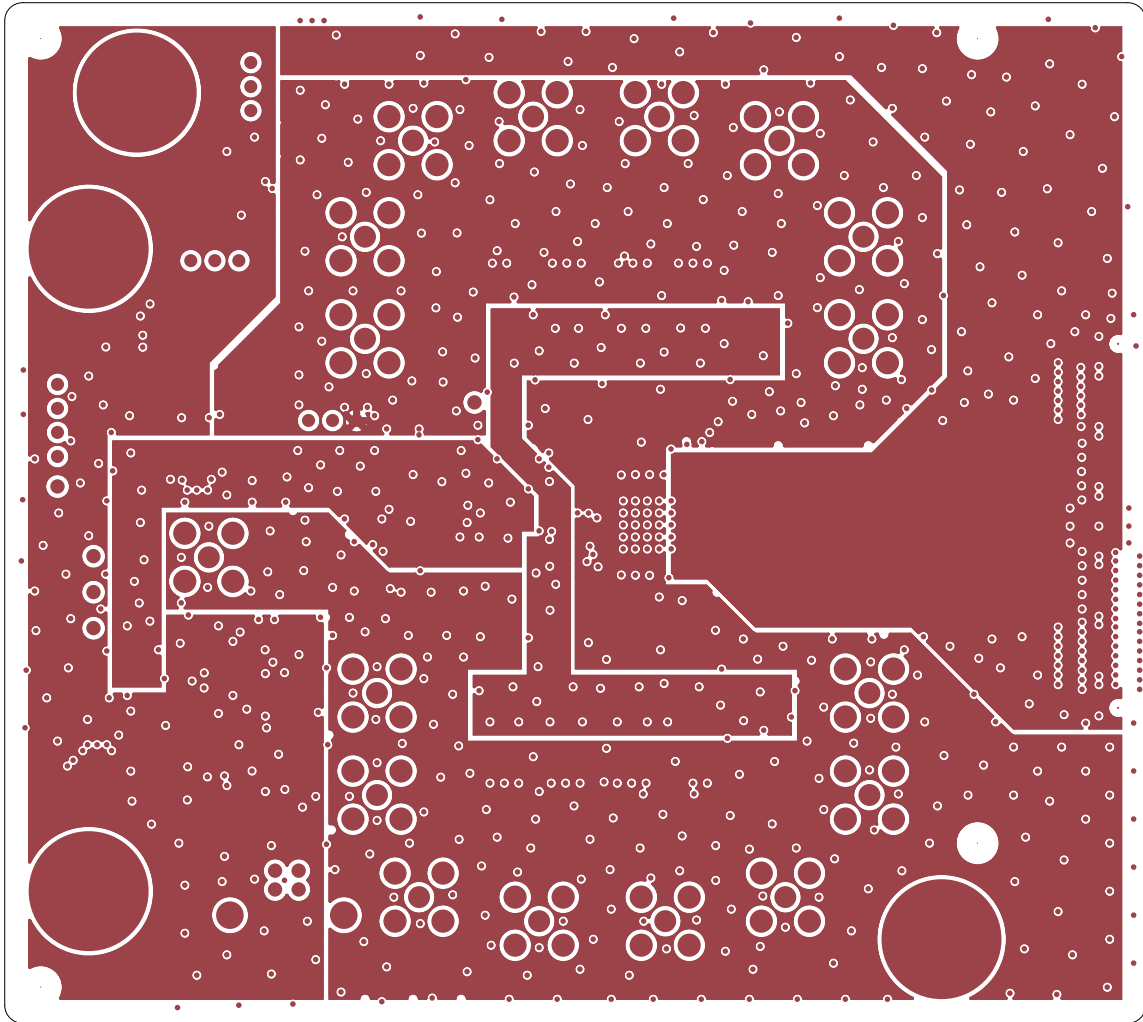

K003

图5. 电源层

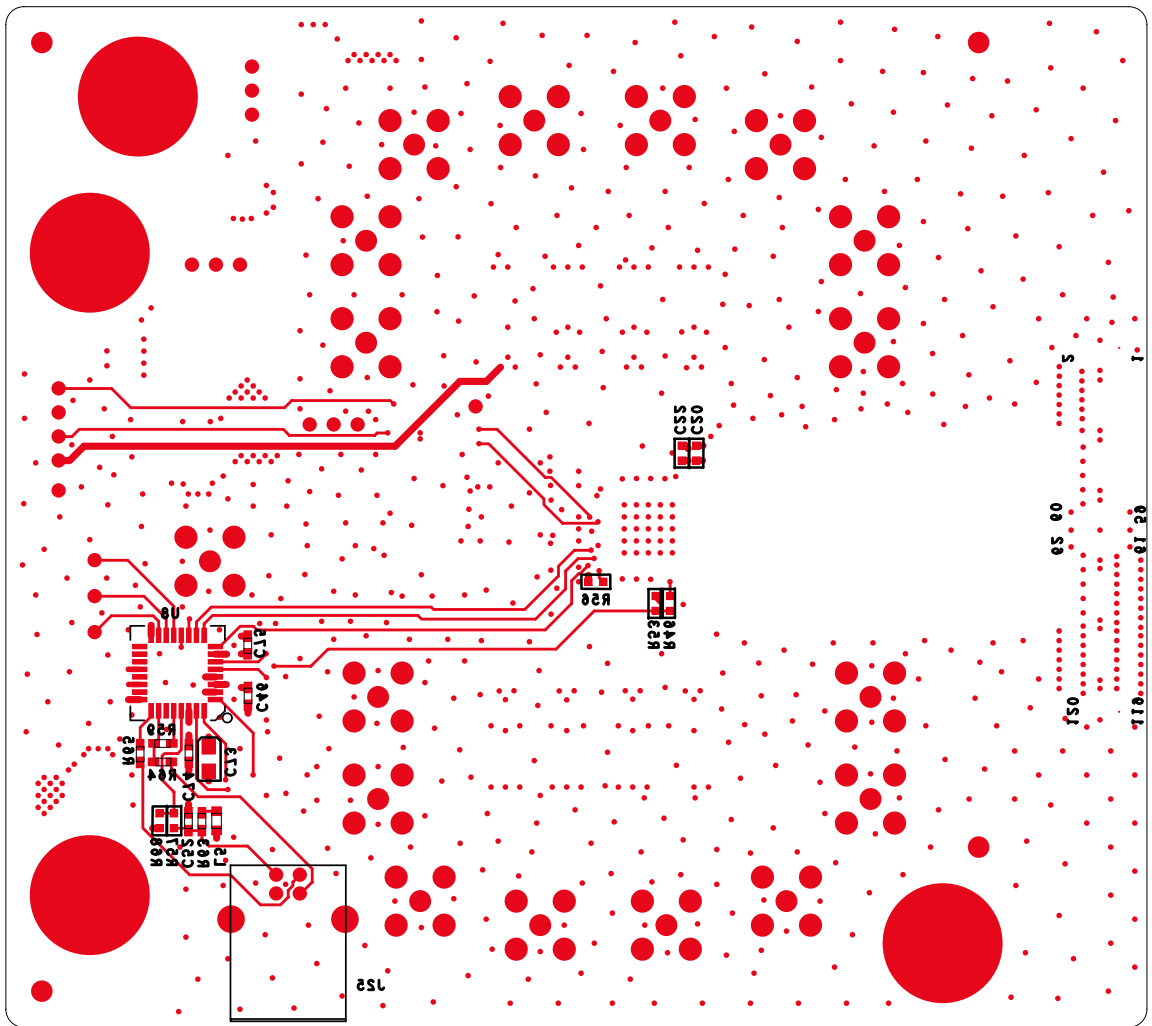

K004

图6. 底层印刷板

6.2 材料表

表4. 材料表

Reference	Not Installed	Part	Footprint	Part Number	Manufacturer	Tolerance
C1, C3, C23, C25		33 μ F	TANT_B	B45196H1336K209	Kemet	10%
C2, C4, C24, C34		1 μ F	603	ECJ-1VB0J105K	Panasonic	10%
C7, C11		22 μ F	TANT_A	B45196H1226K109	Kemet	10%
C8, C9, C10, C12, C13, C14, C18, C20, C26, C27, C28, C30, C36, C37, C41, C43, C47, C49, C53, C55, C59, C60, C61, C72		0.1 μ F	603	ECJ-1VB1C104K	Panasonic	10%
C15, C16, C17, C22		0.01 μ F	603	06035C103KAT2A	AVX	10%
C29		10 μ F	1206	ECJ-3YB1C106K	Panasonic	10%
C33		2.2 μ F	603	ECJ-1VB0J225K	Panasonic	10%
C35, C38, C42, C44, C48, C50, C54, C56		10 pF	603	ECJ-1VC1H100D	Panasonic	0.5 pF
C40, C39, C45		0.1 μ F	402	ECJ-0EB1A104K	Panasonic	10%
C46, C51, C74, C75		0.1 μ F	SMD_0603	GRM188R71H104KA93D	Murata	10%
C52		0.01 μ F	SMD_0603	C0603C103K1RACTU	Kemet	10%
C57, C58		27 pF	SMD_0603	GRM1885C2A270JA01D	Murata	5%
C73		10 μ F	TANT_A	TAJA106K016R	AVX	10%
JP2, JP8, JP9		HEADER 3POS .1 CTR				Short pins 1–2 with shunt connectors DigiKey # S9000-ND
		CONN JUMPER SHORTING		S9000-ND	DigiKey	
JP3, JP4, JP5		NO PART	SMD_BRIDGE_0603			Short pins 1–2 using 0- Ω resistors
J1, J4, J5		RED		ST-351A	ALLIED ELECTRONICS	
J2		BLK		ST-351B	ALLIED ELECTRONICS	
J6		HEADER 4	JUMPER4			
J8		QTH-060-02-F-D-A		QTH-040-01-F-D-DP-A	Samtec	
J9, J10, J13, J14, J17, J18, J21, J22, J26		SMA		142-0701-201	Johmson Components	
J11, J12, J15, J16, J19, J20, J23, J24	NOT INSTALLED	SMA		142-0701-201	Johmson Components	
J25		CONN USB TYP B FEM		897-43-004-90-000000	Milmax	

表4. 材料表 (续)

Reference	Not Installed	Part	Footprint	Part Number	Manufacturer	Tolerance
L1, L2, L3, L7		68 Ω at 100 MHz	603	MI0603J680R-10	Steward	
L5		1 k Ω at 100 MHz	SMD_0805	BLM21AG102SN 1D	Murata	
R1, R2		2 Ω	603	ERJ- 3GEYJ2R0V	Panasonic	5%
R3		0 Ω	603	ERJ- 3GEY0R00V	Panasonic	5%
R4		56.2 k Ω	603	ERJ-3EKF5622V	Panasonic	1%
R5, R6, R7, R8, R10, R12, R13, R14, R15, R16, R17, R18, R20, R22, R23, R24, R25, R26, R27, R28, R30, R32, R33, R34, R35, R36, R37, R38, R40, R42, R43, R44, R49		49.9 Ω	603	ERJ- 3EKF49R9V	Panasonic	1%
R9, R11, R19, R21, R29, R31, R39, R41		0 Ω	603	ERJ- 3GEY0R00V	Panasonic	1%
R45, R48	NOT INSTALLED	121 Ω	603	ERJ-3EKF1210V	Panasonic	1%
R46		10 Ω	603	ERJ- 3EKF10R0V	Panasonic	1%
R47, R52		49.9 Ω	402	ERJ- 2RKF49R9X	Panasonic	1%
R53, R56		10 k Ω	603	ERJ-3EKF1002V	Panasonic	1%
R57		4.7 k Ω	603	ERJ- 3GEYJ472V	Panasonic	5%
R59		1.5 k Ω	SMD_0603	ERJ-3EKF1501V	Panasonic	5%
R60		2.21 k Ω	SMD_0603	ERJ-3EKF2211V	Panasonic	1%
R61		10 k Ω	SMD_0603	ERJ- 3GEYJ103V	Panasonic	5%
R62, R67		499 Ω	402	ERJ-2RKF4990X	Panasonic	1%
R63	NOT INSTALLED	0 Ω	SMD_0603	ERJ- 3GEY0R00V	Panasonic	5%
R64, R65		26.7 Ω	SMD_0603	ERJ- 3EKF26R7V	Panasonic	1%
R68	NOT INSTALLED	10 k Ω	603	ERJ-3EKF1002V	Panasonic	1%
R77		28 k Ω	603	RC0603FR- 0728KL	Yageo	1%
R78		56.2 k Ω	603	RC0603FR- 0756K2L	Yageo	1%
TP1, TP3, TP4, TP5		T POINT R	TESTPOINT	5002	Keystone	
TP2		T POINT R	TESTPOINT	5001	Keystone	
T1, T2, T3, T4, T5, T6, T7, T8, T9		TC1-1T	XFMR_TC4-1W	TC1-1T	Mini Circuits	
U1		ADS528X_ QFN64	QFN64	ADS528X	TI	
U3		MC100EPT21		MC100EPT21DT G	On Semiconductor	

表4. 材料表 (续)

Reference	Not Installed	Part	Footprint	Part Number	Manufacturer	Tolerance
U5		93C66B	TSSOP8	93C66B-I/ST	Microchip	
U8		FT245BM	PQFN32	FT245BM	Future Technology Devices	
U10		TPS73201- SOT23	DBV5	TPS73218DBVT	TI	
U11		TPS77533D	SOIC8	TPS77533D	TI	
Y2		6.0000 MHz		ECS-60-32- 5PDN-TR	ECS	
MP2		Screw, machine, ph 4-40 × 3/8		PMS 440 0038 PH	Building Fasteners	PCB legs
MP3		Stand-off, hex, .5/4-40THR		1902C	Keystone Electronic	

物理描述

6.3 印刷电路板图

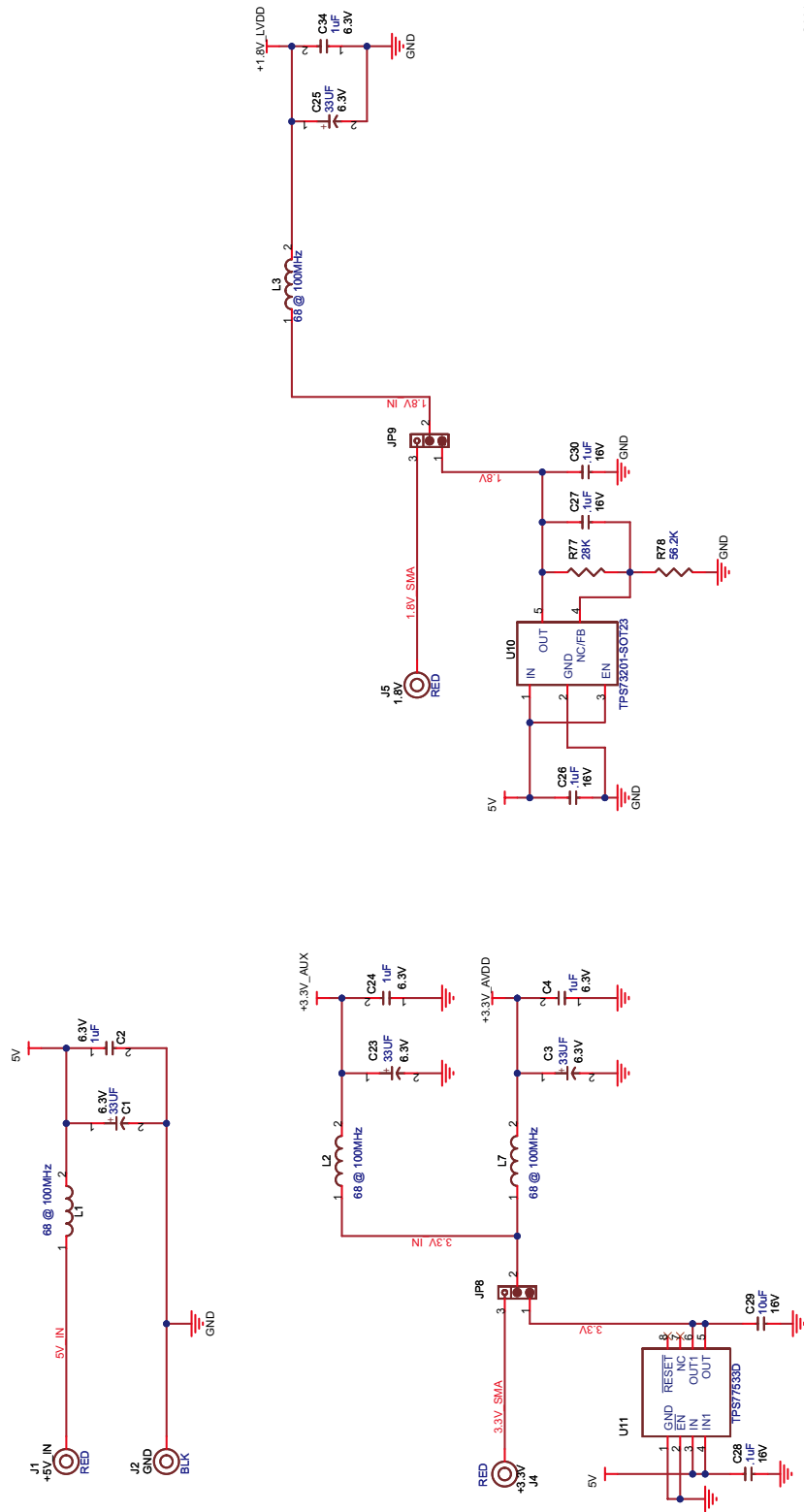

S001

图7. 评估板原理图1

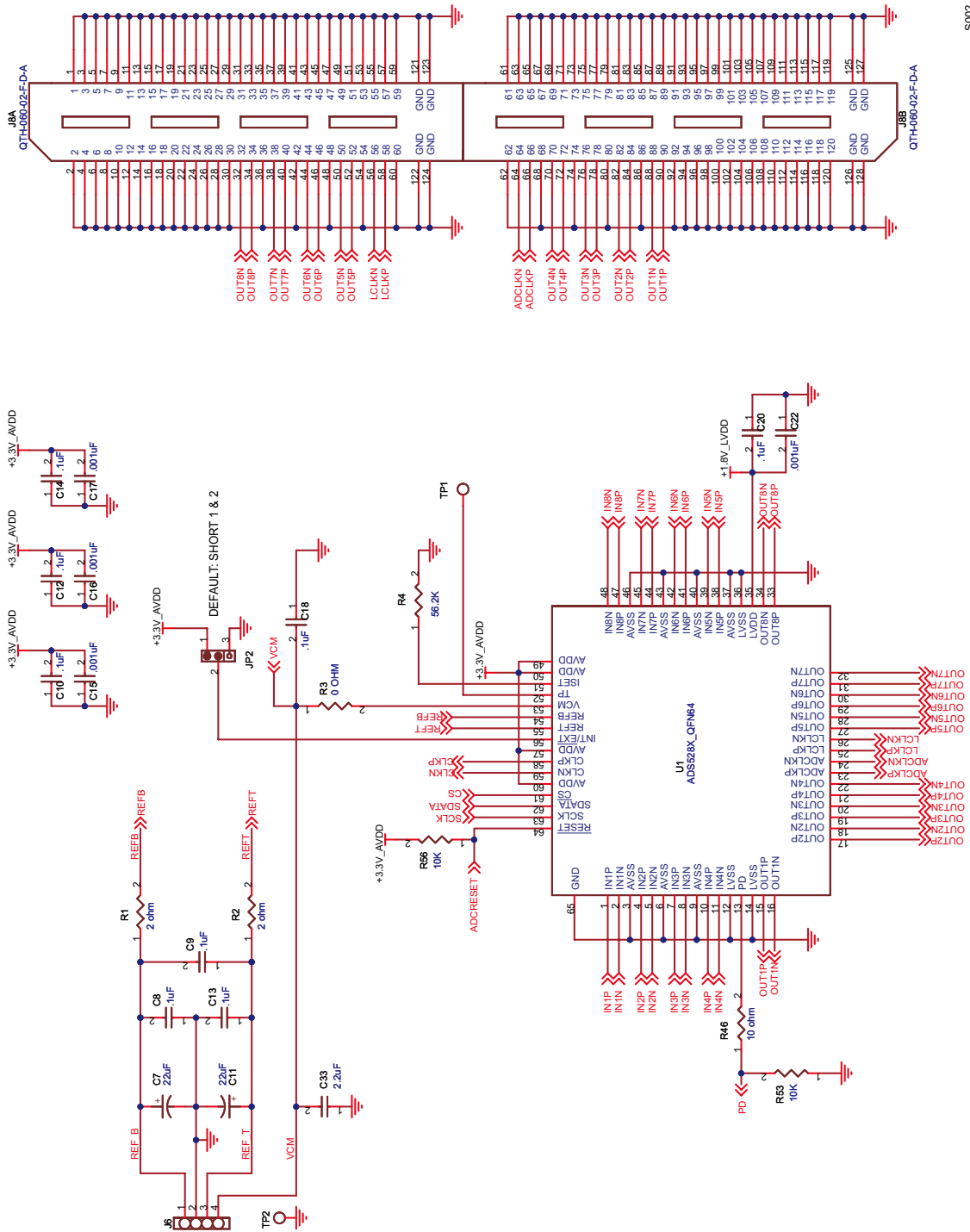

S002

图8. 评估板原理图2

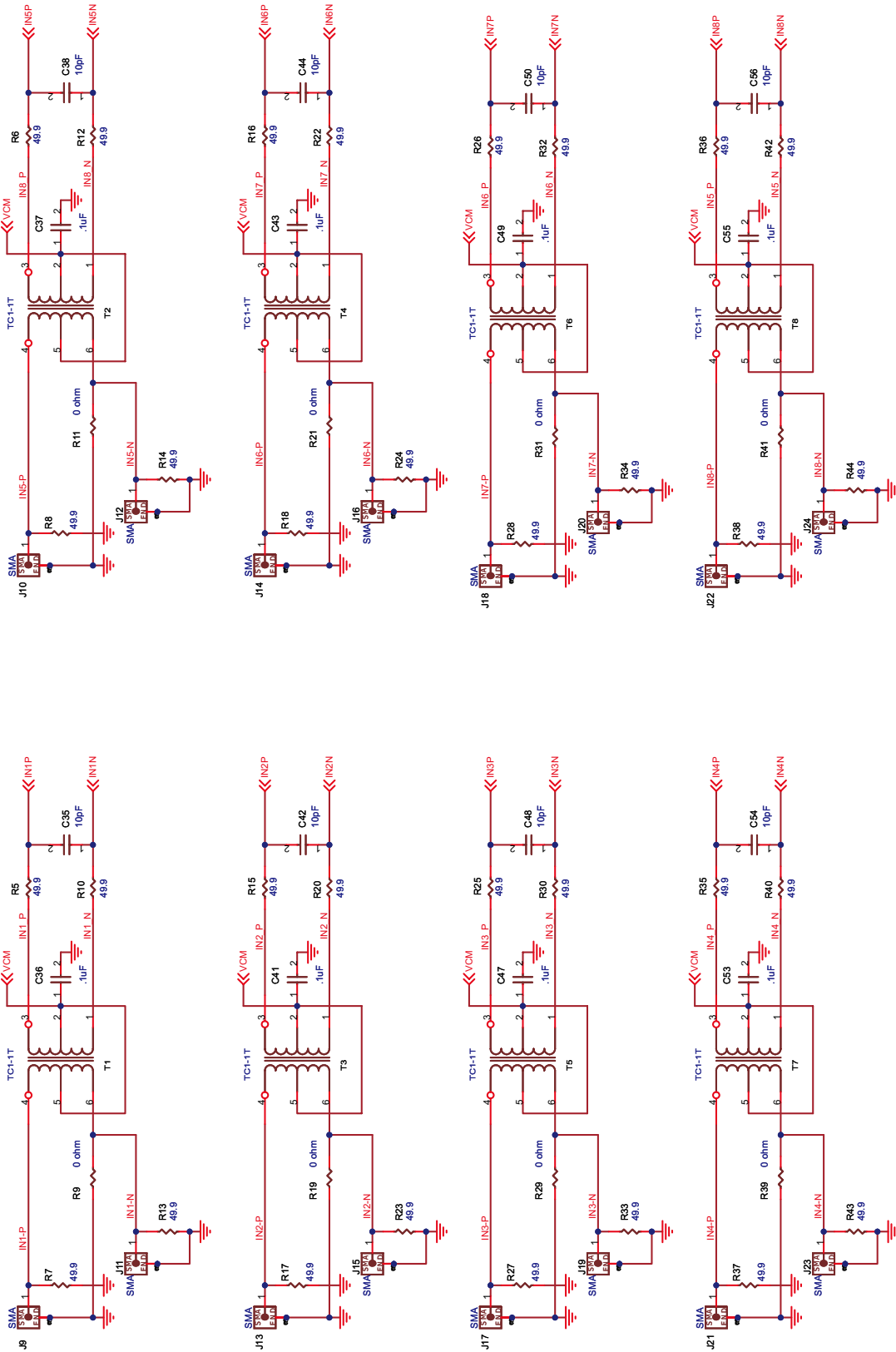

S003

图9. 评估板原理图3



图10. 评估板原理图4

EVALUATION BOARD/KIT IMPORTANT NOTICE

Texas Instruments (TI) provides the enclosed product(s) under the following conditions:

This evaluation board/kit is intended for use for **ENGINEERING DEVELOPMENT, DEMONSTRATION, OR EVALUATION PURPOSES ONLY** and is not considered by TI to be a finished end-product fit for general consumer use. Persons handling the product(s) must have electronics training and observe good engineering practice standards. As such, the goods being provided are not intended to be complete in terms of required design-, marketing-, and/or manufacturing-related protective considerations, including product safety and environmental measures typically found in end products that incorporate such semiconductor components or circuit boards. This evaluation board/kit does not fall within the scope of the European Union directives regarding electromagnetic compatibility, restricted substances (RoHS), recycling (WEEE), FCC, CE or UL, and therefore may not meet the technical requirements of these directives or other related directives.

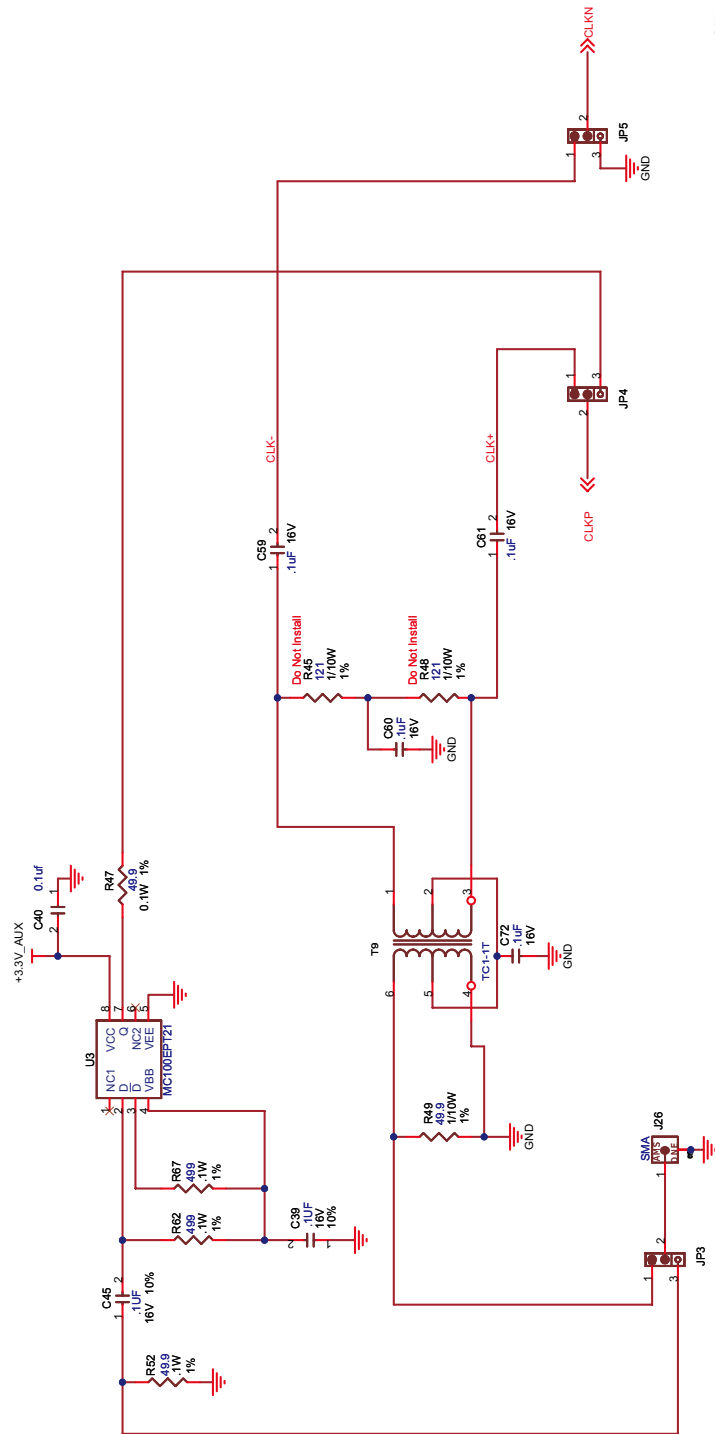
Should this evaluation board/kit not meet the specifications indicated in the User's Guide, the board/kit may be returned within 30 days from the date of delivery for a full refund. **THE FOREGOING WARRANTY IS THE EXCLUSIVE WARRANTY MADE BY SELLER TO BUYER AND IS IN LIEU OF ALL OTHER WARRANTIES, EXPRESSED, IMPLIED, OR STATUTORY, INCLUDING ANY WARRANTY OF MERCHANTABILITY OR FITNESS FOR ANY PARTICULAR PURPOSE.**

The user assumes all responsibility and liability for proper and safe handling of the goods. Further, the user indemnifies TI from all claims arising from the handling or use of the goods. Due to the open construction of the product, it is the user's responsibility to take any and all appropriate precautions with regard to electrostatic discharge.

EXCEPT TO THE EXTENT OF THE INDEMNITY SET FORTH ABOVE, NEITHER PARTY SHALL BE LIABLE TO THE OTHER FOR ANY INDIRECT, SPECIAL, INCIDENTAL, OR CONSEQUENTIAL DAMAGES.

TI currently deals with a variety of customers for products, and therefore our arrangement with the user **is not exclusive.**

TI assumes **no liability for applications assistance, customer product design, software performance, or infringement of patents or services described herein.**

Please read the User's Guide and, specifically, the Warnings and Restrictions notice in the User's Guide prior to handling the product. This notice contains important safety information about temperatures and voltages. For additional information on TI's environmental and/or safety programs, please contact the TI application engineer or visit www.ti.com/esh.

No license is granted under any patent right or other intellectual property right of TI covering or relating to any machine, process, or combination in which such TI products or services might be or are used.

FCC Warning

This evaluation board/kit is intended for use for **ENGINEERING DEVELOPMENT, DEMONSTRATION, OR EVALUATION PURPOSES ONLY** and is not considered by TI to be a finished end-product fit for general consumer use. It generates, uses, and can radiate radio frequency energy and has not been tested for compliance with the limits of computing devices pursuant to part 15 of FCC rules, which are designed to provide reasonable protection against radio frequency interference. Operation of this equipment in other environments may cause interference with radio communications, in which case the user at his own expense will be required to take whatever measures may be required to correct this interference.

EVM WARNINGS AND RESTRICTIONS

It is important to operate this EVM within the input voltage range of -3 V to 3.8 V and the output voltage range of -3 V to 3.8 V .

Exceeding the specified input range may cause unexpected operation and/or irreversible damage to the EVM. If there are questions concerning the input range, please contact a TI field representative prior to connecting the input power.

Applying loads outside of the specified output range may result in unintended operation and/or possible permanent damage to the EVM. Please consult the EVM User's Guide prior to connecting any load to the EVM output. If there is uncertainty as to the load specification, please contact a TI field representative.

During normal operation, some circuit components may have case temperatures greater than 50°C . The EVM is designed to operate properly with certain components above 25°C as long as the input and output ranges are maintained. These components include but are not limited to linear regulators, switching transistors, pass transistors, and current sense resistors. These types of devices can be identified using the EVM schematic located in the EVM User's Guide. When placing measurement probes near these devices during operation, please be aware that these devices may be very warm to the touch.

Mailing Address: Texas Instruments, Post Office Box 655303, Dallas, Texas 75265
Copyright 2008, Texas Instruments Incorporated

样片及品质信息



免费样片索取

您是否正没日没夜的忙于工作而又急需一块免费的 TI 产品样片？那就请立刻登录 TI 样片中心，马上申请吧！

数千种器件，极短的递送时间，高效的反馈速度：

- 8000多种器件及各种封装类型任君选择
- 一周 7*24 小时网上随时申请
- 两个工作日内得到反馈
- 已经有成千上万的客户通过申请样片，优质高效地完成了产品设计。

立即注册 **my.TI** 会员，申请免费样片，只需短短几天，样片将直接寄到您所指定的地址。

<http://www.ti.com.cn/freesample>

电话支持——如果您需要帮助如何选择样片器件，敬请致电中国产品信息中心 **800-820-8682** 或访问

www.ti.com.cn/support

品质保证

持续不断的专注于品质及可靠性是 TI 对客户承诺的一部分。1995 年，TI 的半导体群品质系统计划开始实施。该全面的品质系统的使用可满足并超越全球客户及业界的需求。

TI 深信促进业界标准的重要性，并一直致力于美国 (U.S.) 及国际性自发标准的调整。作为活跃于诸多全球性的业界协会的一员，以及 TI 对环境保护负有强烈的使命感，TI 引领其无铅 (lead[Pb]-free) 计划，并逐渐成为了该方向的领导者。该计划始于上世纪 80 年代，旨在寻求产品的可替代原料，时至今日，绝大多数的 TI 产品均可提供无铅及绿色 (Green) 的封装。

如果您对“无铅”抱有任何疑问，敬请访问：

www.ti.com.cn/quality

Safe Harbor Statement:

This publication may contain forward-looking statements that involve a number of risks and uncertainties. These “forward-looking statements” are intended to qualify for the safe harbor from liability established by the Private Securities Litigation Reform Act of 1995. These forward-looking statements generally can be identified by phrases such as TI or its management “believes,” “expects,” “anticipates,” “foresees,” “forecasts,” “estimates” or other words or phrases of similar import. Similarly, such statements herein that describe the company's products, business strategy, outlook, objectives, plans, intentions or goals also are forward-looking statements. All such forward-looking statements are subject to certain risks and uncertainties that could cause actual results to differ materially from those in forward-looking statements. Please refer to TI's most recent Form 10-K for more information on the risks and uncertainties that could materially affect future results of operations. We disclaim any intention or obligation to update any forward-looking statements as a result of developments occurring after the date of this publication.

Trademarks:

The platform bar is a trademark of Texas Instruments. All other trademarks are the property of their respective owners.

Real World Signal Processing, the black/red banner, C2000, C24x, C28x, Code Composer Studio, Excalibur, Just Plug It In graphic, MicroStar BGA, MicroStar Junior, OHCI-Lynx, Power+ Logic, PowerPAD, SVIFIT, TMS320, TMS320C2000, TMS320C24x, TMS320C28x, TMS320C6000, TPS40K, XDS510 and XDS560 are trademarks of Texas Instruments. All other trademarks are the property of their respective owners.

IMPORTANT NOTICE

Texas Instruments Incorporated and its subsidiaries (TI) reserve the right to make corrections, modifications, enhancements, improvements, and other changes to its products and services at any time and to discontinue any product or service without notice. Customers should obtain the latest relevant information before placing orders and should verify that such information is current and complete. All products are sold subject to TI's terms and conditions of sale supplied at the time of order acknowledgment.

TI warrants performance of its hardware products to the specifications applicable at the time of sale in accordance with TI's standard warranty. Testing and other quality control techniques are used to the extent TI deems necessary to support this warranty. Except where mandated by government requirements, testing of all parameters of each product is not necessarily performed.

TI assumes no liability for applications assistance or customer product design. Customers are responsible for their products and applications using TI components. To minimize the risks associated with customer products and applications, customers should provide adequate design and operating safeguards.

TI does not warrant or represent that any license, either express or implied, is granted under any TI patent right, copyright, mask work right, or other TI intellectual property right relating to any combination, machine, or process in which TI products or services are used. Information published by TI regarding third-party products or services does not constitute a license from TI to use such products or services or a warranty or endorsement thereof. Use of such information may require a license from a third party under the patents or other intellectual property of the third party, or a license from TI under the patents or other intellectual property of TI.

Reproduction of TI information in TI data books or data sheets is permissible only if reproduction is without alteration and is accompanied by all associated warranties, conditions, limitations, and notices. Reproduction of this information with alteration is an unfair and deceptive business practice. TI is not responsible or liable for such altered documentation. Information of third parties may be subject to additional restrictions.

Resale of TI products or services with statements different from or beyond the parameters stated by TI for that product or service voids all express and any implied warranties for the associated TI product or service and is an unfair and deceptive business practice. TI is not responsible or liable for any such statements.

TI products are not authorized for use in safety-critical applications (such as life support) where a failure of the TI product would reasonably be expected to cause severe personal injury or death, unless officers of the parties have executed an agreement specifically governing such use. Buyers represent that they have all necessary expertise in the safety and regulatory ramifications of their applications, and acknowledge and agree that they are solely responsible for all legal, regulatory and safety-related requirements concerning their products and any use of TI products in such safety-critical applications, notwithstanding any applications-related information or support that may be provided by TI. Further, Buyers must fully indemnify TI and its representatives against any damages arising out of the use of TI products in such safety-critical applications.

TI products are neither designed nor intended for use in military/aerospace applications or environments unless the TI products are specifically designated by TI as military-grade or “enhanced plastic.” Only products designated by TI as military-grade meet military specifications. Buyers acknowledge and agree that any such use of TI products which TI has not designated as military-grade is solely at the Buyer's risk, and that they are solely responsible for compliance with all legal and regulatory requirements in connection with such use.

TI products are neither designed nor intended for use in automotive applications or environments unless the specific TI products are designated by TI as compliant with ISO/TS 16949 requirements. Buyers acknowledge and agree that, if they use any non-designated products in automotive applications, TI will not be responsible for any failure to meet such requirements.

Following are URLs where you can obtain information on other Texas Instruments products and application solutions:

相关产品链接:

- DSP - 数字信号处理器 <http://www.ti.com.cn/dsp>
- 电源管理 <http://www.ti.com.cn/power>
- 放大器和线性器件 <http://www.ti.com.cn/amplifiers>
- 接口 <http://www.ti.com.cn/interface>
- 模拟开关和多路复用器 <http://www.ti.com.cn/analogswitches>
- 逻辑 <http://www.ti.com.cn/logic>
- RF/RF 和 ZigBee® 解决方案 <http://www.ti.com.cn/radiofre>
- RFID 系统 <http://www.ti.com.cn/rfidsys>
- 数据转换器 <http://www.ti.com.cn/dataconverters>
- 时钟和计时器 <http://www.ti.com.cn/clockandtimers>
- 标准线性器件 <http://www.ti.com.cn/standardlineard>
- 温度传感器和监控器 <http://www.ti.com.cn/temperaturesensors>
- 微控制器 (MCU) <http://www.ti.com.cn/microcontrollers>

相关应用链接:

- 安防应用 <http://www.ti.com.cn/security>
- 工业应用 <http://www.ti.com.cn/industrial>
- 计算机及周边 <http://www.ti.com.cn/computer>
- 宽带网络 <http://www.ti.com.cn/broadband>
- 汽车电子 <http://www.ti.com.cn/automotive>
- 视频和影像 <http://www.ti.com.cn/video>
- 数字音频 <http://www.ti.com.cn/audio>
- 通信与电信 <http://www.ti.com.cn/telecom>
- 无线通信 <http://www.ti.com.cn/wireless>
- 消费电子 <http://www.ti.com.cn/consumer>
- 医疗电子 <http://www.ti.com.cn/medical>

重要声明

德州仪器 (TI) 及其下属子公司有权在不事先通知的情况下, 随时对所提供的产品和服务进行更正、修改、增强、改进或其它更改, 并有权随时中止提供任何产品和服务。客户在下订单前应获取最新的相关信息, 并验证这些信息是否完整且是最新的。所有产品的销售都遵循在订单确认时所提供的 TI 销售条款与条件。

TI 保证其所销售的硬件产品的性能符合 TI 标准保修的适用规范。仅在 TI 保修的范围内, 且 TI 认为有必要时才会使用测试或其它质量控制技术。除非政府做出了硬性规定, 否则没有必要对每种产品的所有参数进行测试。

TI 对应用帮助或客户产品设计不承担任何义务。客户应对其使用 TI 组件的产品和应用自行负责。为尽量减小与客户产品和应用相关的风险, 客户应提供充分的设计与操作安全措施。

TI 不对任何 TI 专利权、版权、屏蔽作品权或其它与使用了 TI 产品或服务的组合设备、机器、流程相关的 TI 知识产权中授予的直接或隐含权限作出任何保证或解释。TI 所发布的与第三方产品或服务有关的信息, 不能构成从 TI 获得使用这些产品或服务的许可、授权、或认可。使用此类信息可能需要获得第三方的专利权或其它知识产权方面的许可, 或是 TI 的专利权或其它知识产权方面的许可。

对于 TI 的数据手册或数据表, 仅在没有对内容进行任何篡改且带有相关授权、条件、限制和声明的情况下才允许进行复制。在复制信息的过程中对内容的篡改属于非法的、欺诈性商业行为。TI 对此类篡改过的文件不承担任何责任。

在转售 TI 产品或服务时, 如果存在对产品或服务参数的虚假陈述, 则会失去相关 TI 产品或服务的明示或暗示授权, 且这是非法的、欺诈性商业行为。TI 对此类虚假陈述不承担任何责任。

可访问以下 URL 地址以获取有关其它 TI 产品和应用解决方案的信息:

产品

放大器	http://www.ti.com.cn/amplifiers
数据转换器	http://www.ti.com.cn/dataconverters
DSP	http://www.ti.com.cn/dsp
接口	http://www.ti.com.cn/interface
逻辑	http://www.ti.com.cn/logic
电源管理	http://www.ti.com.cn/power
微控制器	http://www.ti.com.cn/microcontrollers

应用

音频	http://www.ti.com.cn/audio
汽车	http://www.ti.com.cn/automotive
宽带	http://www.ti.com.cn/broadband
数字控制	http://www.ti.com.cn/control
光纤网络	http://www.ti.com.cn/opticalnetwork
安全	http://www.ti.com.cn/security
电话	http://www.ti.com.cn/telecom
视频与成像	http://www.ti.com.cn/video
无线	http://www.ti.com.cn/wireless

邮寄地址: Texas Instruments, Post Office Box 655303, Dallas, Texas 75265
Copyright © 2006, Texas Instruments Incorporated