

# Improving battery safety, charging, and fuel gauging in portable media applications

By Jinrong Qian

*Battery Management Applications Manager*

## Introduction

Portable media players and smartphones have become very popular over the past five years. The portable media player is a handheld device that can record and play back audio/video from a TV, DVD player, camera, or media file downloaded from the Internet. A smartphone is a mobile phone offering advanced capabilities beyond those of a typical mobile phone, often with PC-like functionality. Most smartphones can operate as complete personal organizers that support full-featured email programs. Other features might include a miniature “qwerty” keyboard; a touch screen; a built-in camera; contact management; built-in navigation hardware and software; the ability to read business documents in a variety of formats such as Adobe® Acrobat® and Microsoft® Office files; and media software for playing music, browsing photos, and viewing video clips or Internet browsers.

The high demand of smartphones for increased power to perform these tasks reduces battery run time. A common way to extend battery run time is to design the power-conversion system to be more efficient by using high-efficiency, synchronous switching regulators instead of linear regulators. To extend the battery standby time, the DC/DC converters can be designed to optimize the light-load efficiency by operating in pulse-frequency-modulation mode, while the pulse-width-modulated controller IC operates in low-quiescent-current mode during system standby.

In addition to extending battery life, three very important parts of portable-power design are system safety, battery charging, and fuel-gauging accuracy. These are the focus of this article.

## Improving battery safety

Due to their high gravimetric and volumetric energy density, Li-Ion and Li-Polymer batteries are widely used in portable devices. One of the greatest design challenges is the safety of the battery-operated system. There have been several recalls of battery-operated portable devices such as laptop computers and cellular phones due to safety issues arising from the use of counterfeit batteries. Memory chips with a unique battery-identification number, such as the Texas Instruments (TI) bq2022A or a SHA-1-based security chip such as the TI bq26100, can verify whether a battery is from an authorized vendor and therefore safe to use.

Battery temperature is another critical parameter for battery safety. An excessive operating temperature accelerates cell degradation and causes thermal runaway and explosion in Li-Ion batteries. This is a specific concern with this type of battery because of its highly aggressive

active material. Rapid temperature increases can occur if a battery is overcharged at high current or has an internal short. During overcharging of a Li-Ion battery, active metallic lithium is deposited onto the anode. This material dramatically increases the danger of explosion that can occur when it reacts with a variety of materials, including electrolyte and cathode materials. For example, a lithium/carbon-intercalated compound reacts with water, and the released hydrogen can be ignited by the heat of the reaction. Cathode material such as  $\text{LiCoO}_2$  starts reacting with the electrolyte when the temperature exceeds its thermal-runaway threshold of  $175^\circ\text{C}$  with 4.3-V cell voltage. On the other hand, charging a battery at low temperatures also shortens battery life, since the lithium ion can be deposited onto the anode and become the metallic lithium that easily reacts with the electrolyte. The lithium ion permanently disappears and no longer participates in the energy storage.

It is very critical for a battery-charge-management circuit to monitor the battery temperature. The battery charge current and charge voltage can be adjusted to maintain battery temperature within limits specified by the manufacturer. A thermistor is usually used to monitor the Li-Ion cell temperature for cell overtemperature protection. For example, a Li-Ion battery is usually not allowed to charge when the cell temperature is below  $0^\circ\text{C}$  or above  $45^\circ\text{C}$ ; nor is it allowed to discharge when the cell temperature is above  $65^\circ\text{C}$ .

The battery is deeply discharged when its voltage is below 3.0 V. A precharge safety timer is often used to detect whether the battery has an internal short circuit. The safety timer can trigger a warning signal to be sent to the end user if the battery could not charge to 3.0 V within the specified precharge time period. The fast-charge safety timer provides another level of protection, terminating the battery charging if the timer expires due to an unexpected system failure.

Battery-charge-management ICs such as TI's bq24060 and bq24070 typically include battery-temperature monitoring and precharge and fast-charge safety timers to improve battery safety.

## Operating the system while charging a deeply discharged battery

In many portable media applications, being able to operate the system while simultaneously charging a deeply discharged battery is desirable, since the end user may make a phone call or play games regardless of the battery condition as long as the adapter is available.

Figure 1 shows a commonly used battery-charging and system-power architecture where the system is directly connected to the battery. This architecture is simple and low-cost, but connecting a system load to the battery can cause various issues.

In this configuration, the charger output current,  $I_{CHG}$ , is not dedicated to charging the battery but shared between the system and the charger. Therefore, the charger cannot directly monitor and control the battery's effective charge current.

A small precharge current is used to charge a deeply discharged battery when the cell voltage falls below 3.0 V. The system load,  $I_{SYS}$ , uses some portion of this current, making the effective charge current even smaller. This not only increases battery charging time but may also cause a false expiration of the precharge timer because the battery voltage cannot rise to 3.0 V within the precharge time period. It's even possible for the system current to be larger than the precharge current, thereby discharging the battery instead of charging it. In addition, a minimum system bus voltage of 3.0 V is usually required to operate the system in many portable applications. The system cannot operate when a deeply discharged battery voltage is used as the system bus voltage in this power architecture.

These issues are caused by the interaction between the charger and the system, which can be eliminated by powering the system and charging the battery via independent power paths. This technique is known as power-path management (PPM).

Figure 2 shows a simplified block diagram of a PPM configuration. MOSFET Q1 is used either as a switch or to preregulate the system bus voltage,  $V_{OUT}$ , at a set value such as 4.4 V (for example). Either way, a direct path from the input to the system is established for providing power to the system. MOSFET Q2 is dedicated to fully controlling the battery charging, so the system no longer interferes, and the false safety-timer expiration is completely eliminated. System operation is guaranteed and independent of the battery conditions whenever the adapter is available.

Another technique for supplying system power and charging the battery simultaneously is dynamic PPM (DPPM). DPPM monitors the system bus voltage,  $V_{OUT}$ , for drops in input power that are due to current limiting or removal of the input supply. When the current required by the system and battery charger is greater than the input current available from the AC adapter or USB, the bus

**Figure 1. Block diagram of battery-charging and system-power architecture**

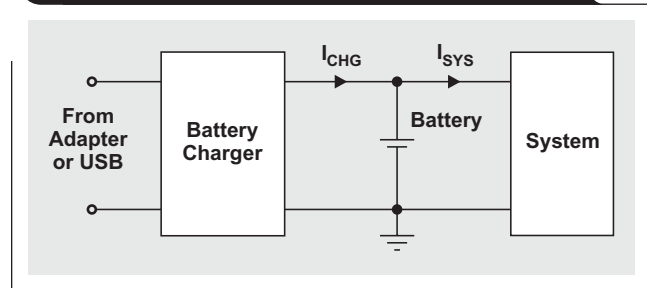

**Figure 2. Simplified block diagram of PPM battery charger**

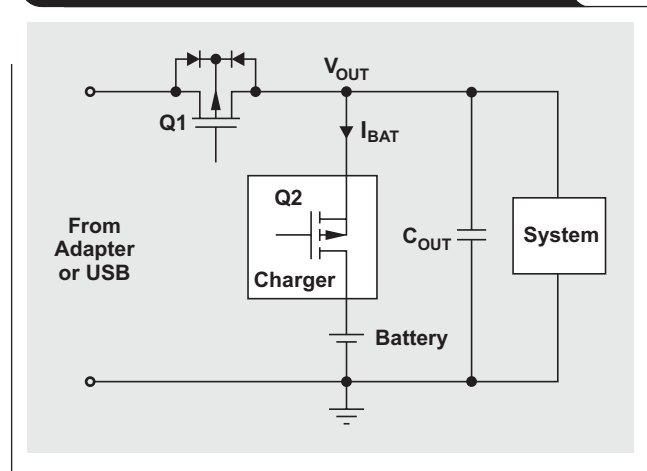

output capacitor,  $C_{OUT}$ , starts to discharge, causing the system bus voltage to drop. Once the system bus voltage falls to the preset DPPM threshold, the charge current is reduced so that the total current demand from the system and battery charger is equal to the maximum current available from the adapter. This maximizes the use of the power available from the adapter or USB. Most system loads are very dynamic, with a high peak current. Since the average power from the system is much smaller than its peak power, the adapter will be oversized if its power rating is based on the peak power from the system and battery charger. DPPM allows the designer to use a smaller power rating and a less expensive AC adapter.

**Figure 3. DPPM battery charger**

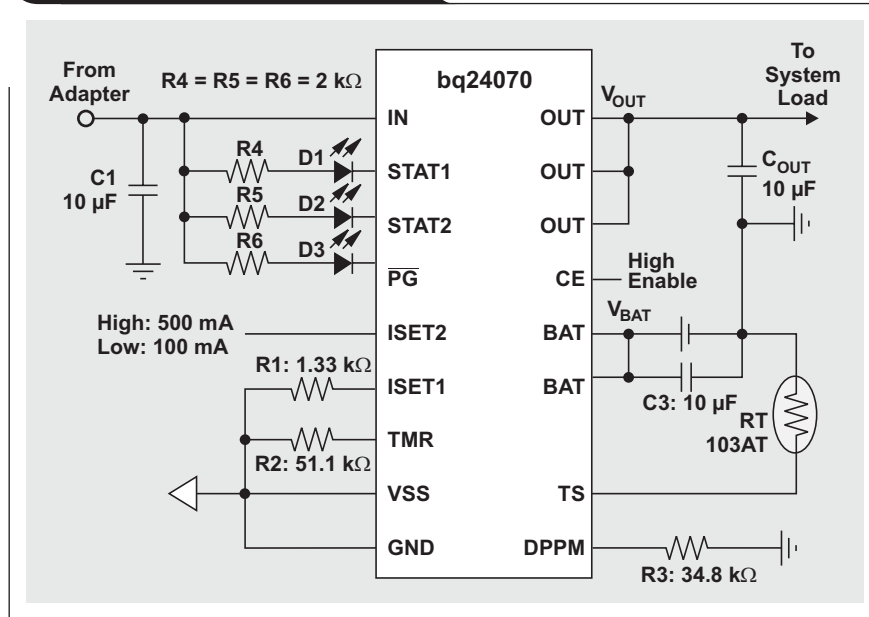

Figure 3 shows an example DPPM Li-Ion battery charger. A thermal regulation loop reduces the charge current to prevent the silicon temperature from exceeding 125°C. Whenever the charge current is reduced because of active thermal regulation or active DPPM, the safety timer's precharge time is automatically increased to eliminate a false safety-timer expiration.

**Fuel-gauging accuracy**

Some of the end user's most commonly asked questions include: "How much battery life do I have left in my portable device? How many songs or games can I play with my portable device?" A few simple bar indicators in cellular phones, for example, may not be enough to answer these questions. Battery state-of-charge (SOC) indication has evolved from a simple warning to a more complex system-level use of the information, such as soft shutdown to prevent data loss. An error in capacity estimation equivalently reduces the usable run time available to the end user. Using a capacity indicator with 10% error is the same as using a battery with 10% less capacity or a power-conversion system with 10% less efficiency.

Conventional fuel-gauging technologies, mainly the voltage-based and the coulomb-counting algorithms, have obvious performance limitations. Widely adopted in hand-held devices such as cellular phones, the voltage-based

**Figure 4. Performance of typical voltage-based fuel gauge with bar indicators**

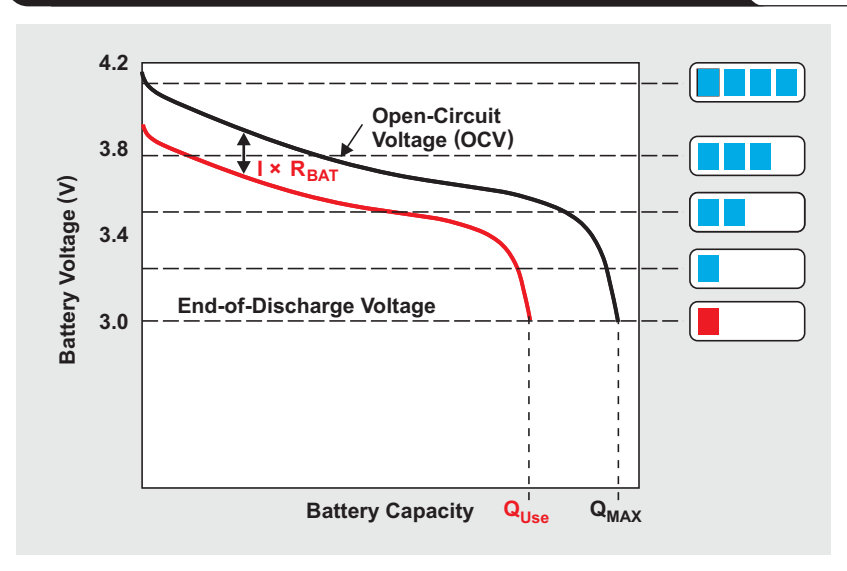

method suffers from changes in battery resistance over time. The battery voltage is given by

$$V_{BAT} = V_{OCV} - I \times R_{BAT}, \tag{1}$$

where  $V_{OCV}$  is the battery open-circuit voltage (OCV) and  $R_{BAT}$  is the battery internal DC resistance. Figure 4 shows the relationship between the battery voltage and the fuel-gauge bar indicators. Many end users have experienced fuel-gauge bar jumps and sudden system shutdown when

the usable capacity,  $Q_{Use}$ , has fallen below  $Q_{MAX}$  because of an increase in internal resistance. The coulomb-counting method takes the alternative approach by continuously integrating coulombs to compute the consumed charge and SOC. With a previously determined value for full capacity, the remaining capacity can be obtained. The drawback of this approach is that self-discharge is difficult to model since it is a function of aging and temperature. Without periodic full-cycle calibration, the gauging error accrues over time. Neither of these algorithms addresses the resistance variations of the battery. To avoid an unexpected shutdown, the designer must reserve more capacity by terminating system operation prematurely, leaving a significant amount of energy unused.

TI's patented Impedance Track™ technology is a unique and much more accurate method of determining the remaining battery capacity than either the voltage-based or the coulomb-counting algorithm alone. It actually uses both techniques to overcome the effects of aging, self-discharge and temperature variations. The Impedance Track technology implements a dynamic modeling algorithm to learn and track the battery's characteristics by first measuring and then tracking the impedance and capacity changes during actual battery use. It provides near-real-time information such as the battery's run time, maximum operating temperature, cycle count, maximum cell voltage, and maximum charging and discharging current. It is a self-learning mechanism that accounts for the no-load chemical capacity ( $Q_{MAX}$ ) and the aging effects that cause the battery's resistance to change. Compensation for load and temperature is modeled accurately with the aid of cell-impedance knowledge. With this algorithm, no periodic full-cycle capacity learning is required. System design can be relieved from conservative shutdown, allowing the battery's full capacity to be utilized. Most important, fuel-gauging accuracy can be maintained during the whole lifetime of the battery.

For Impedance Track technology to work, a database of tables must be constantly maintained to keep battery resistance ( $R_{BAT}$ ) as a function of depth of discharge (DOD) and temperature. To understand when these tables are updated or utilized, we need to know what operations occur during different states. Several current thresholds are programmed into the nonvolatile gauge memory to define a charge; a discharge; and "relaxation time," which is time that allows the battery voltage to stabilize after charging or discharging ceases.

Before a handheld device is turned on, the Impedance Track technology determines the exact SOC by measuring the battery OCV, then correlating it with the  $OCV(DOD, T)$  table stored in the IC. When the device operates in an active mode and a load is applied, current-integration-based coulomb counting begins. Integration of the passed

charge measured by the coulomb counter is used to continuously calculate the SOC.

The total battery capacity,  $Q_{MAX}$ , is generally reduced by 3 to 5% after 100 cycles. To know the real maximum capacity of the battery, we need to measure and update  $Q_{MAX}$ . The total capacity is calculated through two OCV readings taken at fully relaxed states when the variation of battery voltage is small enough before and after charge or discharge activity. As an example, before the battery is discharged, the SOC is given by

$$SOC_1 = \frac{Q_1}{Q_{MAX}}, \quad (2)$$

where  $Q_1$  is the available charge from the battery before discharge. After the battery is discharged with a passed charge of  $\Delta Q$ , the SOC is given by

$$SOC_2 = \frac{Q_2}{Q_{MAX}}, \quad (3)$$

where  $Q_2$  is the available charge from the battery after discharge. Subtracting and rearranging these two equations yields

$$Q_{MAX} = \frac{\Delta Q}{|SOC_1 - SOC_2|}, \quad (4)$$

where  $\Delta Q = Q_1 - Q_2$ . Equation 4 illustrates that it is not necessary to have a complete charge and discharge cycle to determine the total battery capacity, which means the time-consuming battery-learning cycle can be eliminated from pack manufacturing.

The battery-resistance table,  $R_{BAT}(DOD, T)$ , is updated constantly during discharge, and the resistance is calculated as

$$R_{BAT}(DOD, T) = \frac{OCV(DOD, T) - \text{Battery Voltage Under Load}}{\text{Average Load Current}}. \quad (5)$$

This enables the Impedance Track technology to compute when the termination voltage will be reached at the present load and temperature. Knowing the battery resistance, we can determine the remaining capacity (RM) using a voltage-simulation method in the firmware. Simulation starts from the present  $SOC_{Start}$ , and the future battery-voltage profile is calculated under the same load currents by decreasing SOC repeatedly in small steps. When the simulated battery voltage,  $V_{BAT}(SOC_1, T)$ , reaches the battery termination voltage, typically 3.0 V, the SOC corresponding to this voltage is captured as  $SOC_{Final}$ . RM can then be calculated as

$$RM = (SOC_{Start} - SOC_{Final}) \times Q_{MAX}. \quad (6)$$

Figure 5 shows a typical circuit that uses a system-side Impedance Track fuel gauge, the bq27500-V120, in a portable media application. To accurately compensate for the aging effect, the battery impedance is measured in real time and updated in every battery-discharge cycle. Up to 99% fuel-gauge accuracy can be achieved over the lifetime of the battery.

## Conclusion

Battery-power management plays a critical role in battery safety by preventing overcharging, overdischarging, and overtemperature conditions. The PPM battery charger can operate the system while simultaneously charging a deeply

discharged battery. PPM also eliminates charger and system interaction by providing separate power paths from the input power source to the system and the battery. The Impedance Track fuel gauge reports the remaining battery capacity with up to 99% accuracy, providing full use of all available battery energy and extending battery run time.

## Related Web sites

[power.ti.com](http://power.ti.com)

[www.ti.com/sc/device/partnumber](http://www.ti.com/sc/device/partnumber)

Replace *partnumber* with bq2022a, bq24060, bq24070, bq26100, or bq27500-V120

**Figure 5. Typical application circuit with single-cell Impedance Track fuel gauge**

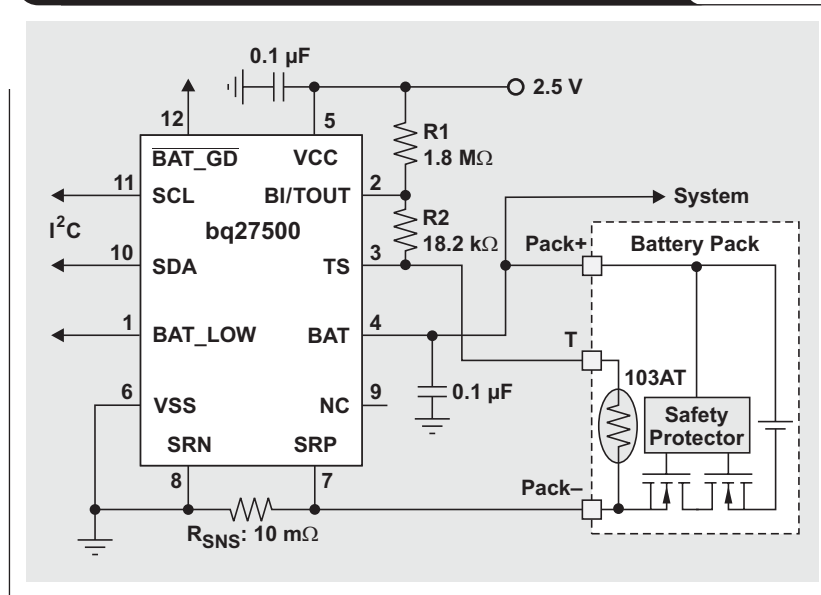

## IMPORTANT NOTICE

Texas Instruments Incorporated and its subsidiaries (TI) reserve the right to make corrections, modifications, enhancements, improvements, and other changes to its products and services at any time and to discontinue any product or service without notice. Customers should obtain the latest relevant information before placing orders and should verify that such information is current and complete. All products are sold subject to TI's terms and conditions of sale supplied at the time of order acknowledgment.

TI warrants performance of its hardware products to the specifications applicable at the time of sale in accordance with TI's standard warranty. Testing and other quality control techniques are used to the extent TI deems necessary to support this warranty. Except where mandated by government requirements, testing of all parameters of each product is not necessarily performed.

TI assumes no liability for applications assistance or customer product design. Customers are responsible for their products and applications using TI components. To minimize the risks associated with customer products and applications, customers should provide adequate design and operating safeguards.

TI does not warrant or represent that any license, either express or implied, is granted under any TI patent right, copyright, mask work right, or other TI intellectual property right relating to any combination, machine, or process in which TI products or services are used. Information published by TI regarding third-party products or services does not constitute a license from TI to use such products or services or a warranty or endorsement thereof. Use of such information may require a license from a third party under the patents or other intellectual property of the third party, or a license from TI under the patents or other intellectual property of TI.

Reproduction of information in TI data books or data sheets is permissible only if reproduction is without alteration and is accompanied by all associated warranties, conditions, limitations, and notices. Reproduction of this information with alteration is an unfair and deceptive business practice. TI is not responsible or liable for such altered documentation. Information of third parties may be subject to additional restrictions.

Resale of TI products or services with statements different from or beyond the parameters stated by TI for that product or service voids all express and any implied warranties for the associated TI product or service and is an unfair and deceptive business practice. TI is not responsible or liable for any such statements.

TI products are not authorized for use in safety-critical applications (such as life support) where a failure of the TI product would reasonably be expected to cause severe personal injury or death, unless officers of the parties have executed an agreement specifically governing such use. Buyers represent that they have all necessary expertise in the safety and regulatory ramifications of their applications, and acknowledge and agree that they are solely responsible for all legal, regulatory and safety-related requirements concerning their products and any use of TI products in such safety-critical applications, notwithstanding any applications-related information or support that may be provided by TI. Further, Buyers must fully indemnify TI and its representatives against any damages arising out of the use of TI products in such safety-critical applications.

TI products are neither designed nor intended for use in military/aerospace applications or environments unless the TI products are specifically designated by TI as military-grade or "enhanced plastic." Only products designated by TI as military-grade meet military specifications. Buyers acknowledge and agree that any such use of TI products which TI has not designated as military-grade is solely at the Buyer's risk, and that they are solely responsible for compliance with all legal and regulatory requirements in connection with such use.

TI products are neither designed nor intended for use in automotive applications or environments unless the specific TI products are designated by TI as compliant with ISO/TS 16949 requirements. Buyers acknowledge and agree that, if they use any non-designated products in automotive applications, TI will not be responsible for any failure to meet such requirements.

Following are URLs where you can obtain information on other Texas Instruments products and application solutions:

<b>Products</b>		<b>Applications</b>	
Amplifiers	<a href="http://amplifier.ti.com">amplifier.ti.com</a>	Audio	<a href="http://www.ti.com/audio">www.ti.com/audio</a>
Data Converters	<a href="http://dataconverter.ti.com">dataconverter.ti.com</a>	Automotive	<a href="http://www.ti.com/automotive">www.ti.com/automotive</a>
DLP® Products	<a href="http://www.dlp.com">www.dlp.com</a>	Broadband	<a href="http://www.ti.com/broadband">www.ti.com/broadband</a>
DSP	<a href="http://dsp.ti.com">dsp.ti.com</a>	Digital Control	<a href="http://www.ti.com/digitalcontrol">www.ti.com/digitalcontrol</a>
Clocks and Timers	<a href="http://www.ti.com/clocks">www.ti.com/clocks</a>	Medical	<a href="http://www.ti.com/medical">www.ti.com/medical</a>
Interface	<a href="http://interface.ti.com">interface.ti.com</a>	Military	<a href="http://www.ti.com/military">www.ti.com/military</a>
Logic	<a href="http://logic.ti.com">logic.ti.com</a>	Optical Networking	<a href="http://www.ti.com/opticalnetwork">www.ti.com/opticalnetwork</a>
Power Mgmt	<a href="http://power.ti.com">power.ti.com</a>	Security	<a href="http://www.ti.com/security">www.ti.com/security</a>
Microcontrollers	<a href="http://microcontroller.ti.com">microcontroller.ti.com</a>	Telephony	<a href="http://www.ti.com/telephony">www.ti.com/telephony</a>
RFID	<a href="http://www.ti-rfid.com">www.ti-rfid.com</a>	Video & Imaging	<a href="http://www.ti.com/video">www.ti.com/video</a>
RF/IF and ZigBee® Solutions	<a href="http://www.ti.com/lprf">www.ti.com/lprf</a>	Wireless	<a href="http://www.ti.com/wireless">www.ti.com/wireless</a>

Mailing Address: Texas Instruments  
Post Office Box 655303  
Dallas, Texas 75265

# TI Worldwide Technical Support

---

## Internet

### TI Semiconductor Product Information Center Home Page

[support.ti.com](http://support.ti.com)

### TI Semiconductor KnowledgeBase Home Page

[support.ti.com/sc/knowledgebase](http://support.ti.com/sc/knowledgebase)

## Product Information Centers

<b>Americas</b>	Phone	+1(972) 644-5580
<b>Brazil</b>	Phone	0800-891-2616
<b>Mexico</b>	Phone	0800-670-7544
	Fax	+1(972) 927-6377
	Internet/Email	<a href="http://support.ti.com/sc/pic/americas.htm">support.ti.com/sc/pic/americas.htm</a>

### Europe, Middle East, and Africa

Phone	
European Free Call	00800-ASK-TEXAS (00800 275 83927)
International	+49 (0) 8161 80 2121
Russian Support	+7 (4) 95 98 10 701

**Note:** The European Free Call (Toll Free) number is not active in all countries. If you have technical difficulty calling the free call number, please use the international number above.

Fax	+ (49) (0) 8161 80 2045
Internet	<a href="http://support.ti.com/sc/pic/euro.htm">support.ti.com/sc/pic/euro.htm</a>

### Japan

Fax	International	+81-3-3344-5317
	Domestic	0120-81-0036
Internet/Email	International	<a href="http://support.ti.com/sc/pic/japan.htm">support.ti.com/sc/pic/japan.htm</a>
	Domestic	<a href="http://www.tij.co.jp/pic">www.tij.co.jp/pic</a>

### Asia

Phone	
International	+91-80-41381665
Domestic	<u>Toll-Free Number</u>
Australia	1-800-999-084
China	800-820-8682
Hong Kong	800-96-5941
India	1-800-425-7888
Indonesia	001-803-8861-1006
Korea	080-551-2804
Malaysia	1-800-80-3973
New Zealand	0800-446-934
Philippines	1-800-765-7404
Singapore	800-886-1028
Taiwan	0800-006800
Thailand	001-800-886-0010
Fax	+886-2-2378-6808
Email	<a href="mailto:tiasia@ti.com">tiasia@ti.com</a> or <a href="mailto:ti-china@ti.com">ti-china@ti.com</a>
Internet	<a href="http://support.ti.com/sc/pic/asia.htm">support.ti.com/sc/pic/asia.htm</a>

**Safe Harbor Statement:** This publication may contain forward-looking statements that involve a number of risks and uncertainties. These "forward-looking statements" are intended to qualify for the safe harbor from liability established by the Private Securities Litigation Reform Act of 1995. These forward-looking statements generally can be identified by phrases such as TI or its management "believes," "expects," "anticipates," "foresees," "forecasts," "estimates" or other words or phrases of similar import. Similarly, such statements herein that describe the company's products, business strategy, outlook, objectives, plans, intentions or goals also are forward-looking statements. All such forward-looking statements are subject to certain risks and uncertainties that could cause actual results to differ materially from those in forward-looking statements. Please refer to TI's most recent Form 10-K for more information on the risks and uncertainties that could materially affect future results of operations. We disclaim any intention or obligation to update any forward-looking statements as a result of developments occurring after the date of this publication.

**E093008**

Impedance Track is a trademark of Texas Instruments. All other trademarks are the property of their respective owners.

## IMPORTANT NOTICE

Texas Instruments Incorporated and its subsidiaries (TI) reserve the right to make corrections, modifications, enhancements, improvements, and other changes to its products and services at any time and to discontinue any product or service without notice. Customers should obtain the latest relevant information before placing orders and should verify that such information is current and complete. All products are sold subject to TI's terms and conditions of sale supplied at the time of order acknowledgment.

TI warrants performance of its hardware products to the specifications applicable at the time of sale in accordance with TI's standard warranty. Testing and other quality control techniques are used to the extent TI deems necessary to support this warranty. Except where mandated by government requirements, testing of all parameters of each product is not necessarily performed.

TI assumes no liability for applications assistance or customer product design. Customers are responsible for their products and applications using TI components. To minimize the risks associated with customer products and applications, customers should provide adequate design and operating safeguards.

TI does not warrant or represent that any license, either express or implied, is granted under any TI patent right, copyright, mask work right, or other TI intellectual property right relating to any combination, machine, or process in which TI products or services are used. Information published by TI regarding third-party products or services does not constitute a license from TI to use such products or services or a warranty or endorsement thereof. Use of such information may require a license from a third party under the patents or other intellectual property of the third party, or a license from TI under the patents or other intellectual property of TI.

Reproduction of TI information in TI data books or data sheets is permissible only if reproduction is without alteration and is accompanied by all associated warranties, conditions, limitations, and notices. Reproduction of this information with alteration is an unfair and deceptive business practice. TI is not responsible or liable for such altered documentation. Information of third parties may be subject to additional restrictions.

Resale of TI products or services with statements different from or beyond the parameters stated by TI for that product or service voids all express and any implied warranties for the associated TI product or service and is an unfair and deceptive business practice. TI is not responsible or liable for any such statements.

TI products are not authorized for use in safety-critical applications (such as life support) where a failure of the TI product would reasonably be expected to cause severe personal injury or death, unless officers of the parties have executed an agreement specifically governing such use. Buyers represent that they have all necessary expertise in the safety and regulatory ramifications of their applications, and acknowledge and agree that they are solely responsible for all legal, regulatory and safety-related requirements concerning their products and any use of TI products in such safety-critical applications, notwithstanding any applications-related information or support that may be provided by TI. Further, Buyers must fully indemnify TI and its representatives against any damages arising out of the use of TI products in such safety-critical applications.

TI products are neither designed nor intended for use in military/aerospace applications or environments unless the TI products are specifically designated by TI as military-grade or "enhanced plastic." Only products designated by TI as military-grade meet military specifications. Buyers acknowledge and agree that any such use of TI products which TI has not designated as military-grade is solely at the Buyer's risk, and that they are solely responsible for compliance with all legal and regulatory requirements in connection with such use.

TI products are neither designed nor intended for use in automotive applications or environments unless the specific TI products are designated by TI as compliant with ISO/TS 16949 requirements. Buyers acknowledge and agree that, if they use any non-designated products in automotive applications, TI will not be responsible for any failure to meet such requirements.

Following are URLs where you can obtain information on other Texas Instruments products and application solutions:

### Products

Amplifiers	<a href="http://amplifier.ti.com">amplifier.ti.com</a>
Data Converters	<a href="http://dataconverter.ti.com">dataconverter.ti.com</a>
DLP® Products	<a href="http://www.dlp.com">www.dlp.com</a>
DSP	<a href="http://dsp.ti.com">dsp.ti.com</a>
Clocks and Timers	<a href="http://www.ti.com/clocks">www.ti.com/clocks</a>
Interface	<a href="http://interface.ti.com">interface.ti.com</a>
Logic	<a href="http://logic.ti.com">logic.ti.com</a>
Power Mgmt	<a href="http://power.ti.com">power.ti.com</a>
Microcontrollers	<a href="http://microcontroller.ti.com">microcontroller.ti.com</a>
RFID	<a href="http://www.ti-rfid.com">www.ti-rfid.com</a>
RF/IF and ZigBee® Solutions	<a href="http://www.ti.com/lprf">www.ti.com/lprf</a>

### Applications

Audio	<a href="http://www.ti.com/audio">www.ti.com/audio</a>
Automotive	<a href="http://www.ti.com/automotive">www.ti.com/automotive</a>
Broadband	<a href="http://www.ti.com/broadband">www.ti.com/broadband</a>
Digital Control	<a href="http://www.ti.com/digitalcontrol">www.ti.com/digitalcontrol</a>
Medical	<a href="http://www.ti.com/medical">www.ti.com/medical</a>
Military	<a href="http://www.ti.com/military">www.ti.com/military</a>
Optical Networking	<a href="http://www.ti.com/opticalnetwork">www.ti.com/opticalnetwork</a>
Security	<a href="http://www.ti.com/security">www.ti.com/security</a>
Telephony	<a href="http://www.ti.com/telephony">www.ti.com/telephony</a>
Video & Imaging	<a href="http://www.ti.com/video">www.ti.com/video</a>
Wireless	<a href="http://www.ti.com/wireless">www.ti.com/wireless</a>

Mailing Address: Texas Instruments, Post Office Box 655303, Dallas, Texas 75265  
Copyright © 2009, Texas Instruments Incorporated