

TMUX6104 36V、低电容、低泄漏电流、 精密 4:1 模拟多路复用器

1 特性

- 低导通电容: 5pF
- 低输入泄漏: 5pA
- 低电荷注入: 0.35pC
- 轨至轨运行
- 宽电压范围: $\pm 5V$ 至 $\pm 16.5V$ (双电源) 或 10V 至 16.5V (单电源)
- 低导通电阻: 125 Ω
- 转换时间: 88ns
- 先断后合开关操作
- EN 引脚与 V_{DD} 相连 (集成下拉电阻器)
- 逻辑电平: 2V 至 V_{DD}
- 低电源电流: 17 μA
- ESD 保护 HBM: 2000V
- 符合行业标准的薄型小外形尺寸 (TSSOP) 封装:

2 应用

- 工厂自动化和工业过程控制
- 可编程逻辑控制器 (PLC)
- 模拟输入模块
- 自动测试设备 (ATE)
- 数字万用表
- 电池监控系统

3 说明

TMUX6104 是一款现代互补金属氧化物半导体 (CMOS) 模拟多路复用器, 可提供 4:1 单端多路复用。这些器件在双电源 ($\pm 5V$ 至 $\pm 16.5V$)、单电源 (10V 至 16.5V) 或不对称电源 (例如 $V_{DD} = 12V$, $V_{SS} = -5V$) 供电情况下运行良好。所有数字输入均具有兼容晶体管到晶体管逻辑 (TTL) 的阈值, 这些阈值可确保 TTL 和 CMOS 逻辑兼容性。

TMUX6104 会根据地址引脚 (A0/A1) 和使能引脚 (EN) 的状态将四个输入中的一个 (S_x) 多路复用为共模输出 (D)。每个开关在“ON”位置时在两个方向上表现得都很好, 而且支持最高到电源的输入信号范围。在 OFF 状态下, 则会阻止最高到电源的信号电平。所有开关都具有先断后合 (BBM) 开关操作。

TMUX6104 器件是德州仪器 (TI) 精密开关和多路复用器系列的一部分。该系列器件具有非常低的泄漏电流和电荷注入, 因此可用于高精度测量应用中。这些器件的电源电流低至 17 μA , 因此可用于便携式应用。

器件信息⁽¹⁾

器件型号	封装	封装尺寸 (标称值)
TMUX6104	TSSOP (14)	5.00mm x 4.40mm

(1) 如需了解所有可用封装, 请参阅数据表末尾的封装选项附录。

简化原理图

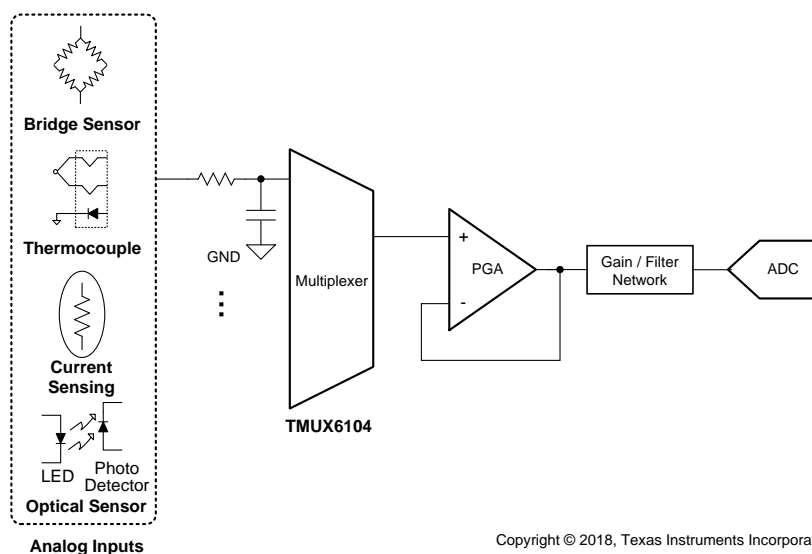

目录

1	特性	1	8.2	Functional Block Diagram	18
2	应用	1	8.3	Feature Description	18
3	说明	1	8.4	Device Functional Modes	20
4	修订历史记录	2	9	Application and Implementation	21
5	Pin Configuration and Functions	3	9.1	Application Information	21
6	Specifications	4	9.2	Typical Application	21
6.1	Absolute Maximum Ratings	4	10	Power Supply Recommendations	23
6.2	ESD Ratings	4	11	Layout	24
6.3	Thermal Information	4	11.1	Layout Guidelines	24
6.4	Recommended Operating Conditions	4	11.2	Layout Example	24
6.5	Electrical Characteristics (Dual Supplies: ± 15 V)	5	12	器件和文档支持	25
6.6	Switching Characteristics (Dual Supplies: ± 15 V)	6	12.1	文档支持	25
6.7	Electrical Characteristics (Single Supply: 12 V)	6	12.2	接收文档更新通知	25
6.8	Switching Characteristics (Single Supply: 12 V)	7	12.3	社区资源	25
6.9	Typical Characteristics	9	12.4	商标	25
7	Parameter Measurement Information	11	12.5	静电放电警告	25
7.1	Truth Table	11	12.6	术语表	25
8	Detailed Description	12	13	机械、封装和可订购信息	25
8.1	Overview	12			

4 修订历史记录

注：之前版本的页码可能与当前版本有所不同。

Changes from Original (February 2018) to Revision A

Page

•	将器件状态从预告信息 更改为生产数据	1
---	--------------------------	----------

5 Pin Configuration and Functions

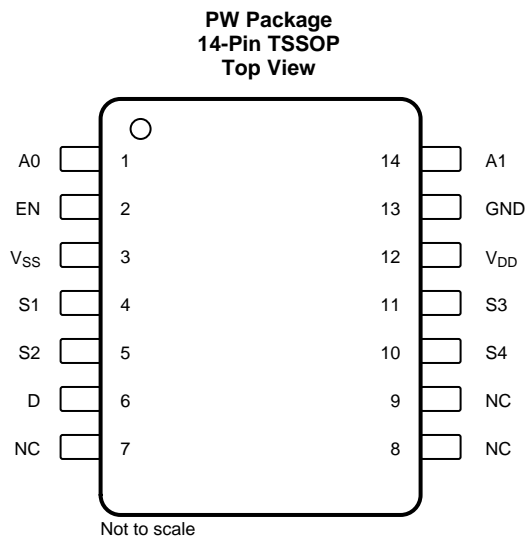

Pin Functions

PIN		TYPE	DESCRIPTION
NAME	NO.		
A0	1	I	Address line 0
A1	14	I	Address line 1
D	6	I/O	Drain pin. Can be an input or output.
EN	2	I	Active high digital input. When this pin is low, all switches are turned off. When this pin is high, the A0 and A1 logic inputs determine which switch is turned on.
GND	13	P	Ground (0 V) reference
NC	7, 8, 9	No Connect	No internal connection
S1	4	I/O	Source pin 1. Can be an input or output.
S2	5	I/O	Source pin 2. Can be an input or output.
S3	11	I/O	Source pin 3. Can be an input or output.
S4	10	I/O	Source pin 4. Can be an input or output.
V _{DD}	12	P	Positive power supply. This pin is the most positive power-supply potential. For reliable operation, connect a decoupling capacitor ranging from 0.1 μ F to 10 μ F between V _{DD} and GND.
V _{SS}	3	P	Negative power supply. This pin is the most negative power-supply potential. In single-supply applications, this pin can be connected to ground. For reliable operation, connect a decoupling capacitor ranging from 0.1 μ F to 10 μ F between V _{SS} and GND.

6 Specifications

6.1 Absolute Maximum Ratings

 over operating free-air temperature range (unless otherwise noted)⁽¹⁾

		MIN	MAX	UNIT
V _{DD} to V _{SS}	Supply voltage		36	V
V _{DD} to GND		-0.3	18	V
V _{SS} to GND		-18	0.3	V
V _{DIG}	Digital input pin (EN, A0, A1) voltage	GND -0.3	V _{DD} +0.3	V
I _{DIG}	Digital input pin (EN, A0, A1) current	-30	30	mA
V _{ANA_IN}	Analog input pin (Sx) voltage	V _{SS} -0.3	V _{DD} +0.3	V
I _{ANA_IN}	Analog input pin (Sx) current	-30	30	mA
V _{ANA_OUT}	Analog output pin (D) voltage	V _{SS} -0.3	V _{DD} +0.3	V
I _{ANA_OUT}	Analog output pin (D) current	-30	30	mA
T _A	Ambient temperature	-55	125	°C
T _J	Junction temperature		150	°C
T _{stg}	Storage temperature	-65	150	°C

(1) Stresses beyond those listed under *Absolute Maximum Rating* may cause permanent damage to the device. These are stress ratings only, which do not imply functional operation of the device at these or any other conditions beyond those indicated under *Recommended Operating Condition*. Exposure to absolute-maximum-rated conditions for extended periods may affect device reliability.

6.2 ESD Ratings

			VALUE	UNIT
V _(ESD)	Electrostatic discharge	Human body model (HBM), per ANSI/ESDA/JEDEC JS-001, all pins ⁽¹⁾	±2000	V
		Charged device model (CDM), per JEDEC specification JESD22-C101, all pins ⁽²⁾	±500	

(1) JEDEC document JEP155 states that 500-V HBM allows safe manufacturing with a standard ESD control process.

(2) JEDEC document JEP157 states that 250-V CDM allows safe manufacturing with a standard ESD control process.

6.3 Thermal Information

THERMAL METRIC ⁽¹⁾		TMUX6104	UNIT
		PW (TSSOP)	
		14 PINS	
R _{θJA}	Junction-to-ambient thermal resistance	122.4	°C/W
R _{θJC(top)}	Junction-to-case (top) thermal resistance	52.0	°C/W
R _{θJB}	Junction-to-board thermal resistance	65.4	°C/W
Ψ _{JT}	Junction-to-top characterization parameter	8.1	°C/W
Ψ _{JB}	Junction-to-board characterization parameter	64.8	°C/W
R _{θJC(bot)}	Junction-to-case (bottom) thermal resistance	N/A	°C/W

(1) For more information about traditional and new thermal metrics, see the [Semiconductor and IC Package Thermal Metrics](#) application report.

6.4 Recommended Operating Conditions

over operating free-air temperature range (unless otherwise noted)

		MIN	NOM	MAX	UNIT
V _{DD} to V _{SS} ⁽¹⁾	Power supply voltage differential	10		33	V
V _{DD} to GND	Positive power supply voltage (single supply, V _{SS} = 0 V)	10		16.5	V
V _{DD} to GND	Positive power supply voltage (dual supply)	5		16.5	V
V _{SS} to GND	Negative power supply voltage (dual supply)	-5		-16.5	V

(1) V_{DD} and V_{SS} can be any value as long as 10 V ≤ (V_{DD} - V_{SS}) ≤ 33 V.

Recommended Operating Conditions (continued)

over operating free-air temperature range (unless otherwise noted)

		MIN	NOM	MAX	UNIT
$V_S^{(2)}$	Source pins voltage	V_{SS}		V_{DD}	V
V_D	Drain pin voltage	V_{SS}		V_{DD}	V
V_{DIG}	Digital input pin (EN, A0, A1) voltage	0		V_{DD}	V
I_{CH}	Channel current ($T_A = 25^\circ\text{C}$)	-25		25	mA
T_A	Ambient temperature	-40		125	$^\circ\text{C}$

(2) V_S is the voltage on all the S pins.

6.5 Electrical Characteristics (Dual Supplies: $\pm 15\text{ V}$)

at $T_A = 25^\circ\text{C}$, $V_{DD} = 15\text{ V}$, and $V_{SS} = -15\text{ V}$ (unless otherwise noted)

PARAMETER		TEST CONDITIONS		MIN	TYP	MAX	UNIT	
ANALOG SWITCH								
V_A	Analog signal range		$T_A = -40^\circ\text{C}$ to $+125^\circ\text{C}$	V_{SS}		V_{DD}	V	
R_{ON}	On-resistance	$V_S = 0\text{ V}$, $I_S = 1\text{ mA}$			125	170	Ω	
					145	200	Ω	
		$V_S = \pm 10\text{ V}$, $I_S = 1\text{ mA}$	$T_A = -40^\circ\text{C}$ to $+85^\circ\text{C}$		230	Ω		
			$T_A = -40^\circ\text{C}$ to $+125^\circ\text{C}$		250	Ω		
ΔR_{ON}	On-resistance mismatch between channels	$V_S = \pm 10\text{ V}$, $I_S = 1\text{ mA}$	$T_A = -40^\circ\text{C}$ to $+85^\circ\text{C}$		1.5	6	Ω	
			$T_A = -40^\circ\text{C}$ to $+125^\circ\text{C}$			9	Ω	
R_{ON_FLAT}	On-resistance flatness	$V_S = -10\text{ V}$, 0 V , $+10\text{ V}$, $I_S = 1\text{ mA}$	$T_A = -40^\circ\text{C}$ to $+85^\circ\text{C}$		26	45	Ω	
			$T_A = -40^\circ\text{C}$ to $+125^\circ\text{C}$			53	Ω	
R_{ON_DRIFT}	On-resistance drift	$V_S = 0\text{ V}$			0.5		$\Omega/^\circ\text{C}$	
$I_{S(OFF)}$	Source off leakage current ⁽¹⁾	Switch state is off, $V_S = +10\text{ V}/-10\text{ V}$, $V_D = -10\text{ V}/+10\text{ V}$	$T_A = -40^\circ\text{C}$ to $+85^\circ\text{C}$	-0.02	0.005	0.02	nA	
			$T_A = -40^\circ\text{C}$ to $+125^\circ\text{C}$		-0.13		0.05	nA
$I_{D(OFF)}$	Drain off leakage current ⁽¹⁾	Switch state is off, $V_S = +10\text{ V}/-10\text{ V}$, $V_D = -10\text{ V}/+10\text{ V}$	$T_A = -40^\circ\text{C}$ to $+85^\circ\text{C}$		-0.05	0.01	0.05	nA
			$T_A = -40^\circ\text{C}$ to $+125^\circ\text{C}$		-0.14		0.1	nA
$I_{D(ON)}$	Drain on leakage current	Switch state is on, $V_S = +10\text{ V}/-10\text{ V}$, $V_D = -10\text{ V}/+10\text{ V}$	$T_A = -40^\circ\text{C}$ to $+85^\circ\text{C}$		-0.07	0.01	0.07	nA
			$T_A = -40^\circ\text{C}$ to $+125^\circ\text{C}$		-0.27		0.15	nA
			$T_A = -40^\circ\text{C}$ to $+125^\circ\text{C}$		-2	1	nA	
DIGITAL INPUT (EN, Ax pins)								
V_{IH}	Logic voltage high		$T_A = -40^\circ\text{C}$ to $+125^\circ\text{C}$	2			V	
V_{IL}	Logic voltage low		$T_A = -40^\circ\text{C}$ to $+125^\circ\text{C}$			0.8	V	
$R_{PD(EN)}$	Pull-down resistance on EN pin				6		M Ω	
POWER SUPPLY								
I_{DD}	V_{DD} supply current	$V_A = 0\text{ V}$ or 3.3 V , $V_S = 0\text{ V}$, $V_{EN} = 3.3\text{ V}$	$T_A = -40^\circ\text{C}$ to $+85^\circ\text{C}$		17	24	μA	
			$T_A = -40^\circ\text{C}$ to $+125^\circ\text{C}$			25	μA	
			$T_A = -40^\circ\text{C}$ to $+125^\circ\text{C}$			27	μA	
I_{SS}	V_{SS} supply current	$V_A = 0\text{ V}$ or 3.3 V , $V_S = 0\text{ V}$, $V_{EN} = 3.3\text{ V}$	$T_A = -40^\circ\text{C}$ to $+85^\circ\text{C}$		7	12	μA	
			$T_A = -40^\circ\text{C}$ to $+125^\circ\text{C}$			13	μA	
			$T_A = -40^\circ\text{C}$ to $+125^\circ\text{C}$			15	μA	

(1) When V_S is positive, V_D is negative, and vice versa.

6.6 Switching Characteristics (Dual Supplies: ±15 V)

 at $T_A = 25^\circ\text{C}$, $V_{DD} = 15\text{ V}$, and $V_{SS} = -15\text{ V}$ (unless otherwise noted)

PARAMETER		TEST CONDITIONS	MIN	TYP	MAX	UNIT
t_{ON}	Enable turn-on time	$V_S = \pm 10\text{ V}$, $R_L = 300\ \Omega$, $C_L = 35\text{ pF}$		85	120	ns
		$V_S = \pm 10\text{ V}$, $R_L = 300\ \Omega$, $C_L = 35\text{ pF}$, $T_A = -40^\circ\text{C}$ to $+85^\circ\text{C}$			130	ns
		$V_S = \pm 10\text{ V}$, $R_L = 300\ \Omega$, $C_L = 35\text{ pF}$, $T_A = -40^\circ\text{C}$ to $+125^\circ\text{C}$			140	ns
t_{OFF}	Enable turn-off time	$V_S = \pm 10\text{ V}$, $R_L = 300\ \Omega$, $C_L = 35\text{ pF}$		53	65	ns
		$V_S = \pm 10\text{ V}$, $R_L = 300\ \Omega$, $C_L = 35\text{ pF}$, $T_A = -40^\circ\text{C}$ to $+85^\circ\text{C}$			70	ns
		$V_S = \pm 10\text{ V}$, $R_L = 300\ \Omega$, $C_L = 35\text{ pF}$, $T_A = -40^\circ\text{C}$ to $+125^\circ\text{C}$			75	ns
t_{TRAN}	Transition time	$V_S = 10\text{ V}$, $R_L = 300\ \Omega$, $C_L = 35\text{ pF}$		88	125	ns
		$V_S = 10\text{ V}$, $R_L = 300\ \Omega$, $C_L = 35\text{ pF}$, $T_A = -40^\circ\text{C}$ to $+85^\circ\text{C}$			135	ns
		$V_S = 10\text{ V}$, $R_L = 300\ \Omega$, $C_L = 35\text{ pF}$, $T_A = -40^\circ\text{C}$ to $+125^\circ\text{C}$			145	ns
t_{BBM}	Break-before-make time delay	$V_S = 10\text{ V}$, $R_L = 300\ \Omega$, $C_L = 35\text{ pF}$, $T_A = -40^\circ\text{C}$ to $+125^\circ\text{C}$	30	50		ns
Q_J	Charge injection	$V_S = 0\text{ V}$, $R_S = 0\ \Omega$, $C_L = 1\text{ nF}$		-0.35		pC
		$V_S = -15\text{ V}$ to 15 V , $R_S = 0\ \Omega$, $C_L = 1\text{ nF}$		-0.41		pC
O_{ISO}	Off-isolation	$R_L = 50\ \Omega$, $C_L = 5\text{ pF}$, $f = 1\text{ MHz}$		-86		dB
X_{TALK}	Channel-to-channel crosstalk	$R_L = 50\ \Omega$, $C_L = 5\text{ pF}$, $f = 1\text{ MHz}$, non-adjacent channels		-105		dB
		$R_L = 50\ \Omega$, $C_L = 5\text{ pF}$, $f = 1\text{ MHz}$, adjacent channels		-87		dB
I_L	Insertion loss	$R_L = 50\ \Omega$, $C_L = 5\text{ pF}$, $f = 1\text{ MHz}$		-7		dB
ACPSRR	AC Power Supply Rejection Ratio	$R_L = 10\text{ k}\Omega$, $C_L = 5\text{ pF}$, $V_{PP} = 0.62\text{ V}$ on V_{DD} , $f = 1\text{ MHz}$		-52		dB
		$R_L = 10\text{ k}\Omega$, $C_L = 5\text{ pF}$, $V_{PP} = 0.62\text{ V}$ on V_{SS} , $f = 1\text{ MHz}$		-49		dB
BW	-3dB Bandwidth	$R_L = 50\ \Omega$, $C_L = 5\text{ pF}$		500		MHz
THD + N	Total harmonic distortion + noise	$R_L = 10\text{ k}\Omega$, $C_L = 5\text{ pF}$, $f = 20\text{ Hz}$ to 20 kHz		0.08		%
C_{IN}	Digital input capacitance	$V_{IN} = 0\text{ V}$ or V_{DD}		1.2		pF
$C_{S(OFF)}$	Source off-capacitance	$V_S = 0\text{ V}$, $f = 1\text{ MHz}$		1.6	2.3	pF
$C_{D(OFF)}$	Drain off-capacitance	$V_S = 0\text{ V}$, $f = 1\text{ MHz}$		3.8	4.2	pF
$C_{S(ON)}$, $C_{D(ON)}$	Source and drain on-capacitance	$V_S = 0\text{ V}$, $f = 1\text{ MHz}$		5.0	6.5	pF

6.7 Electrical Characteristics (Single Supply: 12 V)

 at $T_A = 25^\circ\text{C}$, $V_{DD} = 12\text{ V}$, and $V_{SS} = 0\text{ V}$ (unless otherwise noted)

PARAMETER		TEST CONDITIONS		MIN	TYP	MAX	UNIT
ANALOG SWITCH							
V_A	Analog signal range	$T_A = -40^\circ\text{C}$ to $+125^\circ\text{C}$	$T_A = -40^\circ\text{C}$ to $+125^\circ\text{C}$	V_{SS}		V_{DD}	V
R_{ON}	On-resistance	$V_S = 10\text{ V}$, $I_S = 1\text{ mA}$			235	345	Ω
			$T_A = -40^\circ\text{C}$ to $+85^\circ\text{C}$			400	Ω
			$T_A = -40^\circ\text{C}$ to $+125^\circ\text{C}$			440	Ω
ΔR_{ON}	On-resistance mismatch between channels	$V_S = 10\text{ V}$, $I_S = 1\text{ mA}$			2.4	12	Ω
			$T_A = -40^\circ\text{C}$ to $+85^\circ\text{C}$			19	Ω
			$T_A = -40^\circ\text{C}$ to $+125^\circ\text{C}$			23	Ω
R_{ON_DRIFT}	On-resistance drift	$V_S = 0\text{ V}$			0.47		%/ $^\circ\text{C}$

Electrical Characteristics (Single Supply: 12 V) (continued)

at $T_A = 25^\circ\text{C}$, $V_{DD} = 12\text{ V}$, and $V_{SS} = 0\text{ V}$ (unless otherwise noted)

PARAMETER		TEST CONDITIONS		MIN	TYP	MAX	UNIT
$I_{S(OFF)}$	Source off leakage current ⁽¹⁾	Switch state is off, $V_S = 10\text{ V}/1\text{ V}$, $V_D = 1\text{ V}/10\text{ V}$		-0.02	0.005	0.02	nA
			$T_A = -40^\circ\text{C}$ to $+85^\circ\text{C}$	-0.1		0.05	nA
			$T_A = -40^\circ\text{C}$ to $+125^\circ\text{C}$	-0.8		0.4	nA
$I_{D(OFF)}$	Drain off leakage current ⁽¹⁾	Switch state is off, $V_S = 10\text{ V}/1\text{ V}$, $V_D = 1\text{ V}/10\text{ V}$		-0.03	0.01	0.03	nA
			$T_A = -40^\circ\text{C}$ to $+85^\circ\text{C}$	-0.1		0.08	nA
			$T_A = -40^\circ\text{C}$ to $+125^\circ\text{C}$	-0.8		0.4	nA
$I_{D(ON)}$	Drain on leakage current	Switch state is on, $V_S =$ floating, $V_D = 1\text{ V}/10\text{ V}$		-0.05	0.01	0.05	nA
			$T_A = -40^\circ\text{C}$ to $+85^\circ\text{C}$	-0.2		0.15	nA
			$T_A = -40^\circ\text{C}$ to $+125^\circ\text{C}$	-1.6		0.8	nA
DIGITAL INPUT (EN, Ax pins)							
V_{IH}	Logic voltage high		$T_A = -40^\circ\text{C}$ to $+125^\circ\text{C}$	2			V
V_{IL}	Logic voltage low		$T_A = -40^\circ\text{C}$ to $+125^\circ\text{C}$			0.8	V
$R_{PD(EN)}$	Pull-down resistance on EN pin				6		M Ω
POWER SUPPLY							
I_{DD}	V_{DD} supply current	$V_A = 0\text{ V}$ or 3.3 V , $V_S = 0\text{ V}$, $V_{EN} = 3.3\text{ V}$			12	18	μA
			$T_A = -40^\circ\text{C}$ to $+85^\circ\text{C}$			19	μA
			$T_A = -40^\circ\text{C}$ to $+125^\circ\text{C}$			21	μA

(1) When V_S is positive, V_D is negative, and vice versa.

6.8 Switching Characteristics (Single Supply: 12 V)

at $T_A = 25^\circ\text{C}$, $V_{DD} = 12\text{ V}$, and $V_{SS} = 0\text{ V}$ (unless otherwise noted)

PARAMETER		TEST CONDITIONS		MIN	TYP	MAX	UNIT
t_{ON}	Enable turn-on time	$V_S = 8\text{ V}$, $R_L = 300\ \Omega$, $C_L = 35\text{ pF}$			91	125	ns
		$V_S = 8\text{ V}$, $R_L = 300\ \Omega$, $C_L = 35\text{ pF}$, $T_A = -40^\circ\text{C}$ to $+85^\circ\text{C}$				135	ns
		$V_S = 8\text{ V}$, $R_L = 300\ \Omega$, $C_L = 35\text{ pF}$, $T_A = -40^\circ\text{C}$ to $+125^\circ\text{C}$				145	ns
t_{OFF}	Enable turn-off time	$V_S = 8\text{ V}$, $R_L = 300\ \Omega$, $C_L = 35\text{ pF}$			52	60	ns
		$V_S = 8\text{ V}$, $R_L = 300\ \Omega$, $C_L = 35\text{ pF}$, $T_A = -40^\circ\text{C}$ to $+85^\circ\text{C}$				70	ns
		$V_S = 8\text{ V}$, $R_L = 300\ \Omega$, $C_L = 35\text{ pF}$, $T_A = -40^\circ\text{C}$ to $+125^\circ\text{C}$				77	ns
t_{TRAN}	Transition time	$V_S = 8\text{ V}$, $R_L = 300\ \Omega$, $C_L = 35\text{ pF}$			94	127	ns
		$V_S = 8\text{ V}$, $R_L = 300\ \Omega$, $C_L = 35\text{ pF}$, $T_A = -40^\circ\text{C}$ to $+85^\circ\text{C}$				140	ns
		$V_S = 8\text{ V}$, $R_L = 300\ \Omega$, $C_L = 35\text{ pF}$, $T_A = -40^\circ\text{C}$ to $+125^\circ\text{C}$				150	ns
t_{BBM}	Break-before-make time delay	$V_S = 8\text{ V}$, $R_L = 300\ \Omega$, $C_L = 35\text{ pF}$, $T_A = -40^\circ\text{C}$ to $+125^\circ\text{C}$		30	55		ns
Q_J	Charge injection	$V_S = 6\text{ V}$, $R_S = 0\ \Omega$, $C_L = 1\text{ nF}$			-0.2		pC
		$V_S = 0\text{ V}$ to 12 V , $R_S = 0\ \Omega$, $C_L = 1\text{ nF}$			-0.2		pC
O_{ISO}	Off-isolation	$R_L = 50\ \Omega$, $C_L = 5\text{ pF}$, $f = 1\text{ MHz}$			-86		dB
X_{TALK}	Channel-to-channel crosstalk	$R_L = 50\ \Omega$, $C_L = 5\text{ pF}$, $f = 1\text{ MHz}$, non-adjacent channels			-107		dB
		$R_L = 50\ \Omega$, $C_L = 5\text{ pF}$, $f = 1\text{ MHz}$, adjacent channels			-87		dB
I_L	Insertion loss	$R_L = 50\ \Omega$, $C_L = 5\text{ pF}$, $f = 1\text{ MHz}$			-14		dB
ACPSRR	AC Power Supply Rejection Ratio	$R_L = 10\text{ k}\Omega$, $C_L = 5\text{ pF}$, $V_{PP} = 0.62\text{ V}$, $f = 1\text{ MHz}$			-51		dB
BW	-3dB Bandwidth	$R_L = 50\ \Omega$, $C_L = 5\text{ pF}$			400		MHz

TMUX6104

ZHCSHO7A – FEBRUARY 2018 – REVISED SEPTEMBER 2018

www.ti.com.cn
Switching Characteristics (Single Supply: 12 V) (continued)

 at $T_A = 25^\circ\text{C}$, $V_{DD} = 12\text{ V}$, and $V_{SS} = 0\text{ V}$ (unless otherwise noted)

PARAMETER		TEST CONDITIONS	MIN	TYP	MAX	UNIT
C_{IN}	Digital input capacitance	$V_{IN} = 0\text{ V}$ or V_{DD}		1.2		pF
$C_{S(OFF)}$	Source off-capacitance	$V_S = 6\text{ V}$, $f = 1\text{ MHz}$		1.9	2.3	pF
$C_{D(OFF)}$	Drain off-capacitance	$V_S = 6\text{ V}$, $f = 1\text{ MHz}$		4.6	5.3	pF
$C_{S(ON)}$, $C_{D(ON)}$	Source and drain on-capacitance	$V_S = 6\text{ V}$, $f = 1\text{ MHz}$		6.3	7.5	pF

6.9 Typical Characteristics

at $T_A = 25^\circ\text{C}$, $V_{DD} = 15\text{ V}$, and $V_{SS} = -15\text{ V}$ (unless otherwise noted)



图 1. On-Resistance vs Source or Drain Voltage



图 2. On-Resistance vs Source or Drain Voltage

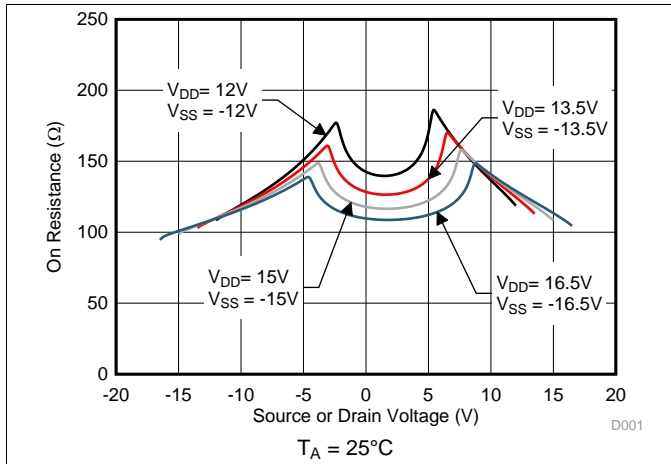

图 3. On-Resistance vs Source or Drain Voltage

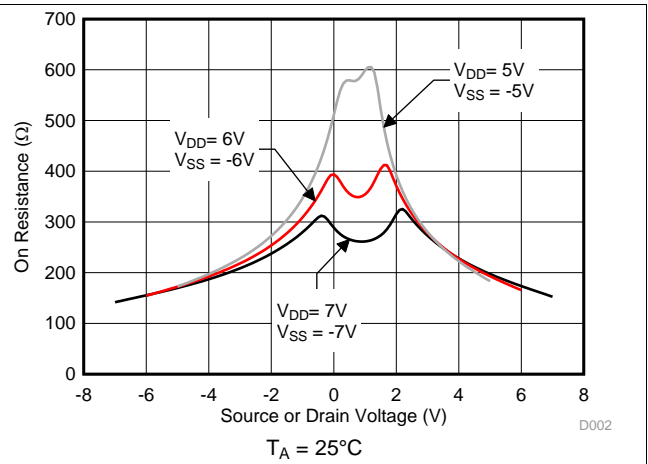

图 4. On-Resistance vs Source or Drain Voltage

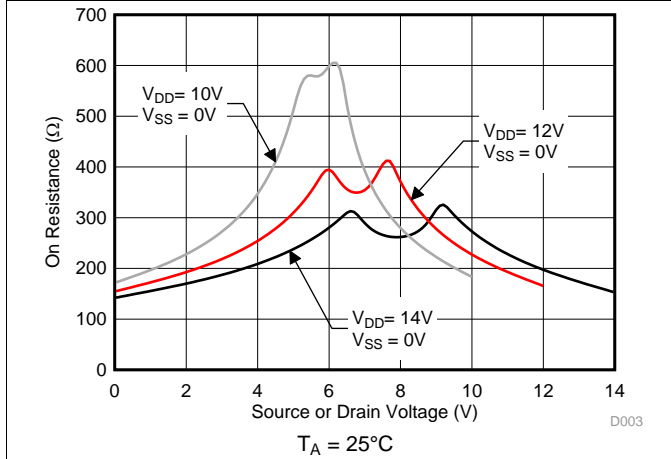

图 5. On-Resistance vs Source or Drain Voltage

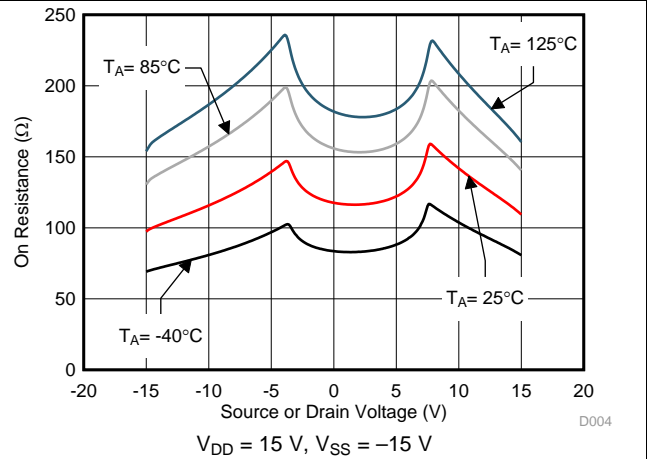

图 6. Leakage Current vs Temperature

Typical Characteristics (接下页)

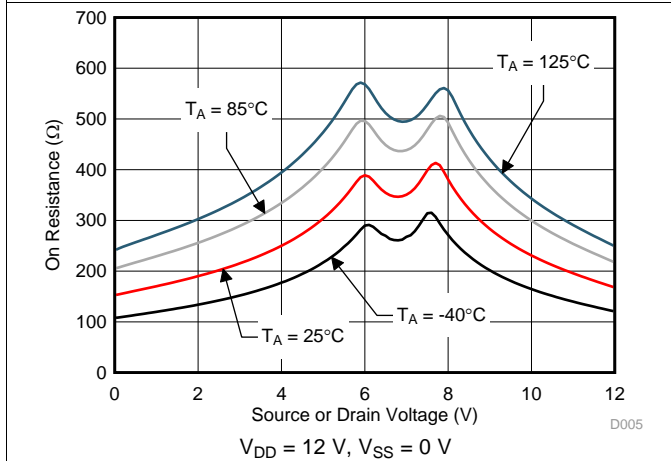

图 7. Leakage Current vs Temperature

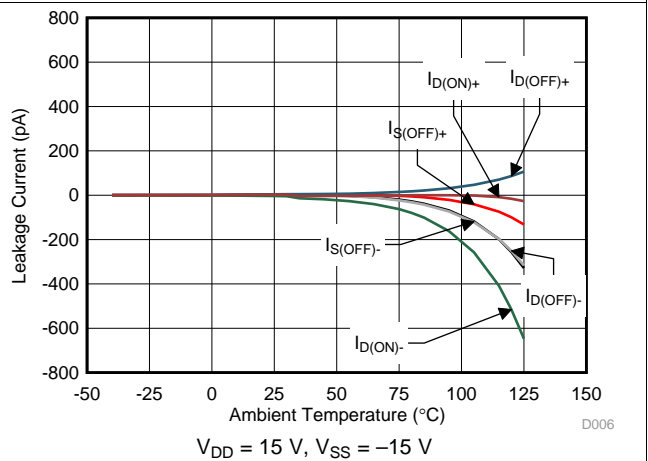

图 8. Charge Injection vs Source Voltage

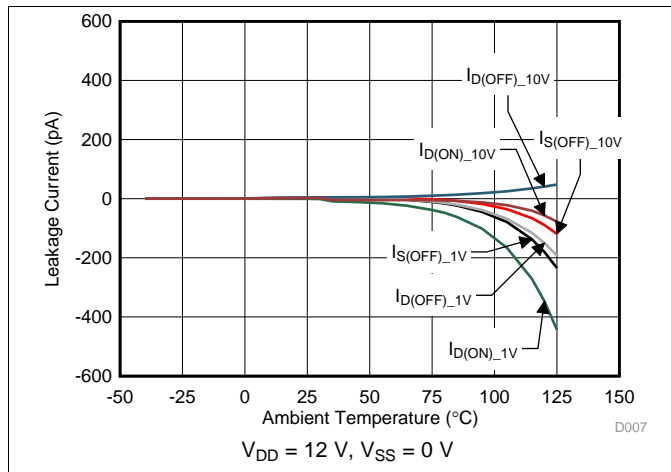

图 9. Charge Injection vs Drain Voltage

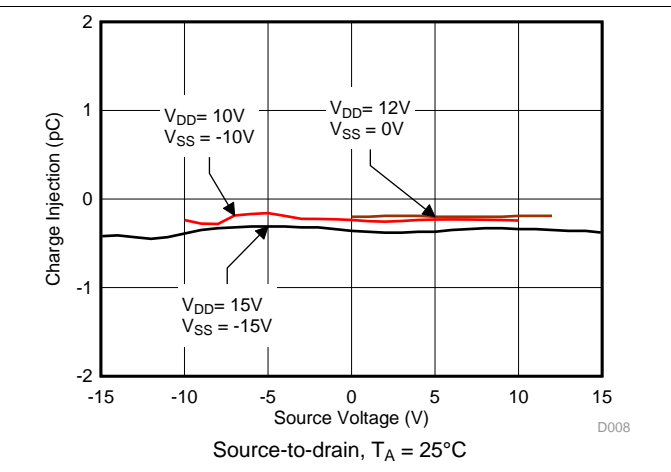

图 10. Turn-On and Turn-Off Times vs Temperature

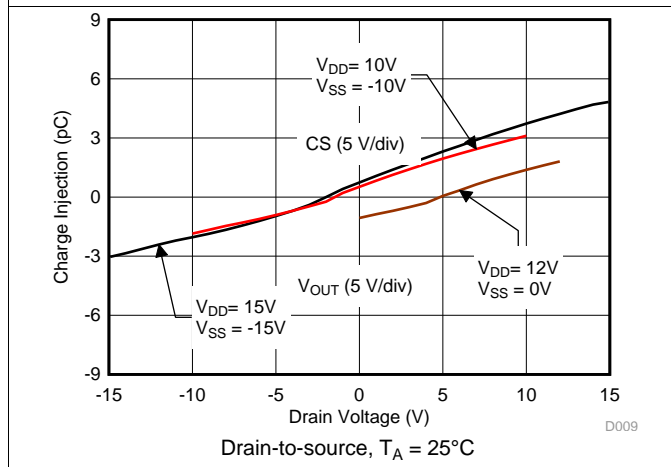

图 11. Off Isolation vs Frequency

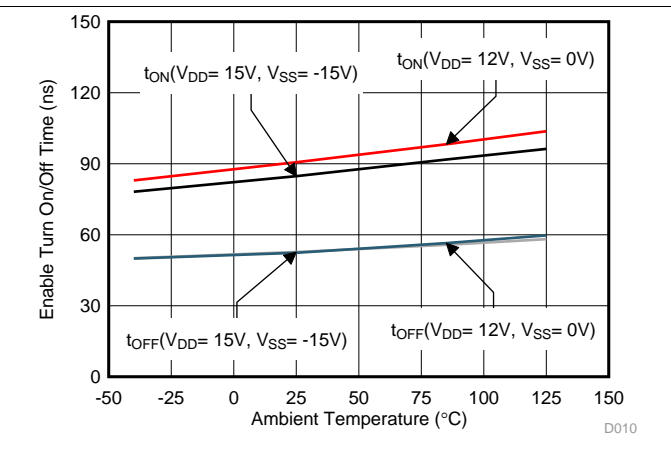

图 12. Crosstalk vs Frequency

Typical Characteristics (接下页)

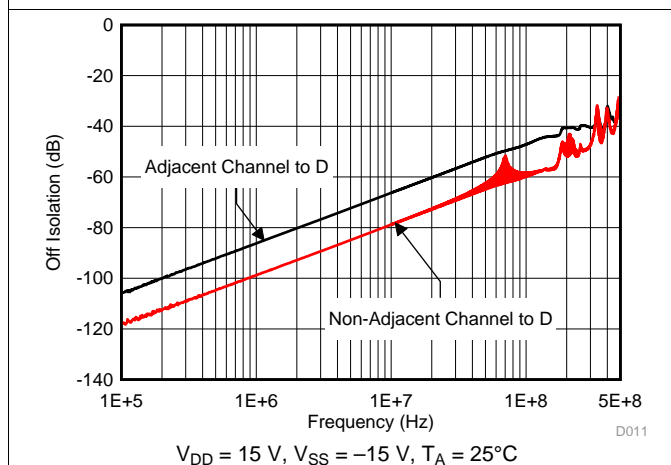

图 13. THD+N vs Frequency

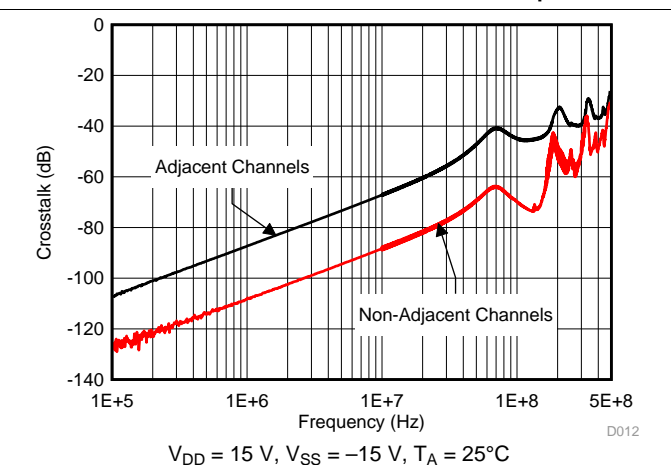

图 14. On Response vs. Frequency

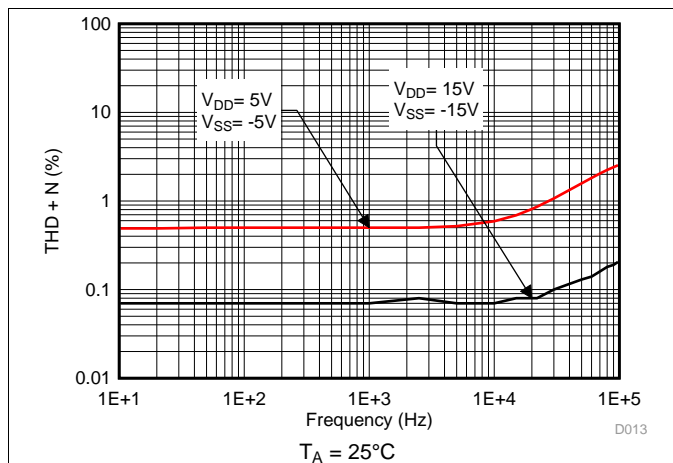

图 15. Capacitance vs Source Voltage

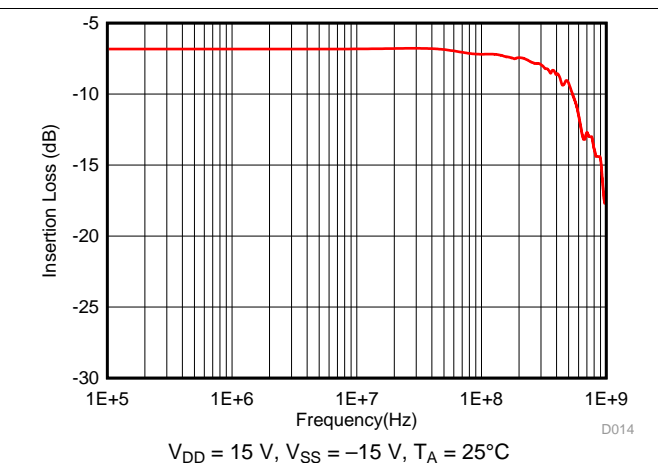

图 16. Capacitance vs Source Voltage

7 Parameter Measurement Information

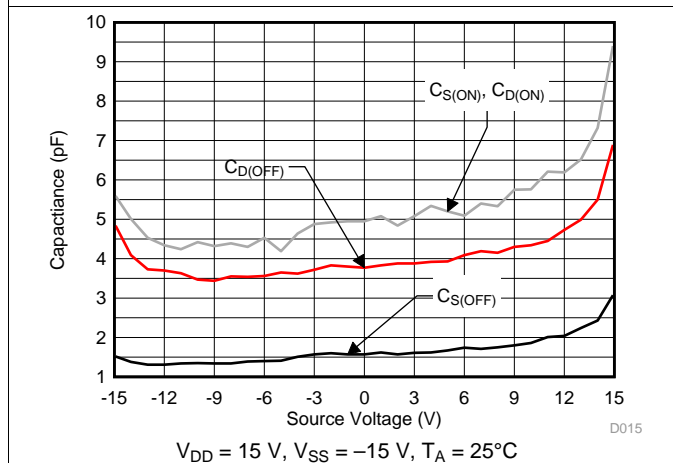
7.1 Truth Table

表 1. TMUX6104 Truth Table

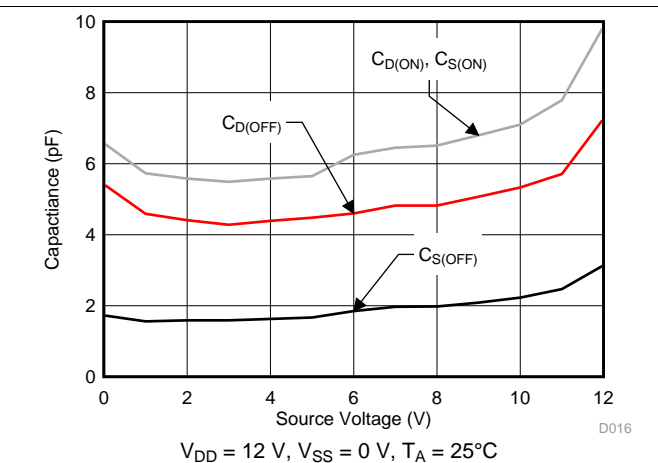
EN	A1	A0	STATE
0	X ⁽¹⁾	X ⁽¹⁾	All channels are off
1	0	0	Channel 1
1	0	1	Channel 2
1	1	0	Channel 3
1	1	1	Channel 4

(1) X denotes don't care..

8 Detailed Description

8.1 Overview

8.1.1 On-Resistance

The on-resistance of the TMUX6104 is the ohmic resistance across the source (Sx) and drain (D) pins of the device. The on-resistance varies with input voltage and supply voltage. The symbol R_{ON} is used to denote on-resistance. The measurement setup used to measure R_{ON} is shown in 图 17. Voltage (V) and current (I_{CH}) are measured using this setup, and R_{ON} is computed as shown in 公式 1:



图 17. On-Resistance Measurement Setup

$$R_{ON} = V / I_{CH} \quad (1)$$

8.1.2 Off-Leakage Current

There are two types of leakage currents associated with a switch during the off state:

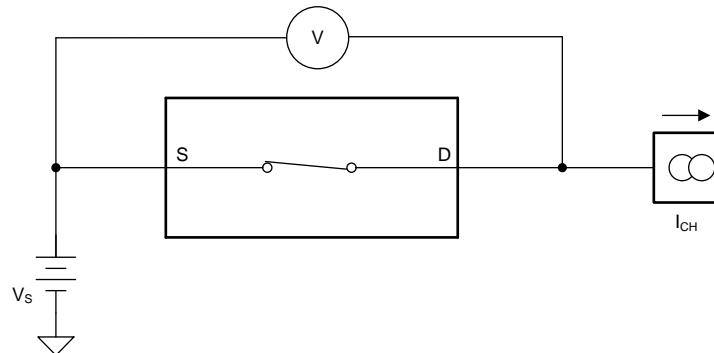
1. Source off-leakage current
2. Drain off-leakage current

Source leakage current is defined as the leakage current flowing into or out of the source pin when the switch is off. This current is denoted by the symbol $I_{S(OFF)}$.

Drain leakage current is defined as the leakage current flowing into or out of the drain pin when the switch is off. This current is denoted by the symbol $I_{D(OFF)}$.

The setup used to measure both off-leakage currents is shown in 图 18



图 18. Off-Leakage Measurement Setup

Overview (接下页)

8.1.3 On-Leakage Current

On-leakage current is defined as the leakage current that flows into or out of the drain pin when the switch is in the on state. The source pin is left floating during the measurement. 图 19 shows the circuit used for measuring the on-leakage current, denoted by $I_{D(ON)}$.

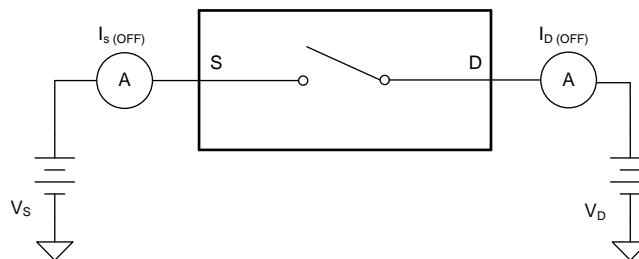

图 19. On-Leakage Measurement Setup

8.1.4 Transition Time

Transition time is defined as the time taken by the output of the TMUX6104 to rise (to 90% of the transition) or fall (to 10% of the transition) after the digital address signal has fallen or risen to 50% of the transition. 图 20 shows the setup used to measure transition time, denoted by the symbol t_{TRAN} .

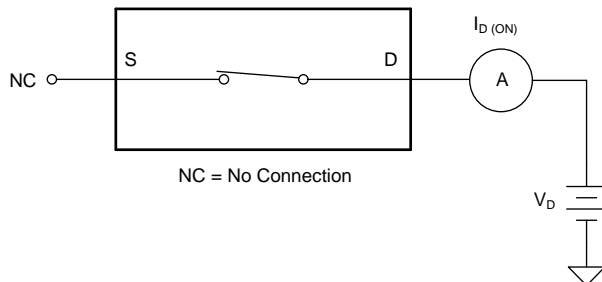

图 20. Transition-Time Measurement Setup

Overview (接下页)

8.1.5 Break-Before-Make Delay

Break-before-make delay is a safety feature that prevents two inputs from connecting when the TMUX6104 is switching. The TMUX6104 output first breaks from the on-state switch before making the connection with the next on-state switch. The time delay between the *break* and the *make* is known as break-before-make delay. 图 21 shows the setup used to measure break-before-make delay, denoted by the symbol t_{BBM} .

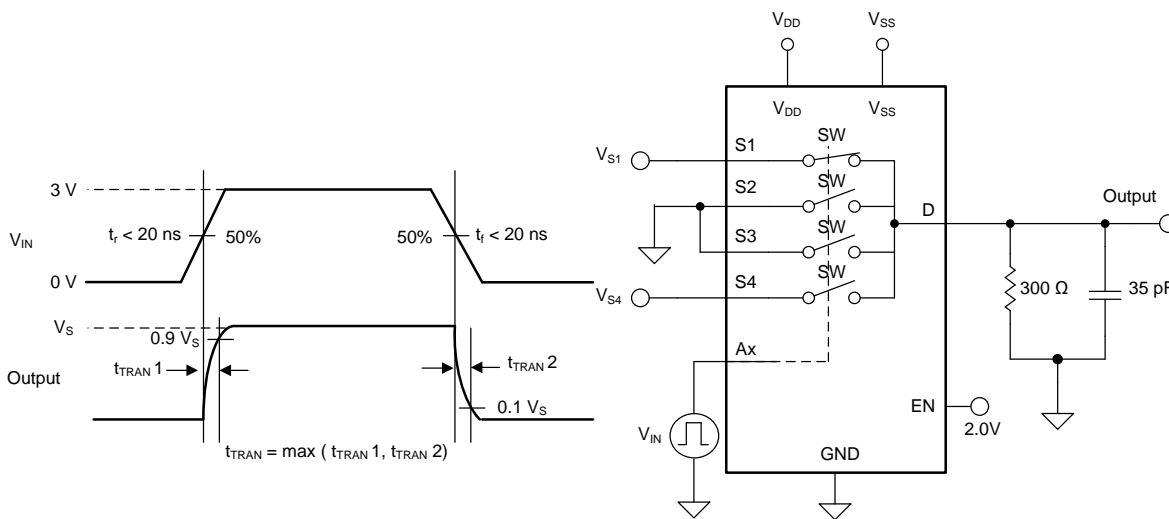

图 21. Break-Before-Make Delay Measurement Setup

8.1.6 Turn-On and Turn-Off Time

Turn-on time is defined as the time taken by the output of the TMUX6104 to rise to a 90% final value after the enable signal has risen to a 50% final value. 图 22 shows the setup used to measure turn-on time. Turn-on time is denoted by the symbol $t_{ON (EN)}$.

Turn off time is defined as the time taken by the output of the TMUX6104 to fall to a 10% initial value after the enable signal has fallen to a 50% initial value. 图 22 shows the setup used to measure turn-off time. Turn-off time is denoted by the symbol $t_{OFF (EN)}$.

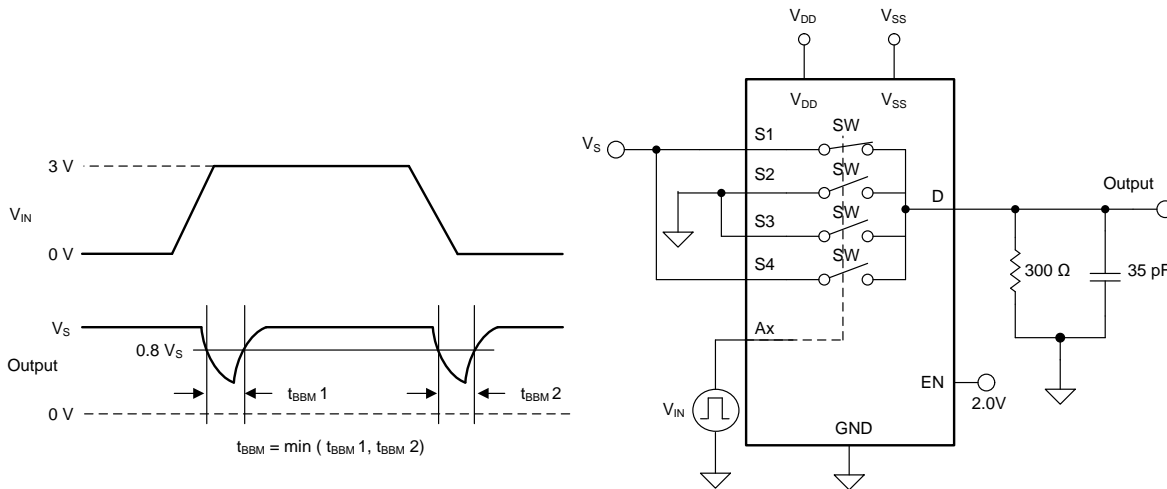

图 22. Turn-On and Turn-Off Time Measurement Setup

Overview (接下页)

8.1.7 Charge Injection

The TMUX6104 have a simple transmission-gate topology. Any mismatch in capacitance between the NMOS and PMOS transistors results in a charge injected into the drain or source during the falling or rising edge of the gate signal. The amount of charge injected into the source or drain of the device is known as charge injection, and is denoted by the symbol Q_{INJ} . 图 23 shows the setup used to measure charge injection from source (Sx) to drain (D).

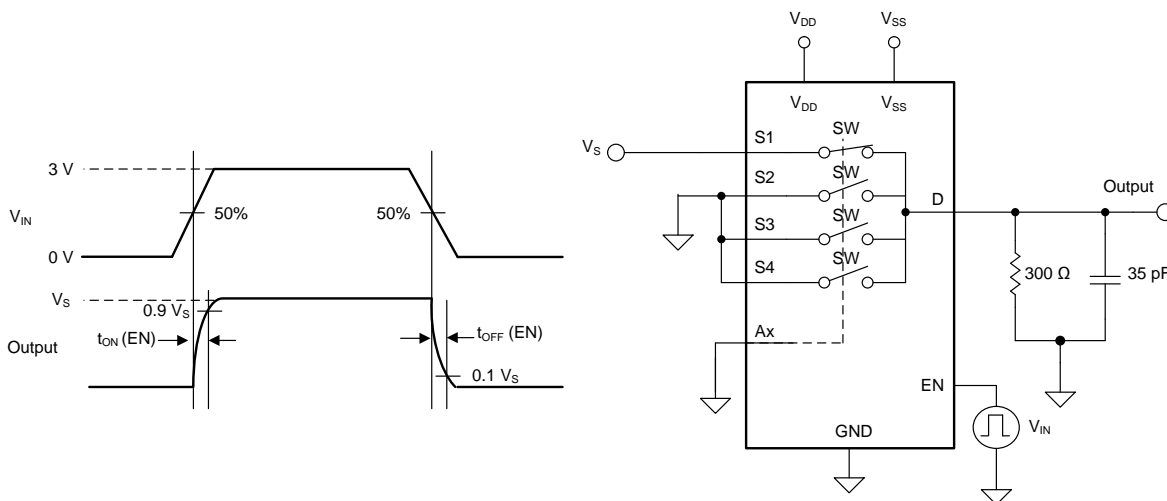

图 23. Charge-Injection Measurement Setup

8.1.8 Off Isolation

Off isolation is defined as the voltage at the drain pin (D) of the TMUX6104 when a 1- V_{RMS} signal is applied to the source pin (Sx) of an off-channel. 图 24 shows the setup used to measure off isolation. Use 公式 2 to compute off isolation.

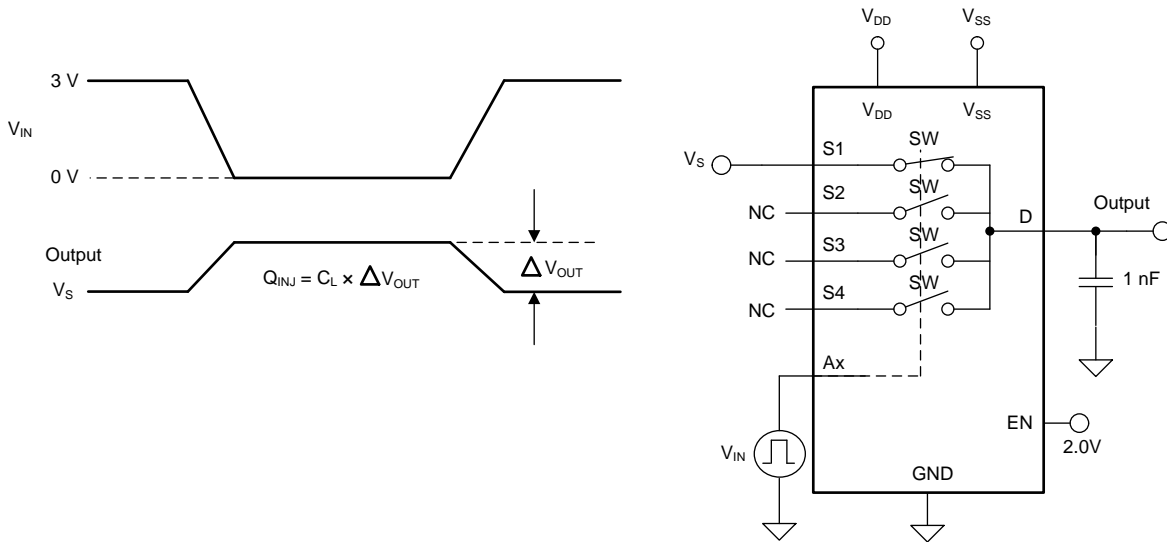

图 24. Off Isolation Measurement Setup

$$\text{Off Isolation} = 20 \cdot \text{Log} \left(\frac{V_{OUT}}{V_S} \right)$$

(2)

Overview (接下页)

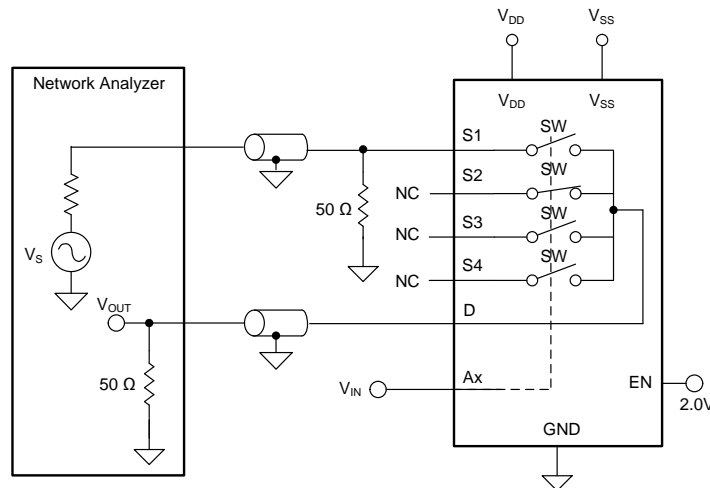
8.1.9 Channel-to-Channel Crosstalk

Channel-to-channel crosstalk is defined as the voltage at the source pin (Sx) of an off-channel, when a 1- V_{RMS} signal is applied at the source pin (Sx) of an on-channel. 图 25 shows the setup used to measure, and 公式 3 is the equation used to compute, channel-to-channel crosstalk.



图 25. Channel-to-Channel Crosstalk Measurement Setup

$$\text{Channel-to-Channel Crosstalk} = 20 \cdot \text{Log} \left(\frac{V_{OUT}}{V_S} \right) \tag{3}$$

8.1.10 Bandwidth

Bandwidth is defined as the range of frequencies that are attenuated by < 3 dB when the input is applied to the source pin (Sx) of an on-channel, and the output is measured at the drain pin (D) of the TMUX6104. 图 26 shows the setup used to measure bandwidth of the mux. Use 公式 4 to compute the attenuation.

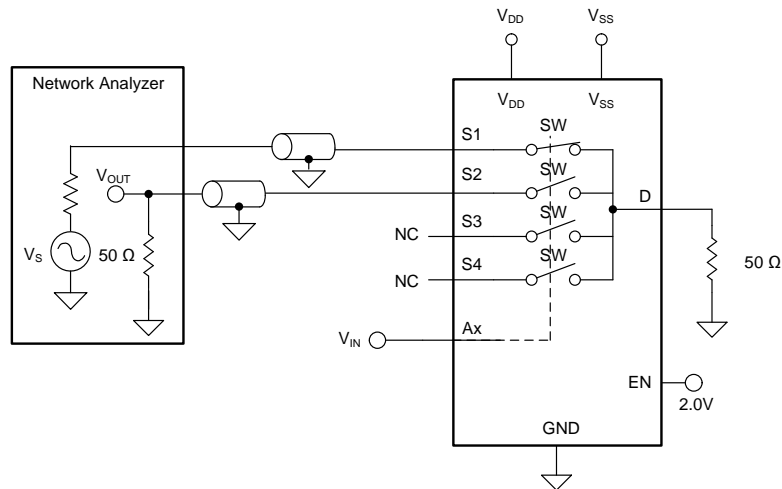

图 26. Bandwidth Measurement Setup

$$\text{Attenuation} = 20 \times \text{Log} \left(\frac{V_{OUT}}{V_S} \right) \tag{4}$$

Overview (接下页)

8.1.11 THD + Noise

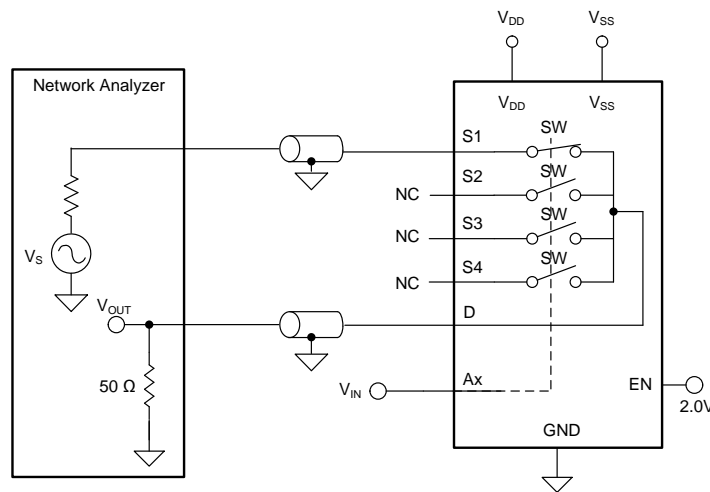
The total harmonic distortion (THD) of a signal is a measurement of the harmonic distortion, and is defined as the ratio of the sum of the powers of all harmonic components to the power of the fundamental frequency at the mux output. The on-resistance of the TMUX6104 varies with the amplitude of the input signal and results in distortion when the drain pin is connected to a low-impedance load. Total harmonic distortion plus noise is denoted as THD+N.



图 27. THD+N Measurement Setup

8.1.12 AC Power Supply Rejection Ratio (AC PSRR)

AC PSRR measures the ability of a device to prevent noise and spurious signals that appear on the supply voltage pin from coupling to the output of the switch. The DC voltage on the device supply is modulated by a sine wave of 620 mV_{PP}. The ratio of the amplitude of signal on the output to the amplitude of the modulated signal is the AC PSRR.

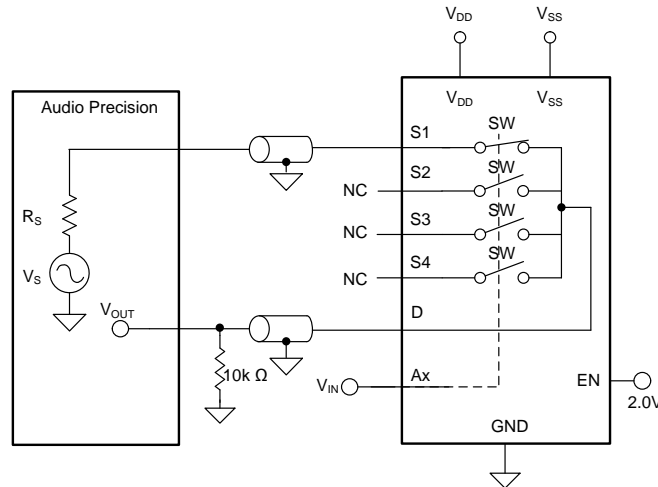

图 28. AC PSRR Measurement Setup

Overview (接下页)

The [Functional Block Diagram](#) section provides a top-level block diagram of the TMUX6104. The TMUX6104 is a 4-channel, single-ended, analog multiplexer. Each channel is turned on or turned off based on the state of the address lines and enable pin.

8.2 Functional Block Diagram

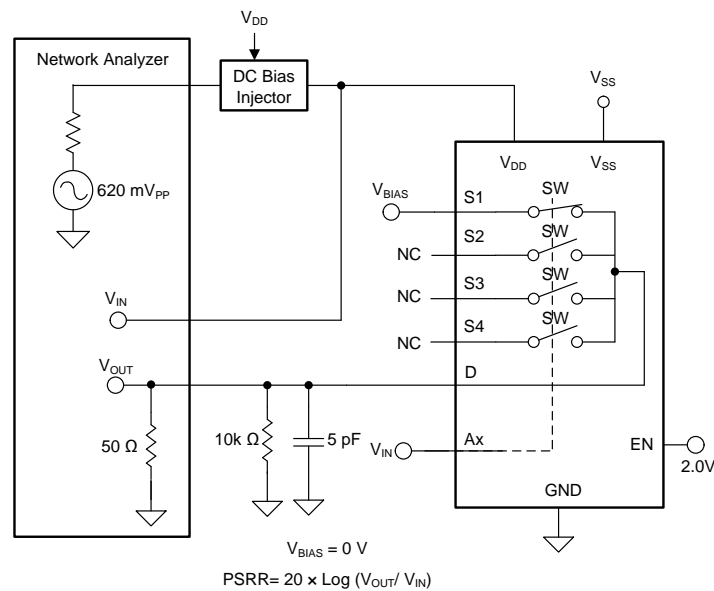
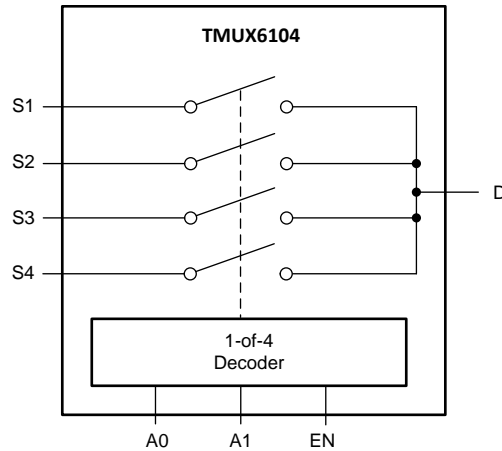

Copyright © 2017, Texas Instruments Incorporated

8.3 Feature Description

8.3.1 Ultralow Leakage Current

The TMUX6104 provide extremely low on- and off-leakage currents. The TMUX6104 is capable of switching signals from high source-impedance inputs into a high input-impedance op amp with minimal offset error because of the ultralow leakage currents. [图 29](#) shows typical leakage currents of the TMUX6104 versus temperature.



图 29. Leakage Current vs Temperature

8.3.2 Ultralow Charge Injection

The TMUX6104 is implemented with simple transmission gate topology, as shown in [图 30](#). Any mismatch in the stray capacitance associated with the NMOS and PMOS causes an output level change whenever the switch is opened or closed.

Feature Description (接下页)

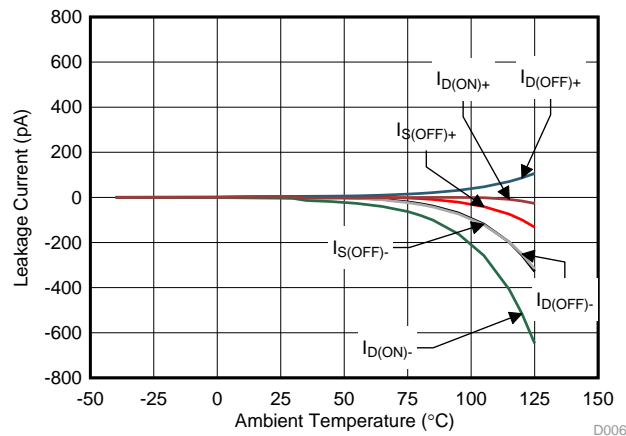

图 30. Transmission Gate Topology

The TMUX6119 utilizes special charge-injection cancellation circuitry that reduces the source (Sx) to drain (D) charge injection to as low as -0.35 pC at $V_S = 0$ V, and -0.41 pC in the full signal range, as shown in 图 31.

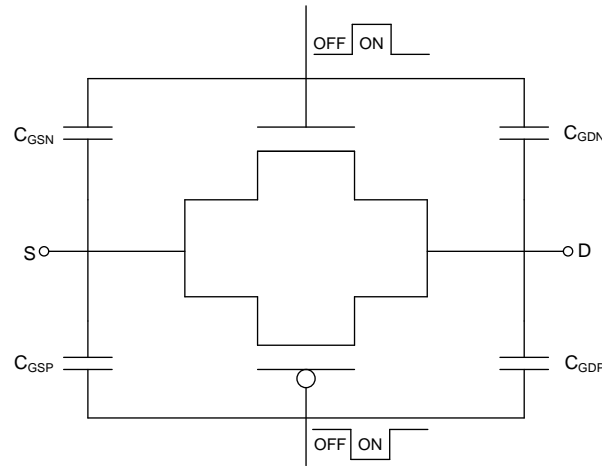

图 31. Source-to-Drain Charge Injection vs Source Voltage

The drain (D)-to-source (Sx) charge injection becomes important when the device is used as a demultiplexer (demux), where the drain (D) becomes the input and the source (Sx) becomes the output. 图 32 shows the drain-to-source charge injection across the full signal range.

Feature Description (接下页)

图 32. Drain-to-Source Charge Injection vs Drain Voltage
8.3.3 Bidirectional and Rail-to-Rail Operation

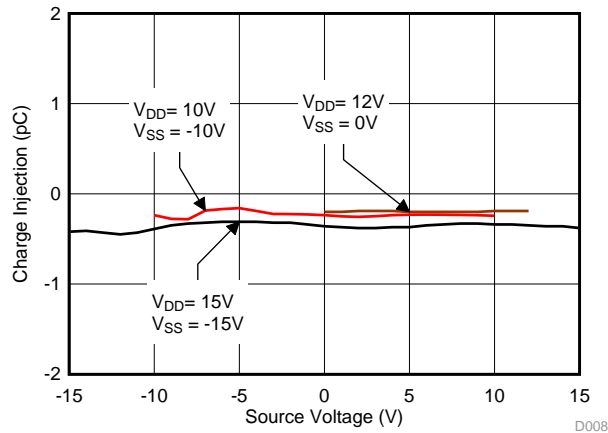
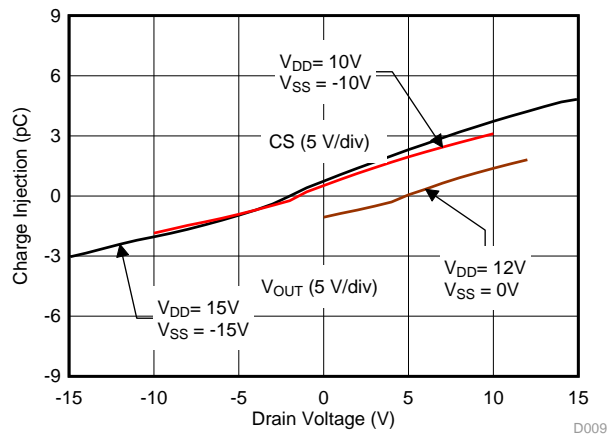
The TMUX6104 conducts equally well from source (Sx) to drain (D) or from drain (D) to source (Sx). Each TMUX6104 channel has very similar characteristics in both directions. The valid analog signal for TMUX6104 ranges from V_{SS} to V_{DD} . The input signal to the TMUX6104 swings from V_{SS} to V_{DD} without any significant degradation in performance.

8.4 Device Functional Modes

When the EN pin of the TMUX6104 is pulled high, one of the four switches is closed based on the state of the address pins (A0 and A1). When the EN pin is pulled low, all four switches remain open irrespective of the state of the address pins. The EN pin is weakly pull-down internally through a 6 M Ω resistor; thereby, setting each channel to the open state if the EN pin is not actively driven. The address pins are also weakly pulled-down through an internal 6 M Ω resistor, allowing channel 1 (S1 to D) to be selected by default when EN pin is driven high. Both the EN pin and the address pins can be connected to V_{DD} (as high as 16.5 V).

9 Application and Implementation

注

Information in the following applications sections is not part of the TI component specification, and TI does not warrant its accuracy or completeness. TI's customers are responsible for determining suitability of components for their purposes. Customers should validate and test their design implementation to confirm system functionality.

9.1 Application Information

The TMUX6104 offers outstanding input/output leakage currents and ultralow charge injection. These devices operate up to 33 V, and offer true rail-to-rail input and output. The on-capacitance of the TMUX6104 is very low. These features makes the TMUX6104 a precision, robust, high-performance analog multiplexer for high-voltage, industrial applications.

9.2 Typical Application

图 33 shows a 16-bit, differential, 4-channel, multiplexed, data-acquisition system. This example is typical in industrial applications that require low distortion and a high-voltage input. The circuit uses the ADS8864, a 16-bit, 400-kSPS successive-approximation-resistor (SAR) analog-to-digital converter (ADC), along with a precision, high-voltage, signal-conditioning front end, and a 4-channel single-ended mux. This TI Precision Design details the process for optimizing the precision, high-voltage, front-end drive circuit using the TMUX6104 and OPA192 to achieve excellent dynamic performance and linearity with the ADS8864.

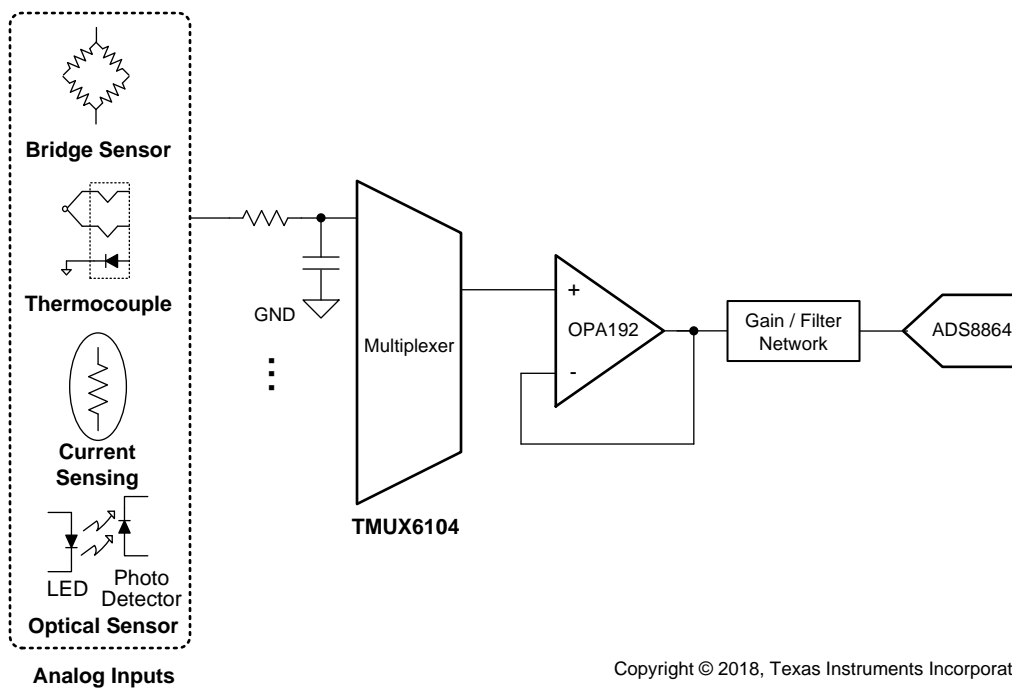

Copyright © 2018, Texas Instruments Incorporated

图 33. 16-Bit Precision Multiplexed Data-Acquisition System for High-Voltage Inputs With Lowest Distortion

Typical Application (接下页)

9.2.1 Design Requirements

The primary objective is to design a ± 15 V, single-ended, 4-channel, multiplexed, data-acquisition system with lowest distortion using the 16-bit ADS8864 at a throughput of 400 kSPS for a 10-kHz, full-scale, pure, sine-wave input. The design requirements for this block design are:

- System supply voltage: ± 15 V
- ADC supply voltage: 3.3 V
- ADC sampling rate: 400 kSPS
- ADC reference voltage (REFP): 4.096 V
- System input signal: A high-voltage differential input signal with a peak amplitude of 15 V and frequency (f_{IN}) of 10 kHz are applied to each differential input of the mux.

9.2.2 Detailed Design Procedure

The purpose of this precision design is to design an optimal, high-voltage, multiplexed, data-acquisition system for highest system linearity and fast settling. The overall system block diagram is illustrated in 图 33. The circuit is a multichannel, data-acquisition signal chain consisting of an input low-pass filter, mux, mux output buffer, and attenuating SAR ADC driver. The architecture allows fast sampling of multiple channels using a single ADC, providing a low-cost solution. This design systematically approaches each analog circuit block to achieve a 16-bit settling for a full-scale input stage voltage and linearity for a 10-kHz sinusoidal input signal at each input channel.

9.2.3 Application Curve



图 34. ADC 16-Bit Linearity Error for the Multiplexed Data-Acquisition Block

10 Power Supply Recommendations

The TMUX6104 operates across a wide supply range of ± 5 V to ± 16.5 V (10 V to 16.5 V in single-supply mode). The device also perform well with unsymmetric supplies such as $V_{DD} = 12$ V and $V_{SS} = -5$ V. For reliable operation, use a supply decoupling capacitor ranging between 0.1 μ F to 10 μ F at both the V_{DD} and V_{SS} pins to ground.

The on-resistance of the TMUX6104 varies with supply voltage, as illustrated in [图 35](#)

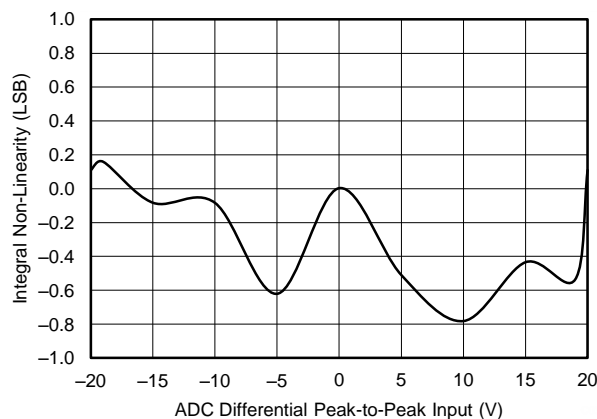

图 35. On-Resistance Variation With Supply and Input Voltage

11 Layout

11.1 Layout Guidelines

图 36 illustrates an example of a PCB layout with the TMUX6104.

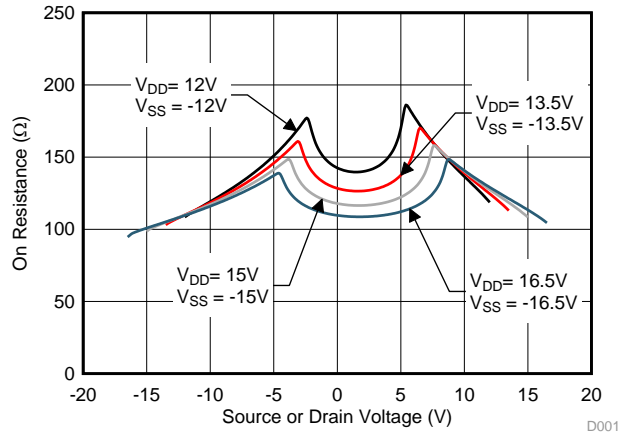
Some key considerations are:

1. Decouple the V_{DD} and V_{SS} pins with a 0.1- μF capacitor, placed as close to the pin as possible. Make sure that the capacitor voltage rating is sufficient for the V_{DD} and V_{SS} supplies.
2. Keep the input lines as short as possible.
3. Use a solid ground plane to help distribute heat and reduce electromagnetic interference (EMI) noise pickup.
4. Do not run sensitive analog traces in parallel with digital traces. Avoid crossing digital and analog traces if possible, and only make perpendicular crossings when necessary.

11.2 Layout Example

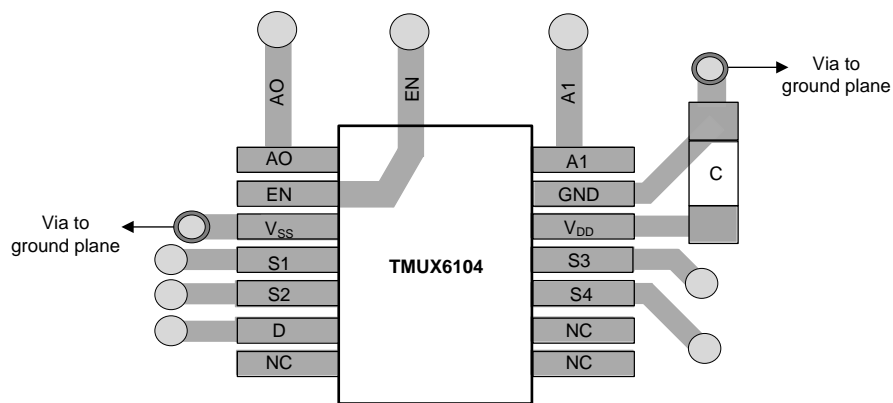

Copyright © 2018, Texas Instruments Incorporated

图 36. TMUX6104 Layout Example

12 器件和文档支持

12.1 文档支持

12.1.1 相关文档

- 《支持双极输入范围的 [ADS8664](#) 12 位、500kSPS、4 通道和 8 通道单电源 SAR ADC》(SBAS492)
- 《采用 [e-Trim™](#) 技术的 [OPA192](#) 36V、轨至轨输入/输出、低失调电压、低输入偏置电流运算放大器》(SBOS620)

12.2 接收文档更新通知

要接收文档更新通知，请导航至 TI.com.cn 上的器件产品文件夹。单击右上角的 [通知我](#) 进行注册，即可每周接收产品信息更改摘要。有关更改的详细信息，请查看任何已修订文档中包含的修订历史记录。

12.3 社区资源

下列链接提供到 TI 社区资源的连接。链接的内容由各个分销商“按照原样”提供。这些内容并不构成 TI 技术规范，并且不一定反映 TI 的观点；请参阅 TI 的《[使用条款](#)》。

TI E2E™ 在线社区 [TI 的工程师对工程师 \(E2E\) 社区](#)。此社区的创建目的在于促进工程师之间的协作。在 e2e.ti.com 中，您可以咨询问题、分享知识、拓展思路并与同行工程师一道帮助解决问题。

设计支持 [TI 参考设计支持](#) 可帮助您快速查找有帮助的 E2E 论坛、设计支持工具以及技术支持的联系信息。

12.4 商标

E2E is a trademark of Texas Instruments.

All other trademarks are the property of their respective owners.

12.5 静电放电警告



ESD 可能会损坏该集成电路。德州仪器 (TI) 建议通过适当的预防措施处理所有集成电路。如果不遵守正确的处理措施和安装程序，可能会损坏集成电路。

ESD 的损坏小至导致微小的性能降级，大至整个器件故障。精密的集成电路可能更容易受到损坏，这是因为非常细微的参数更改都可能会导致器件与其发布的规格不相符。

12.6 术语表

[SLYZ022](#) — TI 术语表。

这份术语表列出并解释术语、缩写和定义。

13 机械、封装和可订购信息

以下页面包含机械、封装和可订购信息。这些信息是指定器件的最新可用数据。数据如有变更，恕不另行通知，且不会对此文档进行修订。如需获取此数据表的浏览器版本，请查阅左侧的导航栏。

PACKAGING INFORMATION

Orderable Device	Status (1)	Package Type	Package Drawing	Pins	Package Qty	Eco Plan (2)	Lead finish/ Ball material (6)	MSL Peak Temp (3)	Op Temp (°C)	Device Marking (4/5)	Samples
TMUX6104PWR	ACTIVE	TSSOP	PW	14	2000	RoHS & Green	NIPDAU	Level-1-260C-UNLIM	-40 to 125	MUX6104	Samples

(1) The marketing status values are defined as follows:

ACTIVE: Product device recommended for new designs.

LIFEBUY: TI has announced that the device will be discontinued, and a lifetime-buy period is in effect.

NRND: Not recommended for new designs. Device is in production to support existing customers, but TI does not recommend using this part in a new design.

PREVIEW: Device has been announced but is not in production. Samples may or may not be available.

OBSOLETE: TI has discontinued the production of the device.

(2) **RoHS:** TI defines "RoHS" to mean semiconductor products that are compliant with the current EU RoHS requirements for all 10 RoHS substances, including the requirement that RoHS substance do not exceed 0.1% by weight in homogeneous materials. Where designed to be soldered at high temperatures, "RoHS" products are suitable for use in specified lead-free processes. TI may reference these types of products as "Pb-Free".

RoHS Exempt: TI defines "RoHS Exempt" to mean products that contain lead but are compliant with EU RoHS pursuant to a specific EU RoHS exemption.

Green: TI defines "Green" to mean the content of Chlorine (Cl) and Bromine (Br) based flame retardants meet JS709B low halogen requirements of <=1000ppm threshold. Antimony trioxide based flame retardants must also meet the <=1000ppm threshold requirement.

(3) MSL, Peak Temp. - The Moisture Sensitivity Level rating according to the JEDEC industry standard classifications, and peak solder temperature.

(4) There may be additional marking, which relates to the logo, the lot trace code information, or the environmental category on the device.

(5) Multiple Device Markings will be inside parentheses. Only one Device Marking contained in parentheses and separated by a "-" will appear on a device. If a line is indented then it is a continuation of the previous line and the two combined represent the entire Device Marking for that device.

(6) Lead finish/Ball material - Orderable Devices may have multiple material finish options. Finish options are separated by a vertical ruled line. Lead finish/Ball material values may wrap to two lines if the finish value exceeds the maximum column width.

Important Information and Disclaimer: The information provided on this page represents TI's knowledge and belief as of the date that it is provided. TI bases its knowledge and belief on information provided by third parties, and makes no representation or warranty as to the accuracy of such information. Efforts are underway to better integrate information from third parties. TI has taken and continues to take reasonable steps to provide representative and accurate information but may not have conducted destructive testing or chemical analysis on incoming materials and chemicals. TI and TI suppliers consider certain information to be proprietary, and thus CAS numbers and other limited information may not be available for release.

In no event shall TI's liability arising out of such information exceed the total purchase price of the TI part(s) at issue in this document sold by TI to Customer on an annual basis.

TAPE AND REEL INFORMATION

QUADRANT ASSIGNMENTS FOR PIN 1 ORIENTATION IN TAPE

*All dimensions are nominal

Device	Package Type	Package Drawing	Pins	SPQ	Reel Diameter (mm)	Reel Width W1 (mm)	A0 (mm)	B0 (mm)	K0 (mm)	P1 (mm)	W (mm)	Pin1 Quadrant
TMUX6104PWR	TSSOP	PW	14	2000	330.0	12.4	6.9	5.6	1.6	8.0	12.0	Q1

TAPE AND REEL BOX DIMENSIONS

*All dimensions are nominal

Device	Package Type	Package Drawing	Pins	SPQ	Length (mm)	Width (mm)	Height (mm)
TMUX6104PWR	TSSOP	PW	14	2000	356.0	356.0	35.0

PW (R-PDSO-G14)

PLASTIC SMALL OUTLINE



4040064-3/G 02/11

- NOTES:
- A. All linear dimensions are in millimeters. Dimensioning and tolerancing per ASME Y14.5M-1994.
 - B. This drawing is subject to change without notice.
 - C. Body length does not include mold flash, protrusions, or gate burrs. Mold flash, protrusions, or gate burrs shall not exceed 0,15 each side.
 - D. Body width does not include interlead flash. Interlead flash shall not exceed 0,25 each side.
 - E. Falls within JEDEC MO-153

重要声明和免责声明

TI“按原样”提供技术和可靠性数据（包括数据表）、设计资源（包括参考设计）、应用或其他设计建议、网络工具、安全信息和其他资源，不保证没有瑕疵且不做任何明示或暗示的担保，包括但不限于对适销性、某特定用途方面的适用性或不侵犯任何第三方知识产权的暗示担保。

这些资源可供使用 TI 产品进行设计的熟练开发人员使用。您将自行承担以下全部责任：(1) 针对您的应用选择合适的 TI 产品，(2) 设计、验证并测试您的应用，(3) 确保您的应用满足相应标准以及任何其他功能安全、信息安全、监管或其他要求。

这些资源如有变更，恕不另行通知。TI 授权您仅可将这些资源用于研发本资源所述的 TI 产品的应用。严禁对这些资源进行其他复制或展示。您无权使用任何其他 TI 知识产权或任何第三方知识产权。您应全额赔偿因在这些资源的使用中对 TI 及其代表造成的任何索赔、损害、成本、损失和债务，TI 对此概不负责。

TI 提供的产品受 [TI 的销售条款](#) 或 [ti.com](#) 上其他适用条款/TI 产品随附的其他适用条款的约束。TI 提供这些资源并不会扩展或以其他方式更改 TI 针对 TI 产品发布的适用的担保或担保免责声明。

TI 反对并拒绝您可能提出的任何其他或不同的条款。

邮寄地址：Texas Instruments, Post Office Box 655303, Dallas, Texas 75265

Copyright © 2023，德州仪器 (TI) 公司