

具有系统功率监测器和处理器热量监测器的 bq25703A I2C 多化合物电池 降压/升压充电控制器

1 特性

- 从各种输入源为 1 至 4 节电池充电
 - 3.5V 至 24V 输入工作电压
 - 支持 USB 2.0、USB 3.0、USB 3.1 (Type-C) 和 USB_PD 输入电流设置
 - 在降压和升压操作之间进行无缝转换
 - 提供输入电流和电压调节 (IDPM 和 VDPM) 以防电源过载
- 用于 CPU 节流的功率/电流监控器
 - 综合 PROCHOT 设置, 符合 IMVP8
 - 输入和电池电流监控器
 - 系统功率监控器, 符合 IMVP8
- 窄 VDC (NVDC) 电源路径管理
 - 无需电池或使用深度放电的电池亦可瞬时启动
 - 适配器满载时, 电池可为系统补充电量
- 从电池给 USB 端口加电 (USB OTG)
 - 输出 4.48V 至 20.8V 与 USB PD 兼容
 - 输出电流限制高达 6.35A
- 用于 1 μ H 至 3.3 μ H 电感器的 800kHz 或 1.2MHz 可编程开关频率
- 可通过主机控制接口实现灵活系统配置
 - I2C (bq25703A) 端口用于优化系统性能和状态报告
 - 硬件引脚可用于设置输入电流限制, 无需 EC 控制
- 集成型 ADC 可监控电压、电流和功率
- 高精度调节和监控
 - $\pm 0.5\%$ 充电电压调节
 - $\pm 2\%$ 输入/充电电流调节
 - $\pm 2\%$ 输入/充电电流监控
 - $\pm 5\%$ 功率监控器
- 安全性
 - 热关断
 - 输入、系统、电池过电压保护
 - MOSFET 电感过流保护
- 低电池静态电流

- 输入电流优化器 (ICO) 可获取最大输入功率
- 为任意化学电池充电: Li+, LiFePO₄、镍镉、镍氢、铅酸
- 封装: 32 引脚 4 x 4 WQFN

2 应用

- 无人机、蓝牙扬声器、IP 摄像头、可拆卸电脑、平板电脑和移动电源
- 工业用和医疗用设备
- 带可充电电池的便携式设备

3 说明

bq25703A 是一种同步 NVDC 电池降压/升压充电控制器, 为空间受限的多化合物电池充电应用提供了组件数量少的高效解决方案。

NVDC-1 配置可将系统电压稳定在电池电压范围内, 但不会低于系统最小电压。即便在电池完全放电或被取出时, 系统也仍会继续工作。当负载功率超过输入源额定值时, 电池会进入补电模式并防止系统崩溃。

The bq25703A 从 USB 适配器、高电压 USB PD 源和传统适配器等各种输入源为电池充电。

器件信息 (1)

| 器件型号 | 封装 | 封装尺寸 (标称值) |
|----------|-----------|-----------------|
| bq25703A | WQFN (32) | 4.00mm x 4.00mm |

(1) 如需了解所有可用封装, 请参阅产品说明书末尾的可订购产品附录。

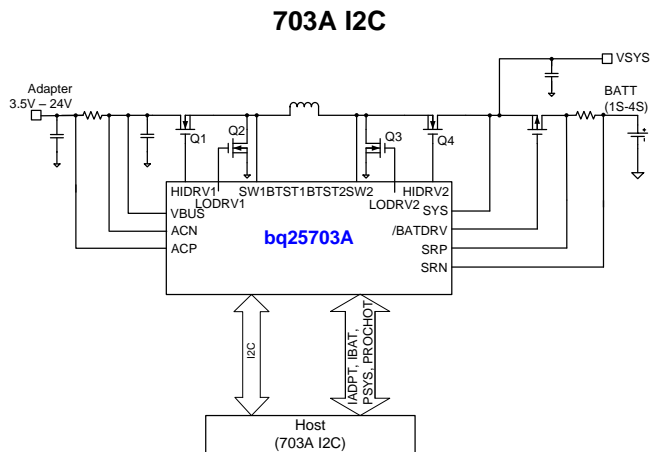

目录

| | |
|--|---|
| <p>1 特性 1</p> <p>2 应用 1</p> <p>3 说明 1</p> <p>4 修订历史记录 2</p> <p>5 说明 (续) 5</p> <p>6 Pin Configuration and Functions 6</p> <p>7 Specifications 9</p> <p> 7.1 Absolute Maximum Ratings 9</p> <p> 7.2 ESD Ratings 9</p> <p> 7.3 Recommended Operating Conditions 9</p> <p> 7.4 Thermal Information 10</p> <p> 7.5 Electrical Characteristics 10</p> <p> 7.6 Timing Requirements 18</p> <p> 7.7 Typical Characteristics 19</p> <p>8 Detailed Description 22</p> <p> 8.1 Overview 22</p> <p> 8.2 Functional Block Diagram 23</p> <p> 8.3 Feature Description 24</p> <p> 8.4 Device Functional Modes 30</p> | <p>8.5 Programming 31</p> <p>8.6 Register Map 34</p> <p>9 Application and Implementation 68</p> <p> 9.1 Application Information 68</p> <p> 9.2 Typical Application 68</p> <p>10 Power Supply Recommendations 75</p> <p>11 Layout 76</p> <p> 11.1 Layout Guidelines 76</p> <p> 11.2 Layout Example 76</p> <p>12 器件和文档支持 78</p> <p> 12.1 器件支持 78</p> <p> 12.2 文档支持 78</p> <p> 12.3 接收文档更新通知 78</p> <p> 12.4 社区资源 78</p> <p> 12.5 商标 78</p> <p> 12.6 静电放电警告 78</p> <p> 12.7 术语表 78</p> <p>13 机械、封装和可订购信息 79</p> <p> 13.1 Package Option Addendum 80</p> |
|--|---|

4 修订历史记录

注：之前版本的页码可能与当前版本有所不同。

| Changes from Original (May 2017) to Revision A | Page |
|--|------|
| • 已删除 删除了“特性”中补电模式下的理想二极管 运行 1 | 1 |
| • 已更改 将 2.2 μ H 改为 3.3 μ H 并删除了“特性”中的 低厚度 1 | 1 |
| • 已添加 在“特性”中增加了可监控电压、电流和功率的 集成型 ADC 1 | 1 |
| • 已添加 在“应用”中增加了可拆卸电脑、平板电脑和 移动电源 1 | 1 |
| • 已更改 将“说明”中的输入源从“过载”改为 防止系统崩溃” 1 | 1 |
| • 已更改 在“应用图表”中将 703 I2C 改为 703A I2C 1 | 1 |
| • Changed 18.5 V for 3-cell to 19.5 V for 3-cell and 4-cell in CELL_BATPRESZ description 6 | 6 |
| • Changed I to O for CMPOUT I/O 7 | 7 |
| • Changed $V_{(IADP)}$ to $V_{(IADPT)}$ in IADPT description 7 | 7 |
| • Deleted minimum 10-ms and added minimum to PROCHOT description 7 | 7 |
| • Changed 10- Ω to 10-m Ω in $I_{DPM_REG_ACC}$ in Electrical Characteristics 11 | 11 |
| • Changed 10- Ω to 10-m Ω for $I_{DPM_REG_ACC_ILIM}$ in Electrical Characteristics 11 | 11 |
| • Changed REG0x07/06 to REG0x0B/0A in $V_{DPM_REG_ACC}$ Test Conditions in Electrical Characteristics 12 | 12 |
| • Changed REG0x0B/0A to REG0x07/06 in $V_{OTG_REG_ACC}$ Test Conditions in Electrical Characteristics 12 | 12 |
| • Changed REG0x01[7] = 0 to REG0x01[7] = 1 in Test Conditions for $I_{BAT_BATFET_ON}$ 12 | 12 |
| • Changed I_{BATOV} test condition from: on SRP and SRN to: on VSYS pin 15 | 15 |
| • Changed Q3 to ACX in CONVERTER OVER-CURRENT COMPARATOR (ACX) in Electrical Characteristics 16 | 16 |
| • Added overbar to (BATDRV) in heading 17 | 17 |
| • 已添加 overbar to PROCHOT in Overview 22 | 22 |
| • 已更改 After CHRG_OK goes HIGH to When CHRG_OK goes LOW in Input Voltage and Current Limit Setup 24 | 24 |
| • 已更改 表 1 24 | 24 |
| • 已更改 19.5 to 19.5V in 3S row SYSOVP column in 表 1 24 | 24 |
| • 已更改 0 to 0 A, lowside to low-side, and LSFET turn-on to LSFET turn-on when the HSFET is off in Continuous Conduction Mode (CCM) 25 | 25 |

修订历史记录 (接下页)

| | |
|---|----|
| • 已更改 Pulse Frequency Modulation (PFM) | 25 |
| • 已更改 during forward mode to during forward supplement mode in High-Accuracy Current Sense Amplifier (IADPT and IBAT) | 26 |
| • 已更改 REG0x33[5] to REG0x33[5](EN_PKPWR_IDPM) or REG0x33[4](EN_PKPWR_VSYS) in Two-Level Adapter Current Limit (Peak Power Mode) | 26 |
| • 已添加 last sentence to Two-Level Adapter Current Limit (Peak Power Mode) | 26 |
| • 已更改 Processor Hot Indication | 27 |
| • 已更改 IADP to IADPT in 图 13 | 28 |
| • 已更改 bq2570x to bq2570xA in 图 14 | 29 |
| • 已添加 overbar to PROCHOT in PROCHOT Status | 29 |
| • 已更改 subscript of I_{LIM2_VTH} in Input Overcurrent Protection (ACOC) | 29 |
| • 已更改 bq25700 to bq25703A and 3s – 18.5 V to 3s/4s – 19.5 V in System Overvoltage Protection (SYSOVP) | 30 |
| • 已添加 REG to Battery Charging | 30 |
| • 已更改 The SMBUS address is 12h (0001001_X), where X is the read/write bit. to The I2C address is D6h (1101101_X), where X is the read/write bit. in Programming | 31 |
| • 已添加 h suffix to addresses in ADDR column in 表 4 | 34 |
| • 已更改 0 mA – 6350 mA to 50 mA – 6400 mA for 0F/0Eh in 表 4 | 35 |
| • 已更改 Device Address to DeviceID for 2Fh in 表 4 | 35 |
| • 已更改 I2C address from 01h/00h to 01/00h in 图 23 | 36 |
| • 已更改 bit numbers from 15-8 to 7-0 in 图 23 | 36 |
| • 已添加 <default at POR> to PWM_FREQ description in 表 5 | 37 |
| • 已添加 sentence to IBAT_GAIN description in 表 6 | 37 |
| • 已更改 LDO to internal resistor in EN_LDO description in 表 6 | 37 |
| • 已更改 I2C address from 31h/30h to 31/30h in ChargeOption1 Register (I2C address = 31/30h) [reset = 211h] | 38 |
| • 已更改 bit numbers from 15-8 to 7-0 in 图 24 | 38 |
| • 已删除 Independent Comparator Reference in 表 8 | 38 |
| • 已更改 2.4 V and 1.3 V to 2.3 V and 1.2 V for CMP_REF in 表 8 | 38 |
| • 已删除 Independent Comparator Polarity in 表 8 | 39 |
| • 已删除 Independent Comparator Deglitch Time in 表 8 | 39 |
| • 已添加 independent to FORCE_LATCHOFF description in 表 8 | 39 |
| • 已更改 I2C address from 33h/32h to 33/32h in ChargeOption2 Register (I2C address = 33/32h) [reset = 2B7] | 40 |
| • 已更改 bit numbers from 15-8 to 7-0 in 图 25 | 40 |
| • 已更改 I2C address from 35h/34h to 35/34h in ChargeOption3 Register (I2C address = 35/34h) [reset = 0h] | 42 |
| • 已更改 bit numbers from 15-8 to 7-0 in 图 26 | 42 |
| • 已添加 <default at POR> to BATFETOFF_HIZ description in 表 12 | 42 |
| • 已添加 <default at POR> to PSYS_OTG_IDCHG description in 表 12 | 42 |
| • 已更改 I2C address from 37h/36h to 37/36h in ChargeOption3 Register (I2C address = 35/34h) [reset = 0h] | 43 |
| • 已更改 bit numbers from 15-11 to 7-3, 10-9 to 2-1, 8 to 0 in 图 27 | 43 |
| • 已添加 $\overline{\text{PROCHOT}}$ Pulse Extension Enable to EN_PROCHOT_EXT description in 表 14 | 43 |
| • 已更改 I2C address from 39h/38h to 39/38h in ProchotOption1 Register (I2C address = 39/38h) [reset = 8120h] | 45 |
| • 已更改 bit numbers from 15-10 to 7-2, 9-8 to 1-0 in 图 28 | 45 |
| • 已添加 There is a 128 mA offset. to IDCHG_VTH description in 表 15 | 45 |
| • 已更改 0 mA to 000000b in IDCHG_VTH description in 表 15 | 45 |
| • 已更改 PROCHOT_PROFILE_ACOK description in 表 16 | 46 |
| • 已更改 bit numbers from 15 to 7, 14 to 6, 13 to 5 and 12-8 to 4-0 in 图 29 | 47 |
| • 已更改 bit numbers from 15-8 to 7-0 in 图 30 | 49 |

修订历史记录 (接下页)

| | |
|--|----|
| • 已更改 bit numbers from 15-8 to 7-0 in 图 31 | 51 |
| • 已更改 text in ChargeCurrent Register (I2C address = 03/02h) [reset = 0h] | 52 |
| • 已更改 bit numbers from 15-8 to 7-0 in 图 32 | 52 |
| • 已删除 Upon POR or when charge is disabled, the system is regulated at the MaxChargeVoltage register. from MaxChargeVoltage Register (I2C address = 05/04h) [reset value based on CELL_BATPRESZ pin setting] | 54 |
| • 已更改 bit numbers from 15-8 to 7-0 in 图 33 | 54 |
| • 已更改 bit numbers from 15-8 to 7-0 in 图 34 | 56 |
| • 已删除 text and changed larger to 20-mΩ in Input Current Registers | 57 |
| • 已添加 paragraph to IIN_HOST Register With 10-mΩ Sense Resistor (I2C address = 0F/0Eh) [reset = 4000h] | 58 |
| • 已更改 bit numbers from 15-8 to 7-0 in 图 35 | 58 |
| • 已更改 bit numbers from 15-8 to 7-0 in 图 36 | 59 |
| • 已更改 bit numbers from 15-8 to 7-0 in 图 37 | 60 |
| • 已更改 bit numbers from 15-8 to 7-0 in 图 38 | 61 |
| • 已更改 bit numbers from 15-8 to 7-0 in 图 39 | 62 |
| • 已更改 I2C address to 27/26h in ADCVBUS/PSYS Register (I2C address = 27/26h) | 63 |
| • 已更改 bit numbers from 15-8 to 7-0 in 图 40 | 63 |
| • 已更改 ADCVBUS/PSYS Register Field Descriptions into two tables..... | 63 |
| • 已更改 I2C address to 29/28h in ADCIBAT Register (I2C address = 29/28h) | 64 |
| • 已更改 bit numbers from 15-8 to 7-0 in 图 41 | 64 |
| • 已更改 ADCIBAT Register Field Descriptions into two tables..... | 64 |
| • 已更改 I2C address to 2B/2Ah in ADCIINCMPIN Register (I2C address = 2B/2Ah) | 65 |
| • 已更改 bit numbers from 15-8 to 7-0 in 图 42 | 65 |
| • 已更改 ADCIINCMPIN Register Field Descriptions into two tables..... | 65 |
| • 已更改 I2C address to 2D/2Ch in ADCVSYSVBAT Register (I2C address = 2D/2Ch) | 66 |
| • 已更改 bit numbers from 15-8 to 7-0 in 图 43 | 66 |
| • 已更改 ADCSYSVBAT Register Field Descriptions into two tables..... | 66 |
| • 已更改 bit numbers from 15-8 to 7-0 in 图 44 | 67 |
| • 已删除 15-8, Reserved, and R from 图 45 | 67 |
| • 已删除 15-8, Reserved, and R from 表 48 | 67 |
| • 已更改 图 46 | 68 |
| • 已更改 Minimum System Voltage from 614 mV to 6144 mV in Design Requirements | 69 |
| • 已删除 Input Snubber and Filter for Voltage Spike Damping section | 69 |
| • 已更改 图 47 | 69 |
| • 已添加 Bulk input capacitors should be locate in front of input current sensing resistor. Do not recommend to put bulk input capacitors between input sensing resistor and switching MOSFET. to Input Capacitor | 70 |
| • 已更改 Minimum 4 - 6 pcs of 10-μF 0805 size capacitor is suggested for 45 - 65 W adapter design. to Minimum 10-μF effective capacitance (7 pcs of 10-μF 0805 size capacitor) is suggested for 45 W-65 W adapter. in Input Capacitor .. | 70 |
| • 已更改 Minimum 6 pcs of 10-μF 0805 size capacitor is suggested to be placed by the inductor. to Minimum 10-μF effective capacitance (7 pcs of 10-μF 0805 size capacitor) is suggested to be placed by the inductor, and 50-μF effective distributed capacitance on Vsys output. in Output Capacitor | 70 |

5 说明（续）

在加电期间，充电器基于输入源和电池状况，将转换器设置为降压、升压或降压/升压配置。充电器自动在降压、升压、降压/升压配置间转换，无需主机控制。

在无输入源的情况下，bq25703A 可通过 1 到 4 节电池支持 On-the-Go (OTG) 功能，从而在 VBUS 上生成 4.48V 至 20.8V 电压。在 OTG 模式下，充电器调节输出电压和输出电流。

bq25703A 可监控适配器电流、电池电流和系统功率。灵活编程的 $\overline{\text{PROCHOT}}$ 输出直达 CPU，可根据需要降低其频率。

6 Pin Configuration and Functions

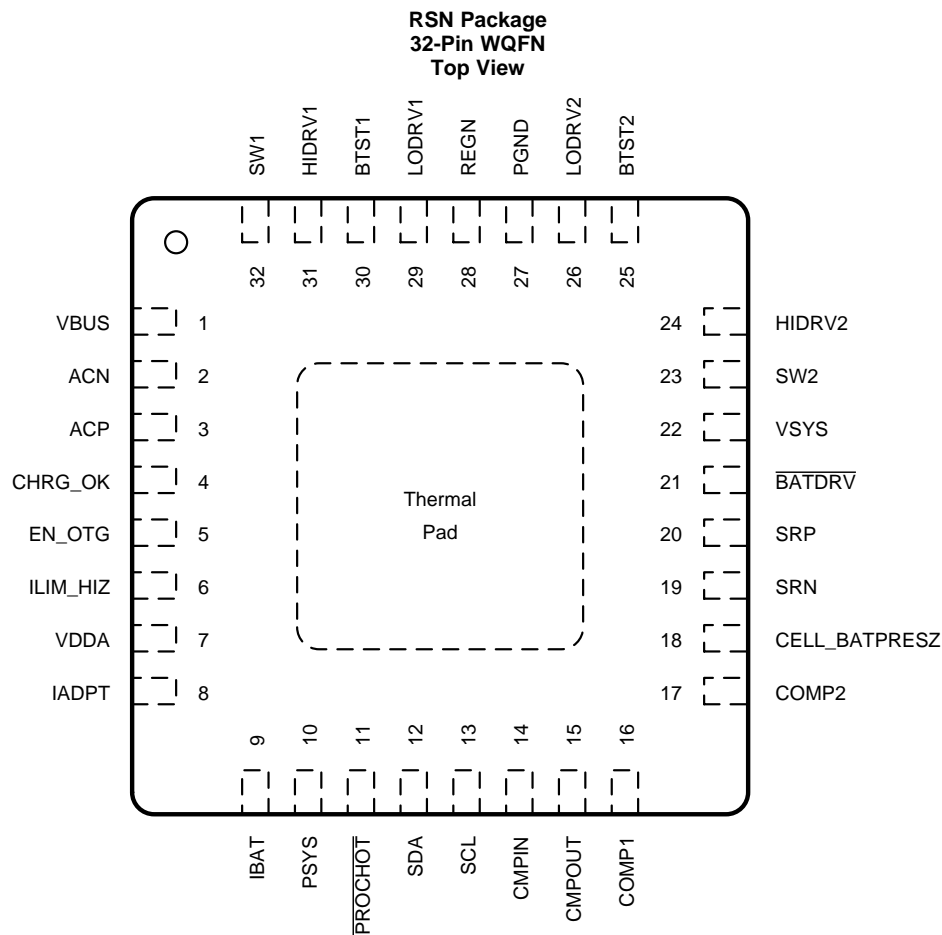

Pin Functions

| PIN | | I/O | DESCRIPTION |
|----------------------------|--------|-----|--|
| NAME | NUMBER | | |
| ACN | 2 | PWR | Input current sense resistor negative input. The leakage on ACP and ACN are matched. The series resistors on the ACP and ACN pins are placed between sense resistor and filter cap. Refer to Application and Implementation for ACP/ACN filter design. |
| ACP | 3 | PWR | Input current sense resistor positive input. The leakage on ACP and ACN are matched. The series resistors on the ACP and ACN pins are placed between sense resistor and filter cap. Refer to Application and Implementation for ACP/ACN filter design. |
| $\overline{\text{BATDRV}}$ | 21 | O | P-channel battery FET (BATFET) gate driver output. It is shorted to VSYS to turn off the BATFET. It goes 10 V below VSYS to fully turn on BATFET. BATFET is in linear mode to regulate VSYS at minimum system voltage when battery is depleted. BATFET is fully on during fast charge and supplement mode. |
| BTST1 | 30 | PWR | Buck mode high side power MOSFET driver power supply. Connect a 0.047- μF capacitor between SW1 and BTST1. The bootstrap diode between REGN and BTST1 is integrated. |
| BTST2 | 25 | PWR | Boost mode high side power MOSFET driver power supply. Connect a 0.047- μF capacitor between SW2 and BTST2. The bootstrap diode between REGN and BTST2 is integrated. |
| CELL_BATPRESZ | 18 | I | Battery cell selection pin for 1–4 cell battery setting. CELL_BATPRESZ pin is biased from VDDA. CELL_BATPRESZ pin also sets SYSOVP threshold to 5 V for 1-cell, 12 V for 2-cell, and 19.5 V for 3-cell/4-cell. CELL_BATPRESZ pin is pulled below $V_{\text{CELL_BATPRESZ_FALL}}$ to indicate battery removal. The device exits LEARN mode, and disables charge. REG0x05/04() goes back to default. |

Pin Functions (continued)

| PIN | | I/O | DESCRIPTION |
|----------|--------|-----|---|
| NAME | NUMBER | | |
| CHRG_OK | 4 | O | Open drain active high indicator to inform the system good power source is connected to the charger input. Connect to the pullup rail via 10-kΩ resistor. When VBUS rises above 3.5V or falls below 24.5V, CHRG_OK is HIGH after 50ms deglitch time. When VBUS is falls below 3.2 V or rises above 26 V, CHRG_OK is LOW. When fault occurs, CHRG_OK is asserted LOW. |
| CMPIN | 14 | I | Input of independent comparator. The independent comparator compares the voltage sensed on CMPIN pin to internal reference, and its output is on CMPOUT pin. Internal reference, output polarity and deglitch time is selectable by I2C. With polarity HIGH (REG0x30[6] = 1), place a resistor between CMPIN and CMPOUT to program hysteresis. With polarity LOW (REG0x30[6] = 0), the internal hysteresis is 100 mV. If the independent comparator is not in use, tie CMPIN to ground. |
| CMPOUT | 15 | O | Open-drain output of independent comparator. Place pullup resistor from CMPOUT to pullup supply rail. Internal reference, output polarity and deglitch time are selectable by I2C. |
| COMP2 | 17 | I | Buck boost converter compensation pin 2. Refer to bq25700 EVM schematic for COMP2 pin RC network. |
| COMP1 | 16 | I | Buck boost converter compensation pin 1. Refer to bq25700 EVM schematic for COMP1 pin RC network. |
| EN_OTG | 5 | I | Active HIGH to enable OTG mode. When EN_OTG pin is HIGH and REG0x35[4] is HIGH, OTG can be enabled, refer to USB On-The-Go (OTG) for details of how to enable OTG function |
| HIDRV1 | 31 | O | Buck mode high side power MOSFET (Q1) driver. Connect to high side n-channel MOSFET gate. |
| HIDRV2 | 24 | O | Boost mode high side power MOSFET(Q4) driver. Connect to high side n-channel MOSFET gate. |
| IADPT | 8 | I/O | Buffered adapter current output. $V_{(IADPT)} = 20 \text{ or } 40 \times (V_{(ACP)} - V_{(ACN)})$. With ratio selectable in REG0x00[4]. Place a resistor from the IADPT pin to ground corresponding to inductor in use. For 2.2 μH, the resistor is 137 kΩ. Place 100-pF or less ceramic decoupling capacitor from IADPT pin to ground. IADPT output voltage is clamped below 3.3 V. |
| IBAT | 9 | O | Buffered battery current selected by I2C. $V_{(IBAT)} = 8 \text{ or } 16 \times (V_{(SRP)} - V_{(SRN)})$ for charge current, or $V_{(IBAT)} = 8 \text{ or } 16 \times (V_{(SRN)} - V_{(SRP)})$ for discharge current, with ratio selectable in REG0x00[3]. Place 100-pF or less ceramic decoupling capacitor from IBAT pin to ground. This pin can be floating if not in use. Its output voltage is clamped below 3.3 V. |
| ILIM_HIZ | 6 | I | Input current limit input. Program ILIM_HIZ voltage by connecting a resistor divider from supply rail to ILIM_HIZ pin to ground. The pin voltage is calculated as: $V_{(ILIM_HIZ)} = 1 \text{ V} + 40 \times \text{IDPM} \times \text{RAC}$, in which IDPM is the target input current. The input current limit used by the charger is the lower setting of ILIM_HIZ pin and REG0x0F() and REG0x0E(). When the pin voltage is below 0.4 V, the device enters Hi-Z mode with low quiescent current. When the pin voltage is above 0.8 V, the device is out of Hi-Z mode. |
| LODRV1 | 29 | O | Buck mode low side power MOSFET (Q2) driver. Connect to low side n-channel MOSFET gate. |
| LODRV2 | 26 | O | Boost mode low side power MOSFET (Q3) driver. Connect to low side n-channel MOSFET gate. |
| PGND | 27 | GND | Device power ground. |
| PROCHOT | 11 | O | Active low open drain output of processor hot indicator. It monitors adapter input current, battery discharge current, and system voltage. After any event in the PROCHOT profile is triggered, a pulse is asserted. The minimum pulse width is adjustable in REG0x36[5:2]. |
| PSYS | 10 | O | Current mode system power monitor. The output current is proportional to the total power from the adapter and battery. The gain is selectable through I2C. Place a resistor from PSYS to ground to generate output voltage. This pin can be floating if not in use. Its output voltage is clamped below 3.3 V. Place a capacitor in parallel with the resistor for filtering. |
| REGN | 28 | PWR | 6-V linear regulator output supplied from VBUS or VSYS. The LDO is active when VBUS above V_{VBUS_CONVEN} . Connect a 2.2- or 3.3-μF ceramic capacitor from REGN to power ground. REGN pin output is for power stage gate drive. |
| SCL | 13 | I | I2C clock input. Connect to clock line from the host controller or smart battery. Connect a 10-kΩ pullup resistor according to I2C specifications. |
| SDA | 12 | I/O | I2C open-drain data I/O. Connect to data line from the host controller or smart battery. Connect a 10-kΩ pullup resistor according to I2C specifications. |

Pin Functions (continued)

| PIN | | I/O | DESCRIPTION |
|-------------|--------|-----|--|
| NAME | NUMBER | | |
| SRN | 19 | PWR | Charge current sense resistor negative input. SRN pin is for battery voltage sensing as well. Connect SRN pin with optional 0.1- μ F ceramic capacitor to GND for common-mode filtering. Connect a 0.1- μ F ceramic capacitor from SRP to SRN to provide differential mode filtering. The leakage current on SRP and SRN are matched. For reverse battery plug-in protection, 10- Ω series resistors are placed on SRP and SRN. |
| SRP | 20 | PWR | Charge current sense resistor positive input. Connect 0.1- μ F ceramic capacitor from SRP to SRN to provide differential mode filtering. The leakage current on SRP and SRN are matched. For reverse battery plug-in protection, 10- Ω series resistors are placed on SRP and SRN. Connect SRP pin with optional 0.1- μ F ceramic capacitor to GND for common-mode filtering. |
| SW1 | 32 | PWR | Buck mode high side power MOSFET driver source. Connect to the source of the high side n-channel MOSFET. |
| SW2 | 23 | PWR | Boost mode high side power MOSFET driver source. Connect to the source of the high side n-channel MOSFET. |
| VBUS | 1 | PWR | Charger input voltage. An input low pass filter of 1 Ω and 0.47 μ F (minimum) is recommended. |
| VDDA | 7 | PWR | Internal reference bias pin. Connect a 10- Ω resistor from REGN to VDDA and a 1- μ F ceramic capacitor from VDDA to power ground. |
| VSYS | 22 | PWR | Charger system voltage sensing. The system voltage regulation limit is programmed in REG0x05/04() and REG0X0D/0C(). |
| Thermal pad | – | – | Exposed pad beneath the IC. Analog ground and power ground star-connected near the IC's ground. Always solder thermal pad to the board, and have vias on the thermal pad plane connecting to power ground planes. It also serves as a thermal pad to dissipate the heat. |

7 Specifications

7.1 Absolute Maximum Ratings

over operating free-air temperature range (unless otherwise noted)⁽¹⁾⁽²⁾

| | | MIN | MAX | UNIT |
|--|---|------|-----|------|
| Voltage | SRN, SRP, ACN, ACP, VBUS, VSYS, $\overline{\text{BATDRV}}$ | -0.3 | 30 | V |
| | SW1, SW2 | -2.0 | 30 | |
| | BTST1, BTST2, HIDRV1, HIDRV2 | -0.3 | 36 | |
| | LODRV1, LODRV2 (2% duty cycle) | -4.0 | 7 | |
| | HIDRV1, HIDRV2 (2% duty cycle) | -4.0 | 36 | |
| | SW1, SW2 (2% duty cycle) | -4.0 | 30 | |
| | SDA, SCL, REGN, CHRГ_OK, CELL_BATPRESZ, ILIM_HIZ, LODRV1, LODRV2, VDDA, COMP1, COMP2, CMPIN, CMPOUT, EN_OTG | -0.3 | 7 | |
| | $\overline{\text{PROCHOT}}$ | -0.3 | 5.5 | |
| | IADPT, IBAT, PSYS | -0.3 | 3.6 | |
| Differential voltage | BTST1-SW1, BTST2-SW2, HIDRV1-SW1, HIDRV2-SW2 | -0.3 | 7 | V |
| | SRP-SRN, ACP-ACN | -0.5 | 0.5 | |
| Junction temperature range, T _J | | -40 | 155 | °C |
| Storage temperature, T _{stg} | | -40 | 155 | °C |

- Stresses beyond those listed under *Absolute Maximum Ratings* may cause permanent damage to the device. These are stress ratings only, which do not imply functional operation of the device at these or any other conditions beyond those indicated under *Recommended Operating Conditions*. Exposure to absolute-maximum-rated conditions for extended periods may affect device reliability.
- All voltages are with respect to GND if not specified. Currents are positive into, negative out of the specified terminal. Consult Packaging Section of the data book for thermal limitations and considerations of packages.

7.2 ESD Ratings

| | | VALUE | UNIT |
|--|--|-------|------|
| V _(ESD) Electrostatic discharge | Human-body model (HBM), per ANSI/ESDA/JEDEC JS-001 ⁽¹⁾ | ±2000 | V |
| | Charged-device model (CDM), per JEDEC specification JESD22-C101 ⁽²⁾ | ±500 | |

- JEDEC document JEP155 states that 500-V HBM allows safe manufacturing with a standard ESD control process.
- JEDEC document JEP157 states that 250-V CDM allows safe manufacturing with a standard ESD control process.

7.3 Recommended Operating Conditions

over operating free-air temperature range (unless otherwise noted)

| | | MIN | MAX | UNIT |
|--|---|-------|------|------|
| Voltage | ACN, ACP, VBUS | 0 | 24 | V |
| | SRN, SRP, VSYS, $\overline{\text{BATDRV}}$ | 0 | 19.2 | |
| | SW1, SW2 | -2 | 24 | |
| | BTST1, BTST2, HIDRV1, HIDRV2 | 0 | 30 | |
| | SDA, SCL, REGN, CHRГ_OK, CELL_BATPRESZ, ILIM_HIZ, LODRV1, LODRV2, VDDA, COMP1, COMP2, CMPIN, CMPOUT | 0 | 6.5 | |
| | $\overline{\text{PROCHOT}}$ | 0 | 5.3 | |
| | IADPT, IBAT, PSYS | 0 | 3.3 | |
| Differential voltage | BTST1-SW1, BTST2-SW2, HIDRV1-SW1, HIDRV2-SW2 | 0 | 6.5 | V |
| | SRP-SRN, ACP-ACN | -0.35 | 0.35 | |
| Junction temperature, T _J | | -40 | 125 | °C |
| Operating free-air temperature, T _A | | -40 | 85 | °C |

7.4 Thermal Information

| THERMAL METRIC ⁽¹⁾ | | bq25703A | |
|-------------------------------|--|------------|------|
| | | RSN (WQFN) | |
| | | 32 PINS | |
| Symbol | Description | Value | UNIT |
| $R_{\theta JA}$ | Junction-to-ambient thermal resistance | 37.2 | °C/W |
| $R_{\theta JC(top)}$ | Junction-to-case (top) thermal resistance | 26.1 | °C/W |
| $R_{\theta JB}$ | Junction-to-board thermal resistance | 7.8 | °C/W |
| Ψ_{JT} | Junction-to-top characterization parameter | 0.3 | °C/W |
| Ψ_{JB} | Junction-to-board characterization parameter | 7.8 | °C/W |
| $R_{\theta JC(bot)}$ | Junction-to-case (bottom) thermal resistance | 2.3 | °C/W |

(1) For more information about traditional and new thermal metrics, see the [Semiconductor and IC Package Thermal Metrics](#) application report.

7.5 Electrical Characteristics

over $T_J = -40$ to 125°C (unless otherwise noted)

| PARAMETER | TEST CONDITIONS | MIN | TYP | MAX | UNIT |
|--|---|-----------------------------------|--------------------|------|------|
| V_{INPUT_OP} | Input voltage operating range | 3.5 | | 26 | V |
| REGULATION ACCURACY | | | | | |
| MAX SYSTEM VOLTAGE REGULATION | | | | | |
| V_{SYSMAX_RNG} | System voltage regulation, measured on V_{SYS} | 1.024 | | 19.2 | V |
| V_{SYSMAX_ACC} | System voltage regulation accuracy (charge disable) | REG0x05/04() = 0x41A0H (16.800 V) | $V_{SRN} + 160$ mV | | V |
| | | | -2% | 2% | |
| | | REG0x05/04() = 0x3130H (12.592 V) | $V_{SRN} + 160$ mV | | V |
| | | | -2% | 2% | |
| | REG0x05/04() = 0x20D0H (8.400 V) | $V_{SRN} + 160$ mV | | V | |
| | | -3% | 3% | | |
| | REG0x05/04() = 0x1060H (4.192 V) | $V_{SRN} + 160$ mV | | V | |
| | | -3% | 3% | | |
| MINIMUM SYSTEM VOLTAGE REGULATION | | | | | |
| V_{SYSMIN_RNG} | System voltage regulation, measured on V_{SYS} | 1.024 | | 19.2 | V |
| $V_{SYSMIN_REG_ACC}$ | Minimum system voltage regulation accuracy (charge enable, VBAT below REG0x0D/0C() setting) | REG0x0D/0C() = 0x3000H | 12.288 | | V |
| | | | -2% | 2% | |
| | | REG0x0D/0C() = 0x2400H | 9.216 | | V |
| | | | -2% | 2% | |
| | REG0x0D/0C() = 0x1800H | 6.144 | | V | |
| | | -3% | 3% | | |
| | REG0x0D/0C() = 0x0E00H | 3.584 | | V | |
| | | -3% | 4% | | |
| CHARGE VOLTAGE REGULATION | | | | | |
| V_{BAT_RNG} | Battery voltage regulation | 1.024 | | 19.2 | V |
| $V_{BAT_REG_ACC}$ | Battery voltage regulation accuracy (charge enable) (0°C to 85°C) | REG0x05/04() = 0x41A0H | 16.8 | | V |
| | | | -0.5% | 0.5% | |
| | | REG0x05/04() = 0x3130H | 12.592 | | V |
| | | | -0.5% | 0.5% | |
| | REG0x05/04() = 0x20D0H | 8.4 | | V | |
| | | -0.6% | 0.6% | | |
| | REG0x05/04() = 0x1060H | 4.192 | | V | |
| | | -1.1% | 1.2% | | |

Electrical Characteristics (continued)

over $T_J = -40$ to 125°C (unless otherwise noted)

| PARAMETER | | TEST CONDITIONS | MIN | TYP | MAX | UNIT | |
|---|---|--|------|------|-------|---------------|----|
| CHARGE CURRENT REGULATION IN FAST CHARGE | | | | | | | |
| $V_{\text{IREG_CHG_RNG}}$ | Charge current regulation differential voltage range | $V_{\text{IREG_CHG}} = V_{\text{SRP}} - V_{\text{SRN}}$ | 0 | | 81.28 | mV | |
| $I_{\text{CHRG_REG_ACC}}$ | Charge current regulation accuracy 10-m Ω current sensing resistor, VBAT above 0x0D/0C() setting (0°C to 85°C) | REG0x03/02() = 0x1000H | | 4096 | | mA | |
| | | | -3% | | 2% | | |
| | | REG0x03/02() = 0x0800H | | 2048 | | 3% | mA |
| | | | -4% | | | | |
| | | REG0x03/02() = 0x0400H | | 1024 | | 6% | mA |
| | | | -5% | | | | |
| | | REG0x03/02() = 0x0200H | | 512 | | mA | |
| | | | -12% | | 12% | | |
| CHARGE CURRENT REGULATION IN LDO MODE | | | | | | | |
| I_{CLAMP} | Pre-charge current clamp | CELL 2s-4s | | 384 | | mA | |
| | | CELL 1 s, $V_{\text{SRN}} < 3$ V | | 384 | | mA | |
| | | CELL 1 s, 3 V $< V_{\text{SRN}} < V_{\text{SYSMIN}}$ | | 2 | | A | |
| $I_{\text{PRECHRG_REG_ACC}}$ | Pre-charge current regulation accuracy with 10- Ω SRP/SRN series resistor, VBAT below REG0x0D/0C() setting (0°C to 85°C) | REG0x03/02() = 0x0180H | | 384 | | mA | |
| | | 2S-4S | -15% | | 15% | | |
| | | 1S | -25% | | 25% | | |
| | | REG0x03/02() = 0x0100H | | 256 | | mA | |
| | | 2S-4S | -20% | | 20% | | |
| | | 1S | -35% | | 35% | | |
| | | REG0x03/02() = 0x00C0H | | 192 | | mA | |
| | | 2S-4S | -25% | | 25% | | |
| | | 1S | -50% | | 50% | | |
| | | REG0x03/02() = 0x0080H | | 128 | | mA | |
| | | 2S-4S | -30% | | 30% | | |
| $I_{\text{LEAK_SRP_SRN}}$ | SRP, SRN leakage current mismatch (0°C to 85°C) | | -12 | | 10 | μA | |
| INPUT CURRENT REGULATION | | | | | | | |
| $V_{\text{IREG_DPM_RNG}}$ | Input current regulation differential voltage range | $V_{\text{IREG_DPM}} = V_{\text{ACP}} - V_{\text{ACN}}$ | 0.5 | | 64 | mV | |
| $I_{\text{DPM_REG_ACC}}$ | Input current regulation accuracy (-40°C to 105°C) with 10-m Ω ACP/ACN series resistor | REG0x0F/0E() = 0x4FFFH | 3820 | | 4000 | mA | |
| | | REG0x0F/0E() = 0x3BFFH | 2830 | | 3000 | mA | |
| | | REG0x0F/0E() = 0x1DFFH | 1350 | | 1500 | mA | |
| | | REG0x0F/0E() = 0x09FFH | 340 | | 500 | mA | |
| $I_{\text{LEAK_ACP_ACN}}$ | ACP, ACN leakage current mismatch | | -16 | | 10 | μA | |
| $V_{\text{IREG_DPM_RNG_ILIM}}$ | Voltage Range for input current regulation | | 1 | | 4 | V | |
| $I_{\text{DPM_REG_ACC_ILIM}}$ | Input Current Regulation Accuracy on ILIM_HIZ pin $V_{\text{ILIM_HIZ}} = 1$ V + $40 \times I_{\text{DPM}} \times R_{\text{AC}}$ with 10-m Ω ACP/ACN series resistor | $V_{\text{ILIM_HIZ}} = 2.6$ V | 3800 | 4000 | 4200 | mA | |
| | | $V_{\text{ILIM_HIZ}} = 2.2$ V | 2800 | 3000 | 3200 | mA | |
| | | $V_{\text{ILIM_HIZ}} = 1.6$ V | 1300 | 1500 | 1700 | mA | |
| | | $V_{\text{ILIM_HIZ}} = 1.2$ V | 300 | 500 | 700 | mA | |
| $I_{\text{LEAK_ILIM}}$ | $I_{\text{LIM_HIZ}}$ pin leakage | | -1 | | 1 | μA | |
| INPUT VOLTAGE REGULATION | | | | | | | |
| $V_{\text{IREG_DPM_RNG}}$ | Input voltage regulation range | Voltage on VBUS | 3.2 | | 19.52 | V | |

Electrical Characteristics (continued)

 over $T_J = -40$ to 125°C (unless otherwise noted)

| PARAMETER | TEST CONDITIONS | MIN | TYP | MAX | UNIT | |
|----------------------------------|--|--|-------|--------|------|---------------|
| $V_{\text{DPM_REG_ACC}}$ | Input voltage regulation accuracy | REG0x0B/0A()=0x3C80H | | 18688 | mV | |
| | | | -2% | 2% | | |
| | | REG0x0B/0A()=0x1E00H | | 10880 | mV | |
| | | | -2.5% | 2.5% | | |
| | | REG0x0B/0A()=0x0500H | | 4480 | mV | |
| | | -3% | 5% | | | |
| OTG CURRENT REGULATION | | | | | | |
| $V_{\text{IOTG_REG_RNG}}$ | Input current regulation differential voltage range | $V_{\text{IREG_DPM}} = V_{\text{ACP}} - V_{\text{ACN}}$ | 0 | 81.28 | mV | |
| $I_{\text{OTG_ACC}}$ | Input current regulation accuracy with 50-mA LSB, with 10- Ω ACP/ACN series resistor | REG0x09/08() = 0x3C00H | 2800 | 3000 | 3200 | mA |
| | | REG0x09/08() = 0x1E00H | 1300 | 1500 | 1700 | mA |
| | | REG0x09/08() = 0x0A00H | 300 | 500 | 700 | mA |
| OTG VOLTAGE REGULATION | | | | | | |
| $V_{\text{IREG_DPM_RNG}}$ | Input voltage regulation range | Voltage on VBUS | 4.48 | 20.8 | V | |
| $V_{\text{OTG_REG_ACC}}$ | OTG voltage regulation accuracy | REG0x07/06()=0x3CC0H | | 20.032 | V | |
| | | | -2% | 2% | | |
| | | REG0x07/06()=0x1D80H | | 12.032 | V | |
| | | | -2% | 2% | | |
| | | REG0x07/06()=0x0240H | | 5.056 | V | |
| | | -3% | 3% | | | |
| REFERENCE AND BUFFER | | | | | | |
| REGN REGULATOR | | | | | | |
| $V_{\text{REGN_REG}}$ | REGN regulator voltage (0 mA–60 mA) | $V_{\text{VBUS}} = 10\text{ V}$ | 5.7 | 6 | 6.3 | V |
| V_{DROPOUT} | REGN voltage in drop out mode | $V_{\text{VBUS}} = 5\text{ V}$, $I_{\text{LOAD}} = 20\text{ mA}$ | 3.8 | 4.3 | 4.6 | V |
| $I_{\text{REGN_LIM_Charging}}$ | REGN current limit when converter is enabled | $V_{\text{VBUS}} = 10\text{ V}$, force $V_{\text{REGN}} = 4\text{ V}$ | 50 | 65 | | mA |
| C_{REGN} | REGN output capacitor required for stability | $I_{\text{LOAD}} = 100\text{ }\mu\text{A}$ to 50 mA | 2.2 | | | μF |
| C_{VDDA} | REGN output capacitor required for stability | $I_{\text{LOAD}} = 100\text{ }\mu\text{A}$ to 50 mA | 1 | | | μF |
| QUIESCENT CURRENT | | | | | | |
| $I_{\text{BAT_BATFET_ON}}$ | System powered by battery. BATFET on. $I_{\text{SRN}} + I_{\text{SRP}} + I_{\text{SW2}} + I_{\text{BTST2}} + I_{\text{SW1}} + I_{\text{BTST1}} + I_{\text{ACP}} + I_{\text{ACN}} + I_{\text{VBUS}} + I_{\text{VSY}} + I_{\text{VDDA}}$ | $V_{\text{BAT}} = 18\text{ V}$, REG0x01[7] = 1, in low power mode | | 22 | 45 | μA |
| | | $V_{\text{BAT}} = 18\text{ V}$, REG0x01[7] = 1, REG0x31[6:5] = 01, REGN off | | 105 | 175 | μA |
| | | $V_{\text{BAT}} = 18\text{ V}$, REG0x01[7] = 1, REG0x31[6:5] = 10, REGN off | | 60 | 90 | μA |
| | | $V_{\text{BAT}} = 18\text{ V}$, REG0x01[7] = 0, REG0x31[4] = 0, REGN on, EN_PSYS | | 860 | 1150 | μA |
| | | $V_{\text{BAT}} = 18\text{ V}$, REG0x01[7] = 0, REG0x31[4] = 1, REGN on | | 960 | 1250 | |
| $I_{\text{AC_SW_LIGHT_buck}}$ | Input current during PFM in buck mode, no load, $I_{\text{VBUS}} + I_{\text{ACP}} + I_{\text{ACN}} + I_{\text{VSY}} + I_{\text{SRP}} + I_{\text{SRN}} + I_{\text{SW1}} + I_{\text{BTST}} + I_{\text{SW2}} + I_{\text{BTST2}}$ | $V_{\text{IN}} = 20\text{ V}$, $V_{\text{BAT}} = 12.6\text{ V}$, 3 s, REG0x01[2] = 0; MOSFET Qg = 4 nC | | 2.2 | | mA |

Electrical Characteristics (continued)

over $T_J = -40$ to 125°C (unless otherwise noted)

| PARAMETER | TEST CONDITIONS | MIN | TYP | MAX | UNIT | | |
|-------------------------------------|--|--|------|------|------|-----------------|---|
| $I_{AC_SW_LIGHT_boost}$ | Input current during PFM in boost mode, no load, $I_{VBUS} + I_{ACP} + I_{ACN} + I_{VSY} + I_{SRP} + I_{SRN} + I_{SW1} + I_{BTST2} + I_{SW2} + I_{BTST2}$ | $V_{IN} = 5\text{ V}$, $V_{BAT} = 8.4\text{ V}$, 2 s, $REG0x01[2] = 0$; MOSFET $Q_g = 4\text{ nC}$ | 2.7 | | mA | | |
| $I_{AC_SW_LIGHT_buckboost}$ | Input current during PFM in buck boost mode, no load, $I_{VBUS} + I_{ACP} + I_{ACN} + I_{VSY} + I_{SRP} + I_{SRN} + I_{SW1} + I_{BTST1} + I_{SW2} + I_{BTST2}$ | $V_{IN} = 12\text{ V}$, $V_{BAT} = 12\text{ V}$, $REG0x01[2] = 0$; MOSFET $Q_g = 4\text{ nC}$ | 2.4 | | mA | | |
| $I_{OTG_STANDBY}$ | Quiescent current during PFM in OTG mode $I_{VBUS} + I_{ACP} + I_{ACN} + I_{VSY} + I_{SRP} + I_{SRN} + I_{SW1} + I_{BTST2} + I_{SW2} + I_{BTST2}$ | $V_{BAT} = 8.4\text{ V}$, $V_{BUS} = 5\text{ V}$, 800-kHz switching frequency, MOSFET $Q_g = 4\text{ nC}$ | 3 | | mA | | |
| | | $V_{BAT} = 8.4\text{ V}$, $V_{BUS} = 12\text{ V}$, 800-kHz switching frequency, MOSFET $Q_g = 4\text{ nC}$ | 4.2 | | | | |
| | | $V_{BAT} = 8.4\text{ V}$, $V_{BUS} = 20\text{ V}$, 800-kHz switching frequency, MOSFET $Q_g = 4\text{ nC}$ | 6.2 | | | | |
| V_{ACP/N_OP} | Input common mode range | Voltage on ACP/ACN | | 3.8 | 26 | V | |
| V_{IADPT_CLAMP} | I_{ADPT} output clamp voltage | | | 3.1 | 3.2 | 3.3 | V |
| I_{IADPT} | I_{ADPT} output current | | | | 1 | mA | |
| A_{IADPT} | Input current sensing gain | $V_{(IADPT)} / V_{(ACP-ACN)}$, $REG0x00[4] = 0$ | 20 | | V/V | | |
| | | $V_{(IADPT)} / V_{(ACP-ACN)}$, $REG0x00[4] = 1$ | 40 | | V/V | | |
| V_{IADPT_ACC} | Input current monitor accuracy | $V_{(ACP-ACN)} = 40.96\text{ mV}$ | -2% | | 2% | | |
| | | $V_{(ACP-ACN)} = 20.48\text{ mV}$ | -3% | | 3% | | |
| | | $V_{(ACP-ACN)} = 10.24\text{ mV}$ | -6% | | 6% | | |
| | | $V_{(ACP-ACN)} = 5.12\text{ mV}$ | -10% | | 10% | | |
| C_{IADPT_MAX} | Maximum output load capacitance | | | | 100 | pF | |
| V_{SRP/N_OP} | Battery common mode range | Voltage on SRP/SRN | | 2.5 | 18 | V | |
| V_{IBAT_CLAMP} | IBAT output clamp voltage | | | 3.05 | 3.2 | 3.3 | V |
| I_{IBAT} | IBAT output current | | | | 1 | mA | |
| A_{IBAT} | Charge and discharge current sensing gain on IBAT pin | $V_{(IBAT)} / V_{(SRN-SRP)}$, $REG0x00[3] = 0$, | | 8 | V/V | | |
| | | $V_{(IBAT)} / V_{(SRN-SRP)}$, $REG0x00[3] = 1$, | | 16 | V/V | | |
| $I_{IBAT_CHG_ACC}$ | Charge and discharge current monitor accuracy on IBAT pin | $V_{(SRN-SRP)} = 40.96\text{ mV}$ | -2% | | 2% | | |
| | | $V_{(SRN-SRP)} = 20.48\text{ mV}$ | -3% | | 4% | | |
| | | $V_{(SRN-SRP)} = 10.24\text{ mV}$ | -6% | | 6% | | |
| | | $V_{(SRN-SRP)} = 5.12\text{ mV}$ | -12% | | 12% | | |
| C_{IBAT_MAX} | Maximum output load capacitance | | | | 100 | pF | |
| SYSTEM POWER SENSE AMPLIFIER | | | | | | | |
| V_{PSYS} | PSYS output voltage range | | | 0 | 3.3 | V | |
| I_{PSYS} | PSYS output current | | | 0 | 160 | μA | |
| A_{PSYS} | PSYS system gain | $V_{(PSYS)} / (P_{(IN)} + P_{(BAT)})$, $REG0x31[1] = 1$ | | 1 | | $\mu\text{A/W}$ | |

Electrical Characteristics (continued)

 over $T_J = -40$ to 125°C (unless otherwise noted)

| PARAMETER | | TEST CONDITIONS | MIN | TYP | MAX | UNIT |
|---|--|---|------|-------|------|------|
| V _{PSYS_ACC} | PSYS gain accuracy (REG0x31[1] = 1) | Adapter only with system power = 19.5 V / 45 W, T _A = 0 to 85°C | -5% | | 5% | |
| | | Adapter only with system power = 19.5 V / 45 W, T _A = -40 to 125°C | -7% | | 6% | |
| | | Battery only with system power = 11 V / 44 W, T _A = 0 to 85°C | -5% | | 5% | |
| | | Battery only with system power = 11 V / 44 W, T _A = -40 to 125°C | -6% | | 6% | |
| V _{PSYS_CLAMP} | PSYS clamp voltage | | 3 | | 3.3 | V |
| COMPARATOR | | | | | | |
| VBUS UNDER VOLTAGE LOCKOUT COMPARATOR | | | | | | |
| V _{VBUS_UVLOZ} | VBUS undervoltage rising threshold | VBUS rising | 2.34 | 2.55 | 2.77 | V |
| V _{VBUS_UVLO} | VBUS undervoltage falling threshold | VBUS falling | 2.2 | 2.4 | 2.6 | V |
| V _{VBUS_UVLO_HYST} | VBUS undervoltage hysteresis | | | 150 | | mV |
| V _{VBUS_CONVEN} | VBUS converter enable rising threshold | VBUS rising | 3.2 | 3.5 | 3.9 | V |
| V _{VBUS_CONVENZ} | VBUS converter enable falling threshold | VBUS falling | 2.9 | 3.2 | 3.5 | V |
| V _{VBUS_CONVEN_HYST} | VBUS converter enable hysteresis | | | 400 | | mV |
| BATTERY UNDER VOLTAGE LOCKOUT COMPARATOR | | | | | | |
| V _{VBAT_UVLOZ} | VBAT undervoltage rising threshold | VSRN rising | 2.35 | 2.55 | 2.75 | V |
| V _{VBAT_UVLO} | VBAT undervoltage falling threshold | VSRN falling | 2.2 | 2.4 | 2.6 | V |
| V _{VBAT_UVLO_HYST} | VBAT undervoltage hysteresis | | | 150 | | mV |
| V _{VBAT_OTGEN} | VBAT OTG enable rising threshold | VSRN rising | 3.3 | 3.55 | 3.75 | V |
| V _{VBAT_OTGENZ} | VBAT OTG enable falling threshold | VSRN falling | 3 | 3.2 | 3.4 | V |
| V _{VBAT_OTGEN_HYST} | VBAT OTG enable hysteresis | | | 350 | | mV |
| VBUS UNDER VOLTAGE COMPARATOR (OTG MODE) | | | | | | |
| V _{VBUS_OTG_UV} | VBUS undervoltage falling threshold | As percentage of REG0x07/06() | | 85.0% | | |
| t _{VBUS_OTG_UV} | VBUS undervoltage deglitch time | | | 7 | | ms |
| VBUS OVER VOLTAGE COMPARATOR (OTG MODE) | | | | | | |
| V _{VBUS_OTG_OV} | VBUS overvoltage rising threshold | As percentage of REG0x07/06() | | 105% | | |
| t _{VBUS_OTG_OV} | VBUS Over-Voltage Deglitch Time | | | 10 | | ms |
| V _{BAT_SYSMIN_RISE} | LDO mode to fast charge mode threshold, VSRN rising | as percentage of 0x0D/0C() | 98% | 100% | 102% | |
| V _{BAT_SYSMIN_FALL} | LDO mode to fast charge mode threshold, VSRN falling | as percentage of 0x0D/0C() | | 97.5% | | |

Electrical Characteristics (continued)

over $T_J = -40$ to 125°C (unless otherwise noted)

| PARAMETER | | TEST CONDITIONS | MIN | TYP | MAX | UNIT |
|--|--|--|--------|------|------|---------------|
| $V_{\text{BAT_SYSMIN_HYST}}$ | Fast charge mode to LDO mode threshold hysteresis | as percentage of 0x0D/0C() | | 2.5% | | |
| BATTERY LOWV COMPARATOR (Pre-charge to Fast Charge Threshld for 1S) | | | | | | |
| $V_{\text{BATLV_FALL}}$ | BATLOWV falling threshold | 1 s | | 2.80 | | V |
| $V_{\text{BATLV_RISE}}$ | BATLOWV rising threshold | | | 3.00 | | V |
| $V_{\text{BATLV_RHYST}}$ | BATLOWV hysteresis | | | 200 | | mV |
| INPUT OVER-VOLTAGE COMPARATOR (ACOV) | | | | | | |
| $V_{\text{ACOV_RISE}}$ | VBUS overvoltage rising threshold | VBUS rising | 25 | 26 | 27 | V |
| $V_{\text{ACOV_FALL}}$ | VBUS overvoltage falling threshold | VBUS falling | 24 | 24.5 | 25 | V |
| $V_{\text{ACOV_HYST}}$ | VBUS overvoltage hysteresis | | | 1.5 | | V |
| $t_{\text{ACOV_RISE_DEG}}$ | VBUS overvoltage rising deglitch | VBUS rising to stop converter | | 100 | | μs |
| $t_{\text{ACOV_FALL_DEG}}$ | VBUS overvoltage falling deglitch | VBUS falling to start converter | | 1 | | ms |
| INPUT OVER CURRENT COMPARATOR (ACOC) | | | | | | |
| V_{ACOC} | ACP to ACN rising threshold, w.r.t. ILIM2 in REG0x37[7:3] | Voltage across input sense resistor rising, Reg0x32[2] = 1 | 195% | 210% | 225% | |
| $V_{\text{ACOC_FLOOR}}$ | Measure between ACP and ACN | Set IDPM to minimum | 44 | 50 | 56 | mV |
| $V_{\text{ACOC_CEILING}}$ | Measure between ACP and ACN | Set IDPM to maximum | 172 | 180 | 188 | mV |
| $t_{\text{ACOC_DEG_RISE}}$ | Rising deglitch time | Deglitch time to trigger ACOC | | 250 | | μs |
| $t_{\text{ACOC_RELAX}}$ | Relax time | Relax time before converter starts again | | 250 | | ms |
| SYSTEM OVER-VOLTAGE COMPARATOR (SYSOVP) | | | | | | |
| $V_{\text{SYSOVP_RISE}}$ | System overvoltage rising threshold to turn off converter | 1 s | 4.85 | 5 | 5.1 | V |
| | | 2 s | 11.7 | 12 | 12.2 | |
| | | 3 s | 19 | 19.5 | 20 | |
| | | 4 s | 19 | 19.5 | 20 | |
| $V_{\text{SYSOVP_FALL}}$ | System overvoltage falling threshold | 1 s | | 4.8 | | V |
| | | 2 s | | 11.5 | | |
| | | 3 s | | 19 | | |
| | | 4 s | | 19 | | |
| I_{SYSOVP} | Discharge current when SYSOVP stop switching was triggered | on SYS | | 20 | | mA |
| BAT OVER-VOLTAGE COMPARATOR (BATOVP) | | | | | | |
| $V_{\text{BATOVP_RISE}}$ | Overvoltage rising threshold as percentage of $V_{\text{BAT_REG}}$ in REG0x05/04() | 1 s, 4.2 V | 102.5% | 104% | 106% | |
| | | 2 s - 4 s | 102.5% | 104% | 105% | |
| $V_{\text{BATOVP_FALL}}$ | Overvoltage falling threshold as percentage of $V_{\text{BAT_REG}}$ in REG0x05/04() | 1 s | 100% | 102% | 104% | |
| | | 2 s - 4 s | 100% | 102% | 103% | |
| $V_{\text{BATOVP_HYST}}$ | Overvoltage hysteresis as percentage of $V_{\text{BAT_REG}}$ in REG0x05/04() | 1 s | | 2% | | |
| | | 2 s - 4 s | | 2% | | |
| I_{BATOVP} | Discharge current during BATOVP | on VSYS pin | | 20 | | mA |

Electrical Characteristics (continued)

 over $T_J = -40$ to 125°C (unless otherwise noted)

| PARAMETER | | TEST CONDITIONS | MIN | TYP | MAX | UNIT |
|--|---|-------------------------------|------|------|------|------------------|
| $t_{\text{BATOVP_RISE}}$ | Overvoltage rising deglitch to turn off BATDRV to disable charge | | | 20 | | ms |
| CONVERTER OVER-CURRENT COMPARATOR (Q2) | | | | | | |
| VOCP_limit_Q2 | Converter Over-Current Limit | Reg0x32[5]=1 | | 150 | | mV |
| | | Reg0x32[5]=0 | | 210 | | |
| VOCP_limit_SYSSH ORT_Q2 | System Short or SRN<2.5 V | Reg0x32[5]=1 | | 45 | | mV |
| | | Reg0x32[5]=0 | | 60 | | |
| CONVERTER OVER-CURRENT COMPARATOR (ACX) | | | | | | |
| VOCP_limit_ACX | Converter Over-Current Limit | Reg0x32[4]=1 | | 150 | | mV |
| | | Reg0x32[4]=0 | | 280 | | |
| VOCP_limit_SYSSH ORT_ACX | System Short or SRN<2.5 V | Reg0x32[4]=1 | | 90 | | mV |
| | | Reg0x32[4]=0 | | 150 | | |
| THERMAL SHUTDOWN COMPARATOR | | | | | | |
| $T_{\text{SHUT_RISE}}$ | Thermal shutdown rising temperature | Temperature increasing | | 155 | | $^\circ\text{C}$ |
| $T_{\text{SHUT_FALL}}$ | Thermal shutdown falling temperature | Temperature reducing | | 135 | | $^\circ\text{C}$ |
| $T_{\text{SHUT_HYS}}$ | Thermal shutdown hysteresis | | | 20 | | $^\circ\text{C}$ |
| $t_{\text{SHUT_RDEG}}$ | Thermal shutdown rising deglitch | | | 100 | | μs |
| $t_{\text{SHUT_FHYS}}$ | Thermal shutdown falling deglitch | | | 12 | | ms |
| VSYS PROCHOT COMPARATOR | | | | | | |
| $V_{\text{SYS_PROCHOT}}$ | V_{SYS} threshold falling threshold | Reg0x36[7:6] = 00, 1 s | | 2.85 | | V |
| | | Reg0x36[7:6] = 00, 2–4 s | | 5.75 | | V |
| | | Reg0x36[7:6] = 01, 1 s | 2.95 | 3.1 | 3.25 | V |
| | | Reg0x36[7:6] = 01, 2–4 s | 5.8 | 5.95 | 6.1 | V |
| | | Reg0x36[7:6] = 10, 1 s | | 3.3 | | V |
| | | Reg0x36[7:6] = 10, 2–4 s | | 6.25 | | V |
| | | Reg0x36[7:6] = 11, 1 s | | 3.5 | | V |
| Reg0x36[7:6] = 11, 2–4 s | | 6.5 | | V | | |
| $t_{\text{SYS_PRO_RISE_DEG}}$ | V_{SYS} rising deglitch for throttling | | | 8 | | μs |
| ICRIT PROCHOT COMPARATOR | | | | | | |
| $V_{\text{ICRIT_PRO}}$ | Input current rising threshold for throttling as 10% above ILIM2 (REG0x37[7:3]) | Reg0x37[7:3] = 00000 | 105% | 110% | 116% | |
| | | Reg0x37[7:3] = 01001 | 142% | 150% | 156% | |
| INOM PROCHOT COMPARATOR | | | | | | |
| $V_{\text{INOM_PRO}}$ | INOM rising threshold as 10% above IIN (REG0x0F/0E()) | | 105% | 110% | 116% | |
| IDCHG PROCHOT COMPARATOR | | | | | | |
| $V_{\text{IDCHG_PRO}}$ | IDCHG threshold for throttling for IDSCHG of 6 A | Reg0x39[7:2] = 001100 | | 6272 | | mA |
| | | | 95% | | 102% | |
| INDEPENDENT COMPARATOR | | | | | | |
| $V_{\text{INDEP_CMP}}$ | Independent comparator threshold | Reg0x30[7] = 1, CMPIN falling | 1.17 | 1.2 | 1.23 | V |
| | | Reg0x30[7] = 0, CMPIN falling | 2.27 | 2.3 | 2.33 | V |

Electrical Characteristics (continued)

over $T_J = -40$ to 125°C (unless otherwise noted)

| PARAMETER | | TEST CONDITIONS | MIN | TYP | MAX | UNIT |
|---|---|--|------|------|------|---------------|
| $V_{\text{INDEP_CMP_HYS}}$ | Independent comparator hysteresis | Reg0x06[6] = 0, CMPIN falling | | 100 | | mV |
| POWER MOSFET DRIVER | | | | | | |
| PWM OSCILLATOR AND RAMP | | | | | | |
| F_{SW} | PWM switching frequency | Reg0x01[1] = 0 | 1020 | 1200 | 1380 | kHz |
| | | Reg0x01[1] = 1 | 680 | 800 | 920 | kHz |
| BATFET GATE DRIVER (BATDRV) | | | | | | |
| $V_{\text{BATDRV_ON}}$ | Gate drive voltage on BATFET | | 8.5 | 10 | 11.5 | V |
| $V_{\text{BATDRV_DIODE}}$ | Drain-source voltage on BATFET during ideal diode operation | | | 30 | | mV |
| $R_{\text{BATDRV_ON}}$ | Measured by sourcing 10- μA current to BATDRV | | 3 | 4 | 6 | k Ω |
| $R_{\text{BATDRV_OFF}}$ | Measured by sinking 10- μA current from BATDRV | | | 1.2 | 2.1 | k Ω |
| PWM HIGH SIDE DRIVER (HIDRV Q1) | | | | | | |
| $R_{\text{DS_HI_ON_Q1}}$ | High side driver (HSD) turnon resistance | $V_{\text{BTST1}} - V_{\text{SW1}} = 5\text{ V}$ | | 6 | | Ω |
| $R_{\text{DS_HI_OFF_Q1}}$ | High side driver turnoff resistance | $V_{\text{BTST1}} - V_{\text{SW1}} = 5\text{ V}$ | | 1.3 | 2.2 | Ω |
| $V_{\text{BTST1_REFRESH}}$ | Bootstrap refresh comparator falling threshold voltage | $V_{\text{BTST1}} - V_{\text{SW1}}$ when low side refresh pulse is requested | 3.2 | 3.7 | 4.6 | V |
| PWM HIGH SIDE DRIVER (HIDRV Q4) | | | | | | |
| $R_{\text{DS_HI_ON_Q4}}$ | High side driver (HSD) turnon resistance | $V_{\text{BTST2}} - V_{\text{SW2}} = 5\text{ V}$ | | 6 | | Ω |
| $R_{\text{DS_HI_OFF_Q4}}$ | High side driver turnoff resistance | $V_{\text{BTST2}} - V_{\text{SW2}} = 5\text{ V}$ | | 1.5 | 2.4 | Ω |
| $V_{\text{BTST2_REFRESH}}$ | Bootstrap refresh comparator falling threshold voltage | $V_{\text{BTST2}} - V_{\text{SW2}}$ when low side refresh pulse is requested | 3.3 | 3.7 | 4.6 | V |
| PWM LOW SIDE DRIVER (LODRV Q2) | | | | | | |
| $R_{\text{DS_LO_ON_Q2}}$ | Low side driver (LSD) turnon resistance | $V_{\text{BTST1}} - V_{\text{SW1}} = 5.5\text{ V}$ | | 6 | | Ω |
| $R_{\text{DS_LO_OFF_Q2}}$ | Low side driver turnoff resistance | $V_{\text{BTST1}} - V_{\text{SW1}} = 5.5\text{ V}$ | | 1.7 | 2.6 | Ω |
| PWM LOW SIDE DRIVER (LODRV Q3) | | | | | | |
| $R_{\text{DS_LO_ON_Q3}}$ | Low side driver (LSD) turnon resistance | $V_{\text{BTST2}} - V_{\text{SW2}} = 5.5\text{ V}$ | | 7.6 | | Ω |
| $R_{\text{DS_LO_OFF_Q3}}$ | Low side driver turnoff resistance | $V_{\text{BTST2}} - V_{\text{SW2}} = 5.5\text{ V}$ | | 2.9 | 4.6 | Ω |
| INTERNAL SOFT START During Charge Enable | | | | | | |
| SSSTEP_DAC | Soft Start Step Size | | | 64 | | mA |
| SSSTEP_DAC | Soft Start Step Time | | | 8 | | μs |
| INTEGRATED BTST DIODE (D1) | | | | | | |
| $V_{\text{F_D1}}$ | Forward bias voltage | $I_{\text{F}} = 20\text{ mA}$ at 25°C | | 0.8 | | V |
| $V_{\text{R_D1}}$ | Reverse breakdown voltage | $I_{\text{R}} = 2\text{ }\mu\text{A}$ at 25°C | | | 20 | V |
| INTEGRATED BTST DIODE (D2) | | | | | | |
| $V_{\text{F_D2}}$ | Forward bias voltage | $I_{\text{F}} = 20\text{ mA}$ at 25°C | | 0.8 | | V |
| $V_{\text{R_D2}}$ | Reverse breakdown voltage | $I_{\text{R}} = 2\text{ }\mu\text{A}$ at 25°C | | | 20 | V |
| PWM DRIVERS TIMING | | | | | | |

Electrical Characteristics (continued)

 over $T_J = -40$ to 125°C (unless otherwise noted)

| PARAMETER | | TEST CONDITIONS | MIN | TYP | MAX | UNIT |
|---|--------------------------------|---|-------|-----|-------|------|
| INTERFACE | | | | | | |
| LOGIC INPUT (SDA, SCL, EN_OTG) | | | | | | |
| V_{IN_LO} | Input low threshold | I2C | | | 0.4 | V |
| V_{IN_HI} | Input high threshold | I2C | 1.3 | | | V |
| LOGIC OUTPUT OPEN DRAIN (SDA, CHRG_OK, CMPOUT) | | | | | | |
| V_{OUT_LO} | Output saturation voltage | 5-mA drain current | | | 0.4 | V |
| V_{OUT_LEAK} | Leakage current | $V = 7\text{ V}$ | -1 | | 1 | mA |
| LOGIC OUTPUT OPEN DRAIN SDA | | | | | | |
| $V_{OUT_LO_SDA}$ | Output Saturation Voltage | 5 mA drain current | | | 0.4 | V |
| $V_{OUT_LEAK_SDA}$ | Leakage Current | $V = 7\text{ V}$ | -1 | | 1 | mA |
| LOGIC OUTPUT OPEN DRAIN CHRG_OK | | | | | | |
| $V_{OUT_LO_CHRG_OK}$ | Output Saturation Voltage | 5 mA drain current | | | 0.4 | V |
| $V_{OUT_LEAK_CHRG_OK}$ | Leakage Current | $V = 7\text{ V}$ | -1 | | 1 | mA |
| LOGIC OUTPUT OPEN DRAIN CMPOUT | | | | | | |
| $V_{OUT_LO_CMPOUT}$ | Output Saturation Voltage | 5 mA drain current | | | 0.4 | V |
| $V_{OUT_LEAK_CMPOUT}$ | Leakage Current | $V = 7\text{ V}$ | -1 | | 1 | mA |
| LOGIC OUTPUT OPEN DRAIN (PROCHOT) | | | | | | |
| $V_{OUT_LO_PROCHOT}$ | Output saturation voltage | 50- Ω pullup to 1.05 V / 5-mA load | | | 300 | mV |
| $V_{OUT_LEAK_PROCHOT}$ | Leakage current | $V = 5.5\text{ V}$ | -1 | | 1 | mA |
| ANALOG INPUT (ILIM_HIZ) | | | | | | |
| V_{HIZ_LO} | Voltage to get out of HIZ mode | ILIM_HIZ pin rising | 0.8 | | | V |
| V_{HIZ_HIGH} | Voltage to enable HIZ mode | ILIM_HIZ pin falling | | | 0.4 | V |
| ANALOG INPUT (CELL_BATPRESZ) | | | | | | |
| V_{CELL_4S} | 4S | REGN = 6 V, as percentage of REGN | 68.4% | 75% | | |
| V_{CELL_3S} | 3S | REGN = 6 V, as percentage of REGN | 51.7% | 55% | 65% | |
| V_{CELL_2S} | 2S | REGN = 6 V, as percentage of REGN | 35% | 40% | 49.1% | |
| V_{CELL_1S} | 1S | REGN = 6 V, as percentage of REGN | 18.4% | 25% | 31.6% | |
| $V_{CELL_BATPRESZ_RISE}$ | Battery is present | | 18% | | | |
| $V_{CELL_BATPRESZ_FALL}$ | Battery is removed | CELL_BATPRESZ falling | | | 15% | |
| ANALOG INPUT (COMP1, COMP2) | | | | | | |
| I_{LEAK_COMP1} | COMP1 Leakage | | -120 | | 120 | nA |
| I_{LEAK_COMP2} | COMP2 Leakage | | -120 | | 120 | nA |

7.6 Timing Requirements

| | | MIN | TYP | MAX | UNIT |
|-----------------------------------|--|-----|-----|-----|---------------|
| I2C TIMING CHARACTERISTICS | | | | | |
| t_r | SCLK/SDATA rise time | | | 1 | μs |
| t_f | SCLK/SDATA fall time | | | 300 | ns |
| $t_{W(H)}$ | SCLK pulse width high | 4 | | 50 | μs |
| $t_{W(L)}$ | SCLK Pulse Width Low | 4.7 | | | μs |
| $t_{SU(STA)}$ | Setup time for START condition | 4.7 | | | μs |
| $t_{H(STA)}$ | START condition hold time after which first clock pulse is generated | 4 | | | μs |

Timing Requirements (接下页)

| | | MIN | TYP | MAX | UNIT |
|-----------------------------------|---|-----|-----|-----|---------|
| $t_{SU(DAT)}$ | Data setup time | 250 | | | ns |
| $t_{H(DTA)}$ | Data hold time | 300 | | | ns |
| $t_{SU(STOP)}$ | Setup time for STOP condition | 4 | | | μ s |
| $t_{(BUF)}$ | Bus free time between START and STOP condition | 4.7 | | | μ s |
| $F_{S(CL)}$ | Clock Frequency | 100 | | 400 | KHz |
| HOST COMMUNICATION FAILURE | | | | | |
| t_{BOOT} | Deglitch for watchdog reset signal | 10 | | | ms |
| t_{WDI} | Watchdog timeout period, ChargeOption() bit [6:5] = 01 ⁽¹⁾ | 35 | 44 | 53 | s |
| | Watchdog timeout period, ChargeOption() bit bit [6:5] = 10 ⁽¹⁾ | 70 | 88 | 105 | s |
| | Watchdog timeout period, ChargeOption() bit bit [6:5] = 11 ⁽¹⁾ (default) | 140 | 175 | 210 | s |

(1) User can adjust threshold via SMBus ChargeOption() REG0x01/00.

7.7 Typical Characteristics

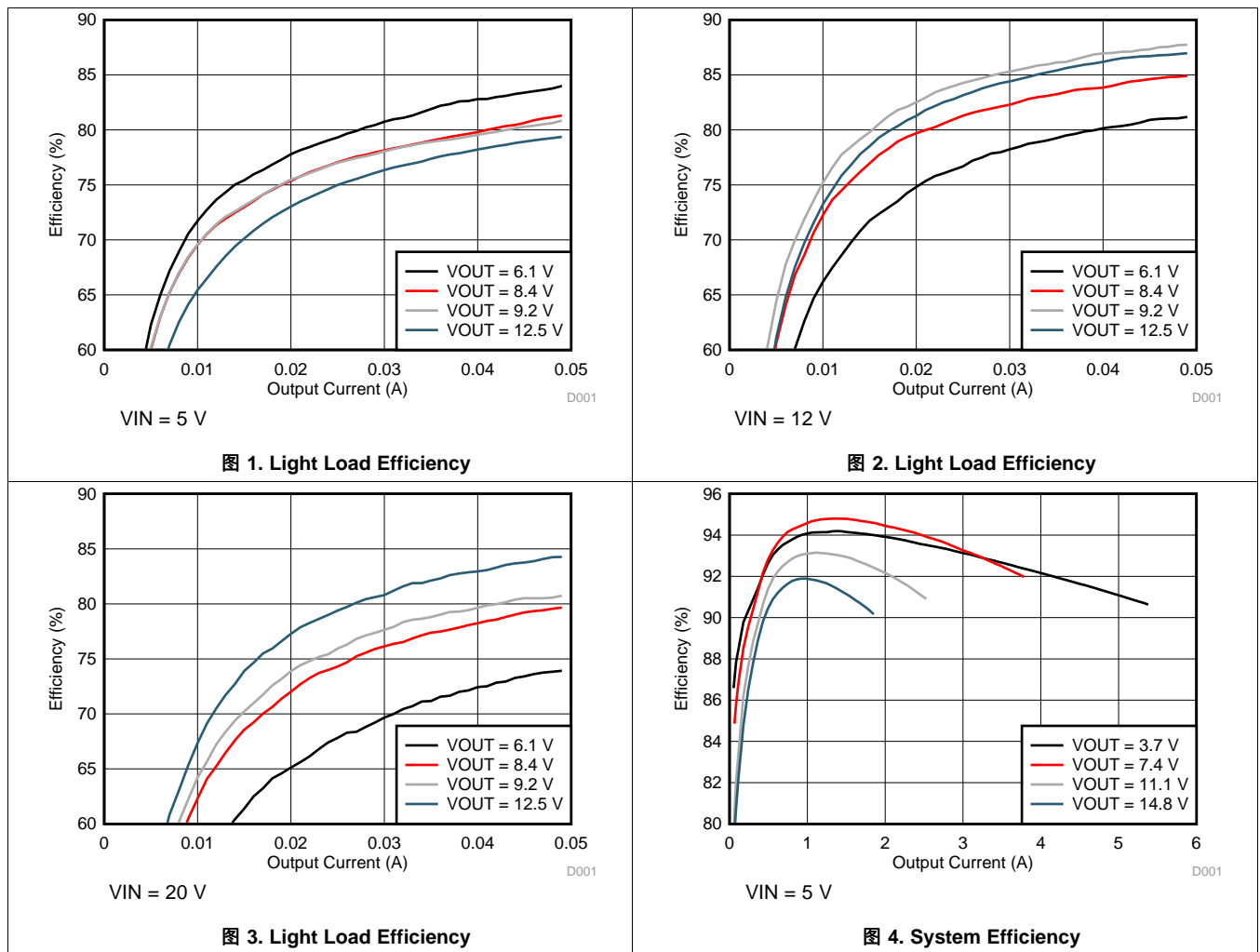

Typical Characteristics (接下页)

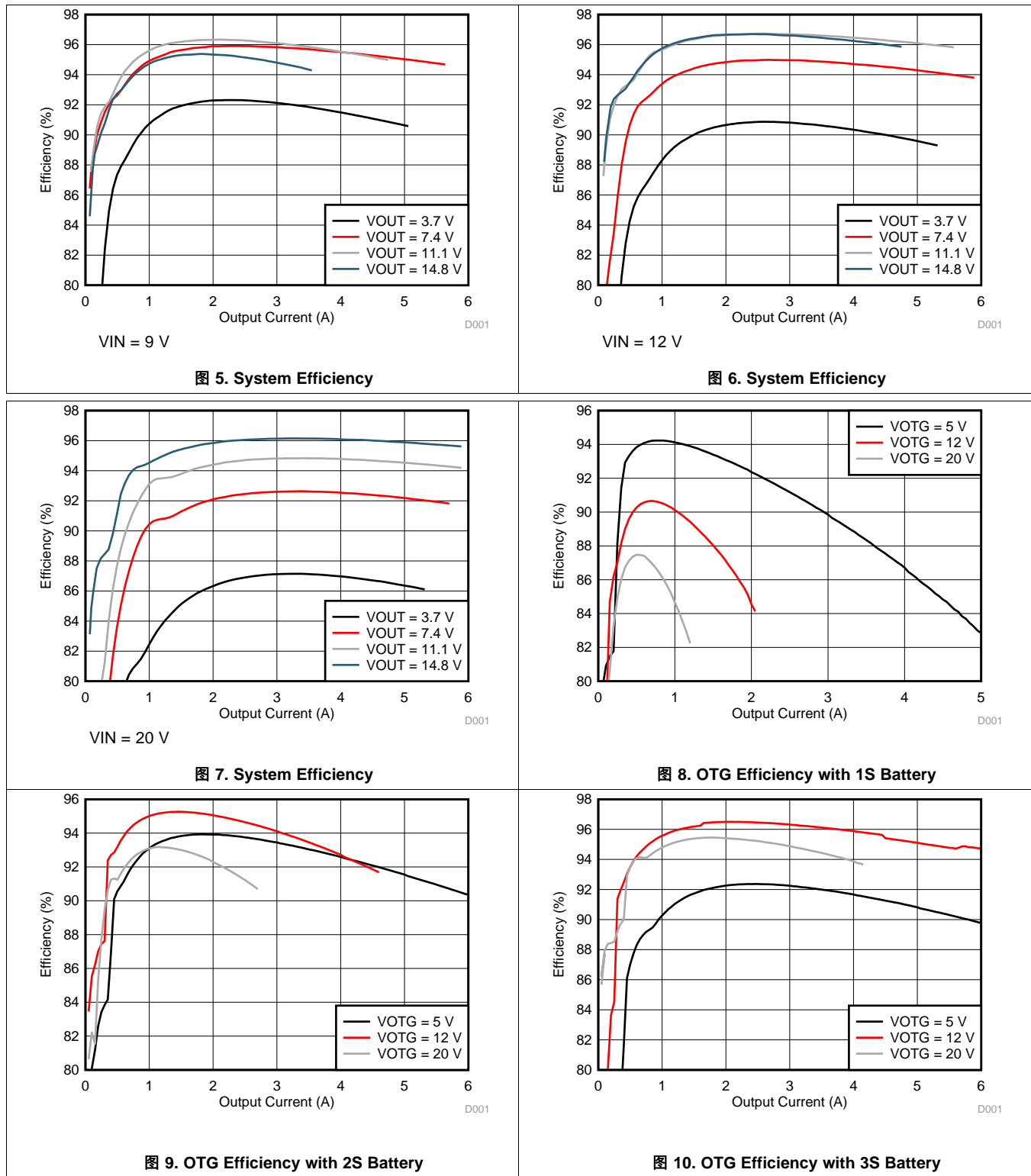

Typical Characteristics (接下页)



图 11. OTG Efficiency with 4S Battery

8 Detailed Description

8.1 Overview

The bq25703A is a buck boost NVDC (narrow voltage DC) charge controller for multi-chemistry portable applications such as notebook, detachable, ultrabook, tablet and other mobile devices with rechargeable batteries. It provides seamless transition between converter operation modes (buck, boost, or buck boost), fast transient response, and high light load efficiency.

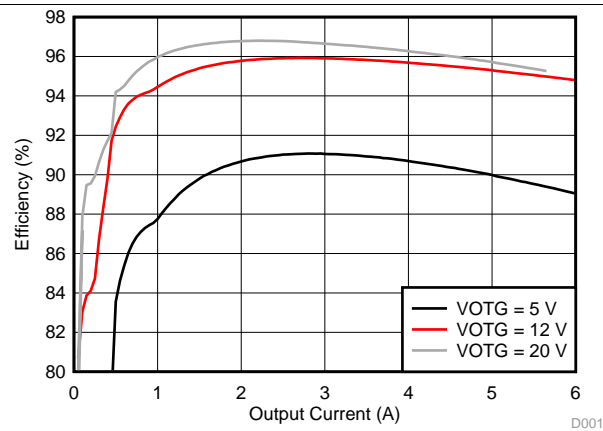
The bq25703A supports wide range of power sources, including USB PD ports, legacy USB ports, traditional AC-DC adapters, etc. It takes input voltage from 3.5 V to 24 V, and charges battery of 1-4 series. It also supports USB On-The-Go (OTG) to provide 4.48V to 20.8V output at USB port.

The bq25703A features Dynamic Power Management (DPM) to limit the input power and avoid AC adapter overloading. During battery charging, as the system power increases, the charging current will reduce to maintain total input current below adapter rating. If system power demand temporarily exceeds adapter rating, the bq25703A supports NVDC architecture to allow battery discharge energy to supplement system power. For details, refer to [System Voltage Regulation](#) section.

In order to be compliant with an Intel IMVP8 compliant system, the bq25703A includes PSYS function to monitor the total platform power from adapter and battery. Besides PSYS, it provides both an independent input current buffer (IADPT) and a battery current buffer (IBAT) with highly accurate current sense amplifiers. If the platform power exceeds the available power from adapter and battery, a $\overline{\text{PROCHOT}}$ signal is asserted to CPU so that the CPU optimizes its performance to the power available to the system.

The I2C controls input current, charge current and charge voltage registers with high resolution, high accuracy regulation limits. It also sets the $\overline{\text{PROCHOT}}$ timing and threshold profile to meet system requirements.

8.2 Functional Block Diagram

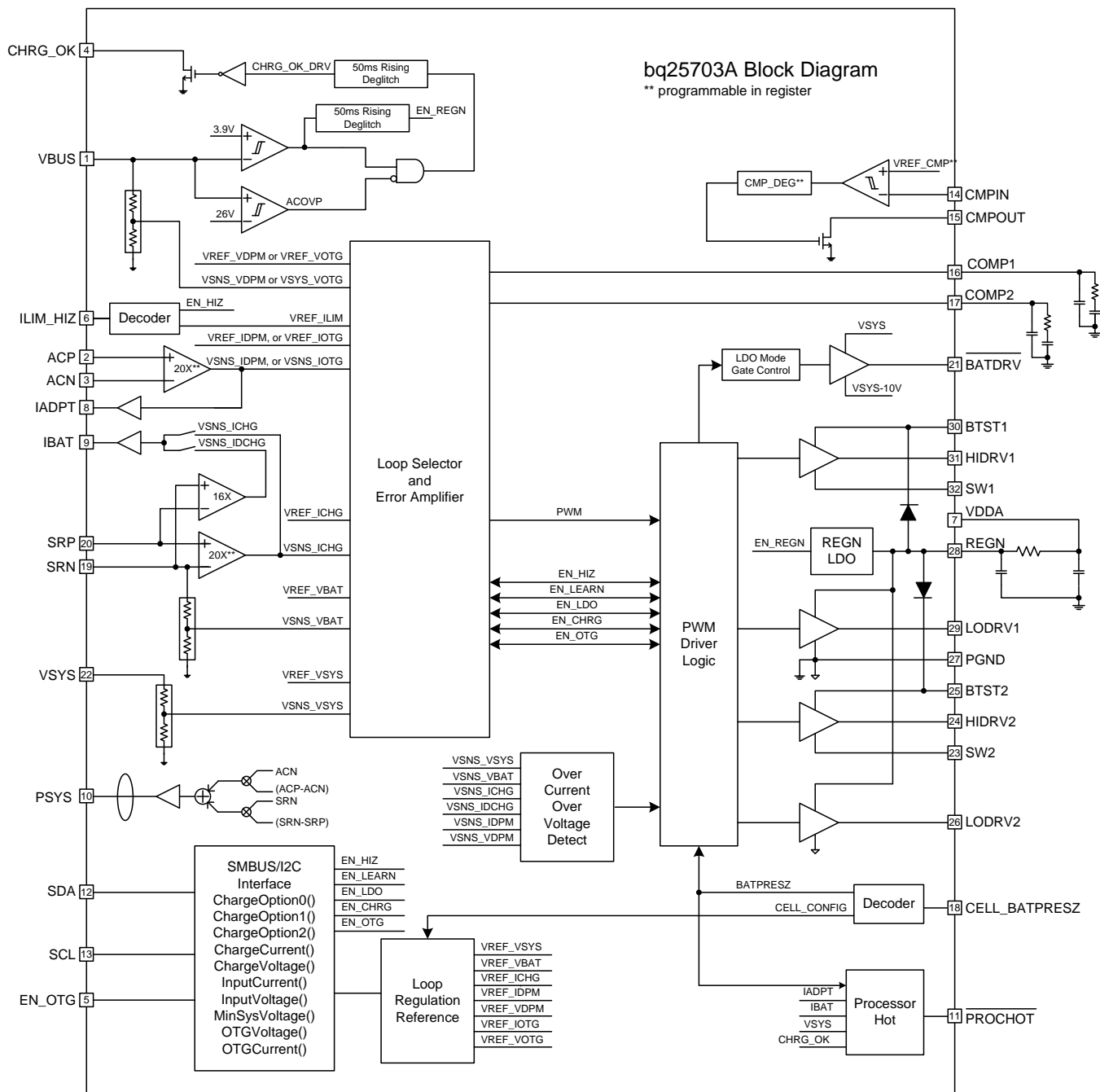

Copyright © 2017, Texas Instruments Incorporated

8.3 Feature Description

8.3.1 Power-Up from Battery Without DC Source

If only battery is present and the voltage is above V_{VBAT_UVLOZ} , the BATFET turns on and connects battery to system. By default, the charger is in low power mode ($REG0x01[7] = 1$) with lowest quiescent current. The LDO stays off. When device moves to performance mode ($REG0x01[7] = 0$), The host enables IBAT buffer through I2C to monitor discharge current. For PSYS, $\overline{PROCHOT}$ or independent comparator, REGN LDO is enabled for an accurate reference.

8.3.2 Power-Up From DC Source

When an input source plugs in, the charger checks the input source voltage to turn on LDO and all the bias circuits. It sets the input current limit before the converter starts.

The power-up sequence from DC source is as follows:

1. 50 ms after VBUS above V_{VBUS_CONVEN} , enable 6 V LDO and CHRГ_OK goes HIGH
2. Input voltage and current limit setup
3. Battery CELL configuration
4. 150 ms after VBUS above V_{VBUS_CONVEN} , converter powers up.

8.3.2.1 CHRГ_OK Indicator

CHRГ_OK is an active HIGH open drain indicator. It indicates the charger is in normal operation when the following conditions are valid:

- VBUS is above V_{VBUS_CONVEN}
- VBUS is below V_{ACOV}
- No MOSFET/inductor, or over-voltage, over-current, thermal shutdown fault

8.3.2.2 Input Voltage and Current Limit Setup

When CHRГ_OK goes LOW, the charger sets default input current limit in $REG0x0F/0E()$ to 3.30 A. The actual input current limit is the lower setting of $REG0x0F/0E()$ and ILIM_HIZ pin.

Charger initiates a VBUS voltage measurement without any load (VBUS at no load). The default VINDPM threshold is VBUS at no load – 1.28 V.

After input current and voltage limits are set, the charger device is ready to power up. The host can always update input current and voltage limit based on input source type.

8.3.2.3 Battery Cell Configuration

CELL_BATPRESZ pin is biased with resistors from REGN to CELL_BATPRESZ to GND. After VDDA LDO is activated, the device detects the battery configuration through CELL_BATPRESZ pin bias voltage. Refer to [Electrical Characteristics](#) for CELL setting thresholds.

表 1. Battery Cell Configuration

| CELL COUNT | PIN VOLTAGE w.r.t. VDDA | BATTERY VOLTAGE (REG0x15) | SYSOVP |
|------------|-------------------------|---------------------------|--------|
| 4S | 75% | 16.800V | 19.5V |
| 3S | 55% | 12.592V | 19.5V |
| 2S | 40% | 8.400V | 12V |
| 1S | 25% | 4.192V | 5V |

8.3.2.4 Device Hi-Z State

The charger enters Hi-Z mode when ILIM_HIZ pin voltage is below 0.4 V or $REG0x35[7]$ is set to 1. During Hi-Z mode, the input source is present, and the charger is in the low quiescent current mode with REGN LDO enabled.

8.3.3 USB On-The-Go (OTG)

The device supports USB OTG operation to deliver power from the battery to other portable devices through USB port. The OTG mode output voltage is set in REG0x07/06(). The OTG mode output current is set in REG0x09/08(). The OTG operation can be enabled if the conditions are valid:

- Valid battery voltage is set REG0x05/04()
- OTG output voltage is set in REG0x07/06() and output current is set in REG0x09/08()
- EN_OTG pin is HIGH and REG0x35[4] = 1
- VBUS is below V_{VBUS_UVLO}
- 10 ms after the above conditions are valid, converter starts and VBUS ramps up to target voltage. CHRГ_OK pin goes HIGH if REG0x01[3] = 1.

8.3.4 Converter Operation

The charger employs a synchronous buck-boost converter that allows charging from a standard 5-V or a high-voltage power source. The charger operates in buck, buck-boost and boost mode. The buck-boost can operate uninterruptedly and continuously across the three operation modes.

表 2. MOSFET Operation

| MODE | BUCK | BUCK-BOOST | BOOST |
|------|-----------|------------|-----------|
| Q1 | Switching | Switching | ON |
| Q2 | Switching | Switching | OFF |
| Q3 | OFF | Switching | Switching |
| Q4 | ON | Switching | Switching |

8.3.4.1 Inductor Setting through IADPT Pin

The charger reads the inductor value through the IADPT pin.

表 3. Inductor Setting on IADPT Pin

| INDUCTOR IN USE | RESISTOR ON IADPT PIN |
|-----------------|-----------------------|
| 1 μ H | 93 k Ω |
| 2.2 μ H | 137 k Ω |
| 3.3 μ H | 169 k Ω |

8.3.4.2 Continuous Conduction Mode (CCM)

With sufficient charge current, the inductor current does not cross 0 A, which is defined as CCM. The controller starts a new cycle with ramp coming up from 200 mV. As long as error amplifier output voltage is above the ramp voltage, the high-side MOSFET (HSFET) stays on. When the ramp voltage exceeds error amplifier output voltage, HSFET turns off and low-side MOSFET (LSFET) turns on. At the end of the cycle, ramp gets reset and LSFET turns off, ready for the next cycle. There is always break-before-make logic during transition to prevent cross-conduction and shoot-through. During the dead time when both MOSFETs are off, the body-diode of the low-side power MOSFET conducts the inductor current.

During CCM, the inductor current always flows and creates a fixed two-pole system. Having the LSFET turn-on when the HSFET is off keeps the power dissipation low and allows safe charging at high currents.

8.3.4.3 Pulse Frequency Modulation (PFM)

In order to improve converter light-load efficiency, the bq25703A switches to PFM control at light load. The effective switching frequency will decrease accordingly when system load decreases. The minimum frequency can be limit to 25 kHz (ChargeOption0() bit[10]=1).

8.3.5 Current and Power Monitor

8.3.5.1 High-Accuracy Current Sense Amplifier (IADPT and IBAT)

As an industry standard, a high-accuracy current sense amplifier (CSA) is used to monitor the input current during forward charging, or output current during OTG (IADPT) and the charge/discharge current (IBAT). IADPT voltage is 20× or 40× the differential voltage across ACP and ACN. IBAT voltage is 8×/16× (during charging), or 8×/16× (during discharging) of the differential across SRP and SRN. After input voltage or battery voltage is above UVLO, IADPT output becomes valid. To lower the voltage on current monitoring, a resistor divider from CSA output to GND can be used and accuracy over temperature can still be achieved.

- $V_{(IADPT)} = 20 \text{ or } 40 \times (V_{(ACP)} - V_{(ACN)})$ during forward mode, or $20 \text{ or } 40 \times (V_{(ACN)} - V_{(ACP)})$ during reverse OTG mode.
- $V_{(IBAT)} = 8 \text{ or } 16 \times (V_{(SRP)} - V_{(SRN)})$ during forward mode.
- $V_{(IBAT)} = 8 \text{ or } 16 \times (V_{(SRN)} - V_{(SRP)})$ during forward supplement mode, or reverse OTG mode.

A maximum 100-pF capacitor is recommended to connect on the output for decoupling high-frequency noise. An additional RC filter is optional, if additional filtering is desired. Note that adding filtering also adds additional response delay. The CSA output voltage is clamped at 3.3 V.

8.3.5.2 High-Accuracy Power Sense Amplifier (PSYS)

The charger monitors total system power. During forward mode, the input adapter powers system. During reverse OTG mode, the battery powers the system and VBUS output. The ratio of PSYS current and total power K_{PSYS} can be programmed in REG0x31[1] with default 1 $\mu\text{A/W}$. The input and charge sense resistors (RAC and RSR) are programmed in REG0x31[3:2]. PSYS voltage can be calculated with [公式 1](#) where IIN>0 when adapter is in forward charging, and IBAT>0 when the battery is in discharge when the battery is in discharge.

$$V_{PSYS} = R_{PSYS} \times K_{PSYS} (V_{ACP} \times I_{IN} + V_{BAT} \times I_{BAT}) \quad (1)$$

For proper PSYS functionality, RAC and RSR values are limited to 10 m Ω and 20 m Ω .

8.3.6 Input Source Dynamic Power Manage

Refer to [Input Current and Input Voltage Registers for Dynamic Power Management](#).

8.3.7 Two-Level Adapter Current Limit (Peak Power Mode)

Usually adapter can supply current higher than DC rating for a few milliseconds to tens of milliseconds. The charger employs two-level input current limit, or peak power mode, to fully utilize the overloading capability and minimize battery discharge during CPU turbo mode. Peak power mode is enabled in REG0x33[5](EN_PKPWR_IDPM) or REG0x33[4](EN_PKPWR_VSYS). The DC current limit, or I_{LIM1} , is the same as adapter DC current, set in REG0x0F/0E(). The overloading current, or I_{LIM2} , is set in REG0x37[7:3], as a percentage of I_{LIM1} .

When the charger detects input current surge and battery discharge due to load transient, it applies I_{LIM2} for $T_{OVL D}$ in REG0x33[7:6], first, and then I_{LIM1} for up to $T_{MAX} - T_{OVL D}$ time. T_{MAX} is programmed in REG0x33[1:0]. After T_{MAX} , if the load is still high, another peak power cycle starts. Charging is disabled during T_{MAX} ; once T_{MAX} expires, charging continues. If $T_{OVL D}$ is programmed higher than T_{MAX} , then peak power mode is always on.



图 12. Two-Level Adapter Current Limit Timing Diagram

8.3.8 Processor Hot Indication

When CPU is running turbo mode, the system peak power may exceed available power from adapter and battery together. The adapter current and battery discharge peak current, or system voltage drop is indication that system power is too high. The charger processor hot function monitors these events, and $\overline{\text{PROCHOT}}$ pulse is asserted. Once CPU receives $\overline{\text{PROCHOT}}$ pulse from charger, it slows down to reduce system power. The processor hot function monitors these events, and $\overline{\text{PROCHOT}}$ pulse is asserted.

The $\overline{\text{PROCHOT}}$ triggering events include:

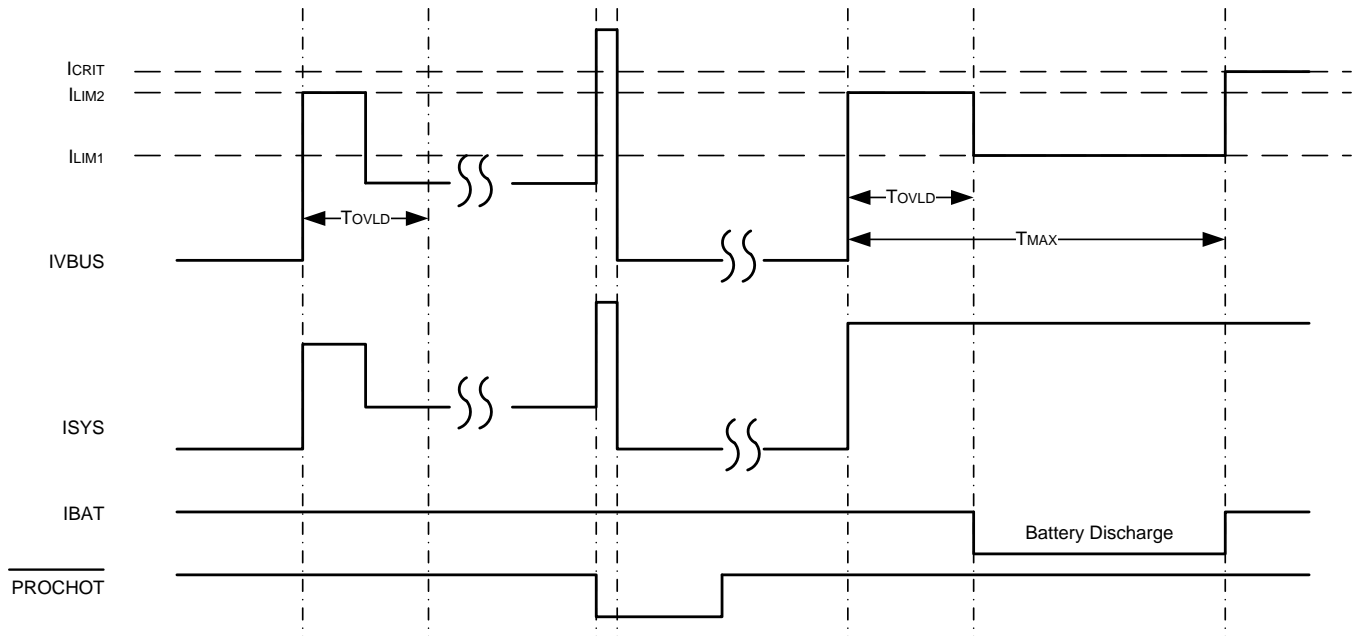
- ICRIT: adapter peak current, as 110% of I_{LIM2}
- INOM: adapter average current (110% of input current limit)
- IDCHG: battery discharge current
- VSYS: system voltage on VSYS
- Adapter Removal: upon adapter removal (CHRG_OK pin HIGH to LOW)
- Battery Removal: upon battery removal (CELL_BATPRESZ pin goes LOW)
- CMPOUT: Independent comparator output (CMPOUT pin HIGH to LOW)

The threshold of ICRIT, IDCHG or VSYS, and the deglitch time of ICRIT, INOM, IDCHG or CMPOUT are programmable through I2C. Each triggering event can be individually enabled in REG0x38[6:0]. When any event in $\overline{\text{PROCHOT}}$ profile is triggered, $\overline{\text{PROCHOT}}$ is asserted low for minimum 10 ms programmable in 0x36[4:3]. At the end of the 10 ms, if the $\overline{\text{PROCHOT}}$ event is still active, the pulse gets extended.

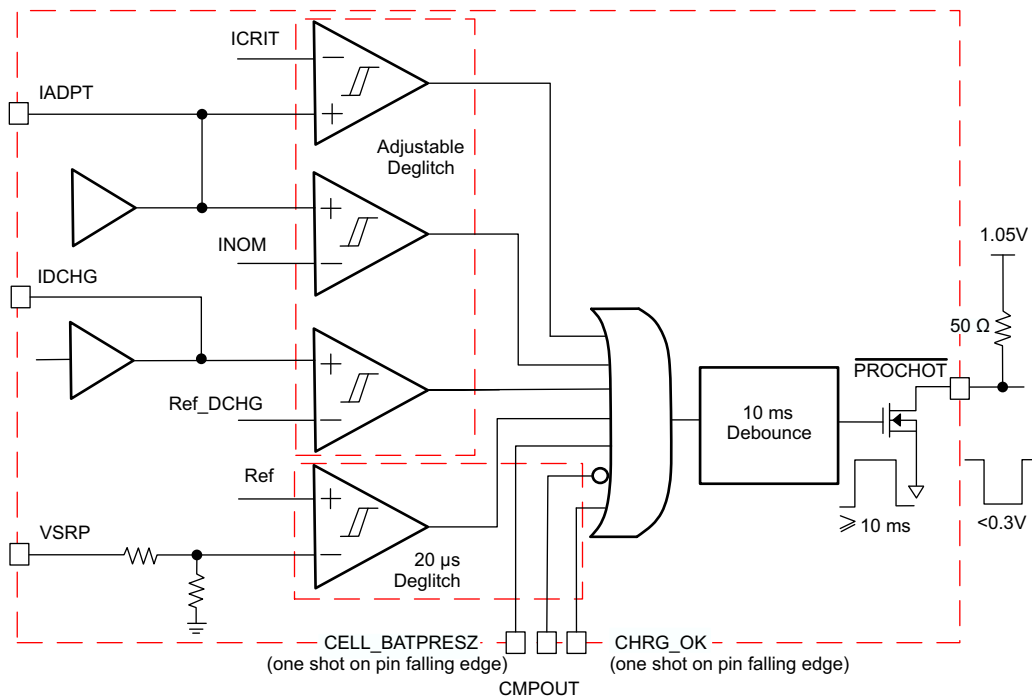

Copyright © 2017, Texas Instruments Incorporated

图 13. PROCHOT Profile

8.3.8.1 PROCHOT During Low Power Mode

During low power mode ($REG0x01[7] = 1$), the charger offers a low quiescent current ($\sim 150 \mu A$). Low power PROCHOT function uses the independent comparator to monitor battery discharge current and system voltage, and assert PROCHOT to CPU.

Below lists the register setting to enable PROCHOT during low power mode.

- $REG0x01[7] = 1$
- $REG0x38[5:0] = 000000$
- $REG0x30[6:4] = 100$
- Independent comparator threshold is always 1.2 V
- When $REG0x31[6] = 1$, charger monitors discharge current. Connect CMPIN to voltage proportional to IBAT pin. PROCHOT triggers from HIGH to LOW when CMPIN voltage falls below 1.2 V.
- When $REG0x31[5] = 1$, charger monitors system voltage. Connect CMPIN to voltage proportional to system. PROCHOT triggers from HIGH to LOW when CMPIN voltage rises above 1.2 V.

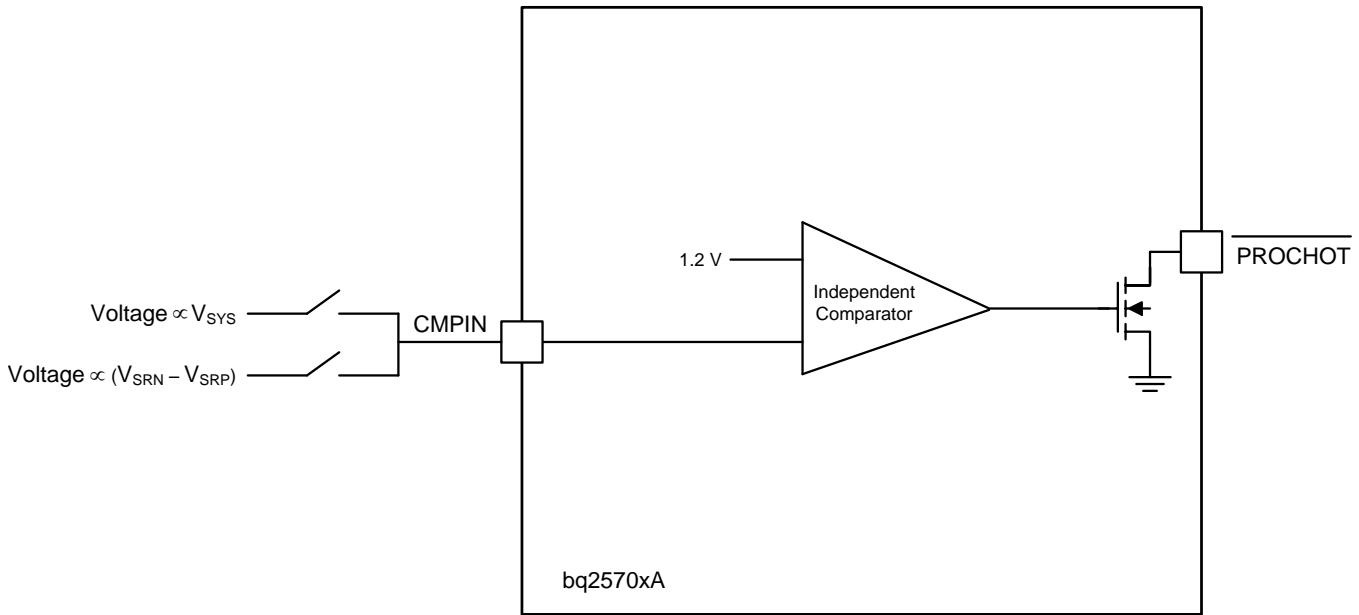

Copyright © 2017, Texas Instruments Incorporated

图 14. $\overline{\text{PROCHOT}}$ Low Power Mode Implementation

8.3.8.2 $\overline{\text{PROCHOT}}$ Status

REG0x22[6:0] reports which event in the profile triggers $\overline{\text{PROCHOT}}$ by setting the corresponding bit to 1. The status bit can be reset back to 0 after it is read by host, and current $\overline{\text{PROCHOT}}$ event is no longer active.

Assume there are two $\overline{\text{PROCHOT}}$ events, event A and event B. Event A triggers $\overline{\text{PROCHOT}}$ first, but event B is also active. Both status bits will be HIGH. At the end of the 10 ms $\overline{\text{PROCHOT}}$ pulse, if $\overline{\text{PROCHOT}}$ is still active (either by A or B), the $\overline{\text{PROCHOT}}$ pulse is extended.

8.3.9 Device Protection

8.3.9.1 Watchdog Timer

The charger includes watchdog timer to terminate charging if the charger does not receive a write MaxChargeVoltage() or write ChargeCurrent() command within 175 s (adjustable via REG0x01[6:5]). When watchdog timeout occurs, all register values are kept unchanged except ChargeCurrent() resets to zero. Battery charging is suspended. Write MaxChargeVoltage() or write ChargeCurrent() commands must be re-sent to reset watchdog timer and resume charging. Writing REG0x01[6:5] = 00 to disable watchdog timer also resumes charging.

8.3.9.2 Input Overvoltage Protection (ACOV)

The charger has fixed ACOV voltage. When VBUS pin voltage is higher than ACOV, it is considered as adapter over voltage. CHRГ_OK will be pulled low, and converter will be disabled. As system falls below battery voltage, BATFET will be turned on. When VBUS pin voltage falls below ACOV, it is considered as adapter voltage returns back to normal voltage. CHRГ_OK is pulled high by external pull up resistor. The converter resumes if enable conditions are valid.

8.3.9.3 Input Overcurrent Protection (ACOC)

If the input current exceeds the 1.25x or 2x (REG0x32[2]) of $I_{\text{LIM2_VTH}}$ (REG0x37[7:3]) set point, converter stops switching. After 300 ms, converter starts switching again.

8.3.9.4 System Overvoltage Protection (SYSOVP)

When the converter starts up, the bq25703A reads CELL pin configuration and sets MaxChargeVoltage() and SYSOVP threshold (1s – 5 V, 2s – 12 V, 3s/4s – 19.5 V). Before REGx05/04() is written by the host, the battery configuration will change with CELL pin voltage. When SYSOVP happens, the device latches off the converter. REG20[4] is set as 1. The user can clear latch-off by either writing 0 to the SYSOVP bit or removing and plugging in the adapter again. After latch-off is cleared, the converter starts again.

8.3.9.5 Battery Overvoltage Protection (BATOVP)

Battery over-voltage may happen when battery is removed during charging or the user plugs in a wrong battery. The BATOVP threshold is 104% (1 s) or 102% (2 s to 4 s) of regulation voltage set in REG0x05/04().

8.3.9.6 Battery Short

If BAT voltage falls below SYSMIN during charging, the maximum current is limited to 384 mA.

8.3.9.7 Thermal Shutdown (TSHUT)

The WQFN package has low thermal impedance, which provides good thermal conduction from the silicon to the ambient, to keep junction temperatures low. As added level of protection, the charger converter turns off for self-protection whenever the junction temperature exceeds the 155°C. The charger stays off until the junction temperature falls below 135°C. During thermal shut down, the LDO current limit is reduced to 16 mA and REGN LDO stays off. When the temperature falls below 135°C, charge can be resumed with soft start.

8.4 Device Functional Modes

8.4.1 Forward Mode

When input source is connected to VBUS, bq25703A is in forward mode to regulate system and charge battery.

8.4.1.1 System Voltage Regulation with Narrow VDC Architecture

The bq25703A employs Narrow VDC architecture (NVDC) with BATFET separating system from battery. The minimum system voltage is set by MinSystemVoltage(). Even with a deeply depleted battery, the system is regulated above the minimum system voltage.

When the battery is below minimum system voltage setting, the BATFET operates in linear mode (LDO mode).

As the battery voltage rises above the minimum system voltage, BATFET is fully on when charging or in supplement mode and the voltage difference between the system and battery is the VDS of BATFET. System voltage is regulated 160 mV above battery voltage when BATFET is off (no charging or no supplement current).

See [System Voltage Regulation](#) for details on system voltage regulation and register programming.

8.4.1.2 Battery Charging

The bq25703A charges 1-4 cell battery in constant current (CC), and constant voltage (CV) mode. Based on CELL_BATPREZ pin setting, the charger sets default battery voltage 4.2V/cell to ChargeVoltage(), or REG0x05/04(). According to battery capacity, the host programs appropriate charge current to ChargeCurrent(), or REG0x03/02(). When battery is full or battery is not in good condition to charge, host terminates charge by setting REG0x00[0] to 1, or setting ChargeCurrent() to zero.

See [Feature Description](#) for details on register programming.

8.4.2 USB On-The-Go

The bq25703A supports USB OTG functionality to deliver power from the battery to other portable devices through USB port (reverse mode). The OTG output voltage is compliant with USB PD specification, including 5 V, 9 V, 15 V, and 20 V (REG0x07/06()). The output current regulation is compliant with USB type C specification, including 500 mA, 1.5 A, 3 A and 5 A (REG0x09/08()).

Similar to forward operation, the device switches from PWM operation to PFM operation at light load to improve efficiency.

8.5 Programming

The charger supports battery-charger commands that use either Write-Word or Read-Word protocols, as summarized in 表 4. The I2C address is D6h (1101101_X), where X is the read/write bit. The ManufacturerID and DeviceID registers are assigned identify the charger device. The ManufacturerID register command always returns 40h.

8.5.1 I²C Serial Interface

The bq25703A uses I2C compatible interface for flexible charging parameter programming and instantaneous device status reporting. I²C is a bi-directional 2-wire serial interface. Only two bus lines are required: a serial data line (SDA) and a serial clock line (SCL). Devices can be considered as masters or slaves when performing data transfers. A master is the device which initiates a data transfer on the bus and generates the clock signals to permit that transfer. At that time, any device addressed is considered a slave.

The device operates as a slave device with address D6h, receiving control inputs from the master device like micro controller or a digital signal processor through REG00-REG0F. The I²C interface supports both standard mode (up to 100 kbits), and fast mode (up to 400 kbits). connecting to the positive supply voltage via a current source or pull-up resistor. When the bus is free, both lines are HIGH. The SDA and SCL pins are open drain.

8.5.1.1 Data Validity

The data on the SDA line must be stable during the HIGH period of the clock. The HIGH or LOW state of the data line can only change when the clock signal on the SCL line is LOW. One clock pulse is generated for each data bit transferred.



图 15. Bit Transfer on the I²C Bus

8.5.1.2 START and STOP Conditions

All transactions begin with a START (S) and can be terminated by a STOP (P). A HIGH to LOW transition on the SDA line while SCL is HIGH defines a START condition. A LOW to HIGH transition on the SDA line when the SCL is HIGH defines a STOP condition.

START and STOP conditions are always generated by the master. The bus is considered busy after the START condition, and free after the STOP condition.

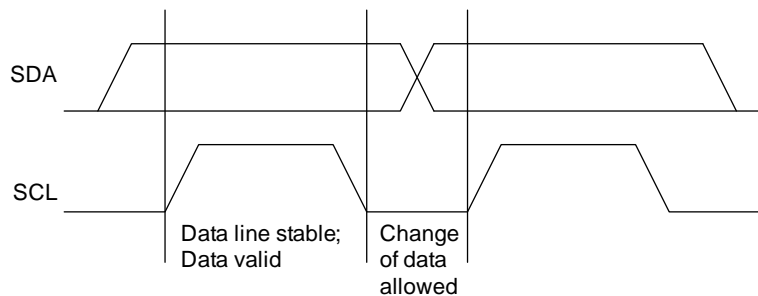

图 16. START and STOP Conditions

Programming (接下页)

8.5.1.3 Byte Format

Every byte on the SDA line must be 8 bits long. The number of bytes to be transmitted per transfer is unrestricted. Each byte has to be followed by an Acknowledge bit. Data is transferred with the Most Significant Bit (MSB) first. If a slave cannot receive or transmit another complete byte of data until it has performed some other function, it can hold the clock line SCL low to force the master into a wait state (clock stretching). Data transfer then continues when the slave is ready for another byte of data and release the clock line SCL.

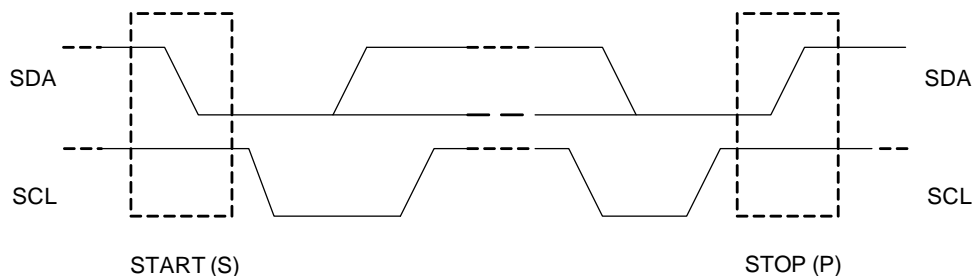

图 17. Data Transfer on the I²C Bus

8.5.1.4 Acknowledge (ACK) and Not Acknowledge (NACK)

The acknowledge takes place after every byte. The acknowledge bit allows the receiver to signal the transmitter that the byte was successfully received and another byte may be sent. All clock pulses, including the acknowledge 9th clock pulse, are generated by the master.

The transmitter releases the SDA line during the acknowledge clock pulse so the receiver can pull the SDA line LOW and it remains stable LOW during the HIGH period of this clock pulse.

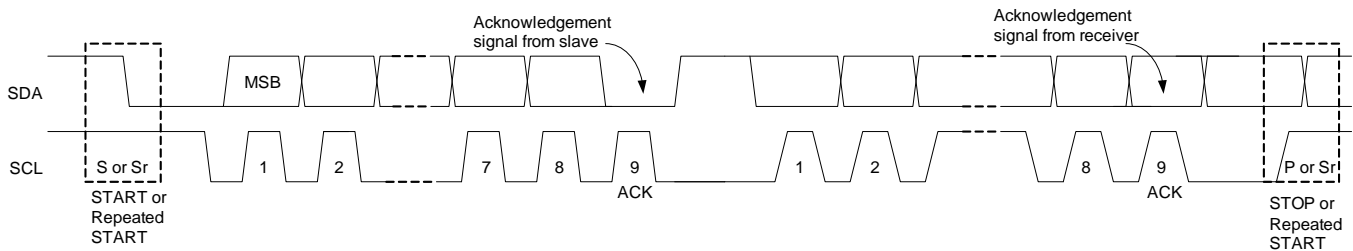
When SDA remains HIGH during the 9th clock pulse, this is the Not Acknowledge signal. The master can then generate either a STOP to abort the transfer or a repeated START to start a new transfer.

Programming (接下页)

8.5.1.5 Slave Address and Data Direction Bit

After the START, a slave address is sent. This address is 7 bits long followed by the eighth bit as a data direction bit (bit R/W). A zero indicates a transmission (WRITE) and a one indicates a request for data (READ).



图 18. Complete Data Transfer

8.5.1.6 Single Read and Write



图 19. Single Write

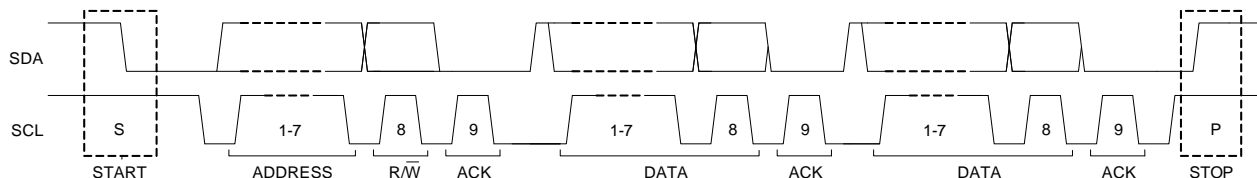

图 20. Single Read

If the register address is not defined, the charger IC send back NACK and go back to the idle state.

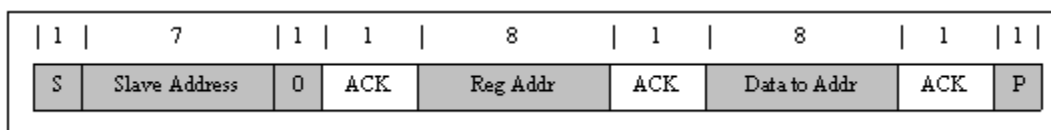
8.5.1.7 Multi-Read and Multi-Write

The charger device supports multi-read and multi-write.

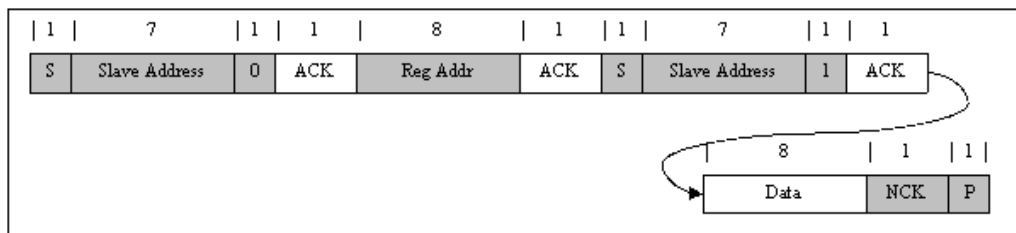

图 21. Multi Write

Programming (接下页)

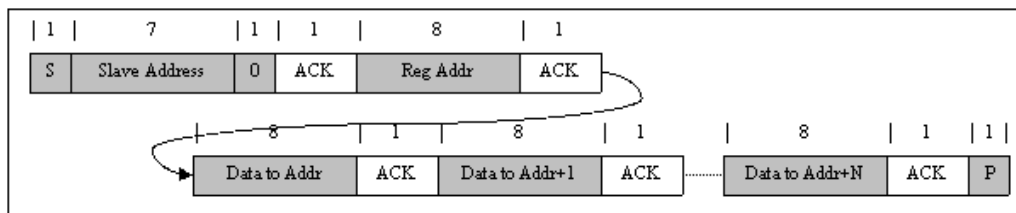

图 22. Multi Read

8.5.1.8 Write 2-Byte I2C Commands

A few I2C commands combine two 8-bit registers together to form a complete value. These commands include:

- ChargeCurrent()
- MaxChargeVoltage()
- IIN_DPM()
- OTGVoltage()
- InputVoltage()

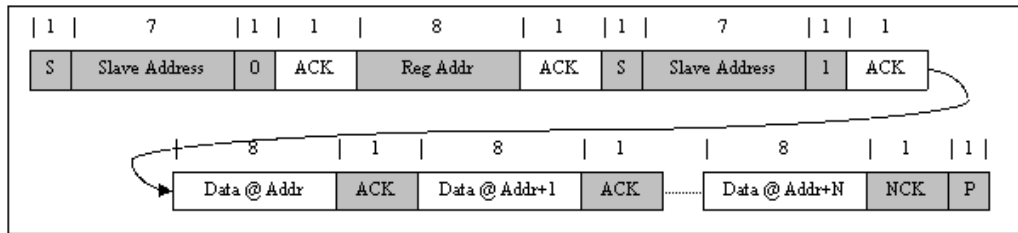
Host has to write LSB command followed by MSB command. No other command can be inserted in between these two writes. The charger waits for the complete write to the two registers to decide whether to accept or ignore the new value.

After the completion of LSB and MSB bytes, the two bytes will be updated at the same time. If host writes MSB byte first, the command will be ignored. If the time between write of LSB and MSB bytes exceeds watchdog timer, both the LSB and MSB commands will be ignored.

8.6 Register Map

表 4. Charger Command Summary

| I2C ADDR (MSB/LSB) | REGISTER NAME | TYPE | DESCRIPTION | LINKS |
|--------------------|--------------------|------|--|--------------------|
| 01/00h | ChargeOption0() | R/W | Charge Option 0 | Go |
| 03/02h | ChargeCurrent() | R/W | 7-bit charge current setting LSB 64 mA, Range 8128 mA | Go |
| 05/04h | MaxChargeVoltage() | R/W | 11-bit charge voltage setting LSB 16 mV, Default: 1S-4192mV, 2S-8400mV, 3S-12592mV, 4S-16800mV | Go |
| 31/30h | ChargeOption1() | R/W | Charge Option 1 | Go |
| 33/32h | ChargeOption2() | R/W | Charge Option 2 | Go |
| 35/34h | ChargeOption3() | R/W | Charge Option 3 | Go |
| 37/36h | ProchotOption0() | R/W | $\overline{\text{PROCHOT}}$ Option 0 | Go |
| 39/38h | ProchotOption1() | R/W | $\overline{\text{PROCHOT}}$ Option 1 | Go |
| 3B/3Ah | ADCOption() | R/W | ADC Option | Go |
| 21/20h | ChargerStatus() | R | Charger Status | Go |
| 23/22h | ProchotStatus() | R | Prochot Status | Go |
| 25/24h | IIN_DPM() | R | 7-bit input current limit in use LSB: 50 mA, Range: 50 mA - 6400 mA | Go |
| 27/26h | ADCVBUS/PSYS() | R | 8-bit digital output of input voltage, 8-bit digital output of system power PSYS: Full range: 3.06 V, LSB: 12 mV VBUS: Full range: 3.2 V - 19.52 V, LSB 64 mV | Go |

Register Map (接下页)
表 4. Charger Command Summary (接下页)

| I2C ADDR (MSB/LSB) | REGISTER NAME | TYPE | DESCRIPTION | LINKS |
|--------------------|--------------------|------|---|--------------------|
| 29/28h | ADCIBAT() | R | 8-bit digital output of battery charge current, 8-bit digital output of battery discharge current ICHG: Full range 8.128 A, LSB 64 mA IDCHG: Full range: 32.512 A, LSB: 256 mA | Go |
| 2B/2Ah | ADCIINCPIN() | R | 8-bit digital output of input current, 8-bit digital output of CMPIN voltage POR State - IIN: Full range: 12.75 A, LSB 50 mA CMPIN: Full range 3.06 V, LSB: 12 mV | Go |
| 2D/2Ch | ADCVSYSVBAT() | R | 8-bit digital output of system voltage, 8-bit digital output of battery voltage VSYS: Full range: 2.88 V - 19.2 V, LSB: 64 mV VBAT: Full range : 2.88 V - 19.2 V, LSB 64 mV | Go |
| 07/06h | OTGVoltage() | R/W | 8-bit OTG voltage setting LSB 64 mV, Range: 4480 – 20800 mV | Go |
| 09/08h | OTGCurrent() | R/W | 7-bit OTG output current setting LSB 50 mA, Range: 0 A – 6350 mA | Go |
| 0B/0Ah | InputVoltage() | R/W | 8-bit input voltage setting LSB 64 mV, Range: 3200 mV – 19520 mV | Go |
| 0D/0Ch | MinSystemVoltage() | R/W | 6-Bit minimum system voltage setting LSB: 256 mV, Range: 1024 mV - 16182 mV Default: 1S-3.584V, 2S-6.144V, 3S-9.216V, 4S-12.288V | Go |
| 0F/0Eh | IIN_HOST() | R/W | 6-bit Input current limit set by host LSB: 50-mA, Range: 50 mA - 6400 mA with 50 mA offset | Go |
| 2Eh | ManufacturerID() | R | Manufacturer ID - 0x0040H | Go |
| 2Fh | DeviceID() | R | Device ID | Go |

8.6.1 Setting Charge and PROCHOT Options

8.6.1.1 ChargeOption0 Register (I2C address = 01/00h) [reset = E20Eh]

图 23. ChargeOption0 Register (I2C address = 01/00h) [reset = E20Eh]

| | | | | | | | |
|----------|-----------|---|-------------------|---------------|--------|----------|--------------|
| 7 | 6 | 5 | 4 | 3 | 2 | 1 | 0 |
| EN_LWPWR | WDTMR_ADJ | | IDPM_AUTO_DISABLE | OTG_ON_CHRGOK | EN_OOA | PWM_FREQ | Reserved |
| R/W | R/W | | R/W | R/W | R/W | R/W | R/W |
| 7 | 6 | 5 | 4 | 3 | 2 | 1 | 0 |
| Reserved | EN_LEARN | | IADPT_GAIN | IBAT_GAIN | EN_LDO | EN_IDPM | CHRG_INHIBIT |
| R/W | R/W | | R/W | R/W | R/W | R/W | R/W |

LEGEND: R/W = Read/Write; R = Read only; -n = value after reset

表 5. ChargeOption0 Register (I2C address = 01h) Field Descriptions

| I2C 01h | FIELD | TYPE | RESET | DESCRIPTION |
|---------|-------------------|------|-------|---|
| 7 | EN_LWPWR | R/W | 1b | Low Power Mode Enable 0b: Disable Low Power Mode. Device in performance mode with battery only. The PROCHOT, current/power monitor buffer and comparator follow register setting. 1b: Enable Low Power Mode. Device in low power mode with battery only for lowest quiescent current. PROCHOT, discharge current monitor buffer, power monitor buffer and independent comparator are disabled. ADC is not available in Low Power Mode. Independent comparator can be enabled by setting either REG0X31()[6] or [5] to 1. <default at POR> |
| 6-5 | WDTMR_ADJ | R/W | 11b | WATCHDOG Timer Adjust Set maximum delay between consecutive I2C write of charge voltage or charge current command. If device does not receive a write on the REG0x05/04() or the REG0x03/02() within the watchdog time period, the charger will be suspended by setting the REG0x03/02() to 0 mA. After expiration, the timer will resume upon the write of REG0x03/02(), REG0x05/04() or REG0x01[6:5]. The charger will resume if the values are valid. 00b: Disable Watchdog Timer 01b: Enabled, 5 sec 10b: Enabled, 88 sec 11b: Enable Watchdog Timer, 175 sec <default at POR> |
| 4 | IDPM_AUTO_DISABLE | R/W | 0b | IDPM Auto Disable When CELL_BATPRESZ pin is LOW, the charger automatically disables the IDPM function by setting EN_IDPM (REG0x00[1]) to 0. The host can enable IDPM function later by writing EN_IDPM bit (REG0x00[1]) to 1. 0b: Disable this function. IDPM is not disabled when CELL_BATPRESZ goes LOW. <default at POR> 1b: Enable this function. IDPM is disabled when CELL_BATPRESZ goes LOW. |
| 3 | OTG_ON_CHRGOK | R/W | 0b | Add OTG to CHRG_OK Drive CHRG_OK to HIGH when the device is in OTG mode. 0b: Disable <default at POR> 1b: Enable |
| 2 | EN_OOA | R/W | 0b | Out-of-Audio Enable 0b: No limit of PFM burst frequency <default at POR> 1b: Set minimum PFM burst frequency to above 25 kHz to avoid audio noise |

表 5. ChargeOption0 Register (I2C address = 01h) Field Descriptions (接下页)

| I2C 01h | FIELD | TYPE | RESET | DESCRIPTION |
|---------|----------|------|-------|--|
| 1 | PWM_FREQ | R/W | 1b | Switching Frequency Two converter switching frequencies. One for small inductor and the other for big inductor. Recommend 800 kHz with 2.2 μ H or 3.3 μ H, and 1.2 MHz with 1 μ H or 1.5 μ H. Host has to set the right PWM frequency after device POR. 0b: 1200 kHz 1b: 800 kHz <default at POR> |
| 0 | Reserved | R/W | 0b | Reserved |

表 6. ChargeOption0 Register (I2C address = 00h) Field Descriptions

| I2C 00h | FIELD | TYPE | RESET | DESCRIPTION |
|---------|--------------|------|-------|--|
| 7-6 | Reserved | R/W | 00b | Reserved |
| 5 | EN_LEARN | R/W | 0b | LEARN function allows the battery to discharge while the adapter is present. It calibrates the battery gas gauge over a complete discharge/charge cycle. When the battery voltage is below battery depletion threshold, the system switches back to adapter input by the host. When CELL_BATPRESZ pin is LOW, the device exits LEARN mode and this bit is set back to 0. 0b: Disable LEARN Mode <default at POR> 1b: Enable LEARN Mode |
| 4 | IADPT_GAIN | R/W | 0b | IADPT Amplifier Ratio The ratio of voltage on IADPT and voltage across ACP and ACN. 0b: 20x <default at POR> 1b: 40x |
| 3 | IBAT_GAIN | R/W | 1b | IBAT Amplifier Ratio The ratio of voltage on IBAT and voltage across SRP and SRN 0b: 8x 1b: 16x <default at POR> |
| 2 | EN_LDO | R/W | 1b | LDO Mode Enable When battery voltage is below minimum system voltage (REG0x0D/0C()), the charger is in pre-charge with LDO mode enabled. 0b: Disable LDO mode, BATFET fully ON. Precharge current is set by battery pack internal resistor. The system is regulated by the MaxChargeVoltage register. 1b: Enable LDO mode, Precharge current is set by the ChargeCurrent register and clamped below 384 mA (2 cell – 4 cell) or 2A (1 cell). The system is regulated by the MinSystemVoltage register. <default at POR> |
| 1 | EN_IDPM | R/W | 1b | IDPM Enable Host writes this bit to enable IDPM regulation loop. When the IDPM is disabled by the charger (refer to IDPM_AUTO_DISABLE), this bit goes LOW. 0b: IDPM disabled 1b: IDPM enabled <default at POR> |
| 0 | CHRG_INHIBIT | R/W | 0b | Charge Inhibit When this bit is 0, battery charging will start with valid values in the MaxChargeVoltage register and the ChargeCurrent register. 0b: Enable Charge <default at POR> 1b: Inhibit Charge |

8.6.1.2 ChargeOption1 Register (I2C address = 31/30h) [reset = 211h]
图 24. ChargeOption1 Register (I2C address = 31/30h) [reset = 211h]

| | | | | | | | | | | | | | | | |
|---------|-----------------|---------|--|---------|----------------|----------|------------|--------------|----------------|---|--|---|--|---|--|
| 7 | | 6 | | 5 | | 4 | | 3 | | 2 | | 1 | | 0 | |
| EN_IBAT | EN_PROCHOT_LPWR | | | EN_PSYS | RSNS_RAC | RSNS_RSR | PSYS_RATIO | | Reserved | | | | | | |
| R/W | R/W | | | R/W | R/W | R/W | R/W | | R/W | | | | | | |
| 7 | | 6 | | 5 | | 4 | | 3 | | 2 | | 1 | | 0 | |
| CMP_REF | CMP_POL | CMP_DEG | | | FORCE_LATCHOFF | Reserved | | EN_SHIP_DCHG | AUTO_WAKEUP_EN | | | | | | |
| R/W | R/W | R/W | | | R/W | R/W | | R/W | R/W | | | | | | |

LEGEND: R/W = Read/Write; R = Read only; -n = value after reset

表 7. ChargeOption1 Register (I2C address = 31h) Field Descriptions

| I2C 31h | FIELD | TYPE | RESET | DESCRIPTION |
|---------|-----------------|------|-------|---|
| 7 | EN_IBAT | R/W | 0b | IBAT Enable Enable the IBAT output buffer. In low power mode (REG0x01[7] = 1), IBAT buffer is always disabled regardless of this bit value. 0b Turn off IBAT buffer to minimize Iq <default at POR> 1b: Turn on IBAT buffer |
| 6-5 | EN_PROCHOT_LPWR | R/W | 00b | Enable $\overline{\text{PROCHOT}}$ during battery only low power mode With battery only, enable IDCHG or VSYS in $\overline{\text{PROCHOT}}$ with low power consumption. Do not enable this function with adapter present. Refer to PROCHOT During Low Power Mode for more details. 00b: Disable low power $\overline{\text{PROCHOT}}$ <default at POR> 01b: Enable IDCHG low power $\overline{\text{PROCHOT}}$ 10b: Enable VSYS low power $\overline{\text{PROCHOT}}$ 11b: Reserved |
| 4 | EN_PSYS | R/W | 0b | PSYS Enable Enable PSYS sensing circuit and output buffer (whole PSYS circuit). In low power mode (REG0x01[7] = 1), PSYS sensing and buffer are always disabled regardless of this bit value. 0b: Turn off PSYS buffer to minimize Iq <default at POR> 1b: Turn on PSYS buffer |
| 3 | RSNS_RAC | R/W | 0b | Input sense resistor RAC 0b: 10 mΩ <default at POR> 1b: 20 mΩ |
| 2 | RSNS_RSR | R/W | 0b | Charge sense resistor RSR 0b: 10 mΩ <default at POR> 1b: 20 mΩ |
| 1 | PSYS_RATIO | R/W | 1b | PSYS Gain Ratio of PSYS output current vs total input and battery power with 10-mΩ sense resistor. 0b: 0.25 μA/W 1b: 1 μA/W <default at POR> |
| 0 | Reserved | R/W | 0b | Reserved |

表 8. ChargeOption1 Register (I2C address = 30h) Field Descriptions

| I2C 30h | FIELD | TYPE | RESET | DESCRIPTION |
|---------|---------|------|-------|---|
| 7 | CMP_REF | R/W | 0b | Independent Comparator Internal Reference. 0b: 2.3 V <default at POR> 1b: 1.2 V |

表 8. ChargeOption1 Register (I2C address = 30h) Field Descriptions (接下页)

| I2C 30h | FIELD | TYPE | RESET | DESCRIPTION |
|---------|----------------|------|-------|--|
| 6 | CMP_POL | R/W | 0b | Independent Comparator Output Polarity 0b: When CMPIN is above internal threshold, CMPOUT is LOW (internal hysteresis) <default at POR> 1b: When CMPIN is below internal threshold, CMPOUT is LOW (external hysteresis) |
| 5-4 | CMP_DEG | R/W | 01b | Independent Comparator Deglitch Time, only applied to the falling edge of CMPOUT (HIGH → LOW). 00b: Independent comparator is disabled 01b: Independent comparator is enabled with output deglitch time 1 μs <default at POR> 10b: Independent comparator is enabled with output deglitch time of 2 ms 11b: Independent comparator is enabled with output deglitch time of 5 sec |
| 3 | FORCE_LATCHOFF | R/W | 0b | Force Power Path Off When independent comparator triggers, charger turns off Q1 and Q4 (same as disable converter) so that the system is disconnected from the input source. At the same time, CHRG_OK signal goes to LOW to notify the system. 0b: Disable this function <default at POR> 1b: Enable this function |
| 2 | Reserved | R/W | 0b | Reserved |
| 1 | EN_SHIP_DCHG | R/W | 0b | Discharge SRN for Shipping Mode When this bit is 1, discharge SRN pin down below 3.8 V in 140 ms. When 140 ms is over, this bit is reset to 0. 0b: Disable shipping mode <default at POR> 1b: Enable shipping mode |
| 0 | AUTO_WAKEUP_EN | R/W | 1b | Auto Wakeup Enable When this bit is HIGH, if the battery is below minimum system voltage (REG0x0D/0C()), the device will automatically enable 128 mA charging current for 30 mins. When the battery is charged up above minimum system voltage, charge will terminate and the bit is reset to LOW. 0b: Disable 1b: Enable <default at POR> |

8.6.1.3 ChargeOption2 Register (I2C address = 33/32h) [reset = 2B7]
图 25. ChargeOption2 Register (I2C address = 33/32h) [reset = 2B7]

| | | | | | | | |
|-----------------|---------------|---------------|-----------------|------------------|-----------------|----------|-----------|
| 7 | 6 | 5 | 4 | 3 | 2 | 1 | 0 |
| PKPWR_TOVLD_DEG | EN_PKPWR_IDPM | EN_PKPWR_VSYS | PKPWR_OVLD_STAT | PKPWR_RELAX_STAT | PKPWR_TMAX[1:0] | | |
| R/W | R/W | R/W | R/W | R/W | R/W | R/W | |
| 7 | 6 | 5 | 4 | 3 | 2 | 1 | 0 |
| EN_EXTILIM | EN_ICHG_IDCHG | Q2_OCP | ACX_OCP | EN_ACOC | ACOC_VTH | EN_BATOC | BATOC_VTH |
| R/W | R/W | R/W | R/W | R/W | R/W | R/W | R/W |

LEGEND: R/W = Read/Write; R = Read only; -n = value after reset

表 9. ChargeOption2 Register (I2C address = 33h) Field Descriptions

| I2C 33h | FIELD | TYPE | RESET | DESCRIPTION |
|------------|------------------|------|-------|---|
| 7-6 | PKPWR_TOVLD_DEG | R/W | 00b | Input Overload time in Peak Power Mode 00b: 1 ms <default at POR> 01b: 2 ms 10b: 10 ms 11b: 20 ms |
| 5 | EN_PKPWR_IDPM | R/W | 0b | Enable Peak Power Mode triggered by input current overshoot If REG0x33[5:4] are 00b, peak power mode is disabled. Upon adapter removal, the bits are reset to 00b. 0b: Disable peak power mode triggered by input current overshoot <default at POR> 1b: Enable peak power mode triggered by input current overshoot. |
| 4 | EN_PKPWR_VSYS | R/W | 0b | Enable Peak Power Mode triggered by system voltage under-shoot If REG0x33[5:4] are 00b, peak power mode is disabled. Upon adapter removal, the bits are reset to 00b. 0b: Disable peak power mode triggered by system voltage under-shoot <default at POR> 1b: Enable peak power mode triggered by system voltage under-shoot. |
| 3 | PKPWR_OVLD_STAT | R/W | 0b | Indicator that the device is in overloading cycle. Write 0 to get out of overloading cycle. 0b: Not in peak power mode. <default at POR> 1b: In peak power mode. |
| 2 | PKPWR_RELAX_STAT | R/W | 0b | Indicator that the device is in relaxation cycle. Write 0 to get out of relaxation cycle. 0b: Not in relaxation cycle. <default at POR> 1b: In relaxation mode. |
| 1-0 | PKPWR_TMAX[1:0] | R/W | 10b | Peak power mode overload and relax cycle time. When REG0x33[7:6] is programmed longer than REG0x33[1:0], there is no relax time. 00b: 5 ms 01b: 10 ms 10b: 20 ms <default at POR> 11b: 40 ms |

表 10. ChargeOption2 Register (I2C address = 32h) Field Descriptions

| I2C 32h | FIELD | TYPE | RESET | DESCRIPTION |
|---------|---------------|------|-------|--|
| 7 | EN_EXTILIM | R/W | 1b | Enable ILIM_HIZ pin to set input current limit 0b: Input current limit is set by REG0x0F/0E. 1b: Input current limit is set by the lower value of ILIM_HIZ pin and REG0x0F/0E. <default at POR> |
| 6 | EN_ICHG_IDCHG | R/W | 0b | 0b: IBAT pin as discharge current. <default at POR> 1b: IBAT pin as charge current. |
| 5 | Q2_OCP | R/W | 1b | Q2 OCP threshold by sensing Q2 VDS 0b: 210 mV 1b: 150 mV <default at POR> |
| 4 | ACX_OCP | R/W | 1b | Input current OCP threshold by sensing ACP-ACN. 0b: 280 mV 1b: 150 mV <default at POR> |
| 3 | EN_ACOC | R/W | 0b | ACOC Enable Input overcurrent (ACOC) protection by sensing the voltage across ACP and ACN. Upon ACOC (after 100- μ s blank-out time), converter is disabled. 0b: Disable ACOC <default at POR> 1b: ACOC threshold 125% or 200% ICRIT |
| 2 | ACOC_VTH | R/W | 1b | ACOC Limit Set MOSFET OCP threshold as percentage of IDPM with current sensed from R _{AC} . 0b: 125% of ICRIT 1b: 210% of ICRIT <default at POR> |
| 1 | EN_BATOC | R/W | 1b | BATOC Enable Battery discharge overcurrent (BATOC) protection by sensing the voltage across SRN and SRP. Upon BATOC, converter is disabled. 0b: Disable BATOC 1b: BATOC threshold 125% or 200% $\overline{\text{PROCHOT}}$ IDCHG <default at POR> |
| 0 | BATOC_VTH | R/W | 1b | Set battery discharge overcurrent threshold as percentage of $\overline{\text{PROCHOT}}$ battery discharge current limit. 0b: 125% of $\overline{\text{PROCHOT}}$ IDCHG 1b: 200% of $\overline{\text{PROCHOT}}$ IDCHG <default at POR> |

8.6.1.4 ChargeOption3 Register (I2C address = 35/34h) [reset = 0h]
图 26. ChargeOption3 Register (I2C address = 35/34h) [reset = 0h]

| 7 | 6 | 5 | 4 | 3 | 2 | 1 | 0 |
|----------|-----------|--------------|--------|-------------|----------|---------------|----------------|
| EN_HIZ | RESET_REG | RESET_VINDPM | EN_OTG | EN_ICO_MODE | Reserved | | |
| R/W | R/W | R/W | R/W | R/W | R/W | | |
| 7 | 6 | 5 | 4 | 3 | 2 | 1 | 0 |
| Reserved | | | | | | BATFETOFF_HIZ | PSYS_OTG_IDCHG |
| R/W | | | | | | R/W | R/W |

LEGEND: R/W = Read/Write; R = Read only; -n = value after reset

表 11. ChargeOption3 Register (I2C address = 35h) Field Descriptions

| I2C 35h | FIELD | TYPE | RESET | DESCRIPTION |
|---------|--------------|------|-------|--|
| 7 | EN_HIZ | R/W | 0b | Device Hi-Z Mode Enable When the charger is in Hi-Z mode, the device draws minimal quiescent current. With VBUS above UVLO. REGN LDO stays on, and system powers from battery. 0b: Device not in Hi-Z mode <default at POR> 1b: Device in Hi-Z mode |
| 6 | RESET_REG | R/W | 0b | Reset Registers All the registers go back to the default setting except the VINDPM register. 0b: Idle <default at POR> 1b: Reset all the registers to default values. After reset, this bit goes back to 0. |
| 5 | RESET_VINDPM | R/W | 0b | Reset VINDPM Threshold 0b: Idle 1b: Converter is disabled to measure VINDPM threshold. After VINDPM measurement is done, this bit goes back to 0 and converter starts. |
| 4 | EN_OTG | R/W | 0b | OTG Mode Enable Enable device in OTG mode when EN_OTG pin is HIGH. 0b: Disable OTG <default at POR> 1b: Enable OTG mode to supply VBUS from battery. |
| 3 | EN_ICO_MODE | R/W | 0b | Enable ICO Algorithm 0b: Disable ICO algorithm. <default at POR> 1b: Enable ICO algorithm. |
| 2-0 | Reserved | R/W | 0b | Reserved |

表 12. ChargeOption3 Register (I2C address = 34h) Field Descriptions

| I2C 34h | FIELD | TYPE | RESET | DESCRIPTION |
|---------|----------------|------|-------|---|
| 7-2 | Reserved | R/W | 0b | Reserved |
| 1 | BATFETOFF_HIZ | R/W | 0b | Control BATFET during HIZ mode. 0b: BATFET on during Hi-Z <default at POR> 1b: BATFET off during Hi-Z |
| 0 | PSYS_OTG_IDCHG | R/W | 0b | PSYS function during OTG mode. 0b: PSYS as battery discharge power minus OTG output power <default at POR> 1b: PSYS as battery discharge power only |

8.6.1.5 ProchotOption0 Register (I2C address = 37/36h) [reset = 04A54h]
图 27. ProchotOption0 Register (I2C address = 37/36h) [reset = 04A54h]

| | | | | | |
|-----------|----------------|---------------|---------------|----------|----------|
| 7-3 | | | 2-1 | | 0 |
| ILIM2_VTH | | | ICRIT_DEG | | Reserved |
| R/W | | | R/W | | R/W |
| 7-6 | 5 | 4-3 | 2 | 1 | 0 |
| VSYS_VTH | EN_PROCHOT_EXT | PROCHOT_WIDTH | PROCHOT_CLEAR | INOM_DEG | Reserved |
| R/W | R/W | R/W | R/W | R/W | R/W |

LEGEND: R/W = Read/Write; R = Read only; -n = value after reset

表 13. ProchotOption0 Register (I2C address = 37h) Field Descriptions

| I2C 37h | FIELD | TYPE | RESET | DESCRIPTION |
|---------|-----------|------|--------|---|
| 7-3 | ILIM2_VTH | R/W | 01001b | I_{LIM2} Threshold 5 bits, percentage of IDPM in 0x0F/0EH. Measure current between ACP and ACN. Trigger when the current is above this threshold: 00001b - 11001b: 110% - 230%, step 5% 11010b - 11110b: 250% - 450%, step 50% 11111b: Out of Range (Ignored) Default 150%, or 01001 |
| 2-1 | ICRIT_DEG | R/W | 01b | ICRIT Deglitch time ICRIT is set to be 110% of I_{LIM2} . Typical ICRIT deglitch time to trigger $\overline{PROCHOT}$. 00b: 15 μ s 01b: 100 μ s <default at POR> 10b: 400 μ s (max 500 us) 11b: 800 μ s (max 1 ms) |
| 0 | Reserved | R/W | 0b | Reserved |

表 14. ProchotOption0 Register (I2C address = 36h) Field Descriptions

| I2C 36h | FIELD | TYPE | RESET | DESCRIPTION |
|---------|----------------|------|-------|---|
| 7-6 | VSYS_VTH | R/W | 01b | VSYS Threshold Measure on VSYS with fixed 20- μ s deglitch time. Trigger when SYS pin voltage is below the threshold. 00b: 5.75 V (2-4 s) or 2.85 V (1 s) 01b: 6 V (2-4 s) or 3.1 V (1 s) <default at POR> 10b: 6.25 V (2-4 s) or 3.35 V (1 s) 11b: 6.5 V (2-4 s) or 3.6 V (1 s) |
| 5 | EN_PROCHOT_EXT | R/W | 0b | $\overline{PROCHOT}$ Pulse Extension Enable When pulse extension is enabled, keep the $\overline{PROCHOT}$ pin voltage LOW until host writes 0x36[2] = 0. 0b: Disable pulse extension <default at POR> 1b: Enable pulse extension |
| 4-3 | PROCHOT_WIDTH | R/W | 10b | $\overline{PROCHOT}$ Pulse Width Minimum $\overline{PROCHOT}$ pulse width when REG0x36[5] = 0 00b: 100 μ s 01b: 1 ms 10b: 10 ms <default at POR> 11b: 5 ms |

表 14. ProchotOption0 Register (I2C address = 36h) Field Descriptions (接下页)

| I2C 36h | FIELD | TYPE | RESET | DESCRIPTION |
|---------|---------------|------|-------|---|
| 2 | PROCHOT_CLEAR | R/W | 1b | <p>$\overline{\text{PROCHOT}}$ Pulse Clear</p> <p>Clear $\overline{\text{PROCHOT}}$ pulse when 0x36[5] = 1.</p> <p>0b: Clear $\overline{\text{PROCHOT}}$ pulse and drive $\overline{\text{PROCHOT}}$ pin HIGH.</p> <p>1b: Idle <default at POR></p> |
| 1 | INOM_DEG | R/W | 0b | <p>INOM Deglitch Time</p> <p>INOM is always 10% above IDPM in 0x0F/0EH. Measure current between ACP and ACN.</p> <p>Trigger when the current is above this threshold.</p> <p>0b: 1 ms (must be max) <default at POR></p> <p>1b: 50 ms (max 60 ms)</p> |
| 0 | Reserved | R/W | 0b | Reserved |

8.6.1.6 ProchotOption1 Register (I2C address = 39/38h) [reset = 8120h]
图 28. ProchotOption1 Register (I2C address = 39/38h) [reset = 8120h]

| 7-2 | | | | | | 1-0 | |
|-----------|--------------------|----------|---------|----------|---------|------------|---------|
| IDCHG_VTH | | | | | | IDCHG_DEG | |
| R/W | | | | | | R/W | |
| 7 | 6 | 5 | 4 | 3 | 2 | 1 | 0 |
| Reserved | PROCHOT_PROFILE_IC | PP_ICRIT | PP_INOM | PP_IDCHG | PP_VSYS | PP_BATPRES | PP_ACOK |
| R/W | R/W | R/W | R/W | R/W | R/W | R/W | R/W |

LEGEND: R/W = Read/Write; R = Read only; -n = value after reset

表 15. ProchotOption1 Register (I2C address = 39h) Field Descriptions

| I2C 39h | FIELD | TYPE | RESET | DESCRIPTION |
|---------|-----------|------|---------|--|
| 7-2 | IDCHG_VTH | R/W | 100000b | IDCHG Threshold 6 bit, range, range 0 A to 32256 mA, step 512 mA. There is a 128 mA offset. Measure current between SRN and SRP. Trigger when the discharge current is above the threshold. If the value is programmed to 000000b, $\overline{\text{PROCHOT}}$ is always triggered. Default: 16384 mA or 100000b |
| 1-0 | IDCHG_DEG | R/W | 01b | IDCHG Deglitch Time 00b: 1.6 ms 01b: 100 μ s <default at POR> 10b: 6 ms 11b: 12 ms |

表 16. ProchotOption1 Register (I2C address = 38h) Field Descriptions

| I2C 38h | FIELD | TYPE | RESET | DESCRIPTION |
|---------|-------------------------|------|-------|---|
| 7 | Reserved | R/W | 0b | Reserved |
| 6 | PROCHOT_PROFILE_COMP | R/W | 0b | $\overline{\text{PROCHOT}}$ Profile When all the REG0x34[6:0] bits are 0, $\overline{\text{PROCHOT}}$ function is disabled. Bit6 Independent comparator 0b: disable <default at POR> 1b: enable |
| 5 | PROCHOT_PROFILE_ICRIT | R/W | 1b | 0b: disable 1b: enable <default at POR> |
| 4 | PROCHOT_PROFILE_INOM | R/W | 0b | 0b: disable <default at POR> 1b: enable |
| 3 | PROCHOT_PROFILE_IDCHG | R/W | 0b | 0b: disable <default at POR> 1b: enable |
| 2 | PROCHOT_PROFILE_VSYS | R/W | 0b | 0b: disable <default at POR> 1b: enable |
| 1 | PROCHOT_PROFILE_BATPRES | R/W | 0b | 0b: disable <default at POR> 1b: enable (one-shot falling edge triggered) If BATPRES is enabled in $\overline{\text{PROCHOT}}$ after the battery is removed, it will immediately send out one-shot $\overline{\text{PROCHOT}}$ pulse. |

表 16. ProchotOption1 Register (I2C address = 38h) Field Descriptions (接下页)

| I2C 38h | FIELD | TYPE | RESET | DESCRIPTION |
|------------|--------------------------|------|-------|--|
| 0 | PROCHOT _PROFILE_ACOK | R/W | 0b | 0b: disable <default at POR> 1b: enable ChargeOption0[15] = 0 to assert $\overline{\text{PROCHOT}}$ pulse after adapter removal. If PROCHOT_PROFILE_ACOK is enabled in $\overline{\text{PROCHOT}}$ after the adapter is removed, it will be pulled low. |

8.6.1.7 ADCOption Register (I2C address = 3B/3Ah) [reset = 2000h]
图 29. ADCOption Register (I2C address = 3B/3Ah) [reset = 2000h]

| 7 | | 6 | | 5 | | 4-0 | | | | | | | | | |
|--------------|--|-------------|--|---------------|--|------------|--|--------------|--|-------------|--|-------------|--|-------------|--|
| ADC_CONV | | ADC_START | | ADC_FULLSCALE | | Reserved | | | | | | | | | |
| R/W | | R/W | | R/W | | R/W | | | | | | | | | |
| 7 | | 6 | | 5 | | 4 | | 3 | | 2 | | 1 | | 0 | |
| EN_ADC_CMPIN | | EN_ADC_VBUS | | EN_ADC_PSYS | | EN_ADC_IIN | | EN_ADC_IDCHG | | EN_ADC_ICHG | | EN_ADC_VSYS | | EN_ADC_VBAT | |
| R/W | | R/W | | R/W | | R/W | | R/W | | R/W | | R/W | | R/W | |

LEGEND: R/W = Read/Write; R = Read only; -n = value after reset

The ADC registers are read in the following order: VBAT, VSYS, ICHG, IDCHG, IIN, PSYS, VBUS, CMPIN. ADC is disabled in low power mode. When enabling ADC, the device exit low power mode at battery only.

表 17. ADCOption Register (I2C address = 3Bh) Field Descriptions

| I2C 3Bh | FIELD | TYPE | RESET | DESCRIPTION |
|---------|---------------|------|--------|---|
| 7 | ADC_CONV | R/W | 0b | Typical ADC conversion time is 10 ms. 0b: One-shot update. Do one set of conversion updates to registers REG0x27/26(), REG0x29/28(), REG0x2B/2A(), and REG0x2D/2C() after ADC_START = 1. 1b: Continuous update. Do a set of conversion updates to registers REG0x27/26(), REG0x29/28(), REG0x2B/2A(), and REG0x2D/2C() every 1 sec. |
| 6 | ADC_START | R/W | 0b | 0b: No ADC conversion 1b: Start ADC conversion. After the one-shot update is complete, this bit automatically resets to zero |
| 5 | ADC_FULLSCALE | R/W | 1b | ADC input voltage range. When input voltage is below 5 V, or battery is 1S, full scale 2.04 V is recommended. 0b: 2.04 V 1b: 3.06 V <default at POR> |
| 4-0 | Reserved | R/W | 00000b | Reserved |

表 18. ADCOption Register (I2C address = 3Ah) Field Descriptions

| I2C 3Ah | FIELD | TYPE | RESET | DESCRIPTION |
|---------|--------------|------|-------|--|
| 7 | EN_ADC_CMPIN | R/W | 0b | 0b: Disable <default at POR> 1b: Enable |
| 6 | EN_ADC_VBUS | R/W | 0b | 0b: Disable <default at POR> 1b: Enable |
| 5 | EN_ADC_PSYS | R/W | 0b | 0b: Disable <default at POR> 1b: Enable |
| 4 | EN_ADC_IIN | R/W | 0b | 0b: Disable <default at POR> 1b: Enable |
| 3 | EN_ADC_IDCHG | R/W | 0b | 0b: Disable <default at POR> 1b: Enable |
| 2 | EN_ADC_ICHG | R/W | 0b | 0b: Disable <default at POR> 1b: Enable |
| 1 | EN_ADC_VSYS | R/W | 0b | 0b: Disable <default at POR> 1b: Enable |

表 18. ADCOption Register (I2C address = 3Ah) Field Descriptions (接下页)

| I2C 3Ah | FIELD | TYPE | RESET | DESCRIPTION |
|------------|-------------|------|-------|--|
| 0 | EN_ADC_VBAT | R/W | 0b | 0b: Disable <default at POR> 1b: Enable |

8.6.2 Charge and PROCHOT Status

8.6.2.1 ChargerStatus Register (I2C address = 21/20h) [reset = 0000h]

图 30. ChargerStatus Register (I2C address = 21/20h) [reset = 0000h]

| | | | | | | | |
|------------|-------------|------------|------------|-----------|----------------|---------------|---------------|
| 7 | 6 | 5 | 4 | 3 | 2 | 1 | 0 |
| AC_STAT | ICO_DONE | Reserved | IN_VINDPM | IN_IINDPM | IN_FCHRG | IN_PCHRG | IN_OTG |
| R | R | R | R | R | R | R | R |
| 7 | 6 | 5 | 4 | 3 | 2 | 1 | 0 |
| Fault ACOV | Fault BATOC | Fault ACOC | YSOVP_STAT | Reserved | Fault Latchoff | Fault_OTG_OVP | Fault_OTG_OCP |
| R | R | R | R | R | R | R | R |

LEGEND: R/W = Read/Write; R = Read only; -n = value after reset

表 19. ChargerStatus Register (I2C address = 21h) Field Descriptions

| I2C 21h | FIELD | TYPE | RESET | DESCRIPTION |
|---------|-----------|------|-------|--|
| 7 | AC_STAT | R | 0b | Input source status, same as CHRГ_OK pin 0b: Input not present 1b: Input is present |
| 6 | ICO_DONE | R | 0b | After the ICO routine is successfully executed, the bit goes 1. 0b: ICO is not complete 1b: ICO is complete |
| 5 | Reserved | R | 0b | Reserved |
| 4 | IN_VINDPM | R | 0b | 0b: Charger is not in VINDPM during forward mode, or voltage regulation during OTG mode 1b: Charger is in VINDPM during forward mode, or voltage regulation during OTG mode |
| 3 | IN_IINDPM | R | 0b | 0b: Charger is not in IINDPM 1b: Charger is in IINDPM |
| 2 | IN_FCHRG | R | 0b | 0b: Charger is not in fast charge 1b: Charger is in fast charger |
| 1 | IN_PCHRG | R | 0b | 0b: Charger is not in pre-charge 1b: Charger is in pre-charge |
| 0 | IN_OTG | R | 0b | 0b: Charger is not in OTG 1b: Charge is in OTG |

表 20. ChargerStatus Register (I2C address = 20h) Field Descriptions

| I2C 20h | FIELD | TYPE | RESET | DESCRIPTION |
|---------|-------------|------|-------|---|
| 7 | Fault ACOV | R | 0b | The faults are latched until a read from host. 0b: No fault 1b: ACOV |
| 6 | Fault BATOC | R | 0b | The faults are latched until a read from host. 0b: No fault 1b: BATOC |
| 5 | Fault ACOC | R | 0b | The faults are latched until a read from host. 0b: No fault 1b: ACOC |

表 20. ChargerStatus Register (I2C address = 20h) Field Descriptions (接下页)

| I2C 20h | FIELD | TYPE | RESET | DESCRIPTION |
|------------|----------------|------|-------|--|
| 4 | SYSOVP_STAT | R | 0b | SYSOVP Status and Clear When the SYSOVP occurs, this bit is HIGH. During the SYSOVP, the converter is disabled. After the SYSOVP is removed, the user must write a 0 to this bit or unplug the adapter to clear the SYSOVP condition to enable the converter again. 0b: Not in SYSOVP <default at POR> 1b: In SYSOVP. When SYSOVP is removed, write 0 to clear the SYSOVP latch. |
| 3 | Reserved | R | 0b | Reserved |
| 2 | Fault Latchoff | R | 0b | The faults are latched until a read from host. 0b: No fault 1b: Latch off (REG0x30[3]) |
| 1 | Fault_OTG_OVP | R | 0b | The faults are latched until a read from host. 0b: No fault 1b: OTG OVP |
| 0 | Fault_OTG_UCP | R | 0b | The faults are latched until a read from host. 0b: No fault 1b: OTG OCP |

8.6.2.2 ProchotStatus Register (I2C address = 23/22h) [reset = 0h]
图 31. ProchotStatus Register (I2C address = 23/22h) [reset = 0h]

| | | | | | | | |
|----------|-----------|------------|-----------|------------|-----------|--------------------------|--------------------------|
| 7-0 | | | | | | | |
| Reserved | | | | | | | |
| R | | | | | | | |
| 7 | 6 | 5 | 4 | 3 | 2 | 1 | 0 |
| Reserved | STAT_COMP | STAT_ICRIT | STAT_INOM | STAT_IDCHG | STAT_VSYS | STAT_Battery_ Removal | STAT_Adapter_ Removal |
| R | R | R | R | R | R | R | R |

LEGEND: R/W = Read/Write; R = Read only; -n = value after reset

表 21. ProchotStatus Register (I2C address = 23h) Field Descriptions

| I2C 23h | FIELD | TYPE | RESET | DESCRIPTION |
|------------|----------|------|-------|-------------|
| – | Reserved | R | 0b | Reserved |

表 22. ProchotStatus Register (I2C address = 22h) Field Descriptions

| I2C 22h | FIELD | TYPE | RESET | DESCRIPTION |
|------------|----------------------|------|-------|------------------------------------|
| – | Reserved | R | 0b | Reserved |
| 6 | STAT_COMP | R | 0b | 0b: Not triggered 1b: Triggered |
| 5 | STAT_ICRIT | R | 0b | 0b: Not triggered 1b: Triggered |
| 4 | STAT_INOM | R | 0b | 0b: Not triggered 1b: Triggered |
| 3 | STAT_IDCHG | R | 0b | 0b: Not triggered 1b: Triggered |
| 2 | STAT_VSYS | R | 0b | 0b: Not triggered 1b: Triggered |
| 1 | STAT_Battery_Removal | R | 0b | 0b: Not triggered 1b: Triggered |
| 0 | STAT_Adapter_Removal | R | 0b | 0b: Not triggered 1b: Triggered |

8.6.3 ChargeCurrent Register (I2C address = 03/02h) [reset = 0h]

To set the charge current, write a 16-bit ChargeCurrent() command (REG0x03/02h()) using the data format listed in 表 23 and 表 24.

With 10-mΩ sense resistor, the charger provides charge current range of 64 mA to 8.128 A, with a 64-mA step resolution. Upon POR, when auto wakeup is not active, ChargeCurrent() is 0 A. Any conditions for CHRГ_OK low except ACOV will reset ChargeCurrent() to zero. CELL_BATPRESZ going LOW (battery removal) will reset the ChargeCurrent() register to 0 A.

Charge current is not reset in ACOC, TSHUT, power path latch off (REG0x30[1]), and SYSOVP.

A 0.1-μF capacitor between SRP and SRN for differential mode filtering is recommended; an optional 0.1-μF capacitor between SRN and ground, and an optional 0.1-μF capacitor between SRP and ground for common mode filtering. Meanwhile, the capacitance on SRP should not be higher than 0.1 μF in order to properly sense the voltage across SRP and SRN for cycle-by-cycle current detection.

The SRP and SRN pins are used to sense voltage drop across RSR with default value of 10 mΩ. However, resistors of other values can also be used. For a larger sense resistor, a larger sense voltage is given, and a higher regulation accuracy; but, at the expense of higher conduction loss. A current sensing resistor value no more than 20 mΩ is suggested.

图 32. ChargeCurrent Register With 10-mΩ Sense Resistor (I2C address = 03/02h) [reset = 0h]

| | | | | | | | |
|-----------------------|-----------------------|----------|-----------------------|-----------------------|-----------------------|-----------------------|-----------------------|
| 7 | 6 | 5 | 4 | 3 | 2 | 1 | 0 |
| Reserved | | | Charge Current, bit 6 | Charge Current, bit 5 | Charge Current, bit 4 | Charge Current, bit 3 | Charge Current, bit 2 |
| R/W | | | R/W | R/W | R/W | R/W | R/W |
| 7 | 6 | 5 | 4 | 3 | 2 | 1 | 0 |
| Charge Current, bit 1 | Charge Current, bit 0 | Reserved | Reserved | | | | |
| R/W | R/W | R/W | R/W | | | | |

LEGEND: R/W = Read/Write; R = Read only; -n = value after reset

表 23. Charge Current Register (14h) With 10-mΩ Sense Resistor (I2C address = 03h) Field Descriptions

| I2C 03h | FIELD | TYPE | RESET | DESCRIPTION |
|---------|-----------------------|------|-------|---|
| 7-5 | Reserved | R/W | 000b | Not used. 1 = invalid write. |
| 4 | Charge Current, bit 6 | R/W | 0b | 0 = Adds 0 mA of charger current. 1 = Adds 4096 mA of charger current. |
| 3 | Charge Current, bit 5 | R/W | 0b | 0 = Adds 0 mA of charger current. 1 = Adds 2048 mA of charger current. |
| 2 | Charge Current, bit 4 | R/W | 0b | 0 = Adds 0 mA of charger current. 1 = Adds 1024 mA of charger current. |
| 1 | Charge Current, bit 3 | R/W | 0b | 0 = Adds 0 mA of charger current. 1 = Adds 512 mA of charger current. |
| 0 | Charge Current, bit 2 | R/W | 0b | 0 = Adds 0 mA of charger current. 1 = Adds 256 mA of charger current. |

表 24. Charge Current Register (14h) With 10-mΩ Sense Resistor (I2C address = 02h) Field Descriptions

| I2C 02h | FIELD | TYPE | RESET | DESCRIPTION |
|---------|-----------------------|------|---------|--|
| 7 | Charge Current, bit 1 | R/W | 0b | 0 = Adds 0 mA of charger current. 1 = Adds 128 mA of charger current. |
| 6 | Charge Current, bit 0 | R/W | 0b | 0 = Adds 0 mA of charger current. 1 = Adds 64 mA of charger current. |
| 5-0 | Reserved | R/W | 000000b | Not used. Value Ignored. |

8.6.3.1 Battery Pre-Charge Current Clamp

During pre-charge, BATFET works in linear mode or LDO mode (default REG0x00[2] = 1). For 2-4 cell battery, the system is regulated at minimum system voltage in REG0x0D/0C() and the pre-charge current is clamped at 384 mA. For 1 cell battery, the pre-charge to fast charge threshold is 3 V, and the pre-charge current is clamped at 384 mA. However, the BATFET stays in LDO mode operation till battery voltage is above minimum system voltage (~3.6 V). During battery voltage from 3 V to 3.6 V, the fast charge current is clamped at 2 A.

8.6.4 MaxChargeVoltage Register (I2C address = 05/04h) [reset value based on CELL_BATPRESZ pin setting]

To set the output charge voltage, write a 16-bit ChargeVoltage register command (REG0x05/04()) using the data format listed in 表 25 and 表 26. The charger provides charge voltage range from 1.024 V to 19.200 V, with 16-mV step resolution. Any write below 1.024 V or above 19.200 V is ignored.

Upon POR, REG0x05/04() is by default set as 4192 mV for 1 s, 8400 mV for 2 s, 12592 mV for 3 s or 16800 mV for 4 s. After CHRГ_OK, if host writes REG0x03/02() before REG0x05/04(), the charge will start after the write to REG0x03/02(). If the battery is different from 4.2 V/cell, the host has to write to REG0x05/04() before REG0x03/02() for correct battery voltage setting. Writing REG0x05/04() to 0 will set REG0x05/04() to default value on CELL_BATPRESZ pin, and force REG0x03/02() to zero to disable charge.

The SRN pin is used to sense the battery voltage for voltage regulation and should be connected as close to the battery as possible, and directly place a decoupling capacitor (0.1 μ F recommended) as close to the device as possible to decouple high frequency noise.

图 33. MaxChargeVoltage Register (I2C address = 05/04h) [reset value based on CELL_BATPRESZ pin setting]

| | | | | | | | | | | | | | | | |
|---------------------------|--|----------------------------|--|---------------------------|--|---------------------------|--|---------------------------|--|---------------------------|--|---------------------------|--|---------------------------|--|
| 7 | | 6 | | 5 | | 4 | | 3 | | 2 | | 1 | | 0 | |
| Reserved | | Max Charge Voltage, bit 10 | | Max Charge Voltage, bit 9 | | Max Charge Voltage, bit 8 | | Max Charge Voltage, bit 7 | | Max Charge Voltage, bit 6 | | Max Charge Voltage, bit 5 | | Max Charge Voltage, bit 4 | |
| R/W | | R/W | | R/W | | R/W | | R/W | | R/W | | R/W | | R/W | |
| 7 | | 6 | | 5 | | 4 | | 3 | | 2 | | 1 | | 0 | |
| Max Charge Voltage, bit 3 | | Max Charge Voltage, bit 2 | | Max Charge Voltage, bit 1 | | Max Charge Voltage, bit 0 | | Reserved | | | | | | | |
| R/W | | R/W | | R/W | | R/W | | R/W | | | | | | | |

LEGEND: R/W = Read/Write; R = Read only; -n = value after reset

表 25. MaxChargeVoltage Register (I2C address = 05h) Field Descriptions

| I2C 05h | FIELD | TYPE | RESET | DESCRIPTION |
|---------|----------------------------|------|-------|--|
| 7 | Reserved | R/W | 0b | Not used. 1 = invalid write. |
| 6 | Max Charge Voltage, bit 10 | R/W | 0b | 0 = Adds 0 mV of charger voltage. 1 = Adds 16384 mV of charger voltage. |
| 5 | Max Charge Voltage, bit 9 | R/W | 0b | 0 = Adds 0 mV of charger voltage. 1 = Adds 8192 mV of charger voltage |
| 4 | Max Charge Voltage, bit 8 | R/W | 0b | 0 = Adds 0 mV of charger voltage. 1 = Adds 4096 mV of charger voltage. |
| 3 | Max Charge Voltage, bit 7 | R/W | 0b | 0 = Adds 0 mV of charger voltage. 1 = Adds 2048 mV of charger voltage. |
| 2 | Max Charge Voltage, bit 6 | R/W | 0b | 0 = Adds 0 mV of charger voltage. 1 = Adds 1024 mV of charger voltage. |
| 1 | Max Charge Voltage, bit 5 | R/W | 0b | 0 = Adds 0 mV of charger voltage. 1 = Adds 512 mV of charger voltage. |
| 0 | Max Charge Voltage, bit 4 | R/W | 0b | 0 = Adds 0 mV of charger voltage. 1 = Adds 256 mV of charger voltage. |

表 26. MaxChargeVoltage Register (I2C address = 04h) Field Descriptions

| I2C 04h | FIELD | TYPE | RESET | DESCRIPTION |
|---------|---------------------------|------|-------|--|
| 7 | Max Charge Voltage, bit 3 | R/W | 0b | 0 = Adds 0 mV of charger voltage. 1 = Adds 128 mV of charger voltage. |
| 6 | Max Charge Voltage, bit 2 | R/W | 0b | 0 = Adds 0 mV of charger voltage. 1 = Adds 64 mV of charger voltage. |

表 26. MaxChargeVoltage Register (I2C address = 04h) Field Descriptions (接下页)

| I2C 04h | FIELD | TYPE | RESET | DESCRIPTION |
|------------|---------------------------|------|-------|---|
| 5 | Max Charge Voltage, bit 1 | R/W | 0b | 0 = Adds 0 mV of charger voltage. 1 = Adds 32 mV of charger voltage. |
| 4 | Max Charge Voltage, bit 0 | R/W | 0b | 0 = Adds 0 mV of charger voltage. 1 = Adds 16 mV of charger voltage. |
| 3-0 | Reserved | R/W | 0000b | Not used. Value Ignored. |

8.6.5 MinSystemVoltage Register (I2C address = 0D/0Ch) [reset value based on CELL_BATPRESZ pin setting]

To set the minimum system voltage, write a 16-bit MinSystemVoltage register command (REG0x0D/0C()) using the data format listed in 表 27 and 表 28. The charger provides minimum system voltage range from 1.024 V to 16.128 V, with 256-mV step resolution. Any write below 1.024 V or above 16.128 V is ignored. Upon POR, the MinSystemVoltage register is 3.584 V for 1 S, 6.144 V for 2 S and 9.216 V for 3 S, and 12.288 V for 4 S.

图 34. MinSystemVoltage Register (I2C address = 0D/0Ch) [reset value based on CELL_BATPRESZ pin setting]

| | | | | | | | |
|----------|---------------------------|---------------------------|---------------------------|---------------------------|---------------------------|---------------------------|---------------------------|
| 7 | 6 | 5 | 4 | 3 | 2 | 1 | 0 |
| Reserved | Min System Voltage, bit 5 | Min System Voltage, bit 4 | Min System Voltage, bit 3 | Min System Voltage, bit 2 | Min System Voltage, bit 1 | Min System Voltage, bit 0 | Min System Voltage, bit 0 |
| R/W | R/W | R/W | R/W | R/W | R/W | R/W | R/W |
| 7 | 6 | 5 | 4 | 3 | 2 | 1 | 0 |
| Reserved | | | | | | | |
| R/W | | | | | | | |

LEGEND: R/W = Read/Write; R = Read only; -n = value after reset

表 27. MinSystemVoltage Register (I2C address = 0Dh) Field Descriptions

| I2C 0Dh | FIELD | TYPE | RESET | DESCRIPTION |
|---------|---------------------------|------|-------|---|
| 7-6 | Reserved | R/W | 00b | Not used. 1 = invalid write. |
| 5 | Min System Voltage, bit 5 | R/W | 0b | 0 = Adds 0 mV of system voltage. 1 = Adds 8192 mV of system voltage. |
| 4 | Min System Voltage, bit 4 | R/W | 0b | 0 = Adds 0 mV of system voltage. 1 = Adds 4096mV of system voltage. |
| 3 | Min System Voltage, bit 3 | R/W | 0b | 0 = Adds 0 mV of system voltage. 1 = Adds 2048 mV of system voltage. |
| 2 | Min System Voltage, bit 2 | R/W | 0b | 0 = Adds 0 mV of system voltage. 1 = Adds 1024 mV of system voltage. |
| 1 | Min System Voltage, bit 1 | R/W | 0b | 0 = Adds 0 mV of system voltage. 1 = Adds 512 mV of system voltage. |
| 0 | Min System Voltage, bit 0 | R/W | 0b | 0 = Adds 0 mV of system voltage. 1 = Adds 256 mV of system voltage. |

表 28. MinSystemVoltage Register (I2C address = 0Ch) Field Descriptions

| I2C 0Ch | FIELD | TYPE | RESET | DESCRIPTION |
|---------|----------|------|---------------|--------------------------|
| 7-0 | Reserved | R/W | 0000000 0b | Not used. Value Ignored. |

8.6.5.1 System Voltage Regulation

The device employs Narrow VDC architecture (NVDC) with BATFET separating system from battery. The minimum system voltage is set by REG0x0D/0C(). Even with a deeply depleted battery, the system is regulated above the minimum system voltage with BATFET.

When the battery is below minimum system voltage setting, the BATFET operates in linear mode (LDO mode), and the system is regulated above the minimum system voltage setting. As the battery voltage rises above the minimum system voltage, BATFET is fully on when charging or in supplement mode and the voltage difference between the system and battery is the VDS of BATFET. System voltage is regulated 160 mV above battery voltage when BATFET is off (no charging or no supplement current).

When BATFET is removed, the system node VSYS is shorted to SRP. Before the converter starts operation, LDO mode needs to be disabled. The following sequence is required to configure charger without BATFET.

1. Before adapter plugs in, put the charger into HIZ mode. (either pull pin 6 ILIM_HIZ to ground, or set

- REG0x35[7] to 1)
2. Set 0x00[2] to 0 to disable LDO mode.
3. Set 0x30[0] to 0 to disable auto-wakeup mode.
4. Check if battery voltage is properly programmed (REG0x05/04)
5. Set pre-charge/charge current (REG0x03/02)
6. Put the device out of HIZ mode. (Release ILIM_HIZ from ground and set REG0x35[7]=0).

In order to prevent any accidental SW mistakes, the host sets low input current limit (a few hundred milliamps) when device is out of HIZ.

8.6.6 Input Current and Input Voltage Registers for Dynamic Power Management

The charger supports Dynamic Power Management (DPM). Normally, the input power source provides power for the system load or to charge the battery. When the input current exceeds the input current setting, or the input voltage falls below the input voltage setting, the charger decreases the charge current to provide priority to the system load. As the system current rises, the available charge current drops accordingly towards zero. If the system load keeps increasing after the charge current drops down to zero, the system voltage starts to drop. As the system voltage drops below the battery voltage, the battery will discharge to supply the heavy system load.

8.6.6.1 Input Current Registers

To set the maximum input current limit, write a 16-bit IIN_HOST register command (REG0x0F/0E()) using the data format listed in 表 29 and 表 30. When using a 10-mΩ sense resistor, the charger provides an input-current limit range of 50 mA to 6400 mA, with 50-mA resolution. The default current limit is 3.3 A. Due to the USB current setting requirement, the register setting specifies the maximum current instead of the typical current. Upon adapter removal, the input current limit is reset to the default value of 3.3 A. The register offset is 50 mA. With code 0, the input current limit is 50 mA.

The ACP and ACN pins are used to sense R_{AC} with the default value of 10 mΩ. For a 20-mΩ sense resistor, a larger sense voltage is given and a higher regulation accuracy, but at the expense of higher conduction loss.

Instead of using the internal DPM loop, the user can build up an external input current regulation loop and have the feedback signal on the ILIM_HIZ pin.

$$V_{ILIM_HIZ} = 1V + 40 \times (V_{ACP} - V_{ACN}) = 1 + 40 \times I_{DPM} \times R_{AC} \quad (2)$$

In order to disable ILIM_HIZ pin, the host can write to 0x32[7] to disable ILIM_HIZ pin, or pull ILIM_HIZ pin above 4.0 V.

8.6.6.1.1 IIN_HOST Register With 10-mΩ Sense Resistor (I2C address = 0F/0Eh) [reset = 4000h]

The register offset is 50 mA. With code 0, the input current limit readback is 50 mA.

图 35. IIN_HOST Register With 10-mΩ Sense Resistor (I2C address = 0F/0Eh) [reset = 4100h]

| 7 | 6 | 5 | 4 | 3 | 2 | 1 | 0 |
|----------|----------------------------------|----------------------------------|----------------------------------|----------------------------------|----------------------------------|----------------------------------|----------------------------------|
| Reserved | Input Current set by host, bit 6 | Input Current set by host, bit 5 | Input Current set by host, bit 4 | Input Current set by host, bit 3 | Input Current set by host, bit 2 | Input Current set by host, bit 1 | Input Current set by host, bit 0 |
| R/W | R/W | R/W | R/W | R/W | R/W | R/W | R/W |
| 7 | 6 | 5 | 4 | 3 | 2 | 1 | 0 |
| Reserved | | | | | | | |
| R | | | | | | | |

LEGEND: R/W = Read/Write; R = Read only; -n = value after reset

表 29. IIN_HOST Register With 10-mΩ Sense Resistor (I2C address = 0Fh) Field Descriptions

| I2C 0Fh | FIELD | TYPE | RESET | DESCRIPTION |
|---------|----------------------------------|------|-------|---|
| 7 | Reserved | R/W | 0b | Not used. 1 = invalid write. |
| 6 | Input Current set by host, bit 6 | R/W | 1b | 0 = Adds 0 mA of input current. 1 = Adds 3200 mA of input current. |
| 5 | Input Current set by host, bit 5 | R/W | 0b | 0 = Adds 0 mA of input current. 1 = Adds 1600 mA of input current. |
| 4 | Input Current set by host, bit 4 | R/W | 0b | 0 = Adds 0 mA of input current. 1 = Adds 800 mA of input current. |
| 3 | Input Current set by host, bit 3 | R/W | 0b | 0 = Adds 0 mA of input current. 1 = Adds 400 mA of input current. |
| 2 | Input Current set by host, bit 2 | R/W | 0b | 0 = Adds 0 mA of input current. 1 = Adds 200 mA of input current. |
| 1 | Input Current set by host, bit 1 | R/W | 0b | 0 = Adds 0 mA of input current. 1 = Adds 100 mA of input current. |
| 0 | Input Current set by host, bit 0 | R/W | 0b | 0 = Adds 0 mA of input current. 1 = Adds 50 mA of input current. |

表 30. IIN_HOST Register With 10-mΩ Sense Resistor (I2C address = 0Eh) Field Descriptions

| I2C 0Eh | FIELD | TYPE | RESET | DESCRIPTION |
|---------|----------|------|---------------|--------------------------|
| 7-0 | Reserved | R | 0000000 0b | Not used. Value Ignored. |

8.6.6.1.2 IIN_DPM Register With 10-mΩ Sense Resistor (I2C address = 25/24h) [reset = 0h]

IIN_DPM register reflects the actual input current limit programmed in the register, either from host or from ICO.

After ICO, the current limit used by DPM regulation may differ from the IIN_HOST register settings. The actual DPM limit is reported in REG0x25/24(). The register offset is 50 mA. With code 0, the input current limit read-back is 50 mA.

图 36. IIN_DPM Register With 10-mΩ Sense Resistor (I2C address = 25/24h) [reset = 0h]

| | | | | | | | |
|----------|-----------------------------|-----------------------------|-----------------------------|-----------------------------|-----------------------------|-----------------------------|-----------------------------|
| 7 | 6 | 5 | 4 | 3 | 2 | 1 | 0 |
| Reserved | Input Current in DPM, bit 6 | Input Current in DPM, bit 5 | Input Current in DPM, bit 4 | Input Current in DPM, bit 3 | Input Current in DPM, bit 2 | Input Current in DPM, bit 1 | Input Current in DPM, bit 0 |
| R | R | R | R | R | R | R | R |
| 7 | 6 | 5 | 4 | 3 | 2 | 1 | 0 |
| Reserved | | | | | | | |
| R | | | | | | | |

LEGEND: R/W = Read/Write; R = Read only; -n = value after reset

表 31. IIN_DPM Register With 10-mΩ Sense Resistor (I2C address = 25h) Field Descriptions

| I2C 25h | FIELD | TYPE | RESET | DESCRIPTION |
|---------|-----------------------------|------|-------|---|
| 7 | Reserved | R | 0b | Not used. 1 = invalid write. |
| 6 | Input Current in DPM, bit 6 | R | 0b | 0 = Adds 0 mA of input current. 1 = Adds 3200 mA of input current. |
| 5 | Input Current in DPM, bit 5 | R | 0b | 0 = Adds 0 mA of input current. 1 = Adds 1600 mA of input current. |
| 4 | Input Current in DPM, bit 4 | R | 0b | 0 = Adds 0 mA of input current. 1 = Adds 800mA of input current |
| 3 | Input Current in DPM, bit 3 | R | 0b | 0 = Adds 0 mA of input current. 1 = Adds 400 mA of input current. |
| 2 | Input Current in DPM, bit 2 | R | 0b | 0 = Adds 0 mA of input current. 1 = Adds 200 mA of input current. |
| 1 | Input Current in DPM, bit 1 | R | 0b | 0 = Adds 0 mA of input current. 1 = Adds 100 mA of input current. |
| 0 | Input Current in DPM, bit 0 | R | 0b | 0 = Adds 0 mA of input current. 1 = Adds 50 mA of input current. |

表 32. IIN_DPM Register With 10-mΩ Sense Resistor (I2C address = 24h) Field Descriptions

| I2C 24h | FIELD | TYPE | RESET | DESCRIPTION |
|---------|----------|------|-----------|--------------------------|
| 7-0 | Reserved | R | 00000000b | Not used. Value Ignored. |

8.6.6.1.3 InputVoltage Register (I2C address = 0B/0Ah) [reset = VBUS-1.28V]

To set the input voltage limit, write a 16-bit InputVoltage register command (REG0x0B/0A()) using the data format listed in 表 33 and 表 34.

If the input voltage drops more than the InputVoltage register allows, the device enters DPM and reduces the charge current. The default offset voltage is 1.28 V below the no-load VBUS voltage. The DC offset is 3.2 V (0000000).

图 37. InputVoltage Register (I2C address = 0B/0Ah) [reset = VBUS-1.28V]

| | | | | | | | |
|-------------------------|-------------------------|-------------------------|-------------------------|-------------------------|-------------------------|-------------------------|-------------------------|
| 7 | 6 | 5 | 4 | 3 | 2 | 1 | 0 |
| Reserved | | Input Voltage, bit 7 | Input Voltage, bit 6 | Input Voltage, bit 5 | Input Voltage, bit 4 | Input Voltage, bit 3 | Input Voltage, bit 2 |
| R/W | | R/W | R/W | R/W | R/W | R/W | R/W |
| 7 | 6 | 5 | 4 | 3 | 2 | 1 | 0 |
| Input Voltage, bit 1 | Input Voltage, bit 0 | Reserved | | | | | |
| R/W | R/W | R/W | | | | | |

LEGEND: R/W = Read/Write; R = Read only; -n = value after reset

表 33. InputVoltage Register (I2C address = 0Bh) Field Descriptions

| I2C 0Bh | FIELD | TYPE | RESET | DESCRIPTION |
|---------|----------------------|------|-------|---|
| 7-6 | Reserved | R/W | 00b | Not used. 1 = invalid write. |
| 5 | Input Voltage, bit 7 | R/W | 0b | 0 = Adds 0 mV of input voltage. 1 = Adds 8192 mV of input voltage. |
| 4 | Input Voltage, bit 6 | R/W | 0b | 0 = Adds 0 mV of input voltage. 1 = Adds 4096mV of input voltage. |
| 3 | Input Voltage, bit 5 | R/W | 0b | 0 = Adds 0 mV of input voltage. 1 = Adds 2048 mV of input voltage. |
| 2 | Input Voltage, bit 4 | R/W | 0b | 0 = Adds 0 mV of input voltage. 1 = Adds 1024 mV of input voltage. |
| 1 | Input Voltage, bit 3 | R/W | 0b | 0 = Adds 0 mV of input voltage. 1 = Adds 512 mV of input voltage. |
| 0 | Input Voltage, bit 2 | R/W | 0b | 0 = Adds 0 mV of input voltage. 1 = Adds 256 mV of input voltage. |

表 34. InputVoltage Register (I2C address = 0Ah) Field Descriptions

| I2C 0Ah | FIELD | TYPE | RESET | DESCRIPTION |
|---------|----------------------|------|---------|--|
| 7 | Input Voltage, bit 1 | R/W | 0b | 0 = Adds 0 mV of input voltage. 1 = Adds 128 mV of input voltage. |
| 6 | Input Voltage, bit 0 | R/W | 0b | 0 = Adds 0 mV of input voltage. 1 = Adds 64 mV of input voltage |
| 5-0 | Reserved | R/W | 000000b | Not used. Value Ignored. |

8.6.7 OTGVoltage Register (I2C address = 07/06h) [reset = 0h]

To set the OTG output voltage limit, write to REG0x07/06() using the data format listed in 表 35 and 表 36. The DC offset is 4.48 V (0000000).

图 38. OTGVoltage Register (I2C address = 07/06h) [reset = 0h]

| | | | | | | | | | | | | | | | |
|--------------------|--|--------------------|--|--------------------|--|--------------------|--|--------------------|--|--------------------|--|--------------------|--|--------------------|--|
| 7 | | 6 | | 5 | | 4 | | 3 | | 2 | | 1 | | 0 | |
| Reserved | | Reserved | | OTG Voltage, bit 7 | | OTG Voltage, bit 6 | | OTG Voltage, bit 5 | | OTG Voltage, bit 4 | | OTG Voltage, bit 3 | | OTG Voltage, bit 2 | |
| R/W | | R/W | | R/W | | R/W | | R/W | | R/W | | R/W | | R/W | |
| 7 | | 6 | | 5 | | 4 | | 3 | | 2 | | 1 | | 0 | |
| OTG Voltage, bit 1 | | OTG Voltage, bit 0 | | Reserved | | Reserved | | Reserved | | Reserved | | Reserved | | Reserved | |
| R/W | | R/W | | R/W | | R/W | | R/W | | R/W | | R/W | | R/W | |

LEGEND: R/W = Read/Write; R = Read only; -n = value after reset

表 35. OTGVoltage Register (I2C address = 07h) Field Descriptions

| I2C 07h | FIELD | TYPE | RESET | DESCRIPTION |
|---------|--------------------|------|-------|---|
| 7-6 | Reserved | R/W | 00b | Not used. 1 = invalid write. |
| 5 | OTG Voltage, bit 7 | R/W | 0b | 0 = Adds 0 mV of OTG voltage. 1 = Adds 8192 mV of OTG voltage. |
| 4 | OTG Voltage, bit 6 | R/W | 0b | 0 = Adds 0 mV of OTG voltage. 1 = Adds 4096 mV of OTG voltage. |
| 3 | OTG Voltage, bit 5 | R/W | 0b | 0 = Adds 0 mV of OTG voltage. 1 = Adds 2048 mV of OTG voltage. |
| 2 | OTG Voltage, bit 4 | R/W | 0b | 0 = Adds 0 mV of OTG voltage. 1 = Adds 1024 mV of OTG voltage. |
| 1 | OTG Voltage, bit 3 | R/W | 0b | 0 = Adds 0 mV of OTG voltage. 1 = Adds 512 mV of OTG voltage. |
| 0 | OTG Voltage, bit 2 | R/W | 0b | 0 = Adds 0 mV of OTG voltage. 1 = Adds 256 mV of OTG voltage. |

表 36. OTGVoltage Register (I2C address = 06h) Field Descriptions

| I2C 06h | FIELD | TYPE | RESET | DESCRIPTION |
|---------|--------------------|------|---------|--|
| 7 | OTG Voltage, bit 1 | R/W | 0b | 0 = Adds 0 mV of OTG voltage. 1 = Adds 128 mV of OTG voltage. |
| 6 | OTG Voltage, bit 0 | R/W | 0b | 0 = Adds 0 mV of OTG voltage. 1 = Adds 64 mV of OTG voltage. |
| 5-0 | Reserved | R/W | 000000b | Not used. Value Ignored. |

8.6.8 OTGCurrent Register (I2C address = 09/08h) [reset = 0h]

To set the OTG output current limit, write to REG0x09/08() using the data format listed in 表 37 and 表 38.

图 39. OTGCurrent Register (I2C address = 09/08h) [reset = 0h]

| 7 | 6 | 5 | 4 | 3 | 2 | 1 | 0 |
|----------|--------------------------------|--------------------------------|--------------------------------|--------------------------------|--------------------------------|--------------------------------|--------------------------------|
| Reserved | OTG Current set by host, bit 6 | OTG Current set by host, bit 5 | OTG Current set by host, bit 4 | OTG Current set by host, bit 3 | OTG Current set by host, bit 2 | OTG Current set by host, bit 1 | OTG Current set by host, bit 0 |
| R/W | R/W | R/W | R/W | R/W | R/W | R/W | R/W |
| 7 | 6 | 5 | 4 | 3 | 2 | 1 | 0 |
| Reserved | | | | | | | |
| R/W | | | | | | | |

LEGEND: R/W = Read/Write; R = Read only; -n = value after reset

表 37. OTGCurrent Register (I2C address = 09h) Field Descriptions

| I2C 09h | FIELD | TYPE | RESET | DESCRIPTION |
|---------|--------------------------------|------|-------|---|
| 7 | Reserved | R/W | 0b | Not used. 1 = invalid write. |
| 6 | OTG Current set by host, bit 6 | R/W | 0b | 0 = Adds 0 mA of OTG current. 1 = Adds 3200 mA of OTG current. |
| 5 | OTG Current set by host, bit 5 | R/W | 0b | 0 = Adds 0 mA of OTG current. 1 = Adds 1600mA of OTG current. |
| 4 | OTG Current set by host, bit 4 | R/W | 0b | 0 = Adds 0 mA of OTG current. 1 = Adds 800 mA of OTG current. |
| 3 | OTG Current set by host, bit 3 | R/W | 0b | 0 = Adds 0 mA of OTG current. 1 = Adds 400 mA of OTG current. |
| 2 | OTG Current set by host, bit 2 | R/W | 0b | 0 = Adds 0 mA of OTG current. 1 = Adds 200 mA of OTG current. |
| 1 | OTG Current set by host, bit 1 | R/W | 0b | 0 = Adds 0 mA of OTG current. 1 = Adds 100 mA of OTG current. |
| 0 | OTG Current set by host, bit 0 | R/W | 0b | 0 = Adds 0 mA of OTG current. 1 = Adds 50 mA of OTG current. |

表 38. OTGCurrent Register (I2C address = 08h) Field Descriptions

| I2C 08h | FIELD | TYPE | RESET | DESCRIPTION |
|---------|----------|------|-----------|--------------------------|
| 7-0 | Reserved | R/W | 00000000b | Not used. Value Ignored. |

8.6.9 ADCVBUS/PSYS Register (I2C address = 27/26h)

- PSYS: Full range: 3.06 V, LSB: 12 mV
- VBUS: Full range: 3200 mV to 19520 mV, LSB: 64 mV

图 40. ADCVBUS/PSYS Register (I2C address = 27/26h)

| | | | | | | | |
|---|---|---|---|---|---|---|---|
| 7 | 6 | 5 | 4 | 3 | 2 | 1 | 0 |
| R | R | R | R | R | R | R | R |
| 7 | 6 | 5 | 4 | 3 | 2 | 1 | 0 |
| R | R | R | R | R | R | R | R |

LEGEND: R/W = Read/Write; R = Read only; -n = value after reset

表 39. ADCVBUS/PSYS Register (I2C address = 27h) Field Descriptions

| BIT | FIELD | TYPE | RESET | DESCRIPTION |
|-----|-------|------|-------|---------------------------------------|
| 7-0 | | R | | 8-bit Digital Output of Input Voltage |

表 40. ADCVBUS/PSYS Register (I2C address = 26h) Field Descriptions

| BIT | FIELD | TYPE | RESET | DESCRIPTION |
|-----|-------|------|-------|--------------------------------------|
| 7-0 | | R | | 8-bit Digital Output of System Power |

8.6.10 ADCIBAT Register (I2C address = 29/28h)

- ICHG: Full range: 8.128 A, LSB: 64 mA
- IDCHG: Full range: 32.512 A, LSB: 256 mA

图 41. ADCIBAT Register (I2C address = 29/28h)

| | | | | | | | |
|----------|---|---|---|---|---|---|---|
| 7 | 6 | 5 | 4 | 3 | 2 | 1 | 0 |
| Reserved | R | R | R | R | R | R | R |
| 7 | 6 | 5 | 4 | 3 | 2 | 1 | 0 |
| Reserved | R | R | R | R | R | R | R |

LEGEND: R/W = Read/Write; R = Read only; -n = value after reset

表 41. ADCIBAT Register (I2C address = 29h) Field Descriptions

| BIT | FIELD | TYPE | RESET | DESCRIPTION |
|-----|----------|------|-------|--|
| 7 | Reserved | R | | Not used. Value ignored. |
| 6-0 | | R | | 7-bit Digital Output of Battery Charge Current |

表 42. ADCIBAT Register (I2C address = 28h) Field Descriptions

| BIT | FIELD | TYPE | RESET | DESCRIPTION |
|-----|----------|------|-------|---|
| 7 | Reserved | R | | Not used. Value ignored. |
| 6-0 | | R | | 7-bit Digital Output of Battery Discharge Current |

8.6.11 ADIINCMPIN Register (I2C address = 2B/2Ah)

- IIN: Full range: 12.75 A, LSB: 50 mA
- CMPIN: Full range: 3.06 V, LSB: 12 mV

图 42. ADIINCMPIN Register (I2C address = 2B/2Ah)

| | | | | | | | |
|---|---|---|---|---|---|---|---|
| 7 | 6 | 5 | 4 | 3 | 2 | 1 | 0 |
| R | R | R | R | R | R | R | R |
| 7 | 6 | 5 | 4 | 3 | 2 | 1 | 0 |
| R | R | R | R | R | R | R | R |

LEGEND: R/W = Read/Write; R = Read only; -n = value after reset

表 43. ADIINCMPIN Register (I2C address = 2Bh) Field Descriptions

| BIT | FIELD | TYPE | RESET | DESCRIPTION |
|-----|-------|------|-------|---------------------------------------|
| 7-0 | | R | | 8-bit Digital Output of Input Current |

表 44. ADIINCMPIN Register (I2C address = 2Ah) Field Descriptions

| BIT | FIELD | TYPE | RESET | DESCRIPTION |
|-----|-------|------|-------|---------------------------------------|
| 7-0 | | R | | 8-bit Digital Output of CMPIN voltage |

8.6.12 ADCSYSVBAT Register (I2C address = 2D/2Ch)

- VSYS: Full range: 2.88 V to 19.2 V, LSB: 64 mV
- VBAT: Full range: 2.88 V to 19.2 V, LSB: 64 mV

图 43. ADCSYSVBAT Register (I2C address = 2D/2Ch) (reset =)

| | | | | | | | |
|---|---|---|---|---|---|---|---|
| 7 | 6 | 5 | 4 | 3 | 2 | 1 | 0 |
| R | R | R | R | R | R | R | R |
| 7 | 6 | 5 | 4 | 3 | 2 | 1 | 0 |
| R | R | R | R | R | R | R | R |

LEGEND: R/W = Read/Write; R = Read only; -n = value after reset

表 45. ADCSYSVBAT Register (I2C address = 2Dh) Field Descriptions

| BIT | FIELD | TYPE | RESET | DESCRIPTION |
|-----|-------|------|-------|--|
| 7-0 | | R | | 8-bit Digital Output of System Voltage |

表 46. ADCSYSVBAT Register (I2C address = 2Ch) Field Descriptions

| BIT | FIELD | TYPE | RESET | DESCRIPTION |
|-----|-------|------|-------|---|
| 7-0 | | R | | 8-bit Digital Output of Battery Voltage |

8.6.13 ID Registers

8.6.13.1 ManufactureID Register (I2C address = 2Eh) [reset = 0040h]

图 44. ManufactureID Register (I2C address = 2Eh) [reset = 0040h]

| |
|----------------|
| 7-0 |
| MANUFACTURE_ID |
| R |

LEGEND: R/W = Read/Write; R = Read only; -n = value after reset

表 47. ManufactureID Register Field Descriptions

| I2C 2Eh | FIELD | TYPE | RESET | DESCRIPTION (READ ONLY) |
|------------|----------------|------|-------|-------------------------|
| 7-0 | MANUFACTURE_ID | R | | 40h |

8.6.13.2 Device ID (DeviceAddress) Register (I2C address = 2Fh) [reset = 0h]

图 45. Device ID (DeviceAddress) Register (I2C address = 2Fh) [reset = 0h]

| |
|-----------|
| 7-0 |
| DEVICE_ID |
| R |

LEGEND: R/W = Read/Write; R = Read only; -n = value after reset

表 48. Device ID (DeviceAddress) Register Field Descriptions

| I2C 2Fh | FIELD | TYPE | RESET | DESCRIPTION (READ ONLY) |
|------------|-----------|------|-------|-------------------------|
| 7-0 | DEVICE_ID | R | 0b | I2C:78h |

9 Application and Implementation

注

Information in the following applications sections is not part of the TI component specification, and TI does not warrant its accuracy or completeness. TI's customers are responsible for determining suitability of components for their purposes. Customers should validate and test their design implementation to confirm system functionality.

9.1 Application Information

The bq2570xEVM-732 evaluation module (EVM) is a complete charger module for evaluating the bq25703A. The application curves were taken using the bq2570xEVM-732. Refer to the EVM user's guide ([SLUUBG6](#)) for EVM information.

9.2 Typical Application

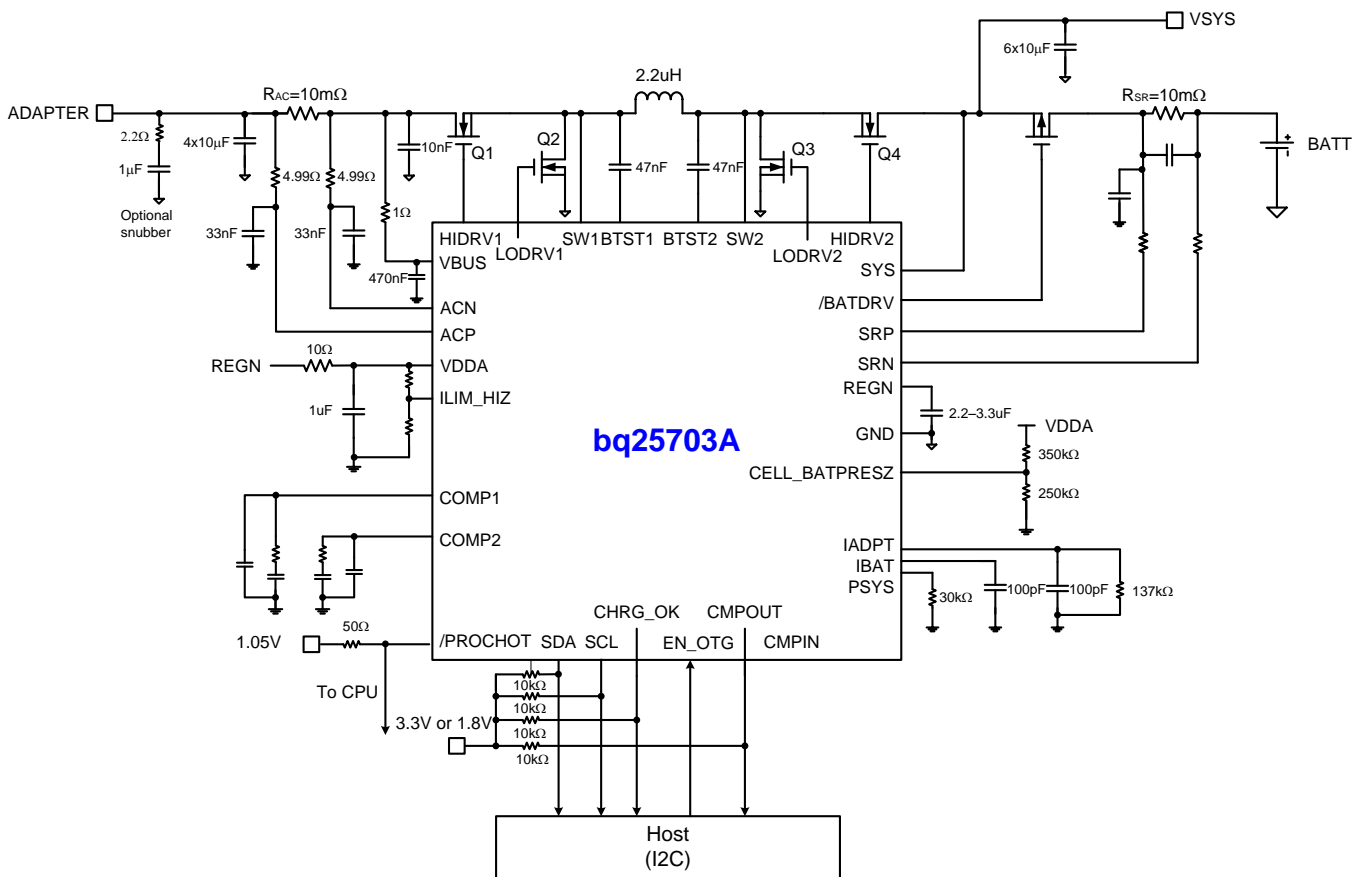

Copyright © 2017, Texas Instruments Incorporated

图 46. Application Diagram

9.2.1 Design Requirements

| DESIGN PARAMETER | EXAMPLE VALUE |
|---------------------------------------|--------------------------------|
| Input Voltage ⁽¹⁾ | 3.5 V < Adapter Voltage < 24 V |
| Input Current Limit ⁽¹⁾ | 3.2 A for 65 W adapter |
| Battery Charge Voltage ⁽²⁾ | 8400 mV for 2s battery |

(1) Refer to adapter specification for settings for Input Voltage and Input Current Limit.

(2) Refer to battery specification for settings.

Typical Application (接下页)

| DESIGN PARAMETER | EXAMPLE VALUE |
|---------------------------------------|------------------------|
| Battery Charge Current ⁽²⁾ | 3072 mA for 2s battery |
| Minimum System Voltage ⁽²⁾ | 6144 mV for 2s battery |

9.2.2 Detailed Design Procedure

The parameters are configurable using the evaluation software. The simplified application circuit (see 图 46, as the application diagram) shows the minimum component requirements. Inductor, capacitor, and MOSFET selection are explained in the rest of this section. Refer to the EVM user's guide (SLUUBG6) for the complete application schematic.

9.2.2.1 ACP-ACN Input Filter

The bq25703A has average current mode control. The input current sensing through ACP/ACN is critical to recover inductor current ripple. Parasitic inductance on board will generate high frequency ringing on ACP-ACN which overwhelms converter sensed inductor current information, so it is difficult to manage parasitic inductance created based on different PCB layout. Bigger parasitic inductance will generate bigger sense current ringing which will cause the average current control loop to go into oscillation.

For real system board condition, we suggest to use below circuit design to get best result and filter noise induced from different PCB parasitic factor. With time constant of filter from 47 nsec to 200 nsec, the filtering on ringing is effective and in the meantime, the delay of on the sensed signal is small and therefore poses no concern for average current mode control.

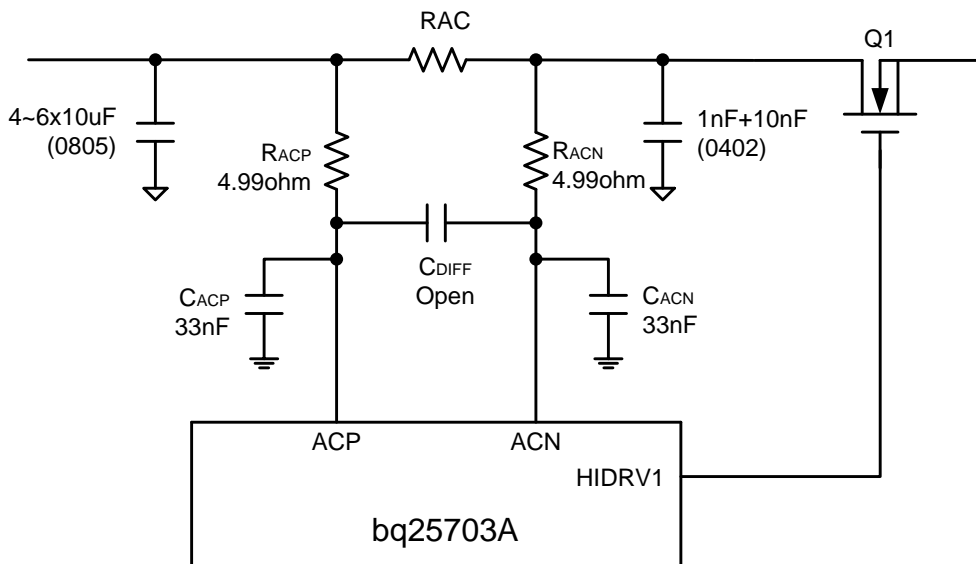

Copyright © 2017, Texas Instruments Incorporated

图 47. ACN-ACP Input Filter

9.2.2.2 Inductor Selection

The bq25703A has two selectable fixed switching frequency. Higher switching frequency allows the use of smaller inductor and capacitor values. Inductor saturation current should be higher than the charging current (I_{CHG}) plus half the ripple current (I_{RIPPLE}):

$$I_{SAT} \geq I_{CHG} + (1/2) I_{RIPPLE} \quad (3)$$

The inductor ripple current in buck operation depends on input voltage (V_{IN}), duty cycle ($D_{BUCK} = V_{OUT}/V_{IN}$), switching frequency (f_s) and inductance (L):

$$I_{RIPPLE_BUCK} = \frac{V_{IN} \times D \times (1 - D)}{f_s \times L} \quad (4)$$

During boost operation, the duty cycle is:

$$D_{\text{BOOST}} = 1 - (V_{\text{IN}}/V_{\text{BAT}})$$

and the ripple current is:

$$I_{\text{RIPPLE_BOOST}} = (V_{\text{IN}} \times D_{\text{BOOST}}) / (f_{\text{S}} \times L)$$

The maximum inductor ripple current happens with $D = 0.5$ or close to 0.5. For example, the battery charging voltage range is from 9 V to 12.6 V for 3-cell battery pack. For 20-V adapter voltage, 10-V battery voltage gives the maximum inductor ripple current. Another example is 4-cell battery, the battery voltage range is from 12 V to 16.8 V, and 12-V battery voltage gives the maximum inductor ripple current.

Usually inductor ripple is designed in the range of (20 – 40%) maximum charging current as a trade-off between inductor size and efficiency for a practical design.

9.2.2.3 Input Capacitor

Bulk input capacitors should be located in front of input current sensing resistor. Do not recommend to put bulk input capacitors between input sensing resistor and switching MOSFET. Input capacitor should have enough ripple current rating to absorb input switching ripple current. The worst case RMS ripple current is half of the charging current when duty cycle is 0.5 in buck mode. If the converter does not operate at 50% duty cycle, then the worst case capacitor RMS current occurs where the duty cycle is closest to 50% and can be estimated by [公式 5](#):

$$I_{\text{CIN}} = I_{\text{CHG}} \times \sqrt{D \times (1 - D)} \quad (5)$$

Low ESR ceramic capacitor such as X7R or X5R is preferred for input decoupling capacitor and should be placed to the drain of the high side MOSFET and source of the low side MOSFET as close as possible. Voltage rating of the capacitor must be higher than normal input voltage level. 25 V rating or higher capacitor is preferred for 19 V - 20 V input voltage. Minimum 10- μF effective capacitance (7 pcs of 10- μF 0805 size capacitor) is suggested for 45 W-65 W adapter.

Ceramic capacitors show a dc-bias effect. This effect reduces the effective capacitance when a dc-bias voltage is applied across a ceramic capacitor, as on the input capacitor of a charger. The effect may lead to a significant capacitance drop, especially for high input voltages and small capacitor packages. See the manufacturer's datasheet about the performance with a dc bias voltage applied. It may be necessary to choose a higher voltage rating or nominal capacitance value in order to get the required value at the operating point.

9.2.2.4 Output Capacitor

Output capacitor also should have enough ripple current rating to absorb output switching ripple current. In buck mode the output capacitor RMS current is given:

To get good loop stability, the resonant frequency of the output inductor and output capacitor should be designed between 10 kHz and 20 kHz. The preferred ceramic capacitor is 25-V X7R or X5R for output capacitor. Minimum 10- μF effective capacitance (7 pcs of 10- μF 0805 size capacitor) is suggested to be placed by the inductor, and 50- μF effective distributed capacitance on V_{SYS} output. Place the capacitors after Q4 drain. Place minimum 10 μF after the charge current sense resistor for best stability.

Ceramic capacitors show a dc-bias effect. This effect reduces the effective capacitance when a dc-bias voltage is applied across a ceramic capacitor, as on the output capacitor of a charger. The effect may lead to a significant capacitance drop, especially for high output voltages and small capacitor packages. See the manufacturer's data sheet about the performance with a dc bias voltage applied. It may be necessary to choose a higher voltage rating or nominal capacitance value in order to get the required value at the operating point.

9.2.2.5 Power MOSFETs Selection

Four external N-channel MOSFETs are used for a synchronous switching battery charger. The gate drivers are internally integrated into the IC with 6 V of gate drive voltage. 30 V or higher voltage rating MOSFETs are preferred for 19 V - 20 V input voltage.

Figure-of-merit (FOM) is usually used for selecting proper MOSFET based on a tradeoff between the conduction loss and switching loss. For the top side MOSFET, FOM is defined as the product of a MOSFET's on-resistance, $R_{\text{DS(ON)}}$, and the gate-to-drain charge, Q_{GD} . For the bottom side MOSFET, FOM is defined as the product of the MOSFET's on-resistance, $R_{\text{DS(ON)}}$, and the total gate charge, Q_{G} .

$$\text{FOM}_{\text{top}} = R_{\text{DS(on)}} \times Q_{\text{GD}}; \text{FOM}_{\text{bottom}} = R_{\text{DS(on)}} \times Q_{\text{G}} \quad (6)$$

The lower the FOM value, the lower the total power loss. Usually lower $R_{DS(ON)}$ has higher cost with the same package size.

The top-side MOSFET loss includes conduction loss and switching loss. It is a function of duty cycle ($D=V_{OUT}/V_{IN}$), charging current (I_{CHG}), MOSFET's on-resistance ($R_{DS(ON)}$), input voltage (V_{IN}), switching frequency (f_s), turn on time (t_{on}) and turn off time (t_{off}):

$$P_{top} = D \times I_{CHG}^2 \times R_{DS(on)} + \frac{1}{2} \times V_{IN} \times I_{CHG} \times (t_{on} + t_{off}) \times f_s \tag{7}$$

The first item represents the conduction loss. Usually MOSFET $R_{DS(ON)}$ increases by 50% with 100°C junction temperature rise. The second term represents the switching loss. The MOSFET turn-on and turn-off times are given by:

$$t_{on} = \frac{Q_{SW}}{I_{on}}, \quad t_{off} = \frac{Q_{SW}}{I_{off}} \tag{8}$$

where Q_{SW} is the switching charge, I_{on} is the turn-on gate driving current and I_{off} is the turn-off gate driving current. If the switching charge is not given in MOSFET datasheet, it can be estimated by gate-to-drain charge (Q_{GD}) and gate-to-source charge (Q_{GS}):

$$Q_{SW} = Q_{GD} + \frac{1}{2} \times Q_{GS} \tag{9}$$

Gate driving current can be estimated by REGN voltage (V_{REGN}), MOSFET plateau voltage (V_{plt}), total turn-on gate resistance (R_{on}) and turn-off gate resistance (R_{off}) of the gate driver:

$$I_{on} = \frac{V_{REGN} - V_{plt}}{R_{on}}, \quad I_{off} = \frac{V_{plt}}{R_{off}} \tag{10}$$

The conduction loss of the bottom-side MOSFET is calculated with the following equation when it operates in synchronous continuous conduction mode:

$$P_{bottom} = (1 - D) \times I_{CHG}^2 \times R_{DS(on)} \tag{11}$$

When charger operates in non-synchronous mode, the bottom-side MOSFET is off. As a result all the freewheeling current goes through the body-diode of the bottom-side MOSFET. The body diode power loss depends on its forward voltage drop (V_F), non-synchronous mode charging current (I_{NONSYN}), and duty cycle (D).

$$P_D = V_F \times I_{NONSYN} \times (1 - D) \tag{12}$$

The maximum charging current in non-synchronous mode can be up to 0.25 A for a 10-mΩ charging current sensing resistor or 0.5 A if battery voltage is below 2.5 V. The minimum duty cycle happens at lowest battery voltage. Choose the bottom-side MOSFET with either an internal Schottky or body diode capable of carrying the maximum non-synchronous mode charging current.

9.2.3 Application Curves

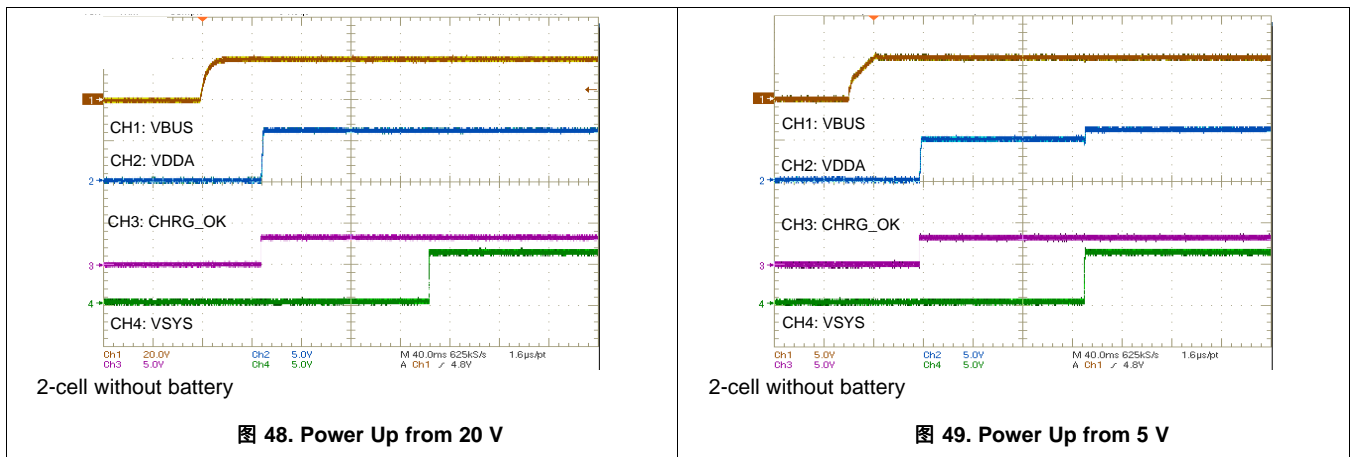

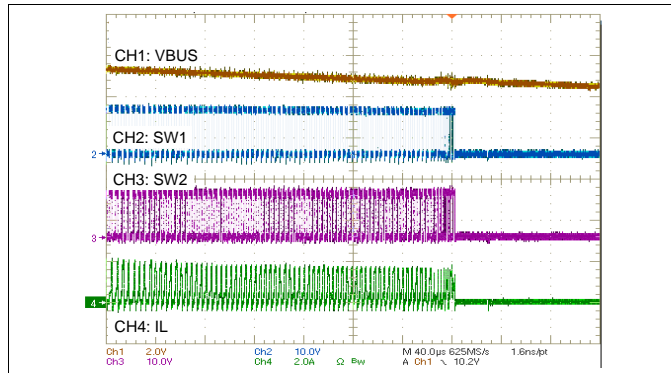

3-cell VBAT = 10 V

图 50. Power Off from 12 V

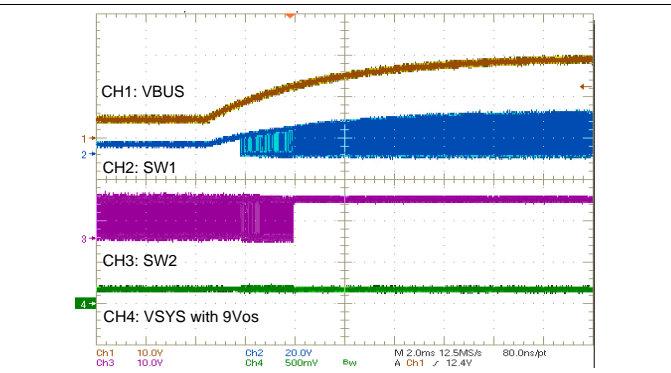

VBUS 5 V to 20 V

图 51. System Regulation

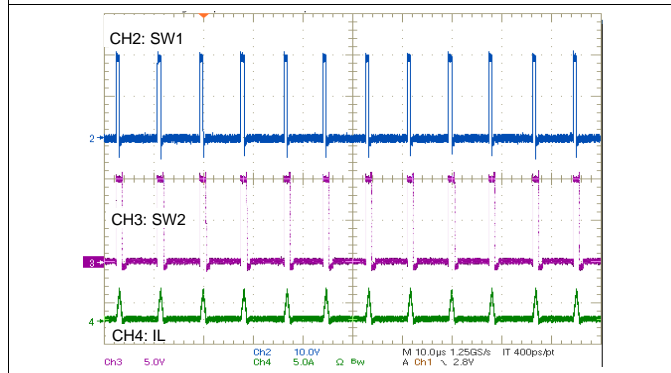

VBUS = 20 V, VSYS = 10 V, ISYS = 200 mA

图 52. PFM Operation



图 53. PWM Operation



VBUS = 5 V, VBAT = 10 V

图 54. Switching During Boost Mode

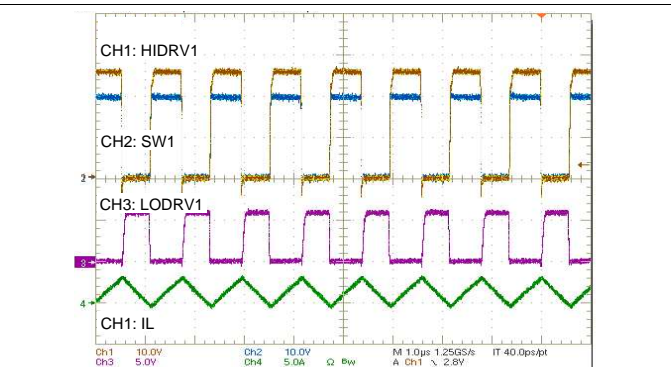
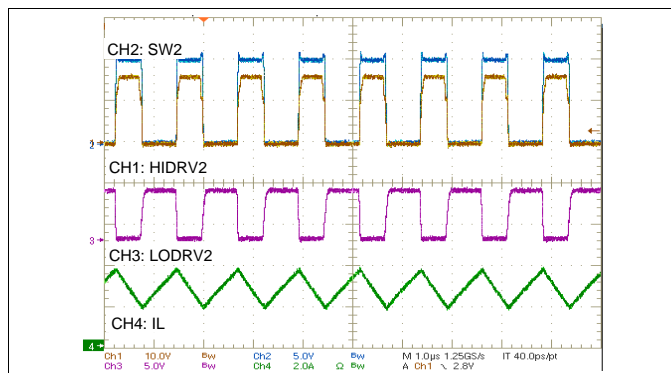
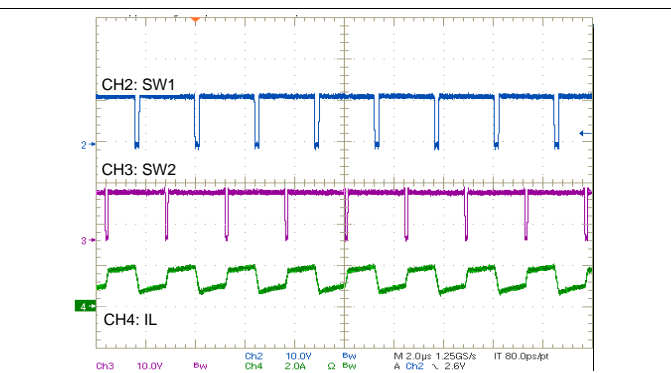

VBUS = 12 V, VBAT = 12 V

图 55. Switching During Buck Boost Mode

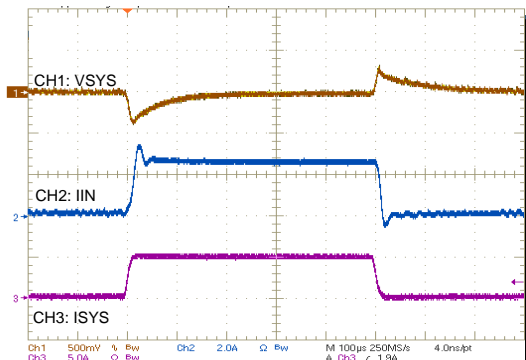

VBUS = 12 V/3.3 A, 3-cell, VSYS = 9 V, Without battery

图 56. System Regulation in Buck Mode

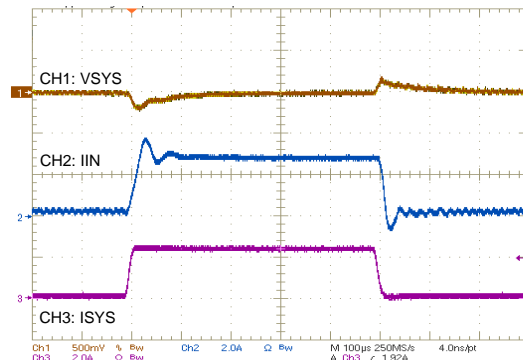

VBUS = 9 V/3.3 A, 3-cell, VSYS = 9 V, Without battery

图 57. System Regulation in Buck Boost Mode

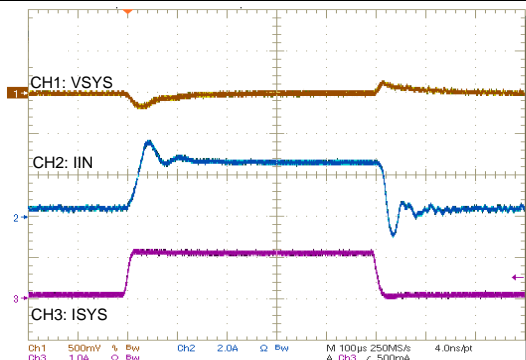

VBUS = 5 V/3.3 A, 3-cell, VSYS = 9 V, Without battery

图 58. System Regulation in Boost Mode

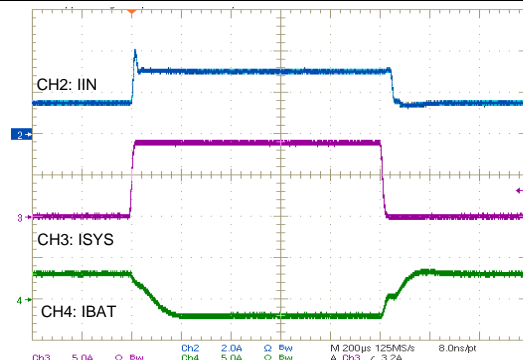

VBUS = 20 V/3.3 V, VBAT = 7.5 V

图 59. Input Current Regulation in Buck Mode

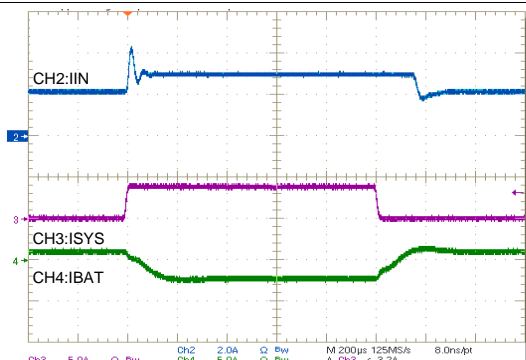

VBUS = 5 V/3.3 V, VBAT = 7.5 V

图 60. Input Current in Boost Mode

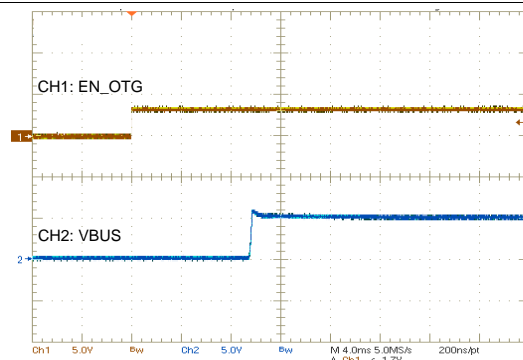

VBUS = 5 V

图 61. OTG Power Up from 8 V Battery

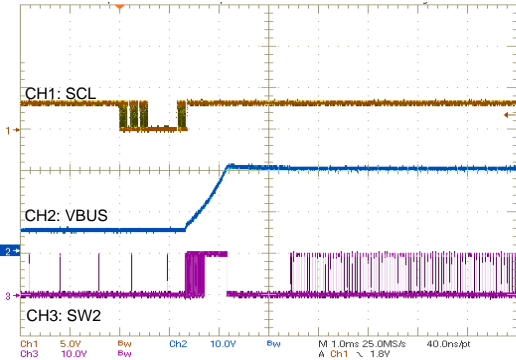

VBAT = 10 V, VBUS 5 V to 20 V, IOTG = 500 mA

图 62. OTG Voltage Ramp Up



图 63. OTG Power Off



VBAT = 10 V, VBUS = 20 V

图 64. OTG Load Transient

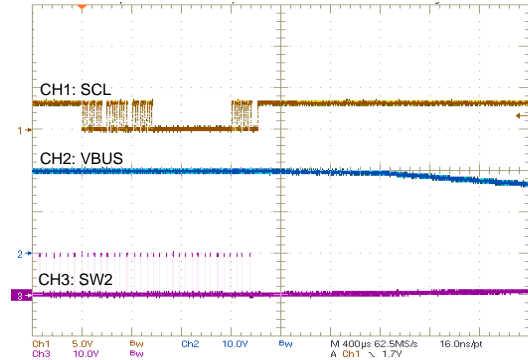
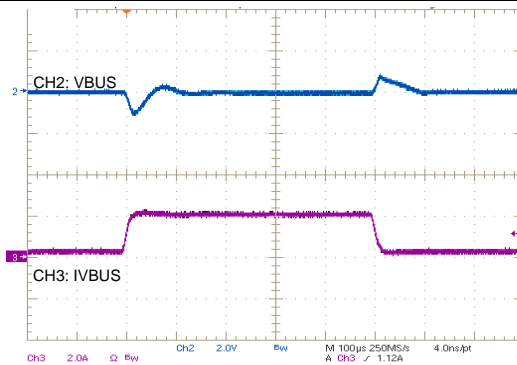
10 Power Supply Recommendations

The valid adapter range is from 3.5 V ($V_{V_{BUS_CONVEN}}$) to 24 V (ACOV) with at least 500-mA current rating. When CHRG_OK goes HIGH, the system is powered from adapter through the charger. When adapter is removed, the system is connected to battery through BATFET. Typically the battery depletion threshold should be greater than the minimum system voltage so that the battery capacity can be fully utilized for maximum battery life.

11 Layout

11.1 Layout Guidelines

The switching node rise and fall times should be minimized for minimum switching loss. Proper layout of the components to minimize high frequency current path loop (see [Layout Example](#) section) is important to prevent electrical and magnetic field radiation and high frequency resonant problems. Here is a PCB layout priority list for proper layout. Layout PCB according to this specific order is essential.

1. Place the input capacitor as close as possible to the supply of the switching MOSFET and ground connections. Use a short copper trace connection. These parts must be placed on the same layer of PCB using vias to make this connection.
2. The device must be placed close to the gate pins of the switching MOSFET. Keep the gate drive signal traces short for a clean MOSFET drive. The device can be placed on the other side of the PCB of switching MOSFETs.
3. Place an inductor input pin as close as possible to the output pin of the switching MOSFET. Minimize the copper area of this trace to lower electrical and magnetic field radiation but make the trace wide enough to carry the charging current. Do not use multiple layers in parallel for this connection. Minimize parasitic capacitance from this area to any other trace or plane.
4. The charging current sensing resistor should be placed right next to the inductor output. Route the sense leads connected across the sensing resistor back to the device in same layer, close to each other (minimize loop area) and do not route the sense leads through a high-current path (see [图 66](#) for Kelvin connection for best current accuracy). Place a decoupling capacitor on these traces next to the device.
5. Place an output capacitor next to the sensing resistor output and ground.
6. Output capacitor ground connections must be tied to the same copper that connects to the input capacitor ground before connecting to system ground.
7. Use a single ground connection to tie the charger power ground to the charger analog ground. Just beneath the device, use analog ground copper pour but avoid power pins to reduce inductive and capacitive noise coupling.
8. Route analog ground separately from power ground. Connect analog ground and connect power ground separately. Connect analog ground and power ground together using power pad as the single ground connection point. Or using a 0-Ω resistor to tie analog ground to power ground (power pad should tie to analog ground in this case if possible).
9. Decoupling capacitors must be placed next to the device pins. Make trace connection as short as possible.
10. It is critical that the exposed power pad on the backside of the device package be soldered to the PCB ground.
11. The via size and number should be enough for a given current path. See the EVM design ([SLUUBG6](#)) for the recommended component placement with trace and via locations. For WQFN information, see [SLUA271](#).

11.2 Layout Example

11.2.1 Layout Consideration of Current Path



图 65. High Frequency Current Path

Layout Example (接下页)

11.2.2 Layout Consideration of Short Circuit Protection

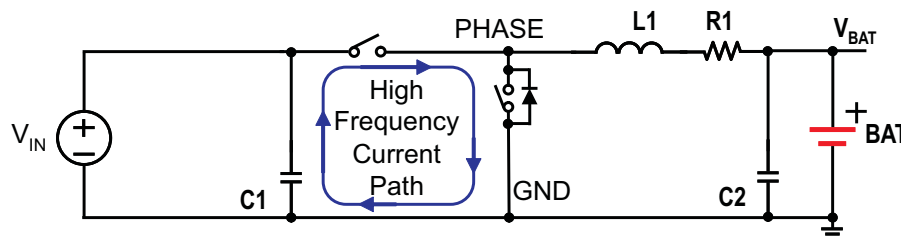

图 66. Sensing Resistor PCB Layout

12 器件和文档支持

12.1 器件支持

12.1.1 第三方产品免责声明

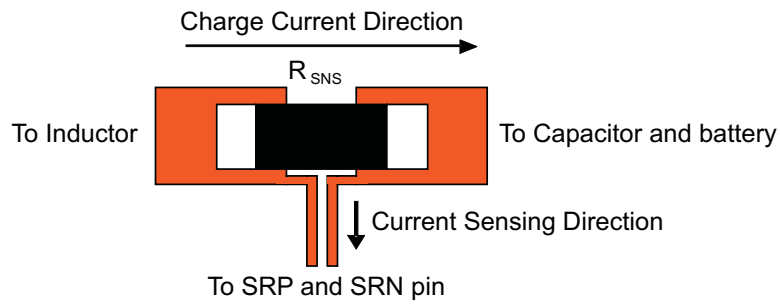
TI 发布的与第三方产品或服务有关的信息，不能构成与此类产品或服务或保修的适用性有关的认可，不能构成此类产品或服务单独或与任何 TI 产品或服务一起的表示或认可。

12.2 文档支持

12.2.1 相关文档

请参阅如下相关文档：

- 半导体和集成电路封装热指标 应用报告 [SPRA953](#)
- bq2570x 评估模块 用户指南 [SLUUBG6](#)
- QFN/SON PCB 连接 应用报告 [SLUA271](#)

12.3 接收文档更新通知

要接收文档更新通知，请导航至 TI.com.cn 上的器件产品文件夹。单击右上角的 [通知我](#) 进行注册，即可每周接收产品信息更改摘要。有关更改的详细信息，请查看任何已修订文档中包含的修订历史记录。

12.4 社区资源

下列链接提供到 TI 社区资源的连接。链接的内容由各个分销商“按照原样”提供。这些内容并不构成 TI 技术规范，并且不一定反映 TI 的观点；请参阅 TI 的 [《使用条款》](#)。

TI E2E™ 在线社区 [TI 的工程师对工程师 \(E2E\) 社区](#)。此社区的创建目的在于促进工程师之间的协作。在 e2e.ti.com 中，您可以咨询问题、分享知识、拓展思路并与同行工程师一道帮助解决问题。

设计支持 [TI 参考设计支持](#) 可帮助您快速查找有帮助的 E2E 论坛、设计支持工具以及技术支持的联系信息。

12.5 商标

E2E is a trademark of Texas Instruments.
All other trademarks are the property of their respective owners.

12.6 静电放电警告



这些装置包含有限的内置 ESD 保护。存储或装卸时，应将导线一起截短或将装置放置于导电泡棉中，以防止 MOS 门极遭受静电损伤。

12.7 术语表

[SLYZ022](#) — *TI* 术语表。

这份术语表列出并解释术语、缩写和定义。

13 机械、封装和可订购信息

以下页面包含机械、封装和可订购信息。这些信息是指定器件的最新可用数据。数据如有变更，恕不另行通知，且不会对此文档进行修订。如需获取此数据表的浏览器版本，请查阅左侧的导航栏。

13.1 Package Option Addendum

13.1.1 Packaging Information

| Orderable Device | Status ⁽¹⁾ | Package Type | Package Drawing | Pins | Package Qty | Eco Plan ⁽²⁾ | Lead/Ball Finish ⁽³⁾ | MSL Peak Temp ⁽⁴⁾ | Op Temp (°C) | Device Marking ⁽⁵⁾⁽⁶⁾ |
|------------------|-----------------------|--------------|-----------------|------|-------------|-------------------------|---------------------------------|------------------------------|--------------|----------------------------------|
| bq25703ARSNR | PREVIEW | WQFN | RSN | 32 | 3000 | Green (RoHS & no Sb/Br) | CU NIPDAU | Level-2-260C-1 YEAR | -40 to 85 | bq25703A |
| bq25703ARSNT | PREVIEW | WQFN | RSN | 32 | 250 | Green (RoHS & no Sb/Br) | CU NIPDAU | Level-2-260C-1 YEAR | -40 to 85 | bq25703A |

- (1) The marketing status values are defined as follows:
ACTIVE: Product device recommended for new designs.
LIFEBUY: TI has announced that the device will be discontinued, and a lifetime-buy period is in effect.
NRND: Not recommended for new designs. Device is in production to support existing customers, but TI does not recommend using this part in a new design.
PRE_PROD Unannounced device, not in production, not available for mass market, nor on the web, samples not available.
PREVIEW: Device has been announced but is not in production. Samples may or may not be available.
OBSOLETE: TI has discontinued the production of the device.
- (2) Eco Plan - The planned eco-friendly classification: Pb-Free (RoHS), Pb-Free (RoHS Exempt), or Green (RoHS & no Sb/Br) - please check <http://www.ti.com/productcontent> for the latest availability information and additional product content details.
TBD: The Pb-Free/Green conversion plan has not been defined.
Pb-Free (RoHS): TI's terms "Lead-Free" or "Pb-Free" mean semiconductor products that are compatible with the current RoHS requirements for all 6 substances, including the requirement that lead not exceed 0.1% by weight in homogeneous materials. Where designed to be soldered at high temperatures, TI Pb-Free products are suitable for use in specified lead-free processes.
Pb-Free (RoHS Exempt): This component has a RoHS exemption for either 1) lead-based flip-chip solder bumps used between the die and package, or 2) lead-based die adhesive used between the die and leadframe. The component is otherwise considered Pb-Free (RoHS compatible) as defined above.
Green (RoHS & no Sb/Br): TI defines "Green" to mean Pb-Free (RoHS compatible), and free of Bromine (Br) and Antimony (Sb) based flame retardants (Br or Sb do not exceed 0.1% by weight in homogeneous material)
- (3) Lead/Ball Finish - Orderable Devices may have multiple material finish options. Finish options are separated by a vertical ruled line. Lead/Ball Finish values may wrap to two lines if the finish value exceeds the maximum column width.
- (4) MSL, Peak Temp. -- The Moisture Sensitivity Level rating according to the JEDEC industry standard classifications, and peak solder temperature.
- (5) There may be additional marking, which relates to the logo, the lot trace code information, or the environmental category on the device
- (6) Multiple Device markings will be inside parentheses. Only on Device Marking contained in parentheses and separated by a "-" will appear on a device. If a line is indented then it is a continuation of the previous line and the two combined represent the entire Device Marking for that device.

Important Information and Disclaimer: The information provided on this page represents TI's knowledge and belief as of the date that it is provided. TI bases its knowledge and belief on information provided by third parties, and makes no representation or warranty as to the accuracy of such information. Efforts are underway to better integrate information from third parties. TI has taken and continues to take reasonable steps to provide representative and accurate information but may not have conducted destructive testing or chemical analysis on incoming materials and chemicals. TI and TI suppliers consider certain information to be proprietary, and thus CAS numbers and other limited information may not be available for release.

In no event shall TI's liability arising out of such information exceed the total purchase price of the TI part(s) at issue in this document sold by TI to Customer on an annual basis.

13.1.2 Tape and Reel Information

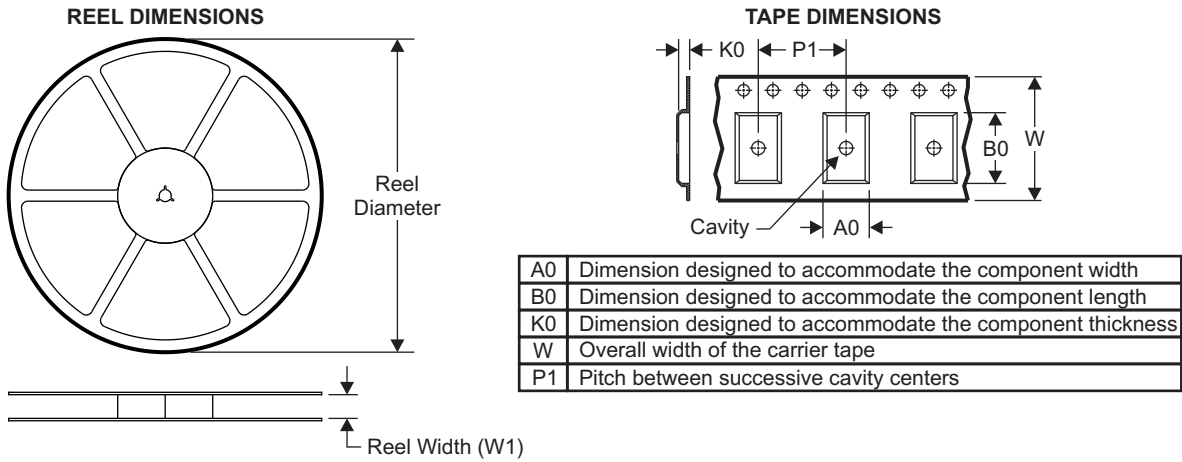

QUADRANT ASSIGNMENTS FOR PIN 1 ORIENTATION IN TAPE

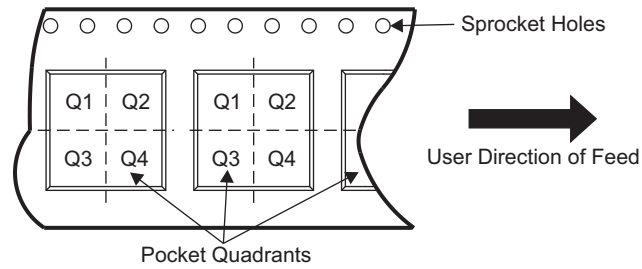

| Device | Package Type | Package Drawing | Pins | SPQ | Reel Diameter (mm) | Reel Width W1 (mm) | A0 (mm) | B0 (mm) | K0 (mm) | P1 (mm) | W (mm) | Pin1 Quadrant |
|--------------|--------------|-----------------|------|------|--------------------|--------------------|---------|---------|---------|---------|--------|---------------|
| bq25703ARSNR | WQFN | RSN | 32 | 3000 | 330.0 | 12.4 | 4.25 | 4.25 | 1.15 | 8.0 | 12.0 | Q2 |
| bq25703ARSNT | WQFN | RSN | 32 | 250 | 330.0 | 12.4 | 4.25 | 4.25 | 1.15 | 8.0 | 12.0 | Q2 |

bq25703A

ZHCSGD8A – MAY 2017 – REVISED MAY 2018

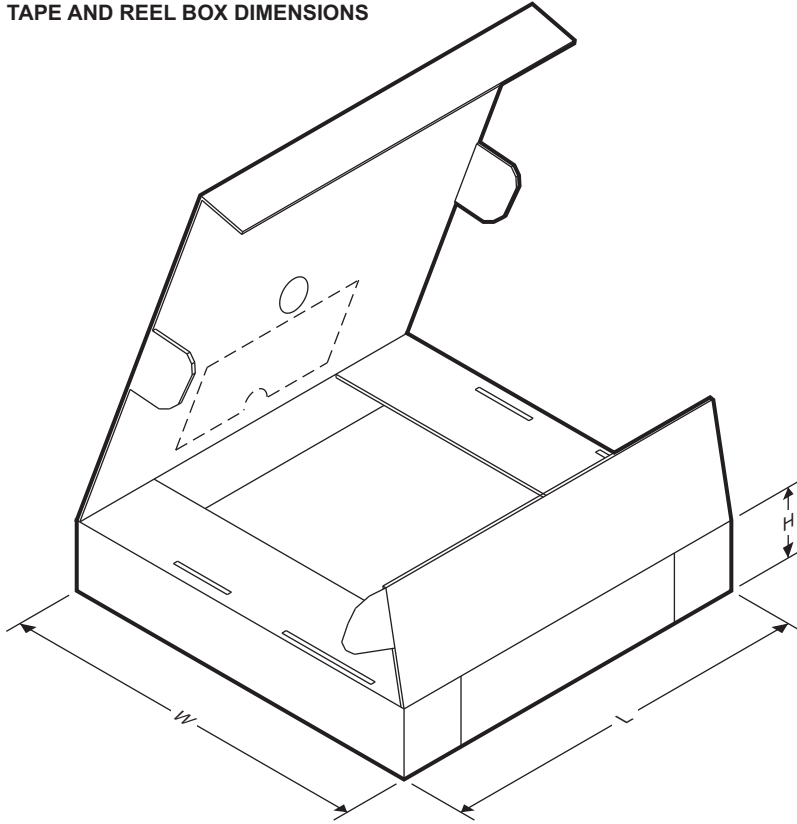
www.ti.com.cn
TAPE AND REEL BOX DIMENSIONS

| Device | Package Type | Package Drawing | Pins | SPQ | Length (mm) | Width (mm) | Height (mm) |
|--------------|--------------|-----------------|------|------|-------------|------------|-------------|
| bq25703ARSNR | WQFN | RSN | 32 | 3000 | 367.0 | 367.0 | 35.0 |
| bq25703ARSNT | WQFN | RSN | 32 | 250 | 210.0 | 185.0 | 35.0 |

MECHANICAL DATA

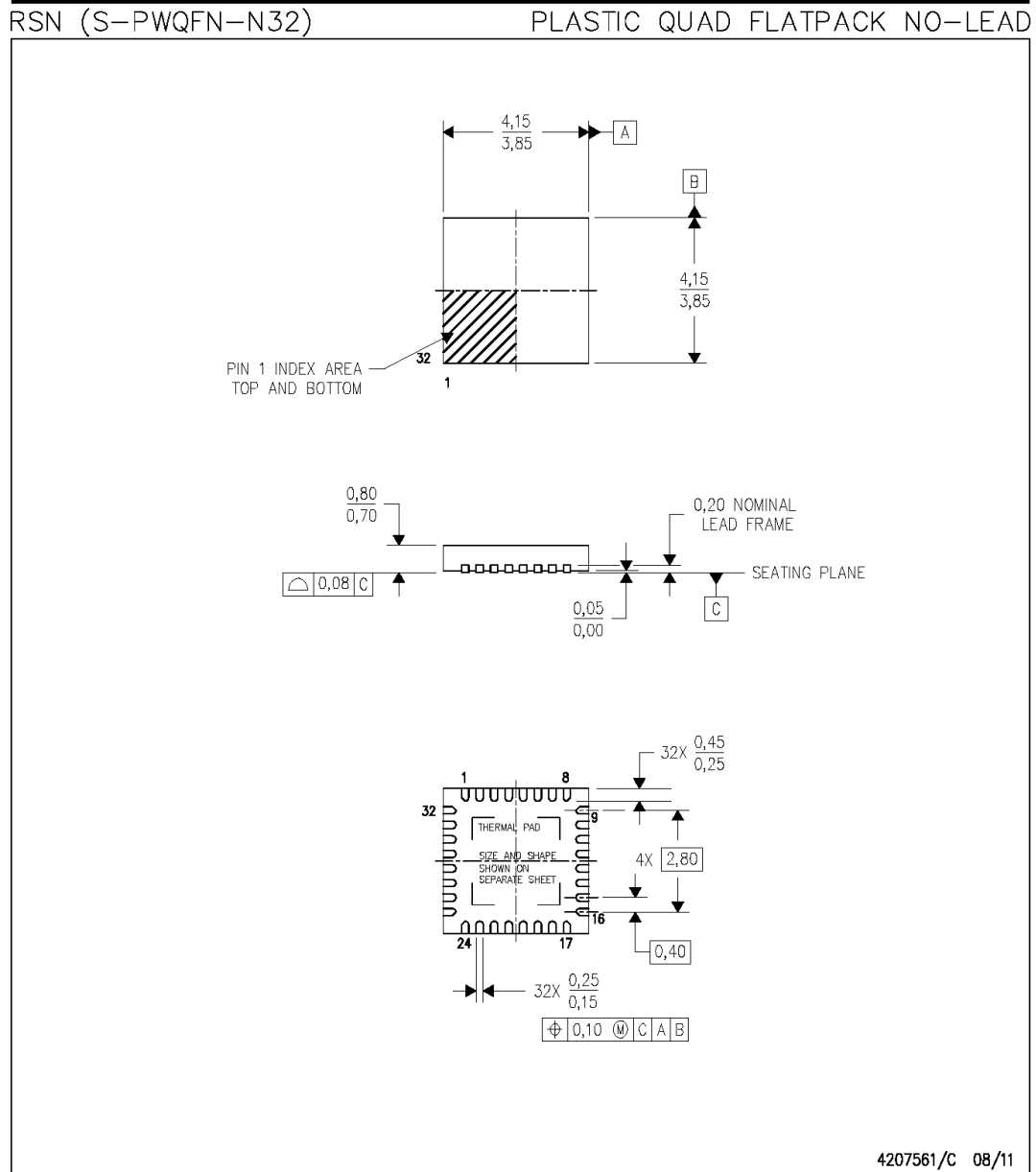

- NOTES:
- A. All linear dimensions are in millimeters. Dimensioning and tolerancing per ASME Y14.5M-1994.
 - B. This drawing is subject to change without notice.
 - C. QFN (Quad Flatpack No-Lead) Package configuration.
 - D. The package thermal pad must be soldered to the board for thermal and mechanical performance.
 - E. See the additional figure in the Product Data Sheet for details regarding the exposed thermal pad features and dimensions.

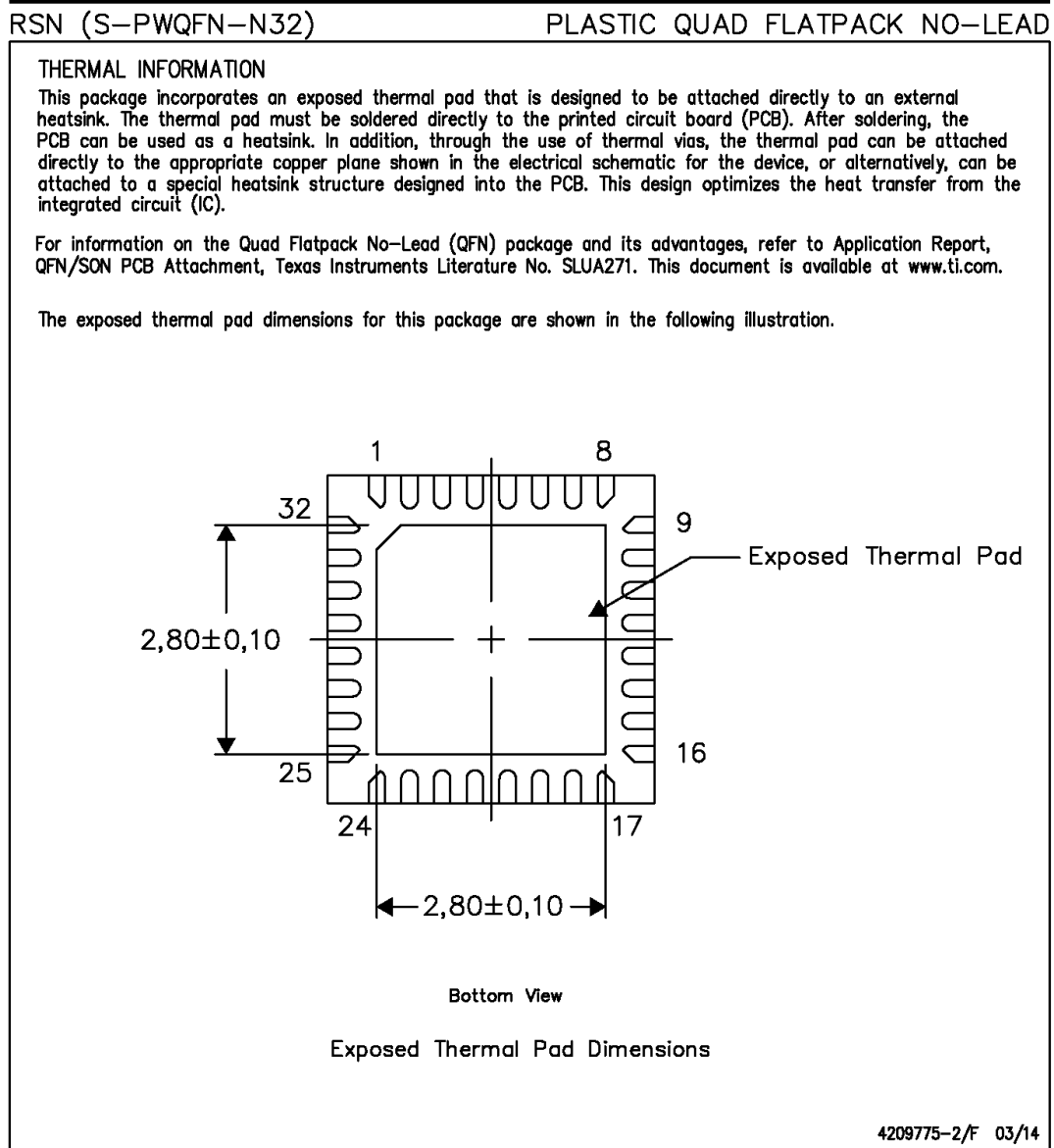
THERMAL PAD MECHANICAL DATA

NOTE: All linear dimensions are in millimeters

LAND PATTERN DATA

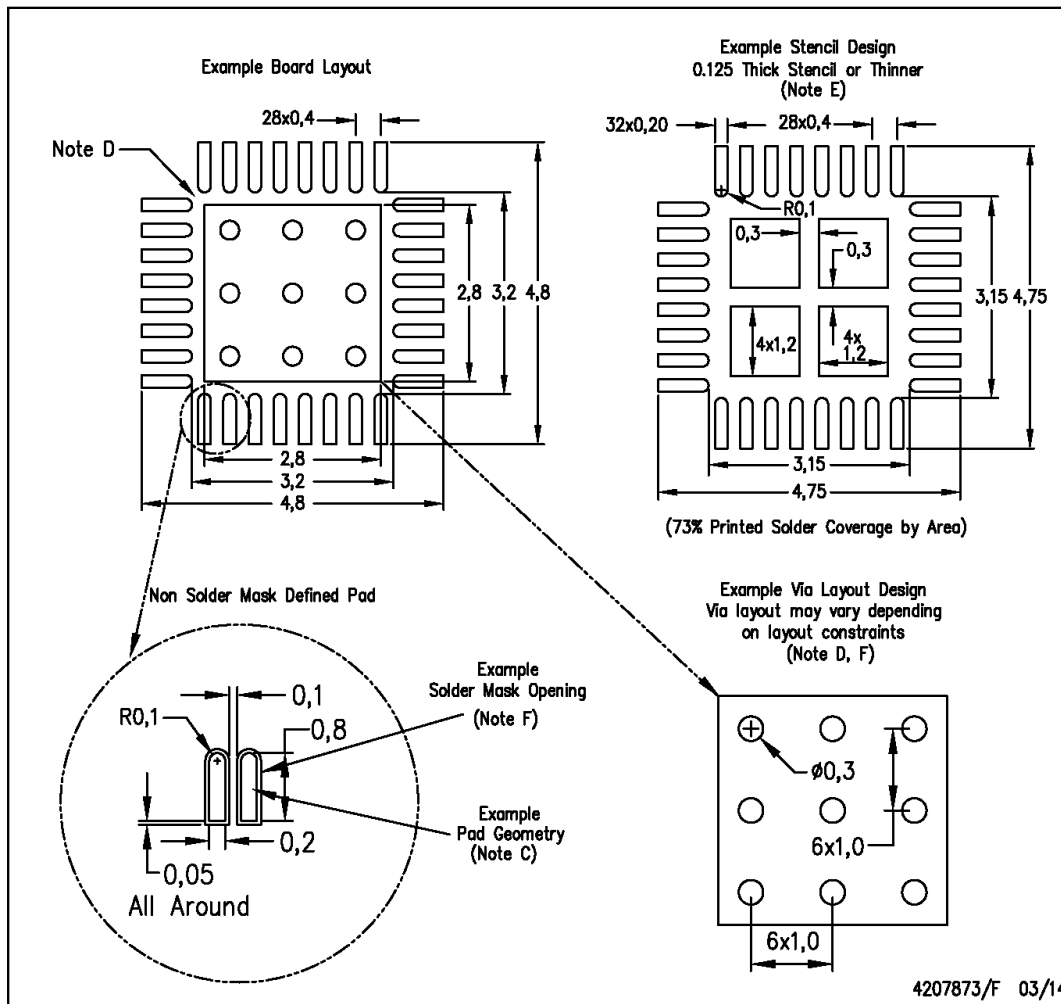

RSN (S–PWQFN–N32)

PLASTIC QUAD FLATPACK NO–LEAD



- NOTES:
- All linear dimensions are in millimeters.
 - This drawing is subject to change without notice.
 - Publication IPC–7351 is recommended for alternate designs.
 - This package is designed to be soldered to a thermal pad on the board. Refer to Application Note, Quad Flat–Pack Packages, Texas Instruments Literature No. SLUA271, and also the Product Data Sheets for specific thermal information, via requirements, and recommended board layout. These documents are available at www.ti.com <<http://www.ti.com>>.
 - Laser cutting apertures with trapezoidal walls and also rounding corners will offer better paste release. Customers should contact their board assembly site for stencil design recommendations. Refer to IPC 7525 for stencil design considerations.
 - Customers should contact their board fabrication site for recommended solder mask tolerances and via tenting recommendations for vias placed in the thermal pad.

PACKAGING INFORMATION

| Orderable Device | Status (1) | Package Type | Package Drawing | Pins | Package Qty | Eco Plan (2) | Lead finish/ Ball material (6) | MSL Peak Temp (3) | Op Temp (°C) | Device Marking (4/5) | Samples |
|------------------|---------------|--------------|-----------------|------|-------------|-----------------|--------------------------------------|----------------------|--------------|-------------------------|---|
| BQ25703ARSNR | ACTIVE | QFN | RSN | 32 | 3000 | RoHS & Green | NIPDAU | Level-1-260C-UNLIM | -40 to 85 | BQ 25703A |  |
| BQ25703ARSNT | ACTIVE | QFN | RSN | 32 | 250 | RoHS & Green | NIPDAU | Level-1-260C-UNLIM | -40 to 85 | BQ 25703A |  |

(1) The marketing status values are defined as follows:

ACTIVE: Product device recommended for new designs.

LIFEBUY: TI has announced that the device will be discontinued, and a lifetime-buy period is in effect.

NRND: Not recommended for new designs. Device is in production to support existing customers, but TI does not recommend using this part in a new design.

PREVIEW: Device has been announced but is not in production. Samples may or may not be available.

OBSOLETE: TI has discontinued the production of the device.

(2) **RoHS:** TI defines "RoHS" to mean semiconductor products that are compliant with the current EU RoHS requirements for all 10 RoHS substances, including the requirement that RoHS substance do not exceed 0.1% by weight in homogeneous materials. Where designed to be soldered at high temperatures, "RoHS" products are suitable for use in specified lead-free processes. TI may reference these types of products as "Pb-Free".

RoHS Exempt: TI defines "RoHS Exempt" to mean products that contain lead but are compliant with EU RoHS pursuant to a specific EU RoHS exemption.

Green: TI defines "Green" to mean the content of Chlorine (Cl) and Bromine (Br) based flame retardants meet JS709B low halogen requirements of <=1000ppm threshold. Antimony trioxide based flame retardants must also meet the <=1000ppm threshold requirement.

(3) MSL, Peak Temp. - The Moisture Sensitivity Level rating according to the JEDEC industry standard classifications, and peak solder temperature.

(4) There may be additional marking, which relates to the logo, the lot trace code information, or the environmental category on the device.

(5) Multiple Device Markings will be inside parentheses. Only one Device Marking contained in parentheses and separated by a "~" will appear on a device. If a line is indented then it is a continuation of the previous line and the two combined represent the entire Device Marking for that device.

(6) Lead finish/Ball material - Orderable Devices may have multiple material finish options. Finish options are separated by a vertical ruled line. Lead finish/Ball material values may wrap to two lines if the finish value exceeds the maximum column width.

Important Information and Disclaimer:The information provided on this page represents TI's knowledge and belief as of the date that it is provided. TI bases its knowledge and belief on information provided by third parties, and makes no representation or warranty as to the accuracy of such information. Efforts are underway to better integrate information from third parties. TI has taken and continues to take reasonable steps to provide representative and accurate information but may not have conducted destructive testing or chemical analysis on incoming materials and chemicals. TI and TI suppliers consider certain information to be proprietary, and thus CAS numbers and other limited information may not be available for release.

In no event shall TI's liability arising out of such information exceed the total purchase price of the TI part(s) at issue in this document sold by TI to Customer on an annual basis.

TAPE AND REEL INFORMATION



QUADRANT ASSIGNMENTS FOR PIN 1 ORIENTATION IN TAPE



*All dimensions are nominal

| Device | Package Type | Package Drawing | Pins | SPQ | Reel Diameter (mm) | Reel Width W1 (mm) | A0 (mm) | B0 (mm) | K0 (mm) | P1 (mm) | W (mm) | Pin1 Quadrant |
|--------------|--------------|-----------------|------|------|--------------------|--------------------|---------|---------|---------|---------|--------|---------------|
| BQ25703ARSNR | QFN | RSN | 32 | 3000 | 330.0 | 12.4 | 4.25 | 4.25 | 1.15 | 8.0 | 12.0 | Q2 |
| BQ25703ARSNT | QFN | RSN | 32 | 250 | 180.0 | 12.4 | 4.25 | 4.25 | 1.15 | 8.0 | 12.0 | Q2 |

TAPE AND REEL BOX DIMENSIONS

*All dimensions are nominal

| Device | Package Type | Package Drawing | Pins | SPQ | Length (mm) | Width (mm) | Height (mm) |
|--------------|--------------|-----------------|------|------|-------------|------------|-------------|
| BQ25703ARSNR | QFN | RSN | 32 | 3000 | 367.0 | 367.0 | 35.0 |
| BQ25703ARSNT | QFN | RSN | 32 | 250 | 210.0 | 185.0 | 35.0 |

RSN (S-PWQFN-N32)

PLASTIC QUAD FLATPACK NO-LEAD

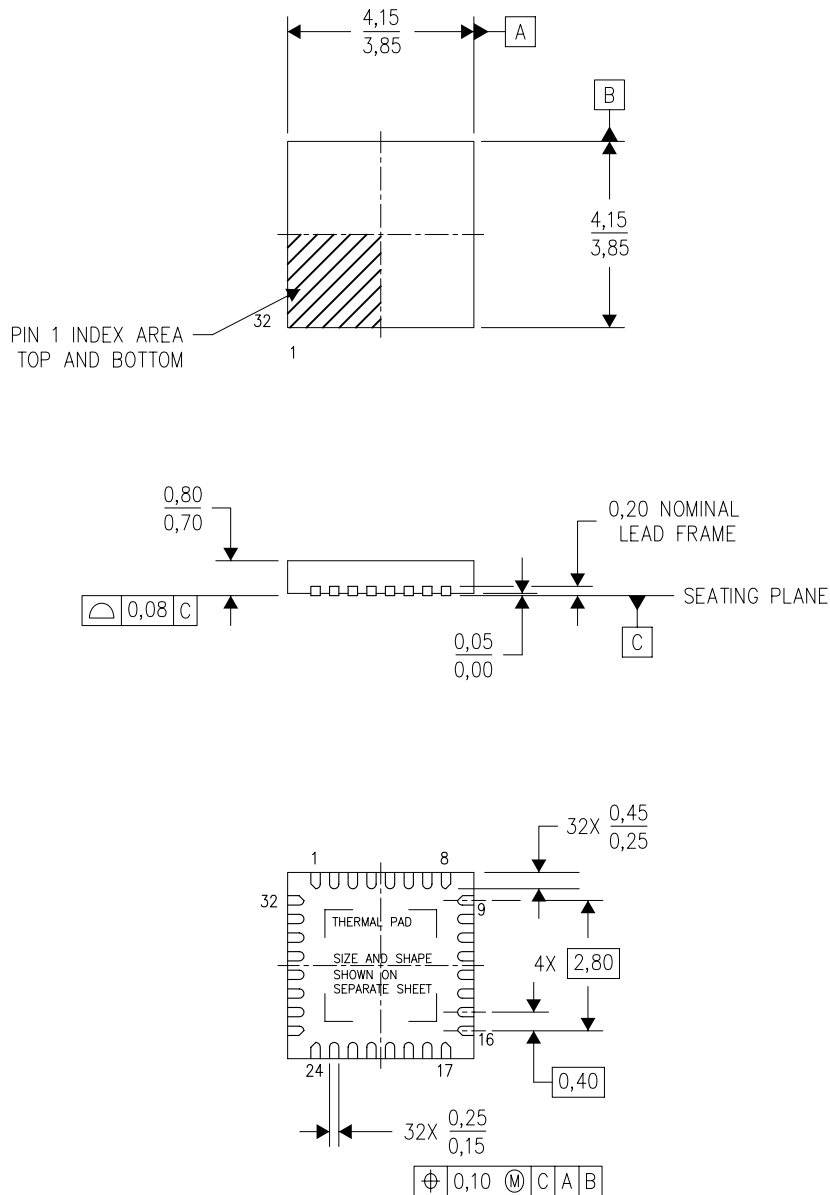

4207561/C 08/11

- NOTES:
- All linear dimensions are in millimeters. Dimensioning and tolerancing per ASME Y14.5M-1994.
 - This drawing is subject to change without notice.
 - QFN (Quad Flatpack No-Lead) Package configuration.
 - The package thermal pad must be soldered to the board for thermal and mechanical performance.
 - See the additional figure in the Product Data Sheet for details regarding the exposed thermal pad features and dimensions.

THERMAL PAD MECHANICAL DATA

RSN (S-PWQFN-N32)

PLASTIC QUAD FLATPACK NO-LEAD

THERMAL INFORMATION

This package incorporates an exposed thermal pad that is designed to be attached directly to an external heatsink. The thermal pad must be soldered directly to the printed circuit board (PCB). After soldering, the PCB can be used as a heatsink. In addition, through the use of thermal vias, the thermal pad can be attached directly to the appropriate copper plane shown in the electrical schematic for the device, or alternatively, can be attached to a special heatsink structure designed into the PCB. This design optimizes the heat transfer from the integrated circuit (IC).

For information on the Quad Flatpack No-Lead (QFN) package and its advantages, refer to Application Report, QFN/SON PCB Attachment, Texas Instruments Literature No. SLUA271. This document is available at www.ti.com.

The exposed thermal pad dimensions for this package are shown in the following illustration.

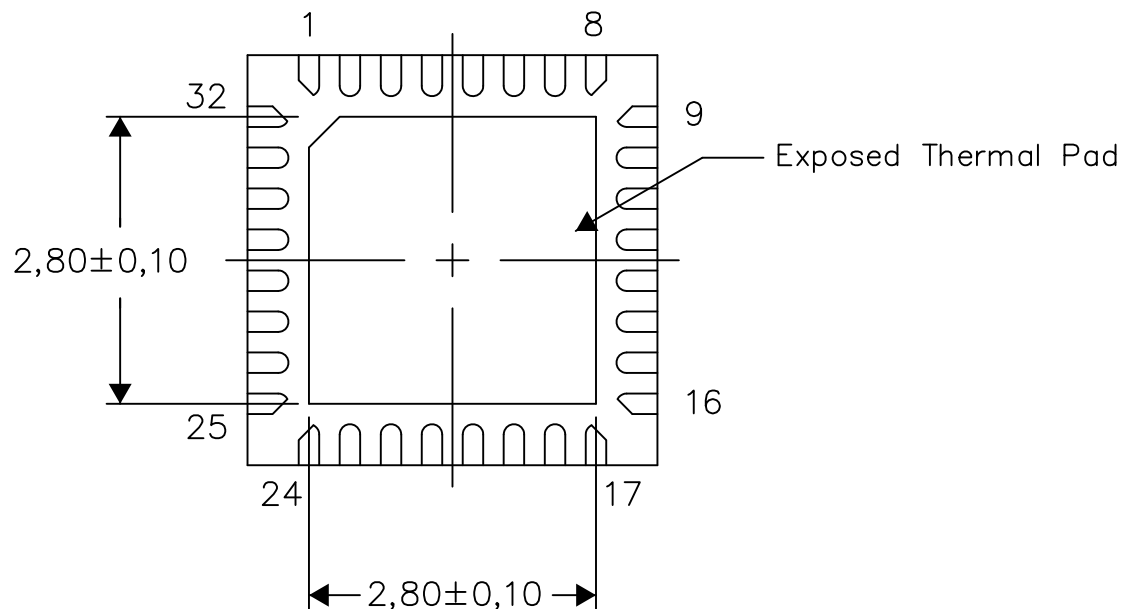

Bottom View

Exposed Thermal Pad Dimensions

4209775-2/F 03/14

NOTE: All linear dimensions are in millimeters

重要声明和免责声明

TI 提供技术和可靠性数据（包括数据表）、设计资源（包括参考设计）、应用或其他设计建议、网络工具、安全信息和其他资源，不保证没有瑕疵且不做任何明示或暗示的担保，包括但不限于对适销性、某特定用途方面的适用性或不侵犯任何第三方知识产权的暗示担保。

这些资源可供使用 TI 产品进行设计的熟练开发人员使用。您将自行承担以下全部责任：(1) 针对您的应用选择合适的 TI 产品，(2) 设计、验证并测试您的应用，(3) 确保您的应用满足相应标准以及任何其他安全、安保或其他要求。这些资源如有变更，恕不另行通知。TI 授权您仅可将这些资源用于研发本资源所述的 TI 产品的应用。严禁对这些资源进行其他复制或展示。您无权使用任何其他 TI 知识产权或任何第三方知识产权。您应全额赔偿因在这些资源的使用中对 TI 及其代表造成的任何索赔、损害、成本、损失和债务，TI 对此概不负责。

TI 提供的产品受 TI 的销售条款 (<https://www.ti.com.cn/zh-cn/legal/termsofsale.html>) 或 [ti.com.cn](https://www.ti.com.cn) 上其他适用条款/TI 产品随附的其他适用条款的约束。TI 提供这些资源并不会扩展或以其他方式更改 TI 针对 TI 产品发布的适用的担保或担保免责声明。

邮寄地址：上海市浦东新区世纪大道 1568 号中建大厦 32 楼，邮政编码：200122
Copyright © 2021 德州仪器半导体技术（上海）有限公司